

Plot file version 1 created 03-OCT-2017 13:27:09

J0927+3902 EG096C.UVDATA.1

Freq = 4.7990 GHz, Bw = 32.000 MH No calibration applied and no bandpass applied

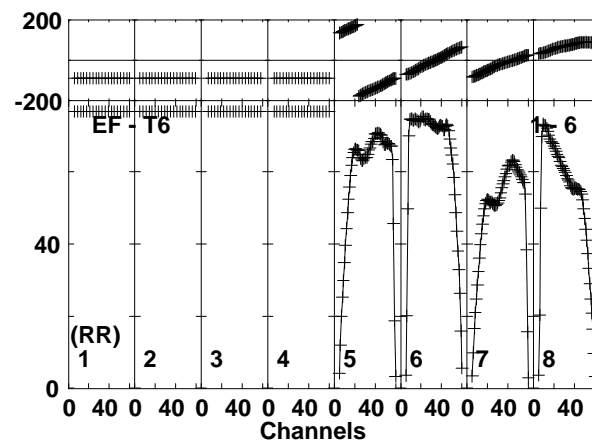
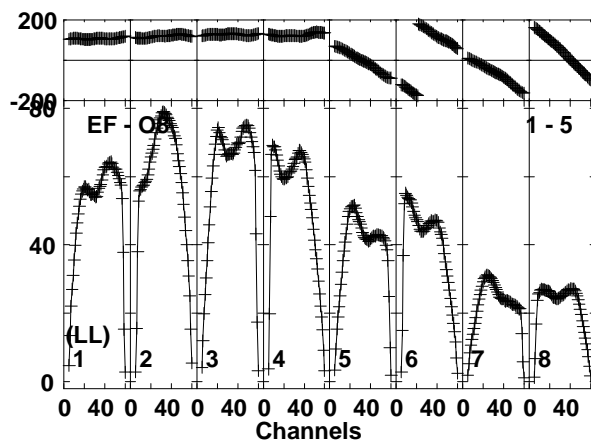
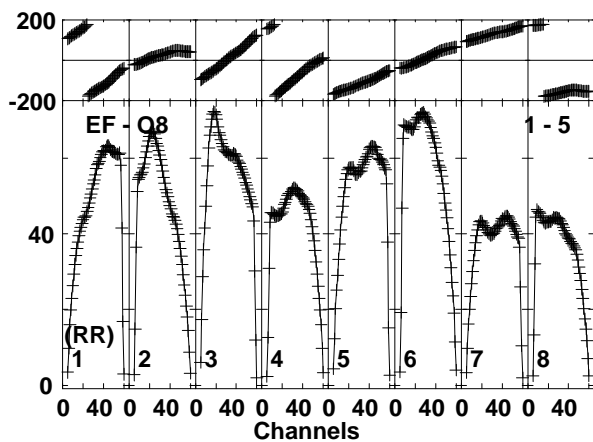
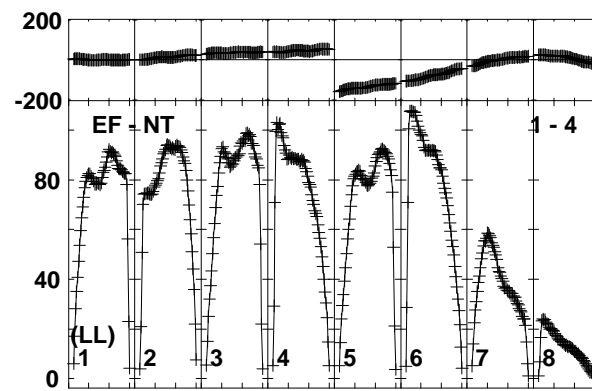
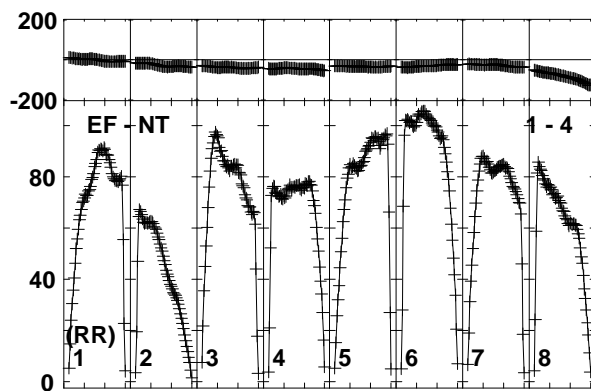
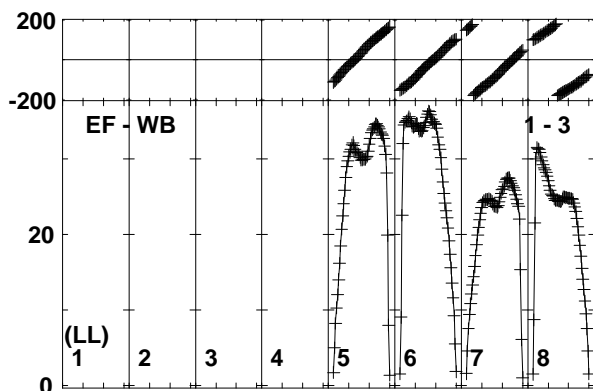
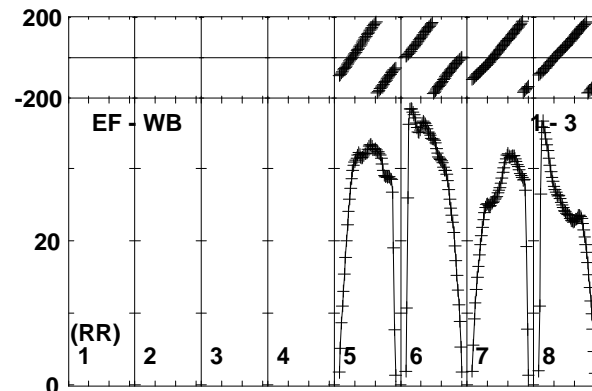
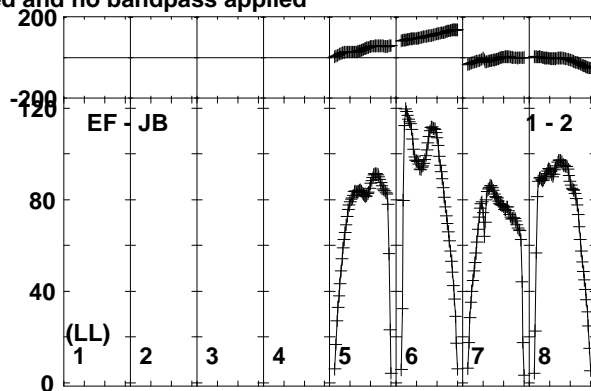
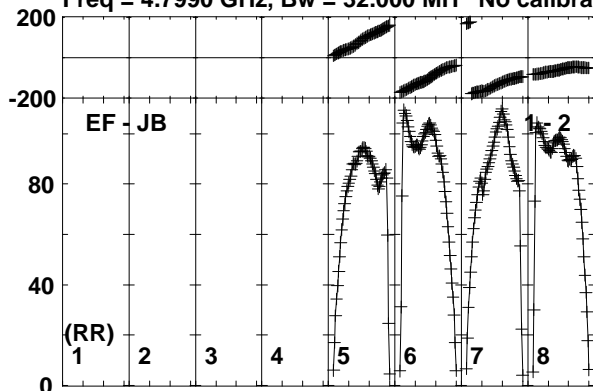

Lower frame: Milli Ampl Jy Top frame: Phas deg
Vector averaged cross-power spectrum Baseline: EF (01) - JB (02)
Timerange: 00/06:00:04 to 00/06:05:49

Plot file version 2 created 03-OCT-2017 13:27:09

J0927+3902 EG096C.UVDATA.1

Freq = 4.7990 GHz, Bw = 32.000 MH No calibration applied and no bandpass applied

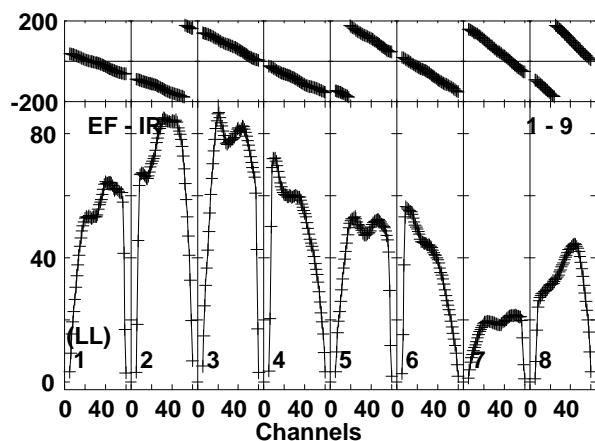
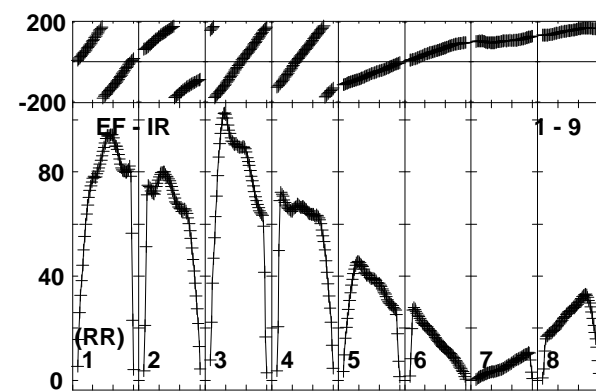
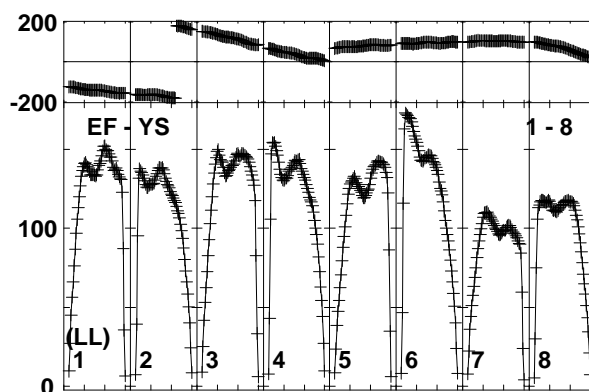
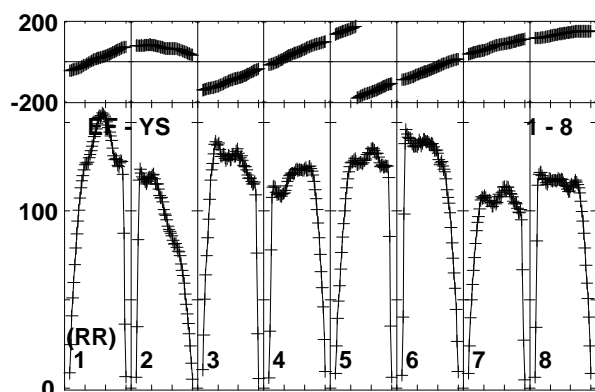
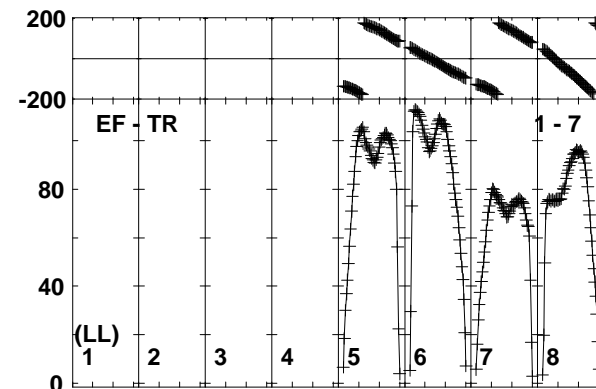
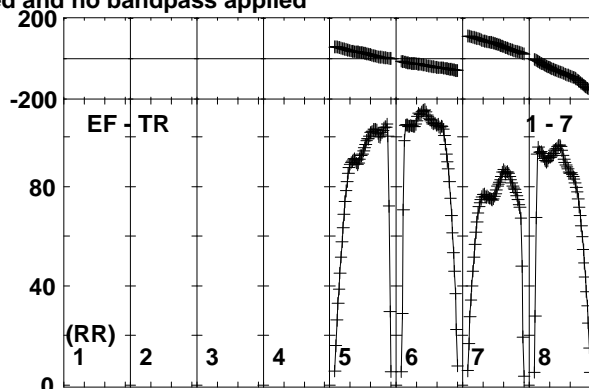
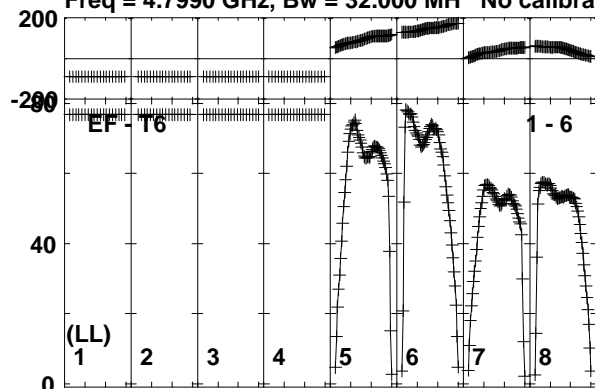

Lower frame: Milli Ampl Jy Top frame: Phas deg
Vector averaged cross-power spectrum Baseline: EF (01) - T6 (06)
Timerange: 00/06:00:04 to 00/06:05:49

Plot file version 3 created 03-OCT-2017 13:27:10

J1108+4330 EG096C.UVDATA.1

Freq = 4.7990 GHz, Bw = 32.000 MH No calibration applied and no bandpass applied

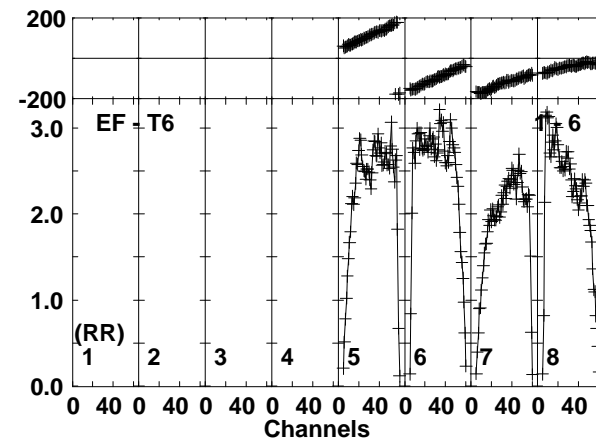
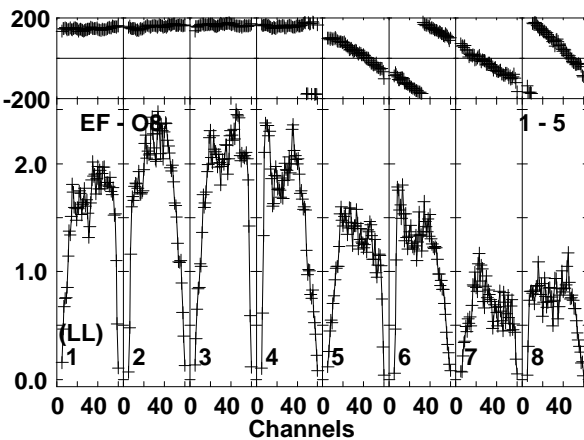
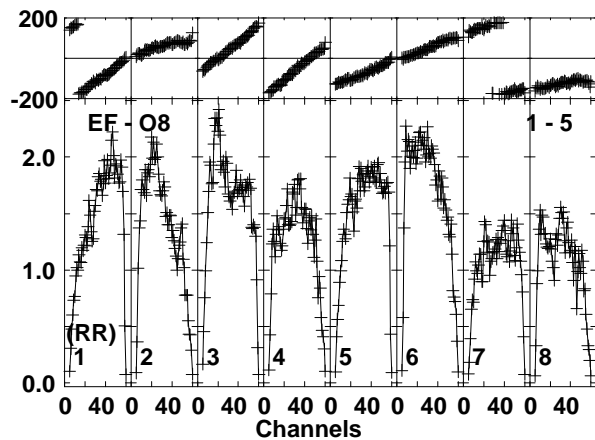
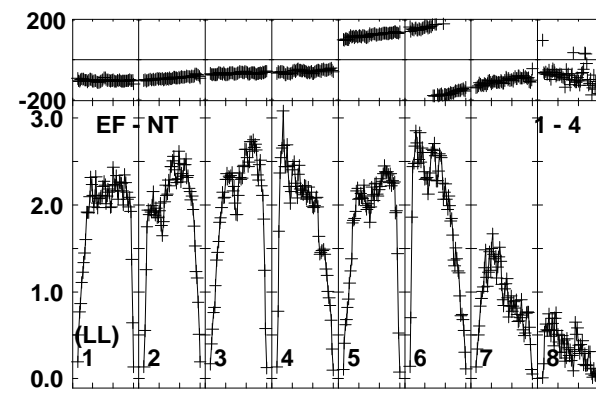
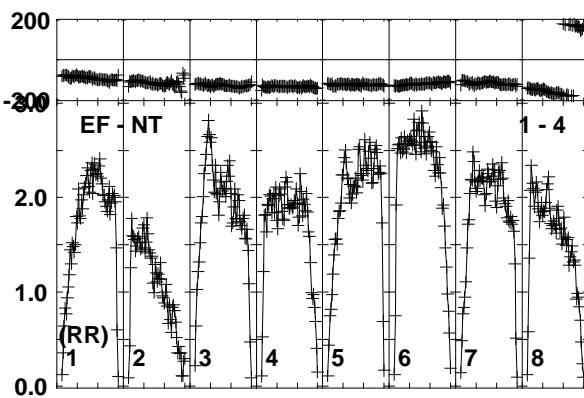
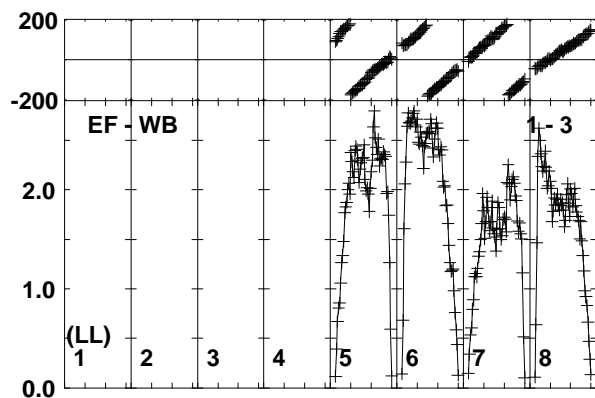
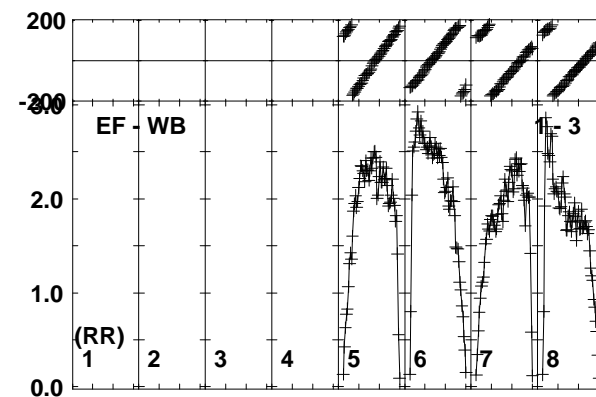
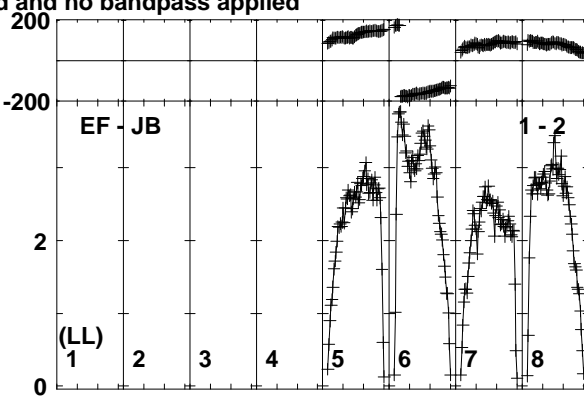
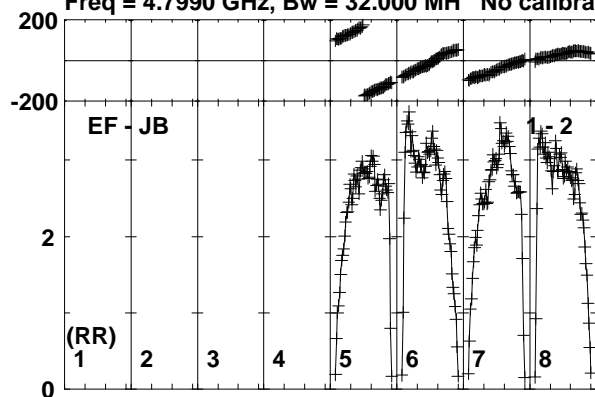

Lower frame: Milli Ampl Jy Top frame: Phas deg
Vector averaged cross-power spectrum Baseline: EF (01) - JB (02)
Timerange: 00/06:07:50 to 00/06:08:48

Plot file version 4 created 03-OCT-2017 13:27:10

J1108+4330 EG096C.UVDATA.1

Freq = 4.7990 GHz, Bw = 32.000 MH No calibration applied and no bandpass applied

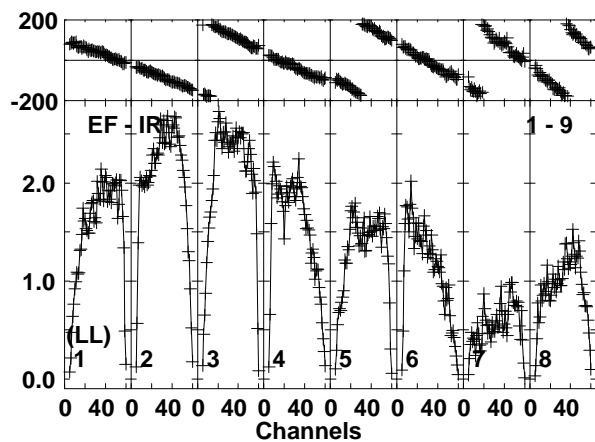
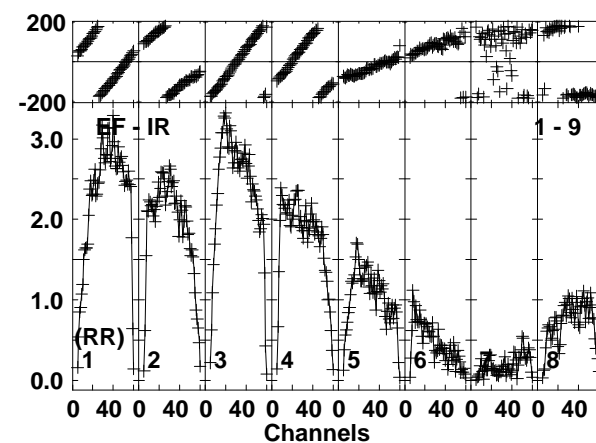
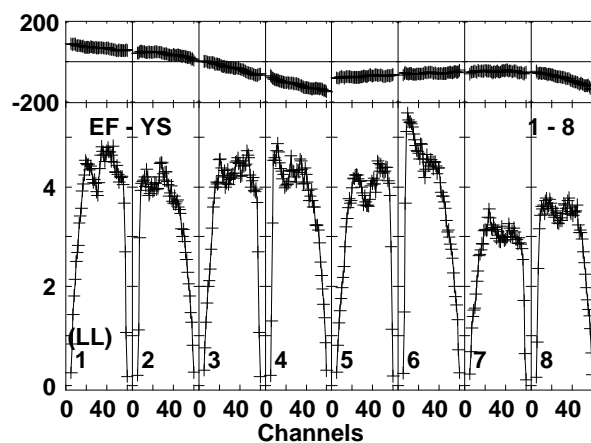
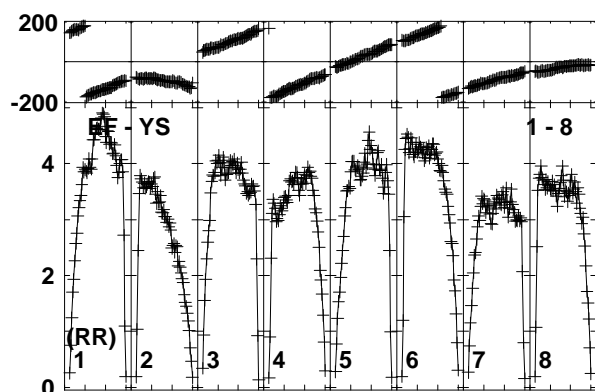
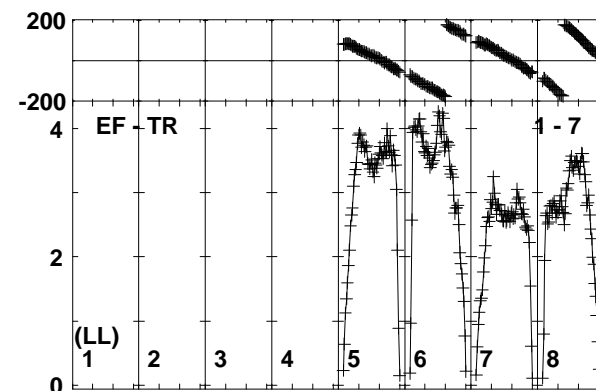
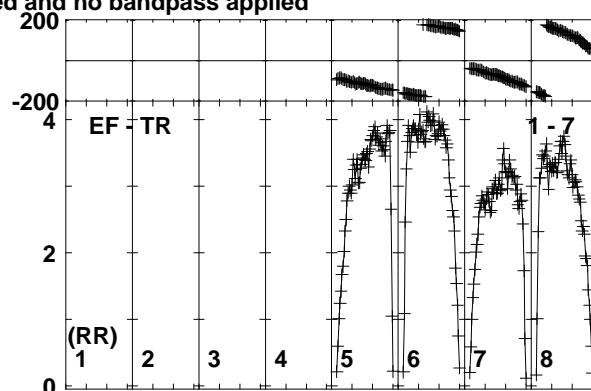
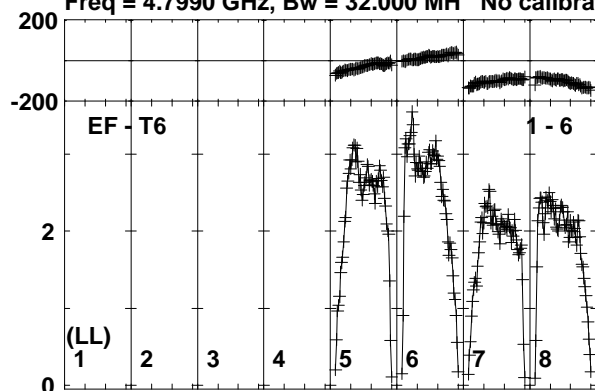

Lower frame: Milli Ampl Jy Top frame: Phas deg
Vector averaged cross-power spectrum Baseline: EF (01) - T6 (06)
Timerange: 00/06:07:50 to 00/06:08:48

Plot file version 5 created 03-OCT-2017 13:27:10

J1108+4330 EG096C.UVDATA.1

Freq = 4.7990 GHz, Bw = 32.000 MH No calibration applied and no bandpass applied

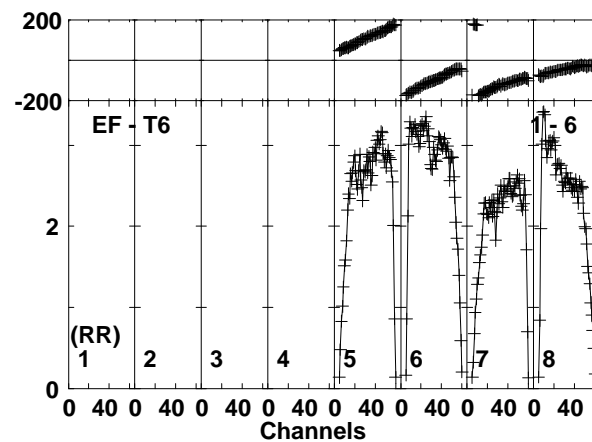
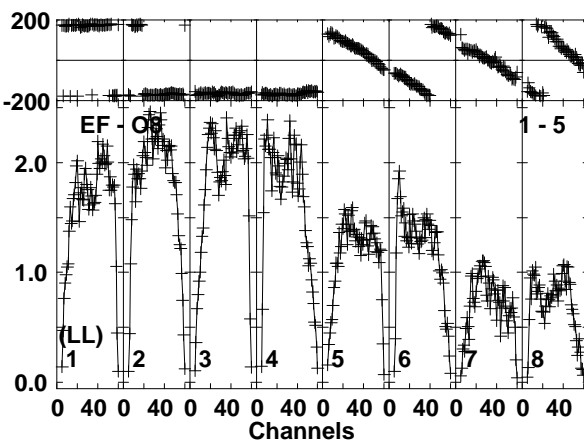
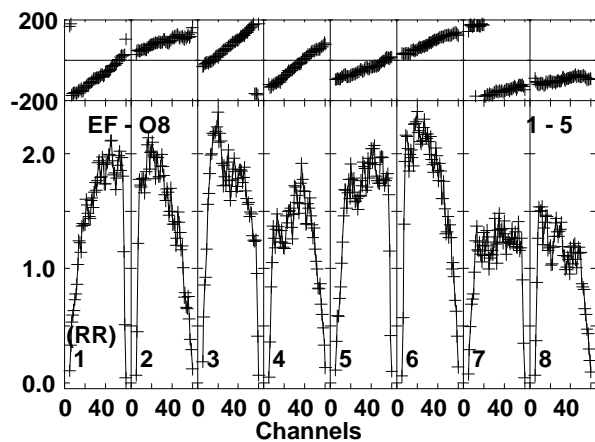
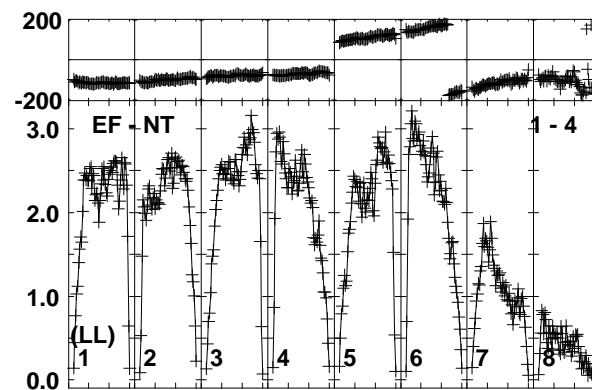
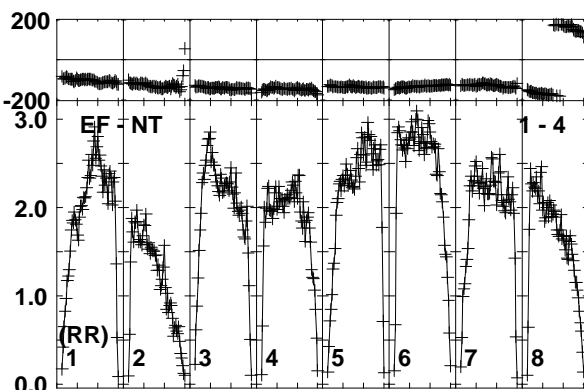
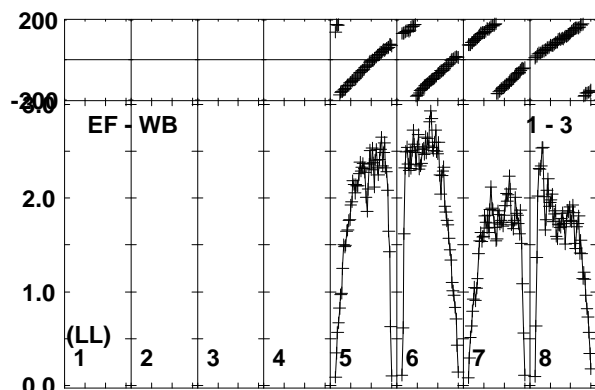
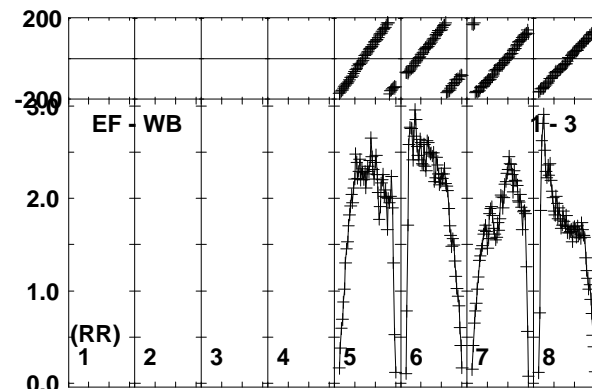
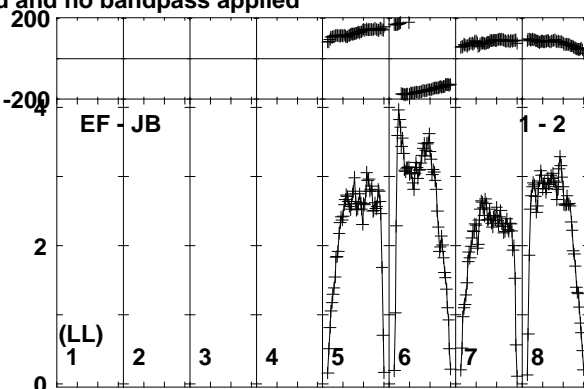
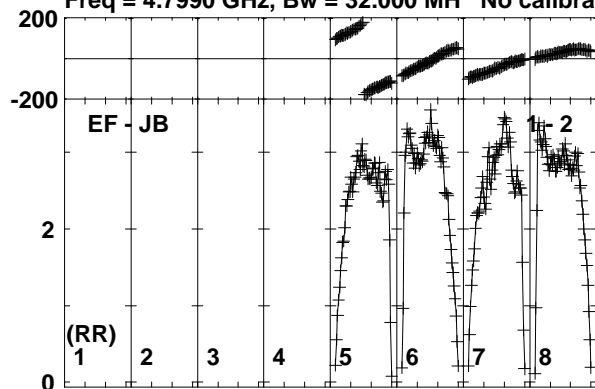

Lower frame: Milli Ampl Jy Top frame: Phas deg
Vector averaged cross-power spectrum Baseline: EF (01) - JB (02)
Timerange: 00/06:09:30 to 00/06:10:28

Plot file version 6 created 03-OCT-2017 13:27:10
 J1108+4330 EG096C.UVDATA.1

Freq = 4.7990 GHz, Bw = 32.000 MH No calibration applied and no bandpass applied

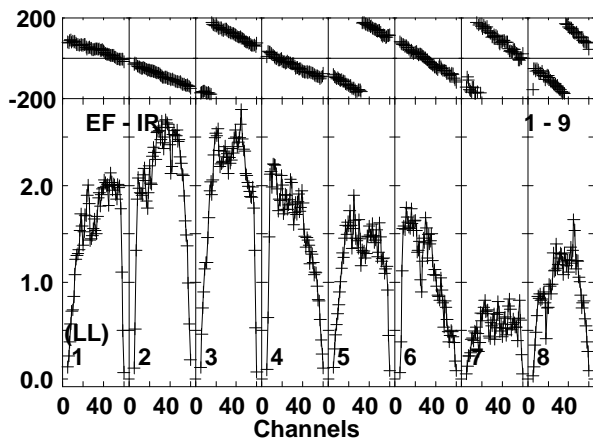
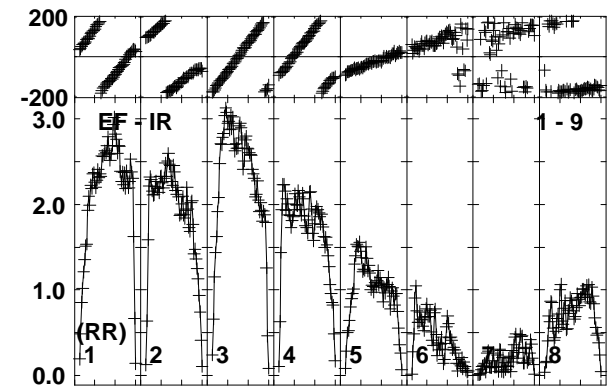
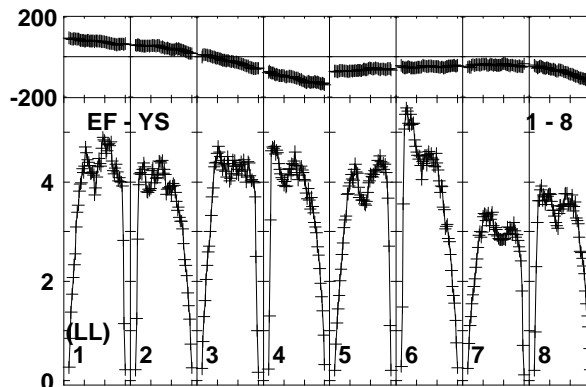
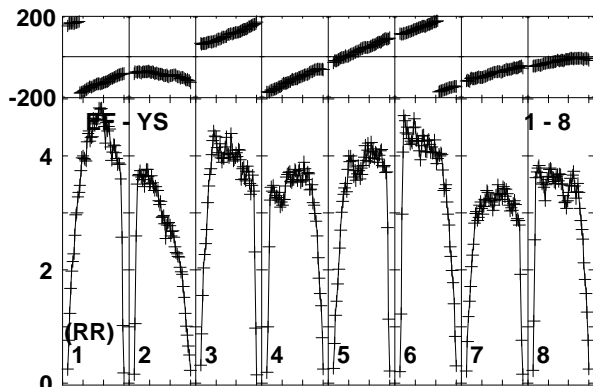
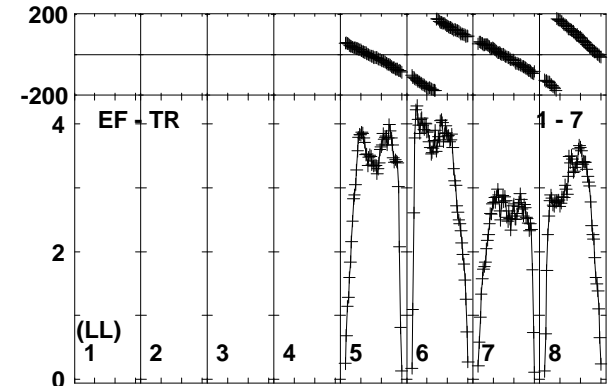
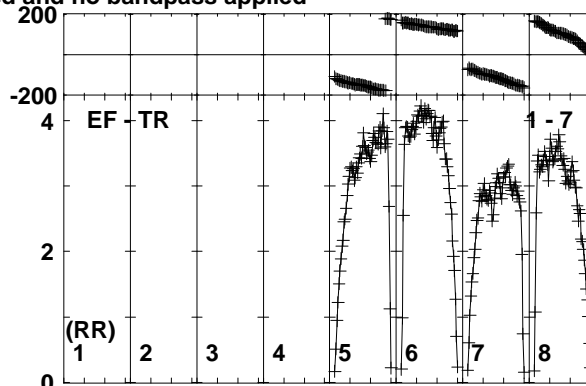
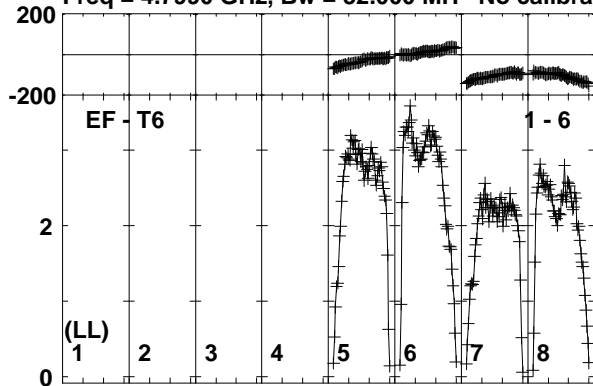

Lower frame: Milli Ampl Jy Top frame: Phas deg
 Vector averaged cross-power spectrum Baseline: EF (01) - T6 (06)
 Timerange: 00/06:09:30 to 00/06:10:28

Plot file version 7 created 03-OCT-2017 13:27:10

J1112+4301 EG096C.UVDATA.1

Freq = 4.7990 GHz, Bw = 32.000 MH No calibration applied and no bandpass applied

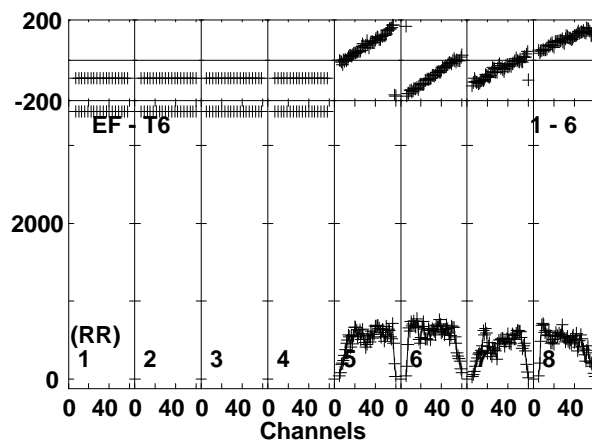
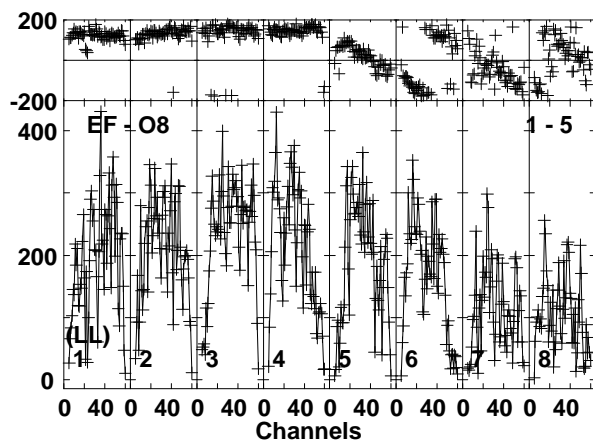
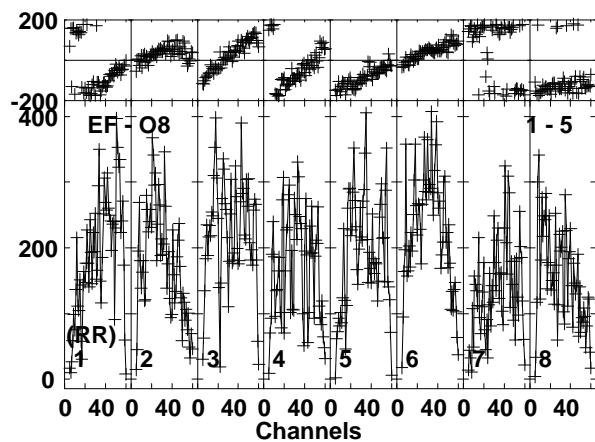
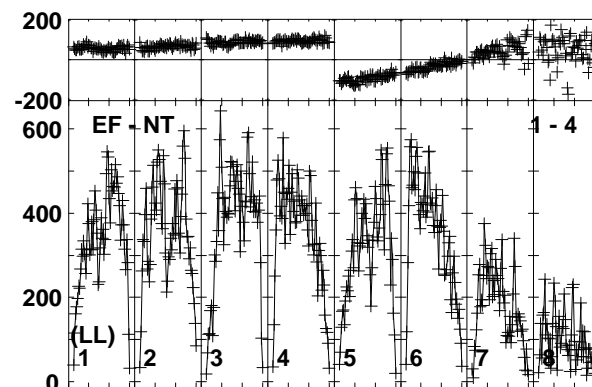
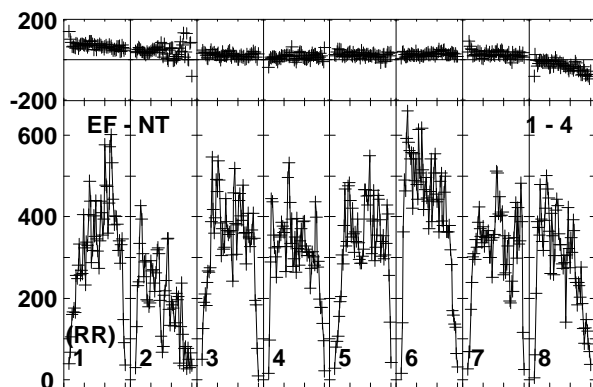
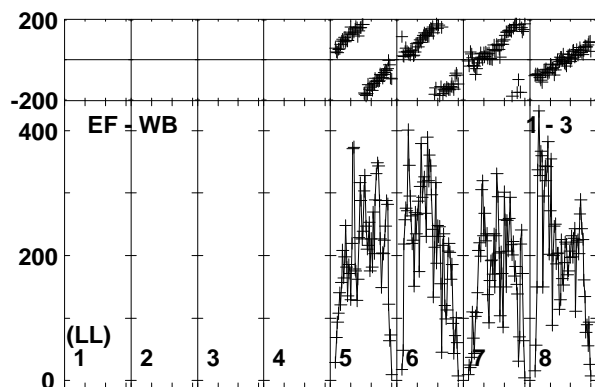
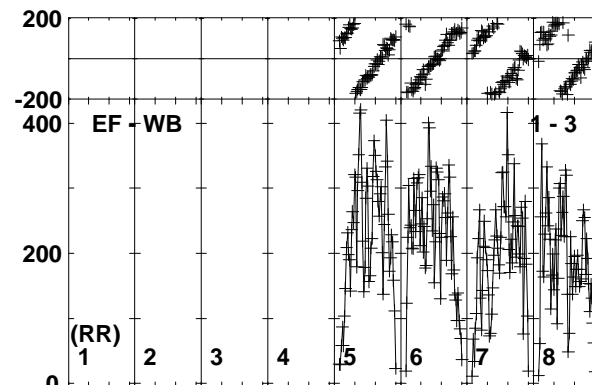
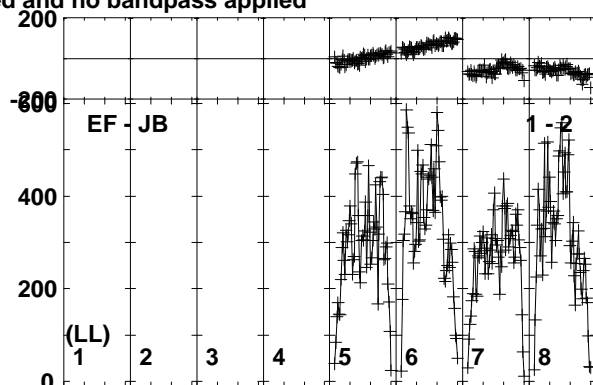
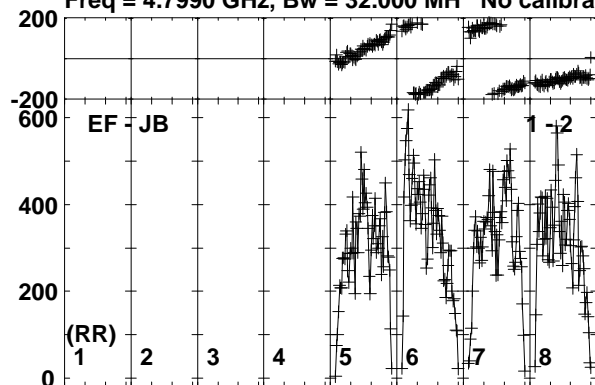

Lower frame: Micro Ampl Jy Top frame: Phas deg
Vector averaged cross-power spectrum Baseline: EF (01) - JB (02)
Timerange: 00/06:10:30 to 00/06:13:59

Plot file version 8 created 03-OCT-2017 13:27:10

J1112+4301 EG096C.UVDATA.1

Freq = 4.7990 GHz, Bw = 32.000 MH No calibration applied and no bandpass applied

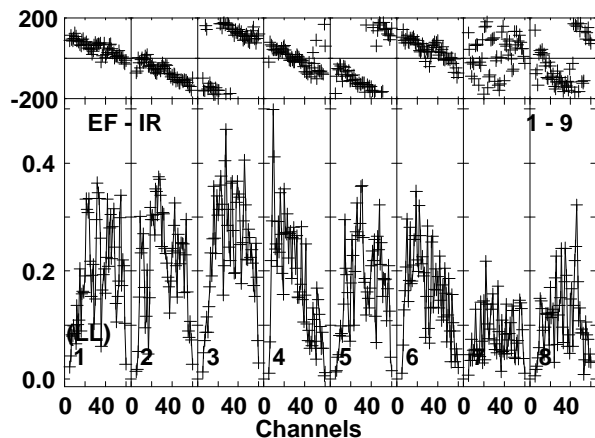
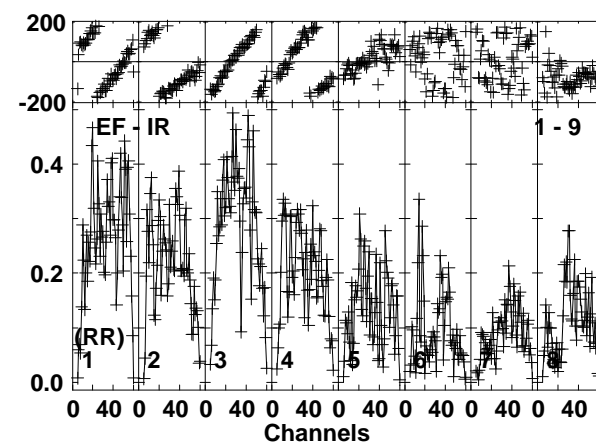
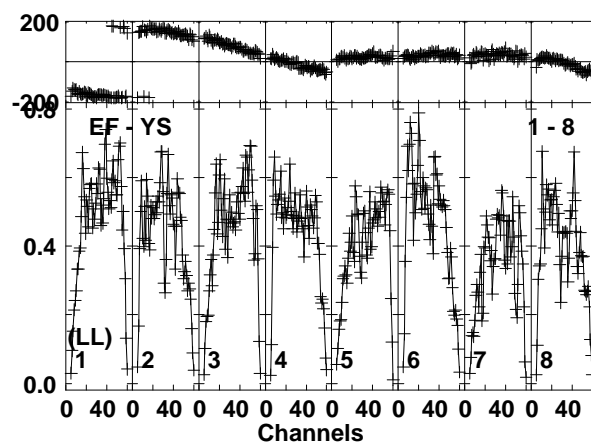
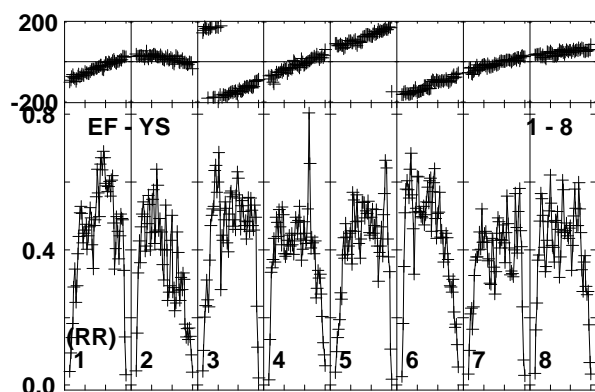
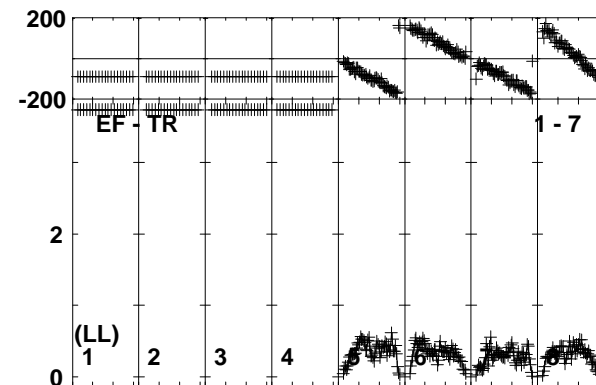
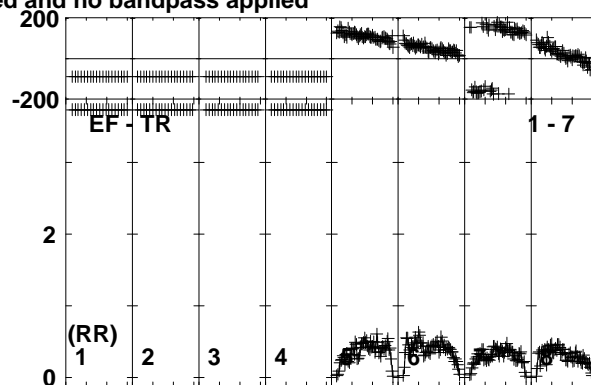
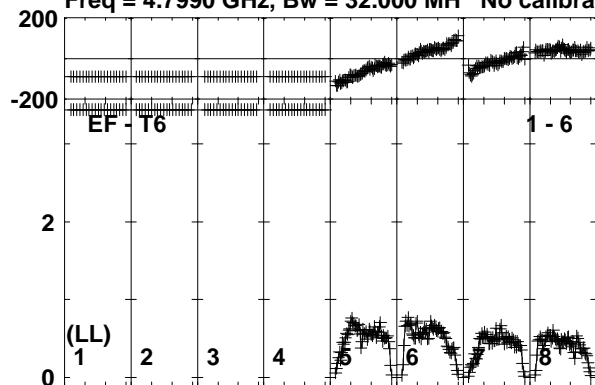

Lower frame: Milli Ampl Jy Top frame: Phas deg
Vector averaged cross-power spectrum Baseline: EF (01) - T6 (06)
Timerange: 00/06:10:30 to 00/06:13:59

Plot file version 9 created 03-OCT-2017 13:27:11

J1108+4330 EG096C.UVDATA.1

Freq = 4.7990 GHz, Bw = 32.000 MH No calibration applied and no bandpass applied

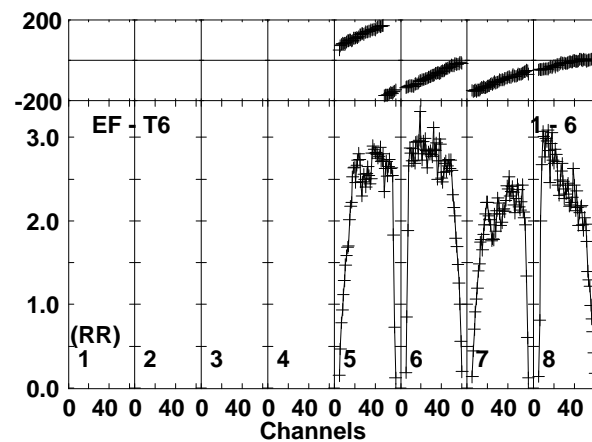
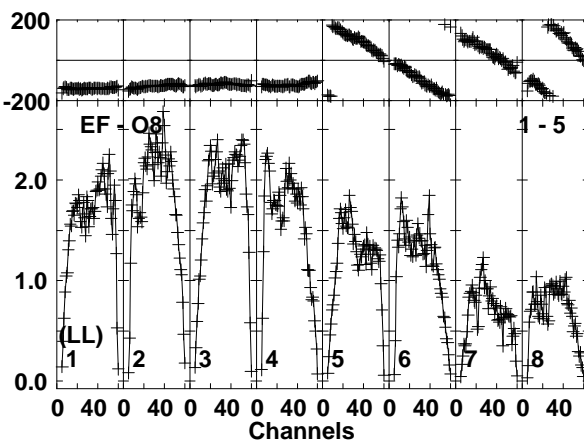
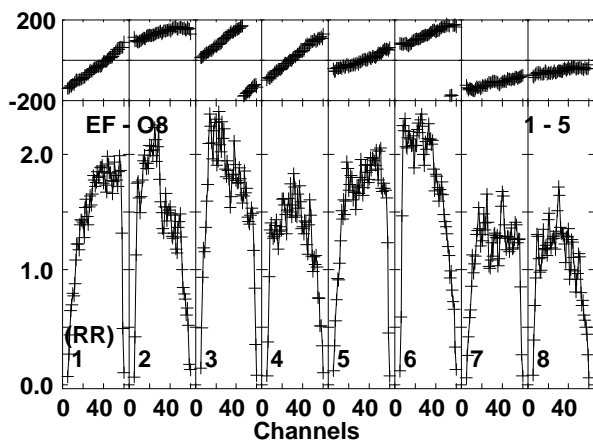
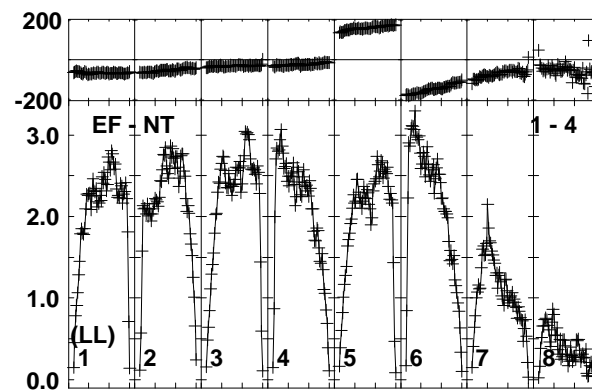
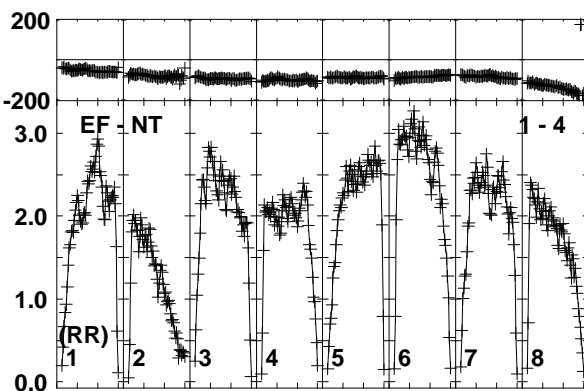
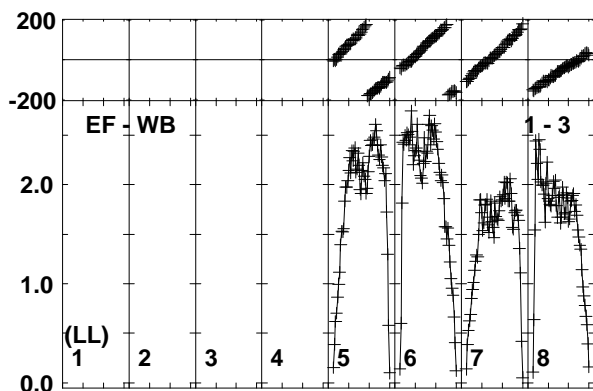
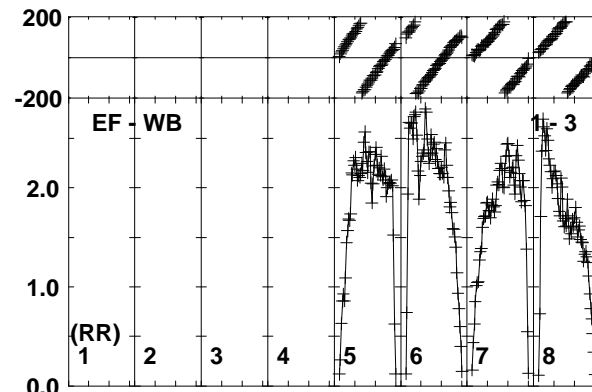
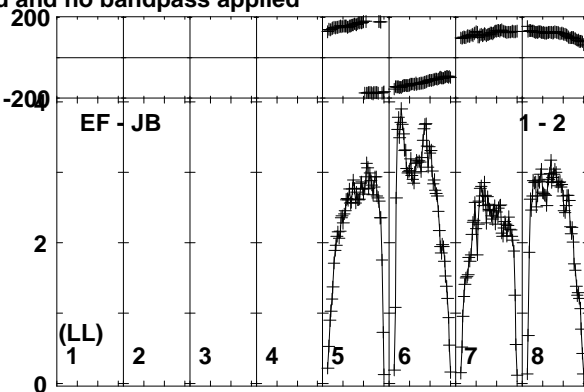
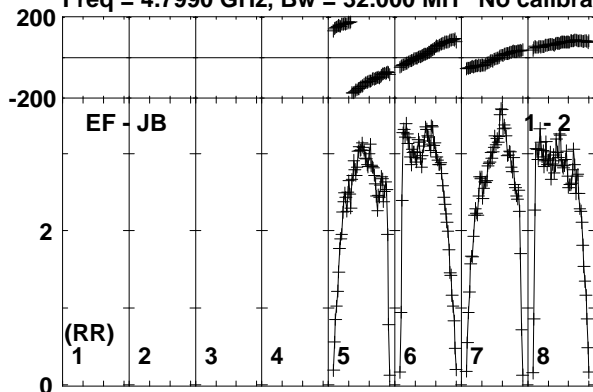

Lower frame: Milli Ampl Jy Top frame: Phas deg
Vector averaged cross-power spectrum Baseline: EF (01) - JB (02)
Timerange: 00/06:14:00 to 00/06:15:29

Plot file version 10 created 03-OCT-2017 13:27:11

J1108+4330 EG096C.UVDATA.1

Freq = 4.7990 GHz, Bw = 32.000 MH No calibration applied and no bandpass applied

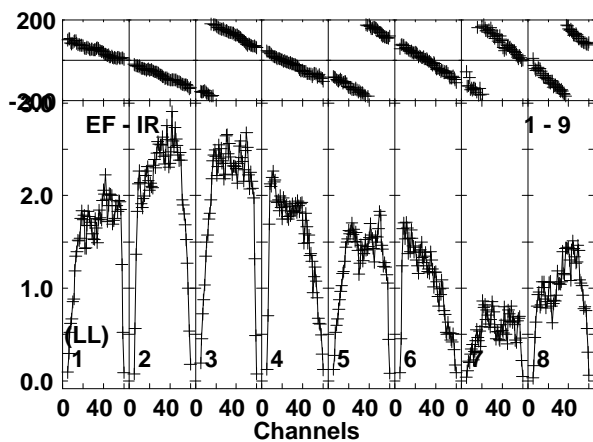
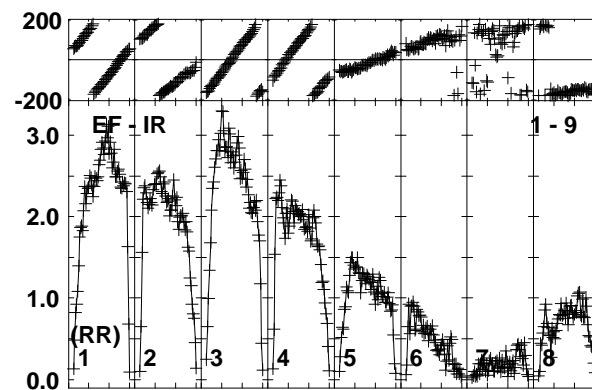
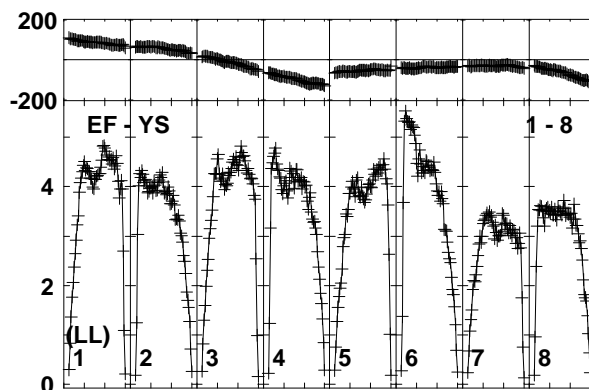
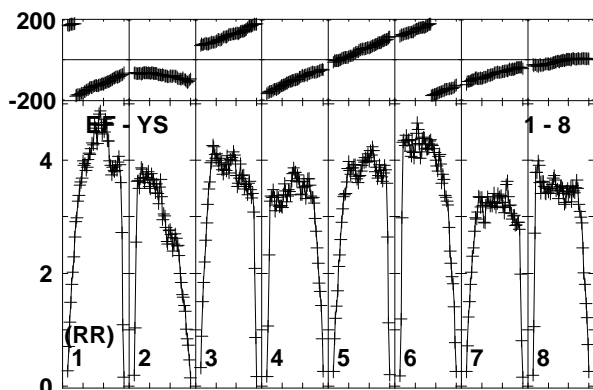
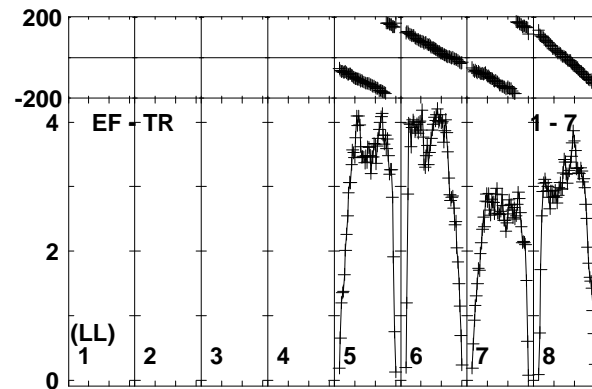
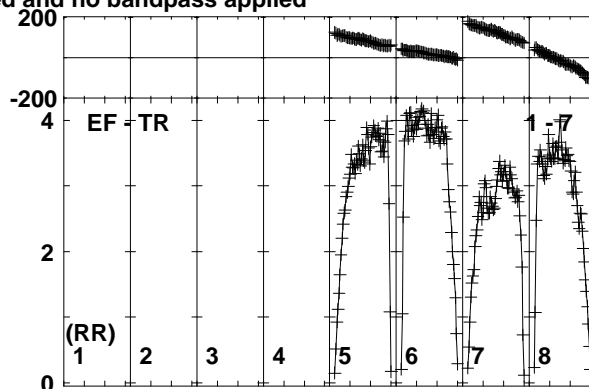
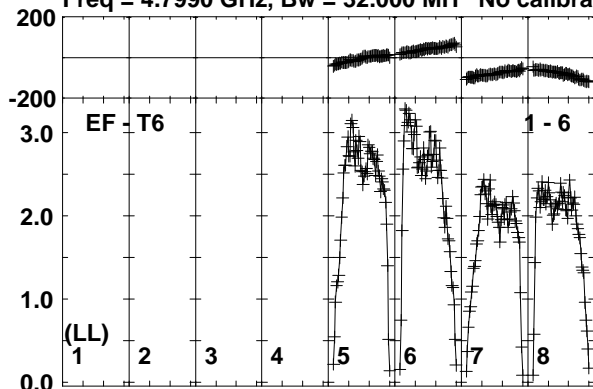

Lower frame: Milli Ampl Jy Top frame: Phas deg
Vector averaged cross-power spectrum Baseline: EF (01) - T6 (06)
Timerange: 00/06:14:00 to 00/06:15:29

Plot file version 11 created 03-OCT-2017 13:27:11

ARUMA EG096C.UVDATA.1

Freq = 4.7990 GHz, Bw = 32.000 MH No calibration applied and no bandpass applied

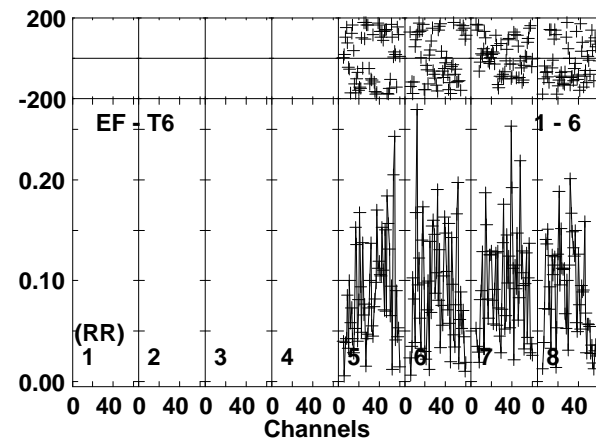
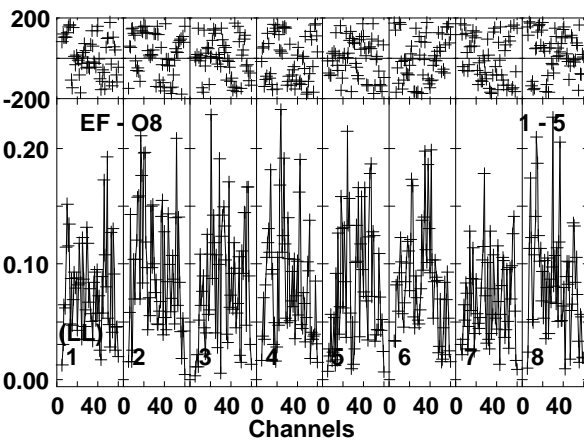
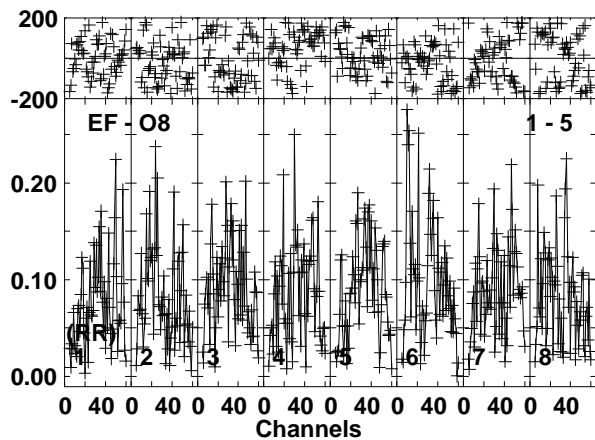
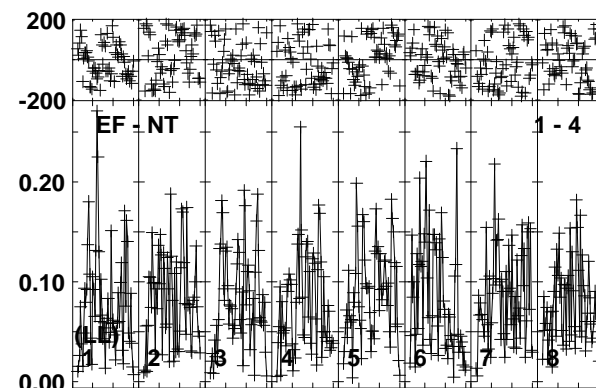
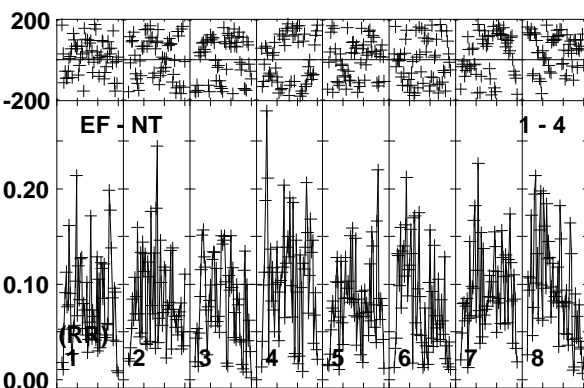
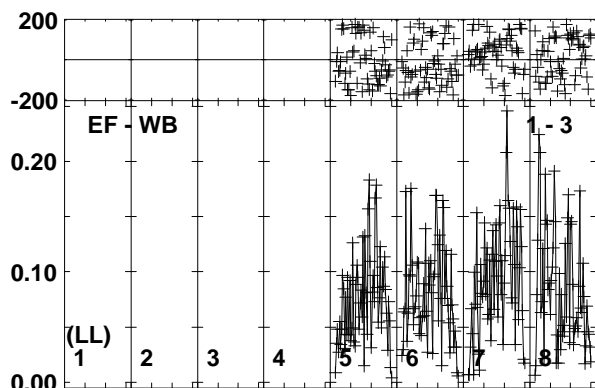
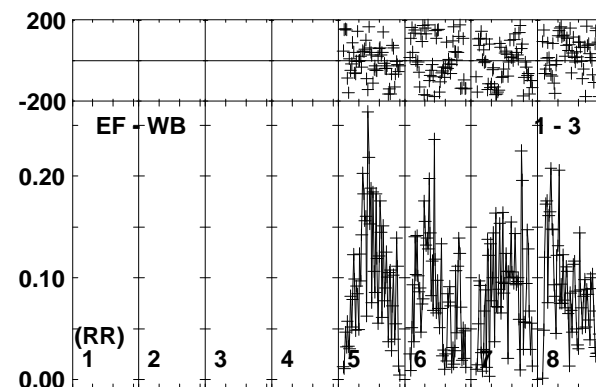
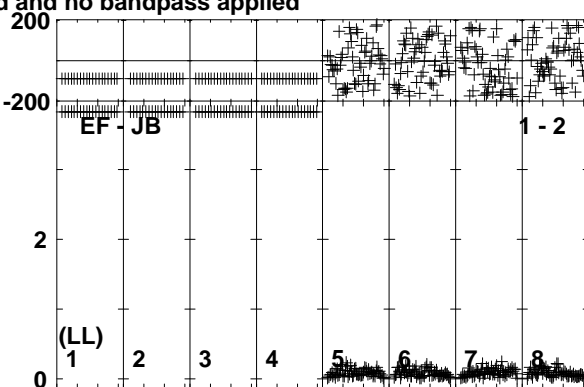
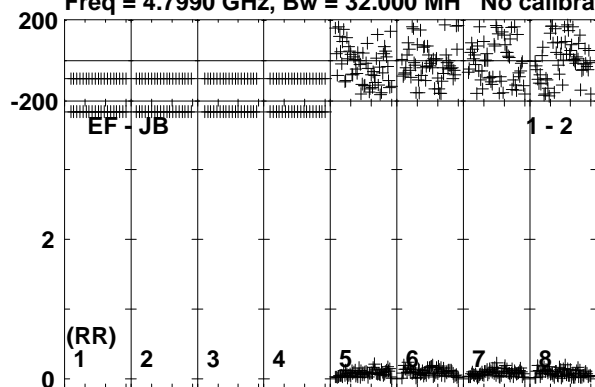

Lower frame: Milli Ampl Jy Top frame: Phas deg
Vector averaged cross-power spectrum Baseline: EF (01) - JB (02)
Timerange: 00/06:15:30 to 00/06:18:59

Plot file version 12 created 03-OCT-2017 13:27:11

ARUMA EG096C.UVDATA.1

Freq = 4.7990 GHz, Bw = 32.000 MH No calibration applied and no bandpass applied

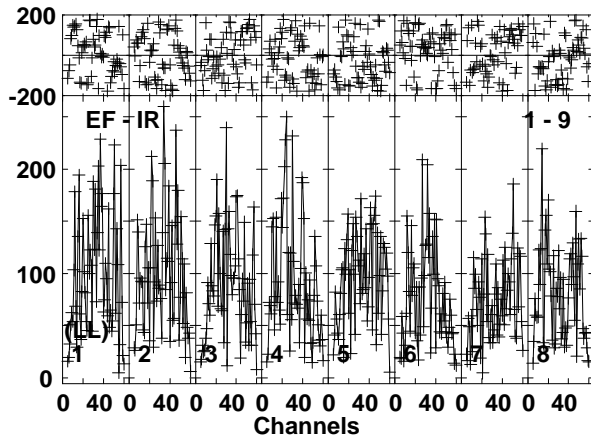
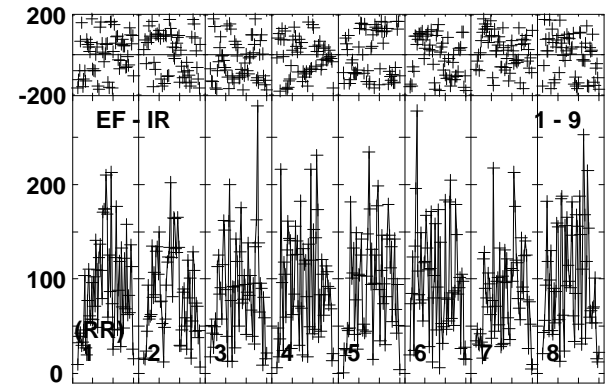
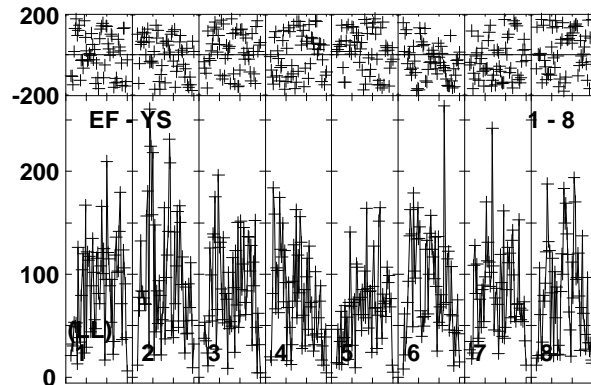
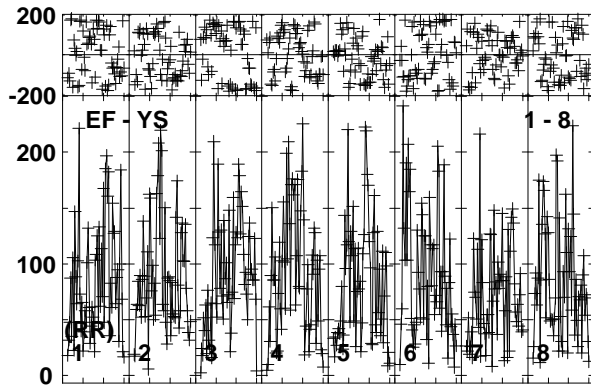
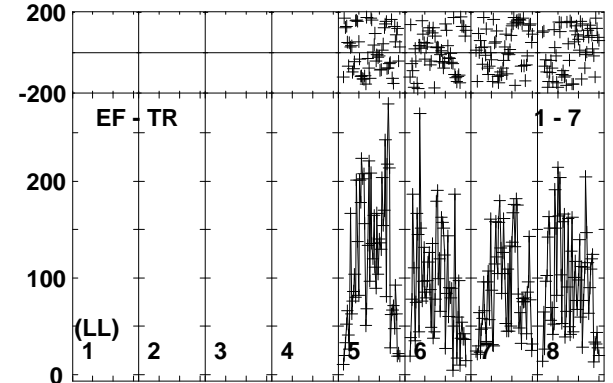
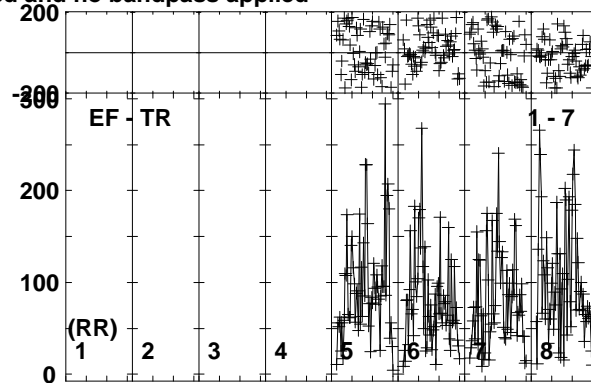
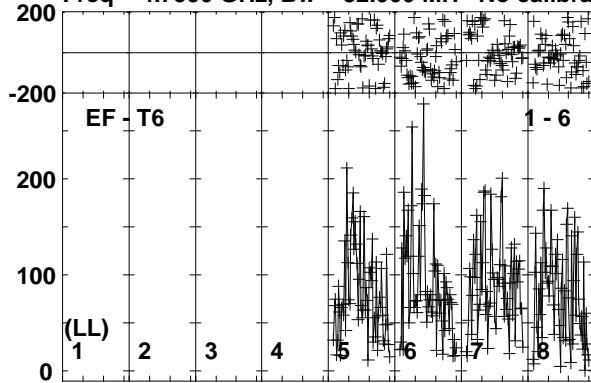

Lower frame: Micro Ampl Jy Top frame: Phas deg
Vector averaged cross-power spectrum Baseline: EF (01) - T6 (06)
Timerange: 00/06:15:30 to 00/06:18:59

Plot file version 13 created 03-OCT-2017 13:27:11

J1108+4330 EG096C.UVDATA.1

Freq = 4.7990 GHz, Bw = 32.000 MH No calibration applied and no bandpass applied

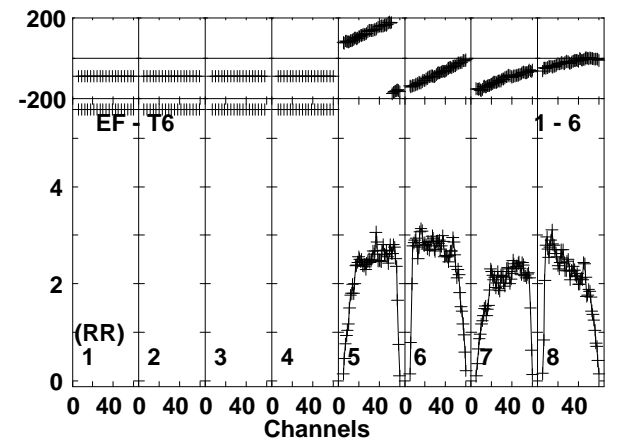
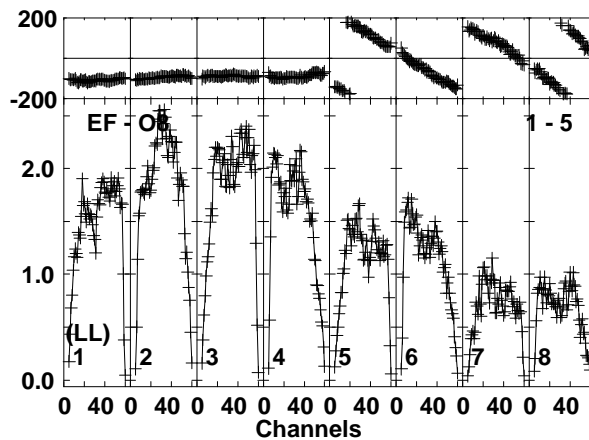
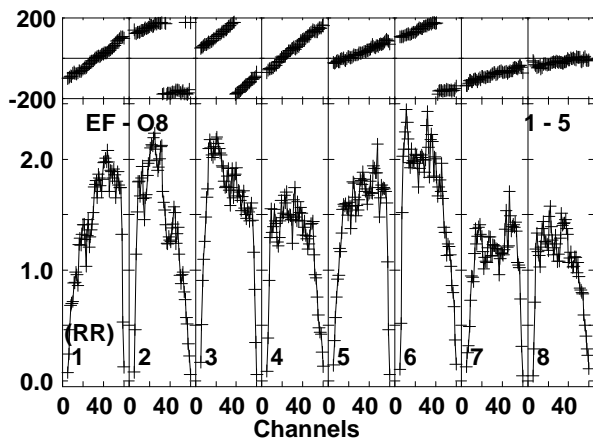
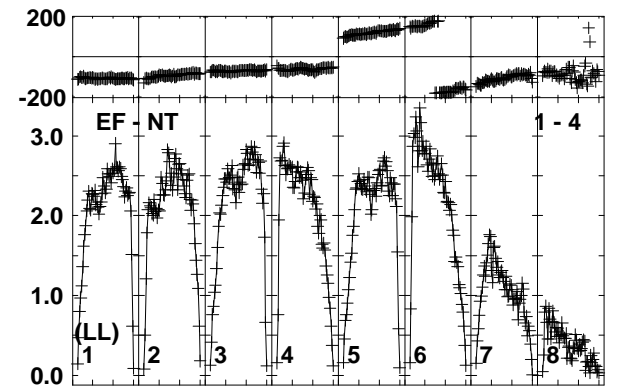
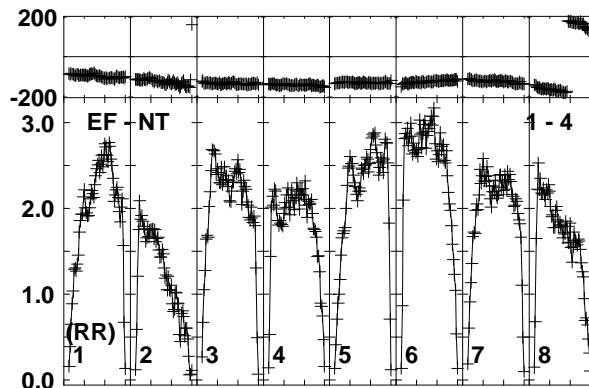
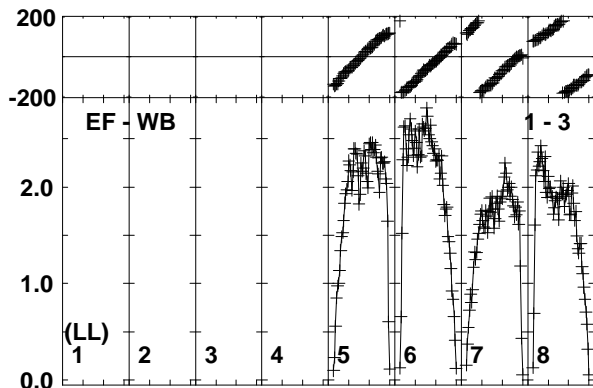
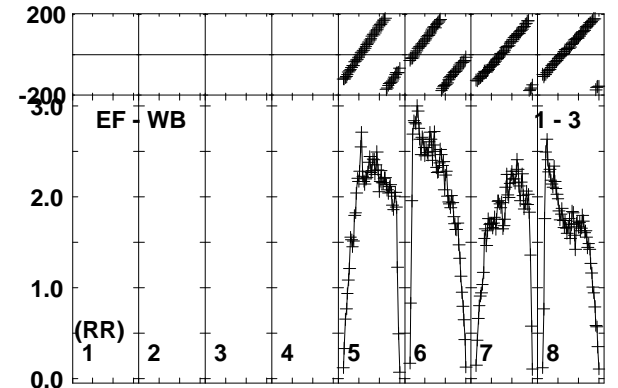
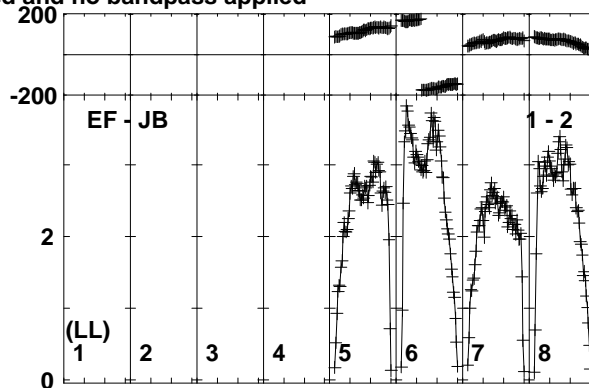
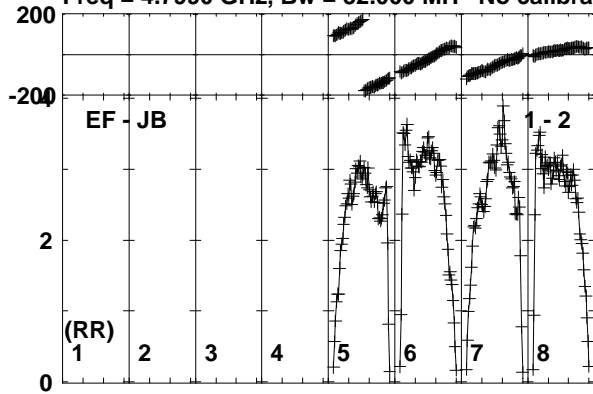

Lower frame: Milli Ampl Jy Top frame: Phas deg
Vector averaged cross-power spectrum Baseline: EF (01) - JB (02)
Timerange: 00/06:19:39 to 00/06:20:39

Plot file version 14 created 03-OCT-2017 13:27:12

J1108+4330 EG096C.UVDATA.1

Freq = 4.7990 GHz, Bw = 32.000 MH No calibration applied and no bandpass applied

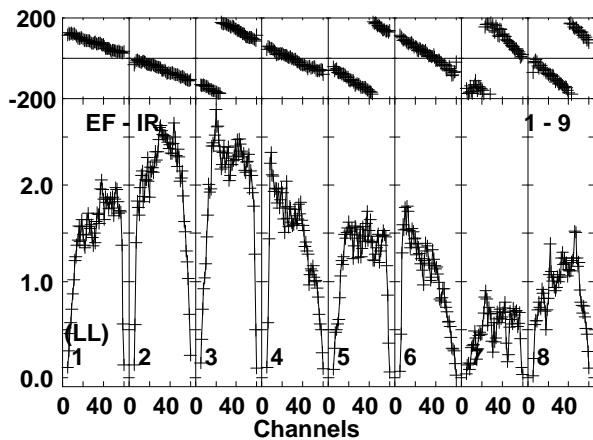
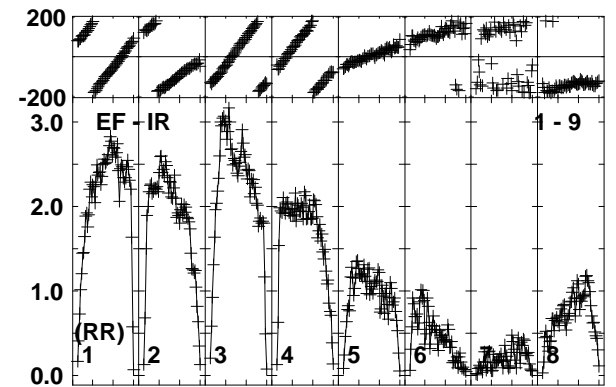
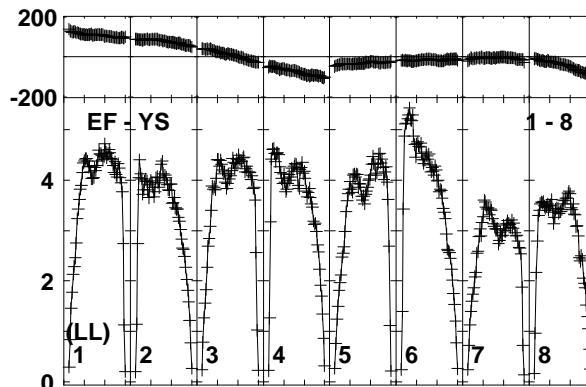
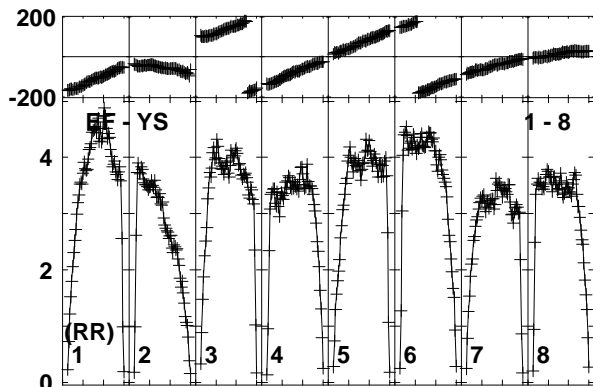
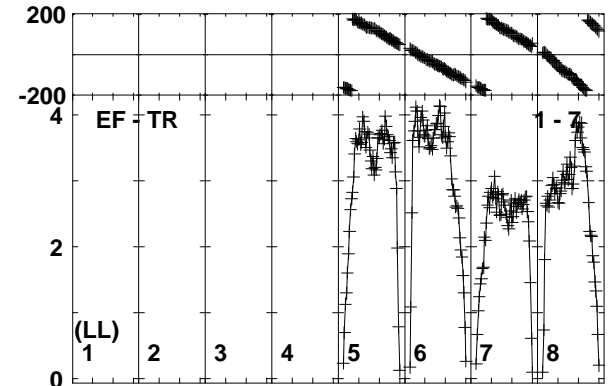
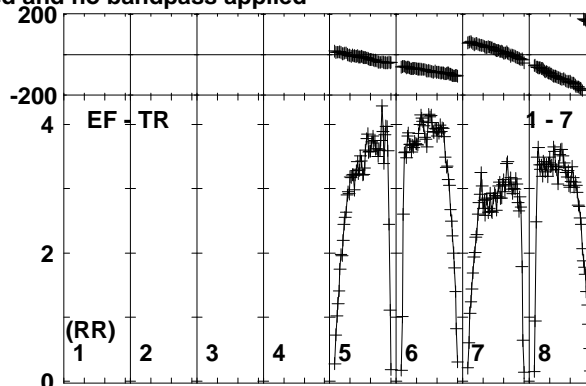
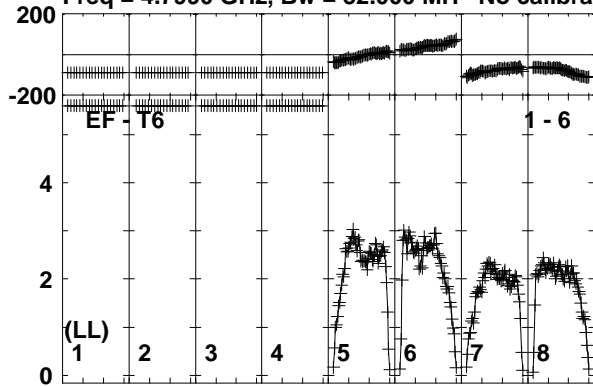

Lower frame: Milli Ampl Jy Top frame: Phas deg
Vector averaged cross-power spectrum Baseline: EF (01) - T6 (06)
Timerange: 00/06:19:39 to 00/06:20:39

Plot file version 15 created 03-OCT-2017 13:27:12

ARUMA EG096C.UVDATA.1

Freq = 4.7990 GHz, Bw = 32.000 MH No calibration applied and no bandpass applied

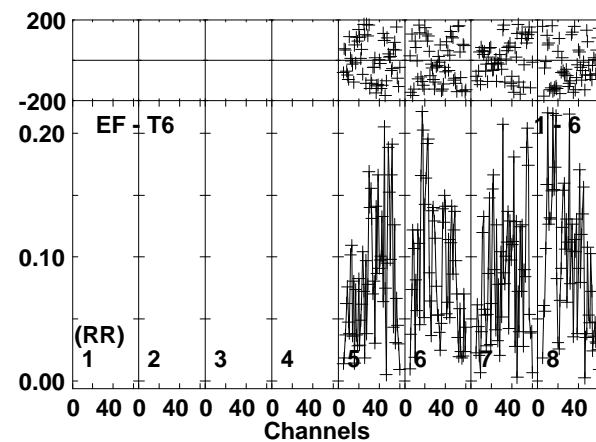
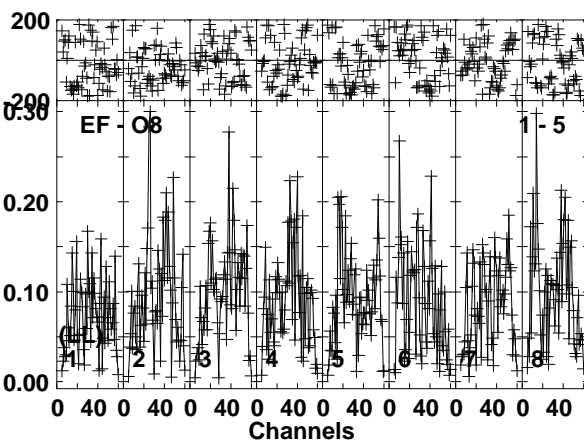
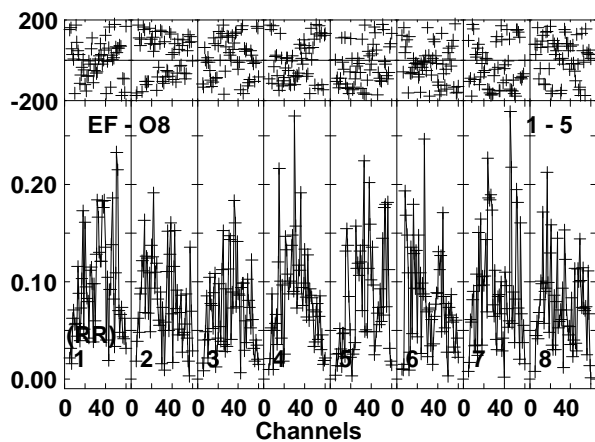
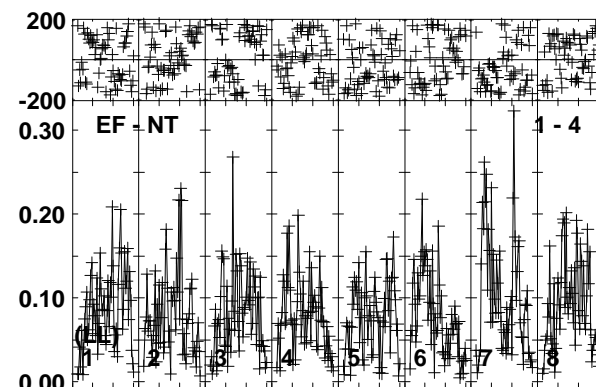
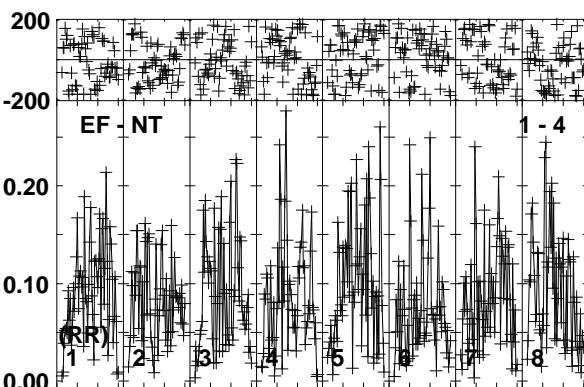
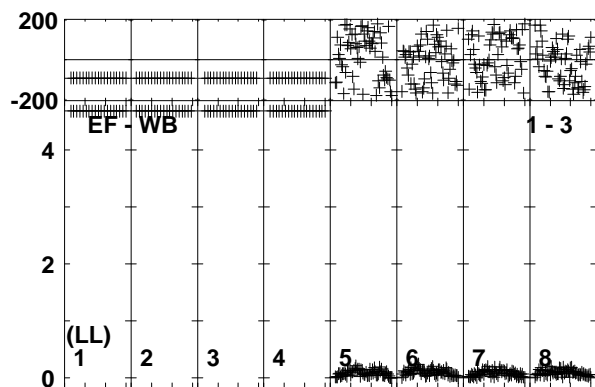
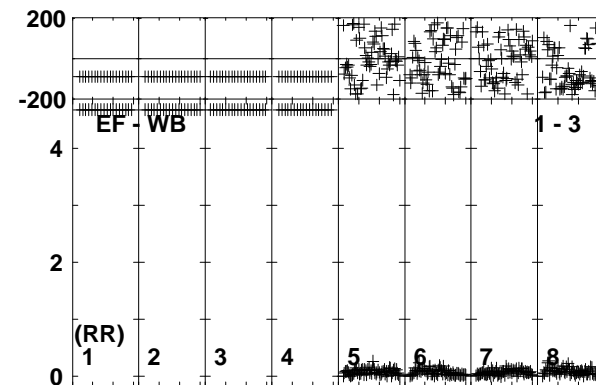
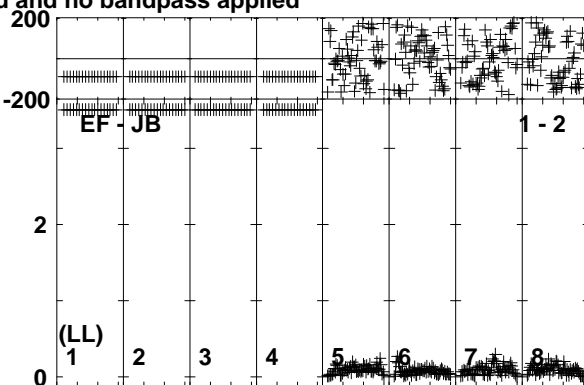
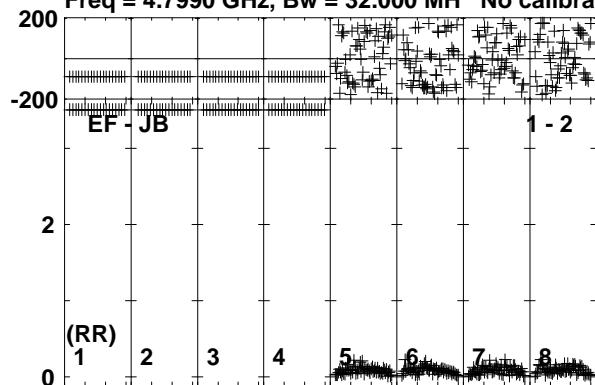

Lower frame: Milli Ampl Jy Top frame: Phas deg
Vector averaged cross-power spectrum Baseline: EF (01) - JB (02)
Timerange: 00/06:20:39 to 00/06:24:09

Plot file version 16 created 03-OCT-2017 13:27:12

ARUMA EG096C.UVDATA.1

Freq = 4.7990 GHz, Bw = 32.000 MH No calibration applied and no bandpass applied

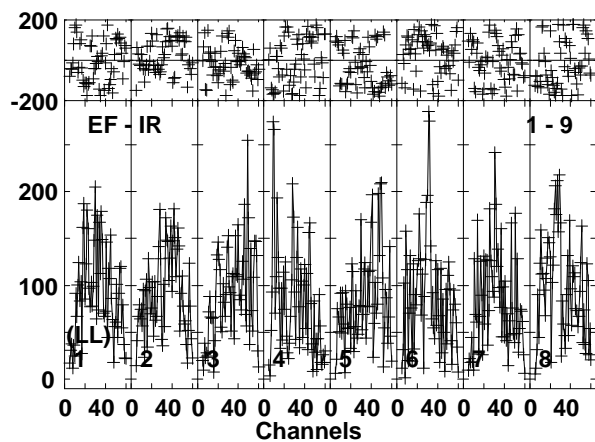
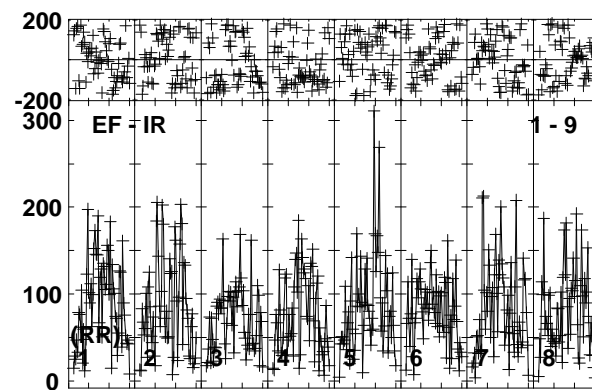
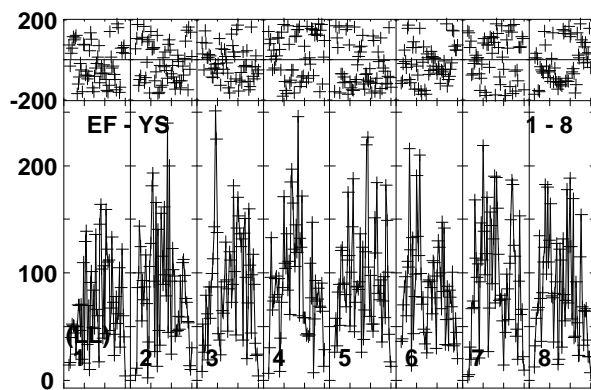
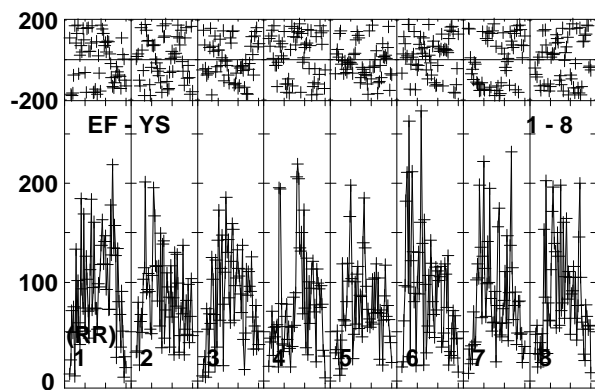
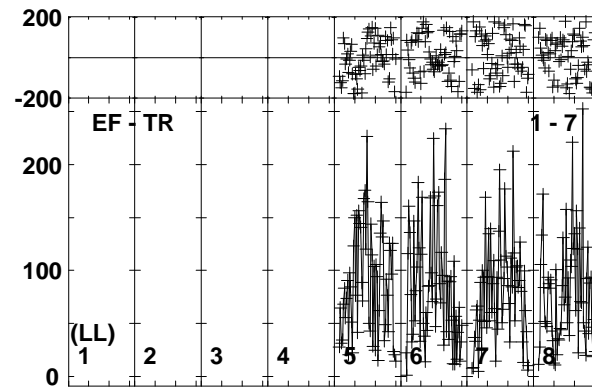
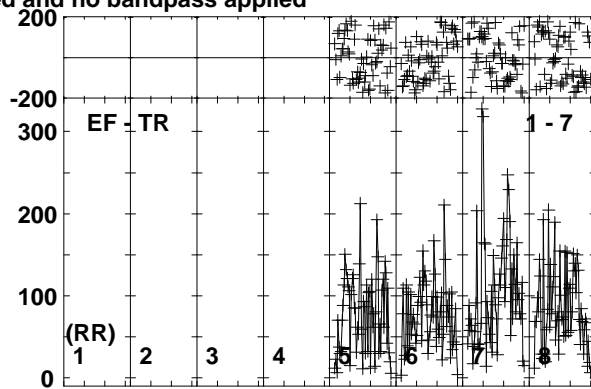
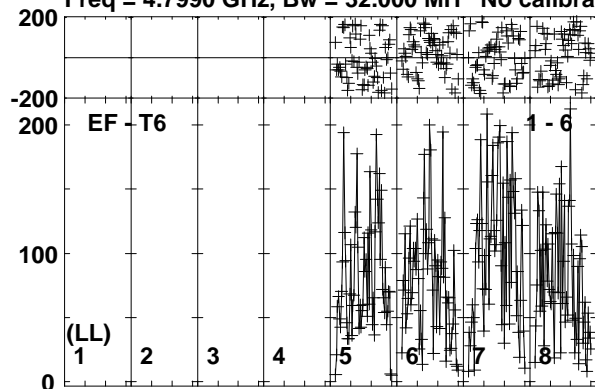

Lower frame: Micro Ampl Jy Top frame: Phas deg
Vector averaged cross-power spectrum Baseline: EF (01) - T6 (06)
Timerange: 00/06:20:39 to 00/06:24:09

Plot file version 17 created 03-OCT-2017 13:27:12

J1108+4330 EG096C.UVDATA.1

Freq = 4.7990 GHz, Bw = 32.000 MH No calibration applied and no bandpass applied

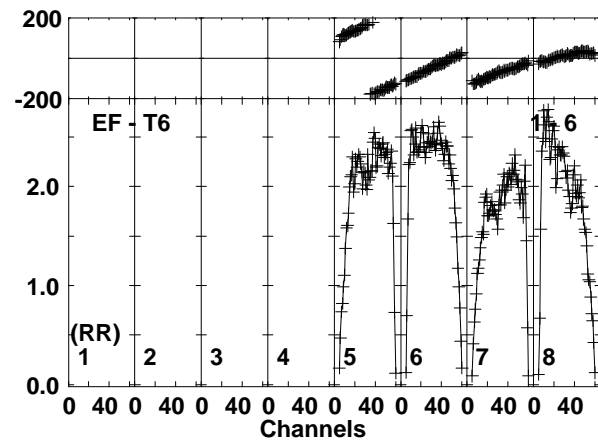
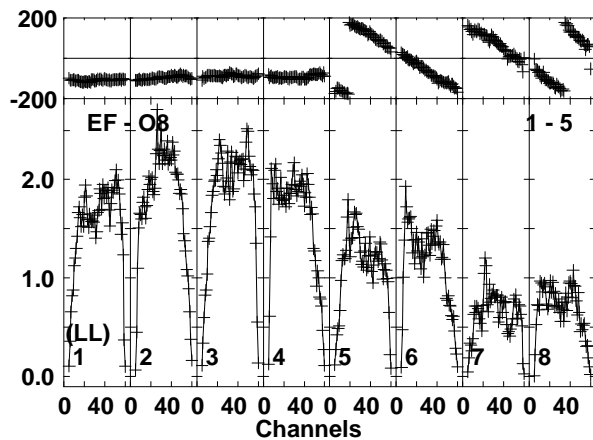
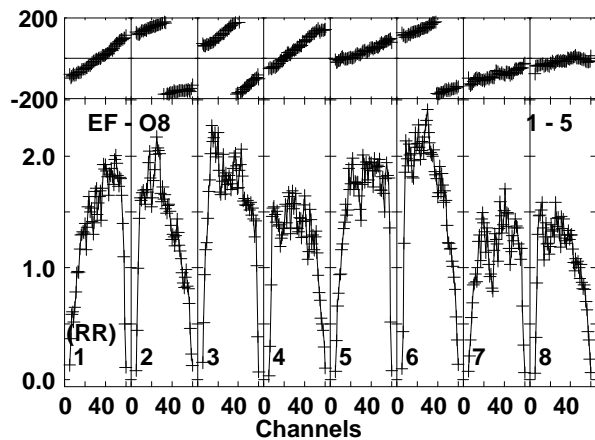
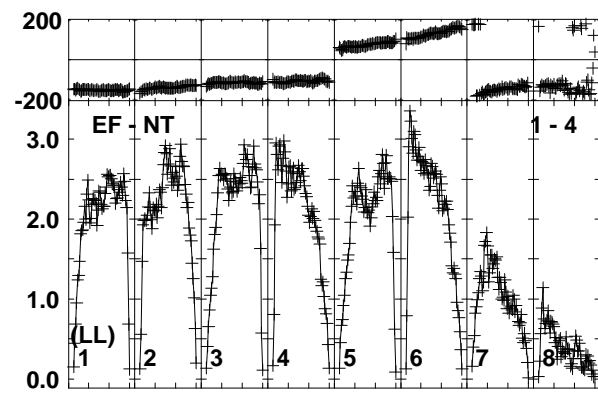
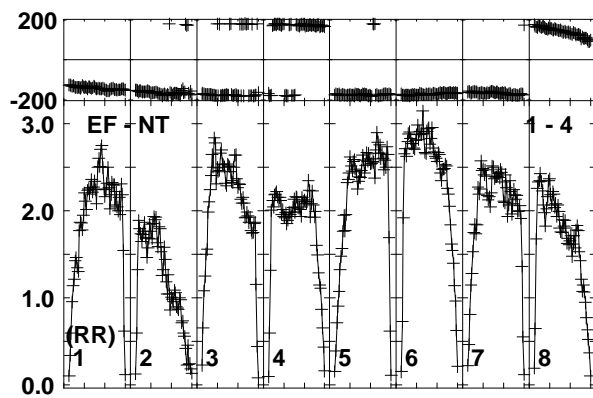
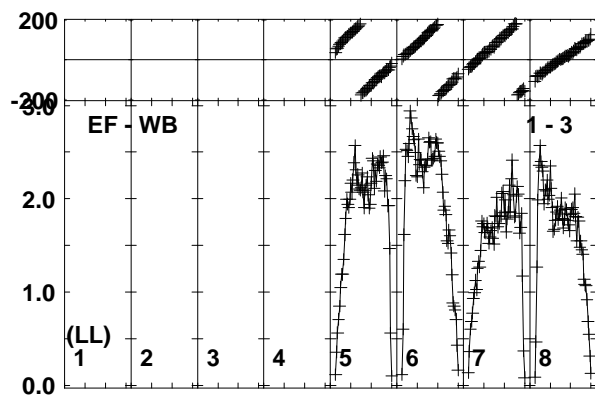
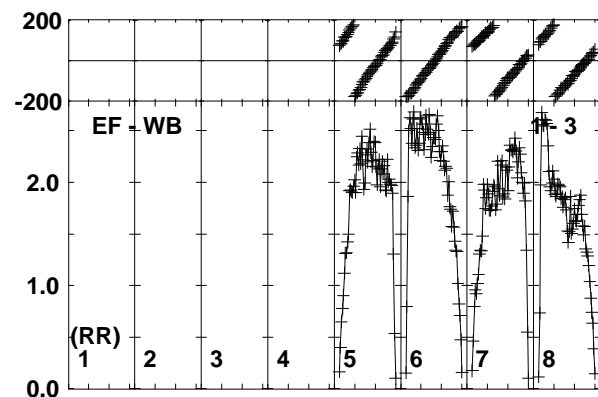
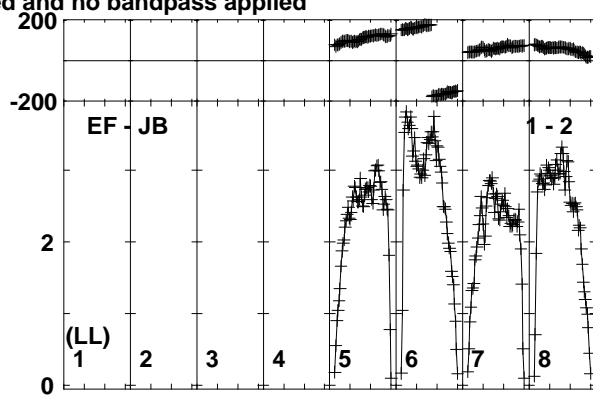
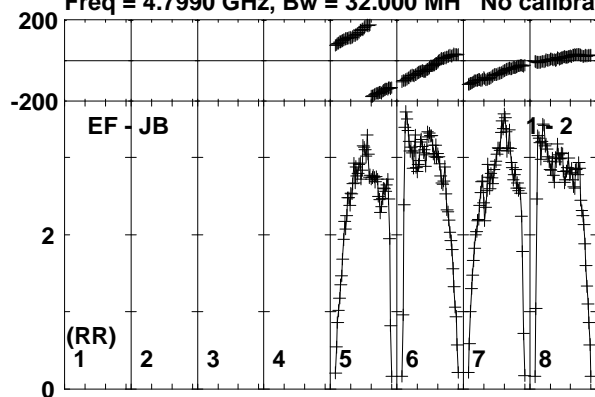

Lower frame: Milli Ampl Jy Top frame: Phas deg
Vector averaged cross-power spectrum Baseline: EF (01) - JB (02)
Timerange: 00/06:24:10 to 00/06:25:38

Plot file version 18 created 03-OCT-2017 13:27:13

J1108+4330 EG096C.UVDATA.1

Freq = 4.7990 GHz, Bw = 32.000 MH No calibration applied and no bandpass applied

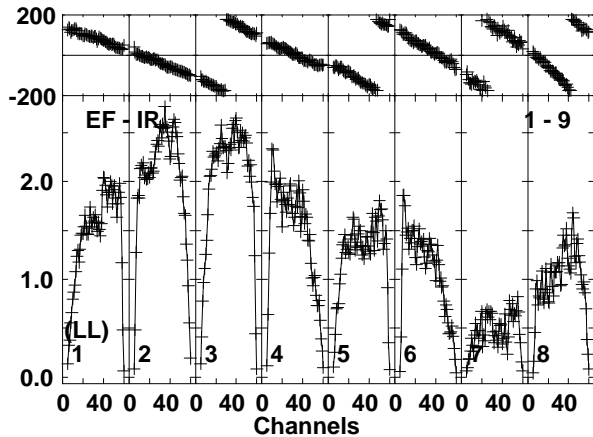
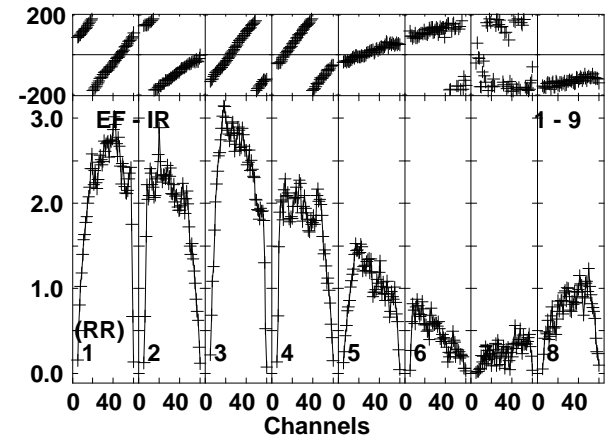
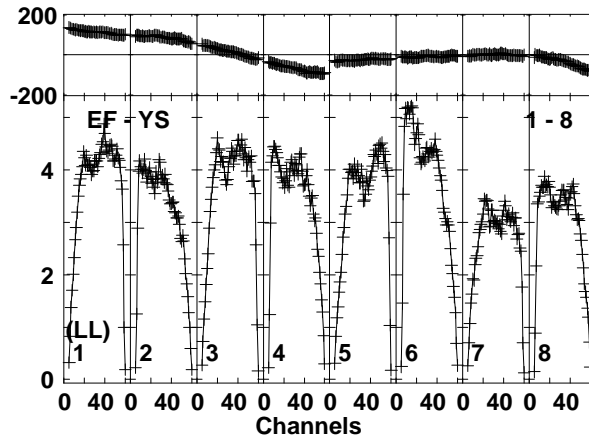
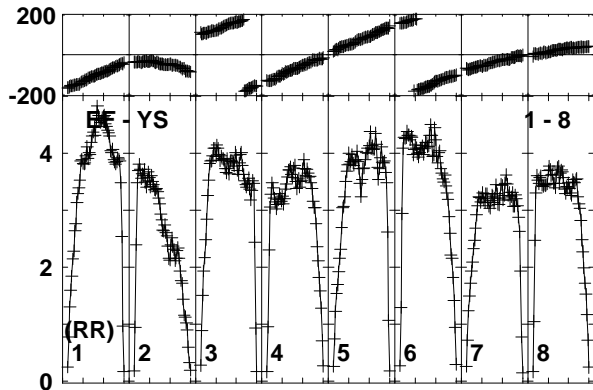
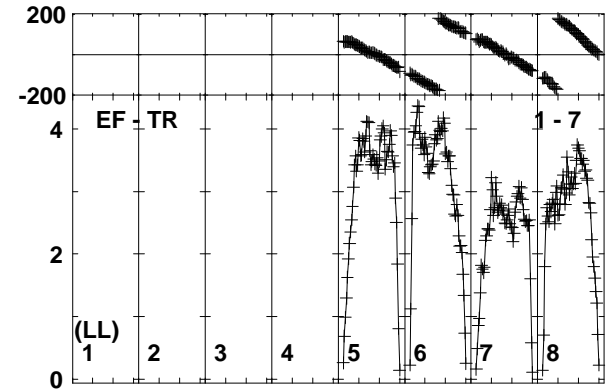
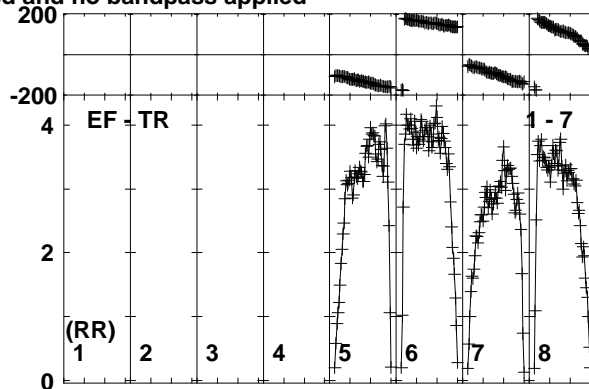
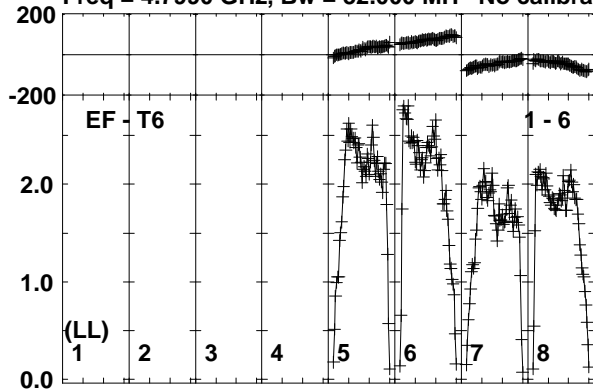

Lower frame: Milli Ampl Jy Top frame: Phas deg
Vector averaged cross-power spectrum Baseline: EF (01) - T6 (06)
Timerange: 00/06:24:10 to 00/06:25:38

Plot file version 19 created 03-OCT-2017 13:27:13

ARUMA EG096C.UVDATA.1

Freq = 4.7990 GHz, Bw = 32.000 MH No calibration applied and no bandpass applied

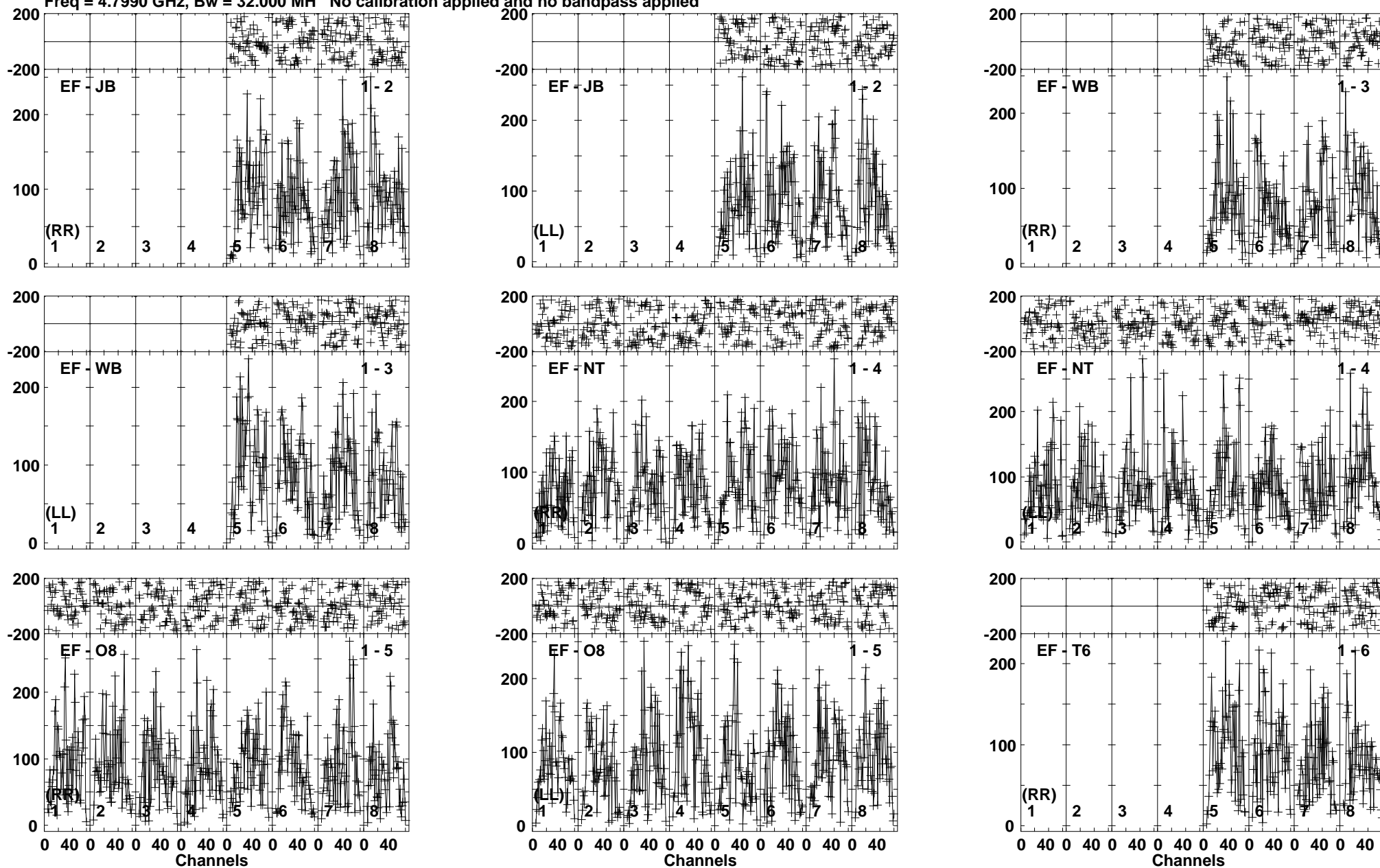

Lower frame: Micro Ampl Jy Top frame: Phas deg
Vector averaged cross-power spectrum Baseline: EF (01) - JB (02)
Timerange: 00/06:25:39 to 00/06:29:08

Plot file version 20 created 03-OCT-2017 13:27:13

ARUMA EG096C.UVDATA.1

Freq = 4.7990 GHz, Bw = 32.000 MH No calibration applied and no bandpass applied

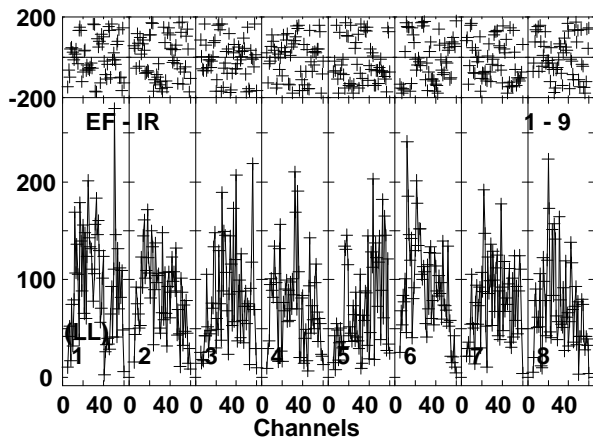
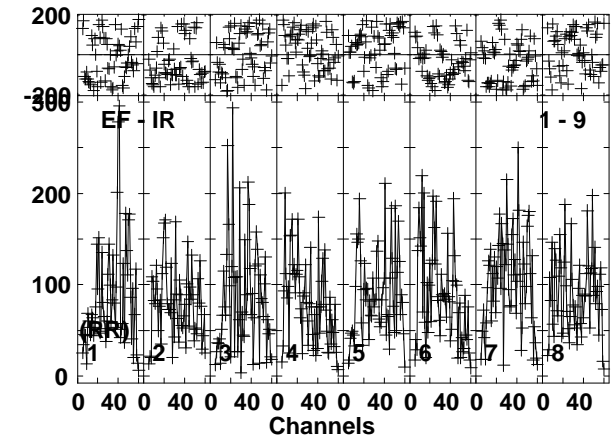
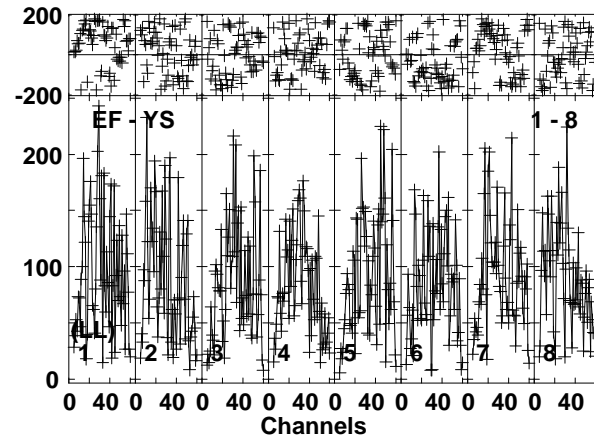
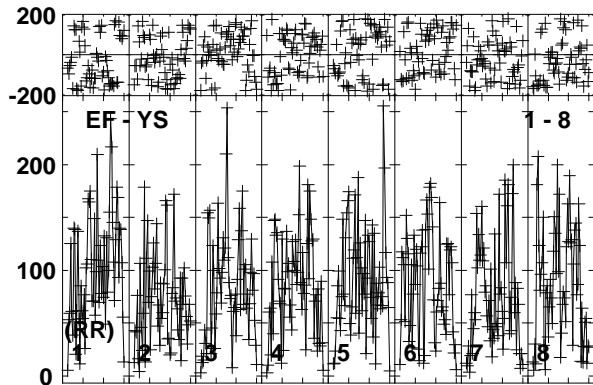
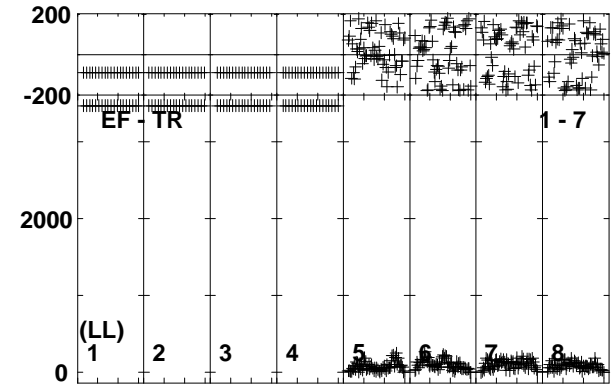
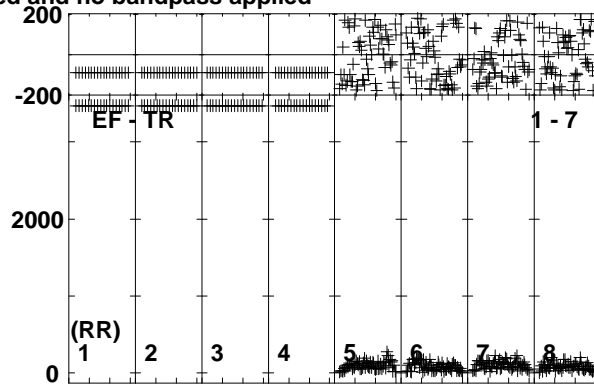
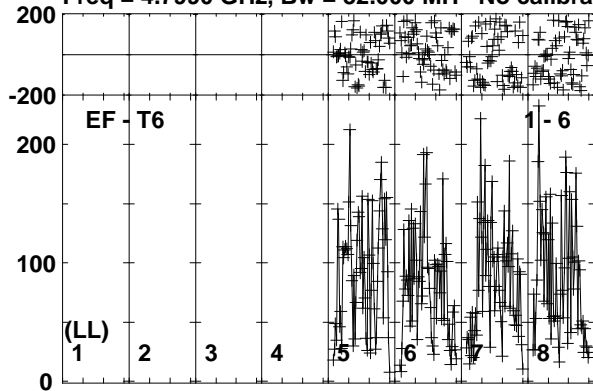

Lower frame: Micro Ampl Jy Top frame: Phas deg
Vector averaged cross-power spectrum Baseline: EF (01) - T6 (06)
Timerange: 00/06:25:39 to 00/06:29:08

Plot file version 21 created 03-OCT-2017 13:27:13

J1108+4330 EG096C.UVDATA.1

Freq = 4.7990 GHz, Bw = 32.000 MH No calibration applied and no bandpass applied

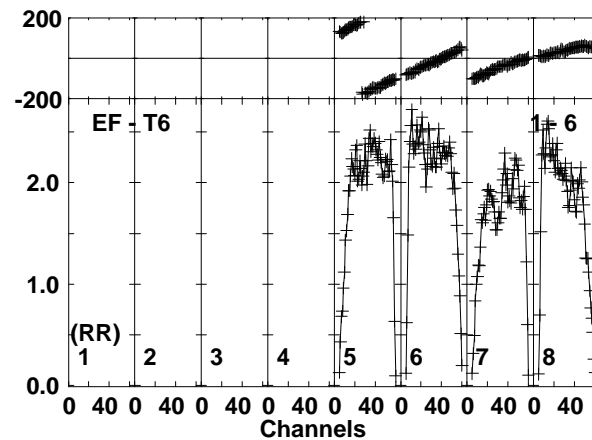
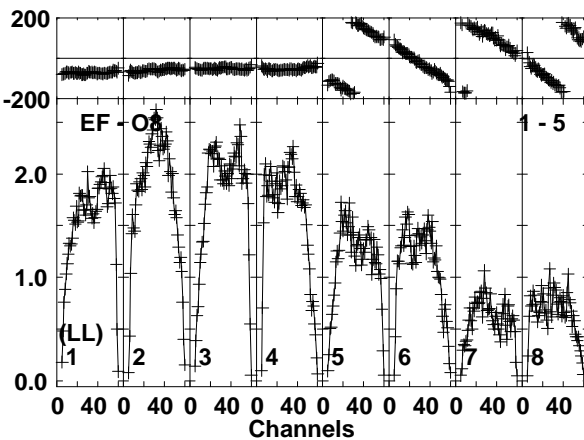
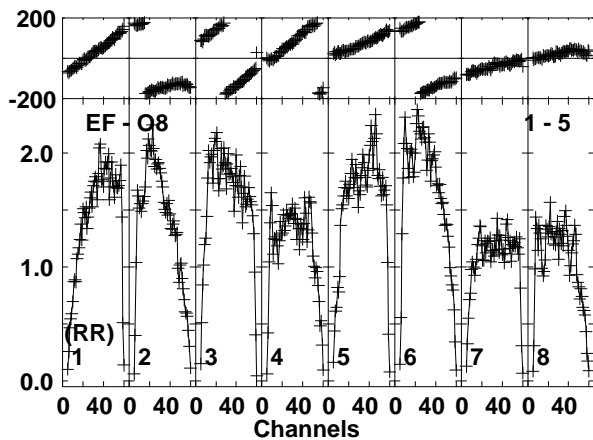
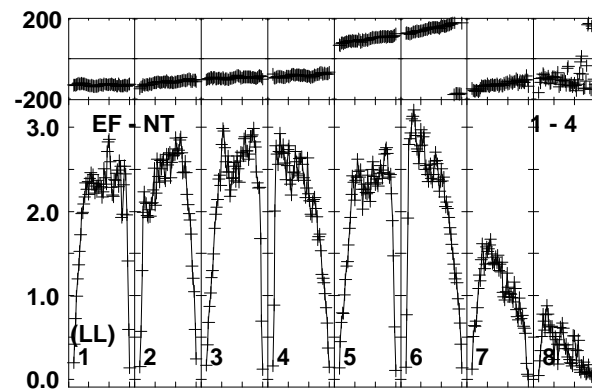
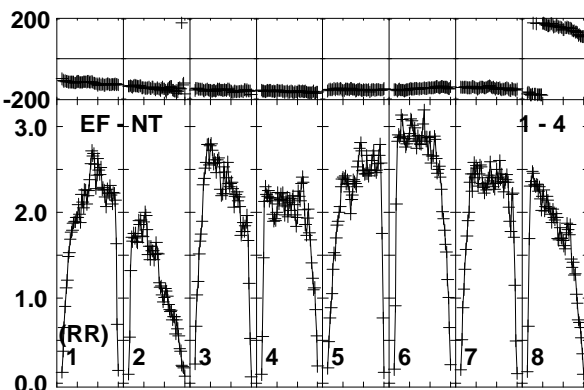
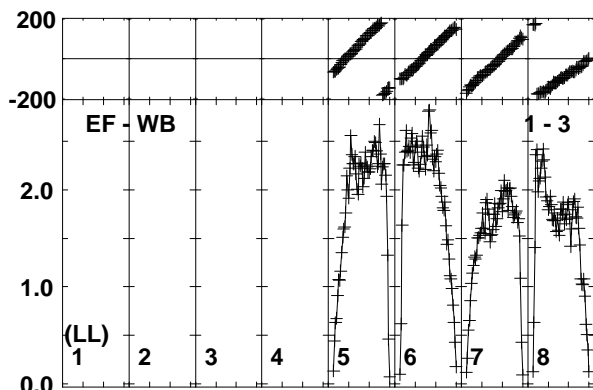
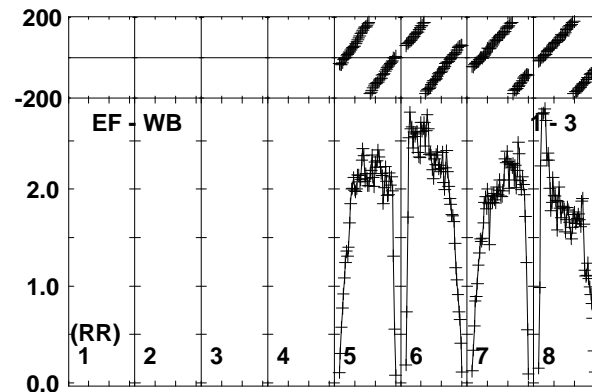
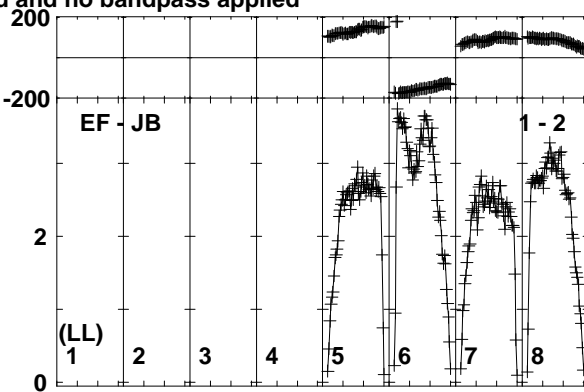
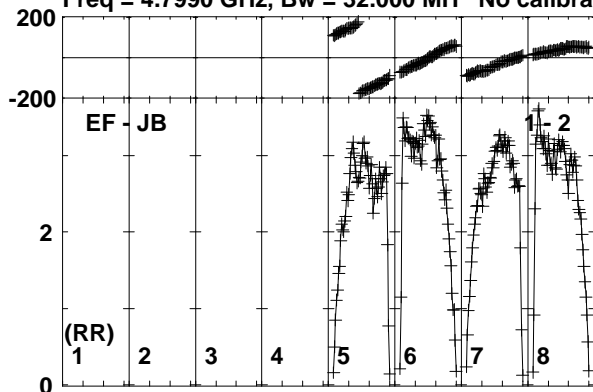

Lower frame: Milli Ampl Jy Top frame: Phas deg
Vector averaged cross-power spectrum Baseline: EF (01) - JB (02)
Timerange: 00/06:29:50 to 00/06:30:48

Plot file version 22 created 03-OCT-2017 13:27:13

J1108+4330 EG096C.UVDATA.1

Freq = 4.7990 GHz, Bw = 32.000 MH No calibration applied and no bandpass applied

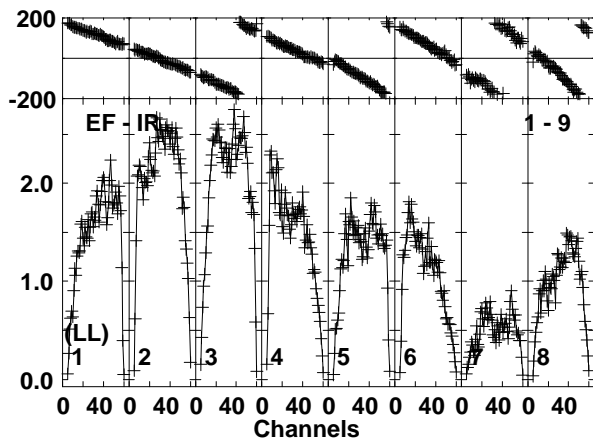
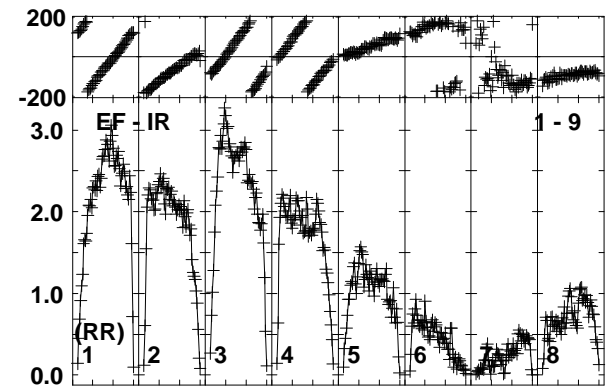
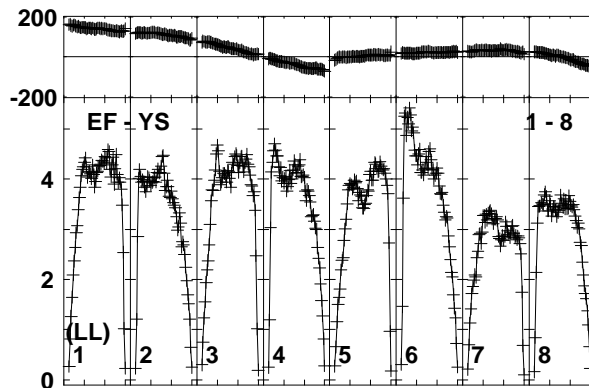
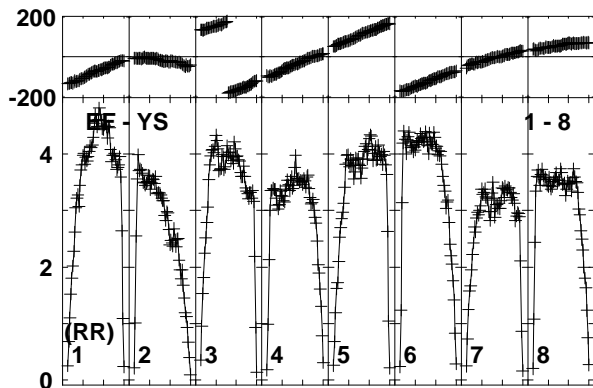
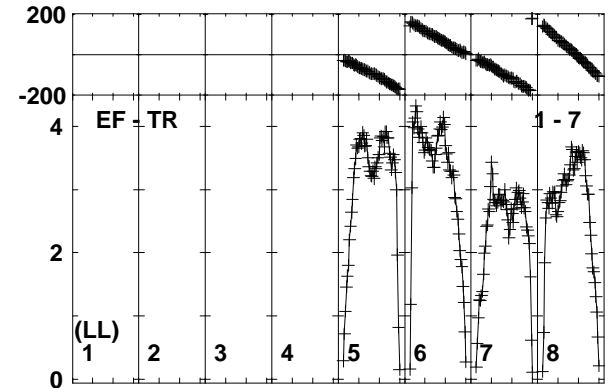
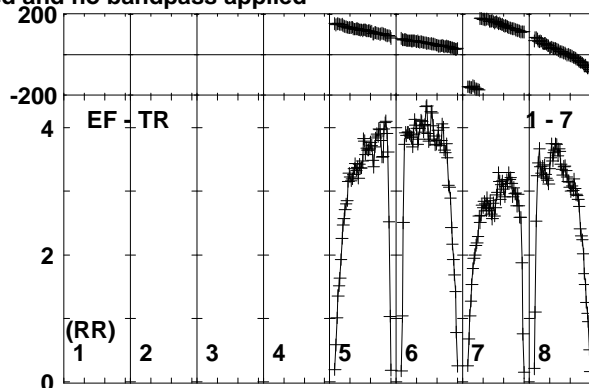
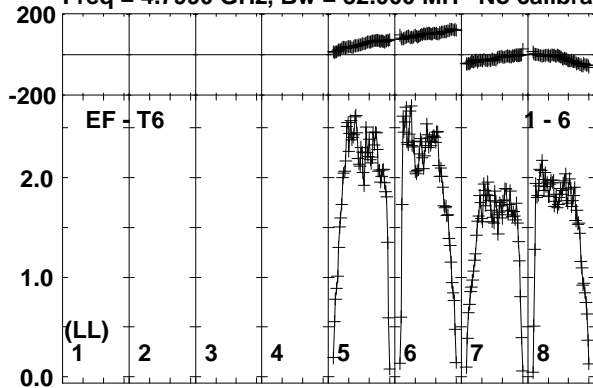

Lower frame: Milli Ampl Jy Top frame: Phas deg
Vector averaged cross-power spectrum Baseline: EF (01) - T6 (06)
Timerange: 00/06:29:50 to 00/06:30:48

Plot file version 23 created 03-OCT-2017 13:27:14

ARUMA EG096C.UVDATA.1

Freq = 4.7990 GHz, Bw = 32.000 MH No calibration applied and no bandpass applied

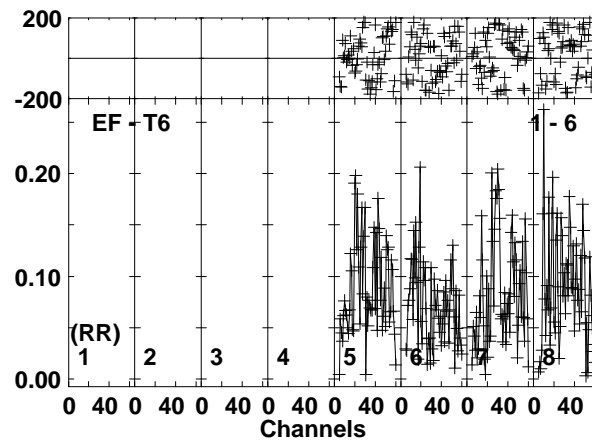
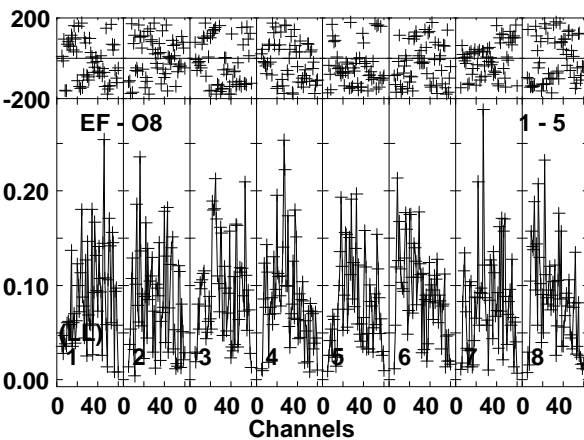
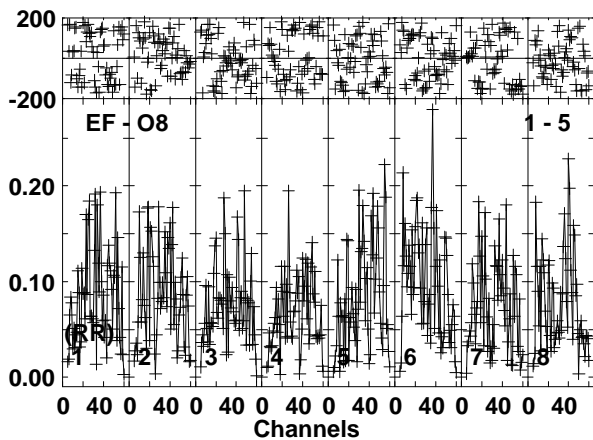
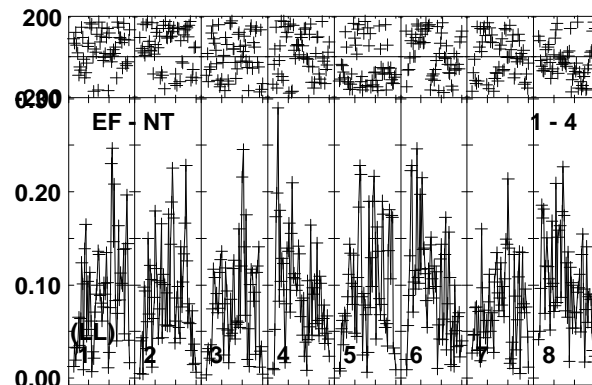
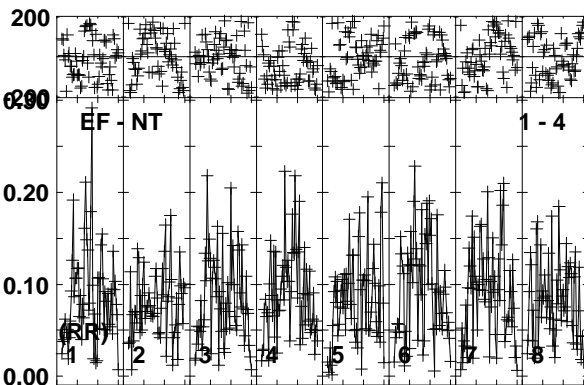
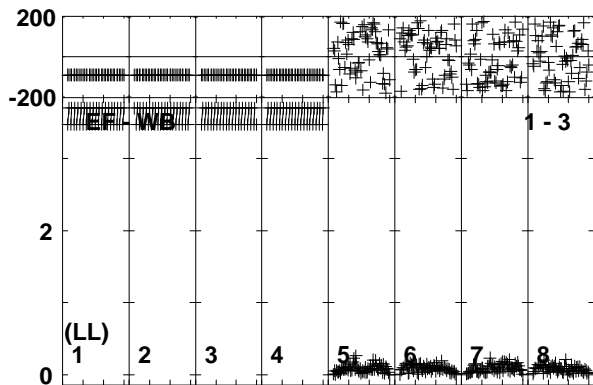
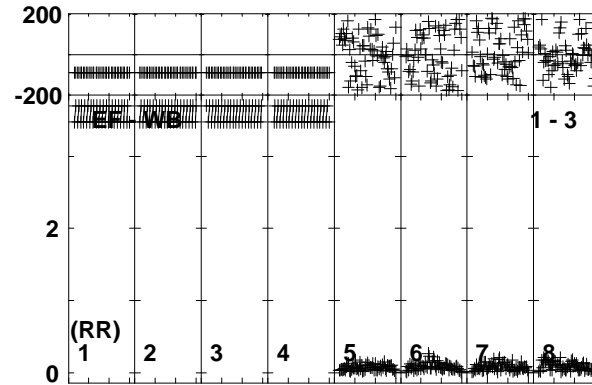
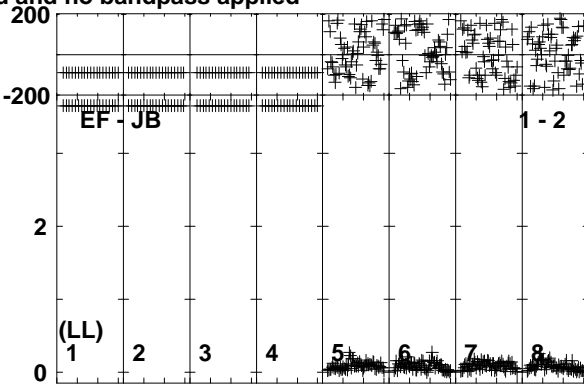
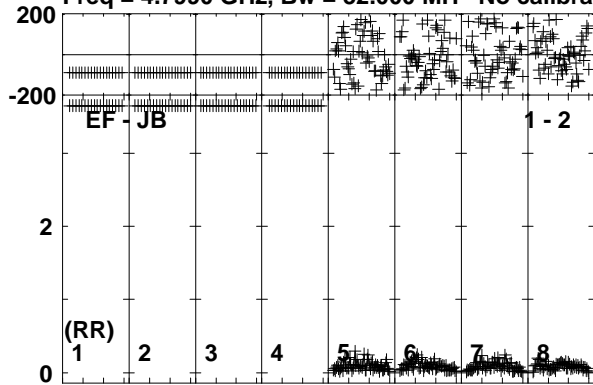

Lower frame: Milli Ampl Jy Top frame: Phas deg
Vector averaged cross-power spectrum Baseline: EF (01) - JB (02)
Timerange: 00/06:30:49 to 00/06:34:18

Plot file version 24 created 03-OCT-2017 13:27:14

ARUMA EG096C.UVDATA.1

Freq = 4.7990 GHz, Bw = 32.000 MH No calibration applied and no bandpass applied

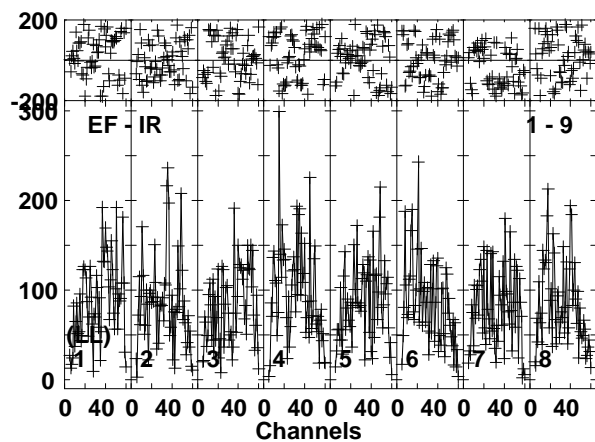
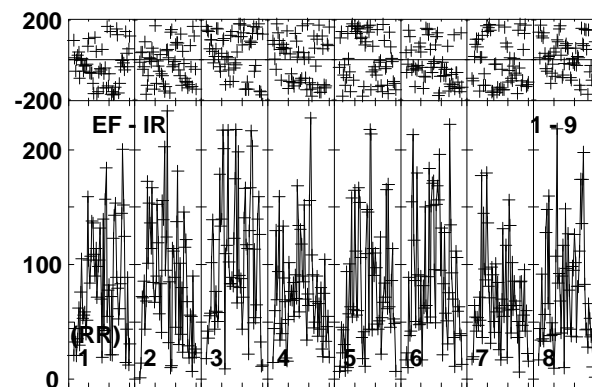
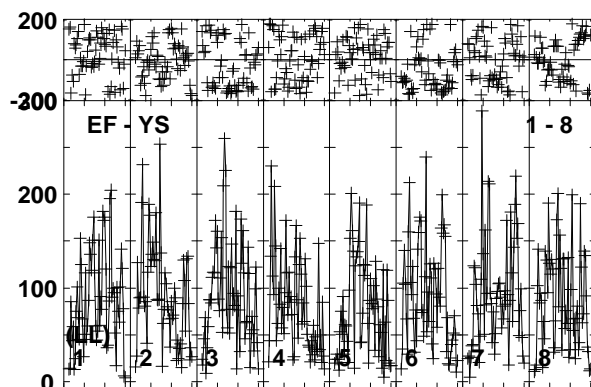
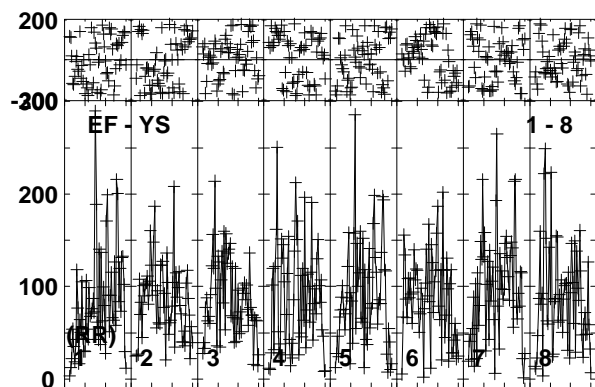
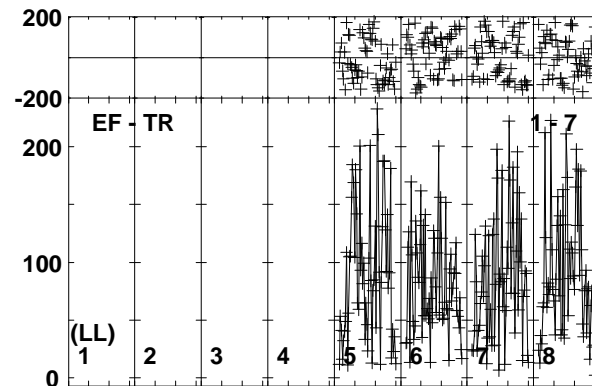
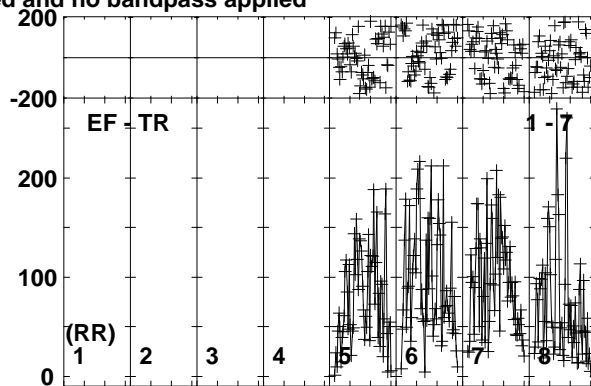
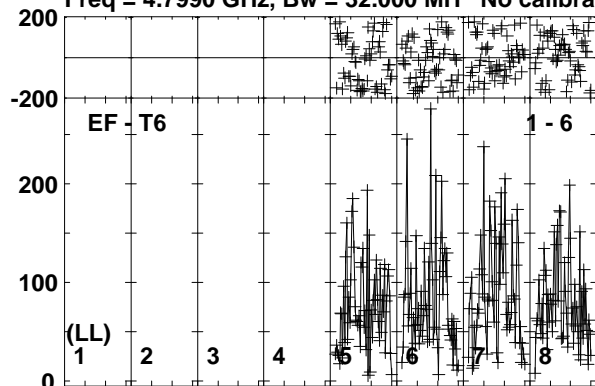

Lower frame: Micro Ampl Jy Top frame: Phas deg
Vector averaged cross-power spectrum Baseline: EF (01) - T6 (06)
Timerange: 00/06:30:49 to 00/06:34:18

Plot file version 25 created 03-OCT-2017 13:27:16

J1108+4330 EG096C.UVDATA.1

Freq = 4.7990 GHz, Bw = 32.000 MH No calibration applied and no bandpass applied

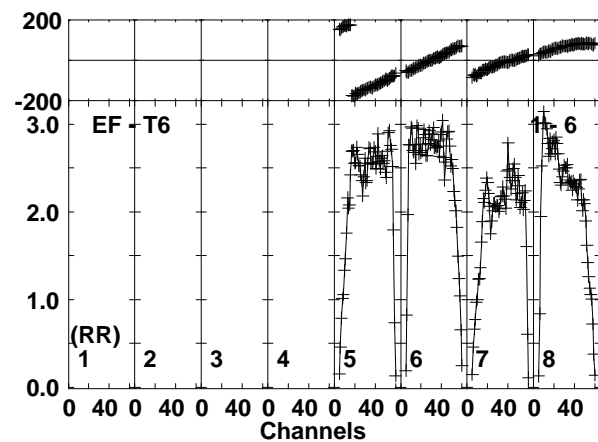
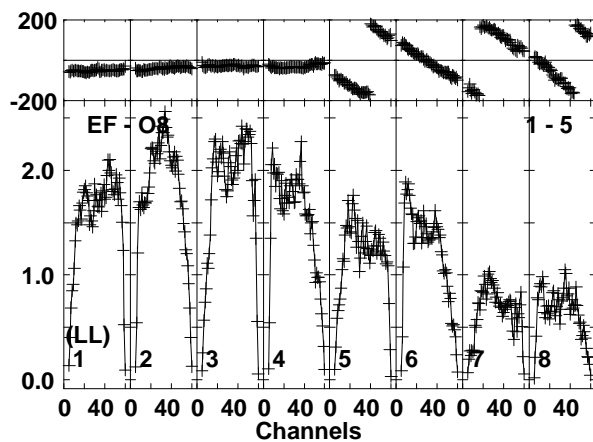
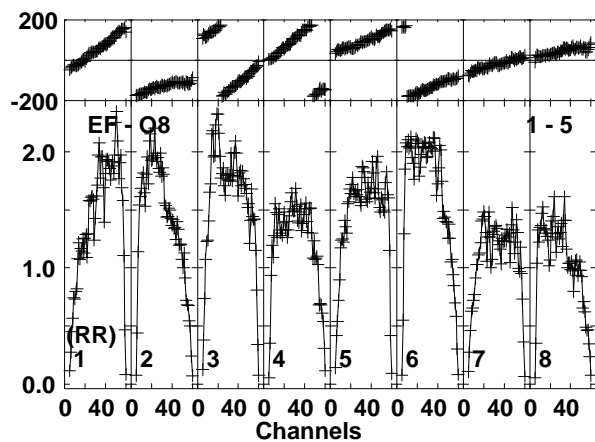
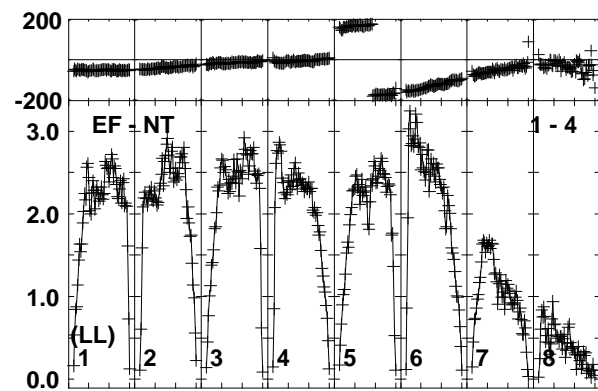
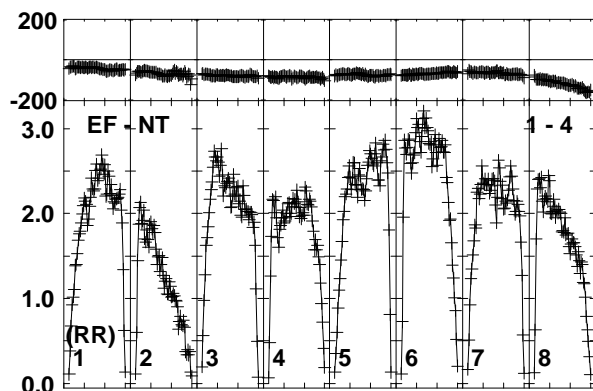
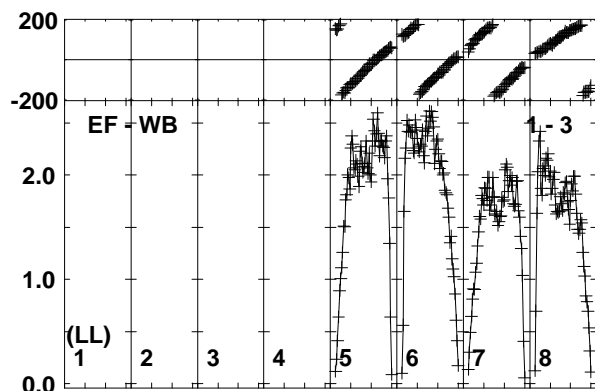
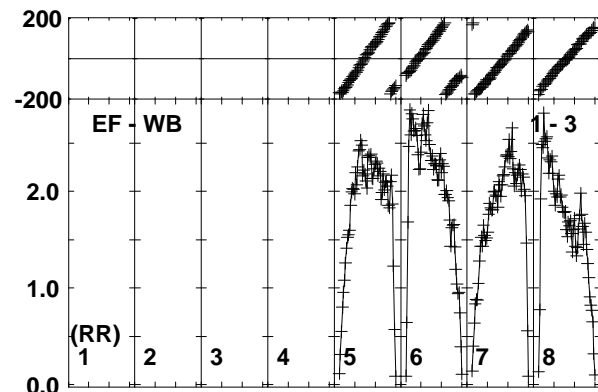
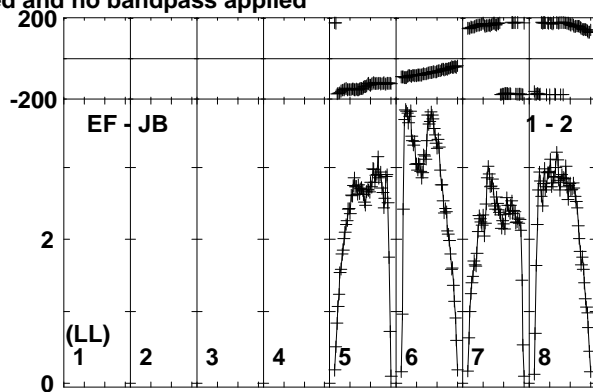
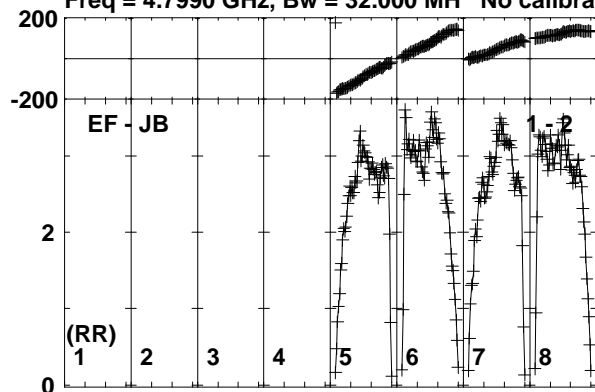

Lower frame: Milli Ampl Jy Top frame: Phas deg
Vector averaged cross-power spectrum Baseline: EF (01) - JB (02)
Timerange: 00/06:34:19 to 00/06:35:48

Plot file version 26 created 03-OCT-2017 13:27:16

J1108+4330 EG096C.UVDATA.1

Freq = 4.7990 GHz, Bw = 32.000 MH No calibration applied and no bandpass applied

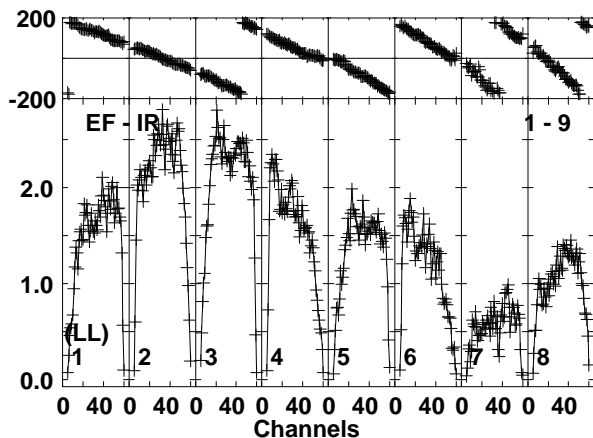
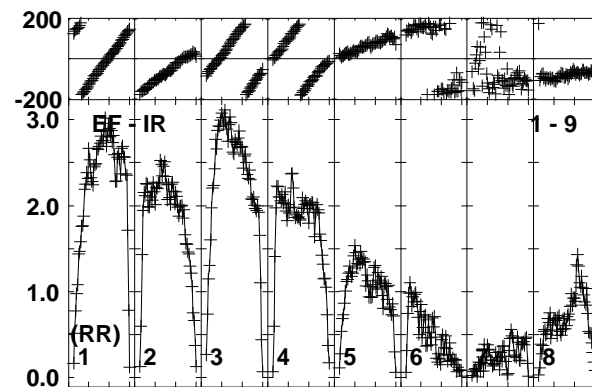
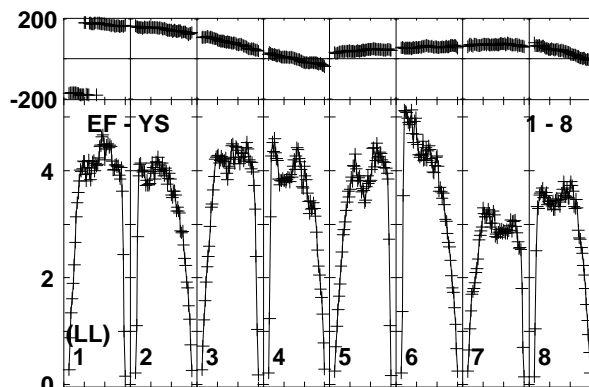
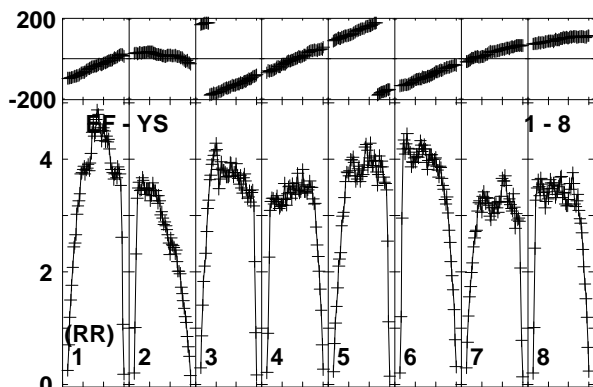
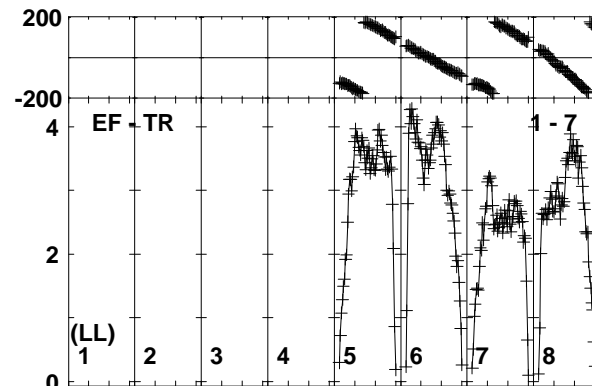
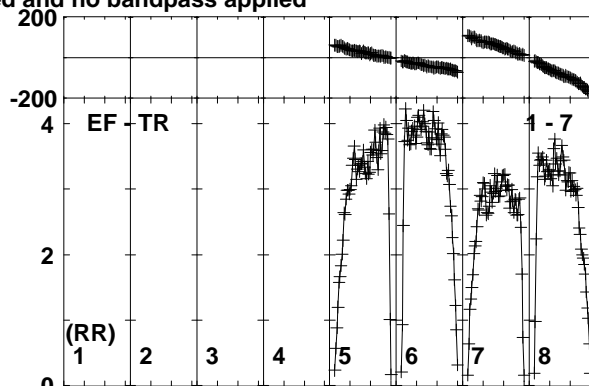
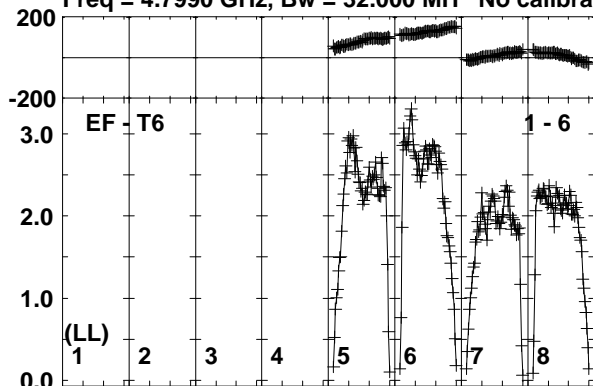

Lower frame: Milli Ampl Jy Top frame: Phas deg
Vector averaged cross-power spectrum Baseline: EF (01) - T6 (06)
Timerange: 00/06:34:19 to 00/06:35:48

Plot file version 27 created 03-OCT-2017 13:27:17

ARUMA EG096C.UVDATA.1

Freq = 4.7990 GHz, Bw = 32.000 MH No calibration applied and no bandpass applied

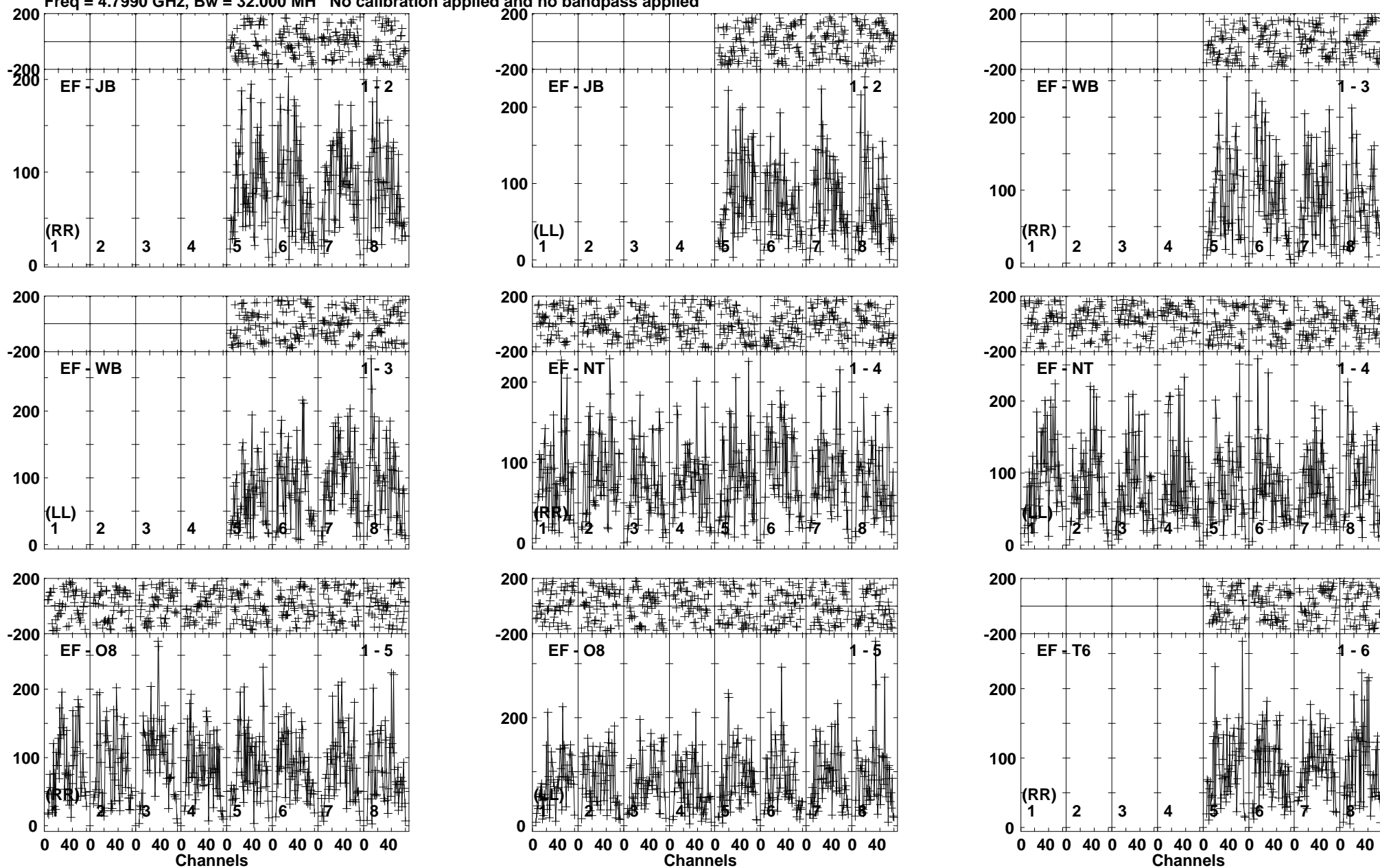

Lower frame: Micro Ampl Jy Top frame: Phas deg
Vector averaged cross-power spectrum Baseline: EF (01) - JB (02)
Timerange: 00/06:35:49 to 00/06:39:19

Plot file version 28 created 03-OCT-2017 13:27:17

ARUMA EG096C.UVDATA.1

Freq = 4.7990 GHz, Bw = 32.000 MH No calibration applied and no bandpass applied

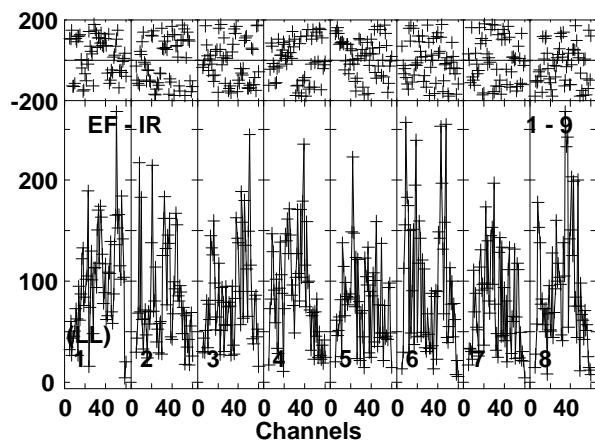
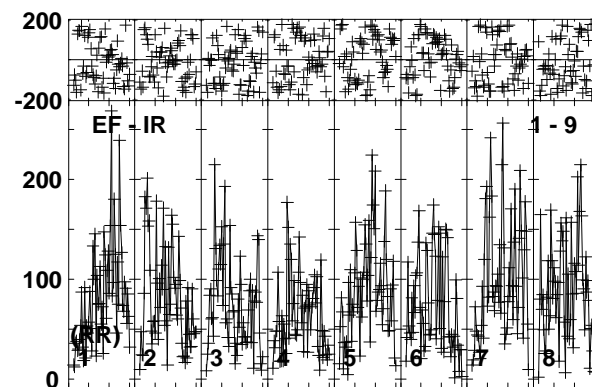
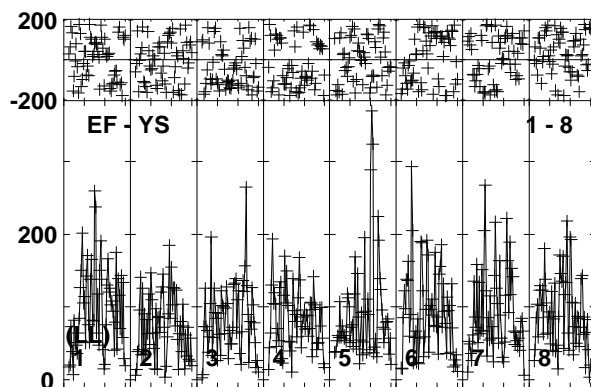
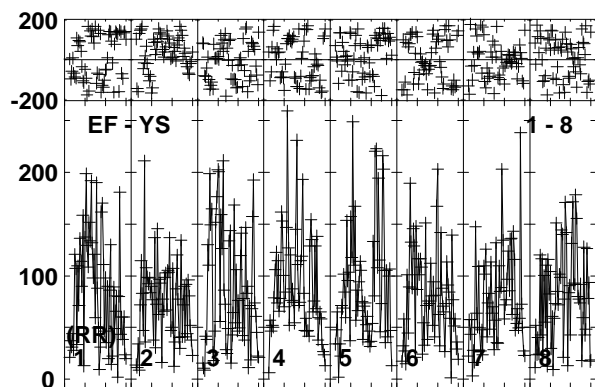
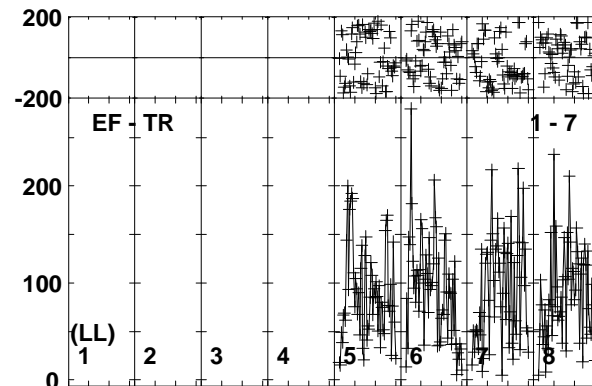
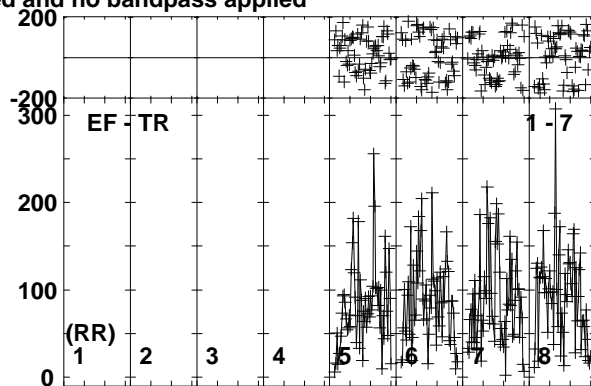
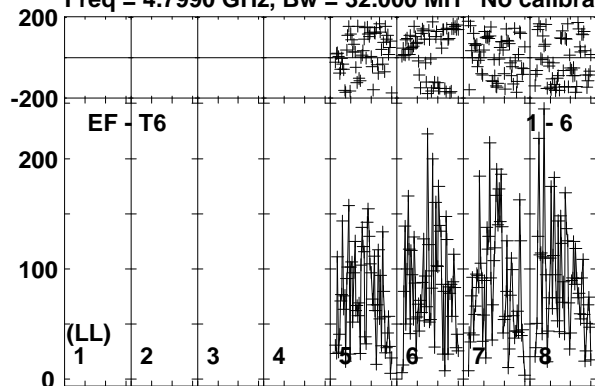

Lower frame: Micro Ampl Jy Top frame: Phas deg
Vector averaged cross-power spectrum Baseline: EF (01) - T6 (06)
Timerange: 00/06:35:49 to 00/06:39:19

Plot file version 29 created 03-OCT-2017 13:27:17

J1108+4330 EG096C.UVDATA.1

Freq = 4.7990 GHz, Bw = 32.000 MH No calibration applied and no bandpass applied

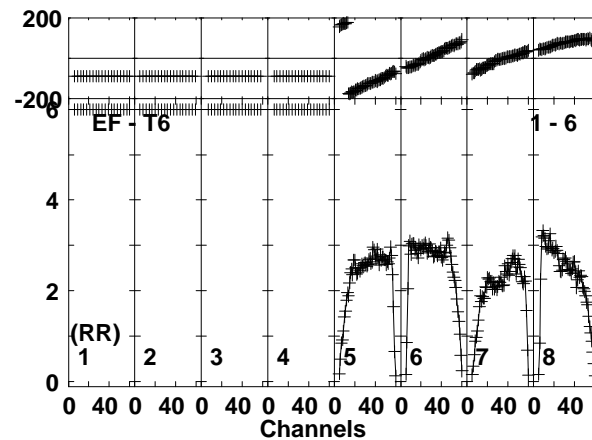
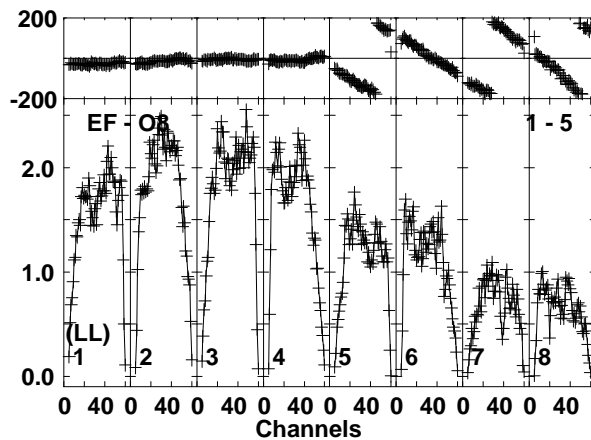
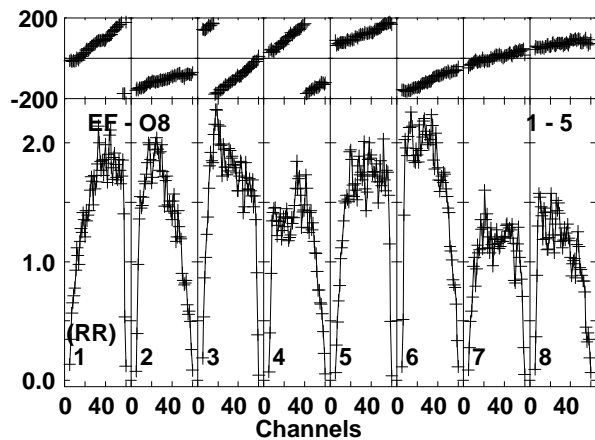
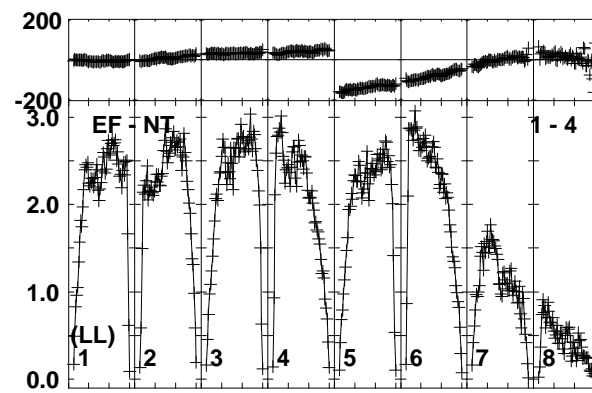
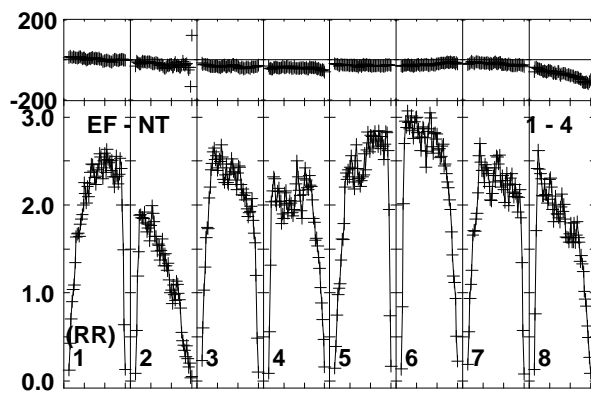
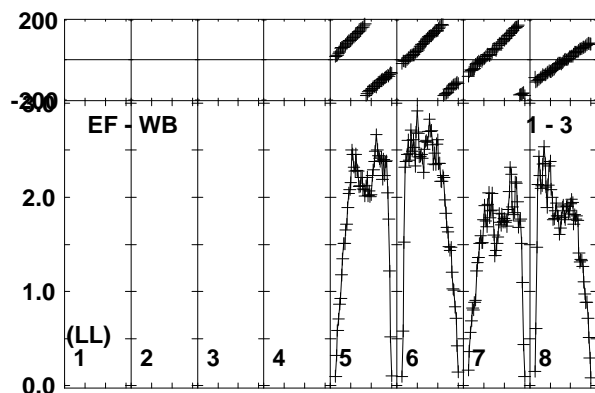
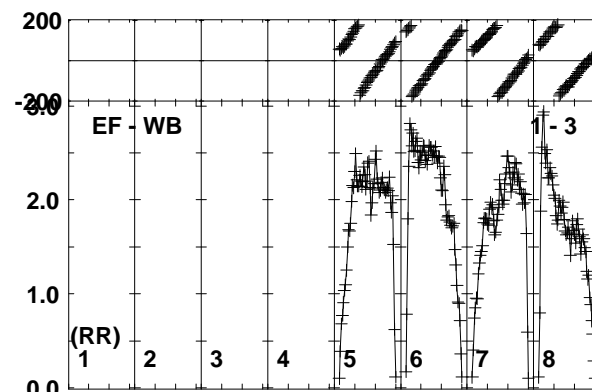
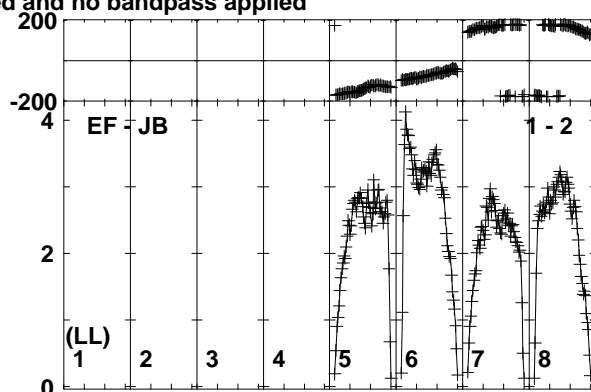
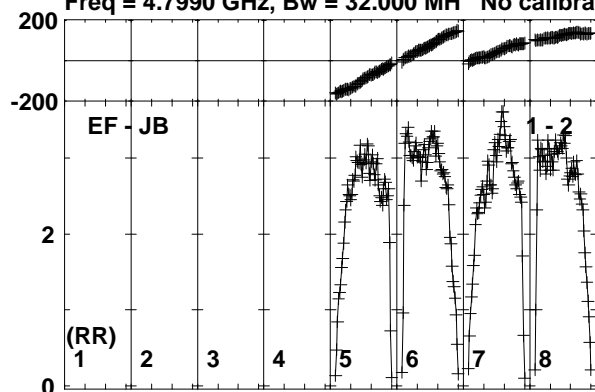

Lower frame: Milli Ampl Jy Top frame: Phas deg
Vector averaged cross-power spectrum Baseline: EF (01) - JB (02)
Timerange: 00/06:39:59 to 00/06:40:58

Plot file version 30 created 03-OCT-2017 13:27:17

J1108+4330 EG096C.UVDATA.1

Freq = 4.7990 GHz, Bw = 32.000 MH No calibration applied and no bandpass applied

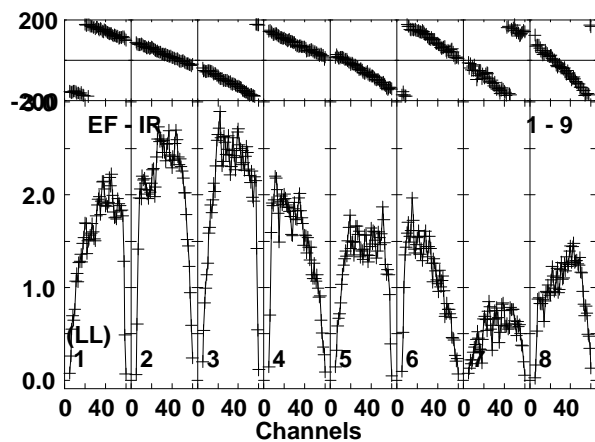
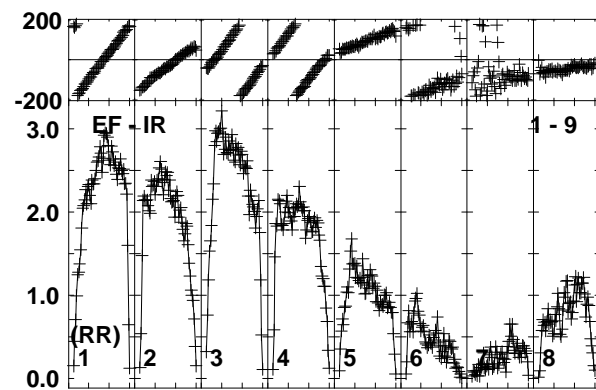
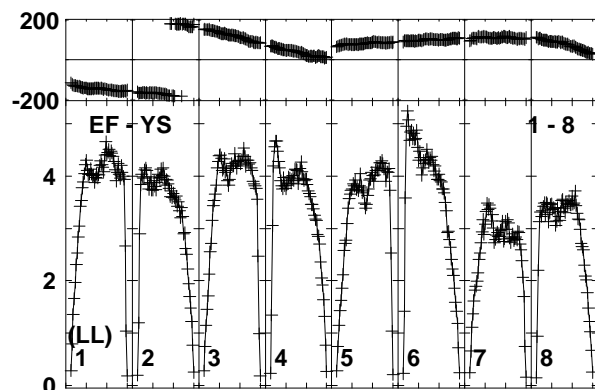
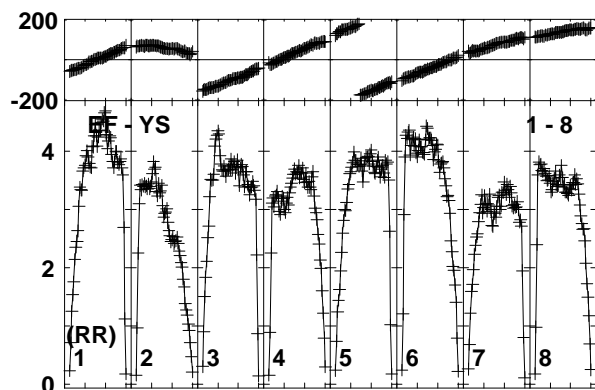
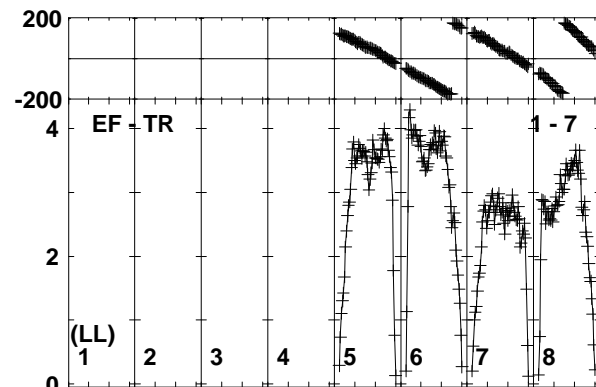
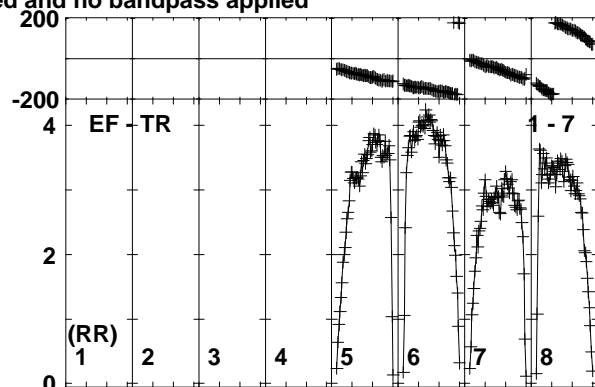
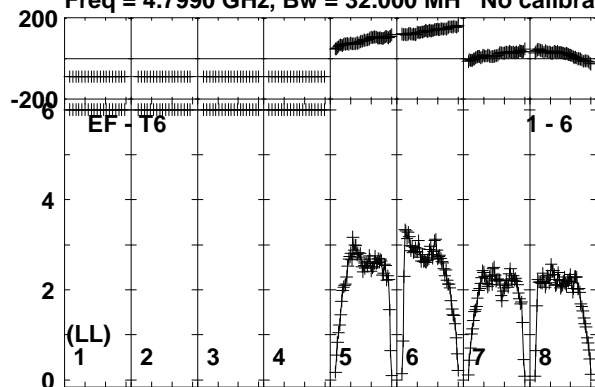

Lower frame: Milli Ampl Jy Top frame: Phas deg
Vector averaged cross-power spectrum Baseline: EF (01) - T6 (06)
Timerange: 00/06:39:59 to 00/06:40:58

Plot file version 31 created 03-OCT-2017 13:27:18

J1112+4301 EG096C.UVDATA.1

Freq = 4.7990 GHz, Bw = 32.000 MH No calibration applied and no bandpass applied

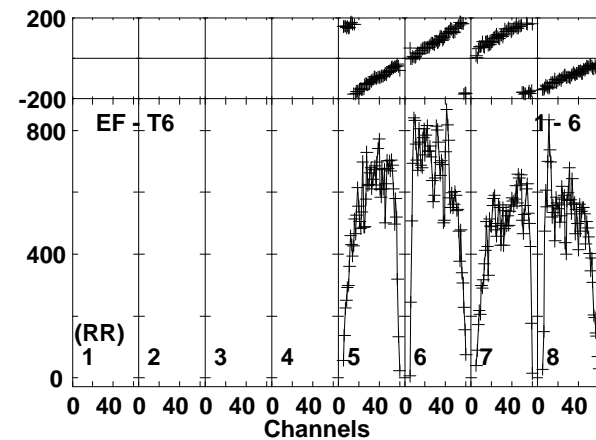
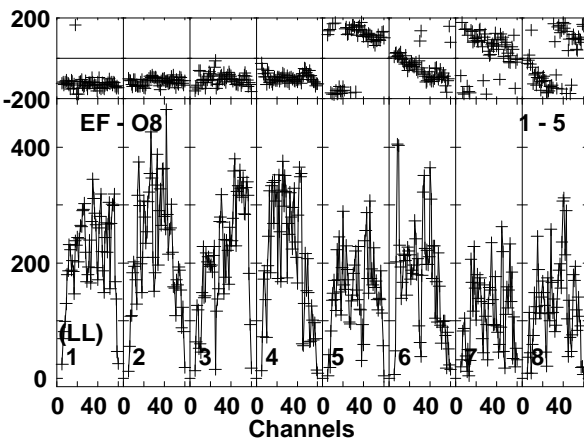
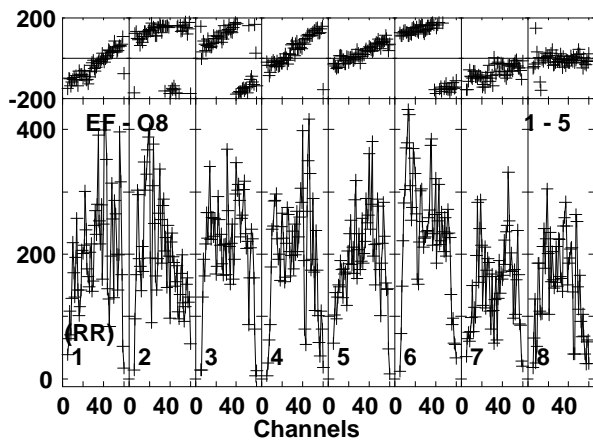
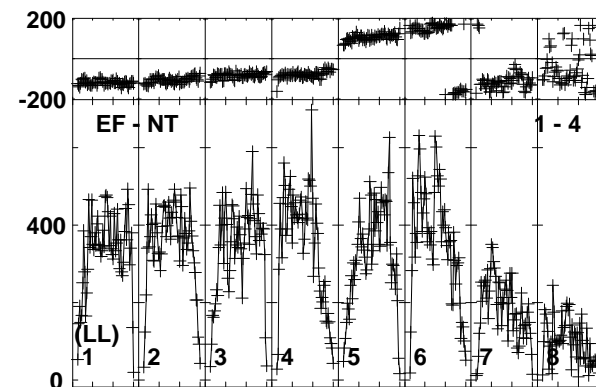
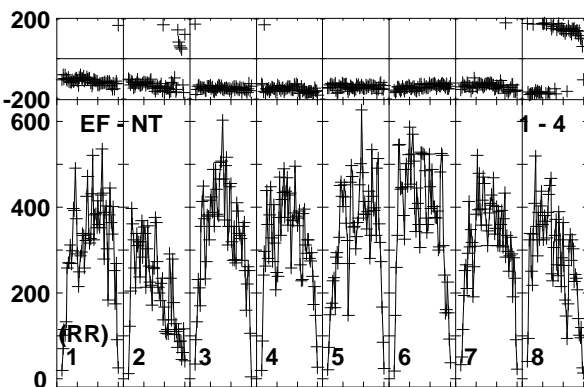
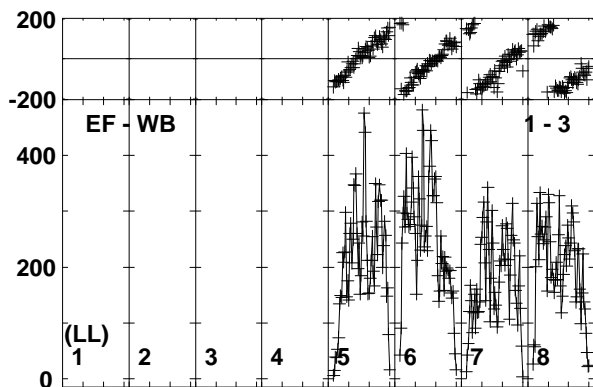
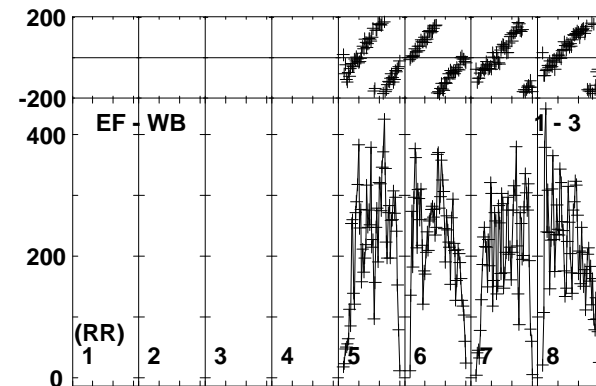
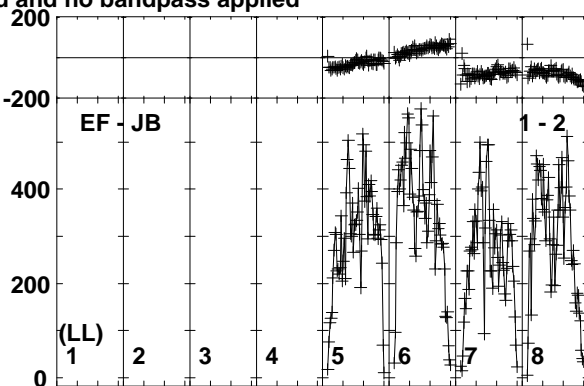
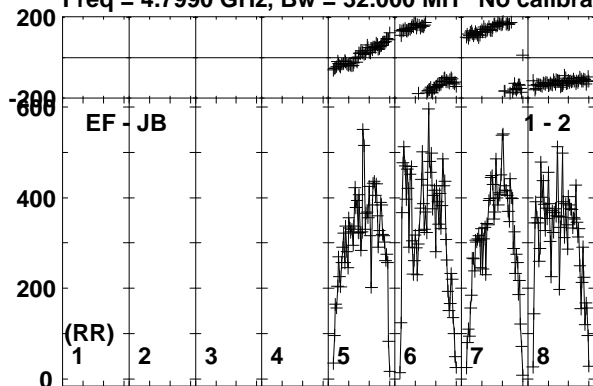

Lower frame: Micro Ampl Jy Top frame: Phas deg
Vector averaged cross-power spectrum Baseline: EF (01) - JB (02)
Timerange: 00/06:40:59 to 00/06:44:29

Plot file version 32 created 03-OCT-2017 13:27:18

J1112+4301 EG096C.UVDATA.1

Freq = 4.7990 GHz, Bw = 32.000 MH No calibration applied and no bandpass applied

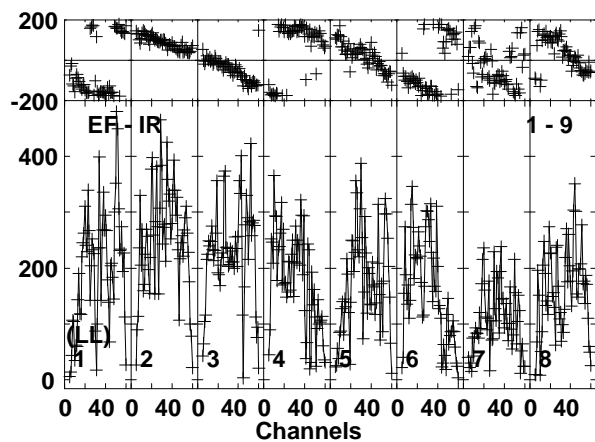
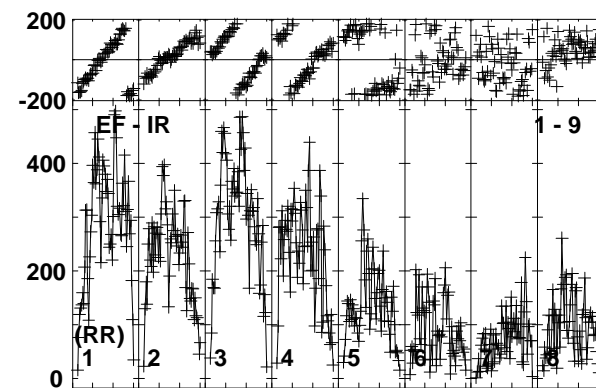
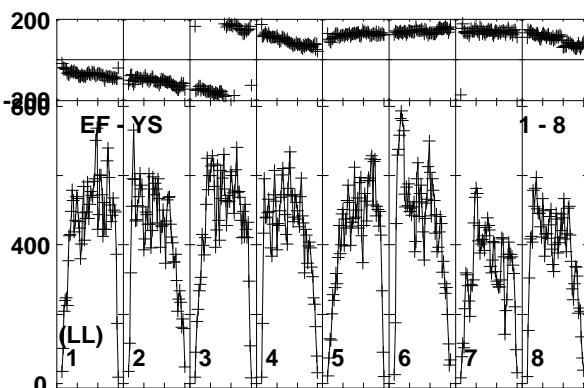
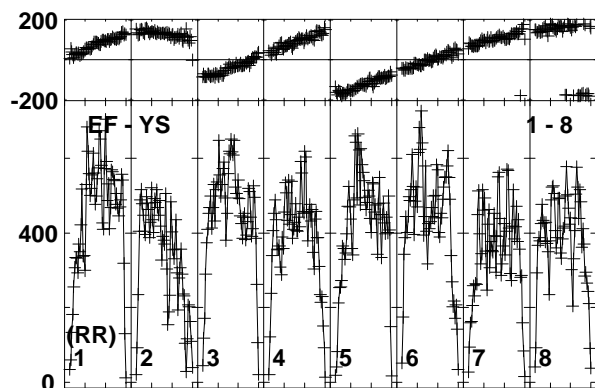
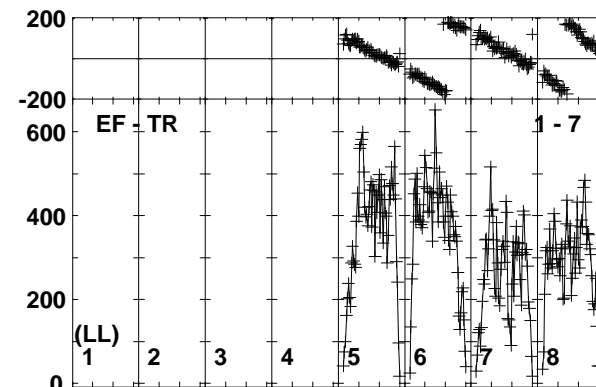
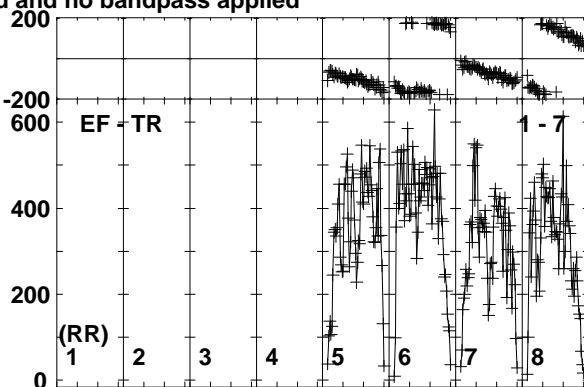
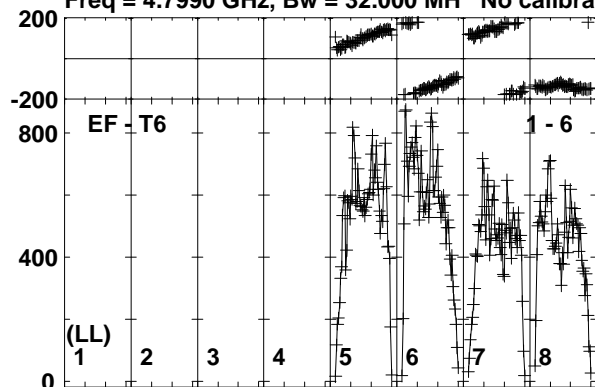

Lower frame: Micro Ampl Jy Top frame: Phas deg
Vector averaged cross-power spectrum Baseline: EF (01) - T6 (06)
Timerange: 00/06:40:59 to 00/06:44:29

Plot file version 33 created 03-OCT-2017 13:27:18

J1108+4330 EG096C.UVDATA.1

Freq = 4.7990 GHz, Bw = 32.000 MH No calibration applied and no bandpass applied

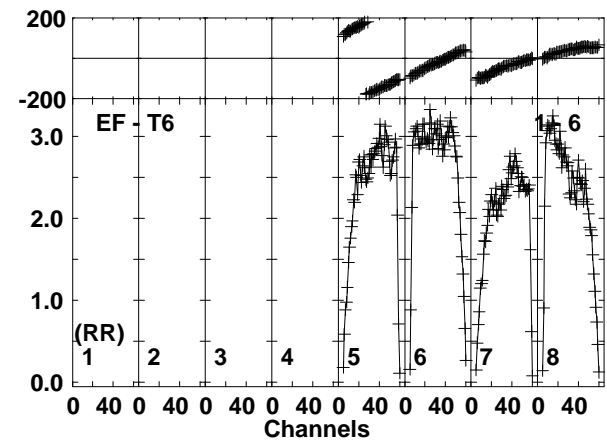
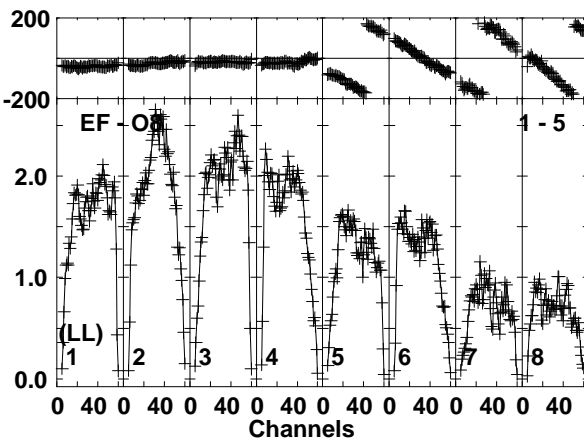
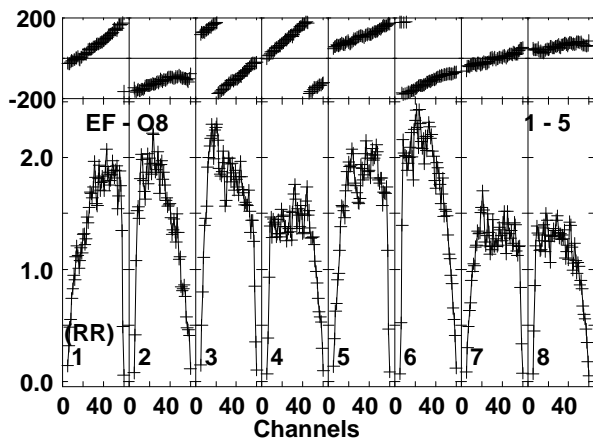
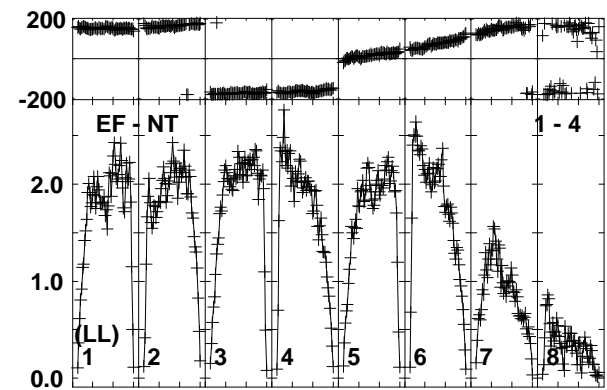
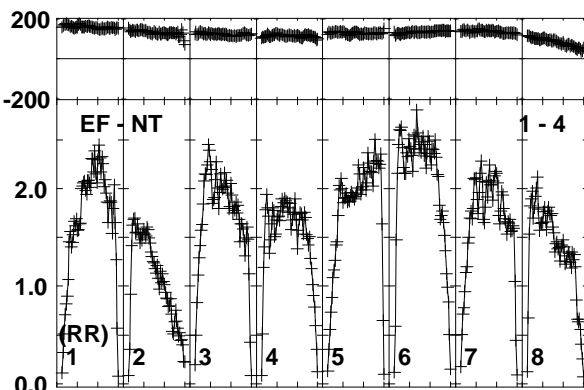
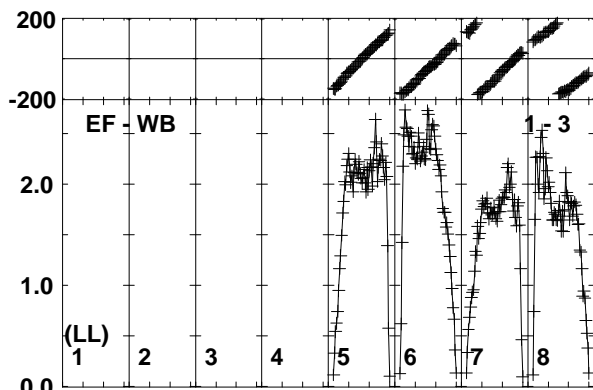
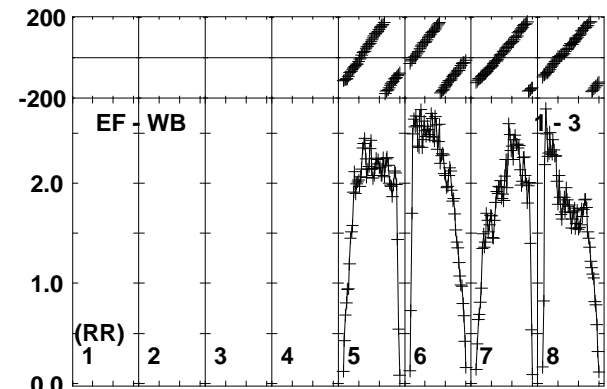
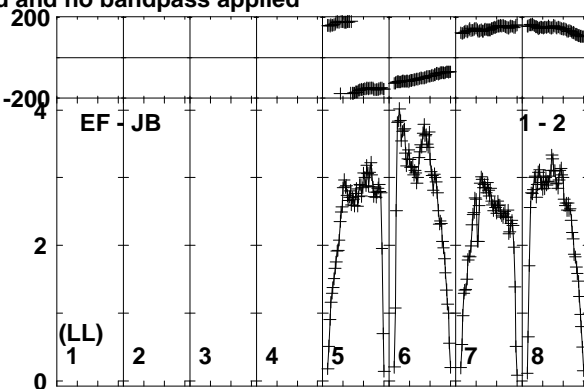
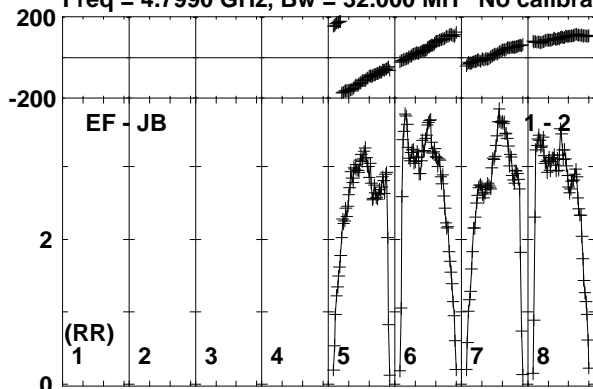

Lower frame: Milli Ampl Jy Top frame: Phas deg
Vector averaged cross-power spectrum Baseline: EF (01) - JB (02)
Timerange: 00/06:44:29 to 00/06:45:58

Plot file version 34 created 03-OCT-2017 13:27:18

J1108+4330 EG096C.UVDATA.1

Freq = 4.7990 GHz, Bw = 32.000 MH No calibration applied and no bandpass applied

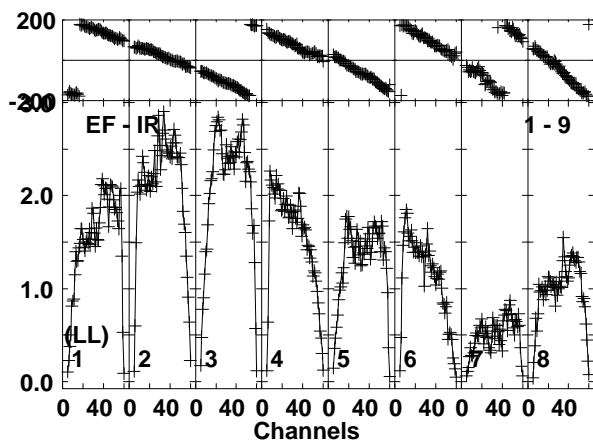
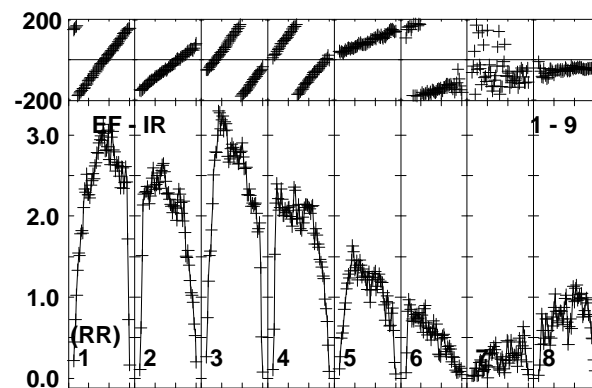
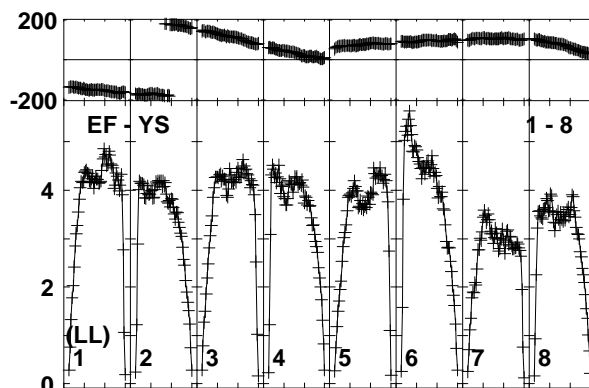
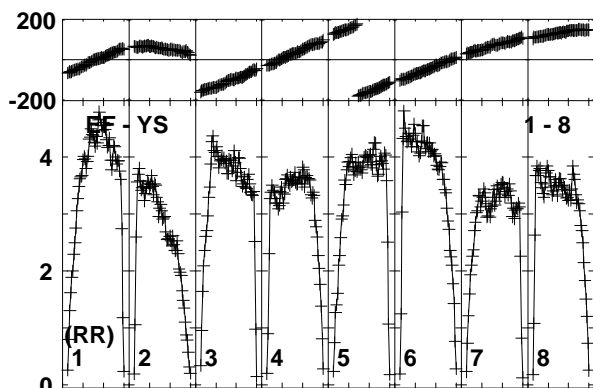
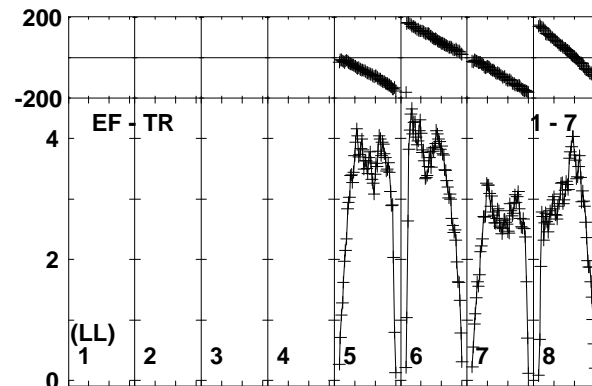
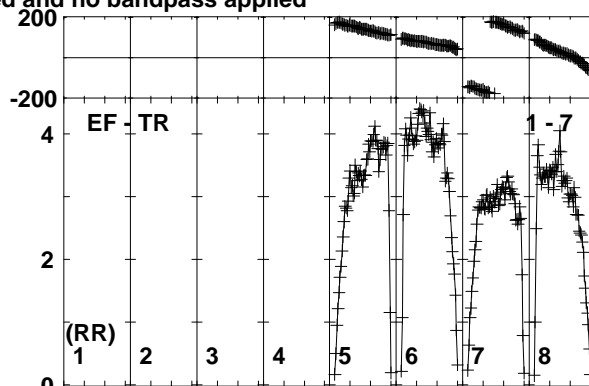
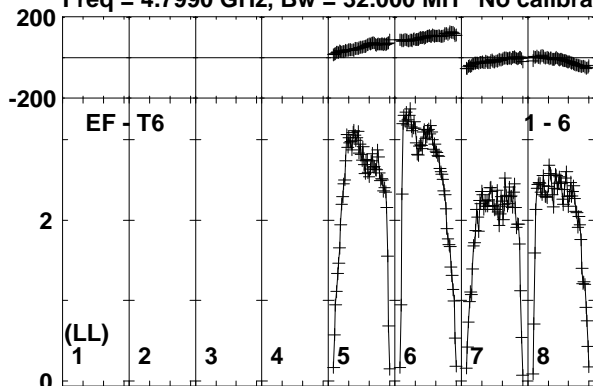

Lower frame: Milli Ampl Jy Top frame: Phas deg
Vector averaged cross-power spectrum Baseline: EF (01) - T6 (06)
Timerange: 00/06:44:29 to 00/06:45:58

Plot file version 35 created 03-OCT-2017 13:27:19

ARUMA EG096C.UVDATA.1

Freq = 4.7990 GHz, Bw = 32.000 MH No calibration applied and no bandpass applied

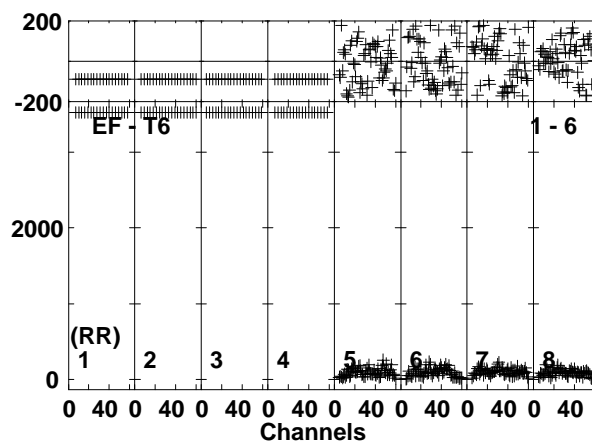
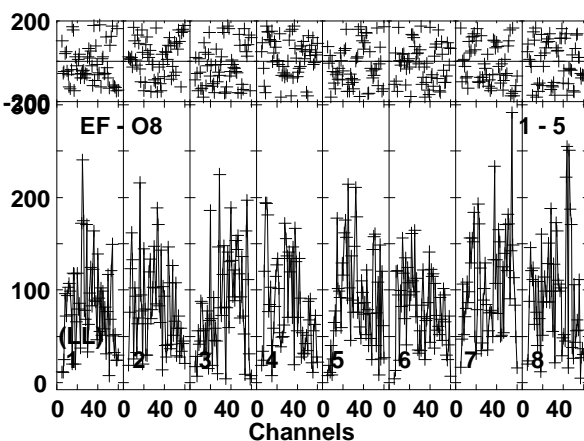
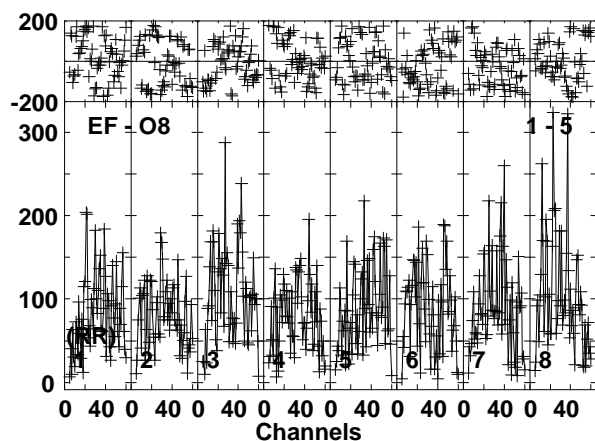
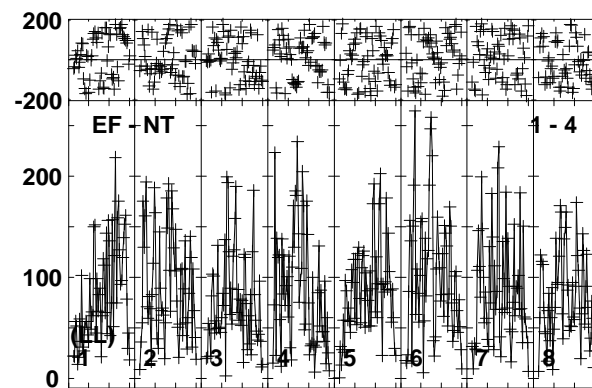
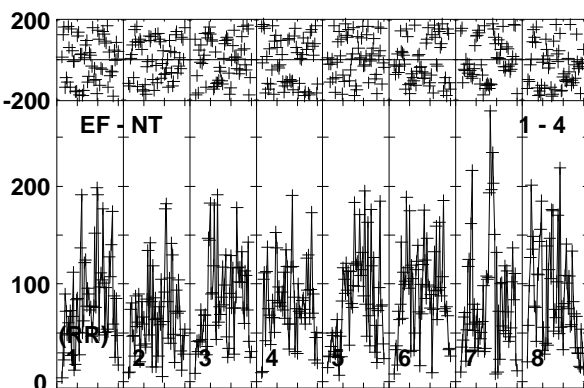
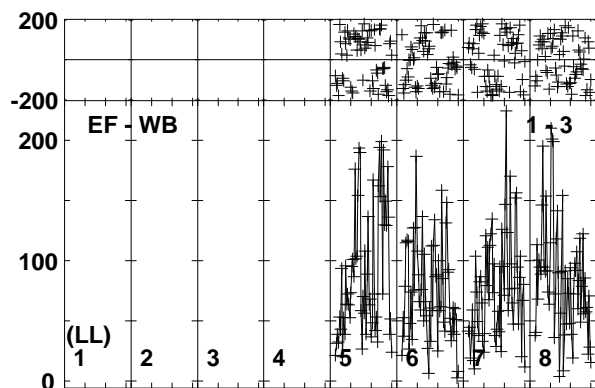
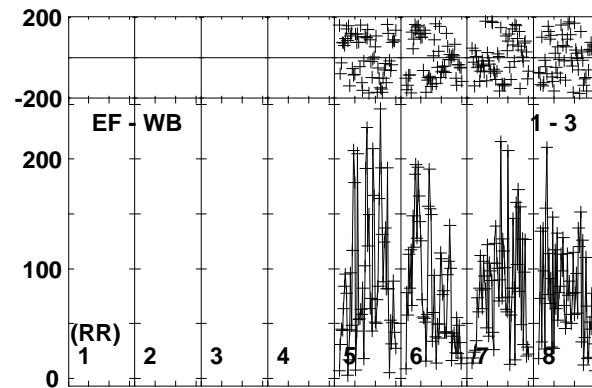
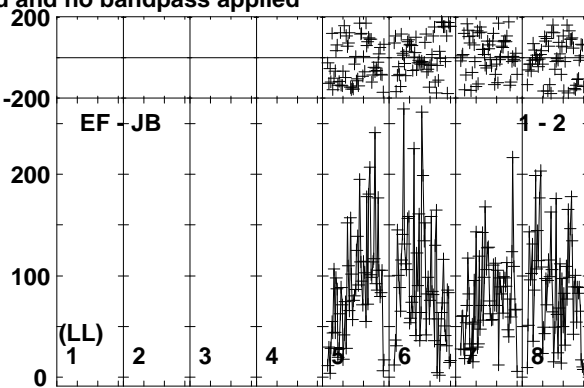
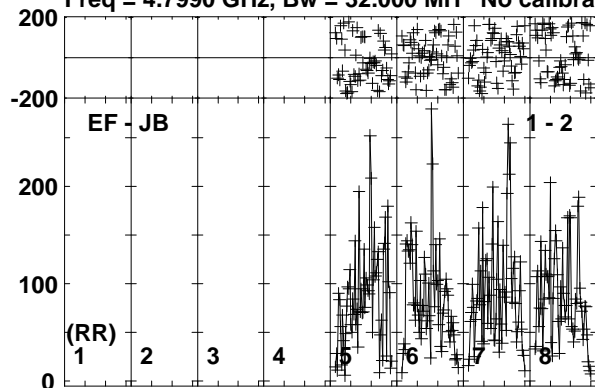

Lower frame: Micro Ampl Jy Top frame: Phas deg
Vector averaged cross-power spectrum Baseline: EF (01) - JB (02)
Timerange: 00/06:46:00 to 00/06:49:29

Plot file version 36 created 03-OCT-2017 13:27:19

ARUMA EG096C.UVDATA.1

Freq = 4.7990 GHz, Bw = 32.000 MH No calibration applied and no bandpass applied

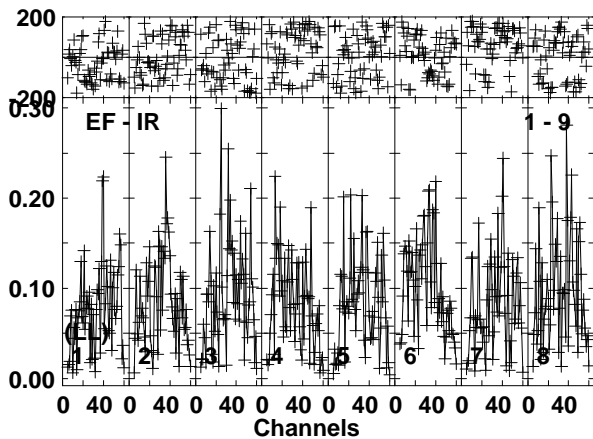
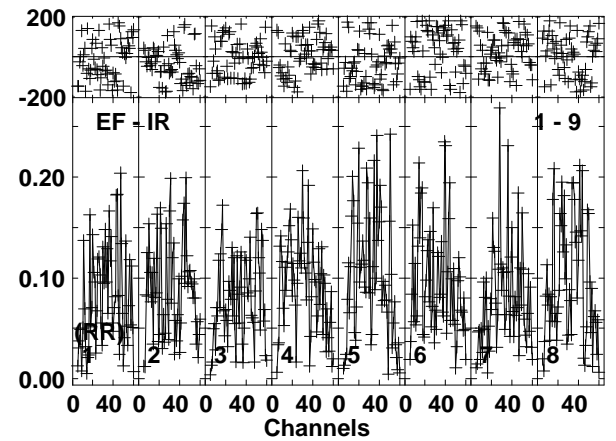
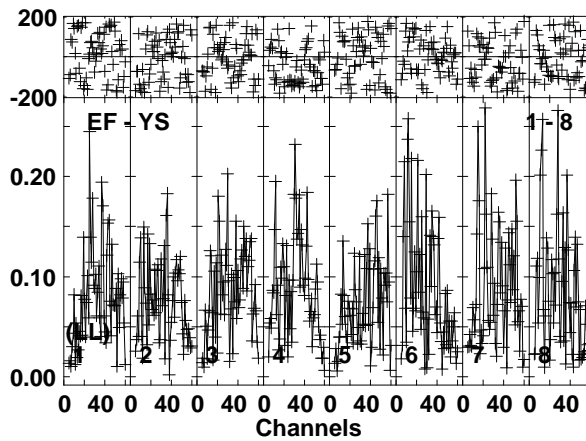
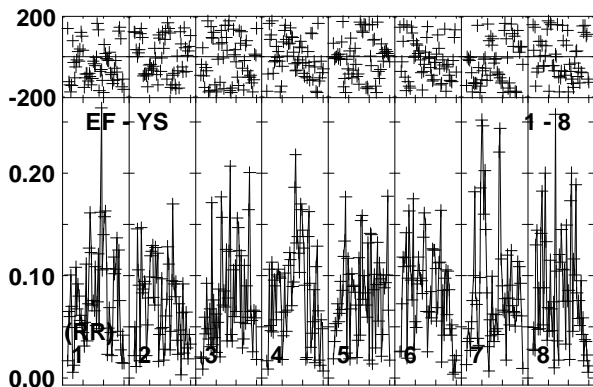
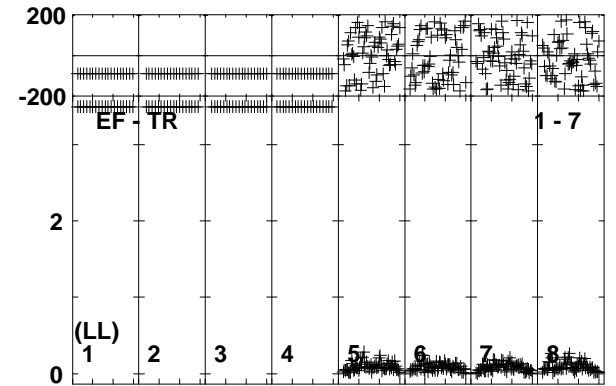
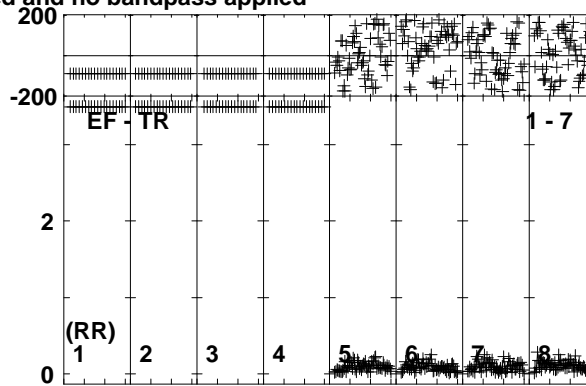
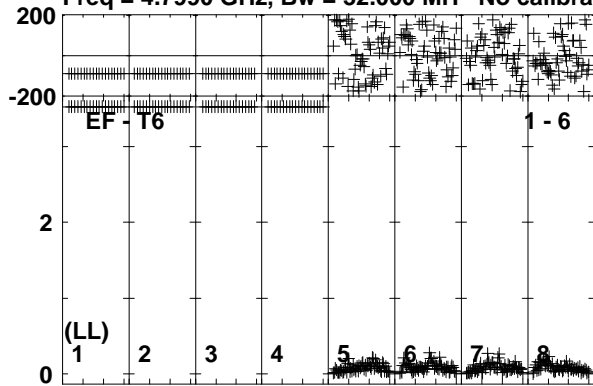

Lower frame: Milli Ampl Jy Top frame: Phas deg
Vector averaged cross-power spectrum Baseline: EF (01) - T6 (06)
Timerange: 00/06:46:00 to 00/06:49:29

Plot file version 37 created 03-OCT-2017 13:27:19

J1108+4330 EG096C.UVDATA.1

Freq = 4.7990 GHz, Bw = 32.000 MH No calibration applied and no bandpass applied

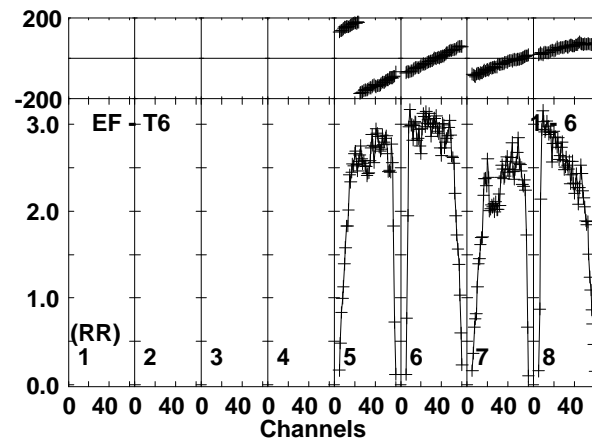
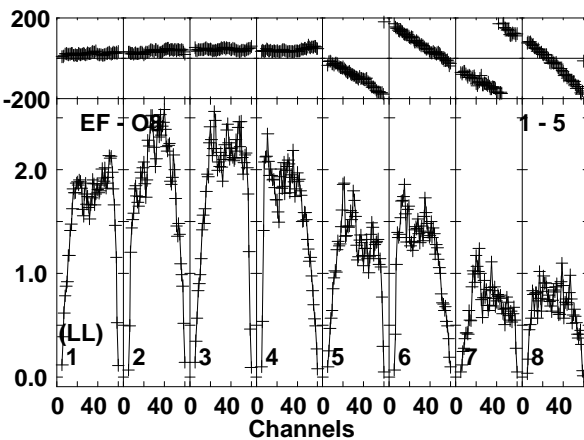
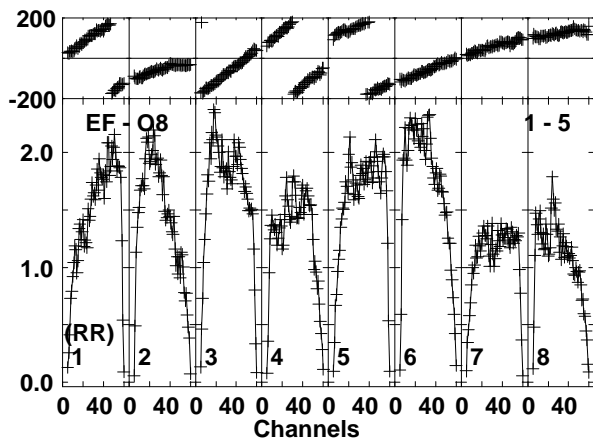
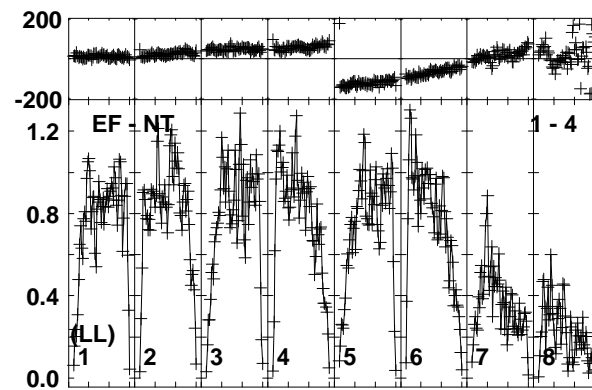
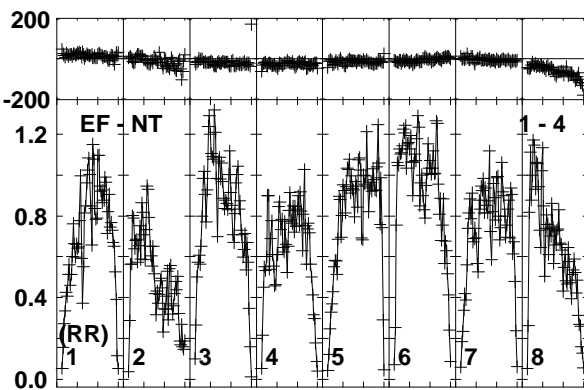
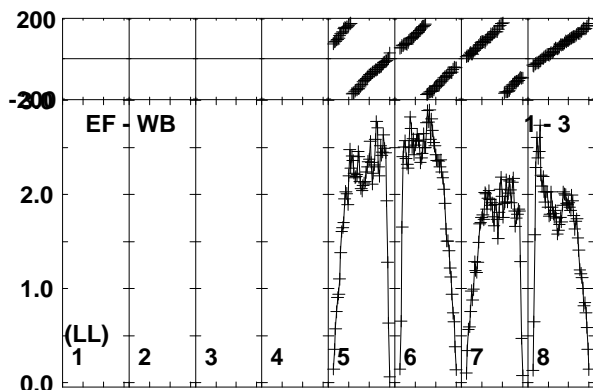
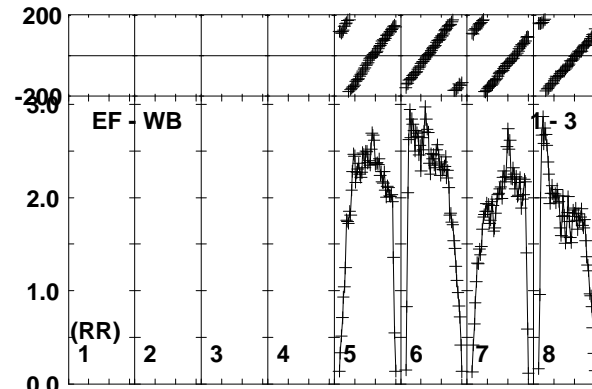
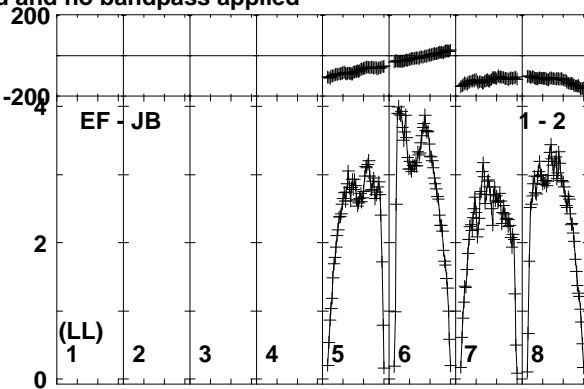
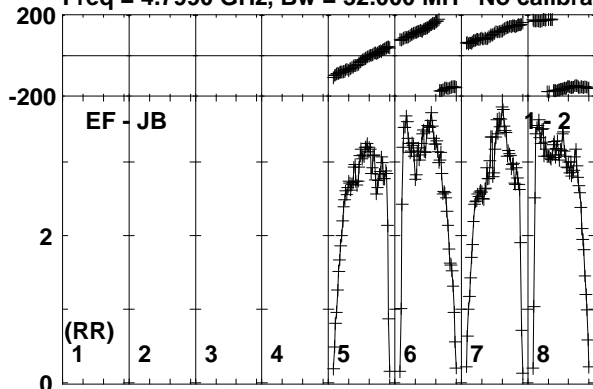

Lower frame: Milli Ampl Jy Top frame: Phas deg
Vector averaged cross-power spectrum Baseline: EF (01) - JB (02)
Timerange: 00/06:50:10 to 00/06:51:08

Plot file version 38 created 03-OCT-2017 13:27:19

J1108+4330 EG096C.UVDATA.1

Freq = 4.7990 GHz, Bw = 32.000 MH No calibration applied and no bandpass applied

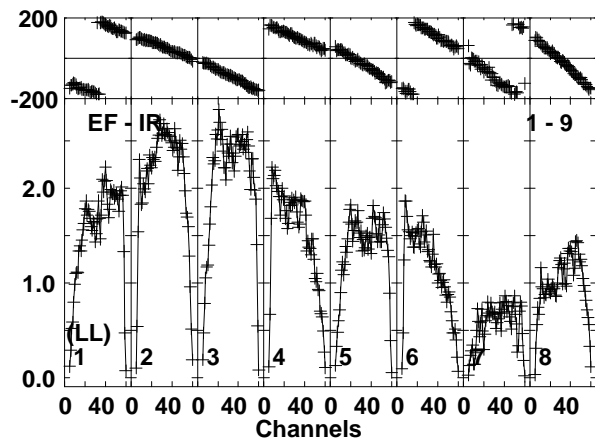
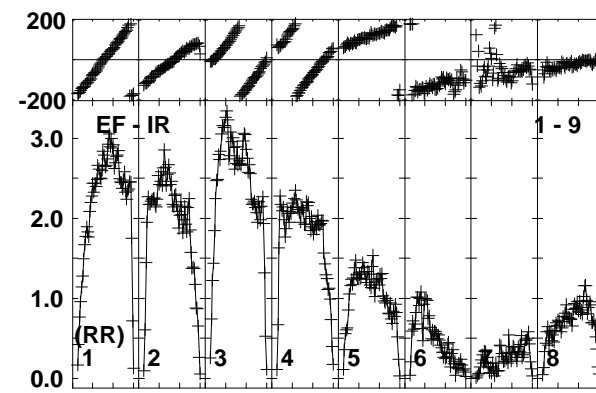
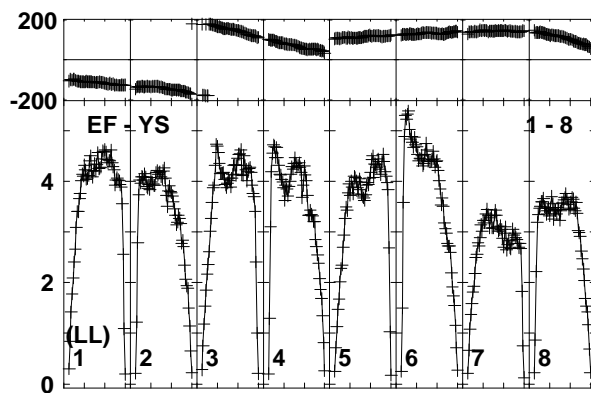
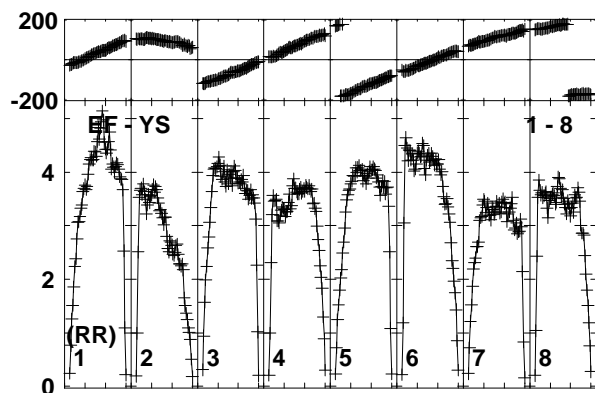
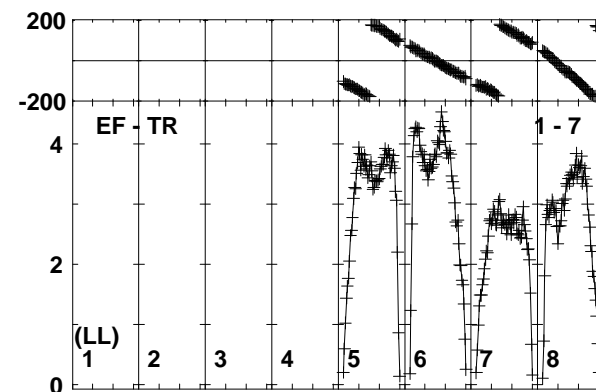
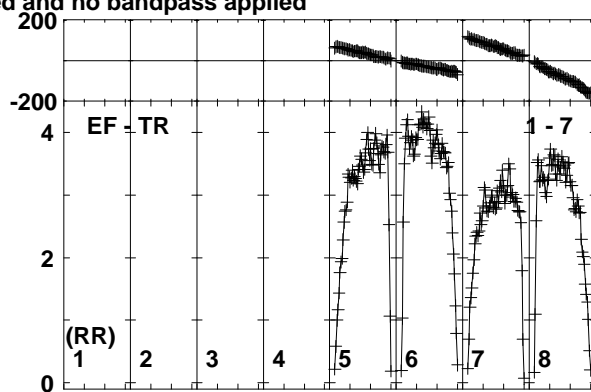
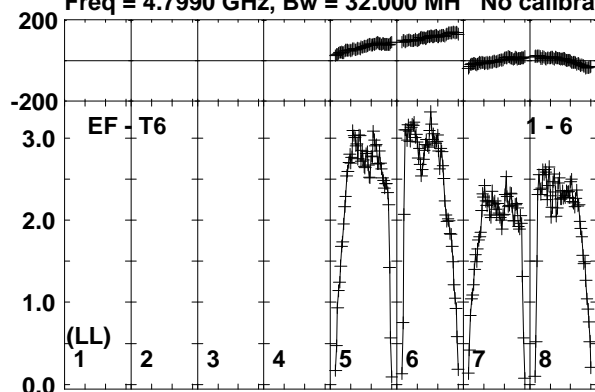

Lower frame: Milli Ampl Jy Top frame: Phas deg
Vector averaged cross-power spectrum Baseline: EF (01) - T6 (06)
Timerange: 00/06:50:10 to 00/06:51:08

Plot file version 39 created 03-OCT-2017 13:27:20

ARUMA EG096C.UVDATA.1

Freq = 4.7990 GHz, Bw = 32.000 MH No calibration applied and no bandpass applied

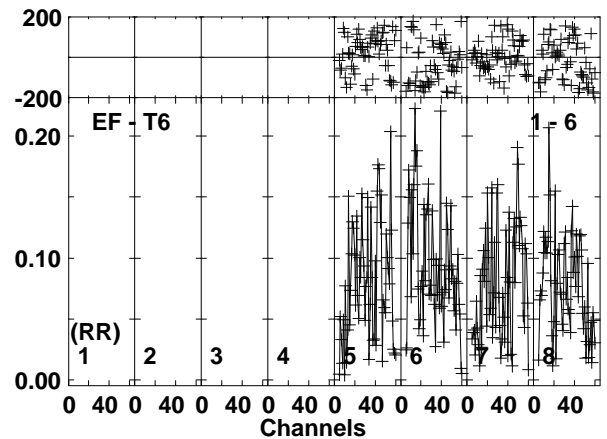
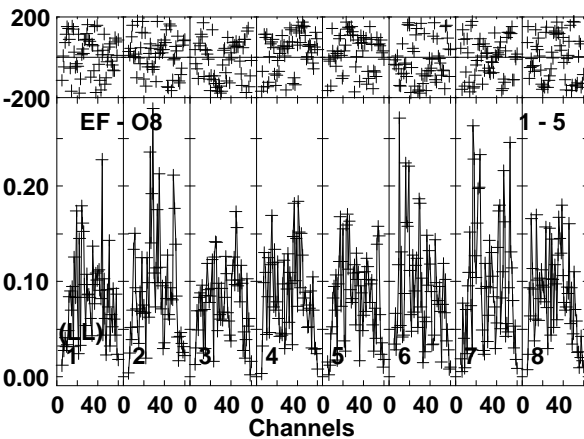
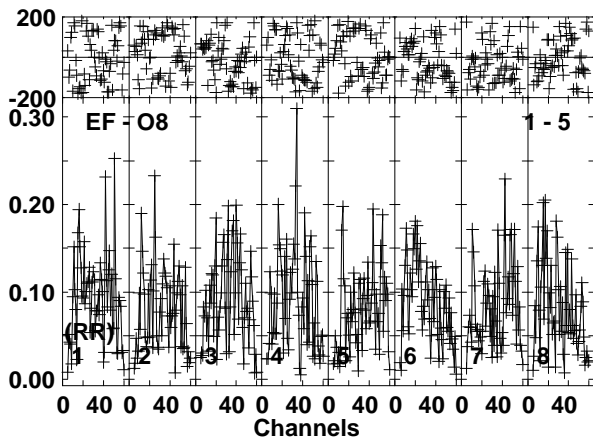
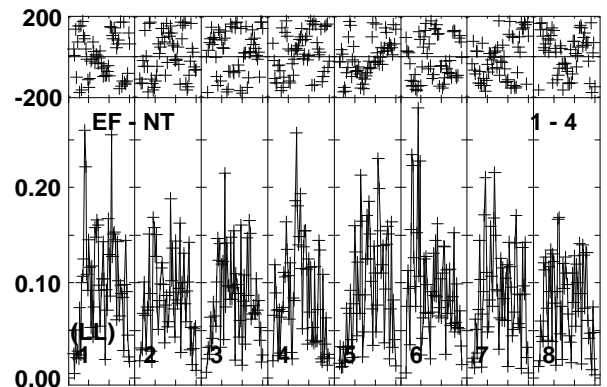
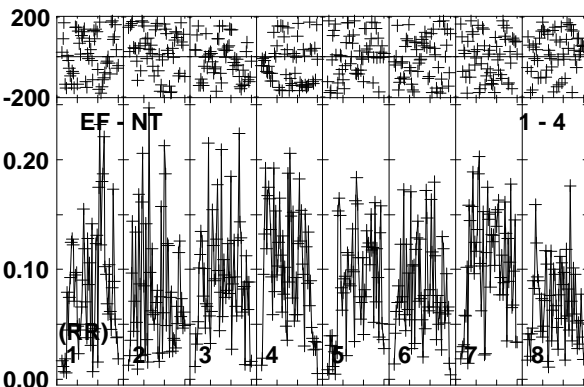
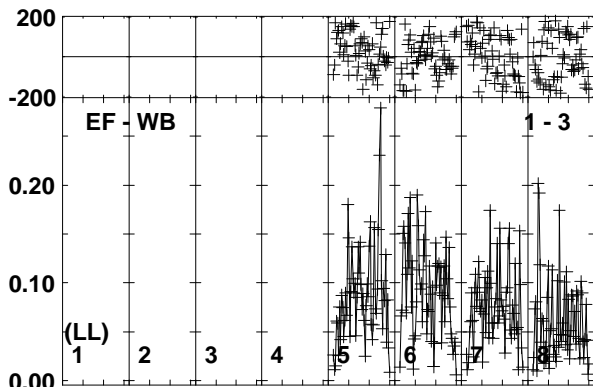
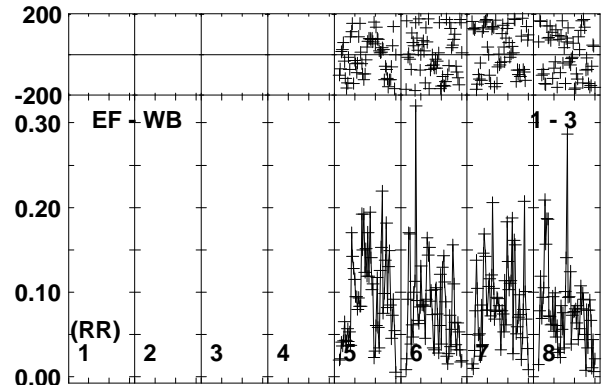
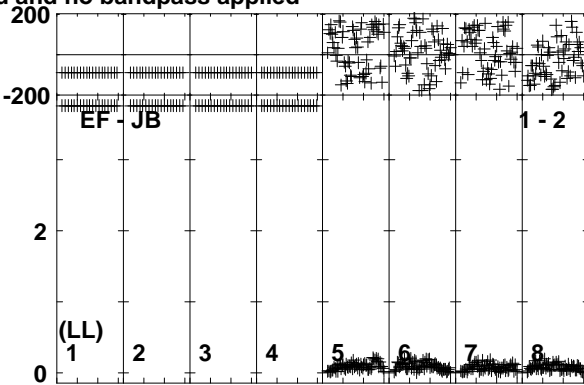
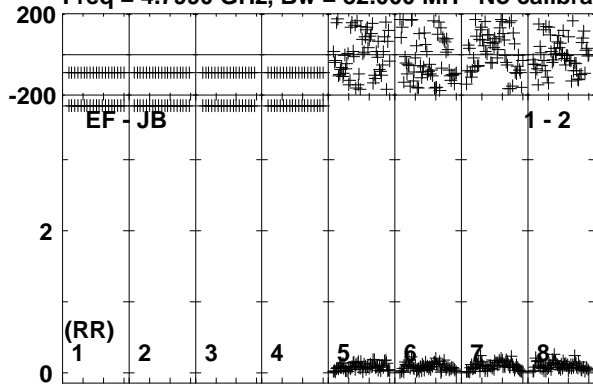

Lower frame: Milli Ampl Jy Top frame: Phas deg
Vector averaged cross-power spectrum Baseline: EF (01) - JB (02)
Timerange: 00/06:51:10 to 00/06:54:39

Plot file version 40 created 03-OCT-2017 13:27:20

ARUMA EG096C.UVDATA.1

Freq = 4.7990 GHz, Bw = 32.000 MH No calibration applied and no bandpass applied

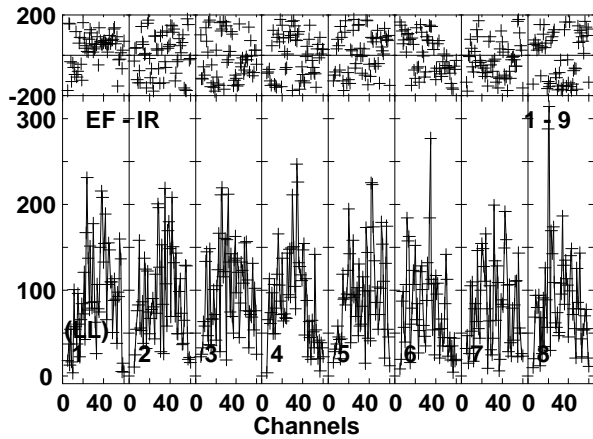
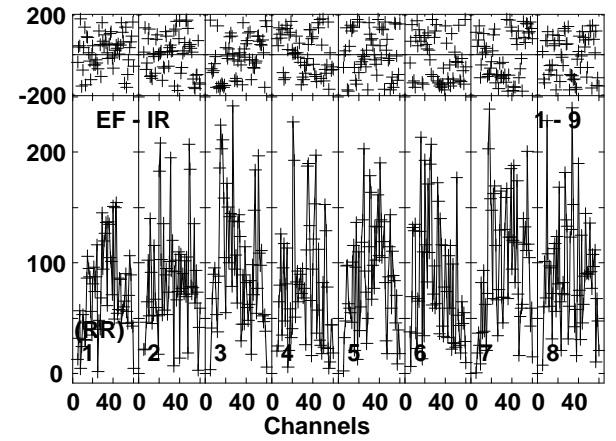
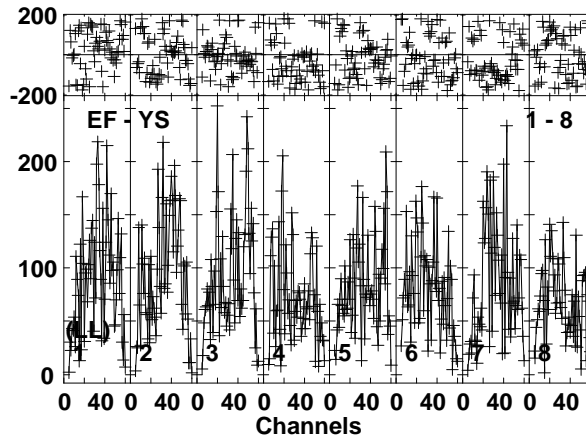
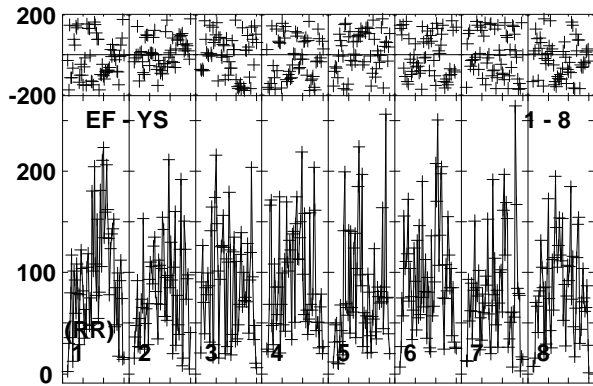
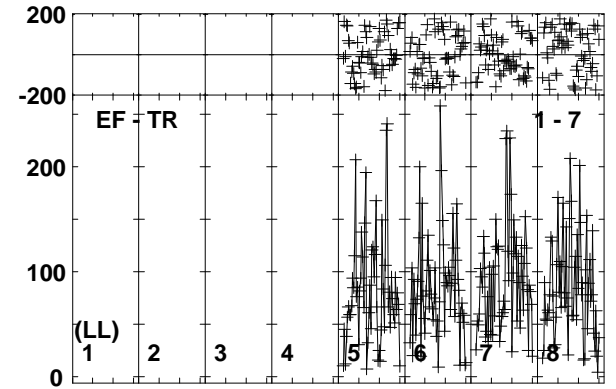
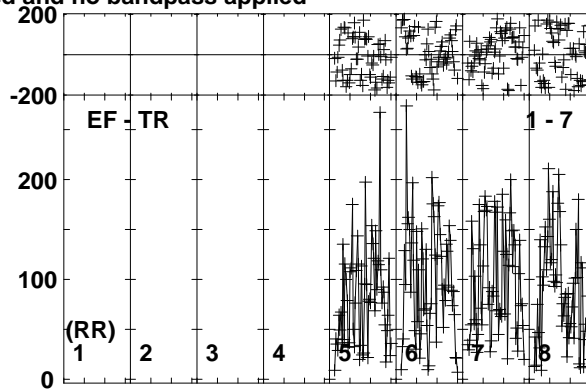
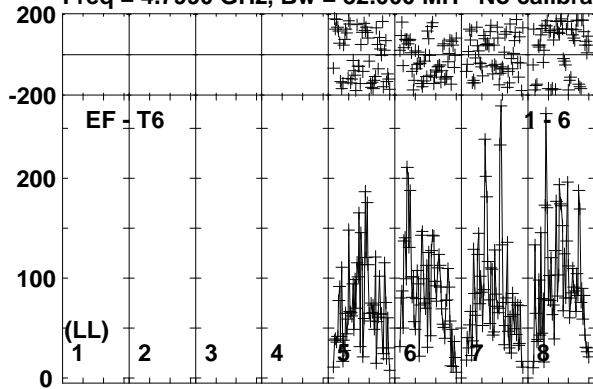

Lower frame: Micro Ampl Jy Top frame: Phas deg
Vector averaged cross-power spectrum Baseline: EF (01) - T6 (06)
Timerange: 00/06:51:10 to 00/06:54:39

Plot file version 41 created 03-OCT-2017 13:27:20

J1108+4330 EG096C.UVDATA.1

Freq = 4.7990 GHz, Bw = 32.000 MH No calibration applied and no bandpass applied

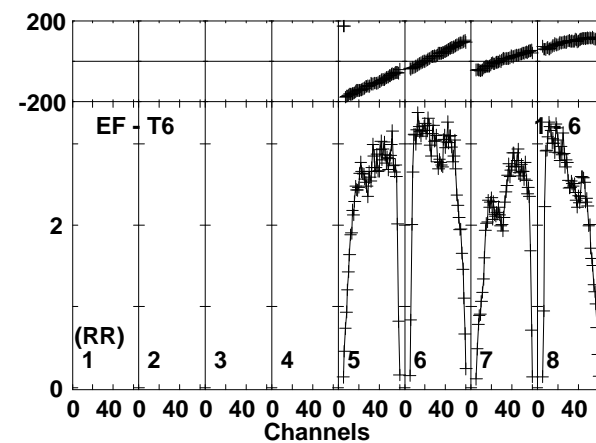
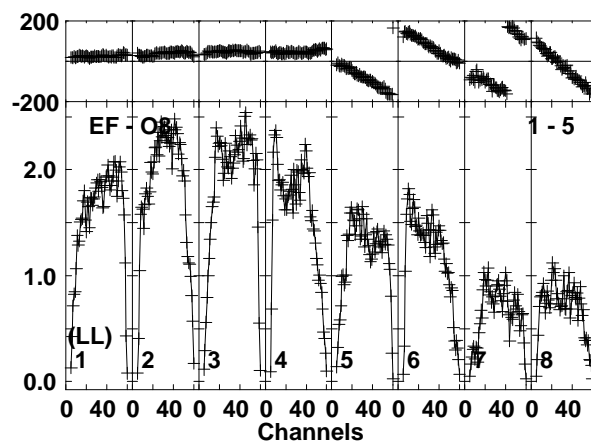
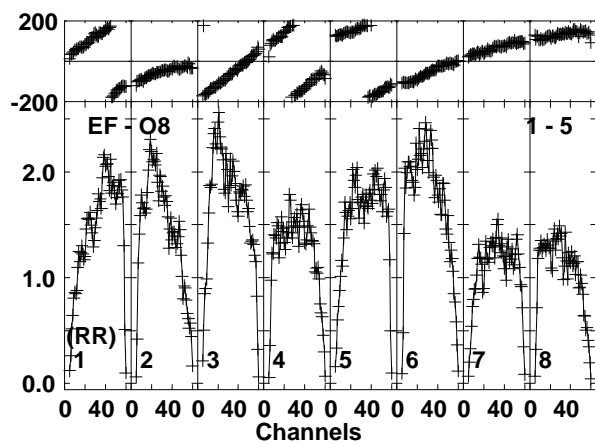
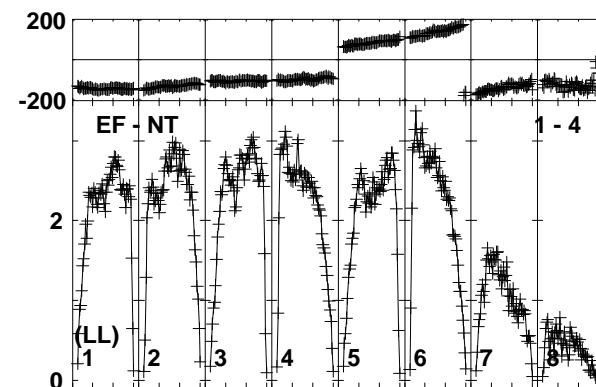
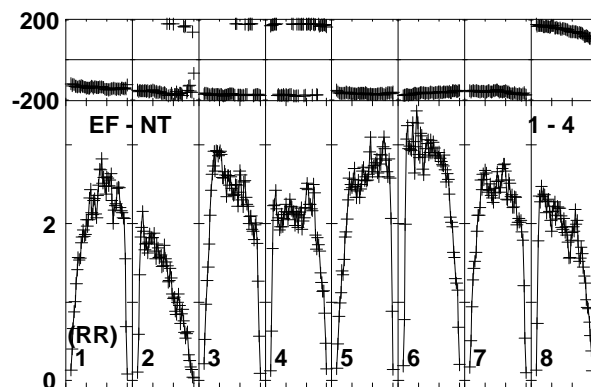
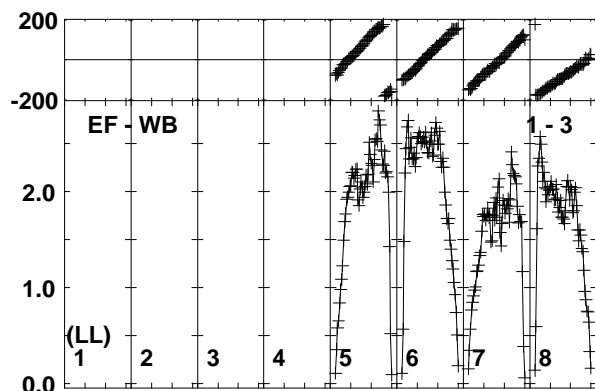
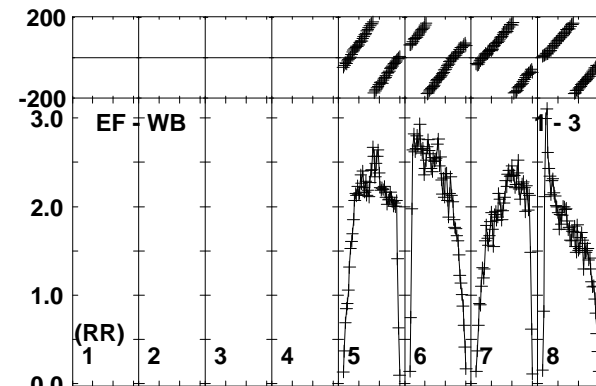
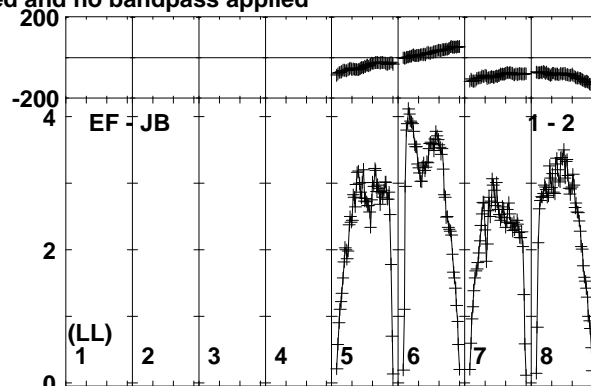
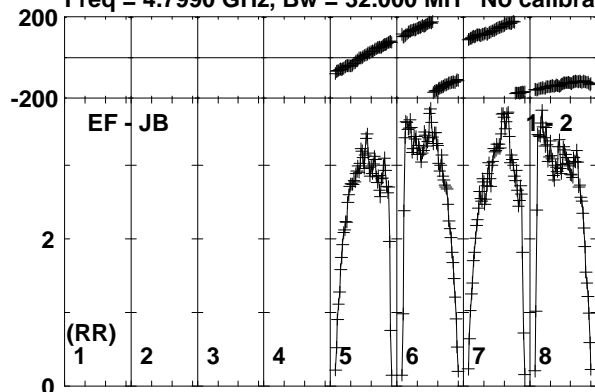

Lower frame: Milli Ampl Jy Top frame: Phas deg
Vector averaged cross-power spectrum Baseline: EF (01) - JB (02)
Timerange: 00/06:54:40 to 00/06:56:09

Plot file version 42 created 03-OCT-2017 13:27:20

J1108+4330 EG096C.UVDATA.1

Freq = 4.7990 GHz, Bw = 32.000 MH No calibration applied and no bandpass applied

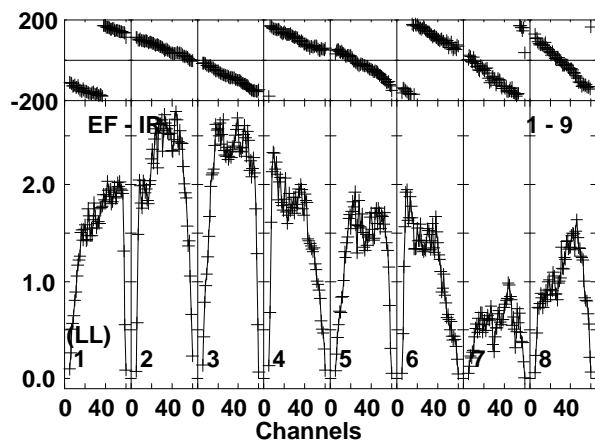
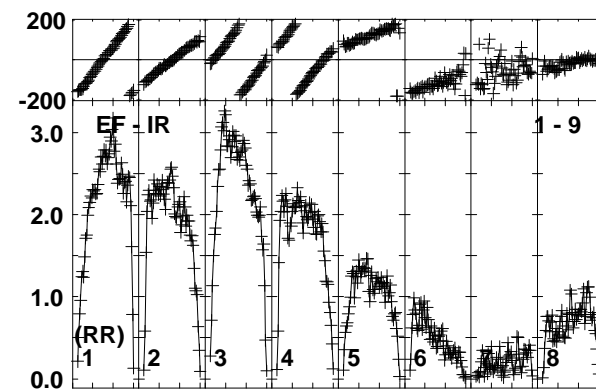
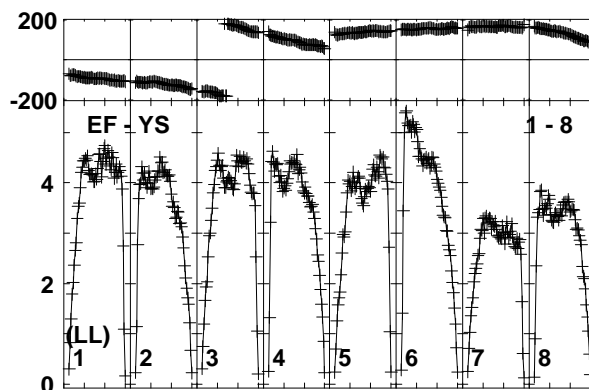
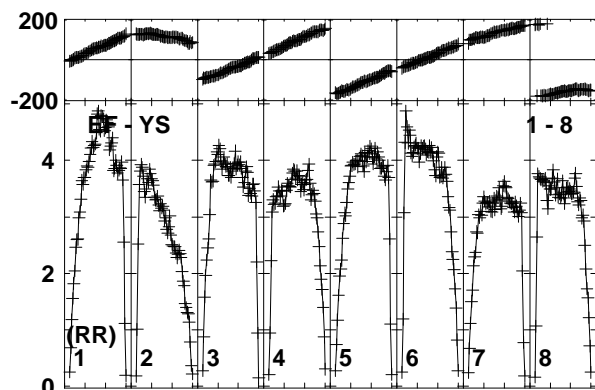
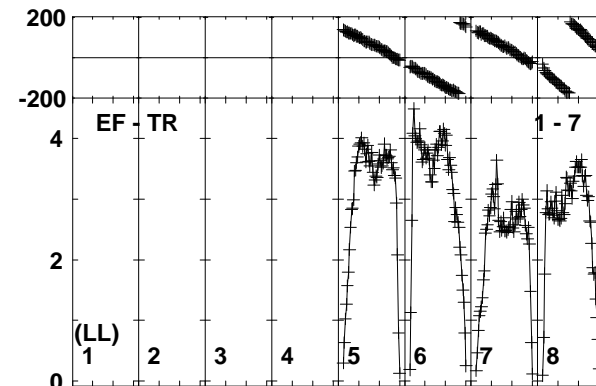
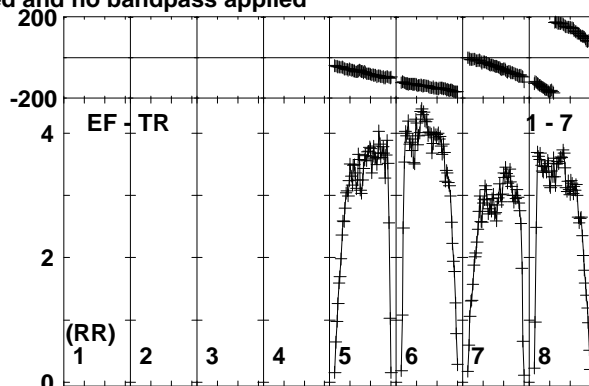
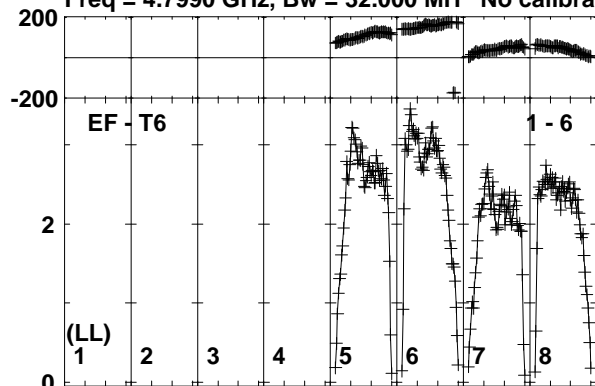

Lower frame: Milli Ampl Jy Top frame: Phas deg
Vector averaged cross-power spectrum Baseline: EF (01) - T6 (06)
Timerange: 00/06:54:40 to 00/06:56:09

Plot file version 43 created 03-OCT-2017 13:27:21

ARUMA EG096C.UVDATA.1

Freq = 4.7990 GHz, Bw = 32.000 MH No calibration applied and no bandpass applied

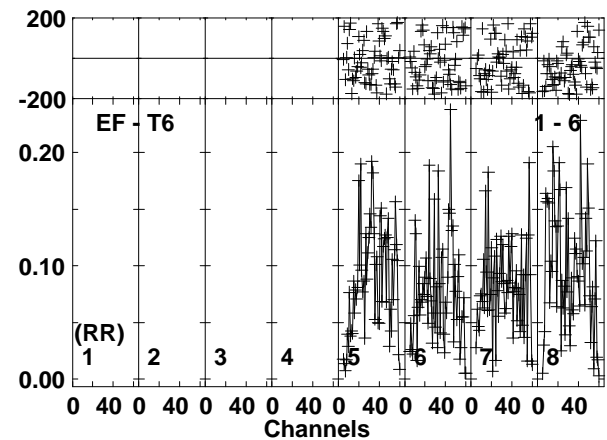
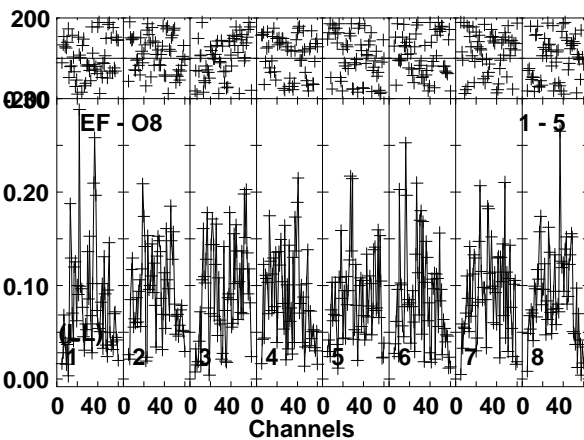
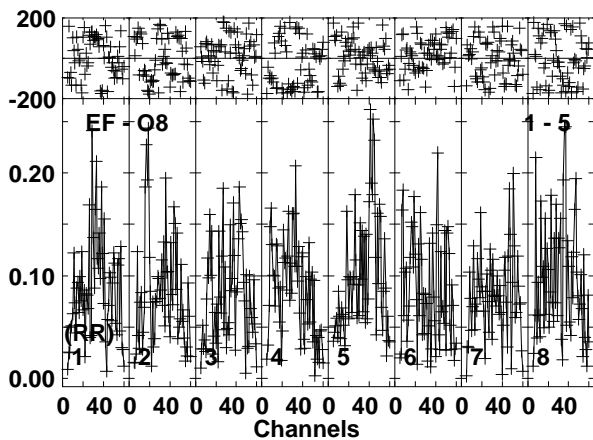
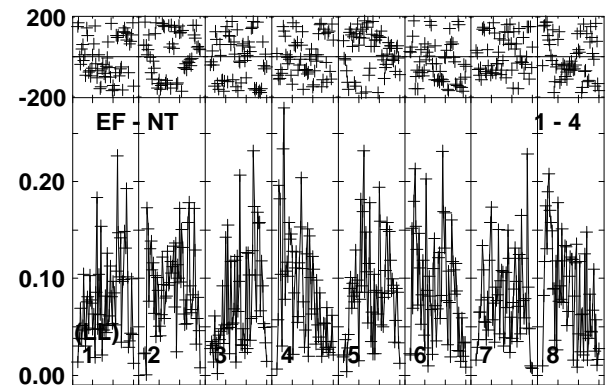
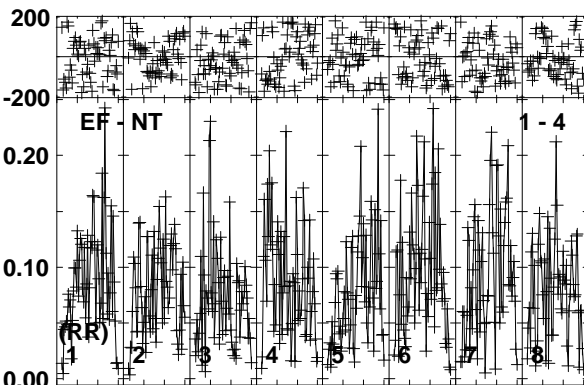
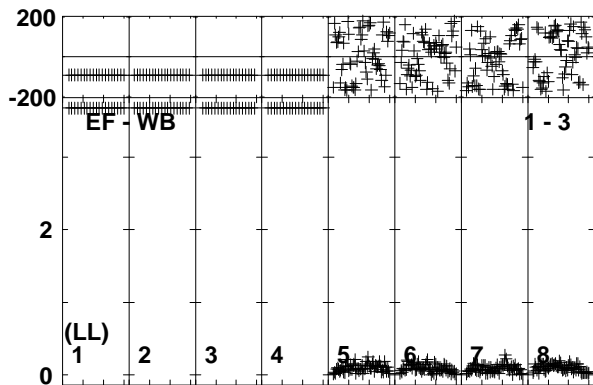
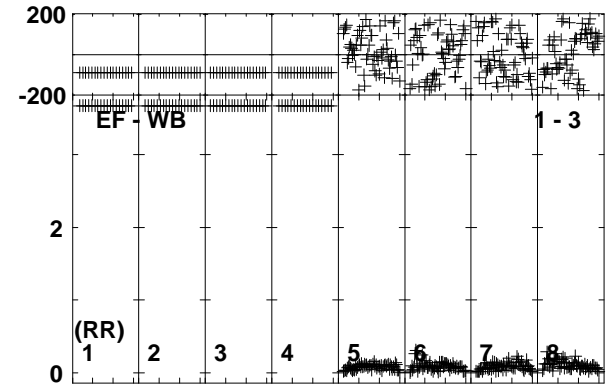
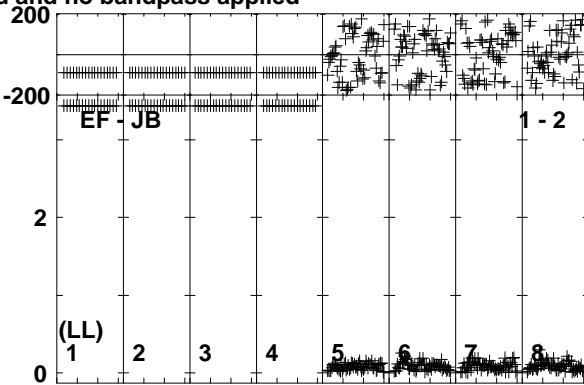
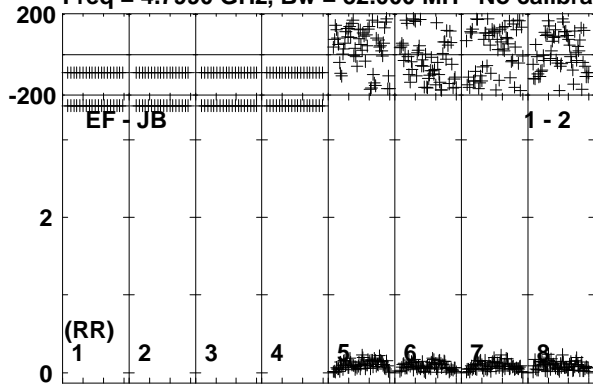

Lower frame: Milli Ampl Jy Top frame: Phas deg
Vector averaged cross-power spectrum Baseline: EF (01) - JB (02)
Timerange: 00/06:56:09 to 00/06:59:39

Plot file version 44 created 03-OCT-2017 13:27:21

ARUMA EG096C.UVDATA.1

Freq = 4.7990 GHz, Bw = 32.000 MH No calibration applied and no bandpass applied

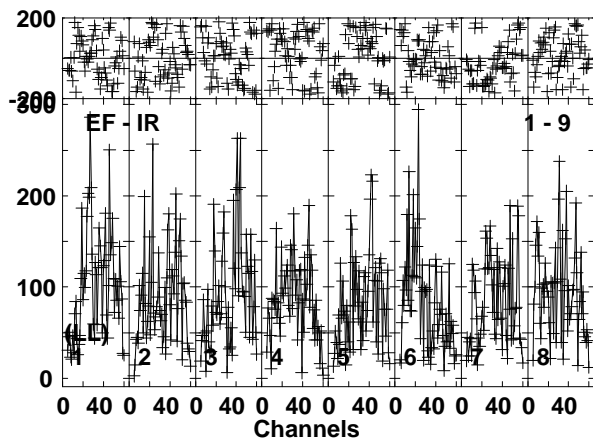
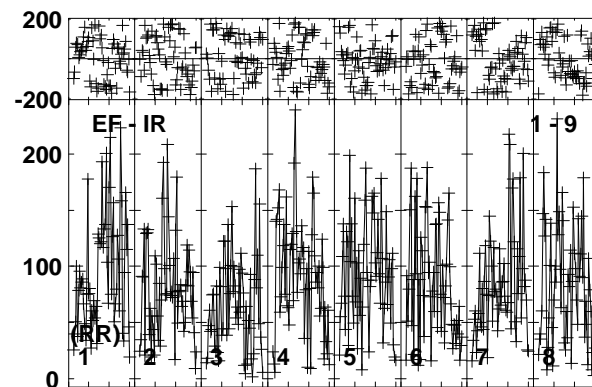
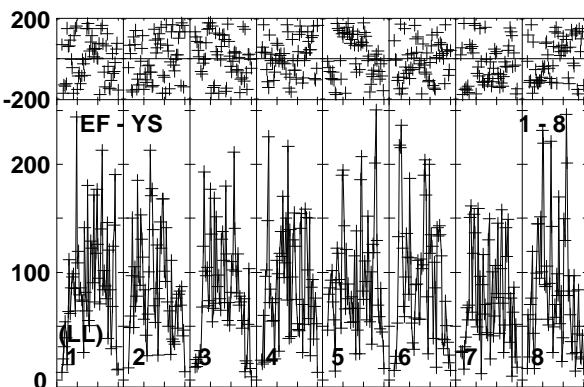
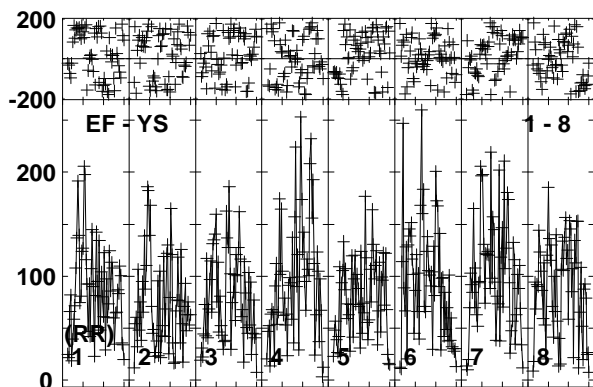
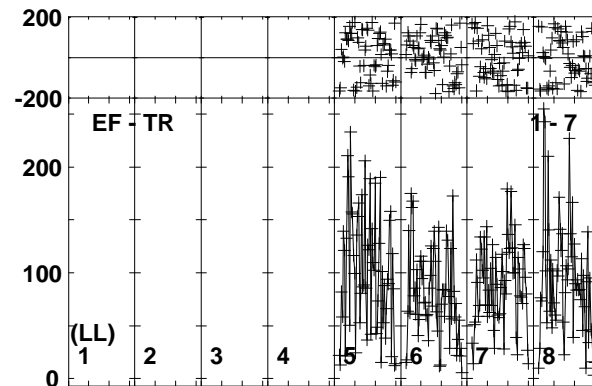
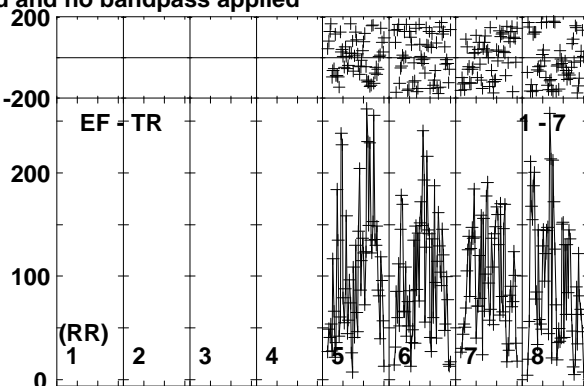
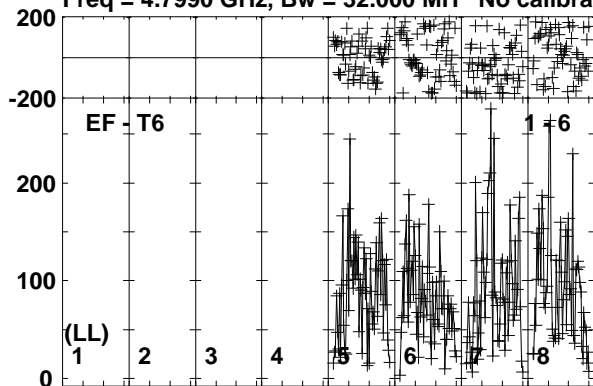

Lower frame: Micro Ampl Jy Top frame: Phas deg
Vector averaged cross-power spectrum Baseline: EF (01) - T6 (06)
Timerange: 00/06:56:09 to 00/06:59:39

Plot file version 45 created 03-OCT-2017 13:27:21

J1108+4330 EG096C.UVDATA.1

Freq = 4.7990 GHz, Bw = 32.000 MH No calibration applied and no bandpass applied

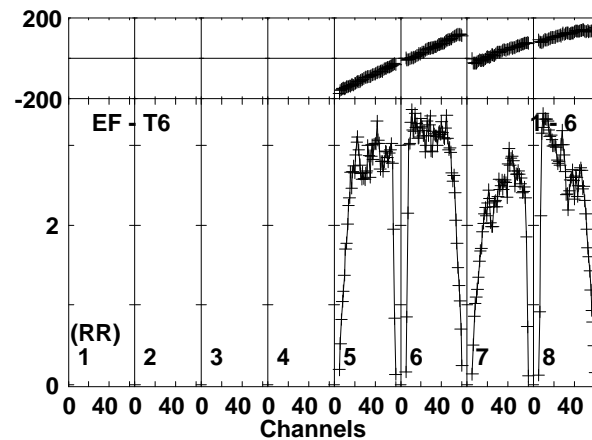
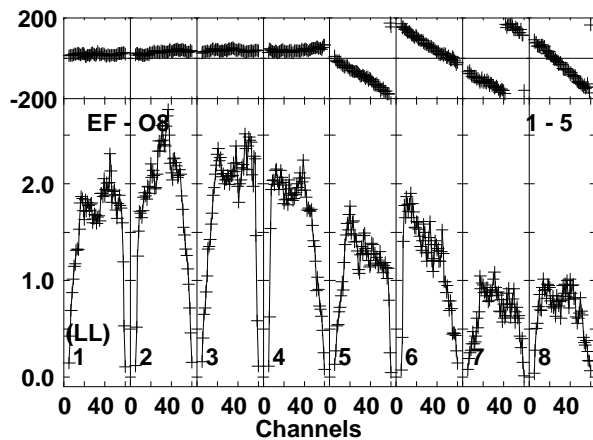
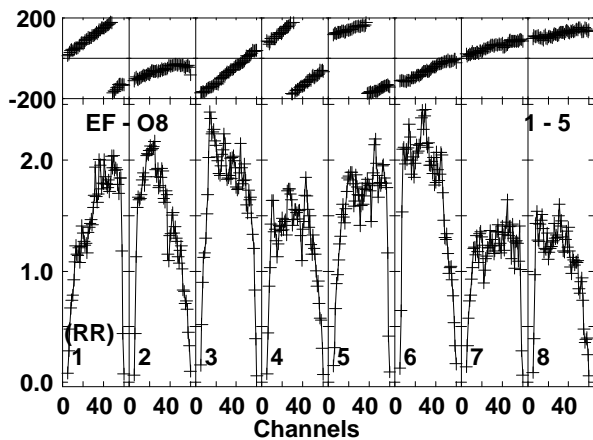
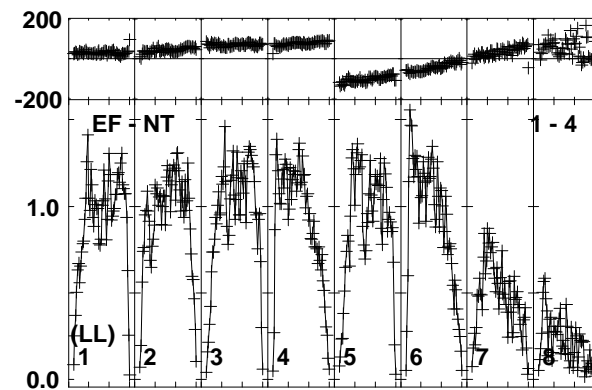
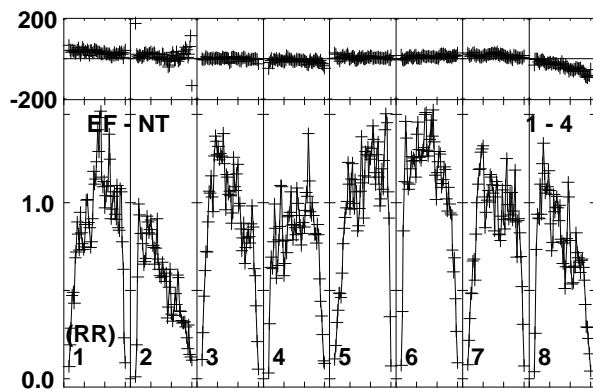
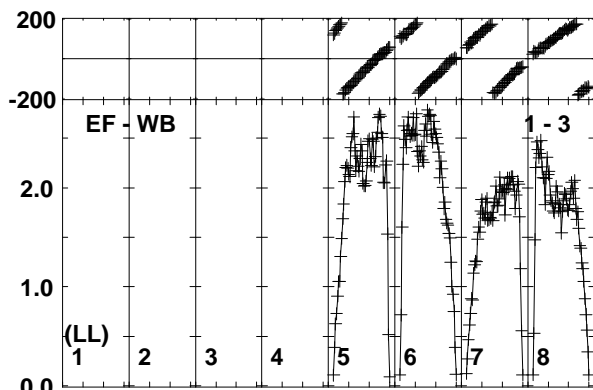
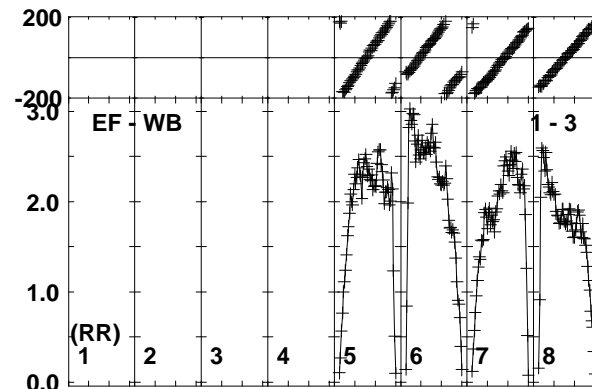
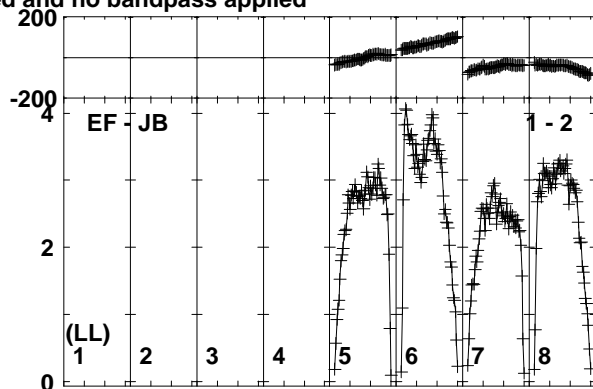
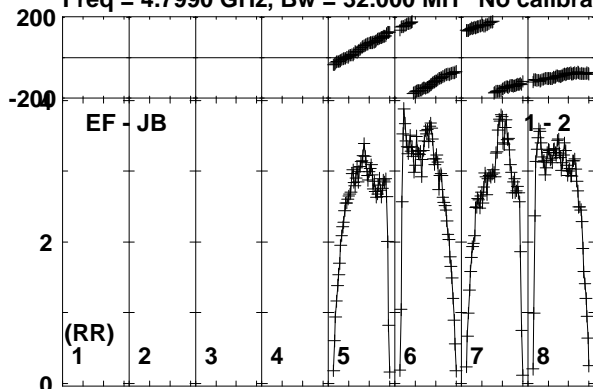

Lower frame: Milli Ampl Jy Top frame: Phas deg
Vector averaged cross-power spectrum Baseline: EF (01) - JB (02)
Timerange: 00/07:00:19 to 00/07:01:19

Plot file version 46 created 03-OCT-2017 13:27:21

J1108+4330 EG096C.UVDATA.1

Freq = 4.7990 GHz, Bw = 32.000 MH No calibration applied and no bandpass applied

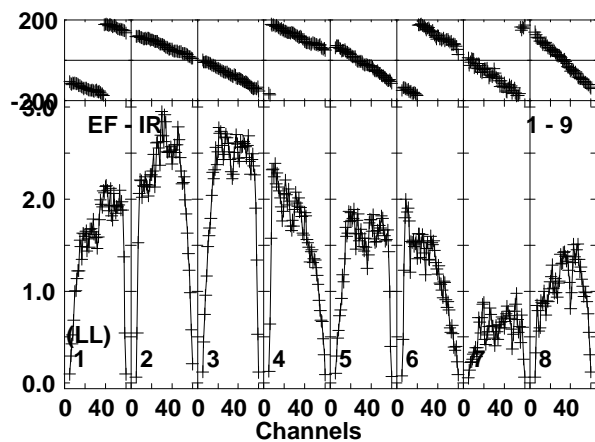
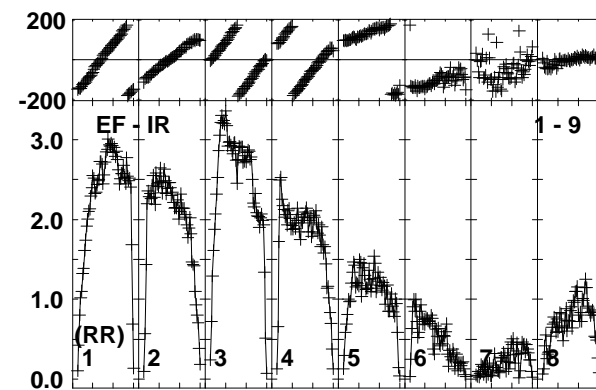
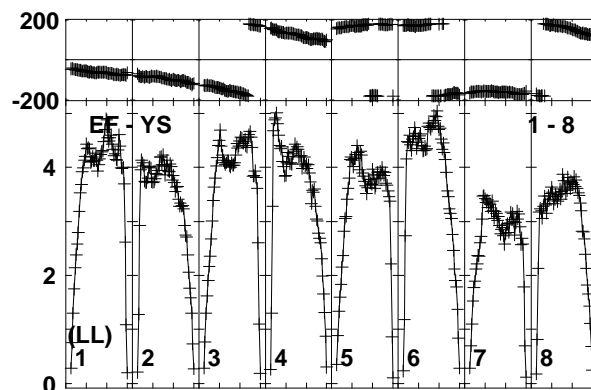
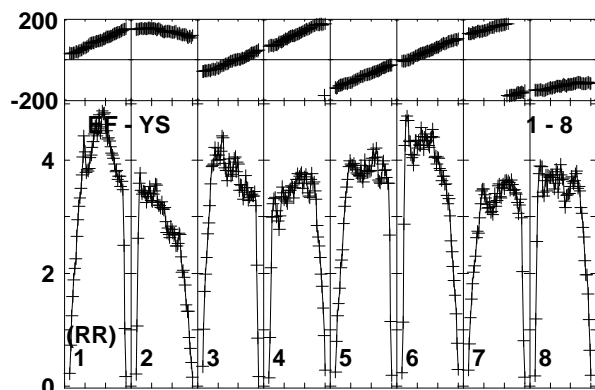
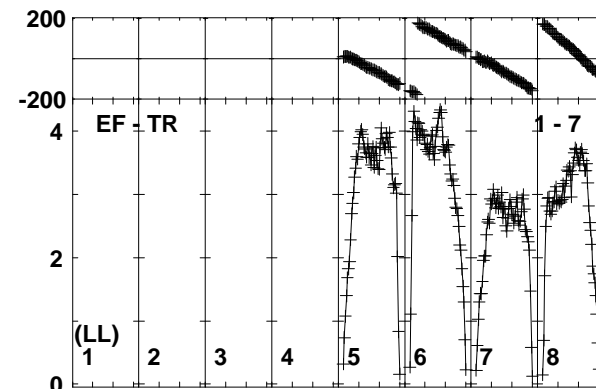
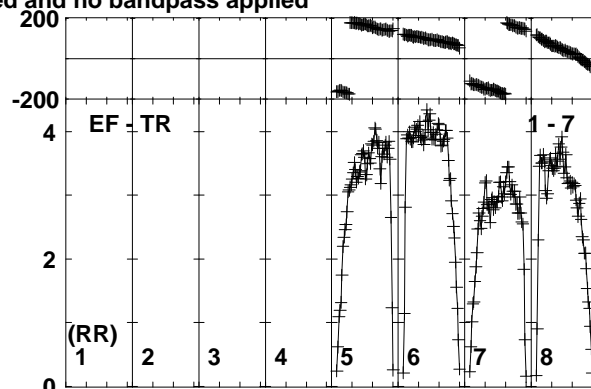
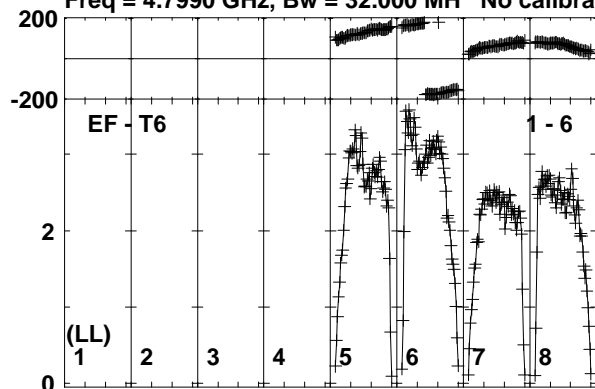

Lower frame: Milli Ampl Jy Top frame: Phas deg
Vector averaged cross-power spectrum Baseline: EF (01) - T6 (06)
Timerange: 00/07:00:19 to 00/07:01:19

Plot file version 47 created 03-OCT-2017 13:27:22
 ARUMA EG096C.UVDATA.1
 Freq = 4.7990 GHz, Bw = 32.000 MH No calibration applied and no bandpass applied

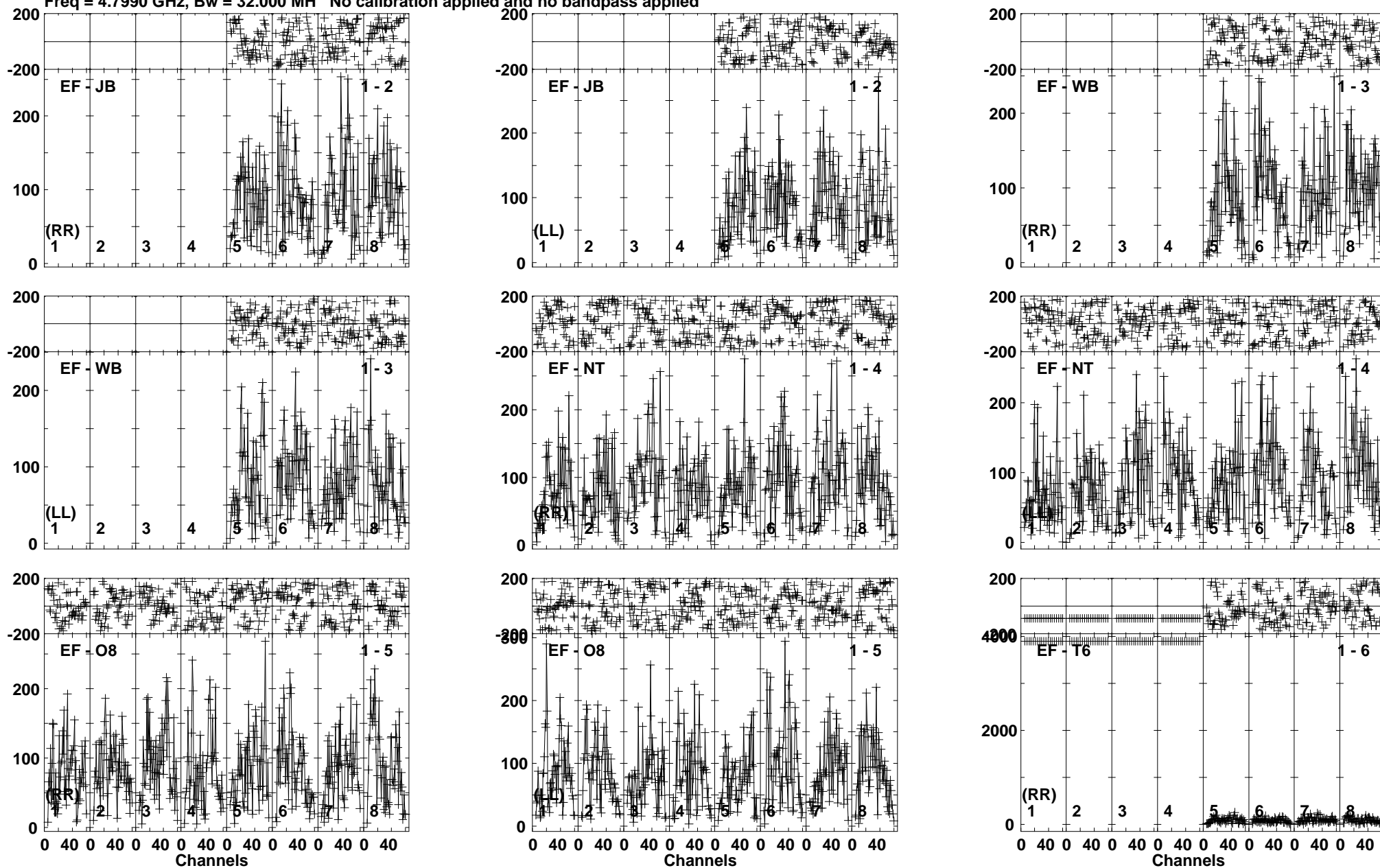

Lower frame: Micro Ampl Jy Top frame: Phas deg
 Vector averaged cross-power spectrum Baseline: EF (01) - JB (02)
 Timerange: 00/07:01:19 to 00/07:04:49

Plot file version 48 created 03-OCT-2017 13:27:22

ARUMA EG096C.UVDATA.1

Freq = 4.7990 GHz, Bw = 32.000 MH No calibration applied and no bandpass applied

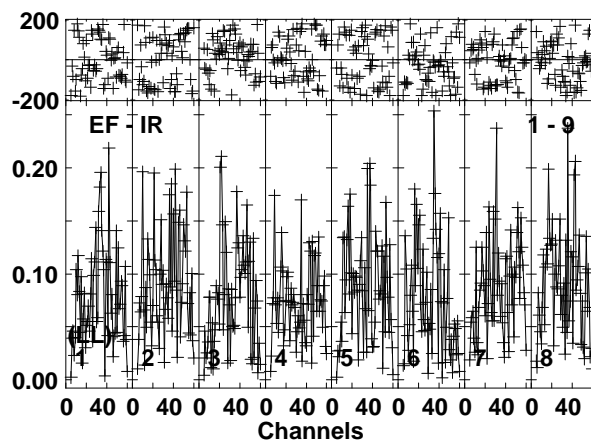
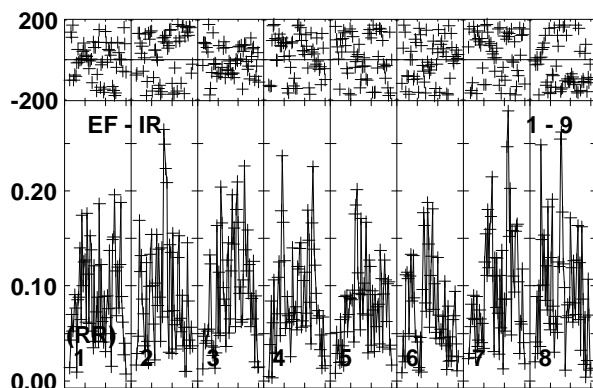
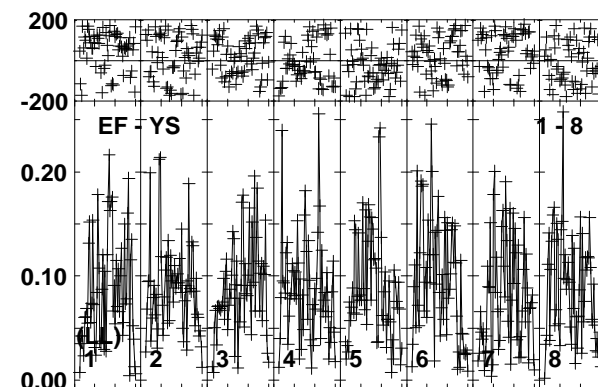
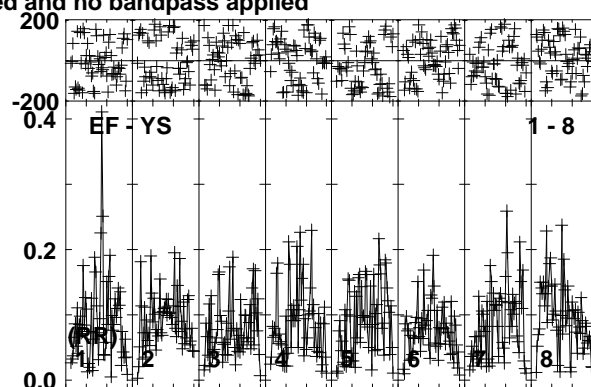
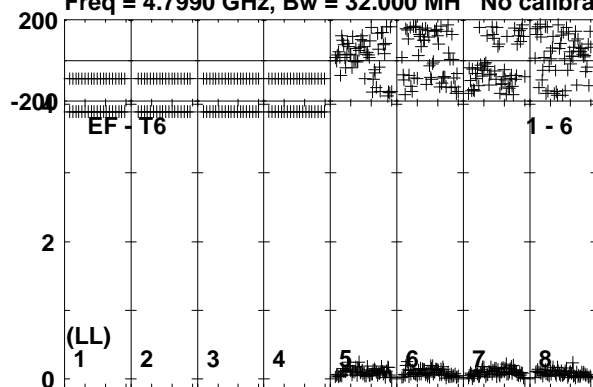

Lower frame: Milli Ampl Jy Top frame: Phas deg
Vector averaged cross-power spectrum Baseline: EF (01) - T6 (06)
Timerange: 00/07:01:19 to 00/07:04:49

Plot file version 49 created 03-OCT-2017 13:27:22

J1108+4330 EG096C.UVDATA.1

Freq = 4.7990 GHz, Bw = 32.000 MH No calibration applied and no bandpass applied

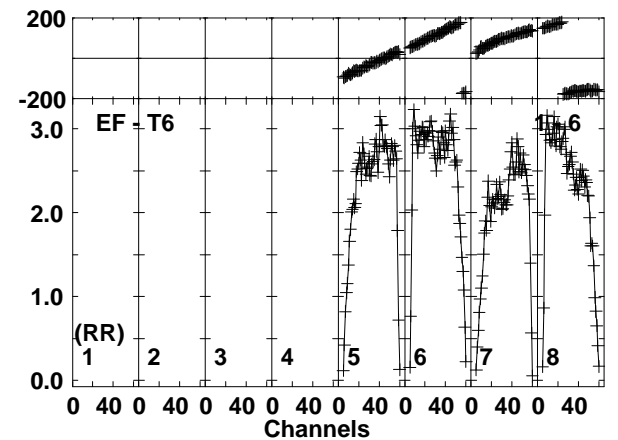
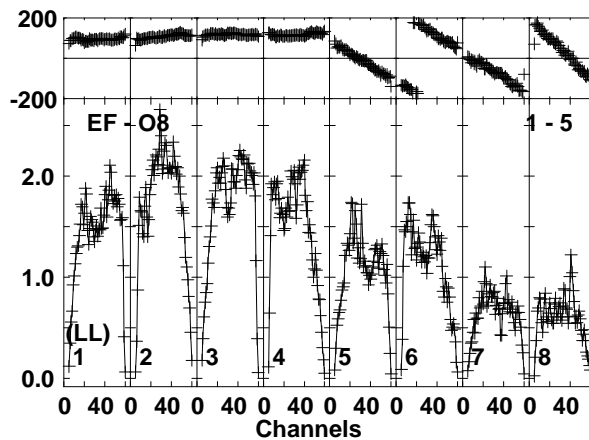
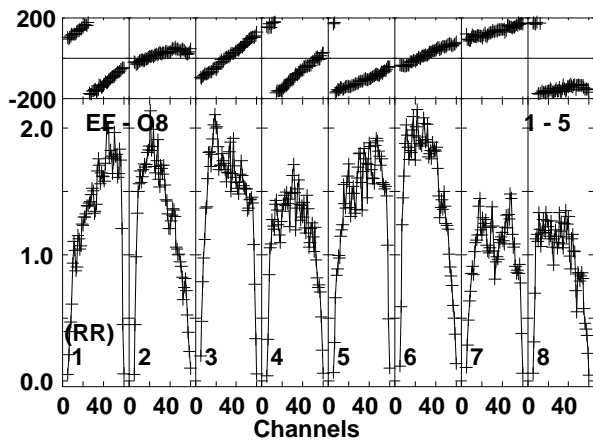
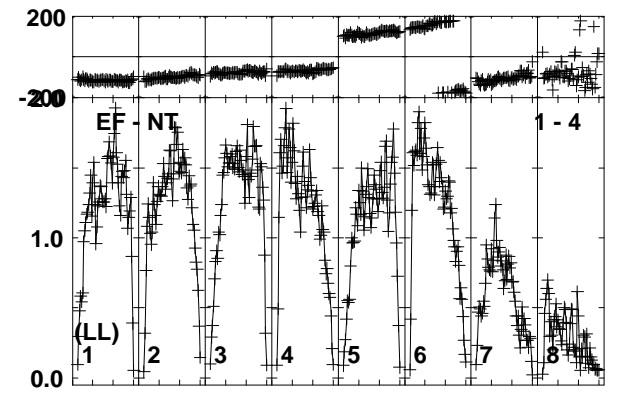
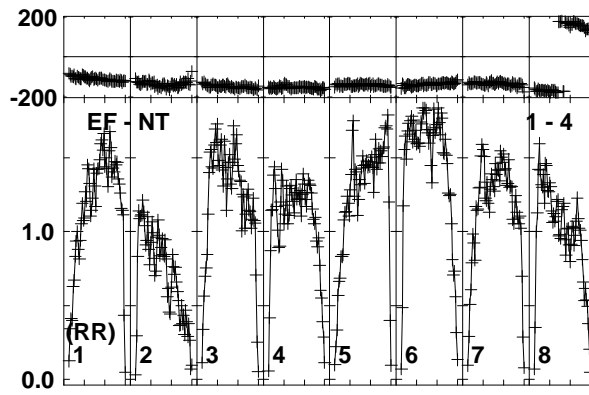
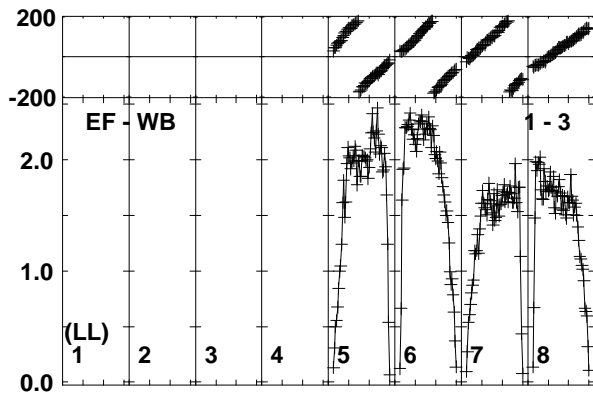
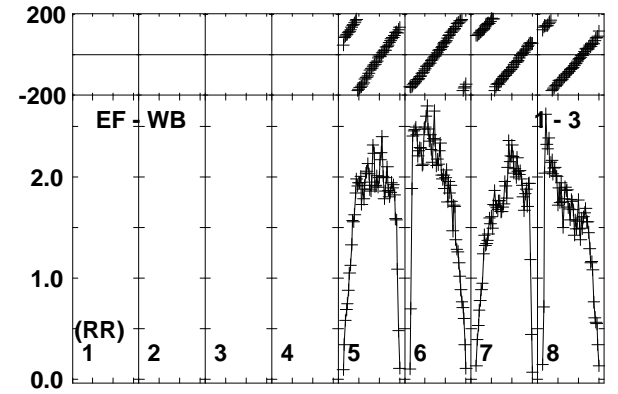
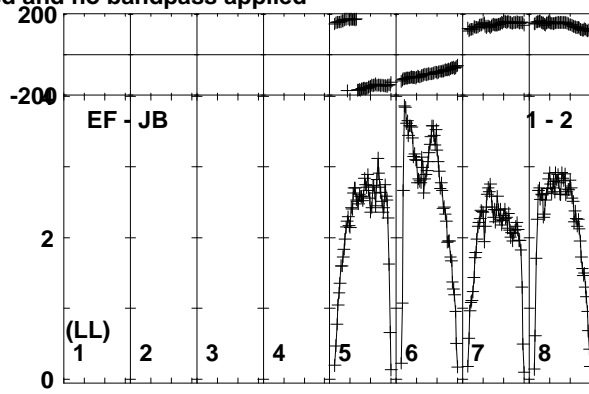
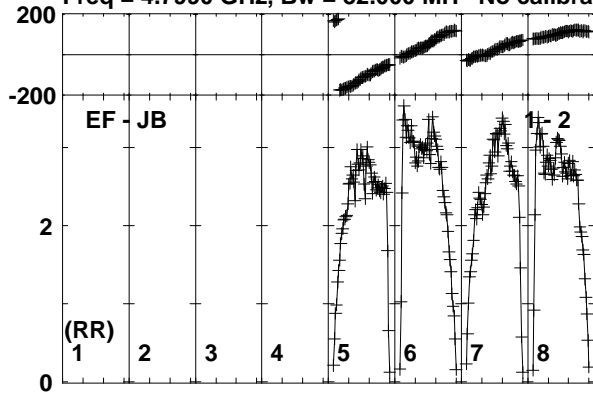

Lower frame: Milli Ampl Jy Top frame: Phas deg
Vector averaged cross-power spectrum Baseline: EF (01) - JB (02)
Timerange: 00/07:04:50 to 00/07:06:18

Plot file version 50 created 03-OCT-2017 13:27:22

J1108+4330 EG096C.UVDATA.1

Freq = 4.7990 GHz, Bw = 32.000 MH No calibration applied and no bandpass applied

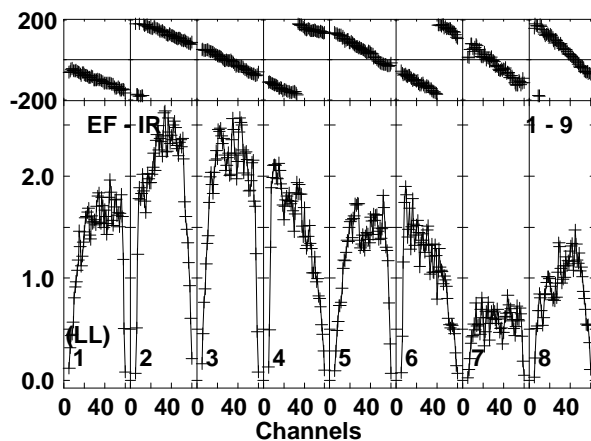
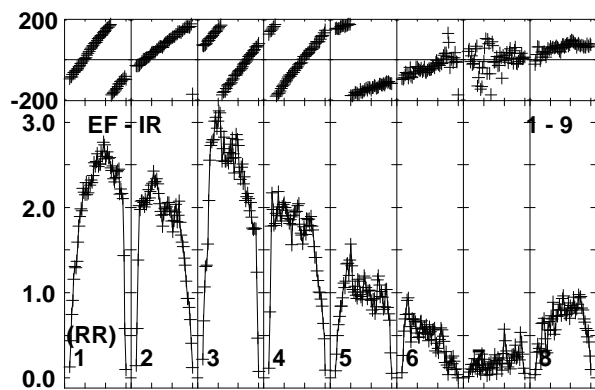
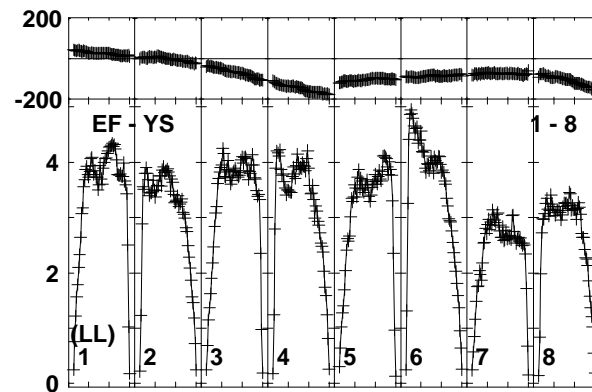
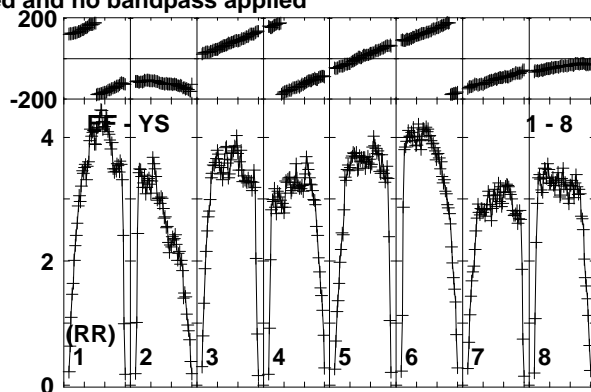
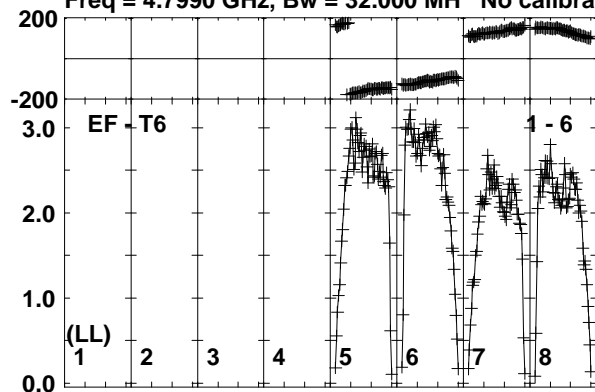

Lower frame: Milli Ampl Jy Top frame: Phas deg
Vector averaged cross-power spectrum Baseline: EF (01) - T6 (06)
Timerange: 00/07:04:50 to 00/07:06:18

Plot file version 51 created 03-OCT-2017 13:27:23

ARUMA EG096C.UVDATA.1

Freq = 4.7990 GHz, Bw = 32.000 MH No calibration applied and no bandpass applied

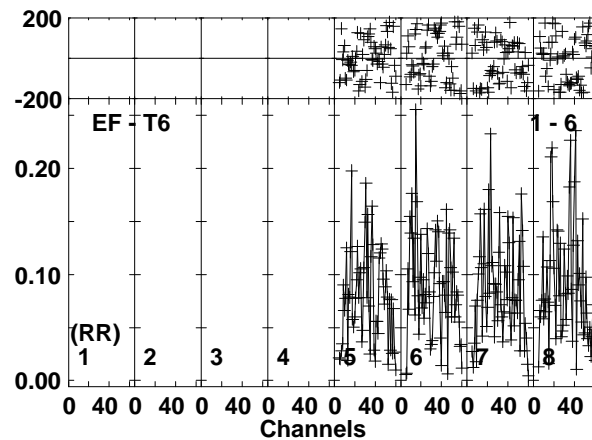
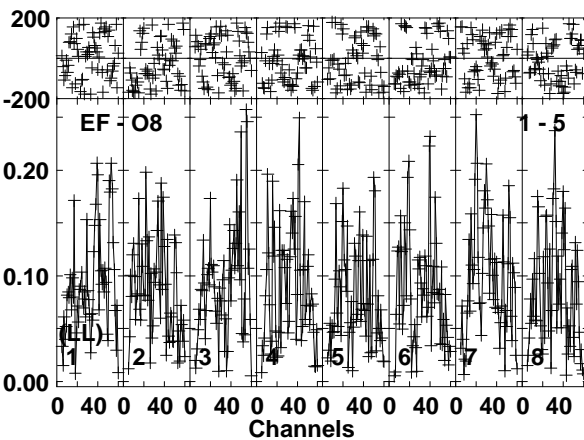
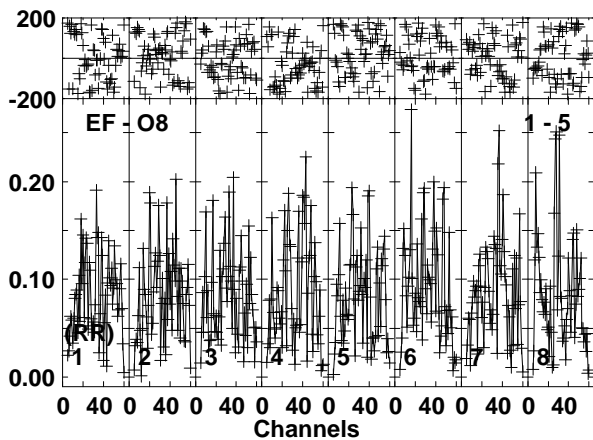
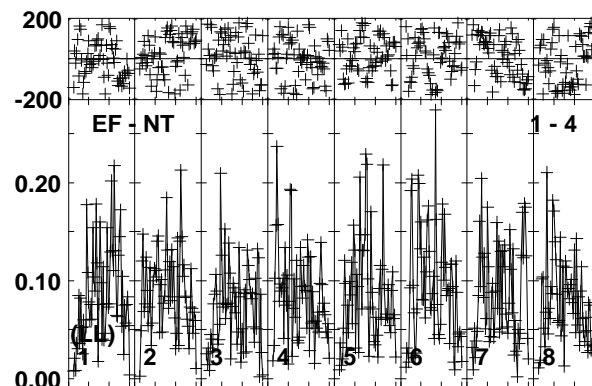
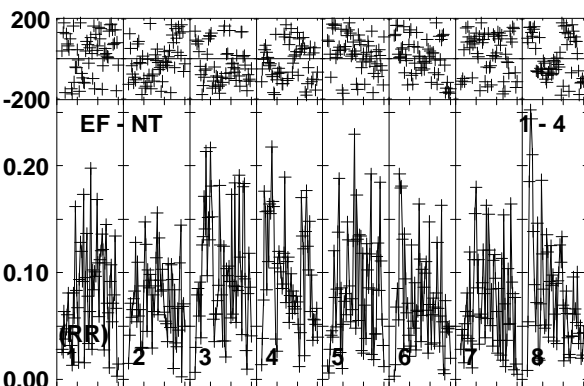
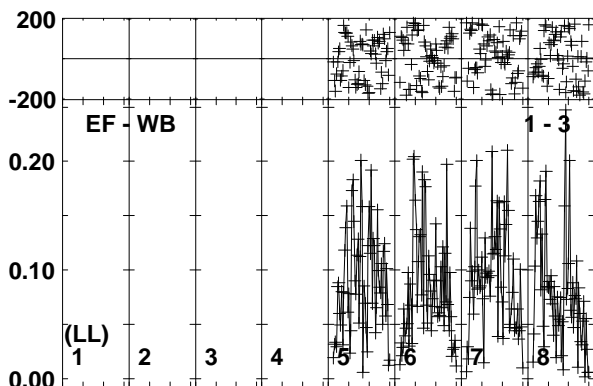
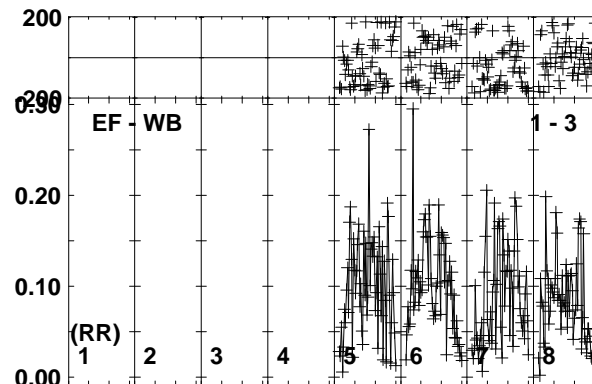
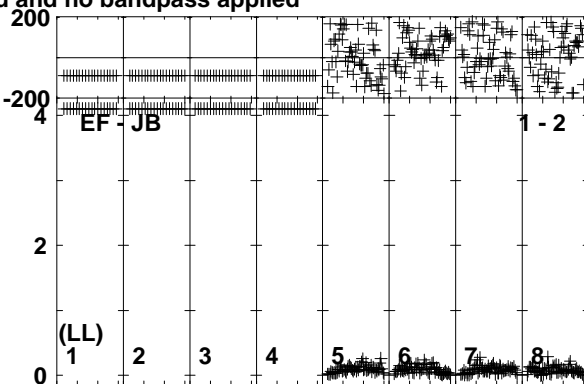
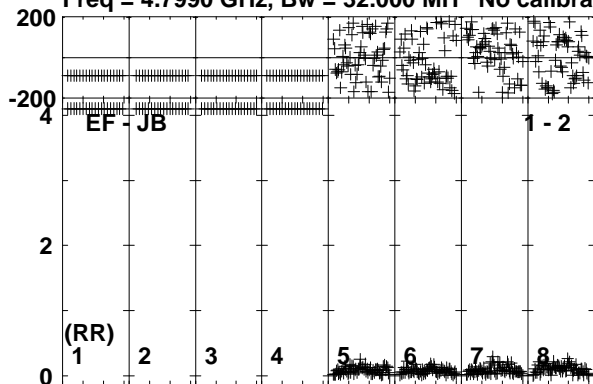

Lower frame: Milli Ampl Jy Top frame: Phas deg
Vector averaged cross-power spectrum Baseline: EF (01) - JB (02)
Timerange: 00/07:06:19 to 00/07:09:48

Plot file version 52 created 03-OCT-2017 13:27:23

ARUMA EG096C.UVDATA.1

Freq = 4.7990 GHz, Bw = 32.000 MH No calibration applied and no bandpass applied

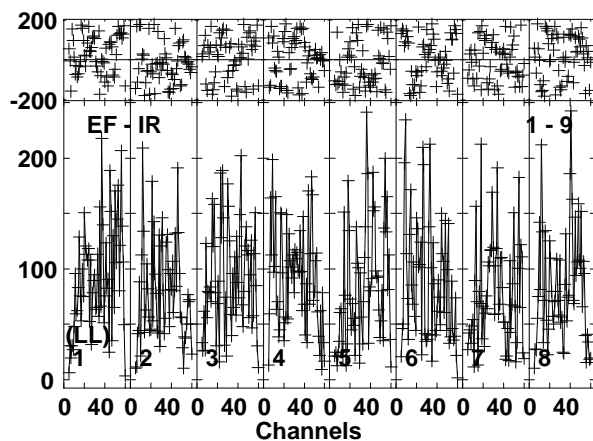
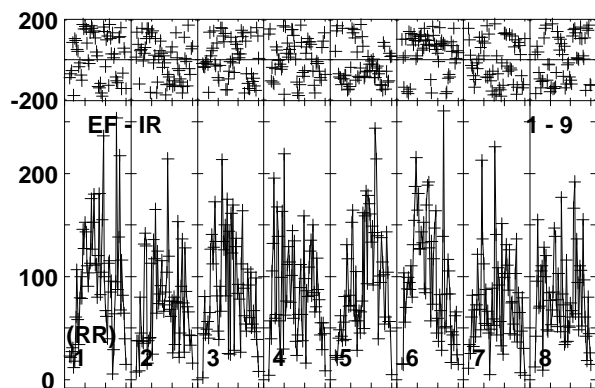
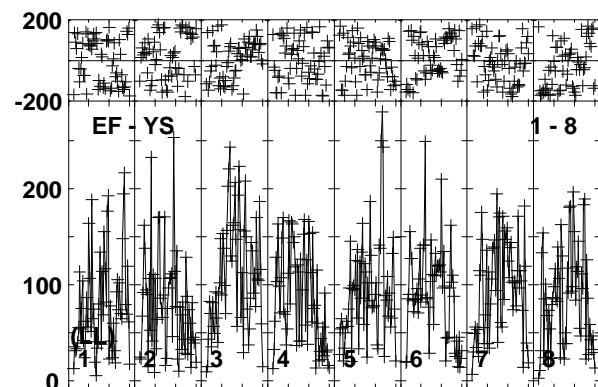
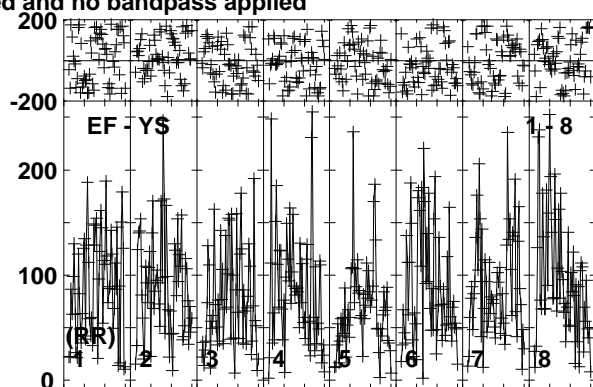
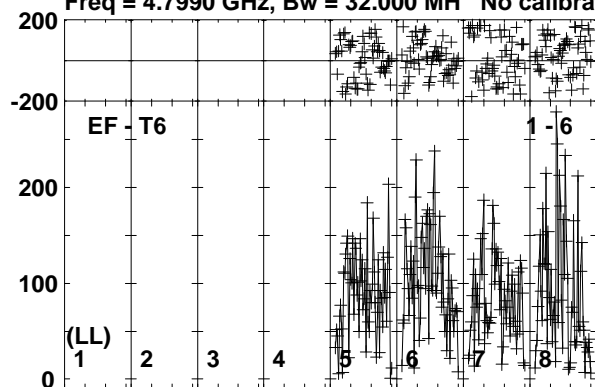

Lower frame: Micro Ampl Jy Top frame: Phas deg
Vector averaged cross-power spectrum Baseline: EF (01) - T6 (06)
Timerange: 00/07:06:19 to 00/07:09:48

Plot file version 53 created 03-OCT-2017 13:27:23

J1108+4330 EG096C.UVDATA.1

Freq = 4.7990 GHz, Bw = 32.000 MH No calibration applied and no bandpass applied

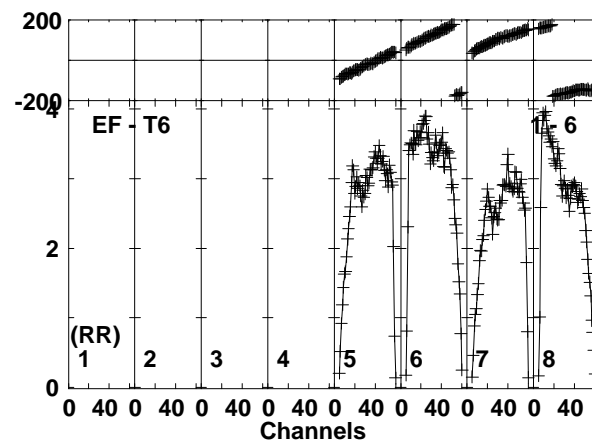
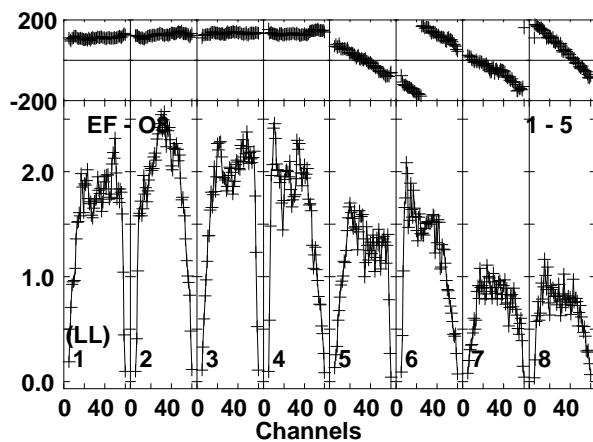
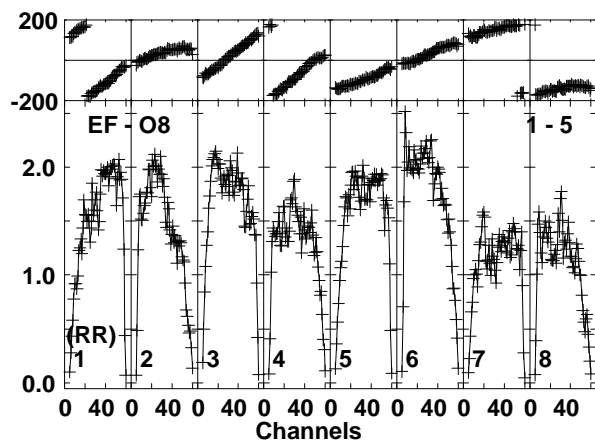
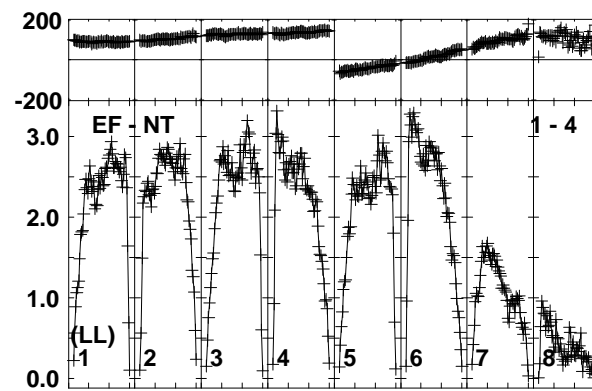
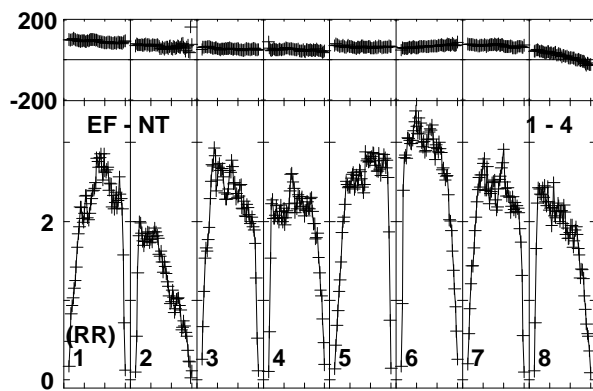
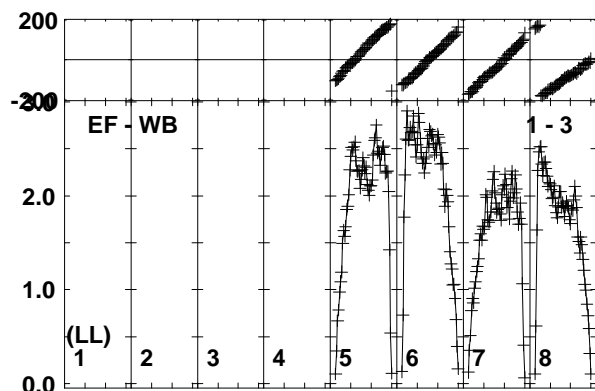
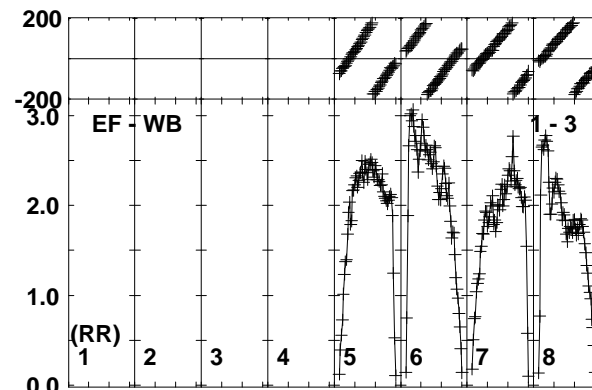
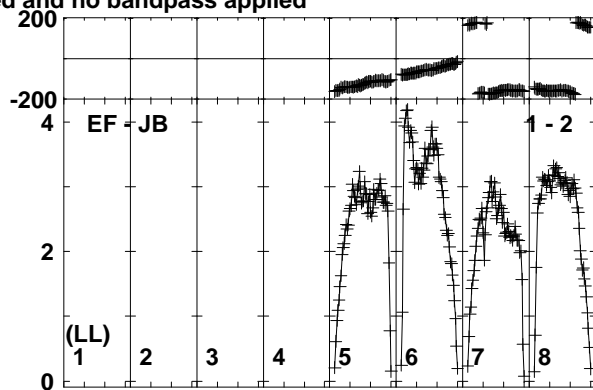
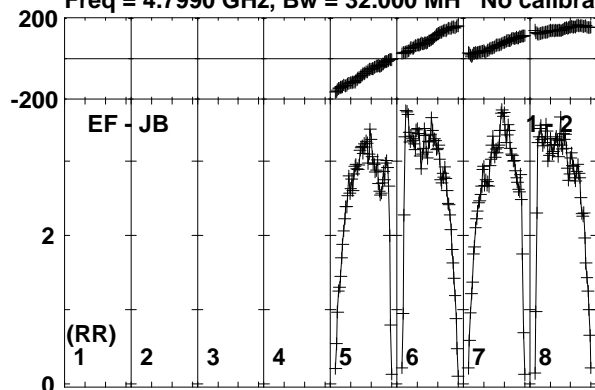

Lower frame: Milli Ampl Jy Top frame: Phas deg
Vector averaged cross-power spectrum Baseline: EF (01) - JB (02)
Timerange: 00/07:10:30 to 00/07:11:28

Plot file version 54 created 03-OCT-2017 13:27:23

J1108+4330 EG096C.UVDATA.1

Freq = 4.7990 GHz, Bw = 32.000 MH No calibration applied and no bandpass applied

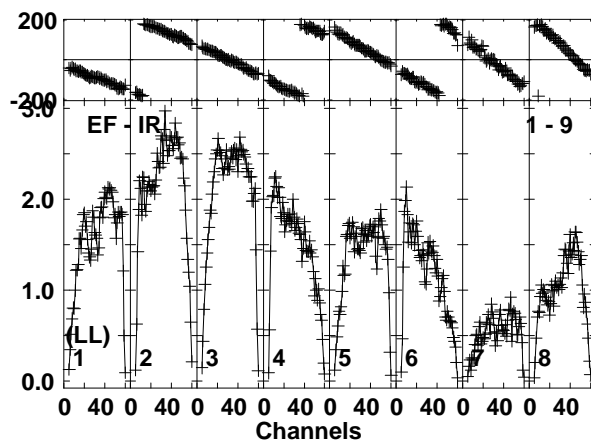
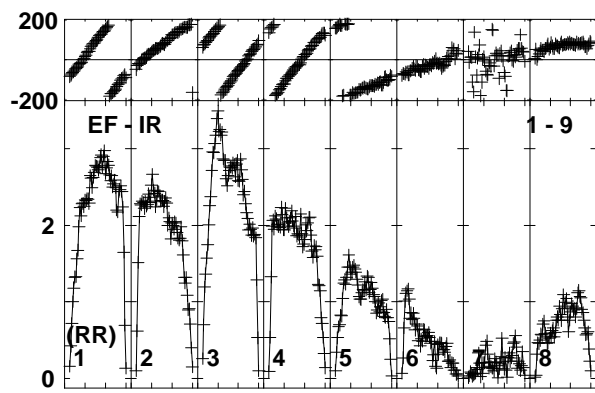
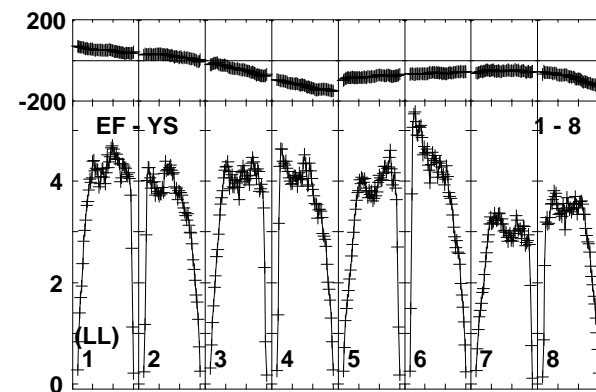
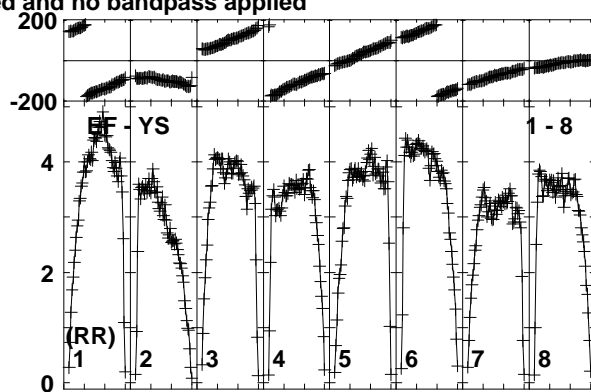
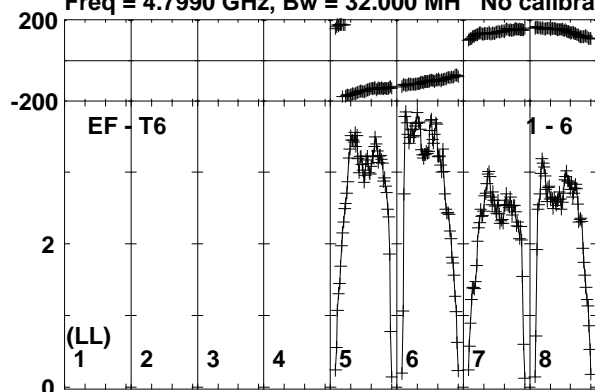

Lower frame: Milli Ampl Jy Top frame: Phas deg
Vector averaged cross-power spectrum Baseline: EF (01) - T6 (06)
Timerange: 00/07:10:30 to 00/07:11:28

Plot file version 55 created 03-OCT-2017 13:27:23

J1112+4301 EG096C.UVDATA.1

Freq = 4.7990 GHz, Bw = 32.000 MH No calibration applied and no bandpass applied

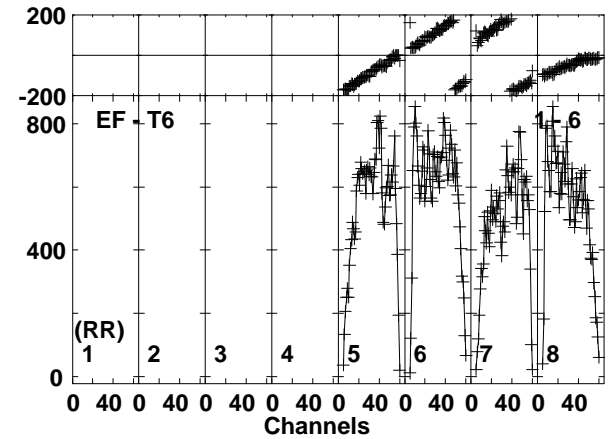
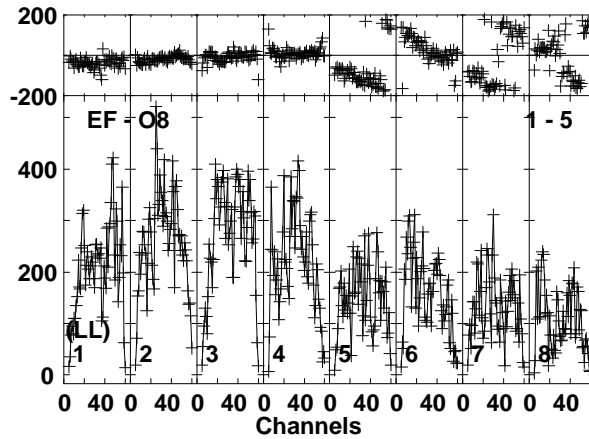
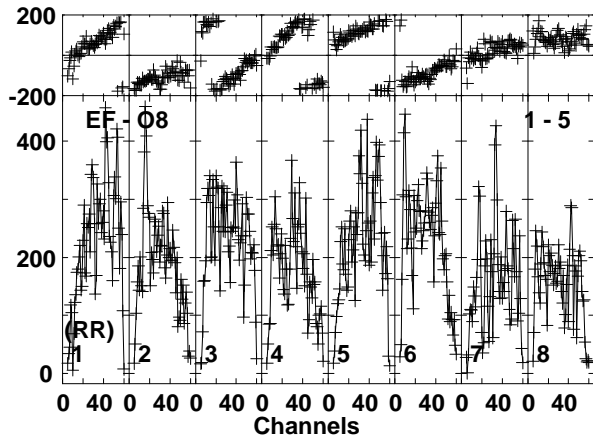
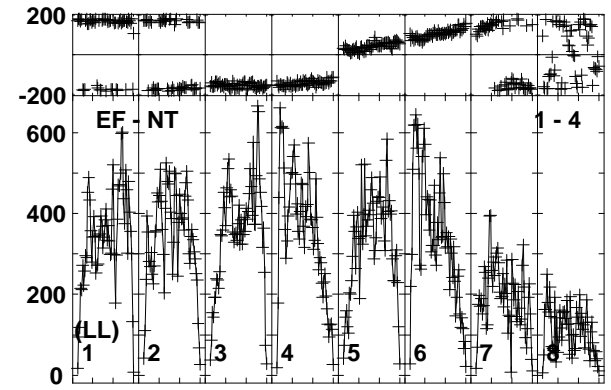
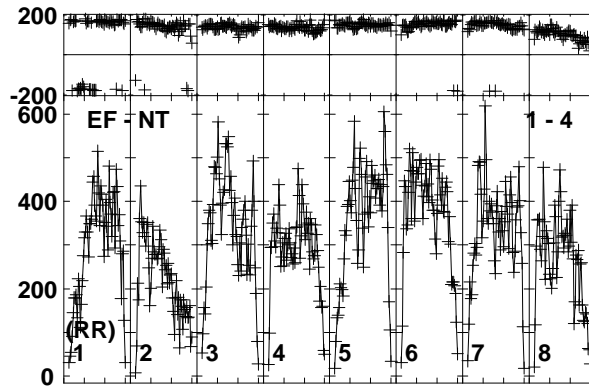
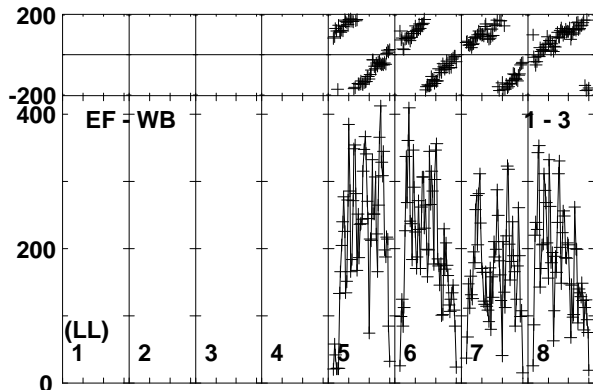
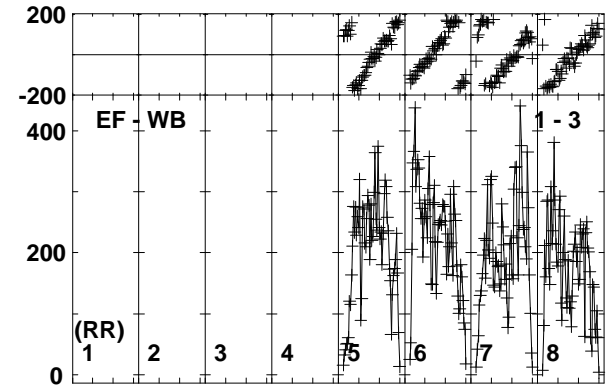
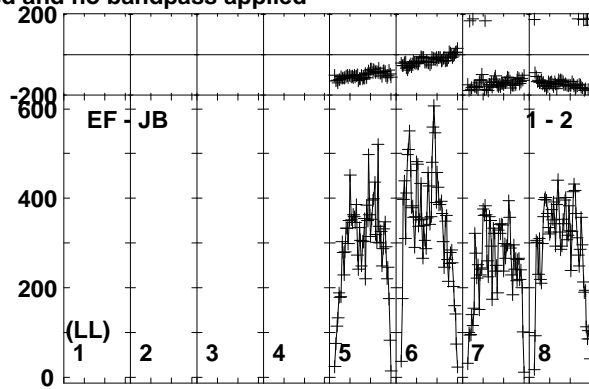
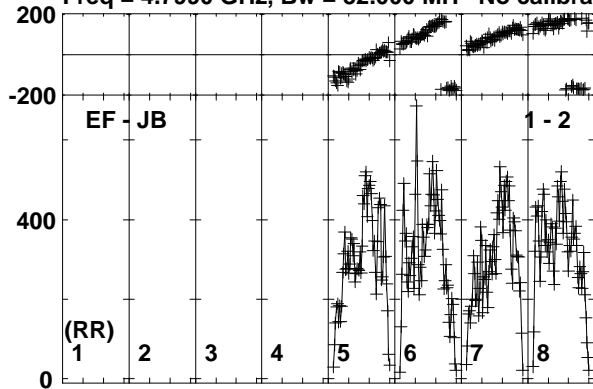

Lower frame: Micro Ampl Jy Top frame: Phas deg
Vector averaged cross-power spectrum Baseline: EF (01) - JB (02)
Timerange: 00/07:11:29 to 00/07:14:58

Plot file version 56 created 03-OCT-2017 13:27:24

J1112+4301 EG096C.UVDATA.1

Freq = 4.7990 GHz, Bw = 32.000 MH No calibration applied and no bandpass applied

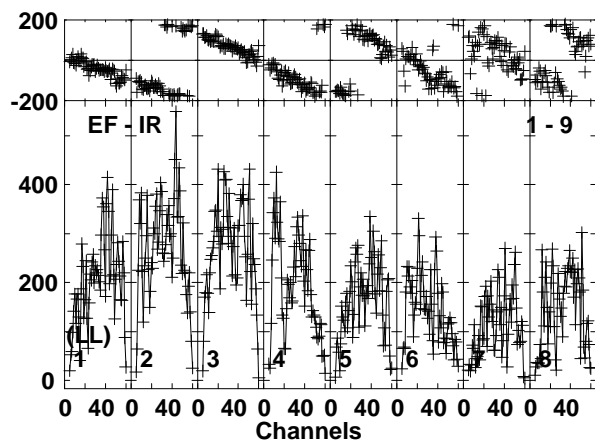
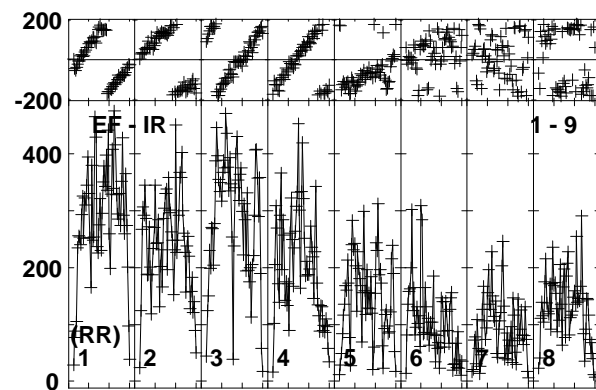
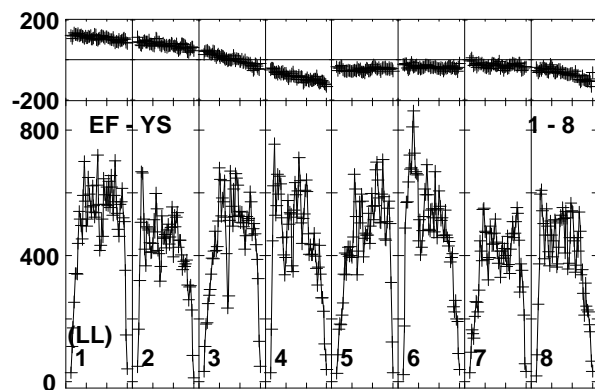
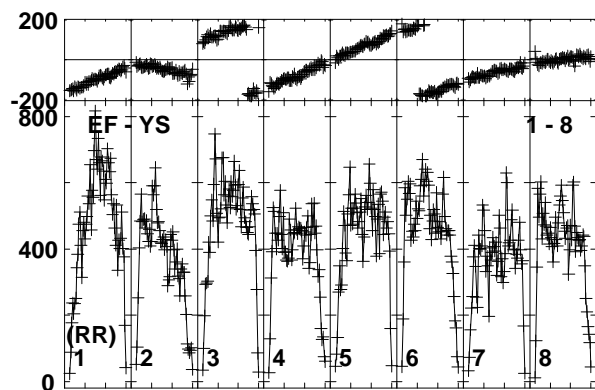
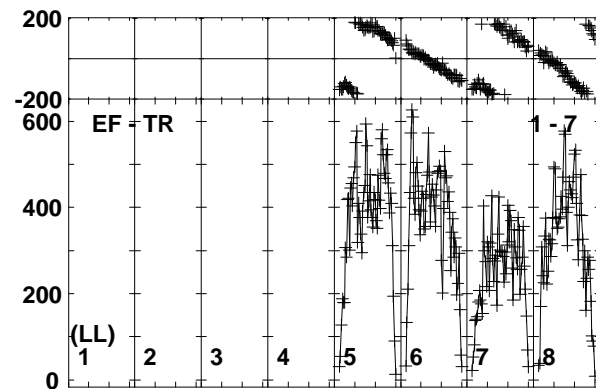
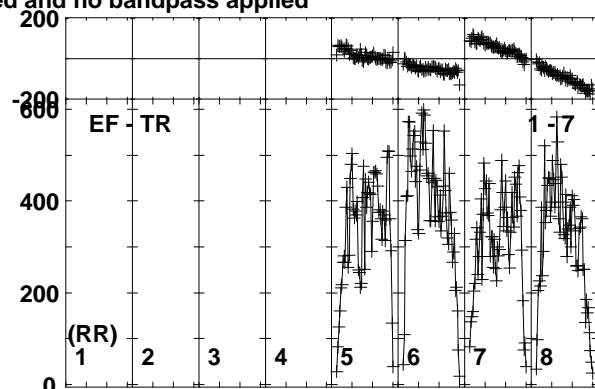
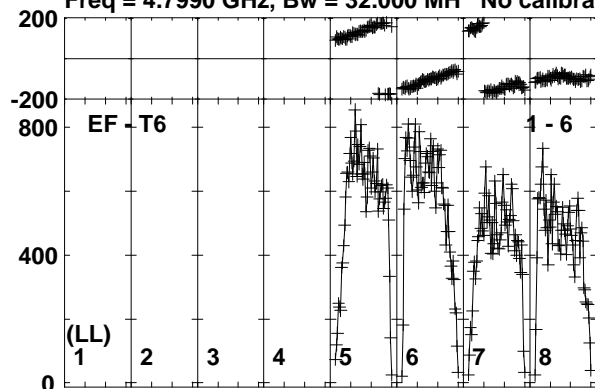

Lower frame: Micro Ampl Jy Top frame: Phas deg
Vector averaged cross-power spectrum Baseline: EF (01) - T6 (06)
Timerange: 00/07:11:29 to 00/07:14:58

Plot file version 57 created 03-OCT-2017 13:27:24

J1108+4330 EG096C.UVDATA.1

Freq = 4.7990 GHz, Bw = 32.000 MH No calibration applied and no bandpass applied

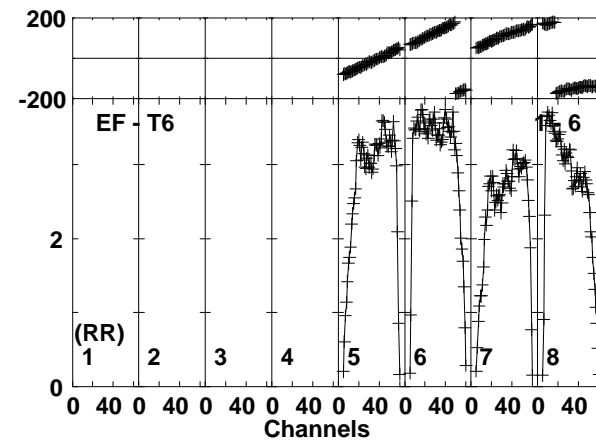
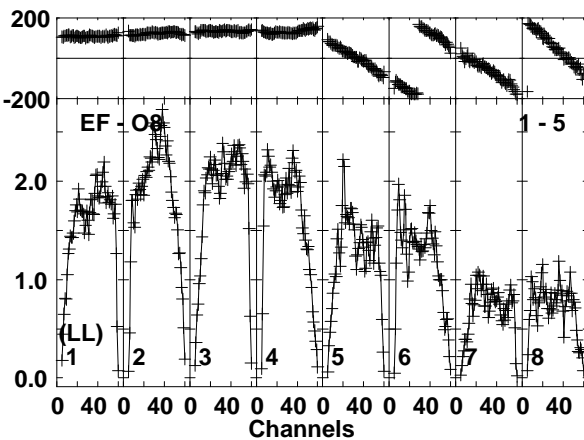
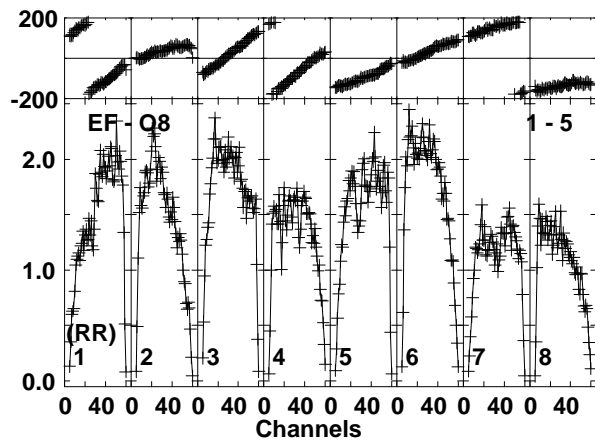
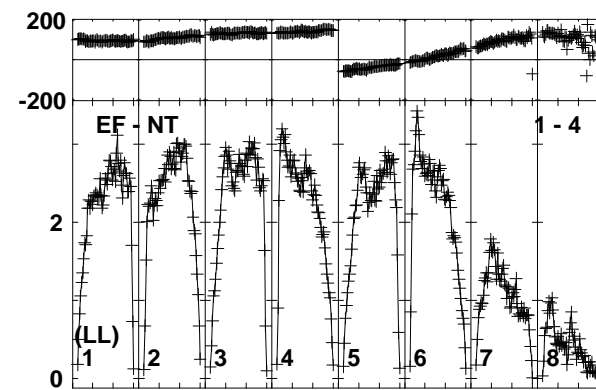
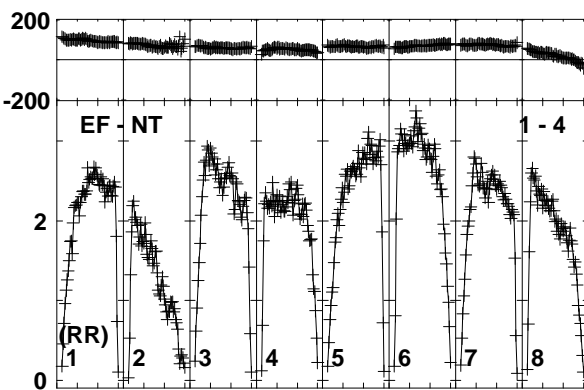
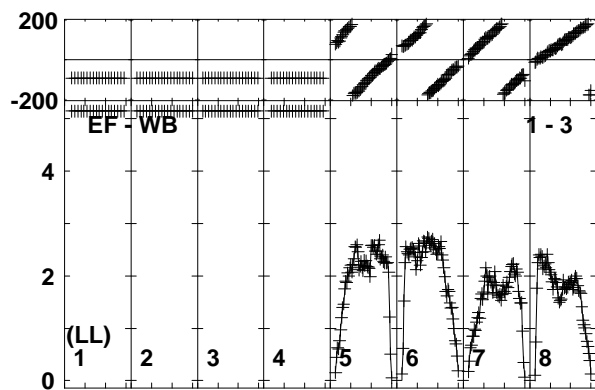
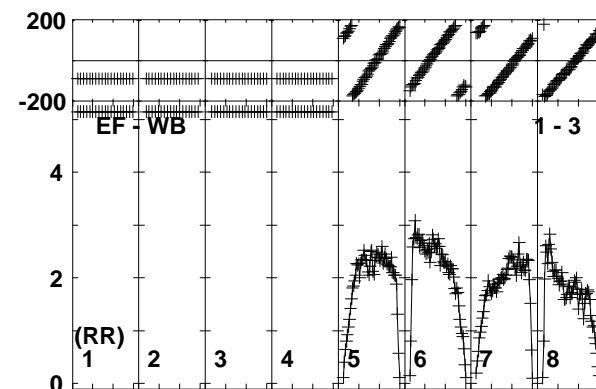
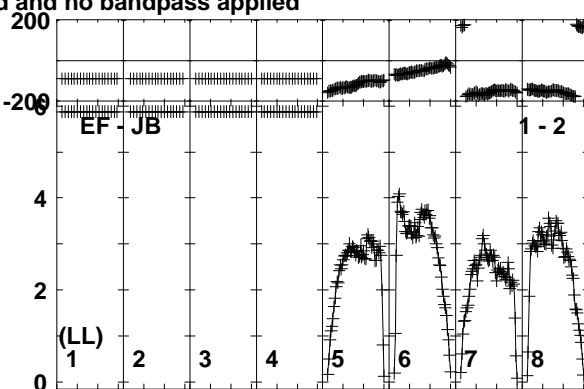
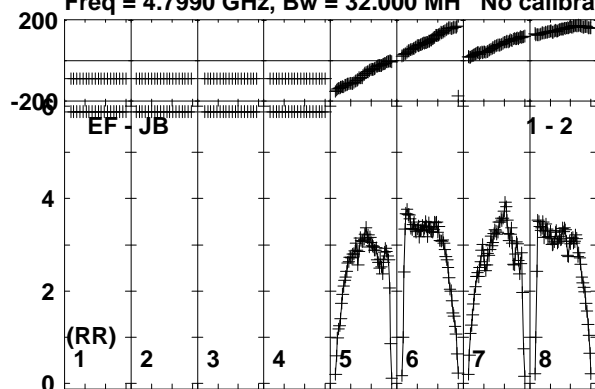

Lower frame: Milli Ampl Jy Top frame: Phas deg
Vector averaged cross-power spectrum Baseline: EF (01) - JB (02)
Timerange: 00/07:14:59 to 00/07:16:28

Plot file version 58 created 03-OCT-2017 13:27:24

J1108+4330 EG096C.UVDATA.1

Freq = 4.7990 GHz, Bw = 32.000 MH No calibration applied and no bandpass applied

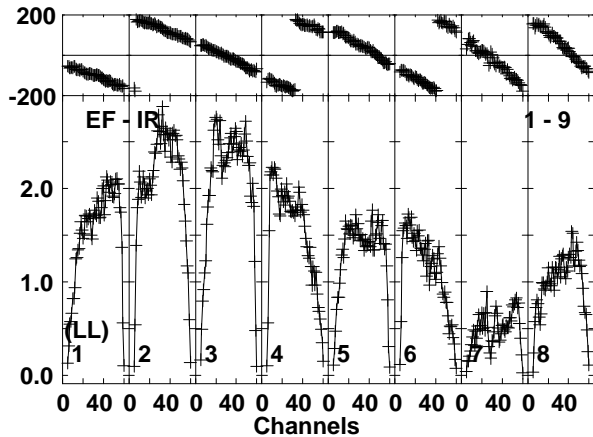
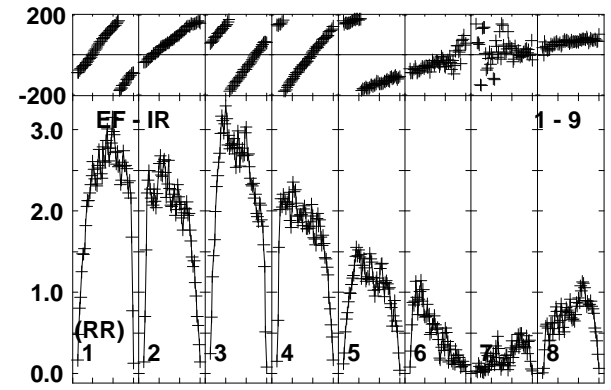
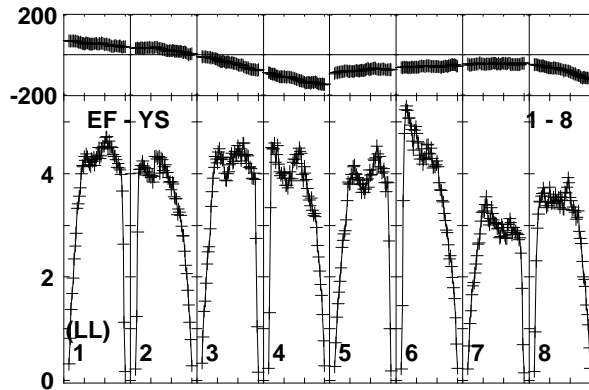
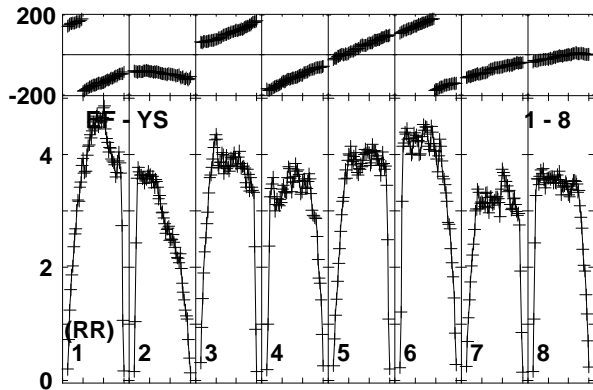
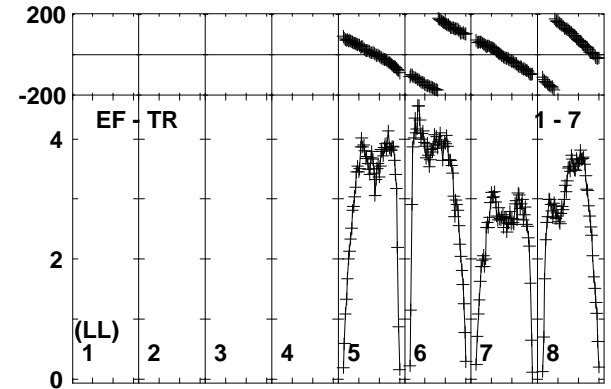
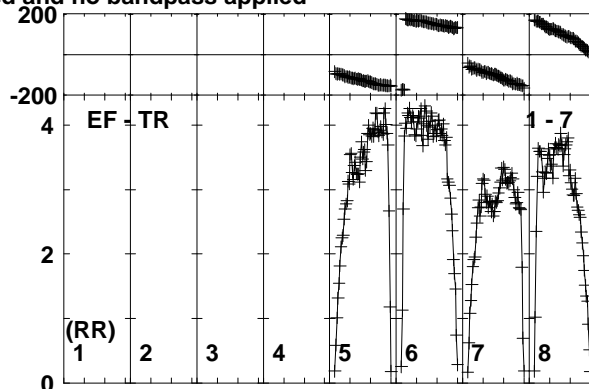
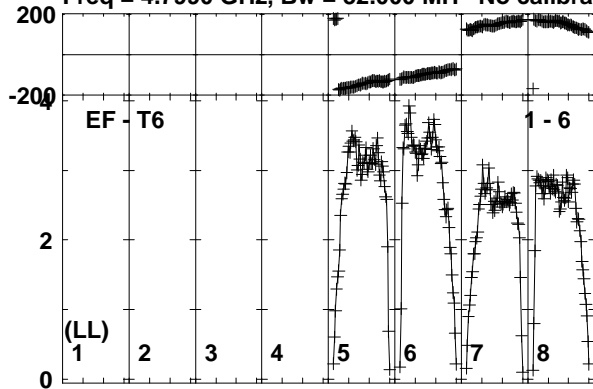

Lower frame: Milli Ampl Jy Top frame: Phas deg
Vector averaged cross-power spectrum Baseline: EF (01) - T6 (06)
Timerange: 00/07:14:59 to 00/07:16:28

Plot file version 59 created 03-OCT-2017 13:27:24

ARUMA EG096C.UVDATA.1

Freq = 4.7990 GHz, Bw = 32.000 MH No calibration applied and no bandpass applied

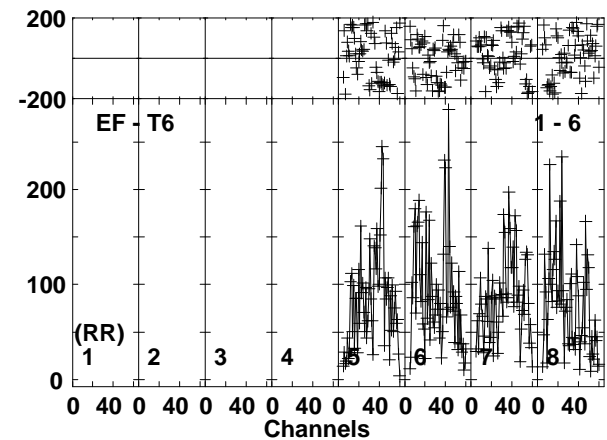
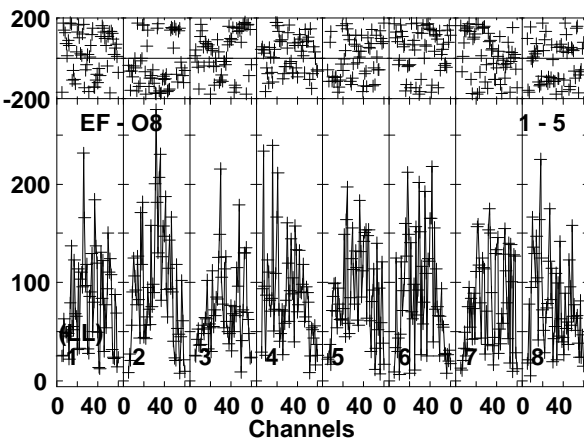
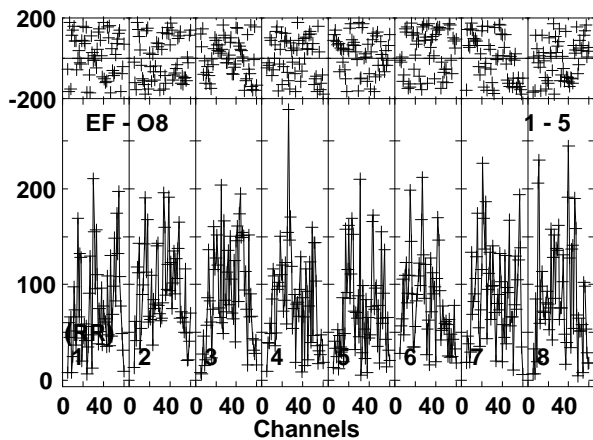
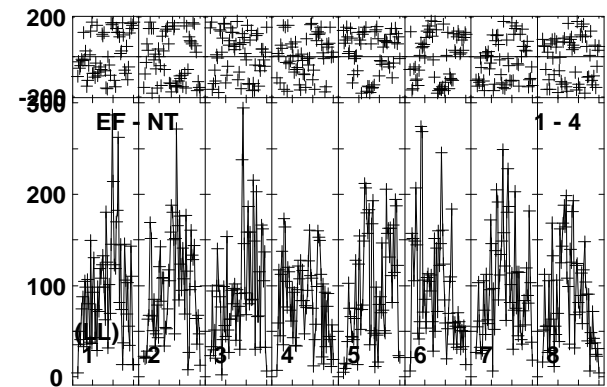
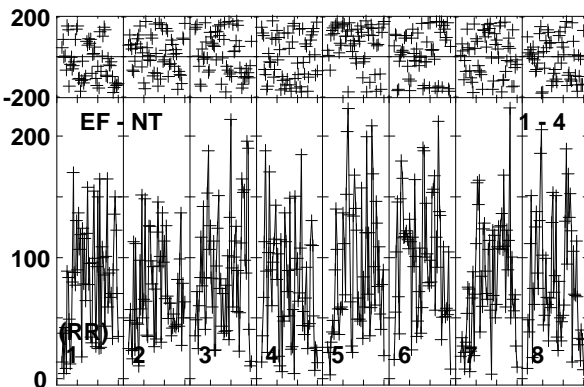
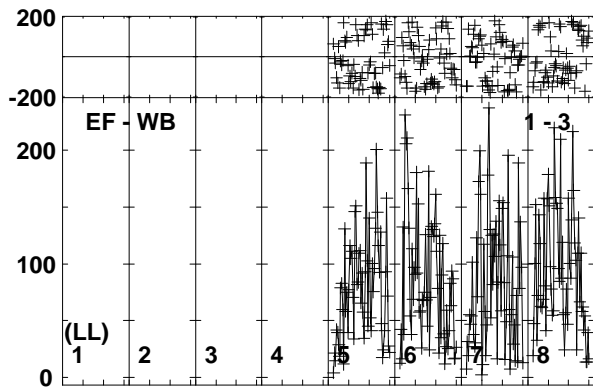
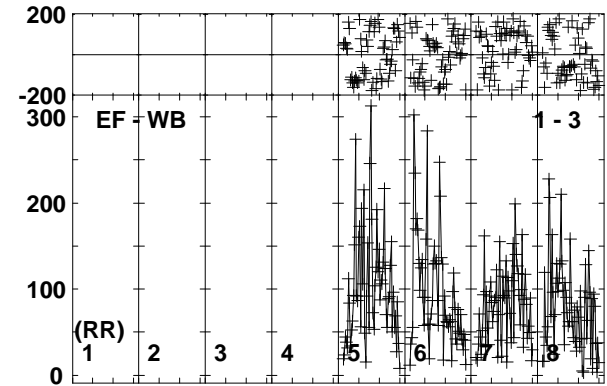
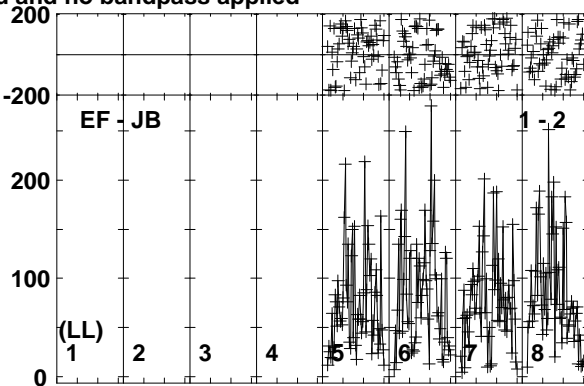
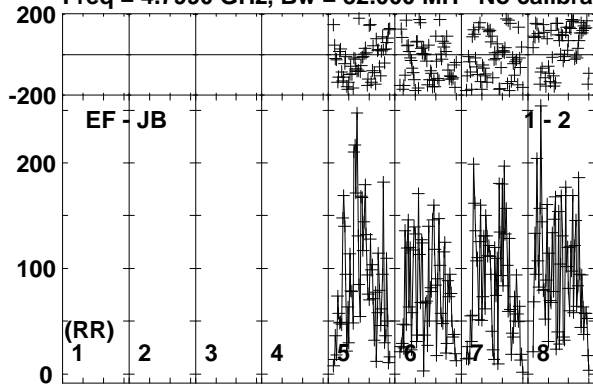

Lower frame: Micro Ampl Jy Top frame: Phas deg
Vector averaged cross-power spectrum Baseline: EF (01) - JB (02)
Timerange: 00/07:16:30 to 00/07:19:59

Plot file version 60 created 03-OCT-2017 13:27:25

ARUMA EG096C.UVDATA.1

Freq = 4.7990 GHz, Bw = 32.000 MH No calibration applied and no bandpass applied

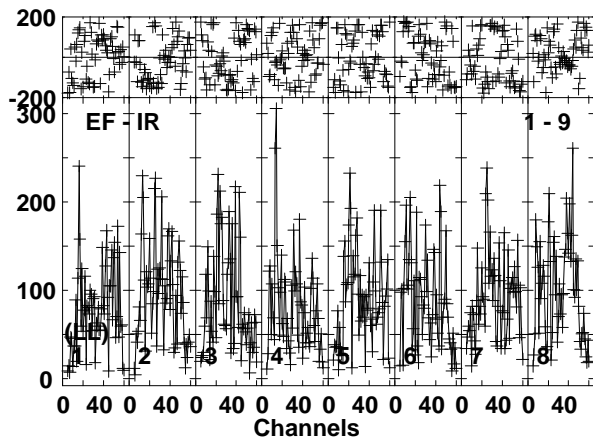
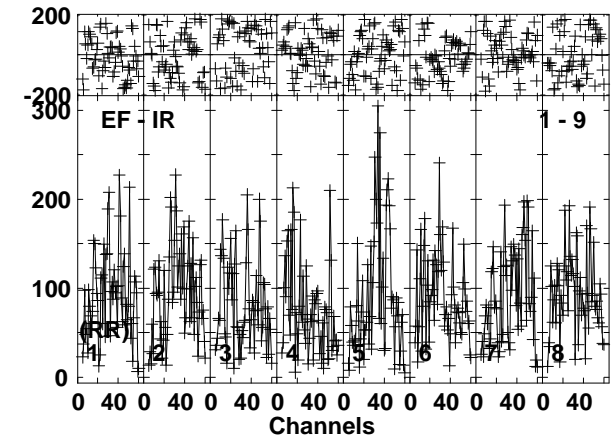
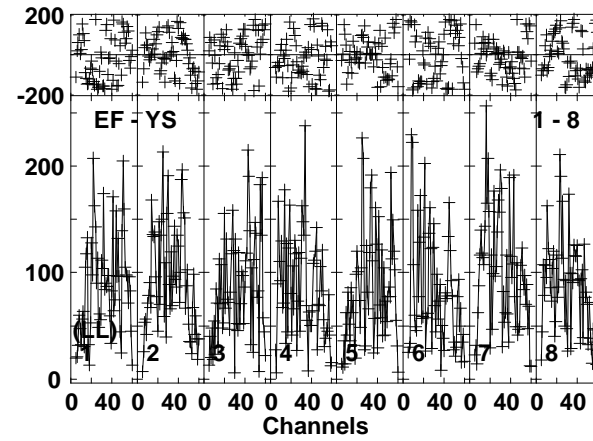
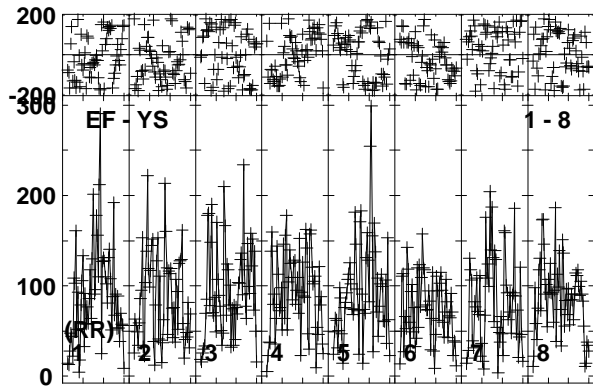
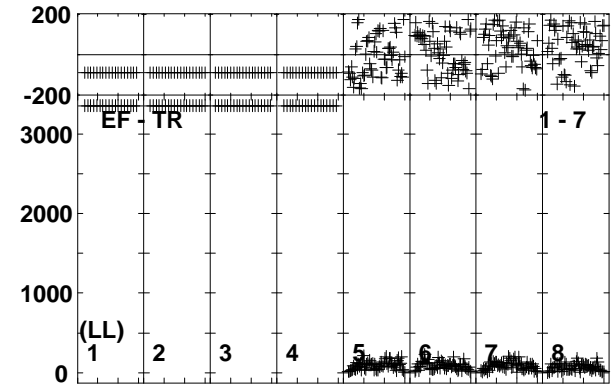
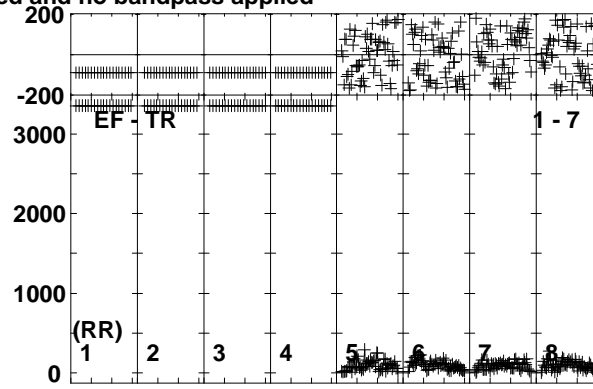
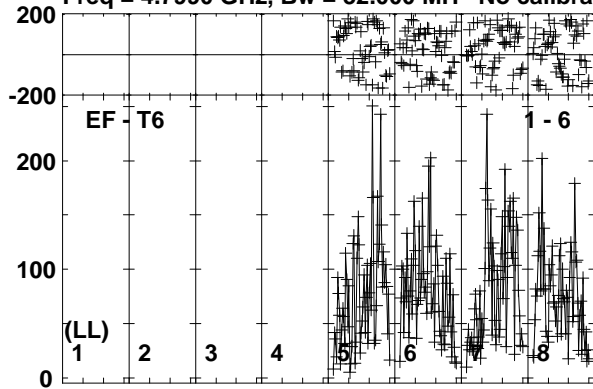

Lower frame: Micro Ampl Jy Top frame: Phas deg
Vector averaged cross-power spectrum Baseline: EF (01) - T6 (06)
Timerange: 00/07:16:30 to 00/07:19:59

Plot file version 61 created 03-OCT-2017 13:27:25

J1108+4330 EG096C.UVDATA.1

Freq = 4.7990 GHz, Bw = 32.000 MH No calibration applied and no bandpass applied

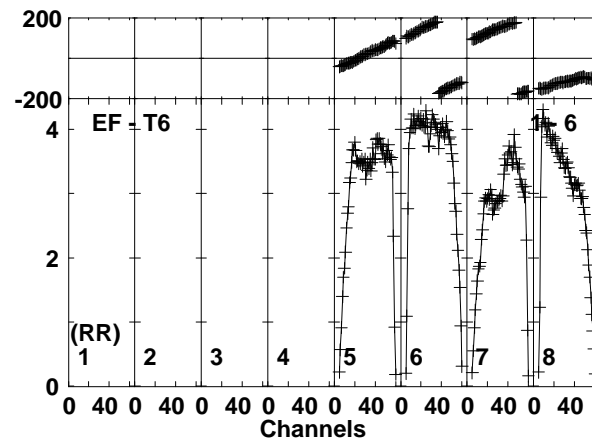
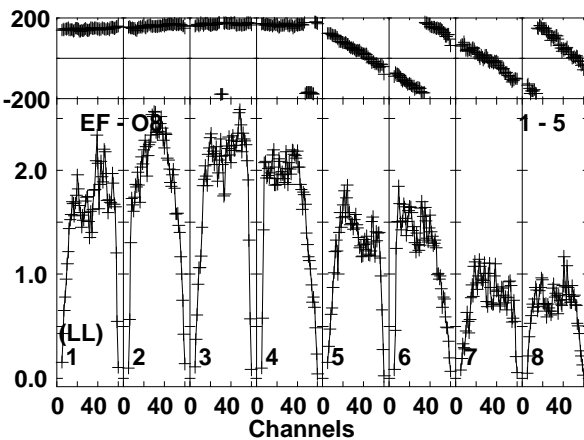
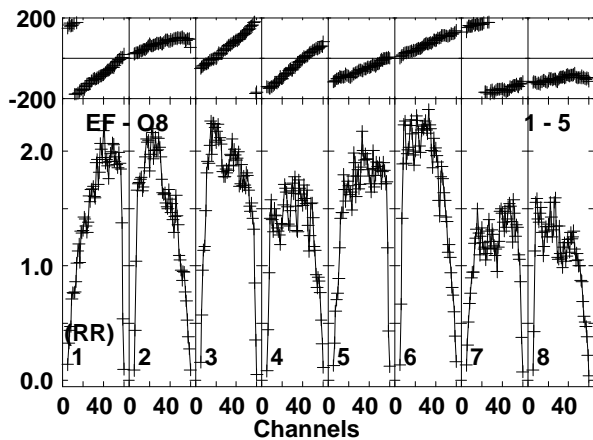
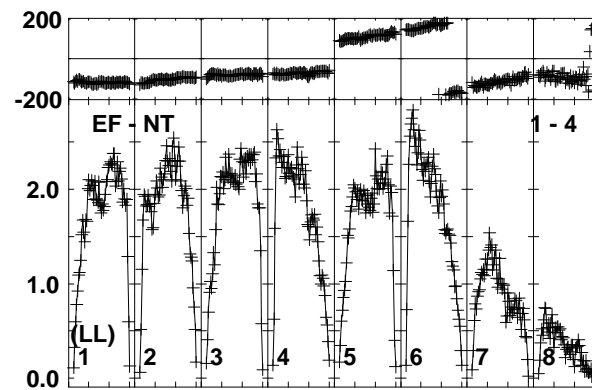
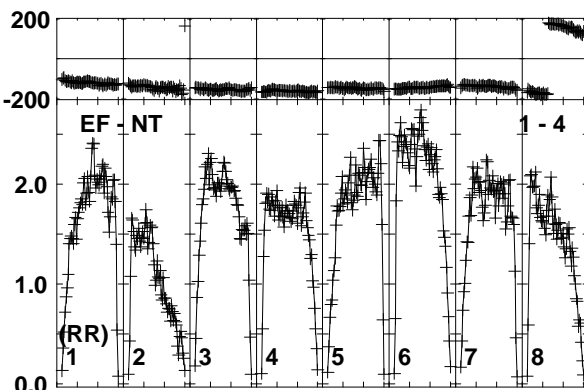
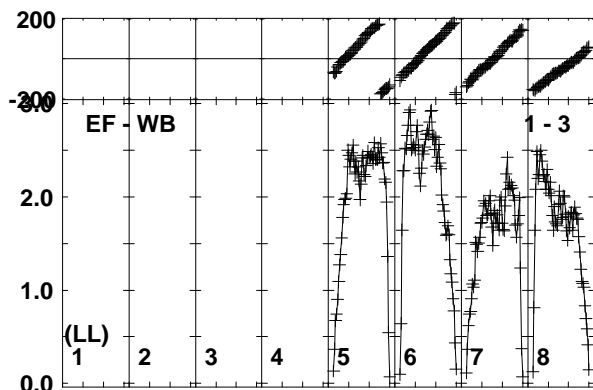
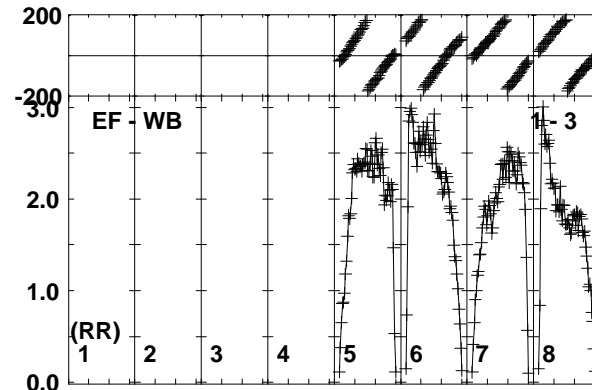
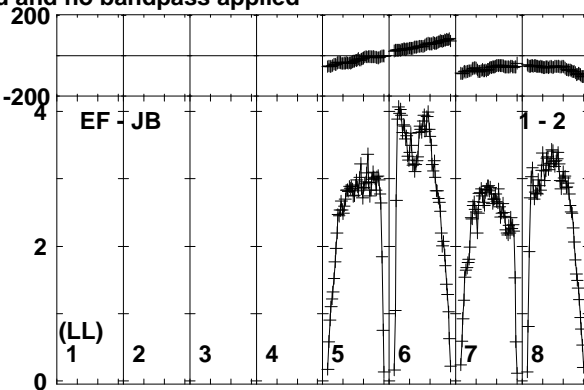
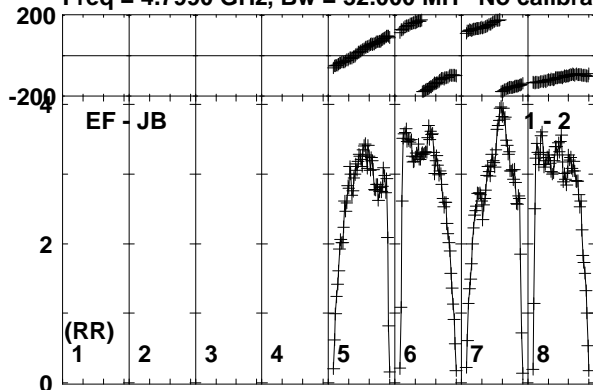

Lower frame: Milli Ampl Jy Top frame: Phas deg
Vector averaged cross-power spectrum Baseline: EF (01) - JB (02)
Timerange: 00/07:20:39 to 00/07:21:39

Plot file version 62 created 03-OCT-2017 13:27:25

J1108+4330 EG096C.UVDATA.1

Freq = 4.7990 GHz, Bw = 32.000 MH No calibration applied and no bandpass applied

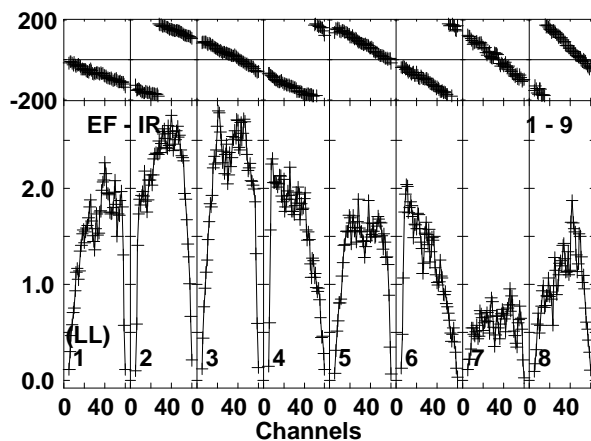
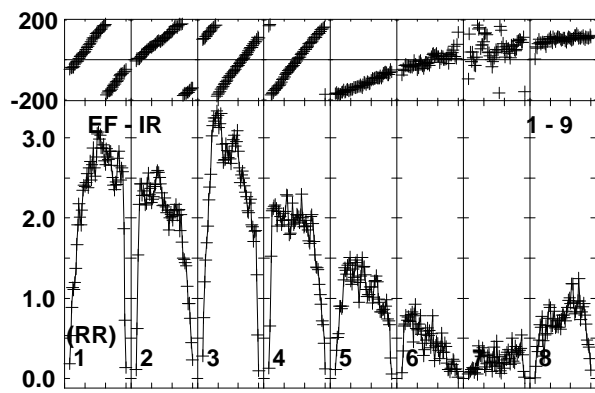
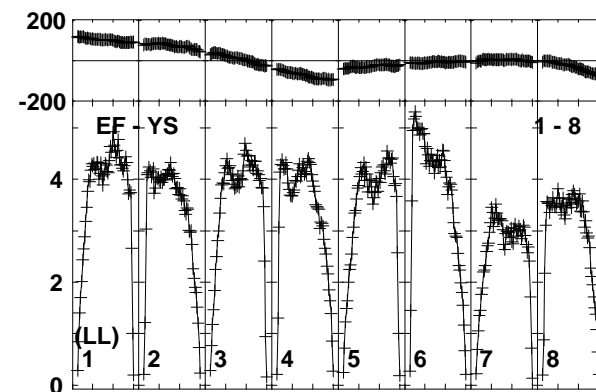
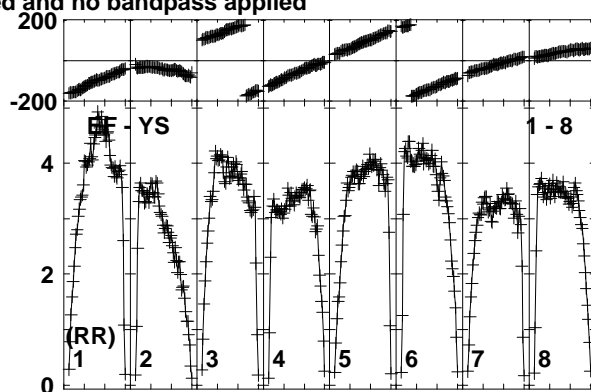
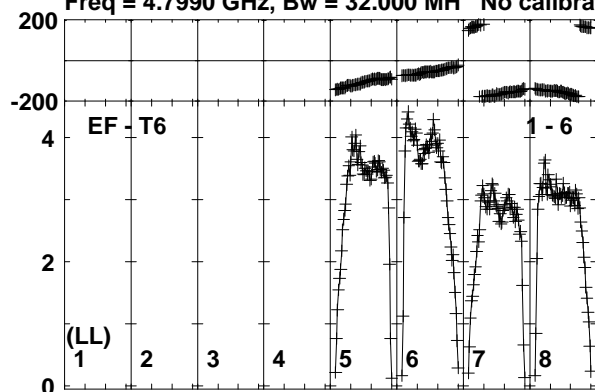

Lower frame: Milli Ampl Jy Top frame: Phas deg
Vector averaged cross-power spectrum Baseline: EF (01) - T6 (06)
Timerange: 00/07:20:39 to 00/07:21:39

Plot file version 63 created 03-OCT-2017 13:27:25

ARUMA EG096C.UVDATA.1

Freq = 4.7990 GHz, Bw = 32.000 MH No calibration applied and no bandpass applied

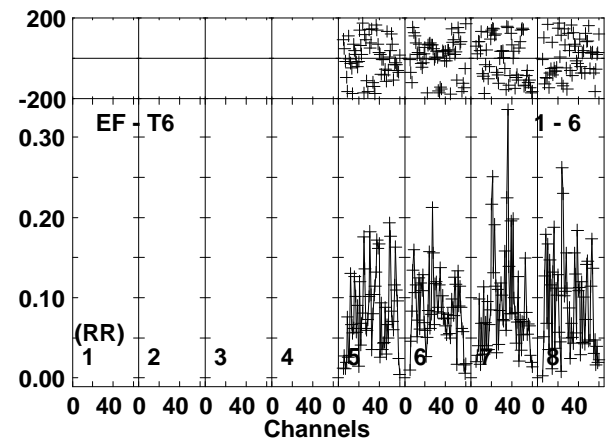
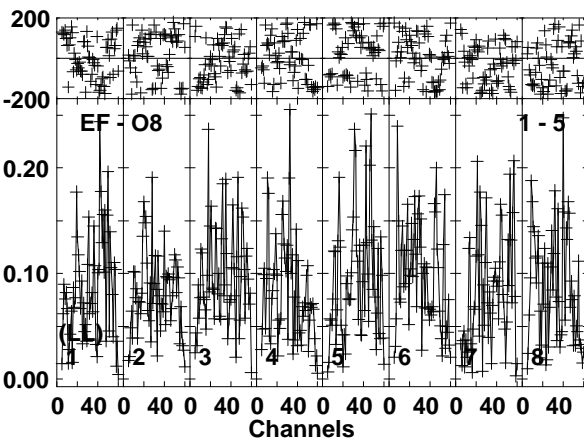
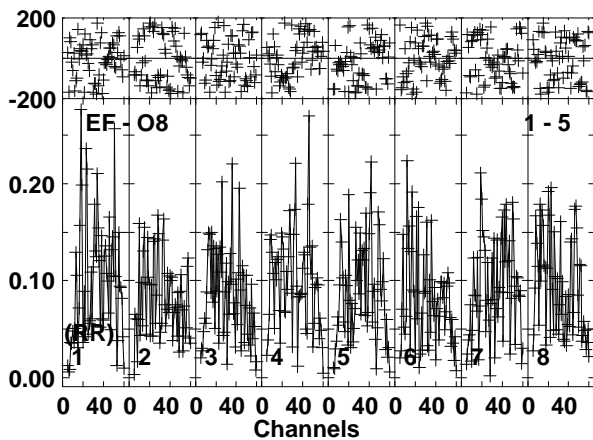
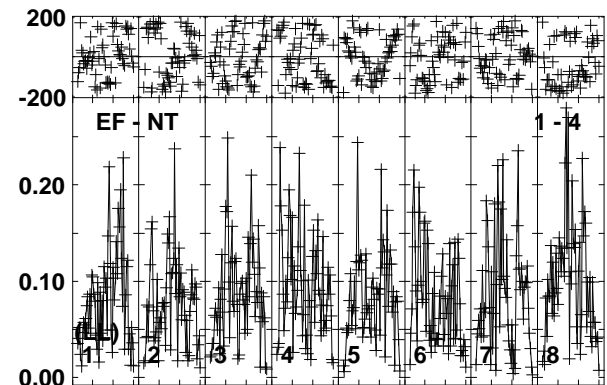
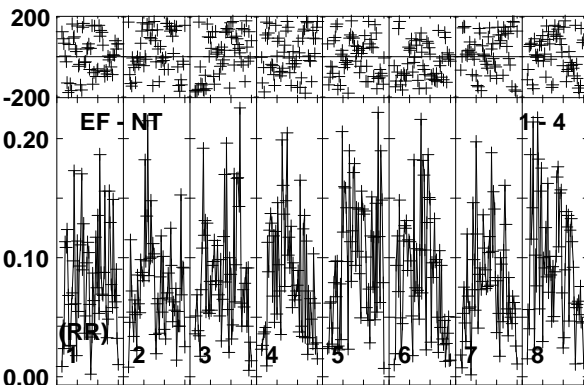
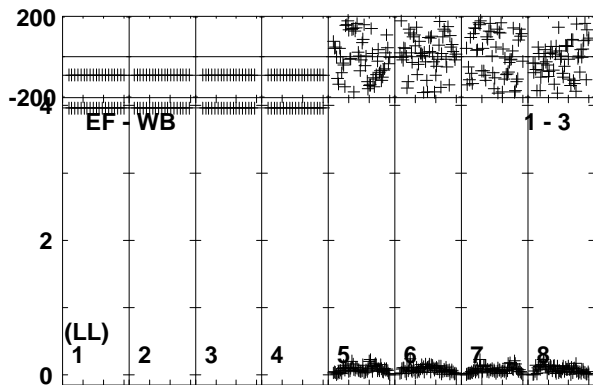
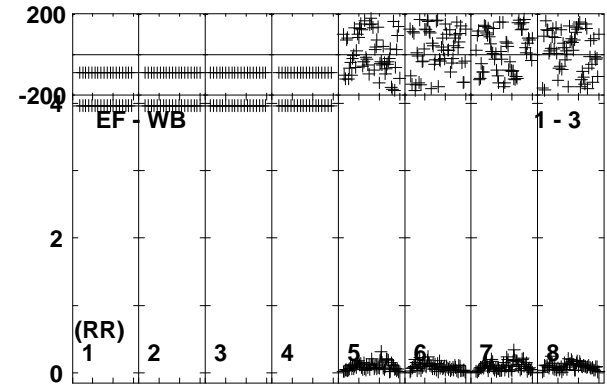
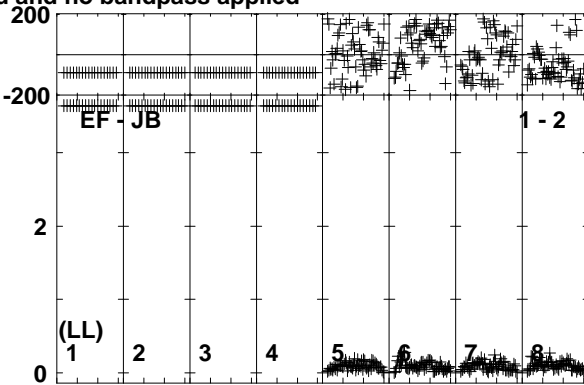
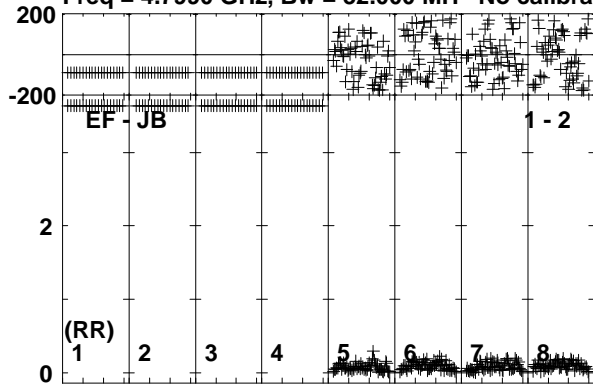

Lower frame: Milli Ampl Jy Top frame: Phas deg
Vector averaged cross-power spectrum Baseline: EF (01) - JB (02)
Timerange: 00/07:21:40 to 00/07:25:09

Plot file version 64 created 03-OCT-2017 13:27:26

ARUMA EG096C.UVDATA.1

Freq = 4.7990 GHz, Bw = 32.000 MH No calibration applied and no bandpass applied

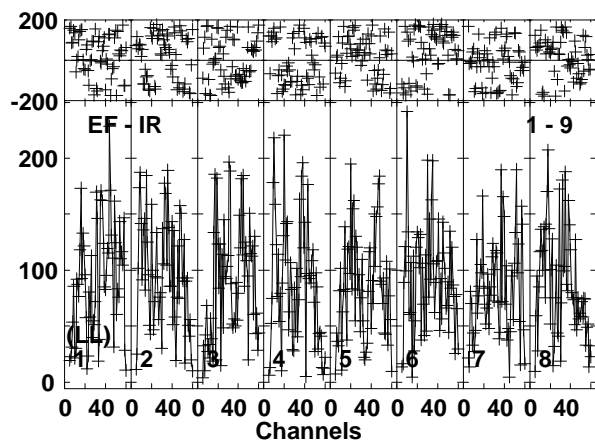
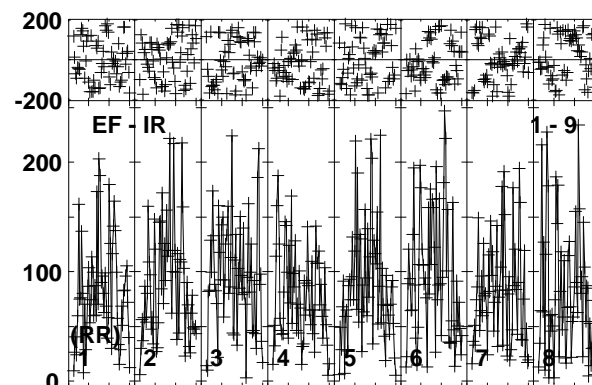
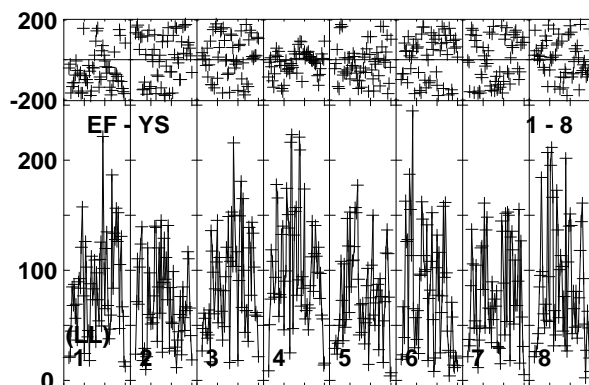
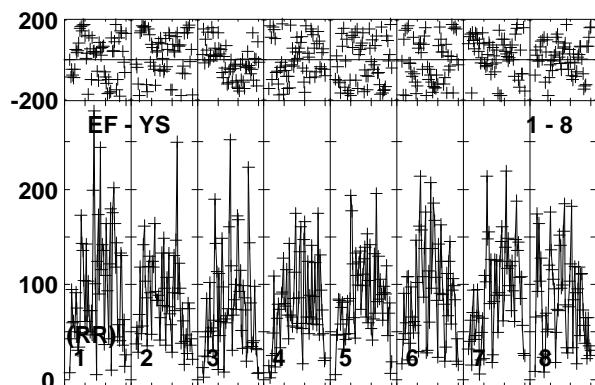
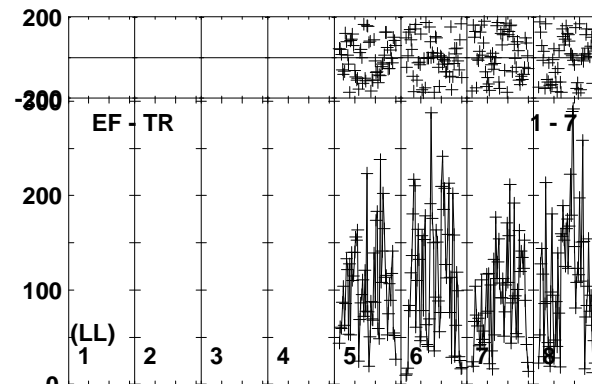
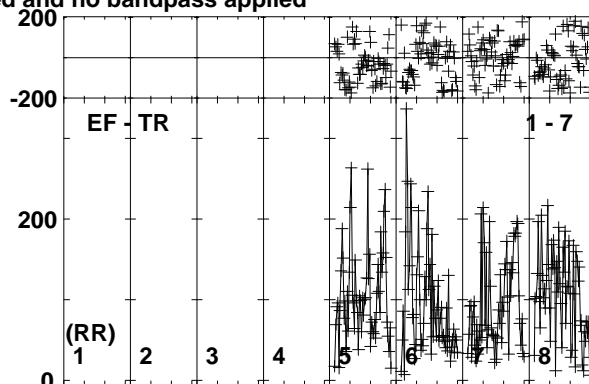
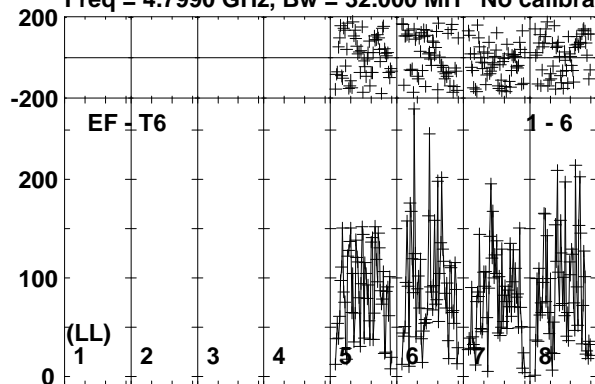

Lower frame: Micro Ampl Jy Top frame: Phas deg
Vector averaged cross-power spectrum Baseline: EF (01) - T6 (06)
Timerange: 00/07:21:40 to 00/07:25:09

Plot file version 65 created 03-OCT-2017 13:27:26

J1108+4330 EG096C.UVDATA.1

Freq = 4.7990 GHz, Bw = 32.000 MH No calibration applied and no bandpass applied

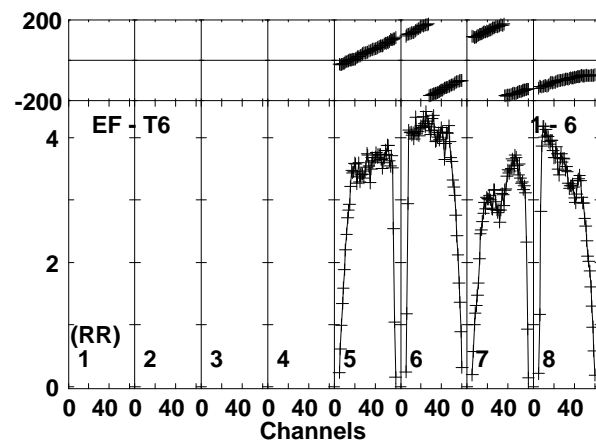
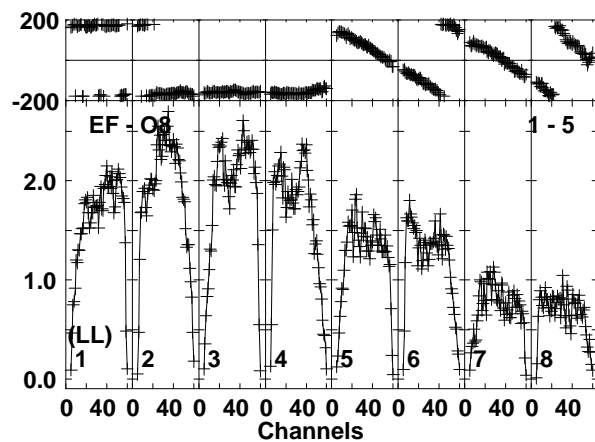
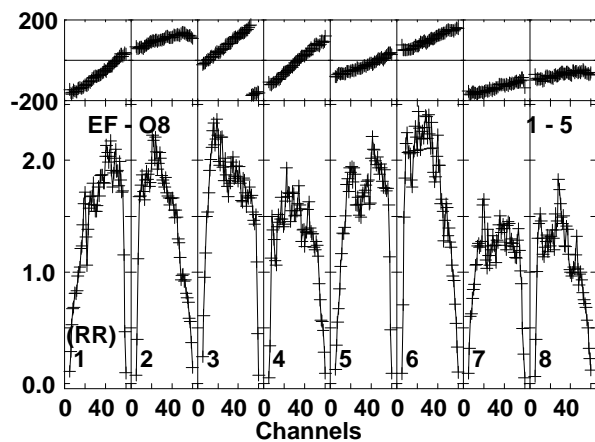
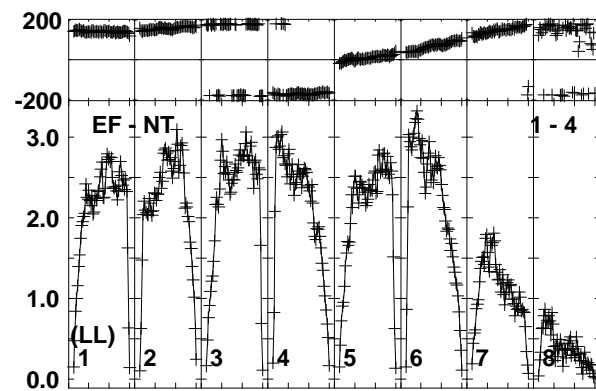
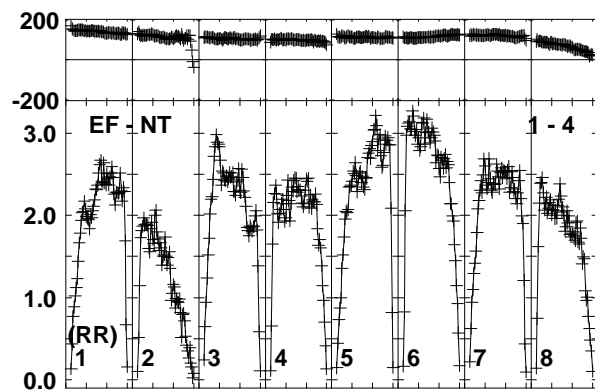
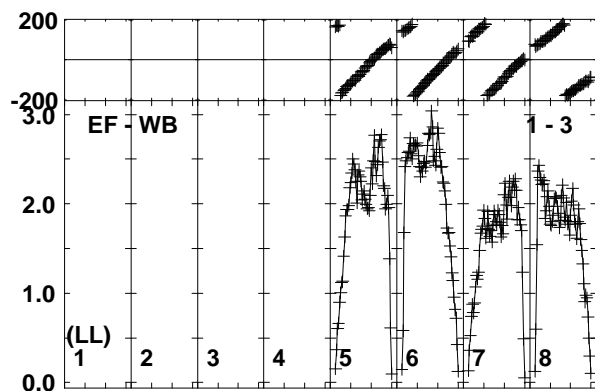
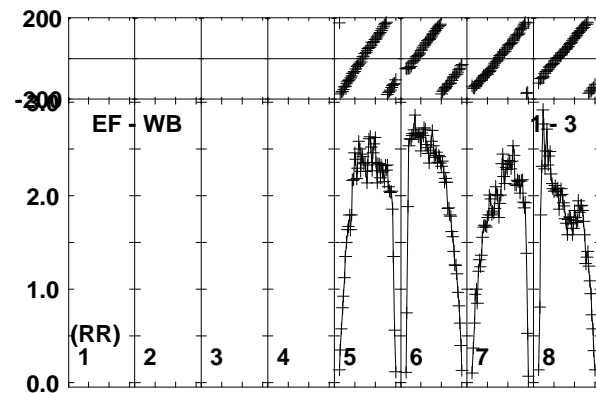
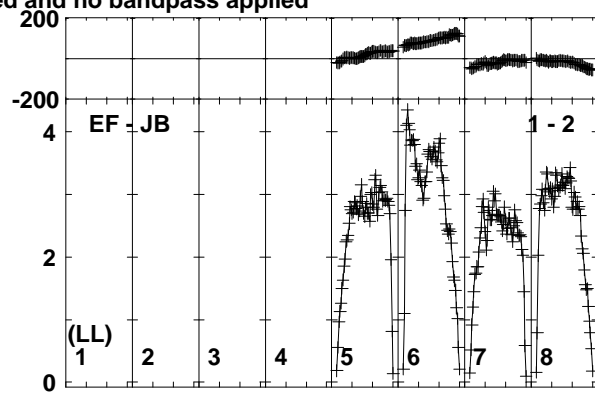
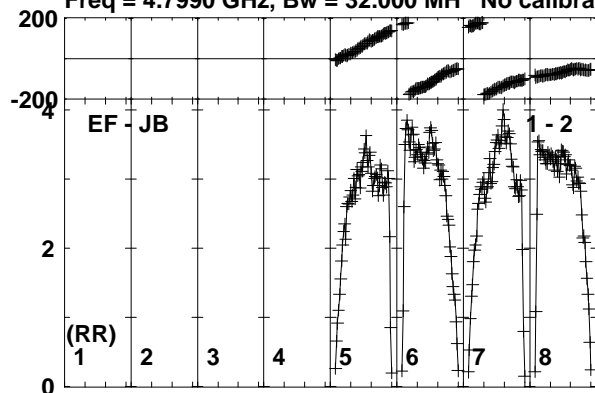

Lower frame: Milli Ampl Jy Top frame: Phas deg
Vector averaged cross-power spectrum Baseline: EF (01) - JB (02)
Timerange: 00/07:25:10 to 00/07:26:39

Plot file version 66 created 03-OCT-2017 13:27:26

J1108+4330 EG096C.UVDATA.1

Freq = 4.7990 GHz, Bw = 32.000 MH No calibration applied and no bandpass applied

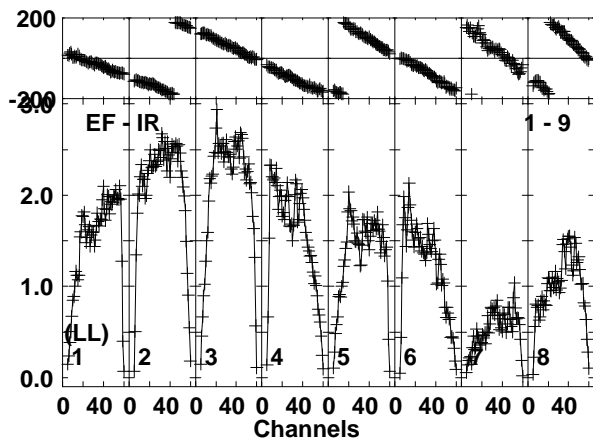
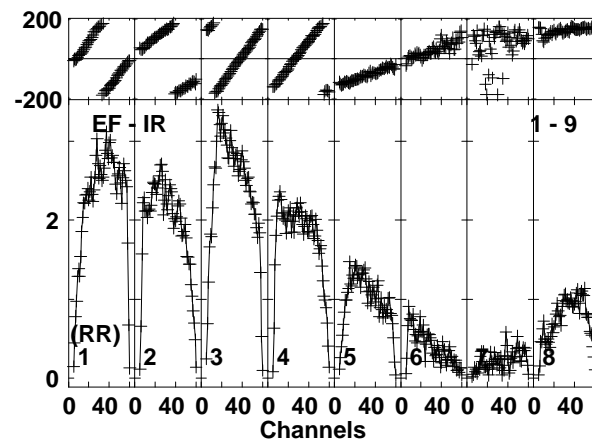
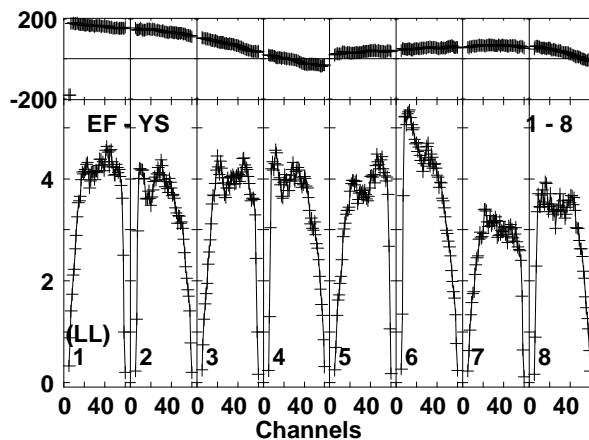
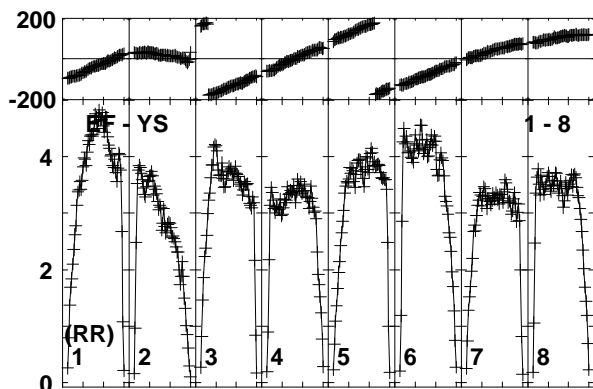
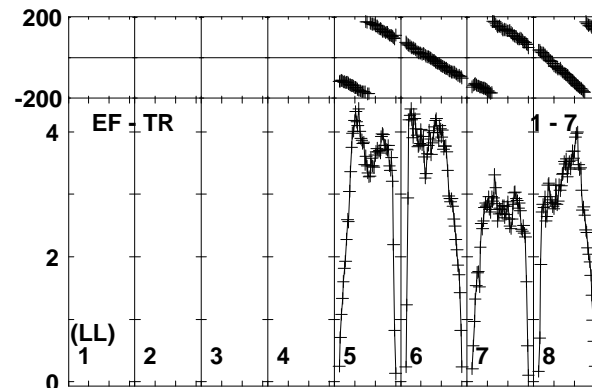
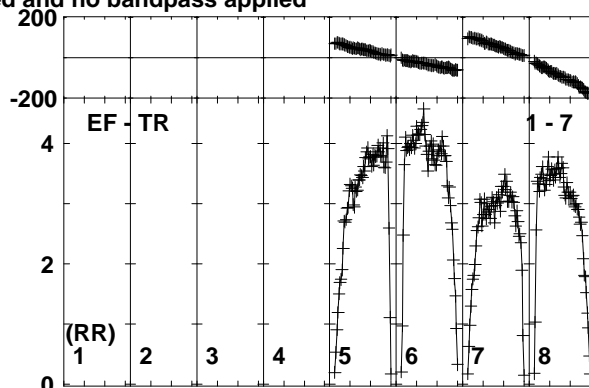
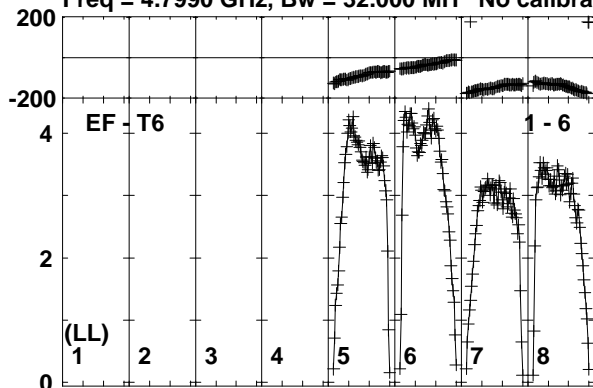

Lower frame: Milli Ampl Jy Top frame: Phas deg
Vector averaged cross-power spectrum Baseline: EF (01) - T6 (06)
Timerange: 00/07:25:10 to 00/07:26:39

Plot file version 67 created 03-OCT-2017 13:27:26

ARUMA EG096C.UVDATA.1

Freq = 4.7990 GHz, Bw = 32.000 MH No calibration applied and no bandpass applied

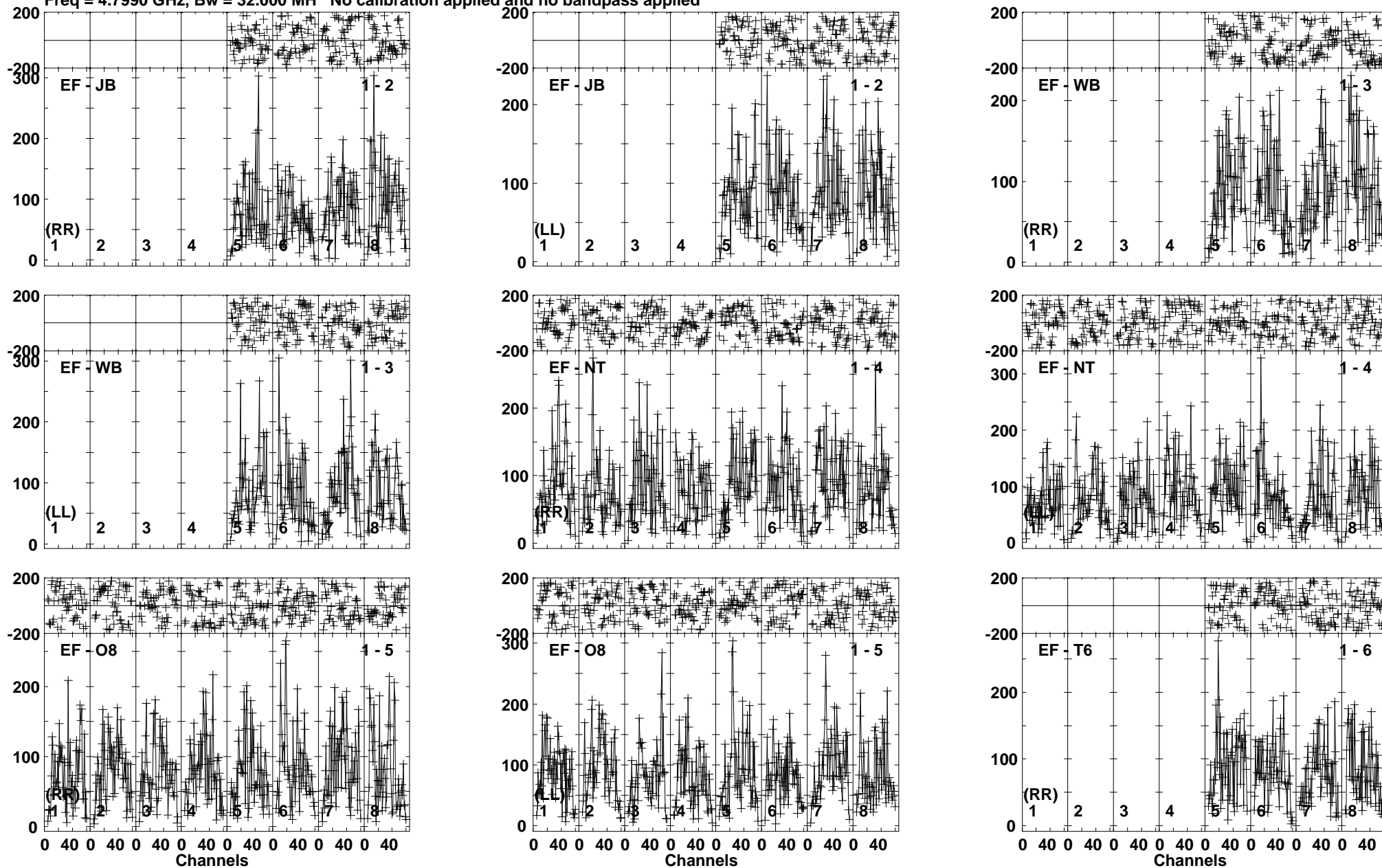

Lower frame: Micro Ampl Jy Top frame: Phas deg
Vector averaged cross-power spectrum Baseline: EF (01) - JB (02)
Timerange: 00/07:26:40 to 00/07:30:09

Plot file version 68 created 03-OCT-2017 13:27:27

ARUMA EG096C.UVDATA.1

Freq = 4.7990 GHz, Bw = 32.000 MH No calibration applied and no bandpass applied

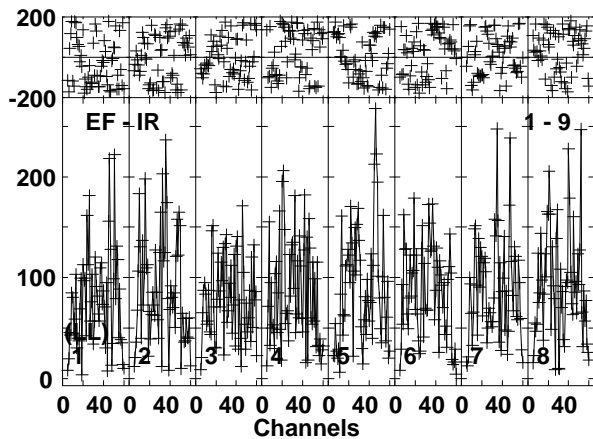
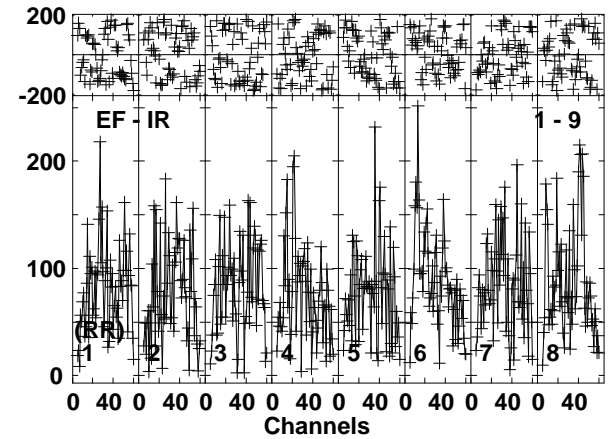
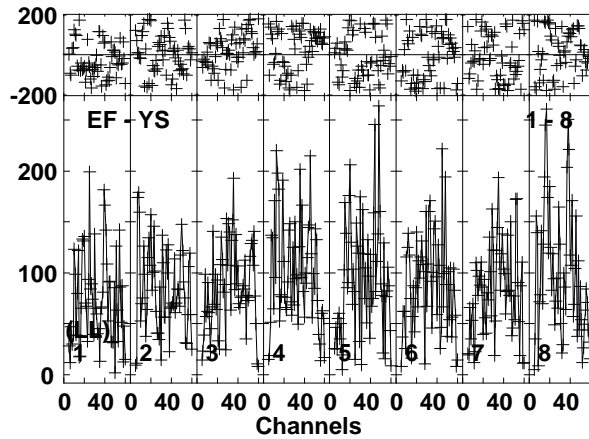
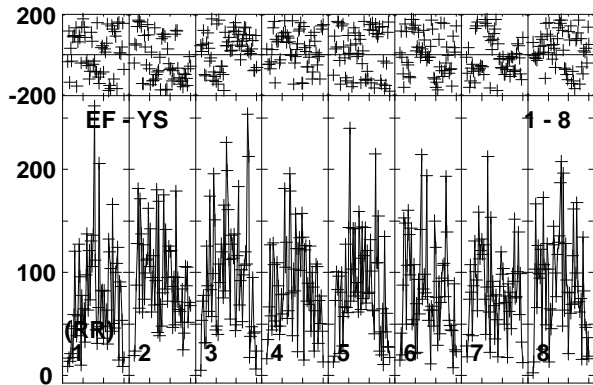
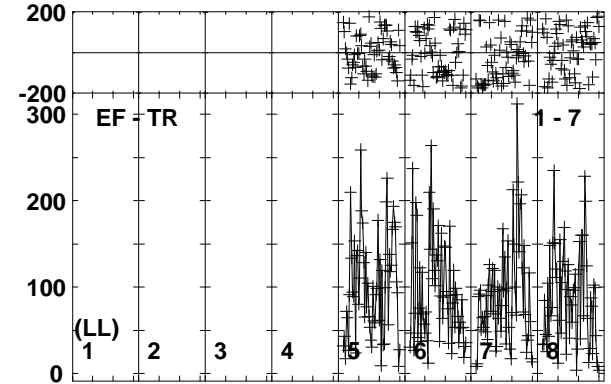
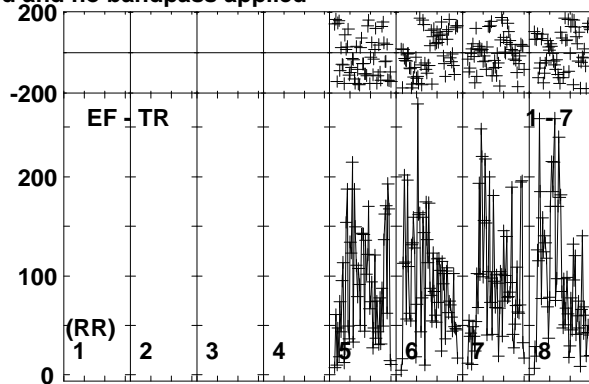
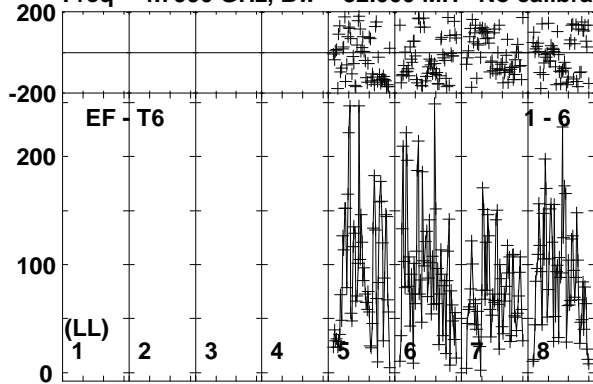

Lower frame: Micro Ampl Jy Top frame: Phas deg
Vector averaged cross-power spectrum Baseline: EF (01) - T6 (06)
Timerange: 00/07:26:40 to 00/07:30:09

Plot file version 69 created 03-OCT-2017 13:27:27

J1108+4330 EG096C.UVDATA.1

Freq = 4.7990 GHz, Bw = 32.000 MH No calibration applied and no bandpass applied

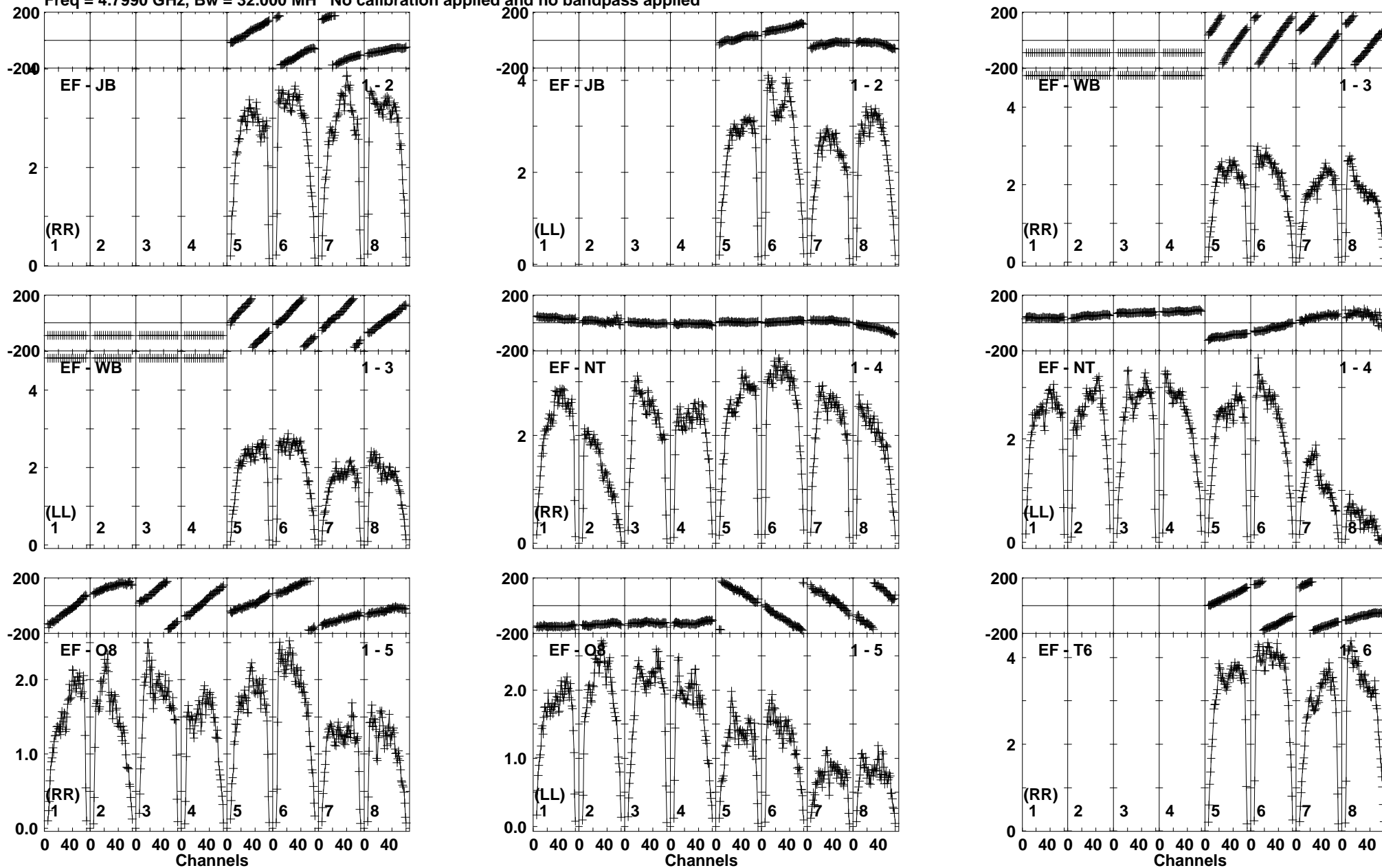

Lower frame: Milli Ampl Jy Top frame: Phas deg
Vector averaged cross-power spectrum Baseline: EF (01) - JB (02)
Timerange: 00/07:30:50 to 00/07:31:48

Plot file version 70 created 03-OCT-2017 13:27:27

J1108+4330 EG096C.UVDATA.1

Freq = 4.7990 GHz, Bw = 32.000 MH No calibration applied and no bandpass applied

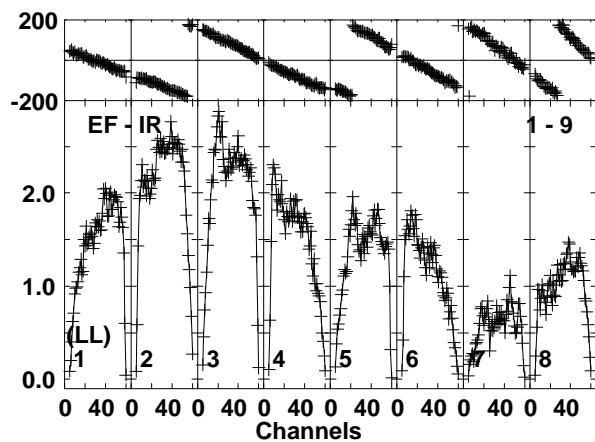
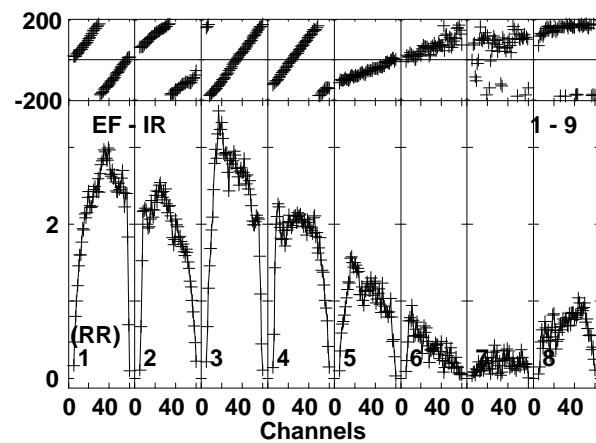
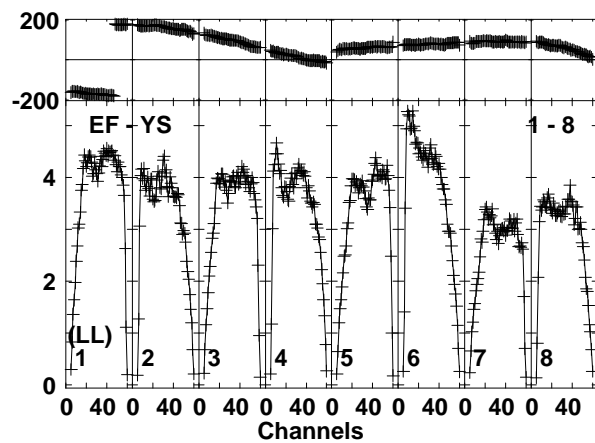
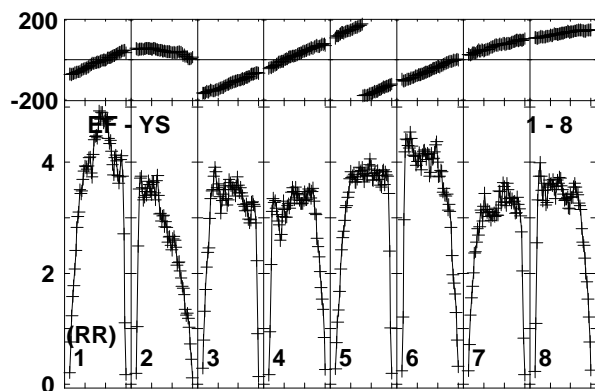
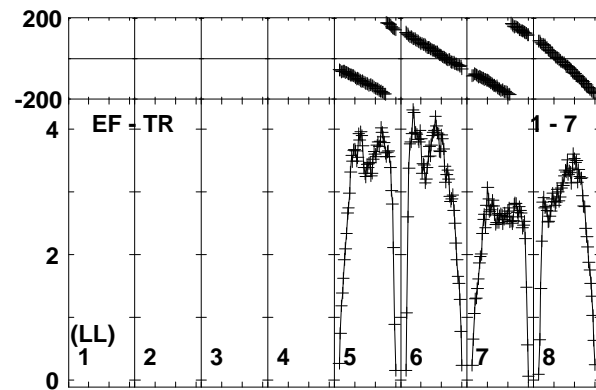
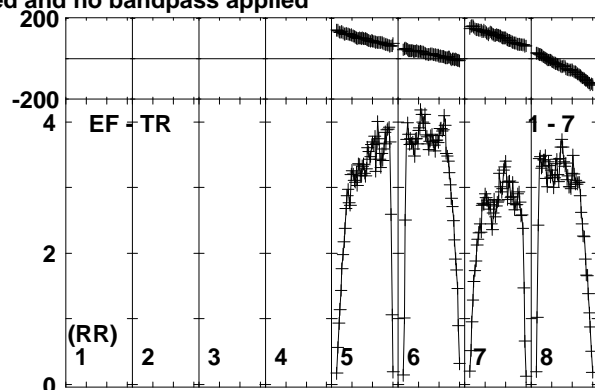
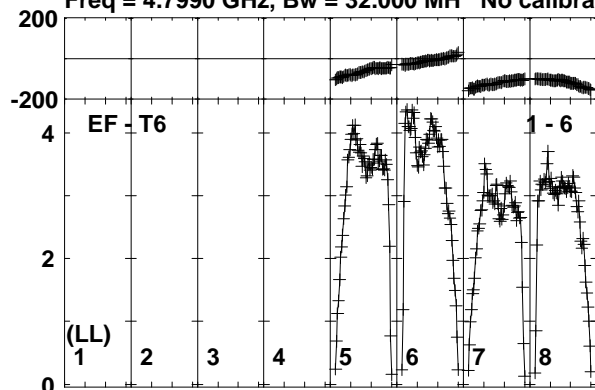

Lower frame: Milli Ampl Jy Top frame: Phas deg
Vector averaged cross-power spectrum Baseline: EF (01) - T6 (06)
Timerange: 00/07:30:50 to 00/07:31:48

Plot file version 71 created 03-OCT-2017 13:27:27

ARUMA EG096C.UVDATA.1

Freq = 4.7990 GHz, Bw = 32.000 MH No calibration applied and no bandpass applied

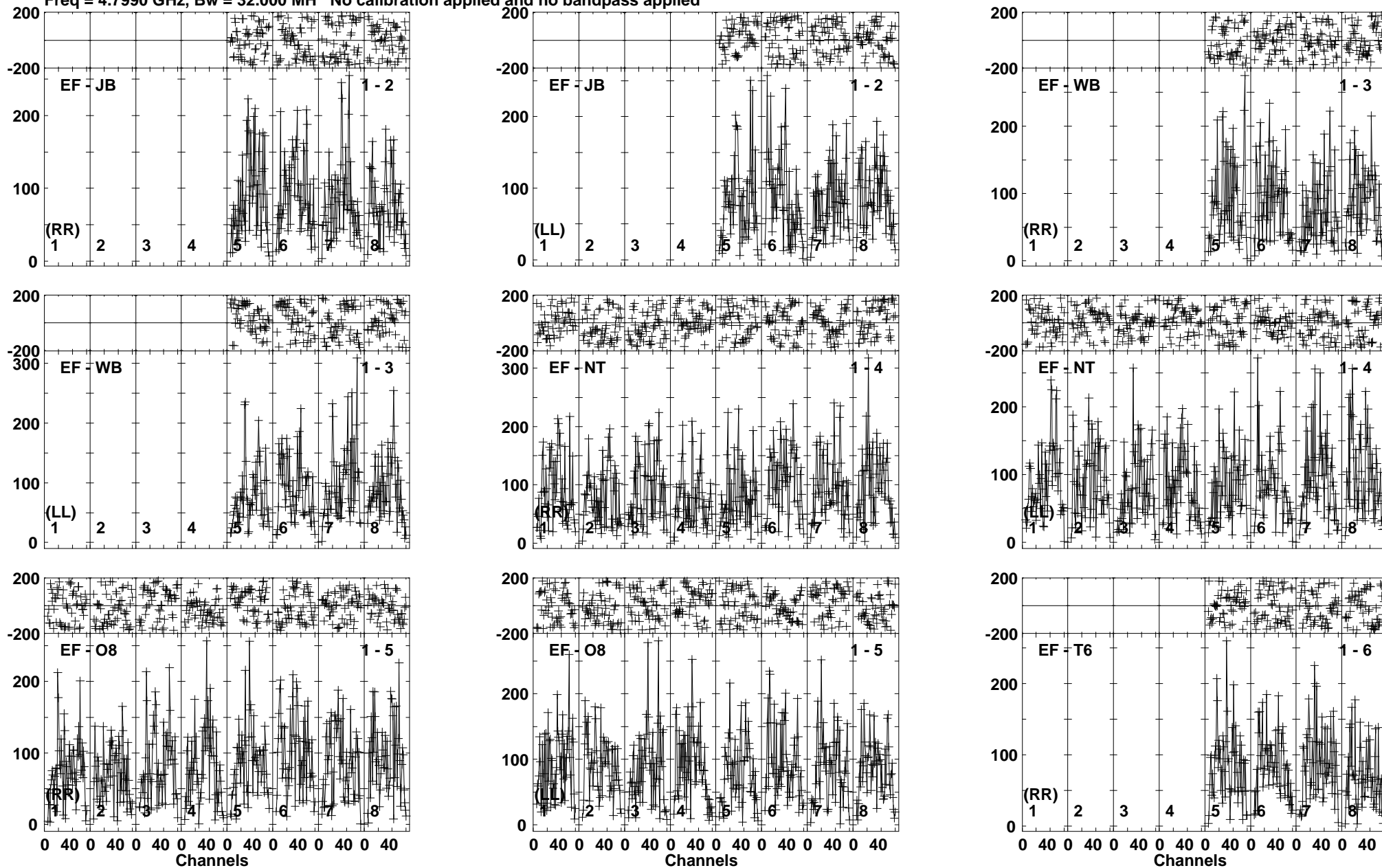

Lower frame: Micro Ampl Jy Top frame: Phas deg
Vector averaged cross-power spectrum Baseline: EF (01) - JB (02)
Timerange: 00/07:31:50 to 00/07:35:19

Plot file version 72 created 03-OCT-2017 13:27:28

ARUMA EG096C.UVDATA.1

Freq = 4.7990 GHz, Bw = 32.000 MH No calibration applied and no bandpass applied

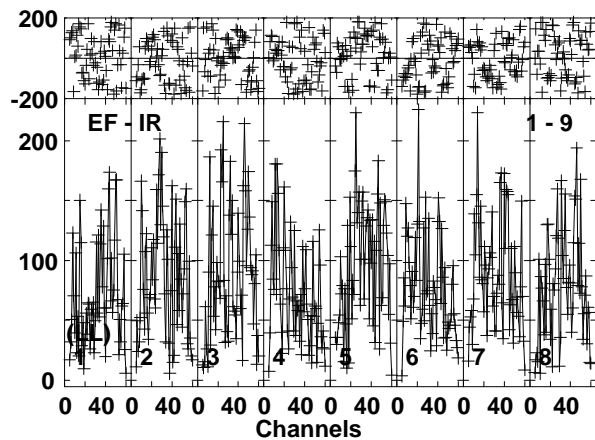
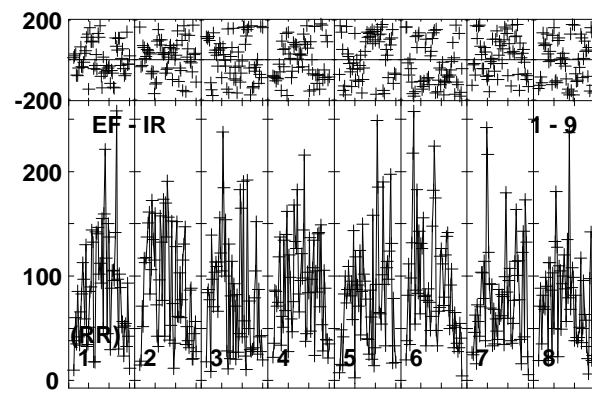
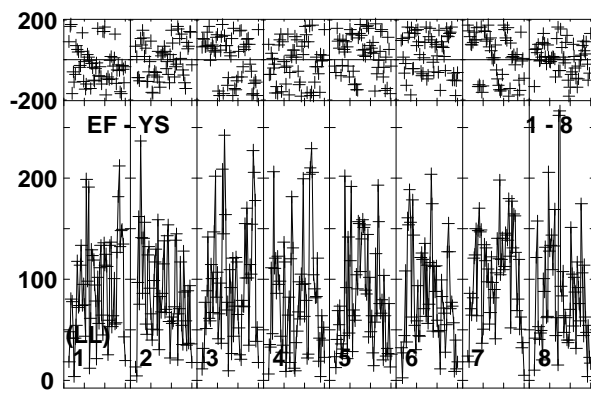
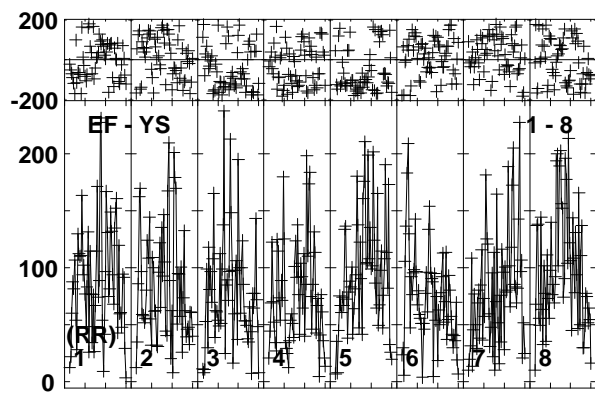
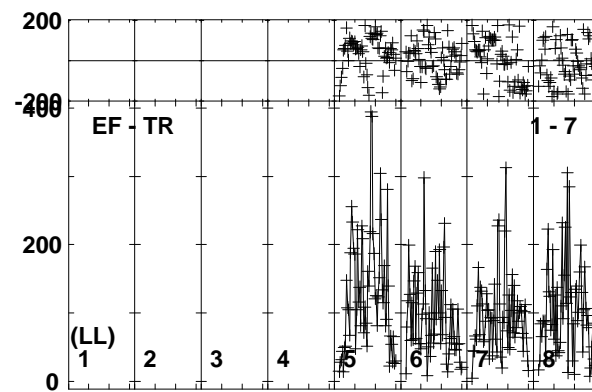
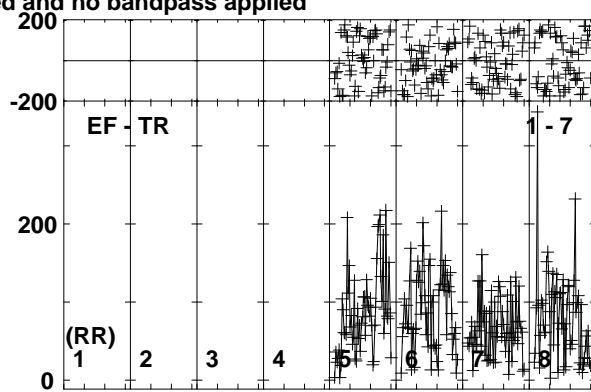
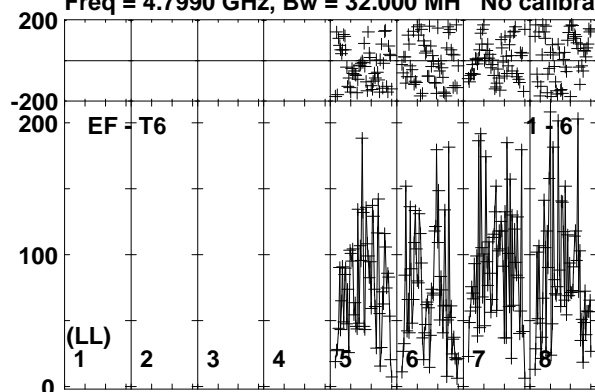

Lower frame: Micro Ampl Jy Top frame: Phas deg
Vector averaged cross-power spectrum Baseline: EF (01) - T6 (06)
Timerange: 00/07:31:50 to 00/07:35:19

Plot file version 73 created 03-OCT-2017 13:27:28

J1108+4330 EG096C.UVDATA.1

Freq = 4.7990 GHz, Bw = 32.000 MH No calibration applied and no bandpass applied

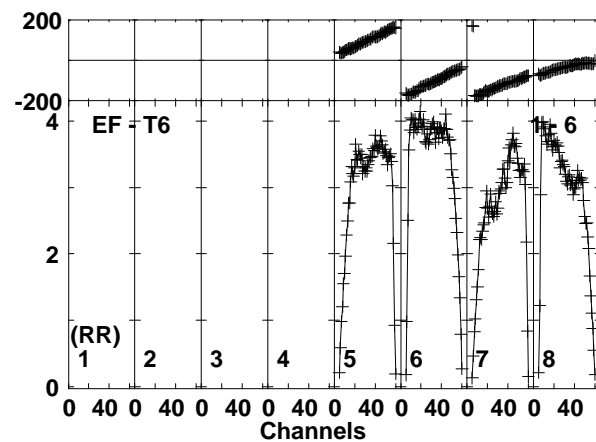
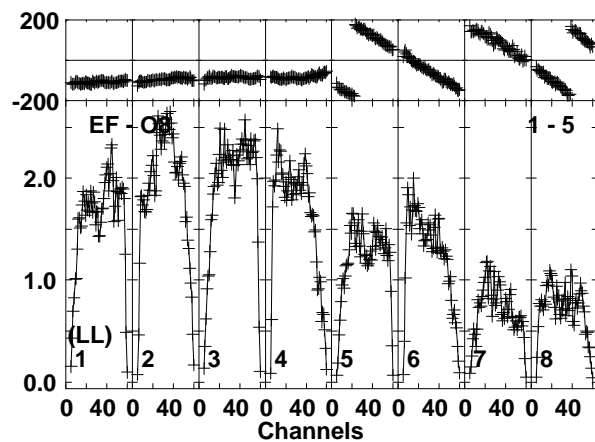
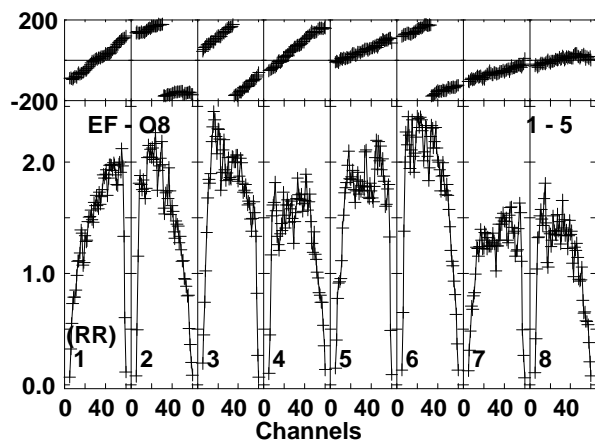
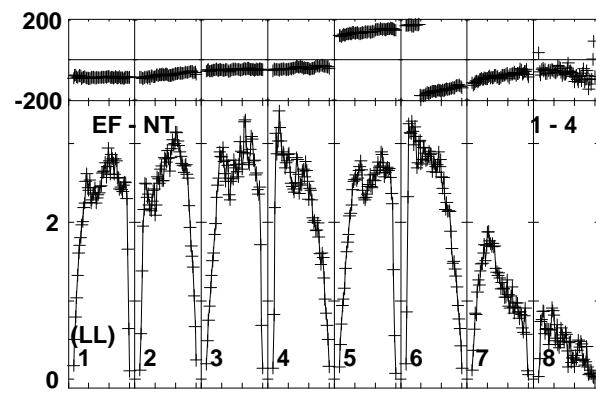
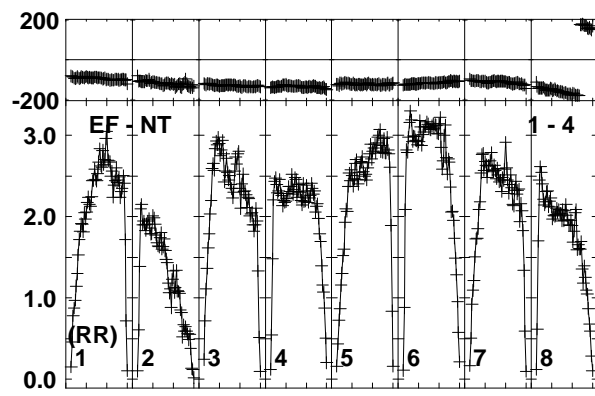
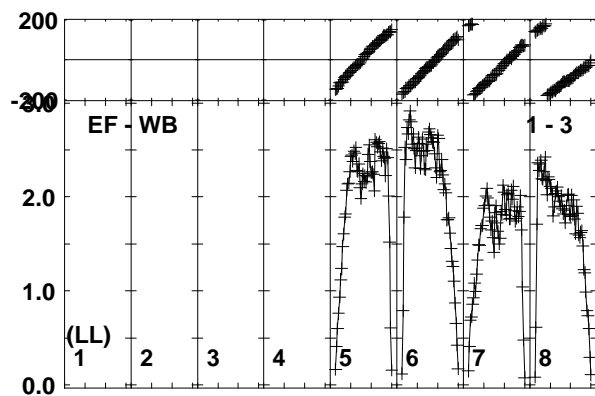
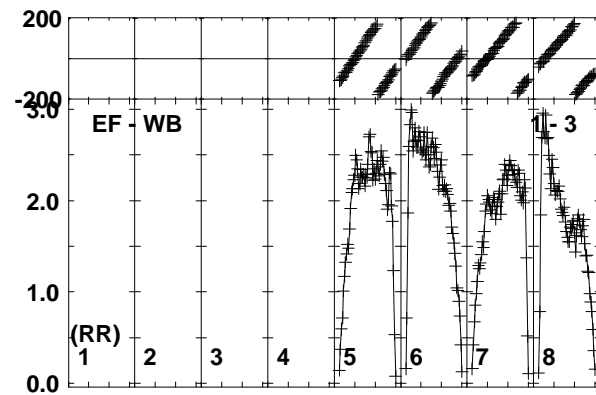
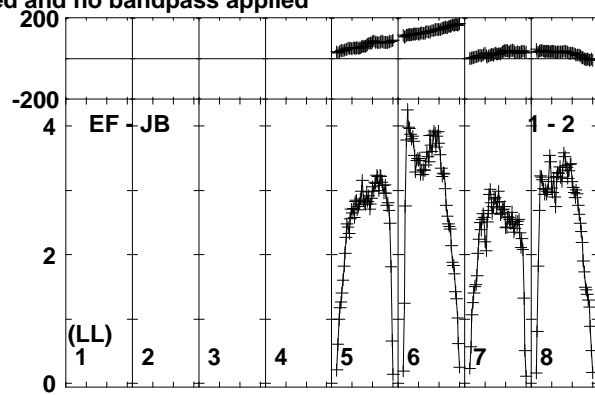
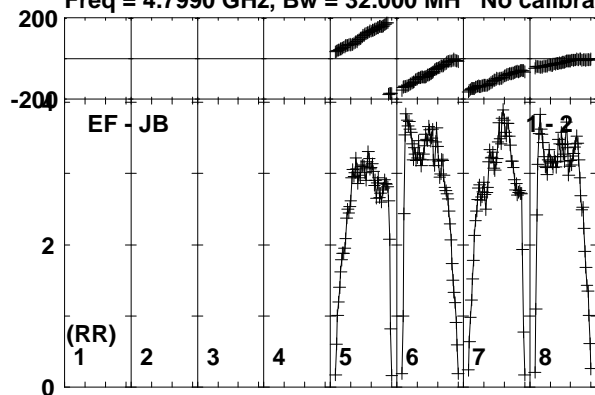

Lower frame: Milli Ampl Jy Top frame: Phas deg
Vector averaged cross-power spectrum Baseline: EF (01) - JB (02)
Timerange: 00/07:35:20 to 00/07:36:49

Plot file version 74 created 03-OCT-2017 13:27:28

J1108+4330 EG096C.UVDATA.1

Freq = 4.7990 GHz, Bw = 32.000 MH No calibration applied and no bandpass applied

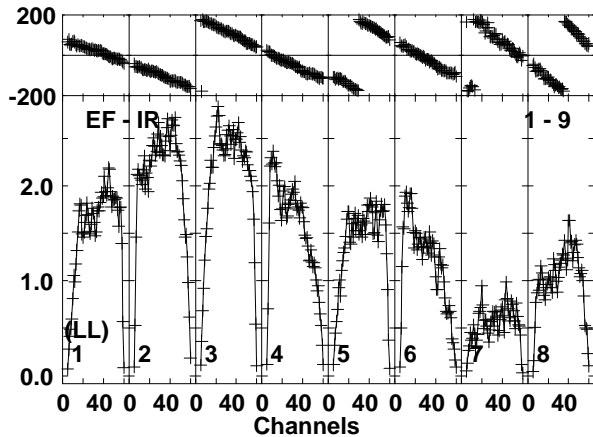
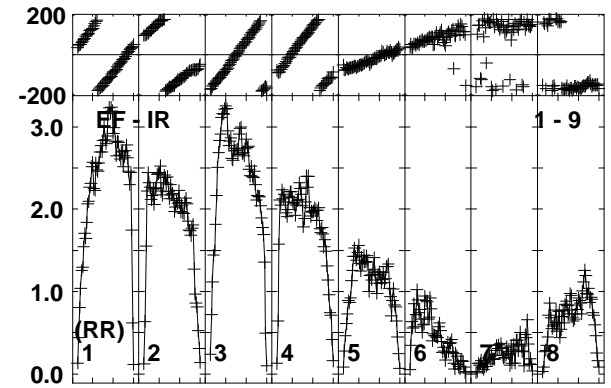
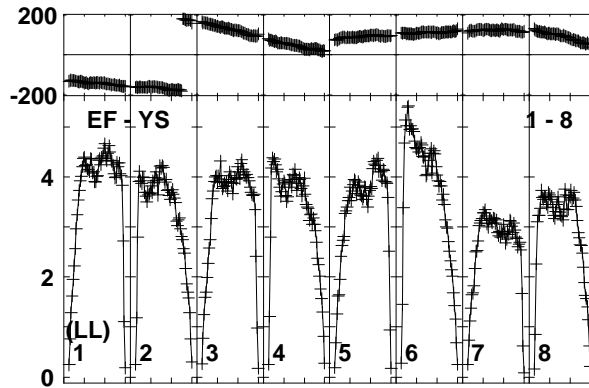
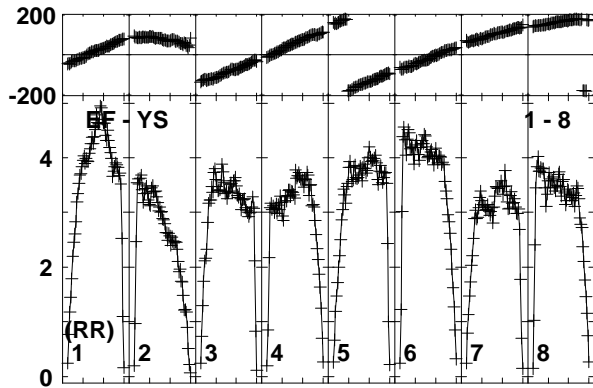
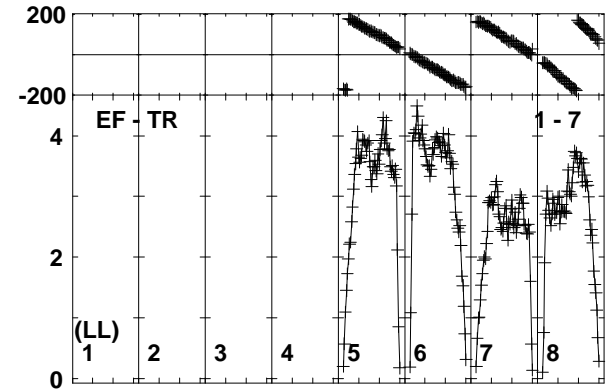
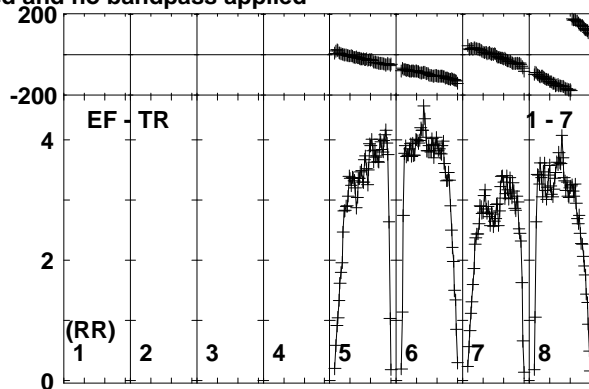
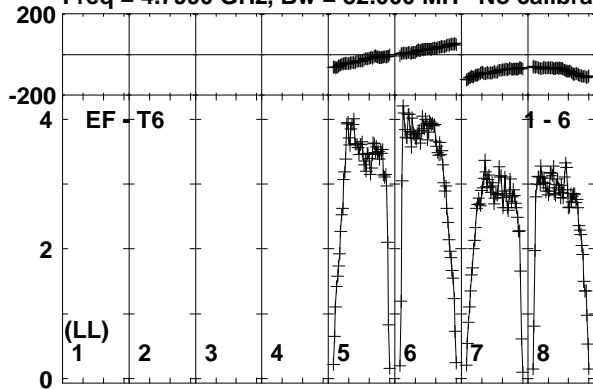

Lower frame: Milli Ampl Jy Top frame: Phas deg
Vector averaged cross-power spectrum Baseline: EF (01) - T6 (06)
Timerange: 00/07:35:20 to 00/07:36:49

Plot file version 75 created 03-OCT-2017 13:27:28

ARUMA EG096C.UVDATA.1

Freq = 4.7990 GHz, Bw = 32.000 MH No calibration applied and no bandpass applied

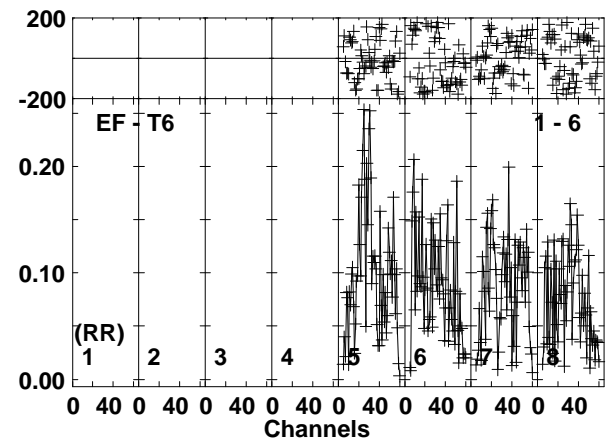
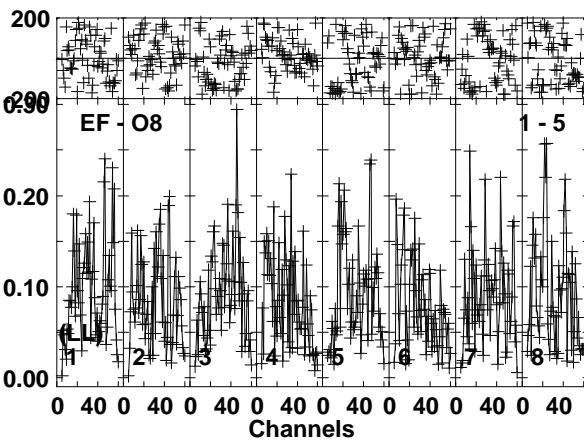
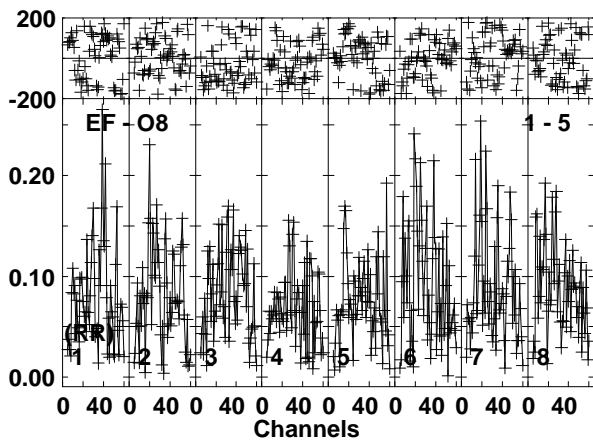
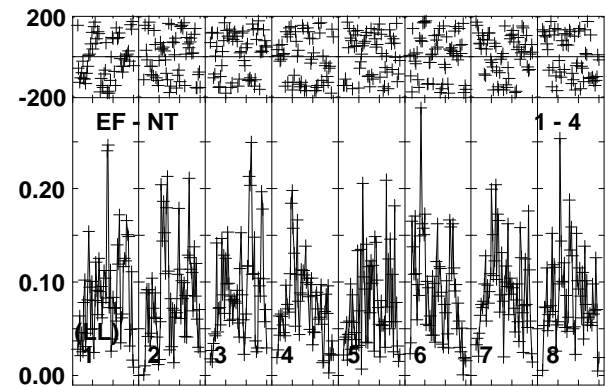
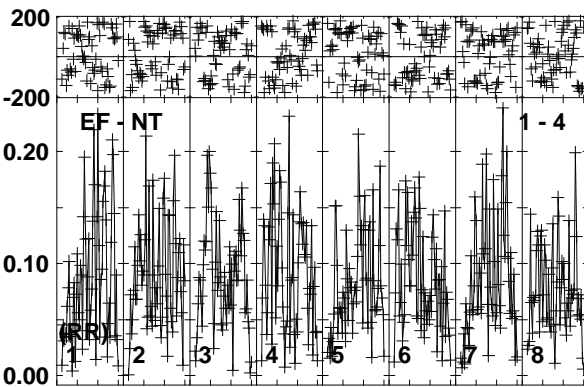
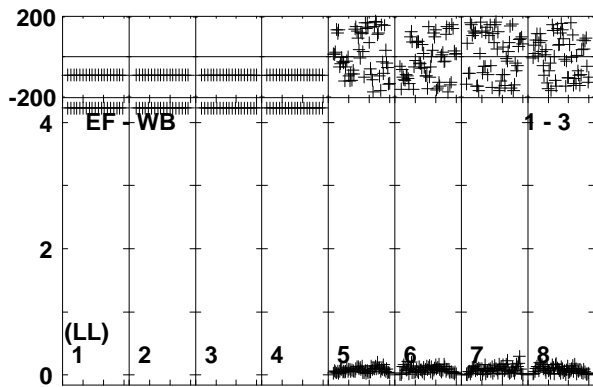
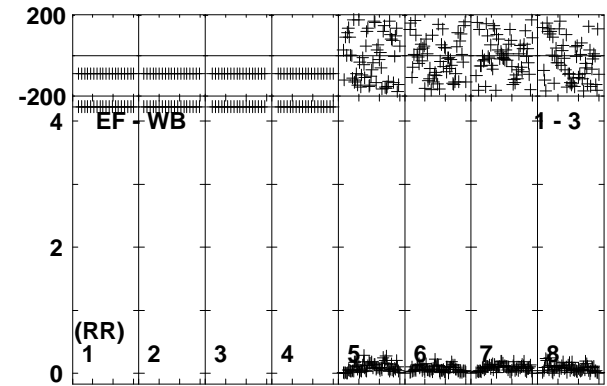
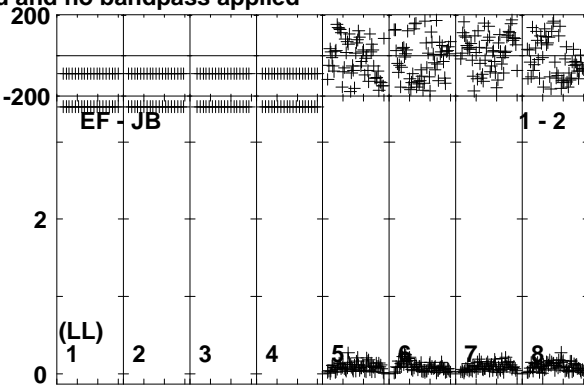
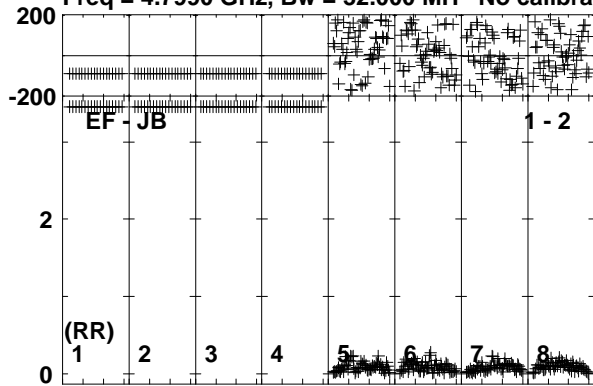

Lower frame: Milli Ampl Jy Top frame: Phas deg
Vector averaged cross-power spectrum Baseline: EF (01) - JB (02)
Timerange: 00/07:36:49 to 00/07:40:19

Plot file version 76 created 03-OCT-2017 13:27:29

ARUMA EG096C.UVDATA.1

Freq = 4.7990 GHz, Bw = 32.000 MH No calibration applied and no bandpass applied

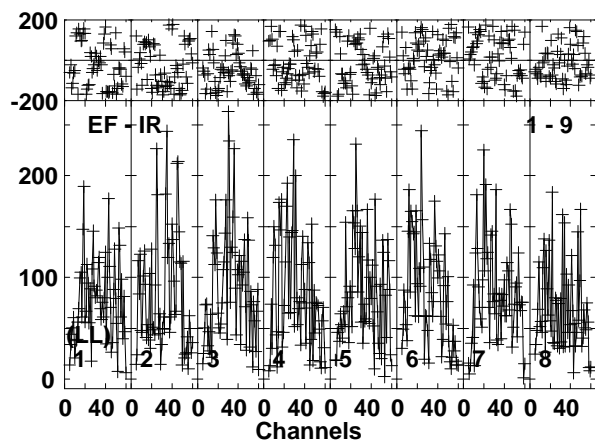
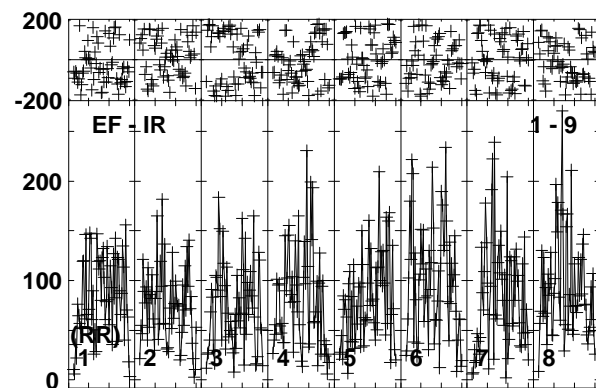
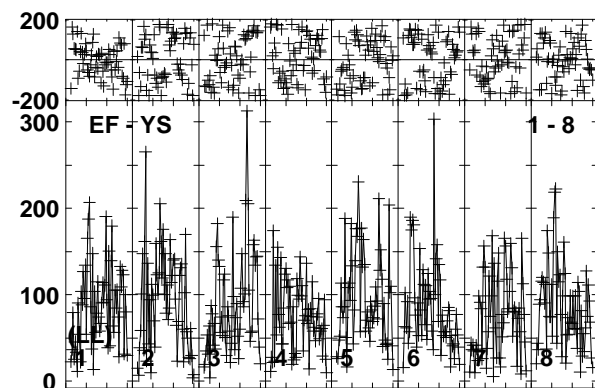
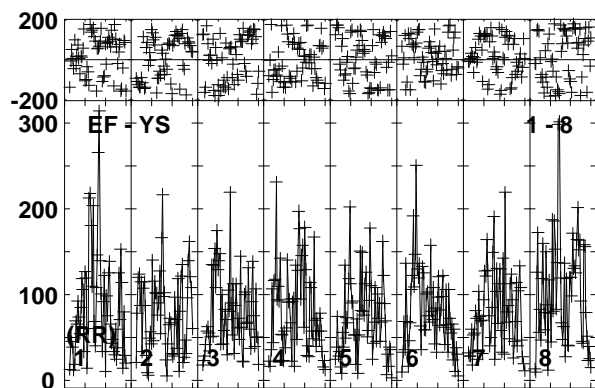
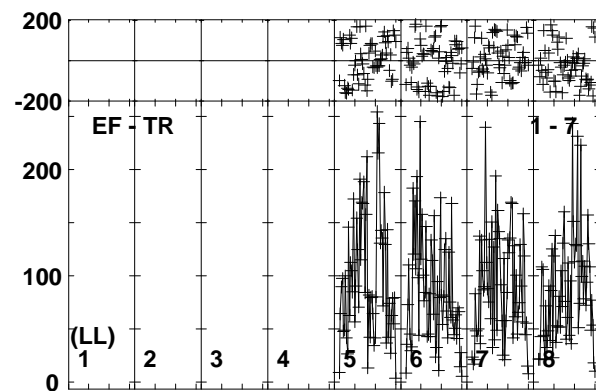
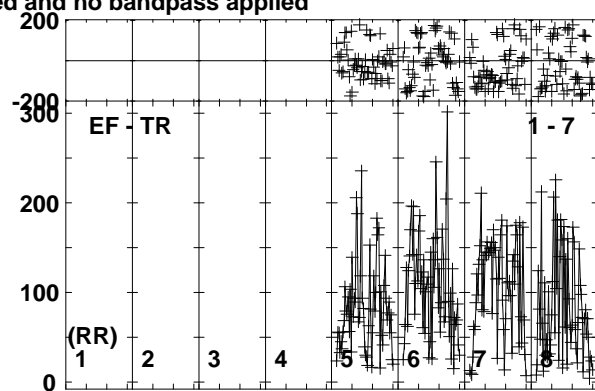
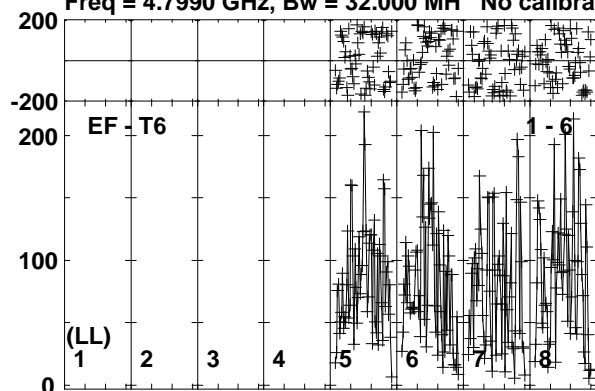

Lower frame: Micro Ampl Jy Top frame: Phas deg
Vector averaged cross-power spectrum Baseline: EF (01) - T6 (06)
Timerange: 00/07:36:49 to 00/07:40:19

Plot file version 77 created 03-OCT-2017 13:27:29

J1108+4330 EG096C.UVDATA.1

Freq = 4.7990 GHz, Bw = 32.000 MH No calibration applied and no bandpass applied

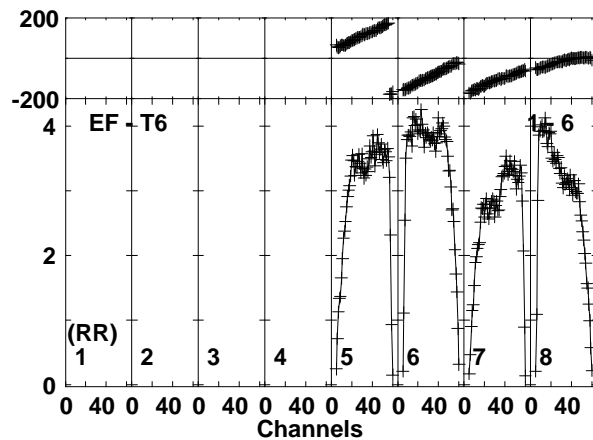
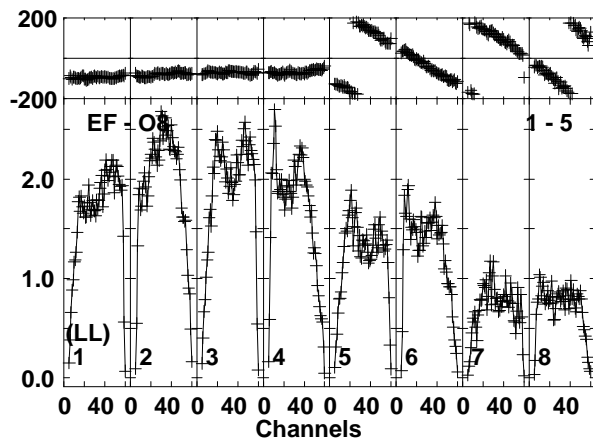
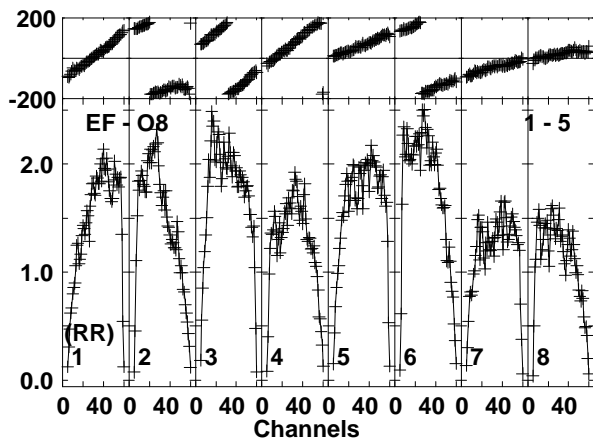
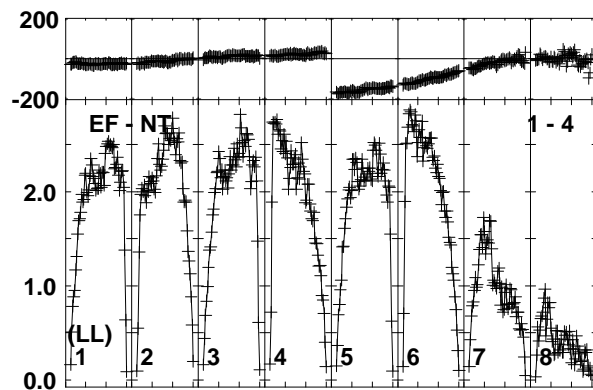
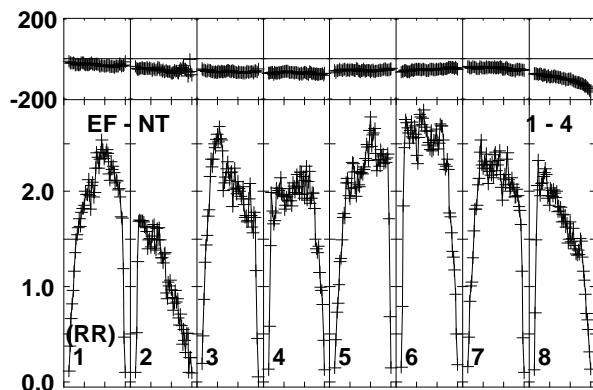
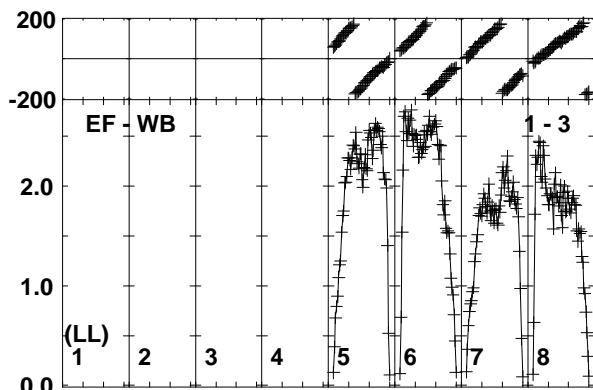
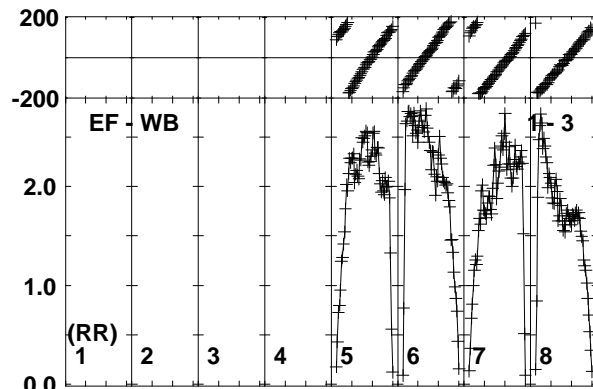
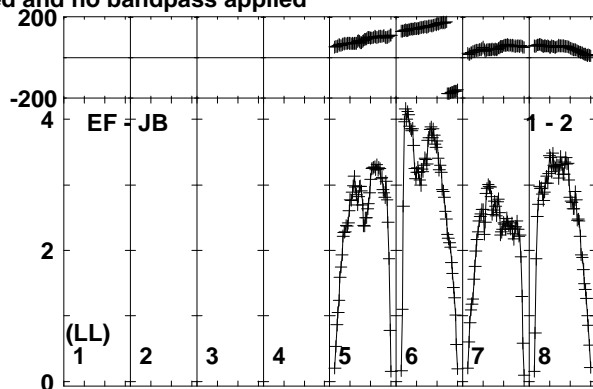
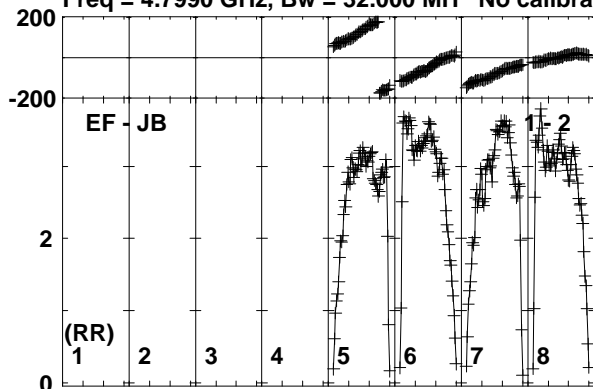

Lower frame: Milli Ampl Jy Top frame: Phas deg
Vector averaged cross-power spectrum Baseline: EF (01) - JB (02)
Timerange: 00/07:40:59 to 00/07:41:59

Plot file version 78 created 03-OCT-2017 13:27:29

J1108+4330 EG096C.UVDATA.1

Freq = 4.7990 GHz, Bw = 32.000 MH No calibration applied and no bandpass applied

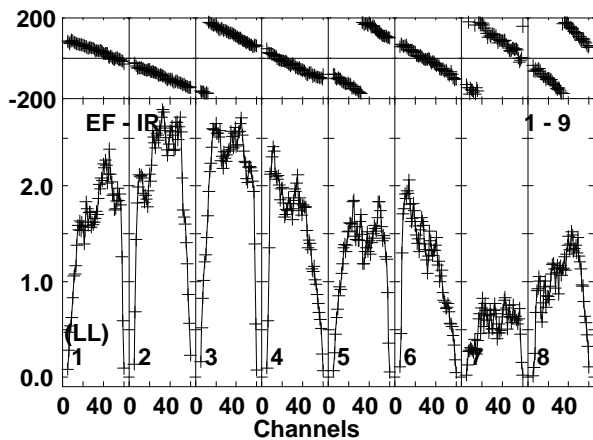
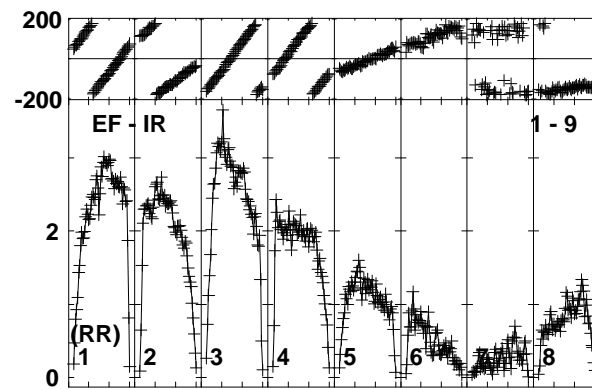
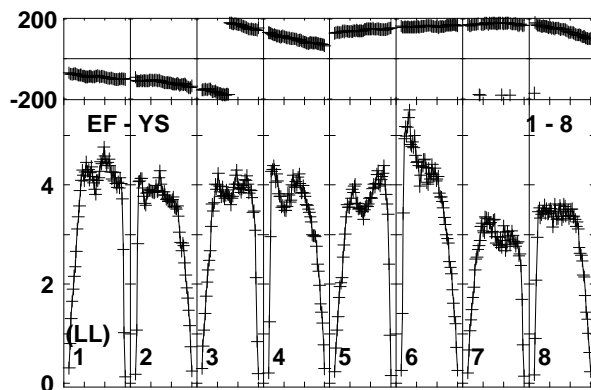
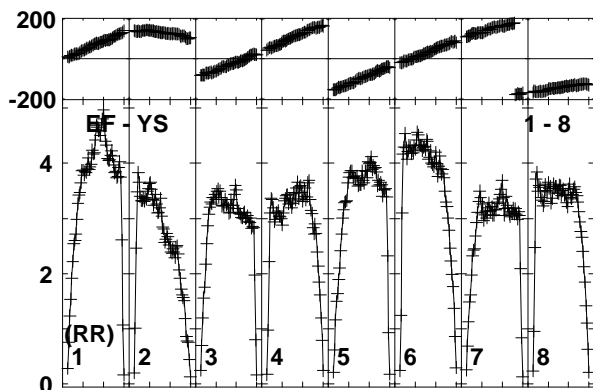
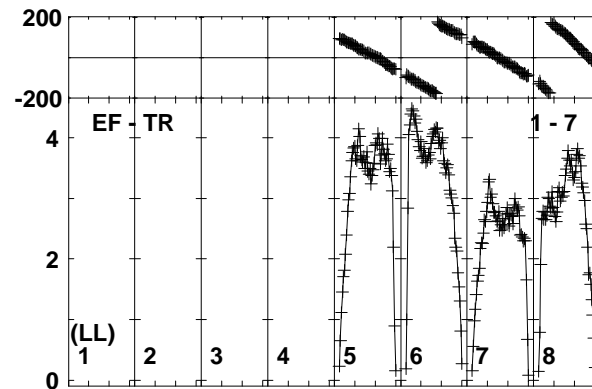
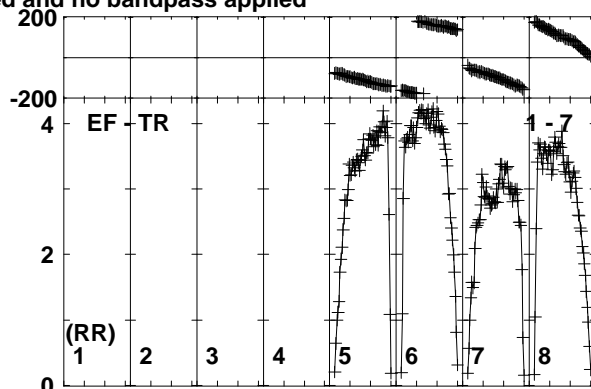
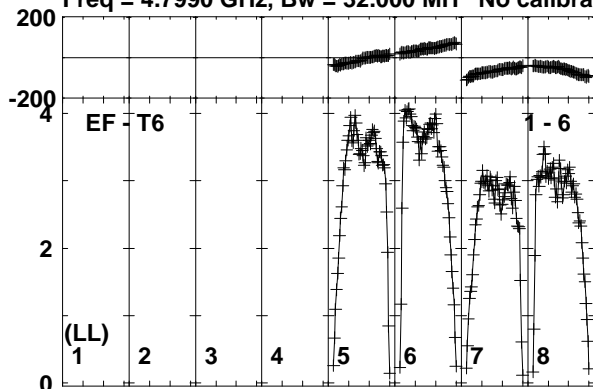

Lower frame: Milli Ampl Jy Top frame: Phas deg
Vector averaged cross-power spectrum Baseline: EF (01) - T6 (06)
Timerange: 00/07:40:59 to 00/07:41:59

Plot file version 79 created 03-OCT-2017 13:27:29

J1112+4301 EG096C.UVDATA.1

Freq = 4.7990 GHz, Bw = 32.000 MH No calibration applied and no bandpass applied

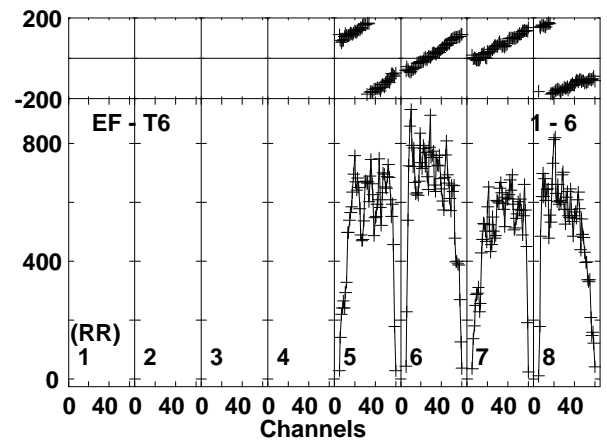
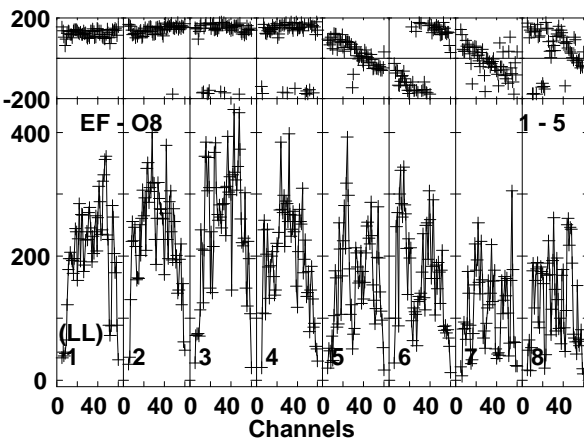
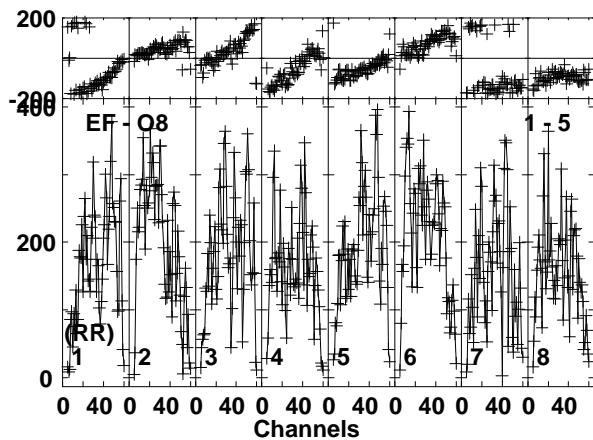
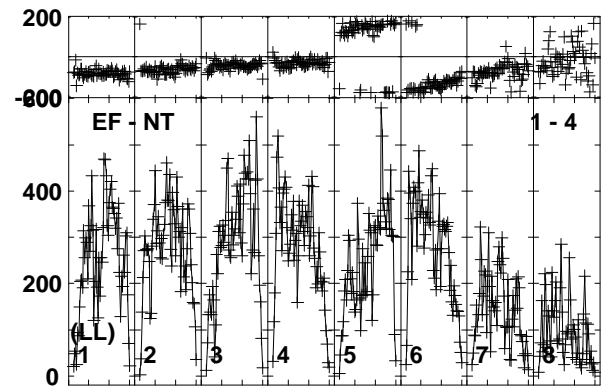
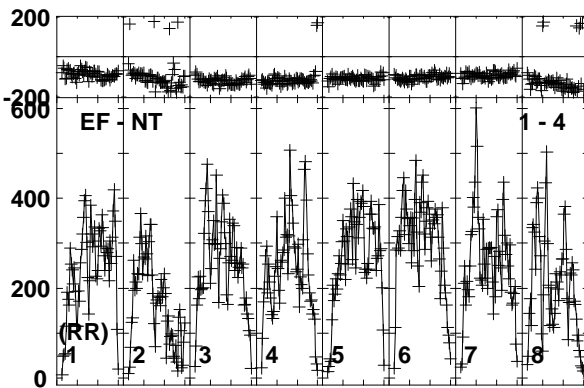
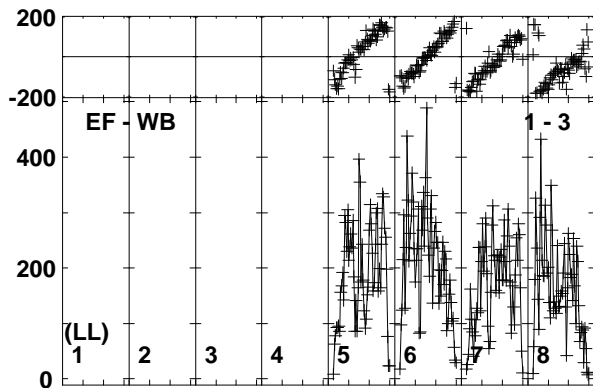
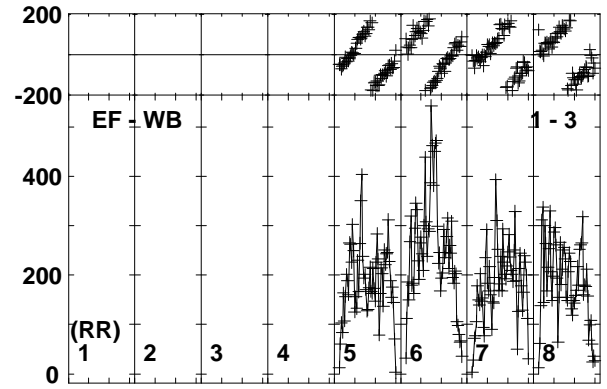
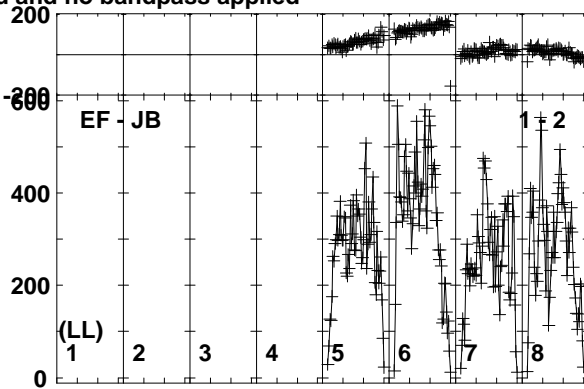
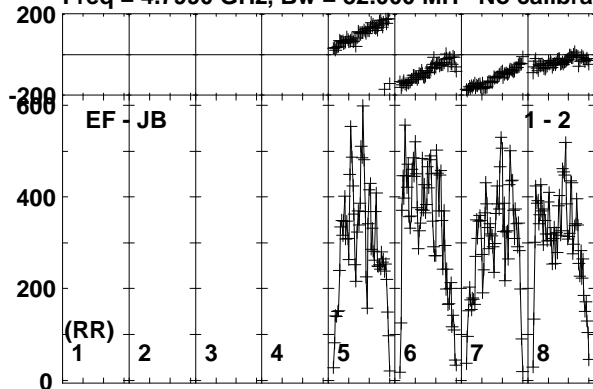

Lower frame: Micro Ampl Jy Top frame: Phas deg
Vector averaged cross-power spectrum Baseline: EF (01) - JB (02)
Timerange: 00/07:41:59 to 00/07:45:29

Plot file version 80 created 03-OCT-2017 13:27:30

J1112+4301 EG096C.UVDATA.1

Freq = 4.7990 GHz, Bw = 32.000 MH No calibration applied and no bandpass applied

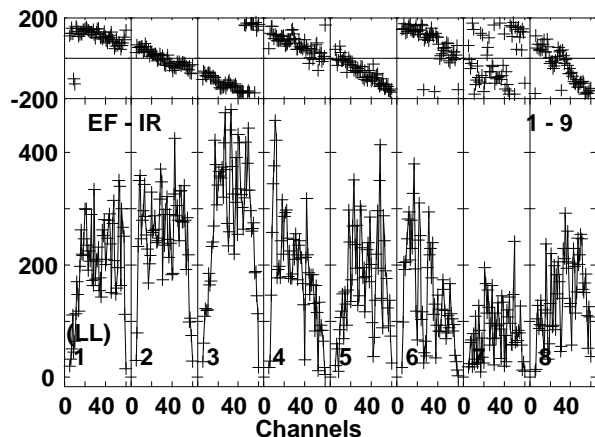
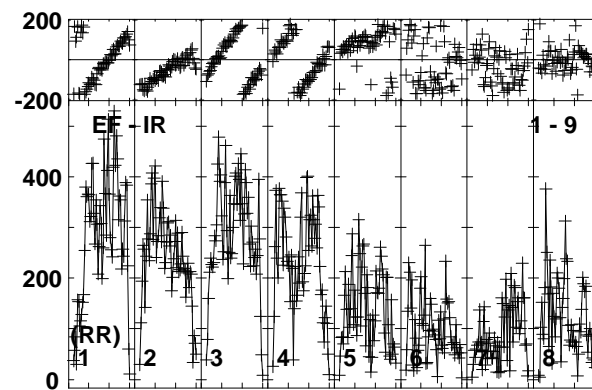
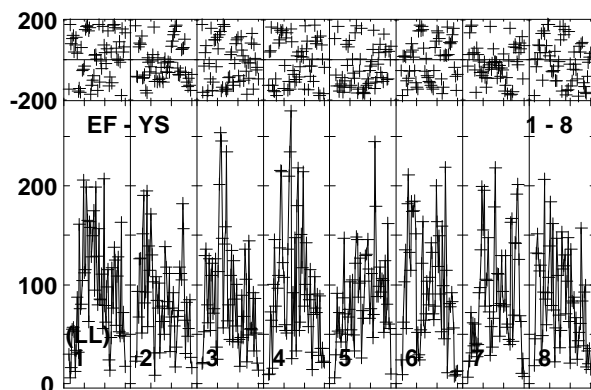
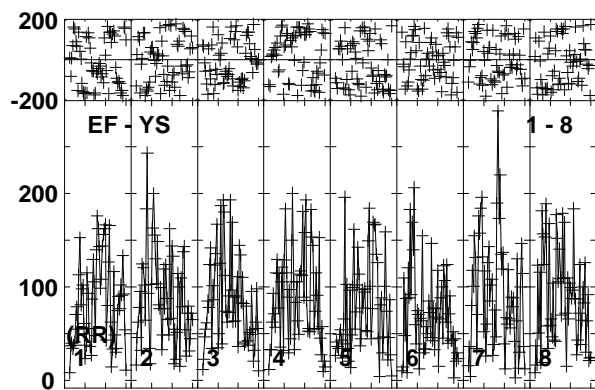
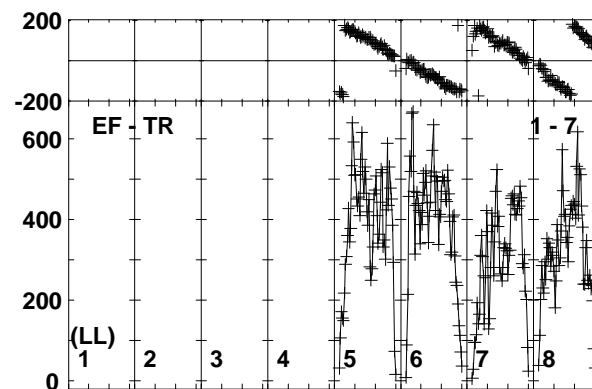
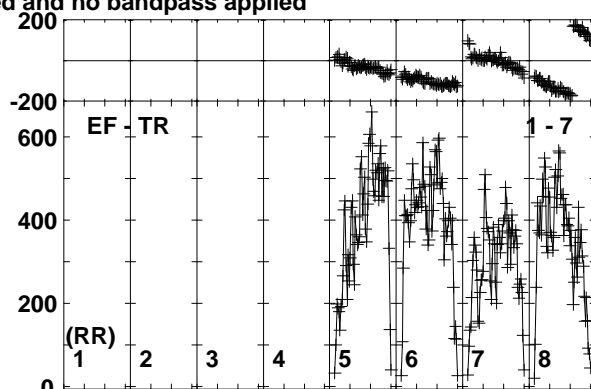
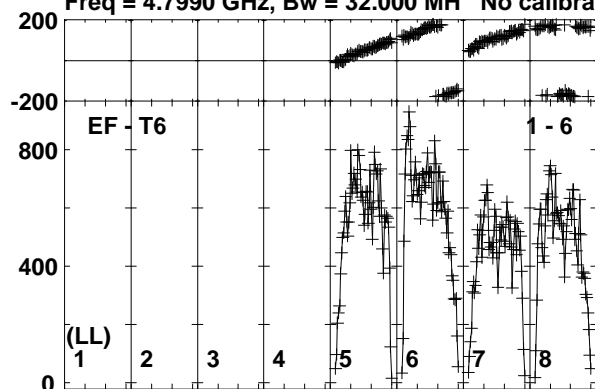

Lower frame: Micro Ampl Jy Top frame: Phas deg
Vector averaged cross-power spectrum Baseline: EF (01) - T6 (06)
Timerange: 00/07:41:59 to 00/07:45:29

Plot file version 81 created 03-OCT-2017 13:27:30

J1108+4330 EG096C.UVDATA.1

Freq = 4.7990 GHz, Bw = 32.000 MH No calibration applied and no bandpass applied

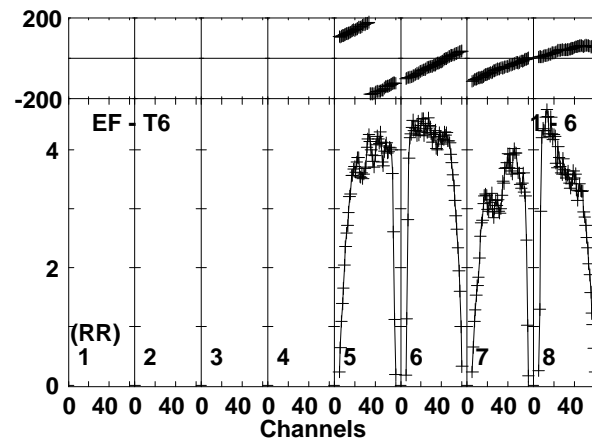
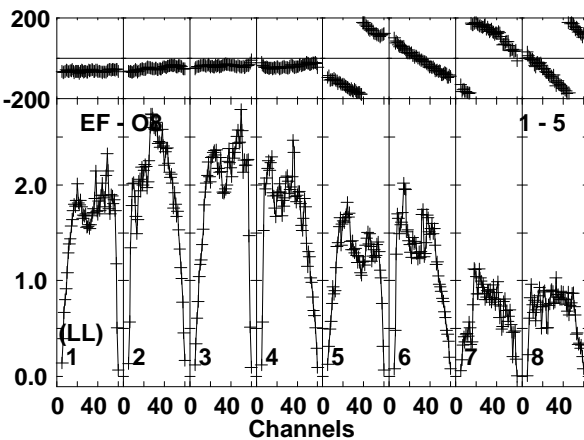
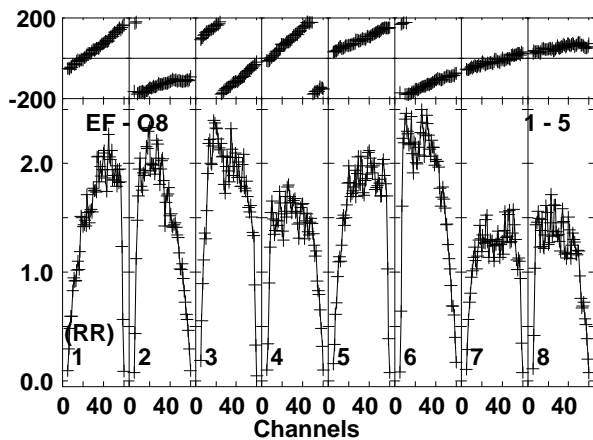
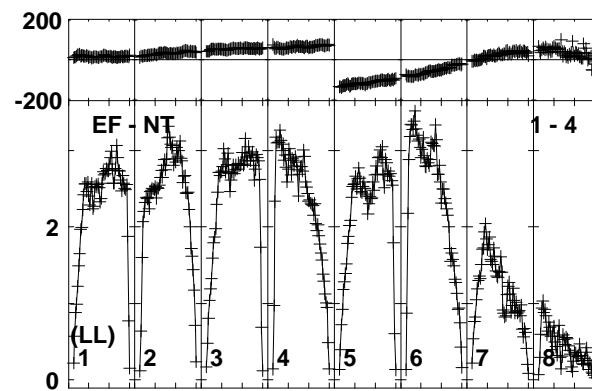
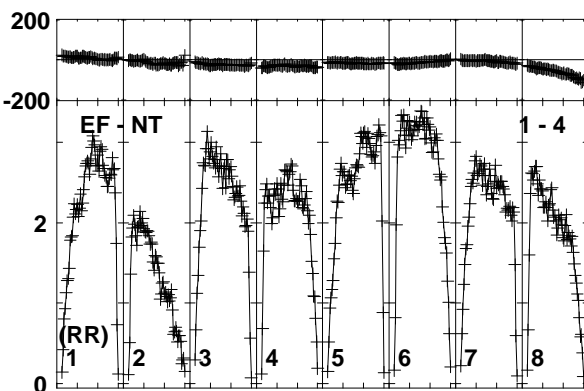
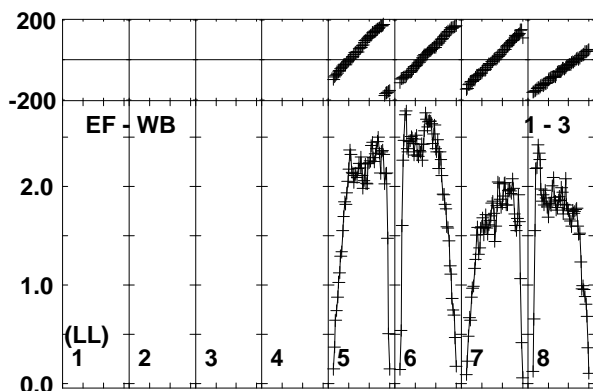
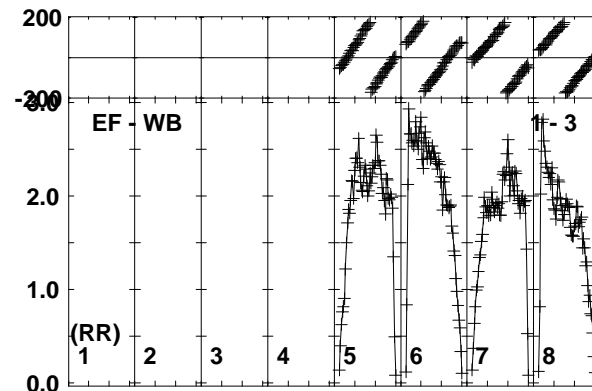
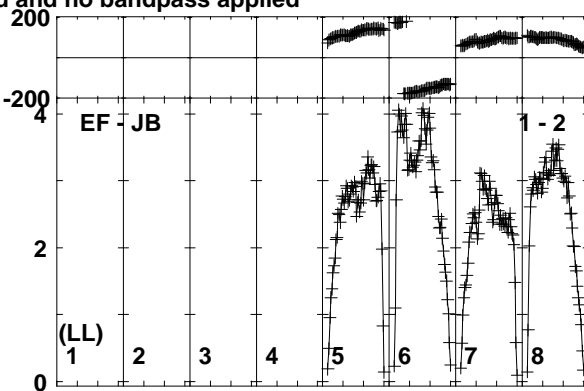
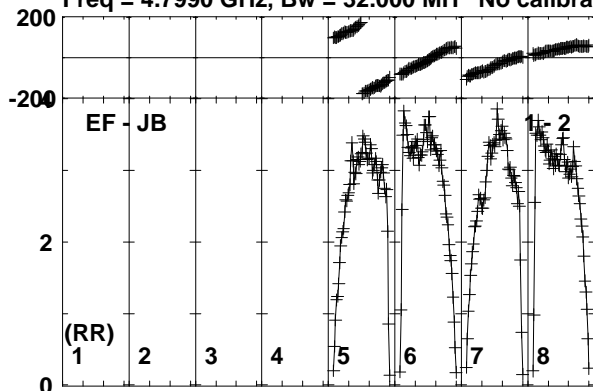

Lower frame: Milli Ampl Jy Top frame: Phas deg
Vector averaged cross-power spectrum Baseline: EF (01) - JB (02)
Timerange: 00/07:45:30 to 00/07:46:58

Plot file version 82 created 03-OCT-2017 13:27:30

J1108+4330 EG096C.UVDATA.1

Freq = 4.7990 GHz, Bw = 32.000 MH No calibration applied and no bandpass applied

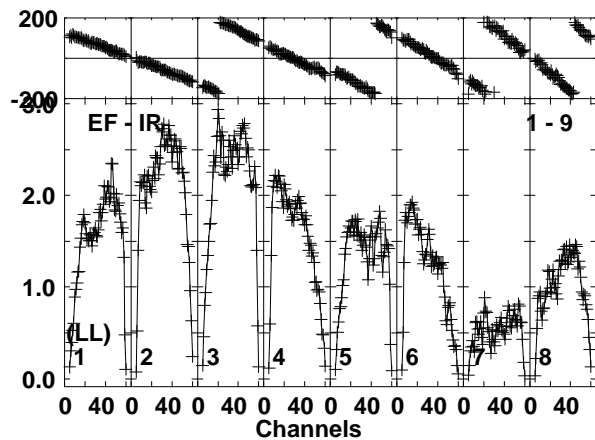
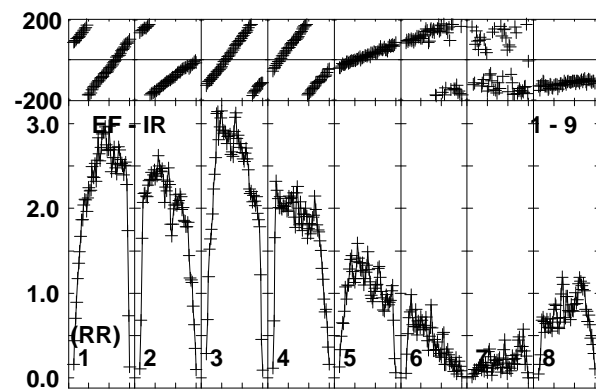
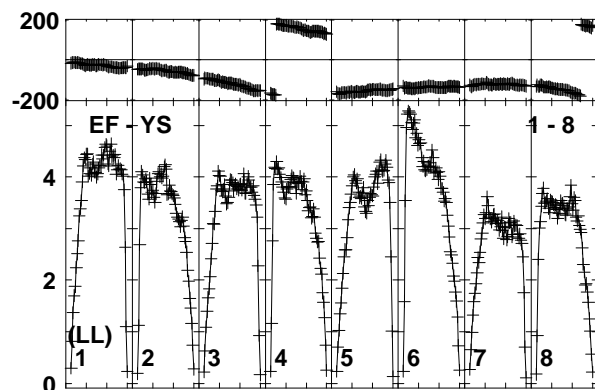
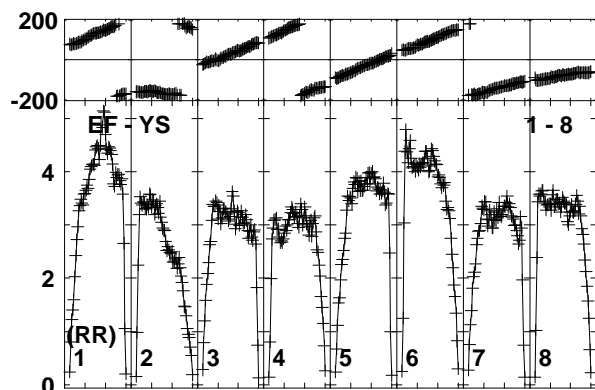
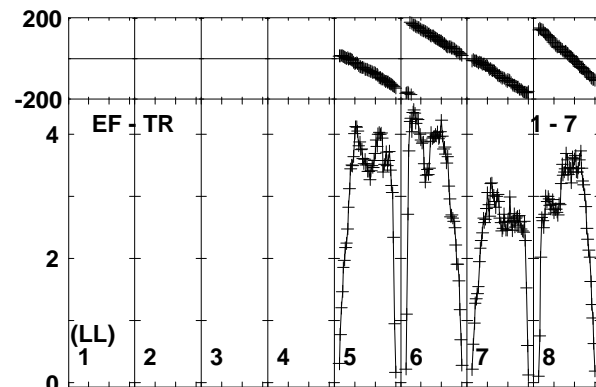
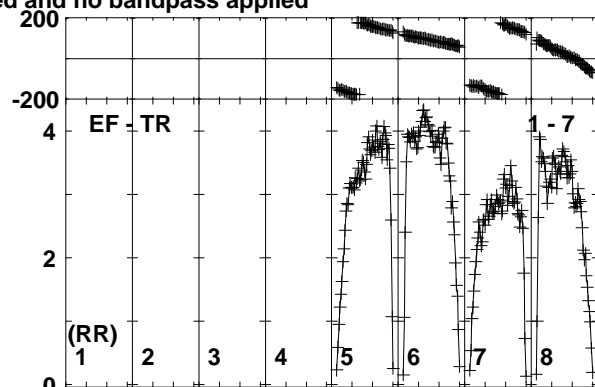
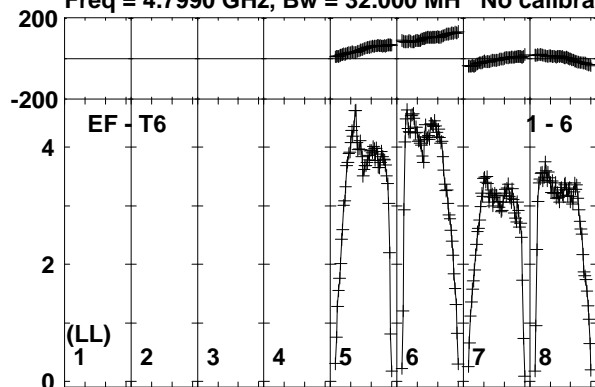

Lower frame: Milli Ampl Jy Top frame: Phas deg
Vector averaged cross-power spectrum Baseline: EF (01) - T6 (06)
Timerange: 00/07:45:30 to 00/07:46:58

Plot file version 83 created 03-OCT-2017 13:27:30
 ARUMA EG096C.UVDATA.1
 Freq = 4.7990 GHz, Bw = 32.000 MH No calibration applied and no bandpass applied

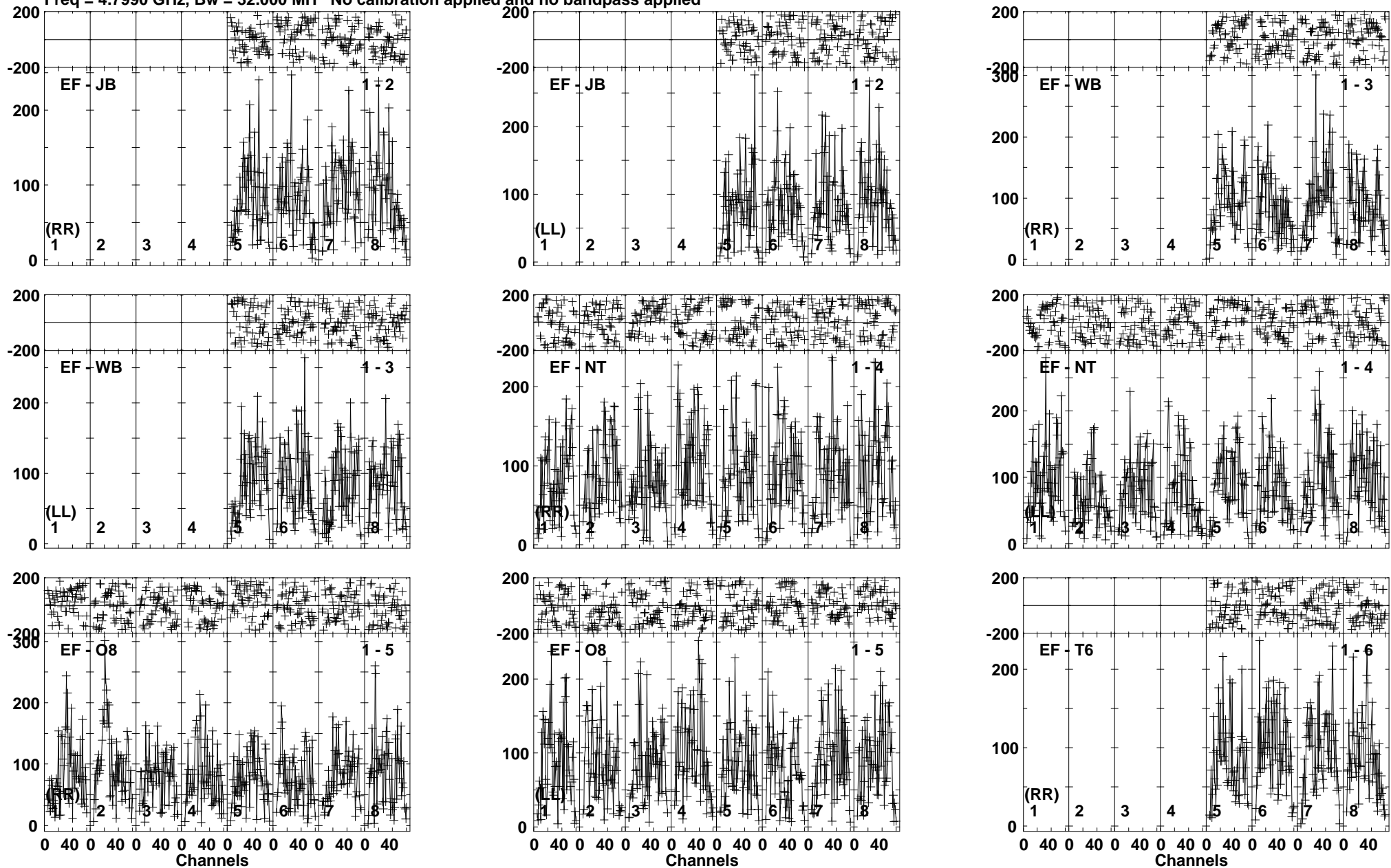

Lower frame: Micro Ampl Jy Top frame: Phas deg
 Vector averaged cross-power spectrum Baseline: EF (01) - JB (02)
 Timerange: 00/07:46:59 to 00/07:50:28

Plot file version 84 created 03-OCT-2017 13:27:31

ARUMA EG096C.UVDATA.1

Freq = 4.7990 GHz, Bw = 32.000 MH No calibration applied and no bandpass applied

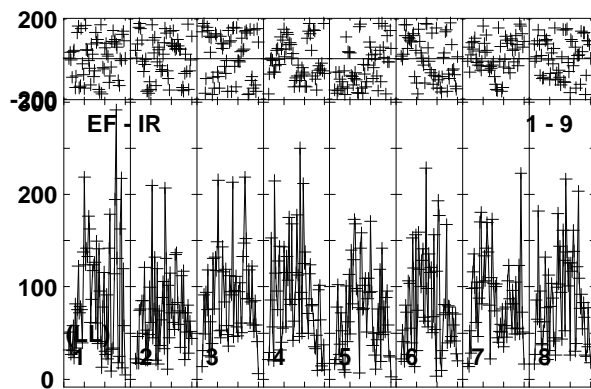
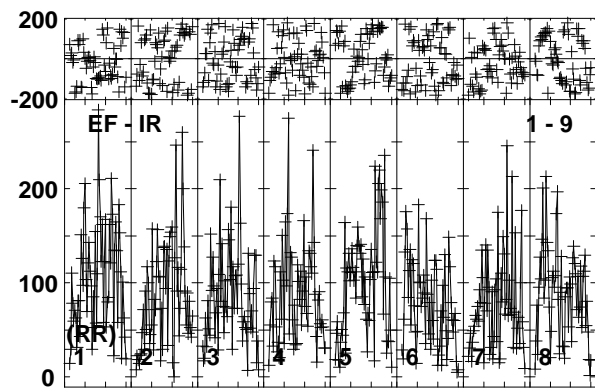
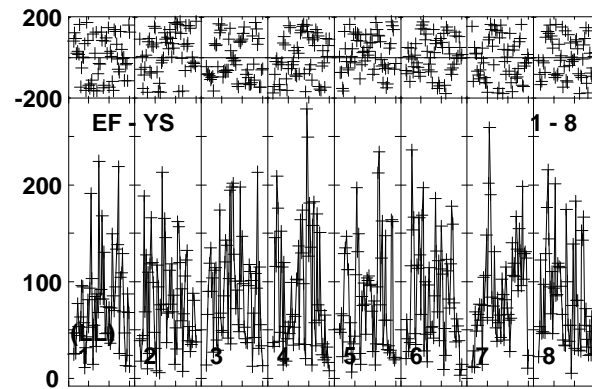
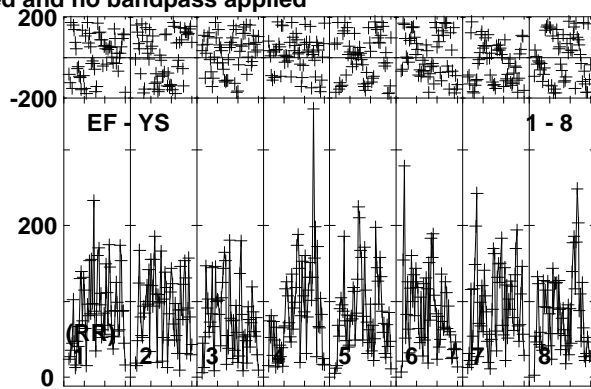
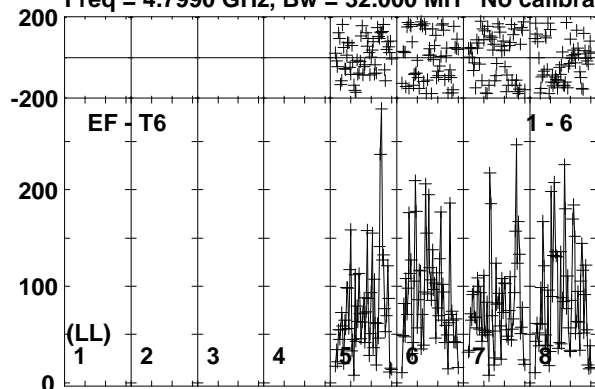

0 40 0 40 0 40 0 40 0 40 0 40 0 40 0 40 0 40
Channels

Lower frame: Micro Ampl Jy Top frame: Phas deg
Vector averaged cross-power spectrum Baseline: EF (01) - T6 (06)
Timerange: 00/07:46:59 to 00/07:50:28

Plot file version 85 created 03-OCT-2017 13:27:31

J1108+4330 EG096C.UVDATA.1

Freq = 4.7990 GHz, Bw = 32.000 MH No calibration applied and no bandpass applied

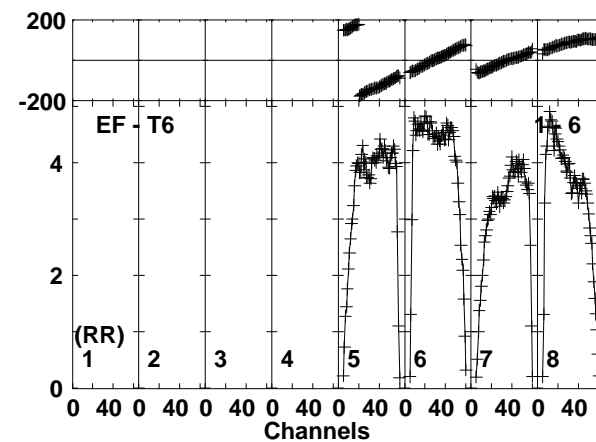
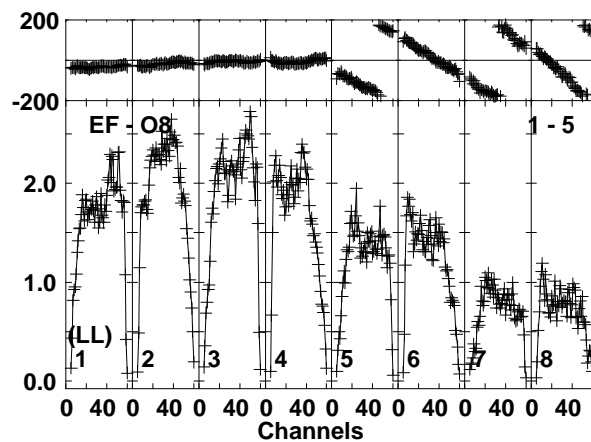
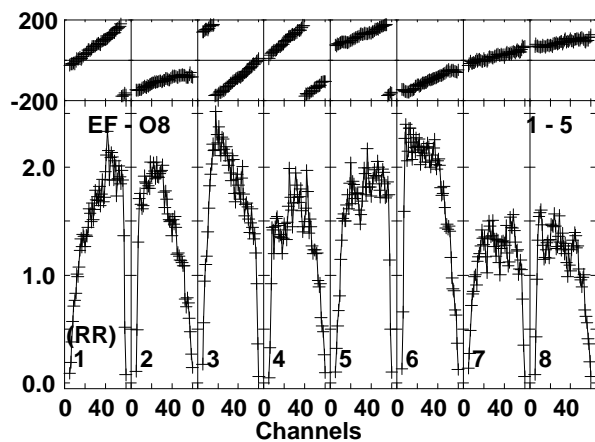
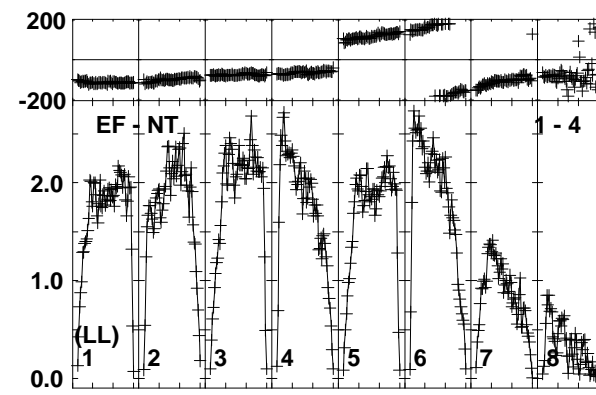
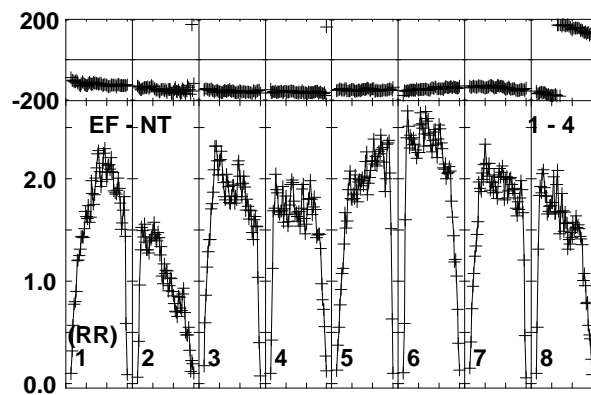
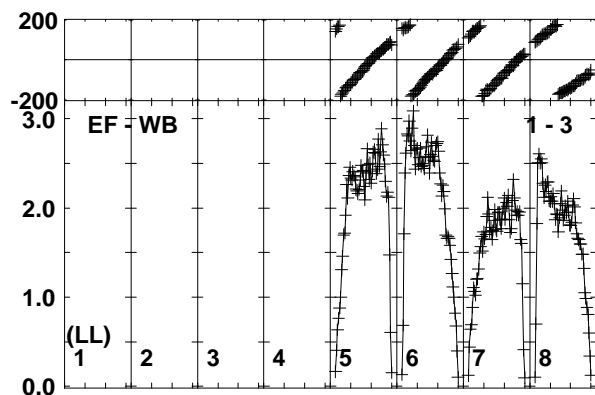
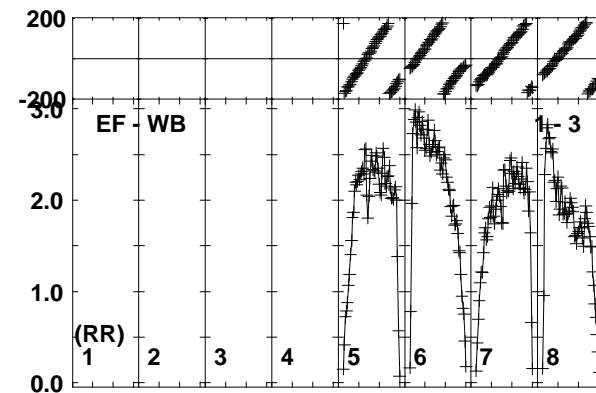
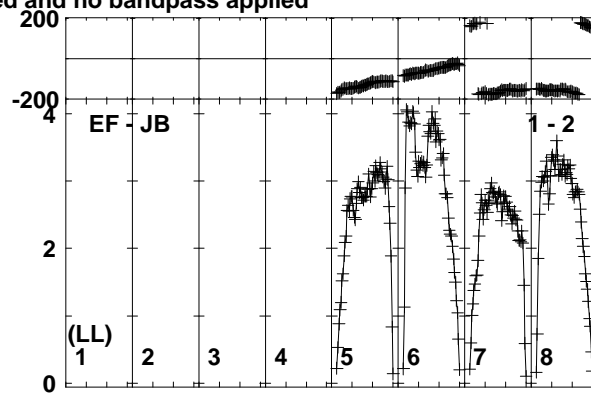
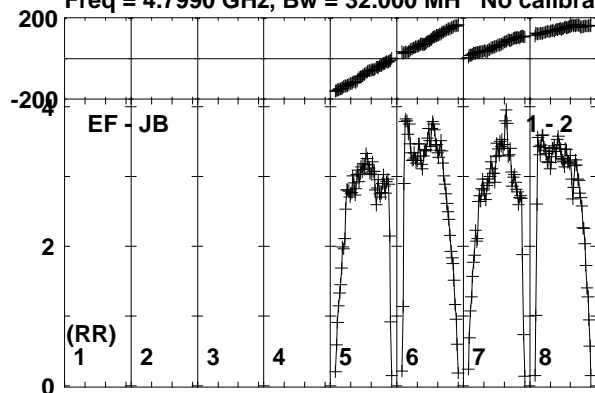

Lower frame: Milli Ampl Jy Top frame: Phas deg
Vector averaged cross-power spectrum Baseline: EF (01) - JB (02)
Timerange: 00/07:51:10 to 00/07:52:08

Plot file version 86 created 03-OCT-2017 13:27:31

J1108+4330 EG096C.UVDATA.1

Freq = 4.7990 GHz, Bw = 32.000 MH No calibration applied and no bandpass applied

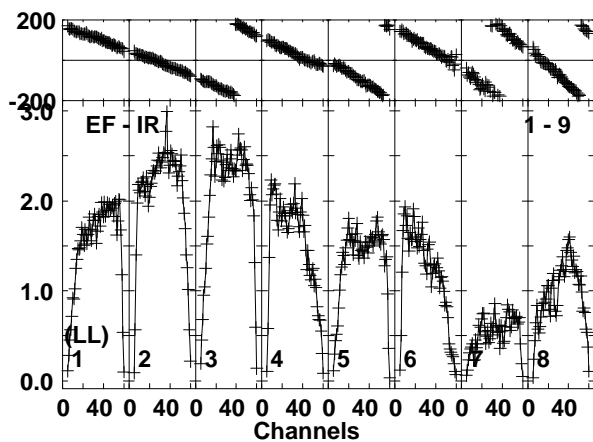
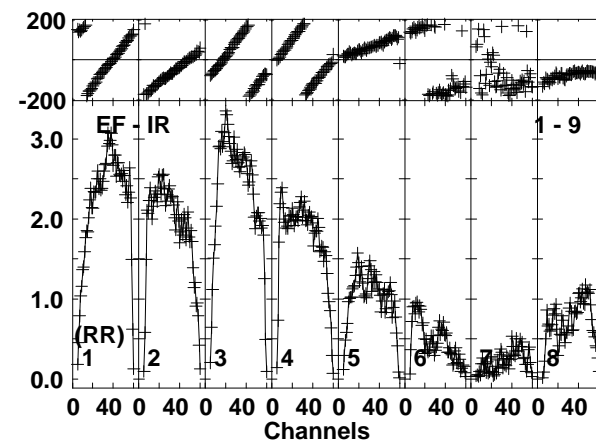
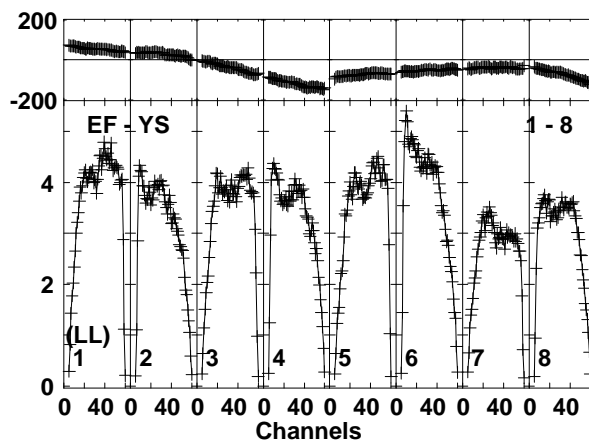
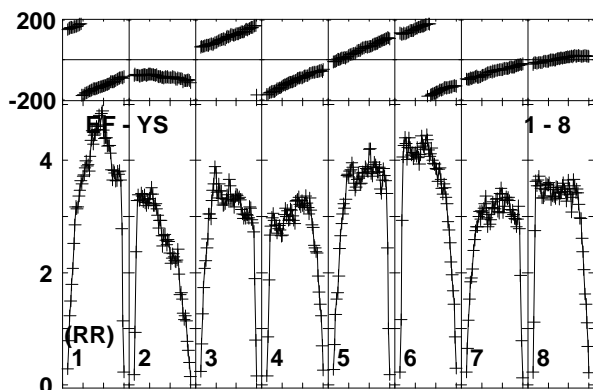
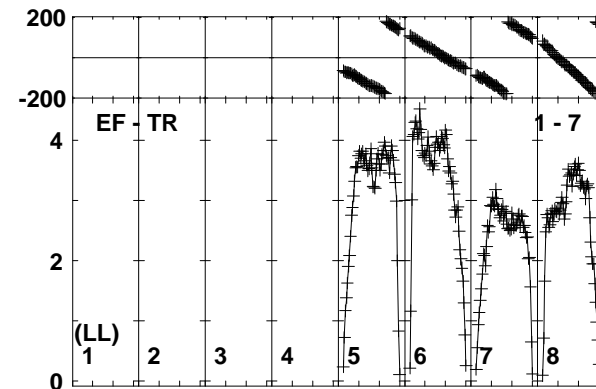
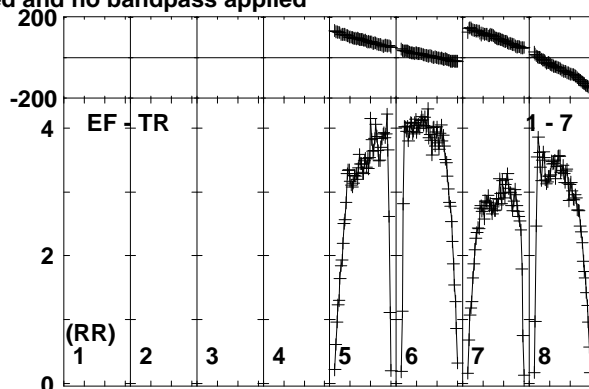
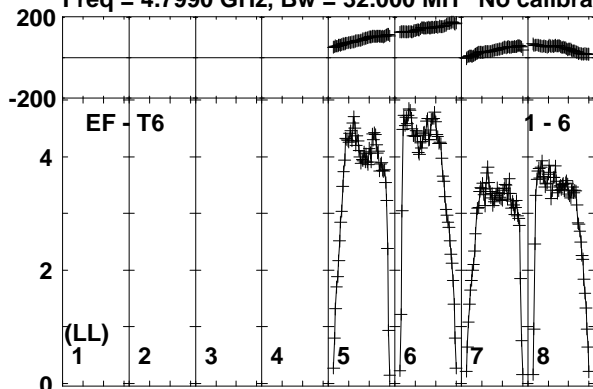

Lower frame: Milli Ampl Jy Top frame: Phas deg
Vector averaged cross-power spectrum Baseline: EF (01) - T6 (06)
Timerange: 00/07:51:10 to 00/07:52:08

Plot file version 87 created 03-OCT-2017 13:27:31

ARUMA EG096C.UVDATA.1

Freq = 4.7990 GHz, Bw = 32.000 MH No calibration applied and no bandpass applied

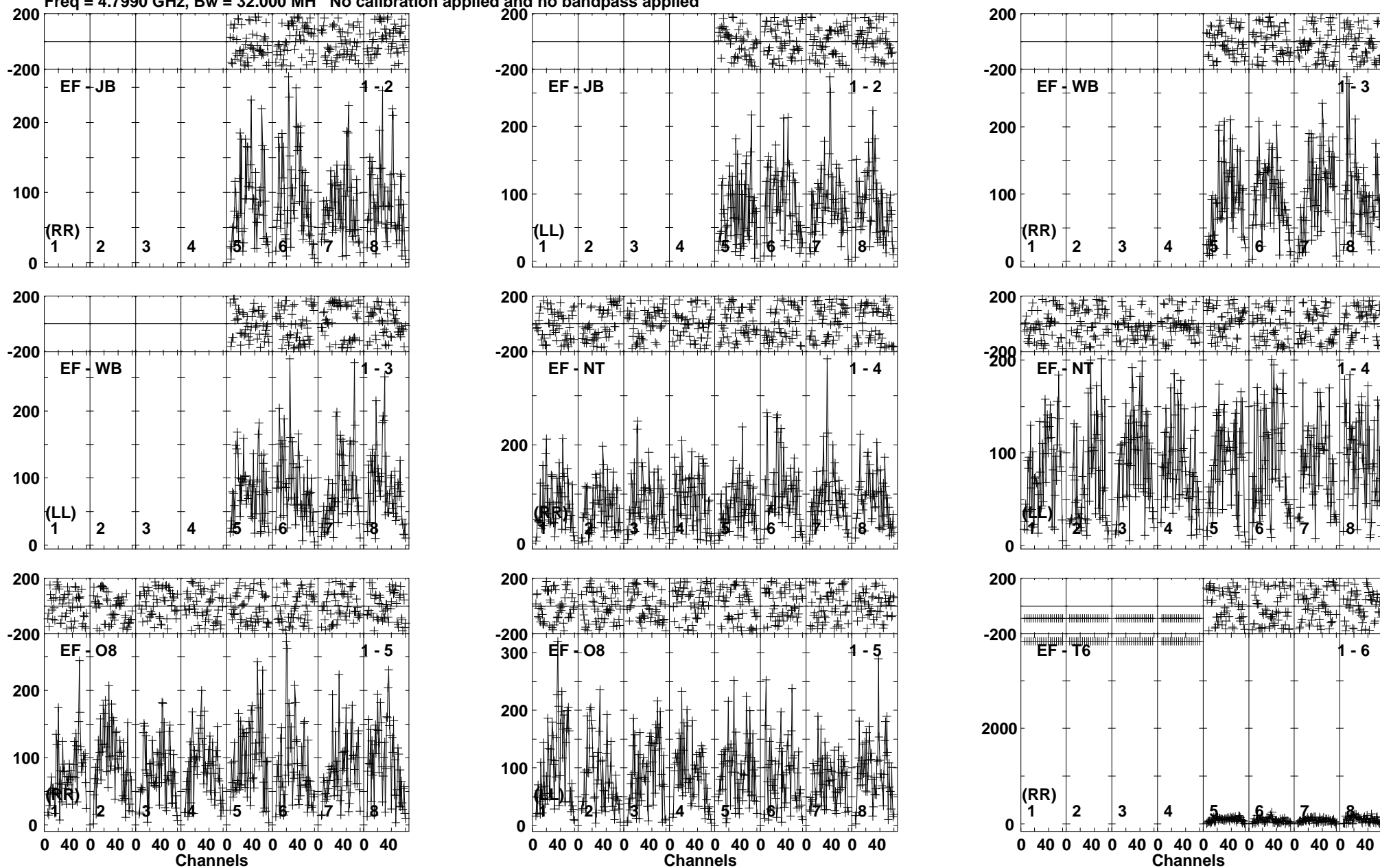

Lower frame: Micro Ampl Jy Top frame: Phas deg
Vector averaged cross-power spectrum Baseline: EF (01) - JB (02)
Timerange: 00/07:52:09 to 00/07:55:38

Plot file version 88 created 03-OCT-2017 13:27:32

ARUMA EG096C.UVDATA.1

Freq = 4.7990 GHz, Bw = 32.000 MH No calibration applied and no bandpass applied

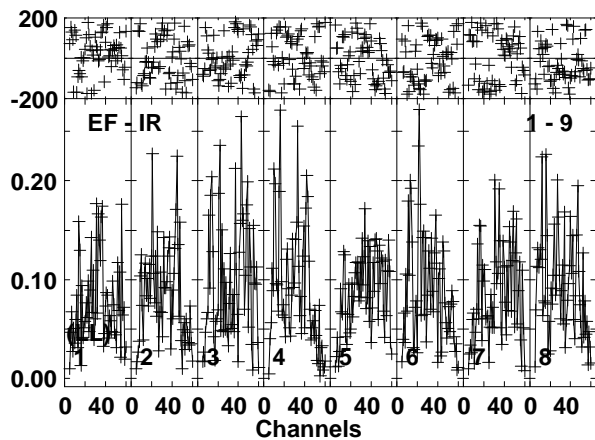
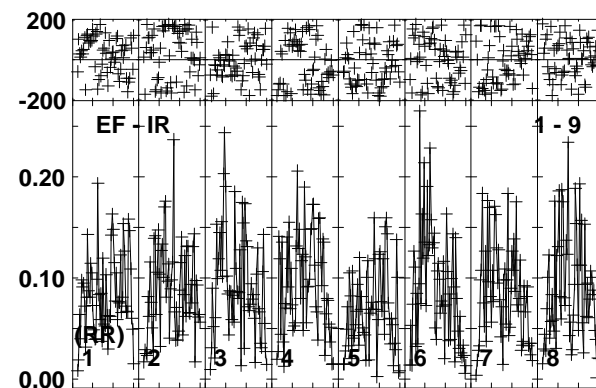
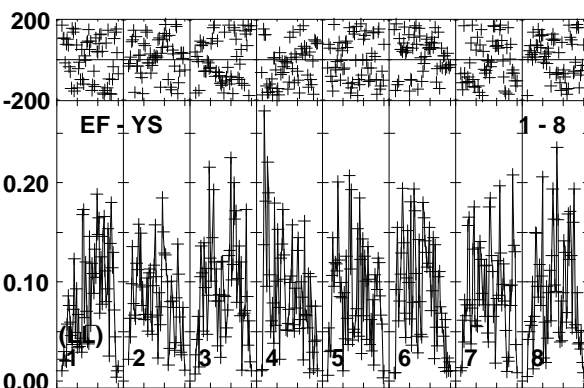
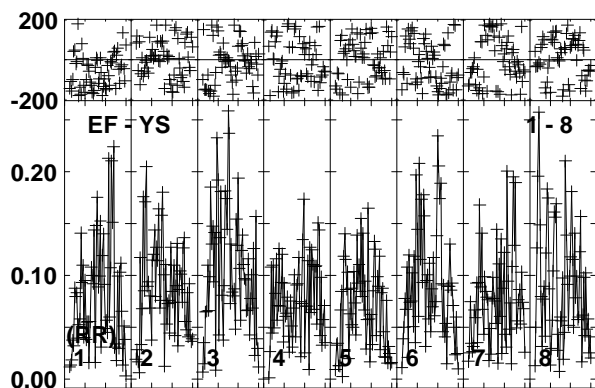
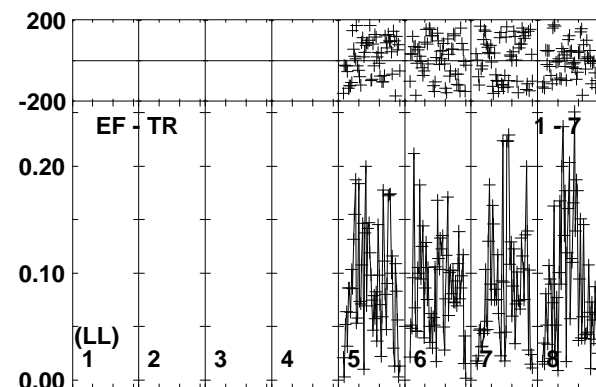
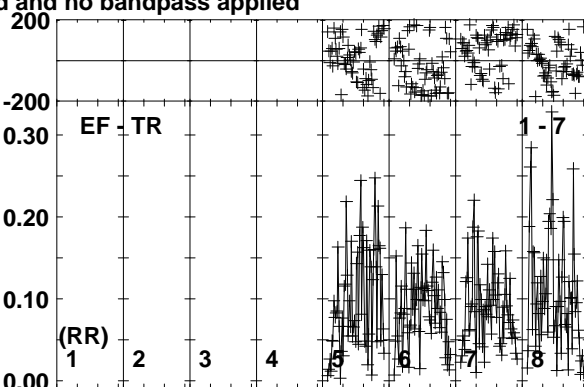
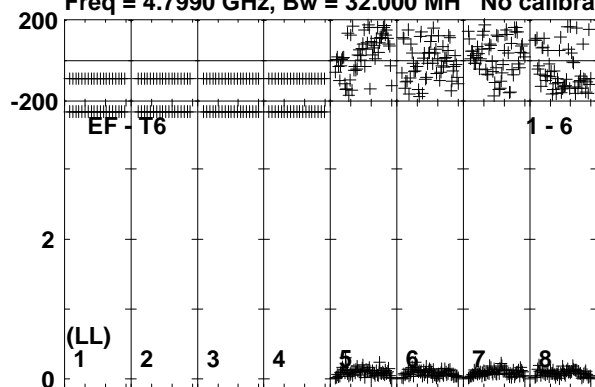

Lower frame: Milli Ampl Jy Top frame: Phas deg
Vector averaged cross-power spectrum Baseline: EF (01) - T6 (06)
Timerange: 00/07:52:09 to 00/07:55:38

Plot file version 89 created 03-OCT-2017 13:27:32

J1108+4330 EG096C.UVDATA.1

Freq = 4.7990 GHz, Bw = 32.000 MH No calibration applied and no bandpass applied

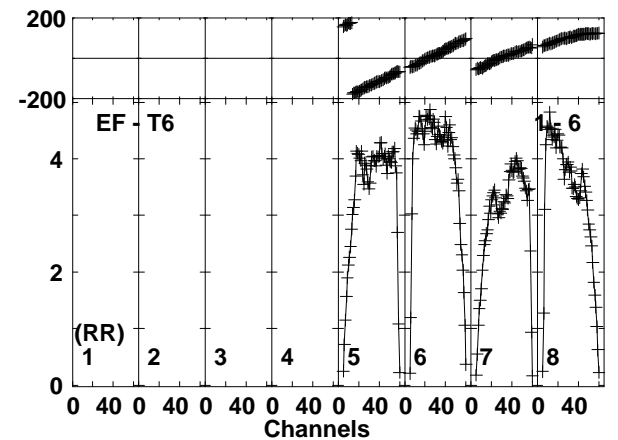
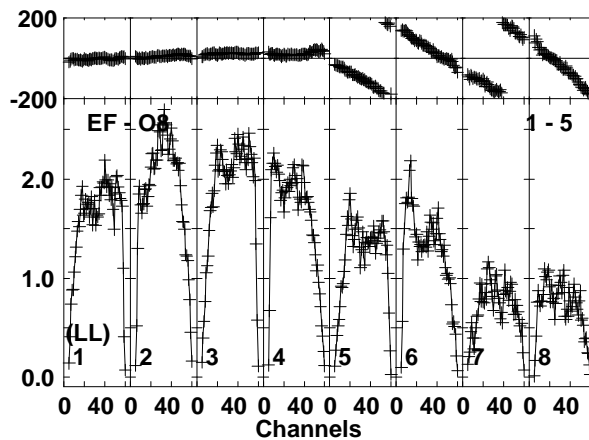
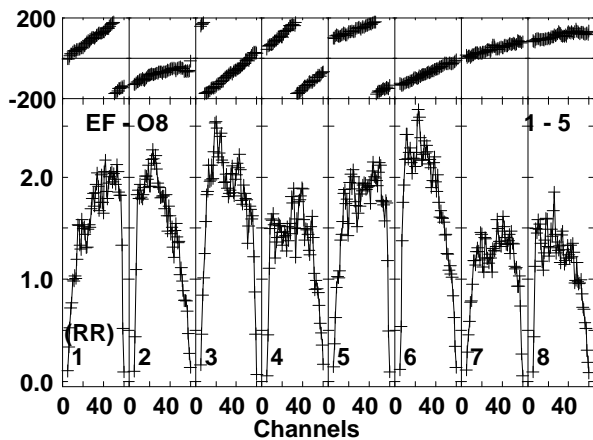
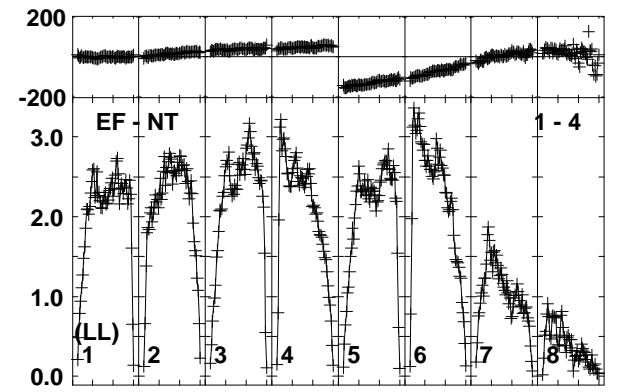
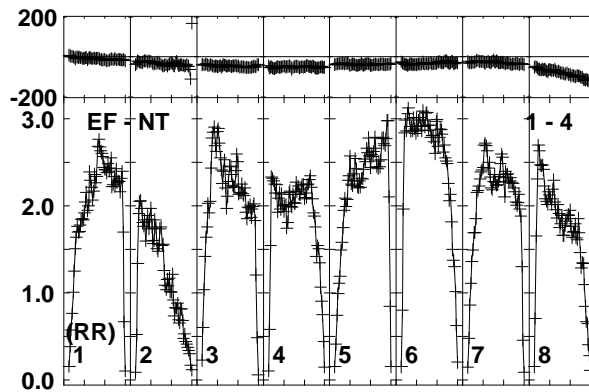
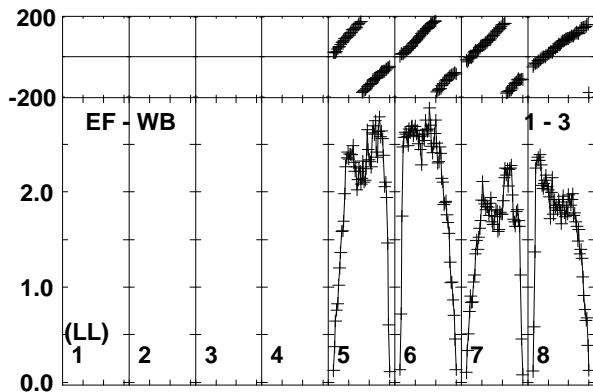
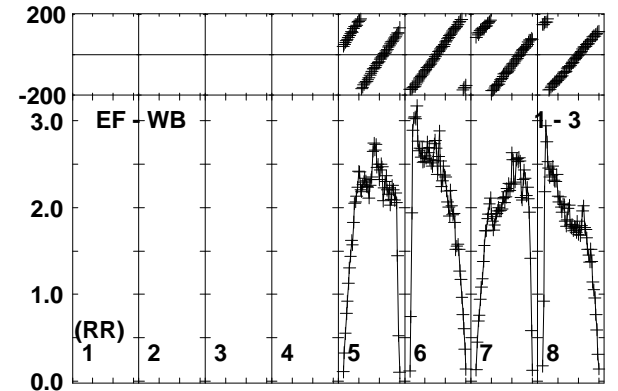
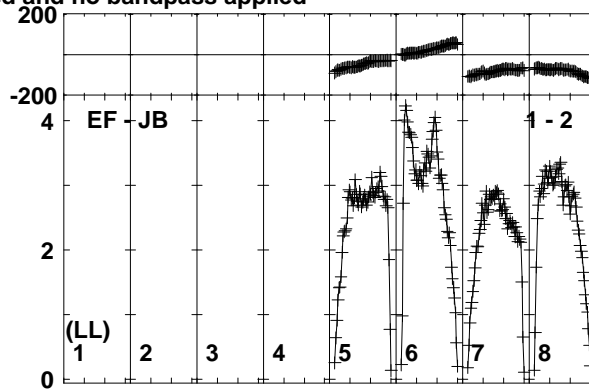
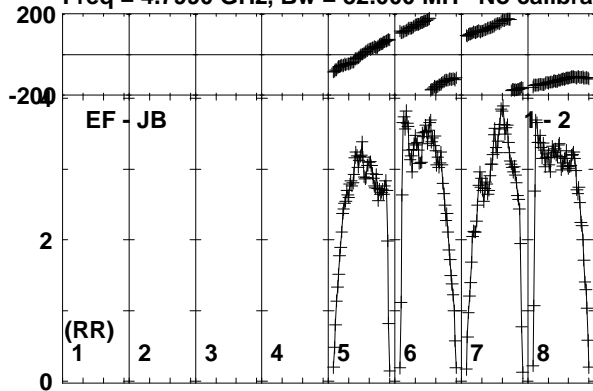

Lower frame: Milli Ampl Jy Top frame: Phas deg
Vector averaged cross-power spectrum Baseline: EF (01) - JB (02)
Timerange: 00/07:55:39 to 00/07:57:08

Plot file version 90 created 03-OCT-2017 13:27:32

J1108+4330 EG096C.UVDATA.1

Freq = 4.7990 GHz, Bw = 32.000 MH No calibration applied and no bandpass applied

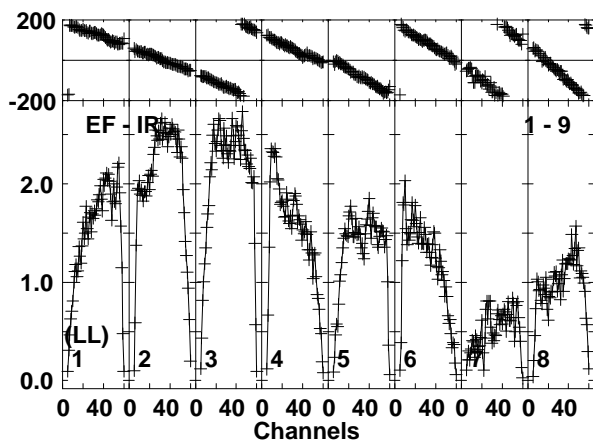
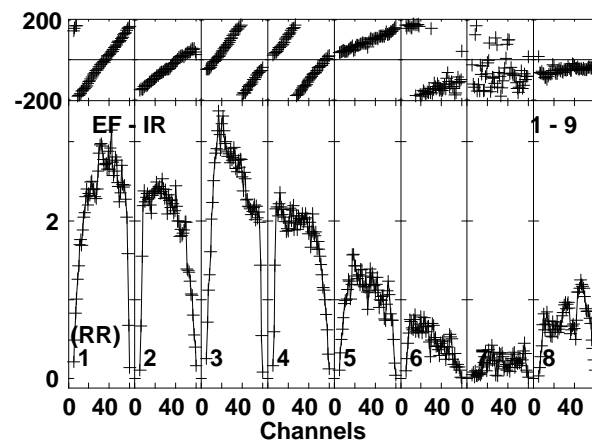
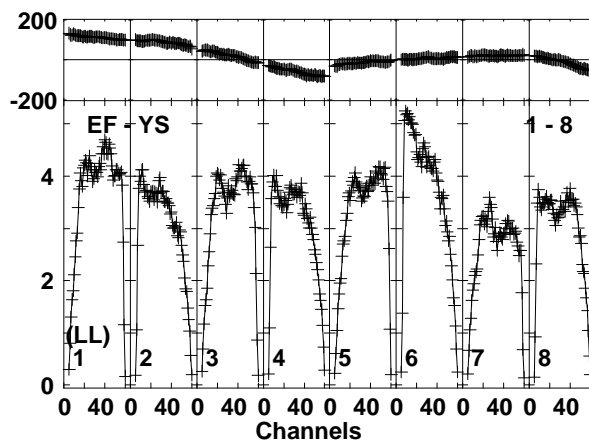
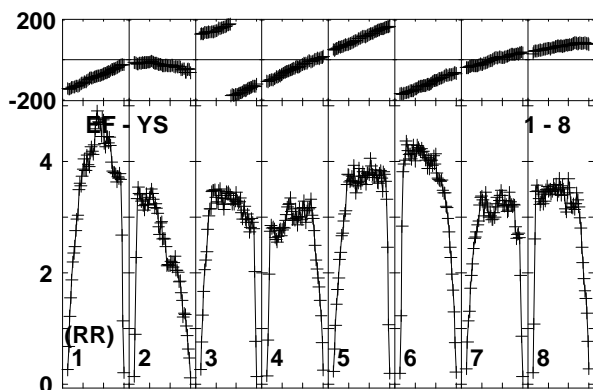
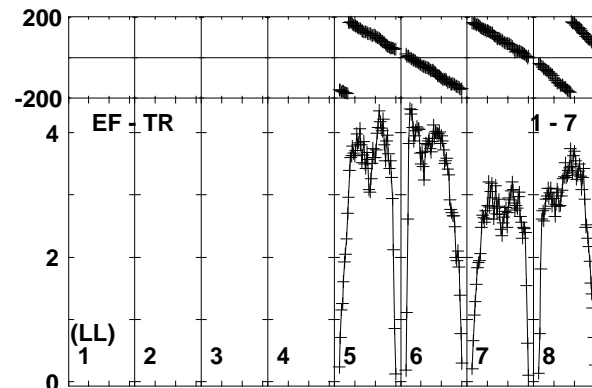
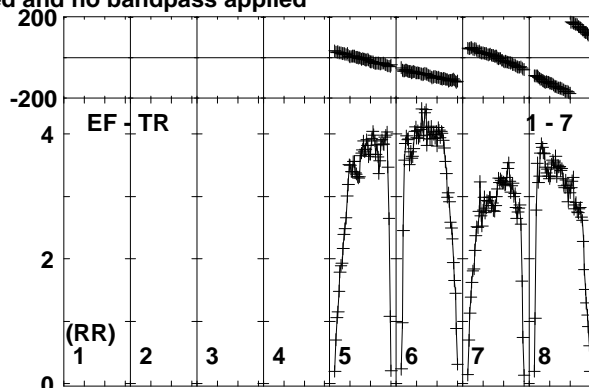
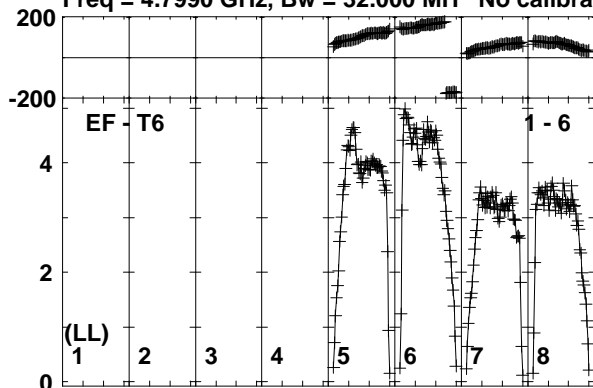

Lower frame: Milli Ampl Jy Top frame: Phas deg
Vector averaged cross-power spectrum Baseline: EF (01) - T6 (06)
Timerange: 00/07:55:39 to 00/07:57:08

Plot file version 92 created 03-OCT-2017 13:27:32

ARUMA EG096C.UVDATA.1

Freq = 4.7990 GHz, Bw = 32.000 MH No calibration applied and no bandpass applied

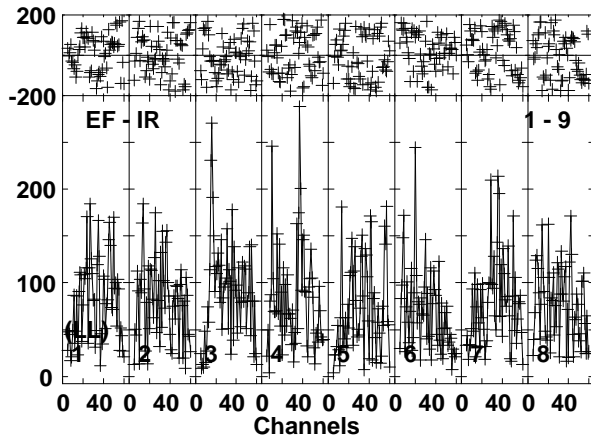
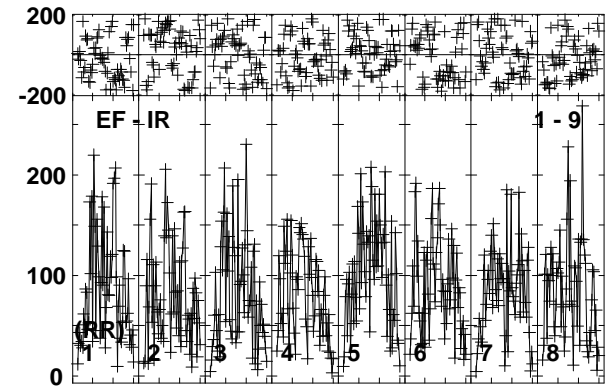
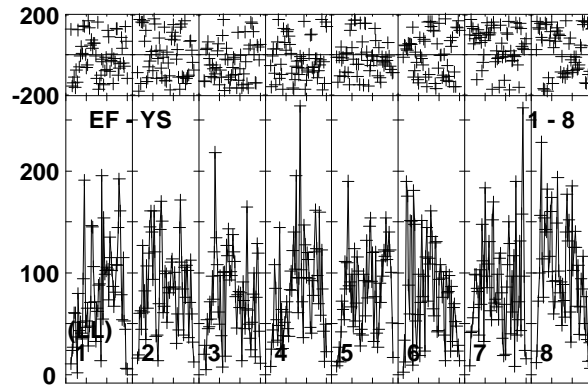
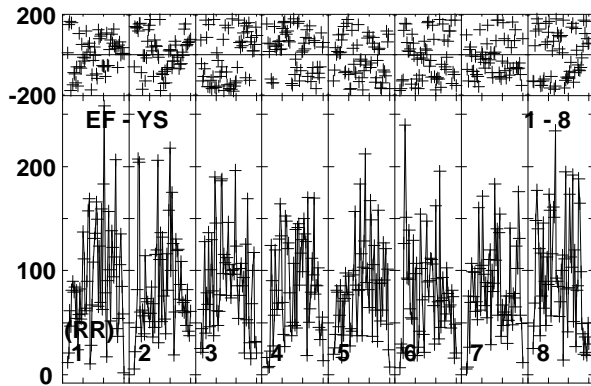
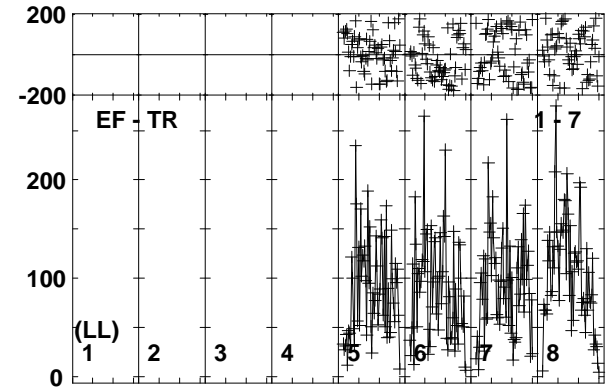
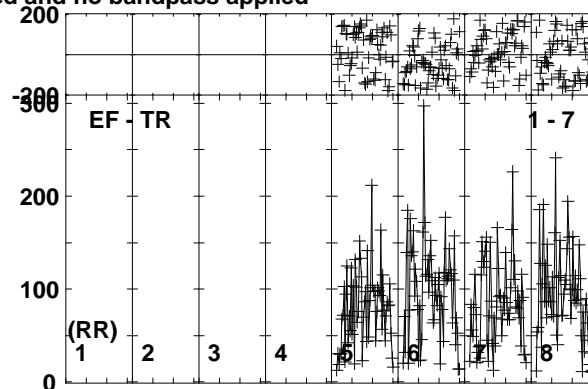
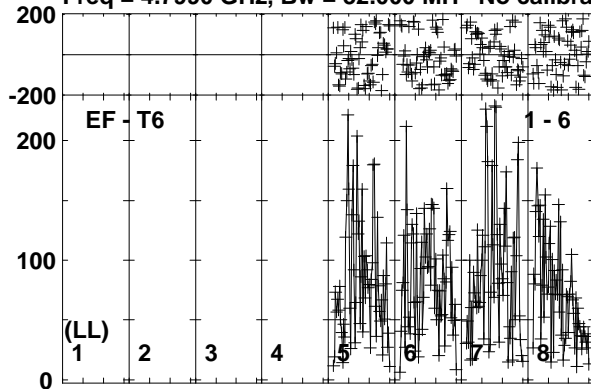

Lower frame: Micro Ampl Jy Top frame: Phas deg
Vector averaged cross-power spectrum Baseline: EF (01) - T6 (06)
Timerange: 00/07:57:09 to 00/08:00:39

Plot file version 93 created 03-OCT-2017 13:27:33

J1108+4330 EG096C.UVDATA.1

Freq = 4.7990 GHz, Bw = 32.000 MH No calibration applied and no bandpass applied

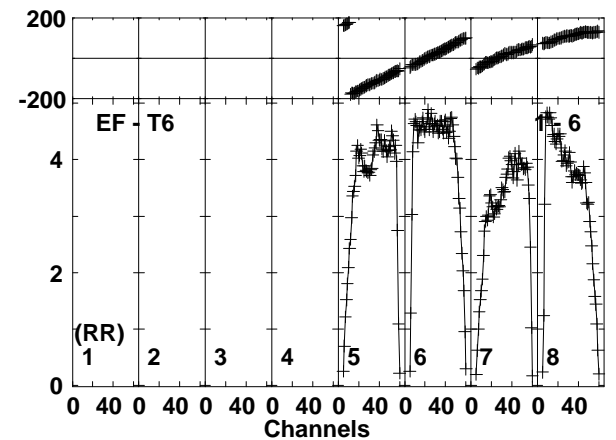
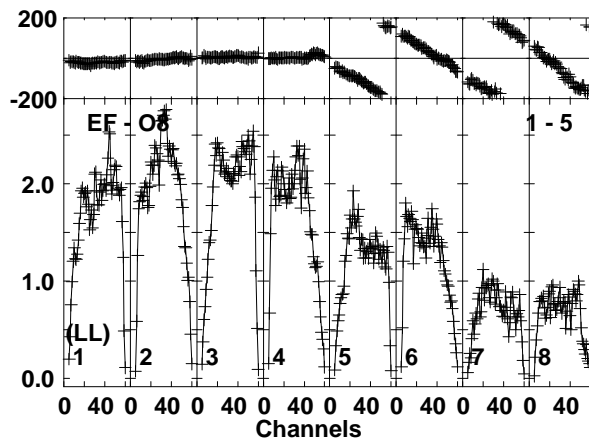
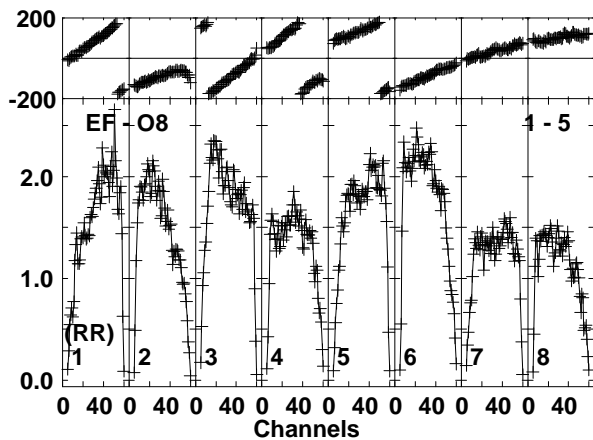
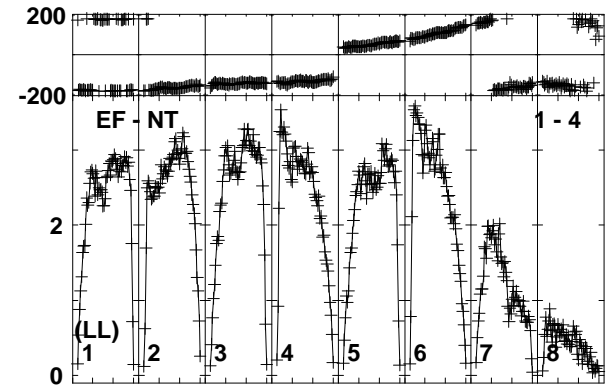
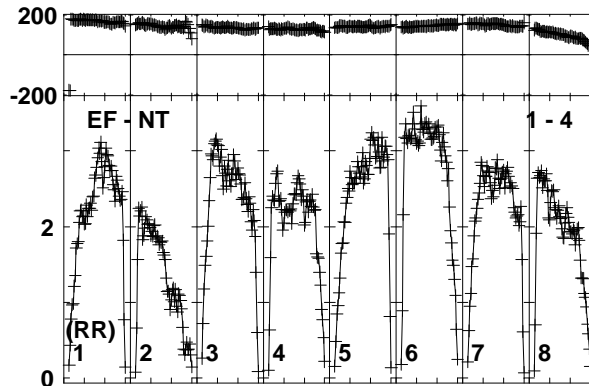
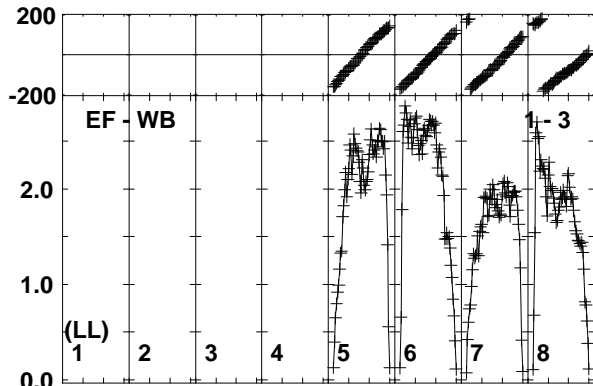
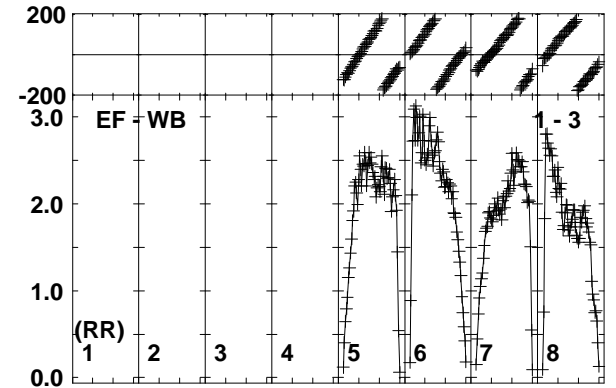
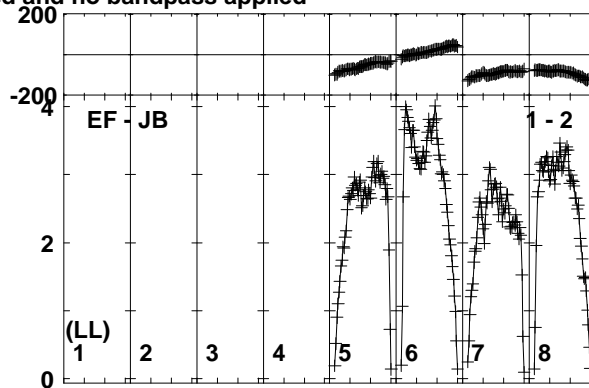
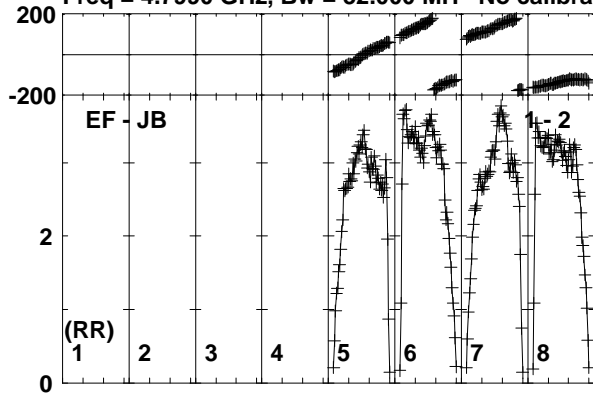

Lower frame: Milli Ampl Jy Top frame: Phas deg
Vector averaged cross-power spectrum Baseline: EF (01) - JB (02)
Timerange: 00/08:01:19 to 00/08:02:18

Plot file version 94 created 03-OCT-2017 13:27:33

J1108+4330 EG096C.UVDATA.1

Freq = 4.7990 GHz, Bw = 32.000 MH No calibration applied and no bandpass applied

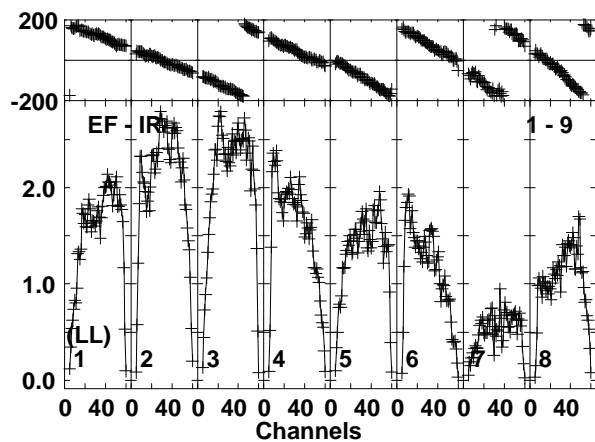
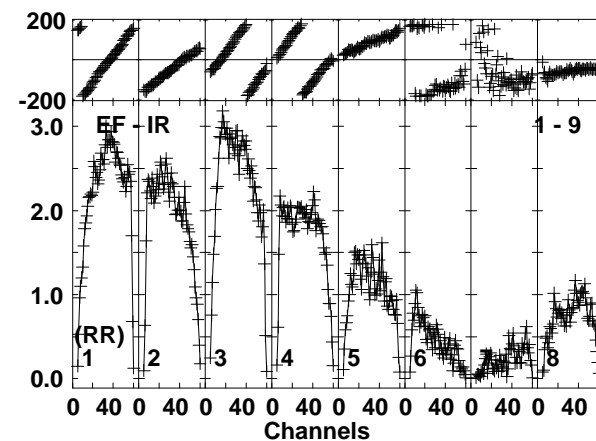
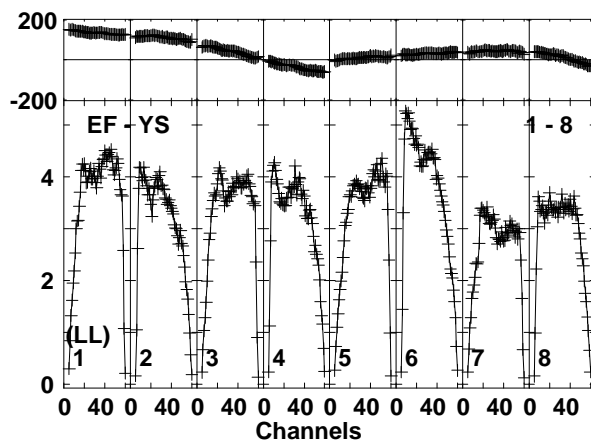
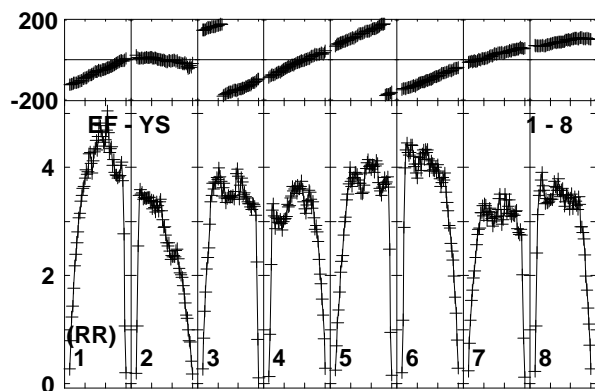
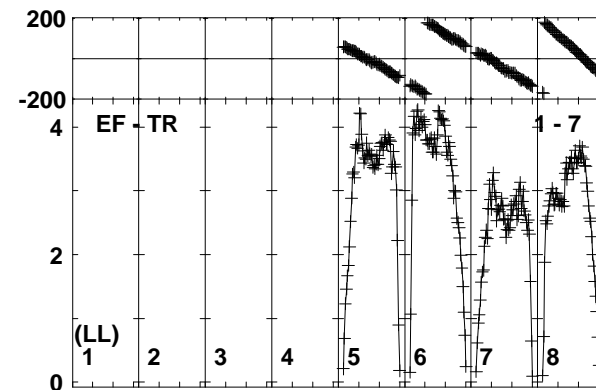
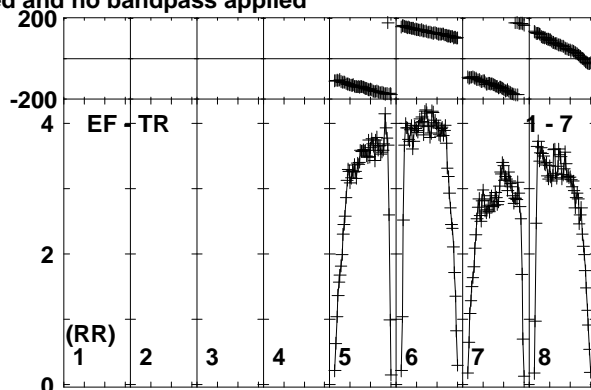
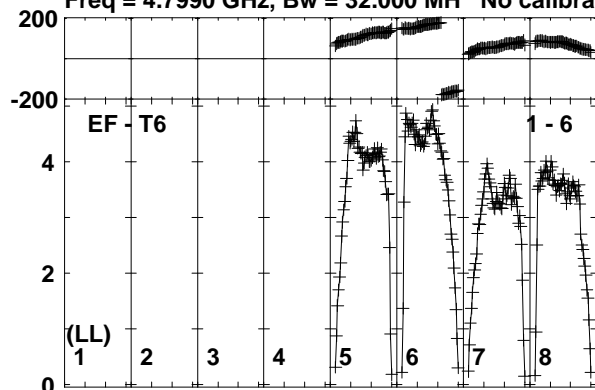

Lower frame: Milli Ampl Jy Top frame: Phas deg
Vector averaged cross-power spectrum Baseline: EF (01) - T6 (06)
Timerange: 00/08:01:19 to 00/08:02:18

Plot file version 95 created 03-OCT-2017 13:27:33

ARUMA EG096C.UVDATA.1

Freq = 4.7990 GHz, Bw = 32.000 MH No calibration applied and no bandpass applied

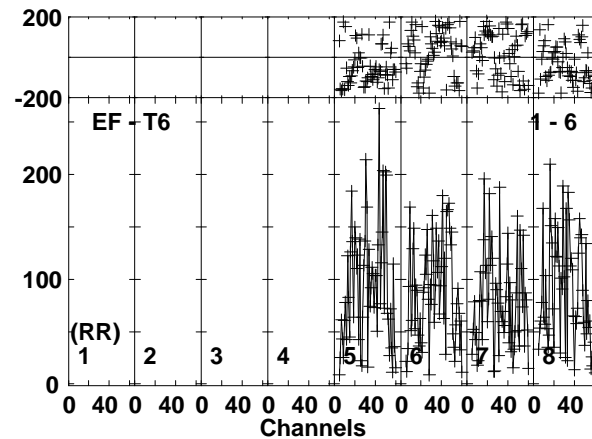
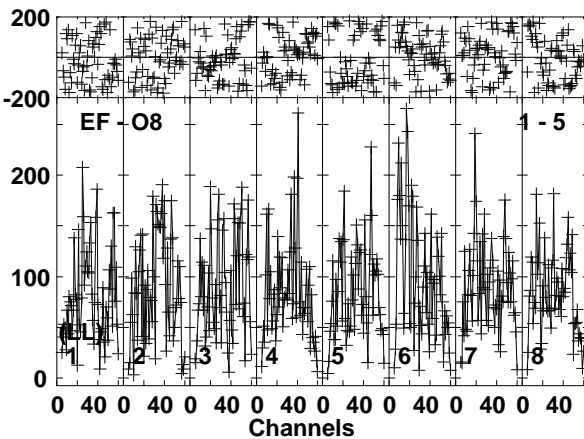
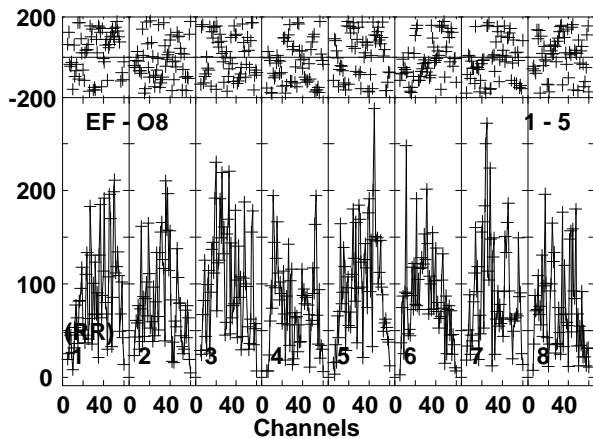
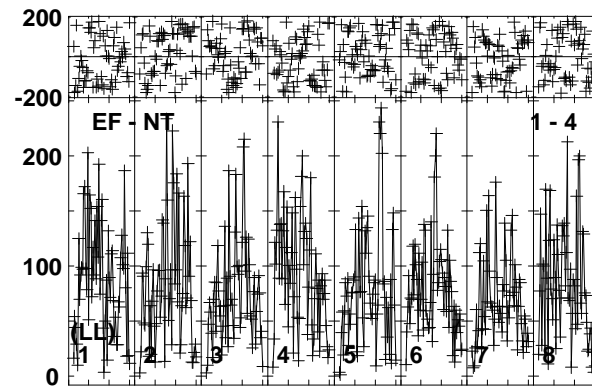
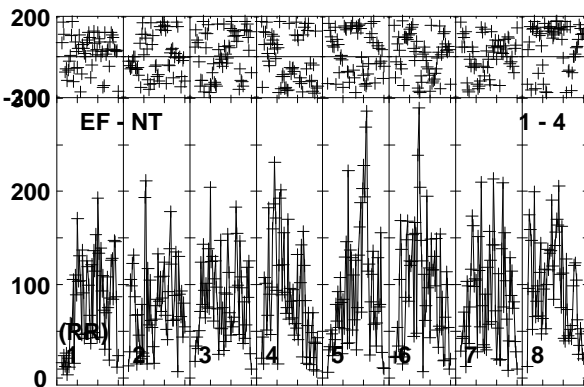
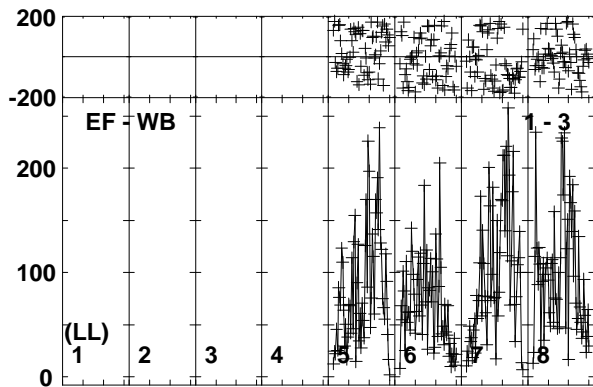
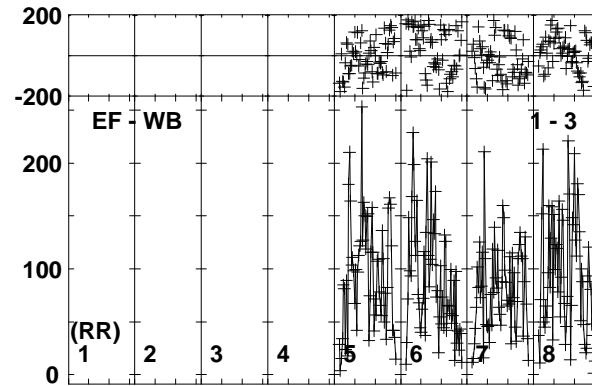
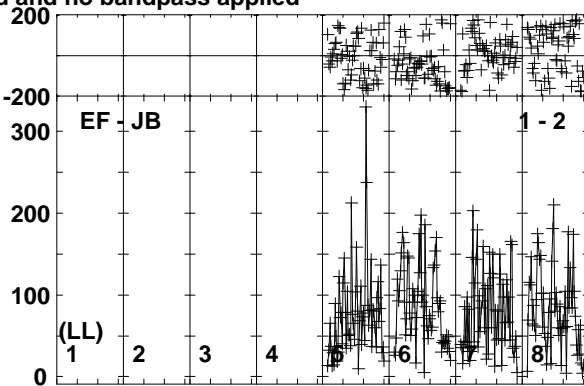
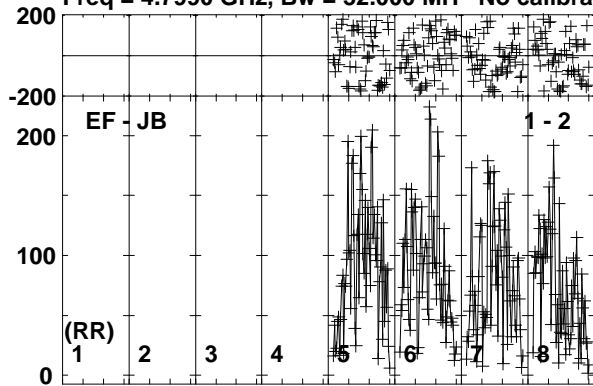

Lower frame: Micro Ampl Jy Top frame: Phas deg
Vector averaged cross-power spectrum Baseline: EF (01) - JB (02)
Timerange: 00/08:02:19 to 00/08:05:49

Plot file version 96 created 03-OCT-2017 13:27:33

ARUMA EG096C.UVDATA.1

Freq = 4.7990 GHz, Bw = 32.000 MH No calibration applied and no bandpass applied

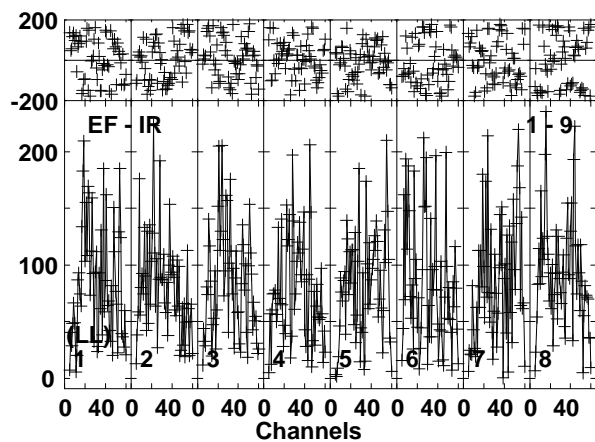
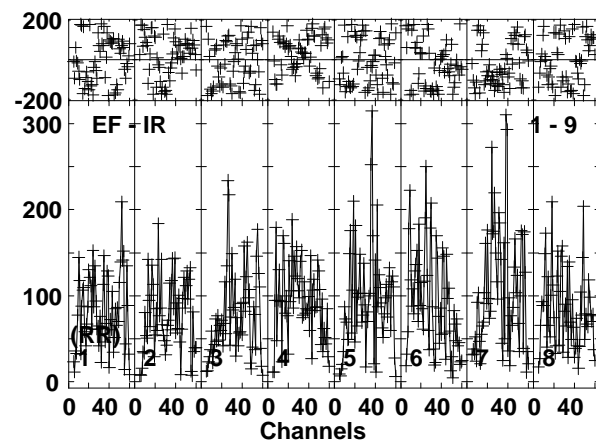
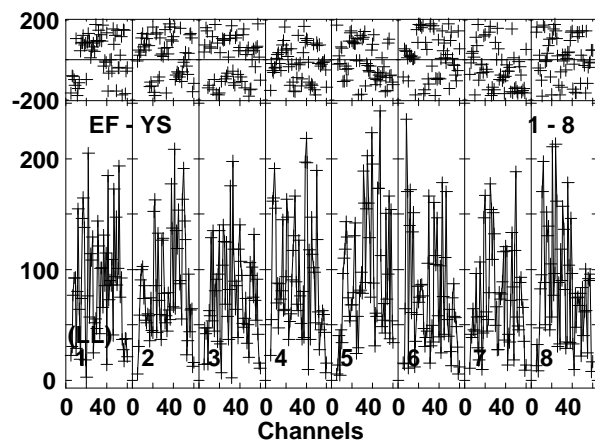
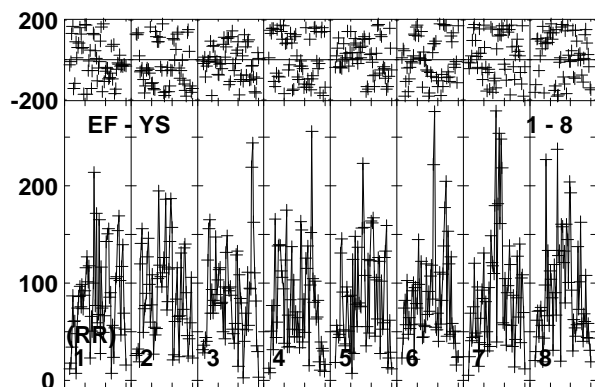
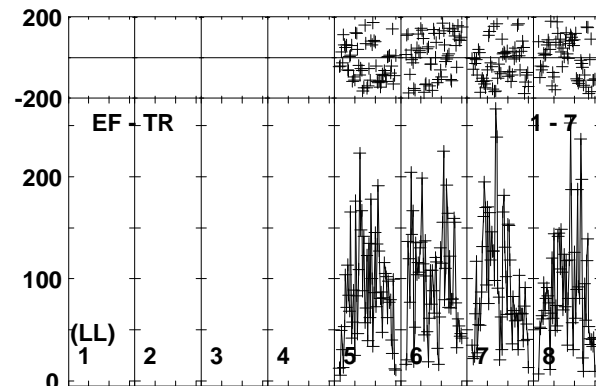
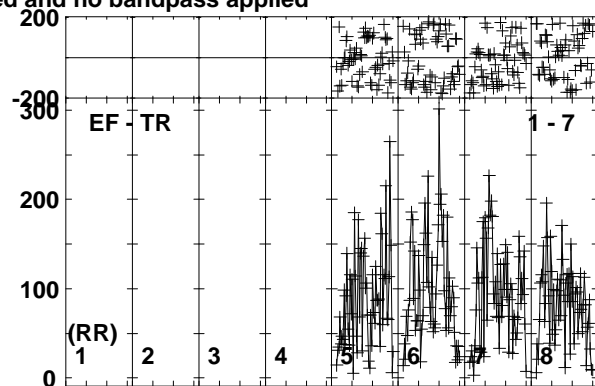
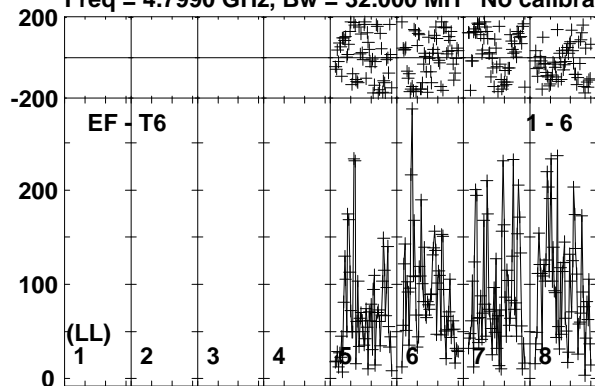

Lower frame: Micro Ampl Jy Top frame: Phas deg
Vector averaged cross-power spectrum Baseline: EF (01) - T6 (06)
Timerange: 00/08:02:19 to 00/08:05:49

Plot file version 97 created 03-OCT-2017 13:27:34

J1108+4330 EG096C.UVDATA.1

Freq = 4.7990 GHz, Bw = 32.000 MH No calibration applied and no bandpass applied

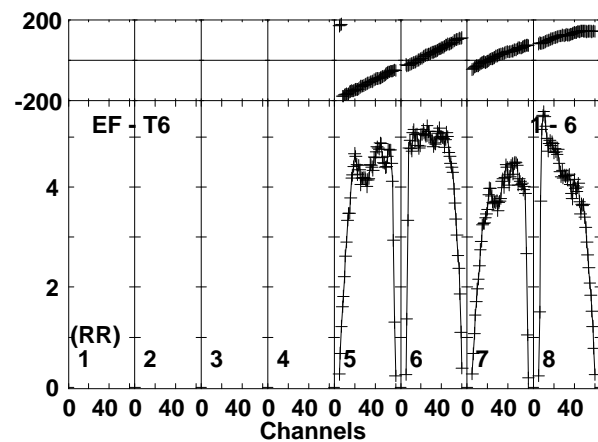
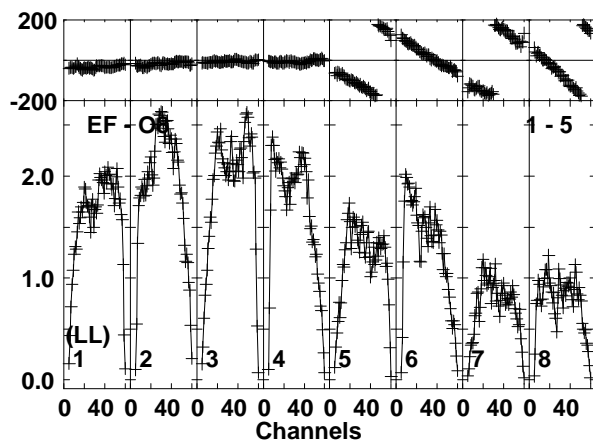
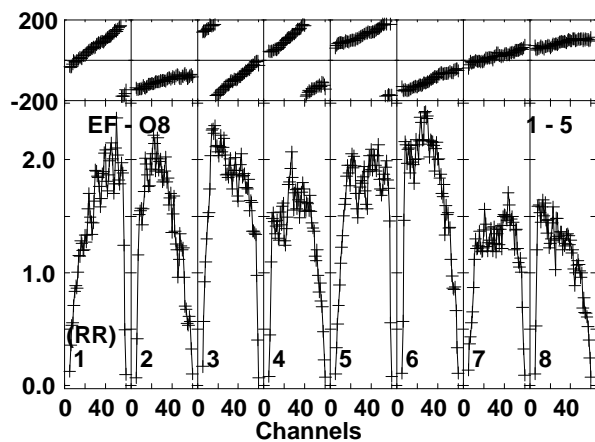
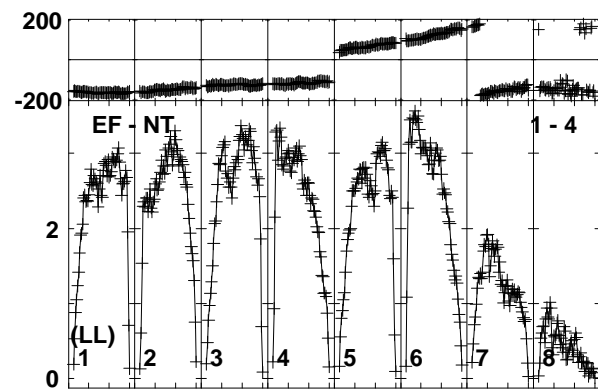
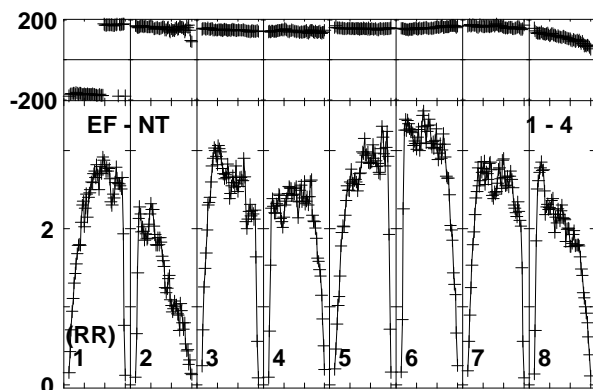
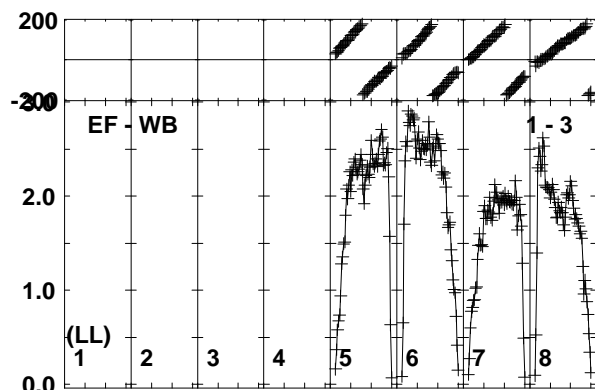
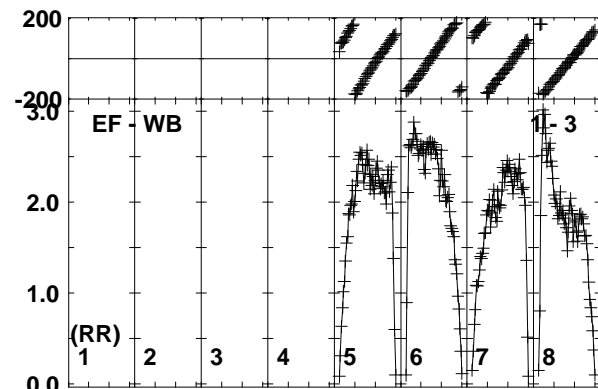
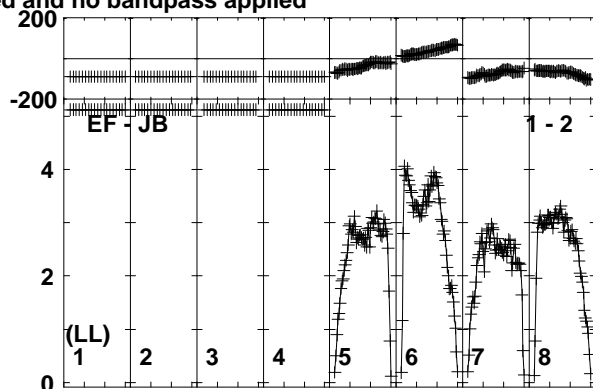
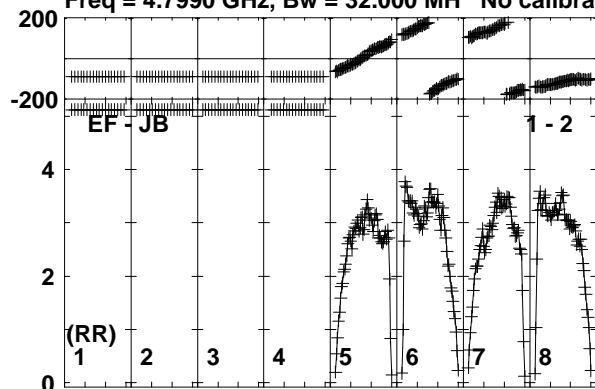

Lower frame: Milli Ampl Jy Top frame: Phas deg
Vector averaged cross-power spectrum Baseline: EF (01) - JB (02)
Timerange: 00/08:05:49 to 00/08:07:18

Plot file version 98 created 03-OCT-2017 13:27:34

J1108+4330 EG096C.UVDATA.1

Freq = 4.7990 GHz, Bw = 32.000 MH No calibration applied and no bandpass applied

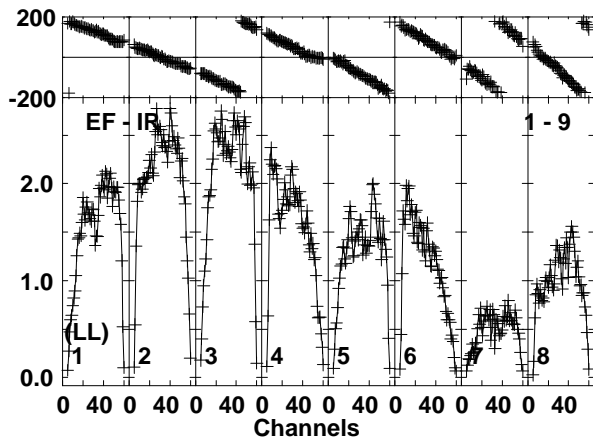
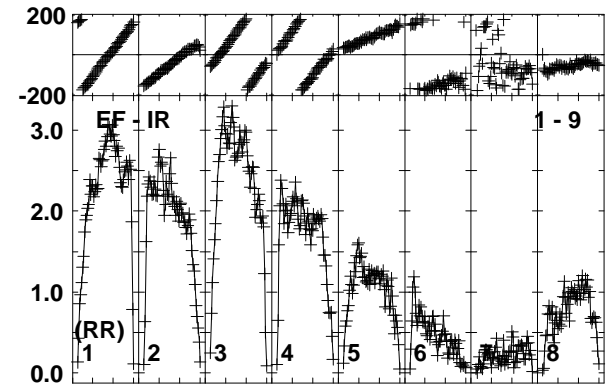
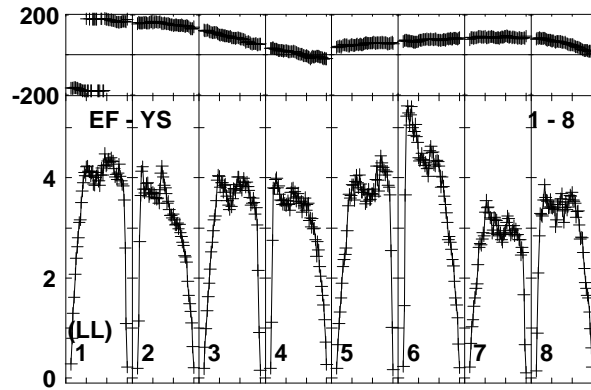
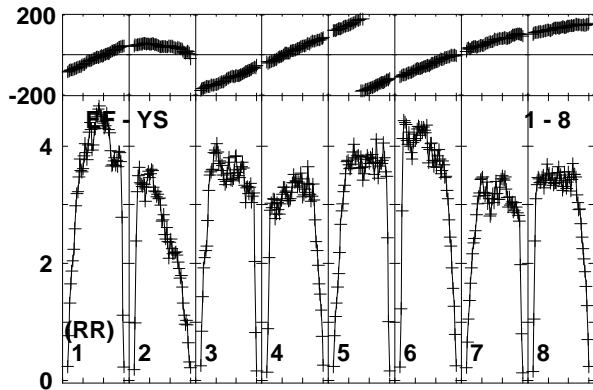
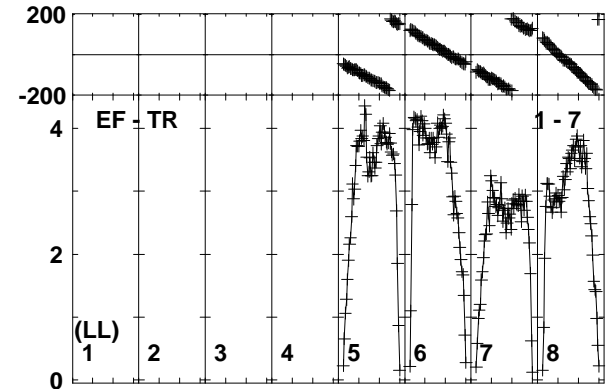
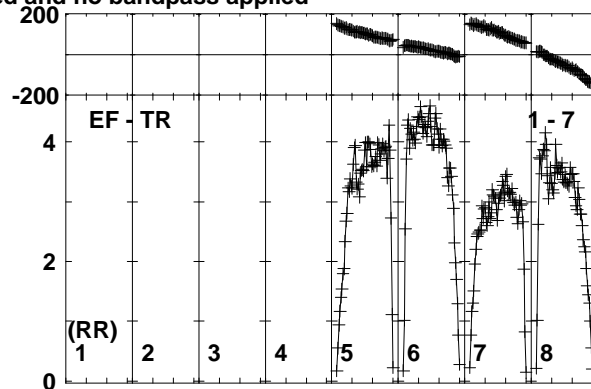
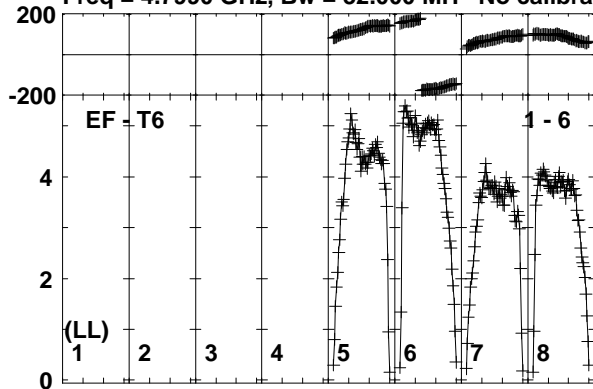

Lower frame: Milli Ampl Jy Top frame: Phas deg
Vector averaged cross-power spectrum Baseline: EF (01) - T6 (06)
Timerange: 00/08:05:49 to 00/08:07:18

Plot file version 99 created 03-OCT-2017 13:27:34

ARUMA EG096C.UVDATA.1

Freq = 4.7990 GHz, Bw = 32.000 MH No calibration applied and no bandpass applied

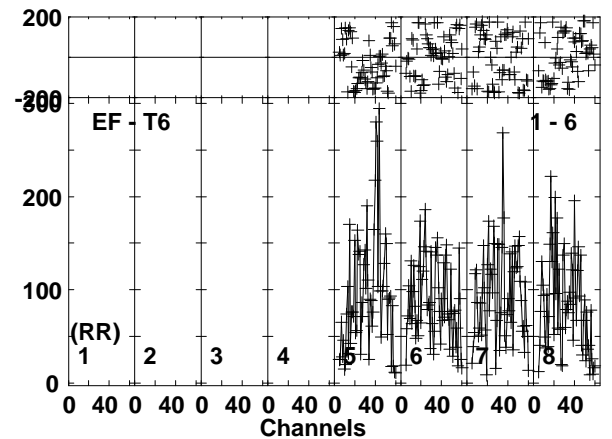
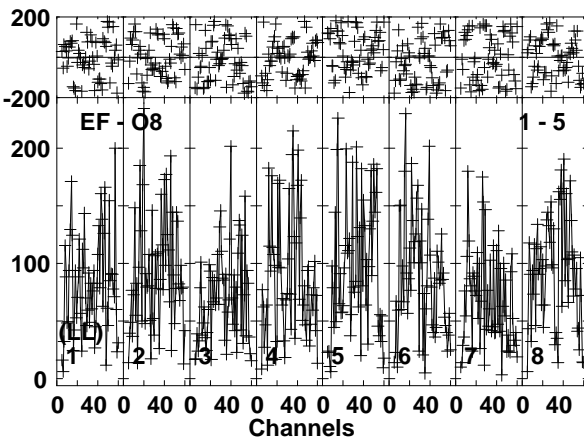
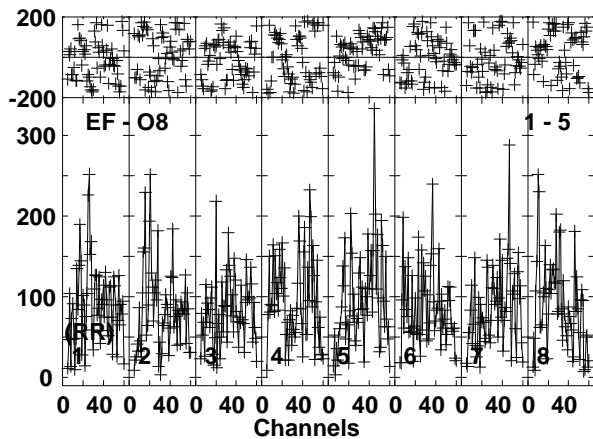
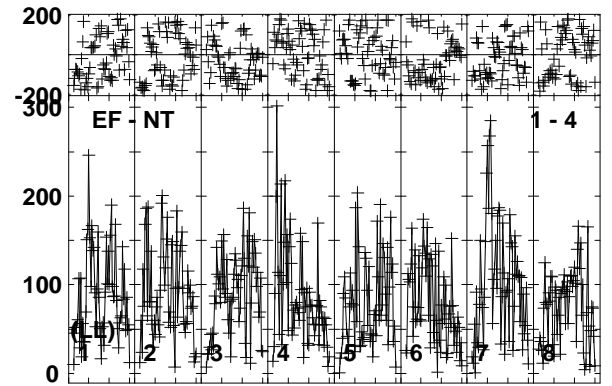
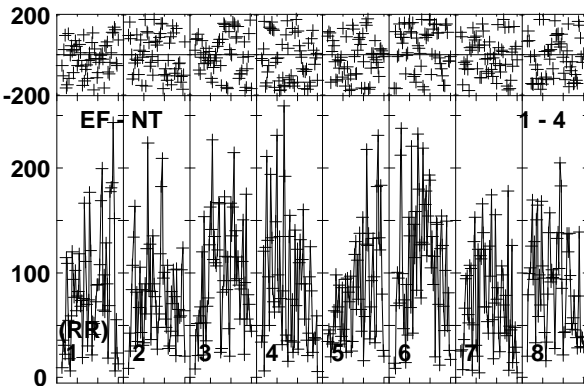
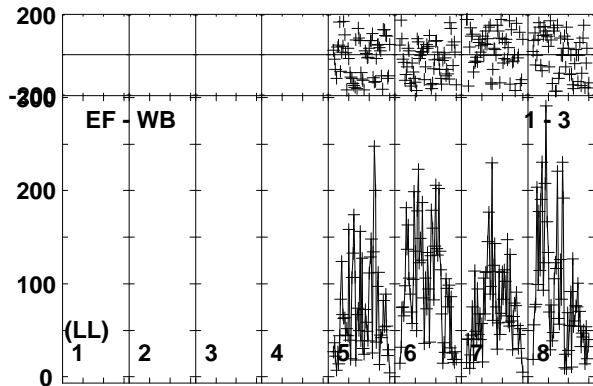
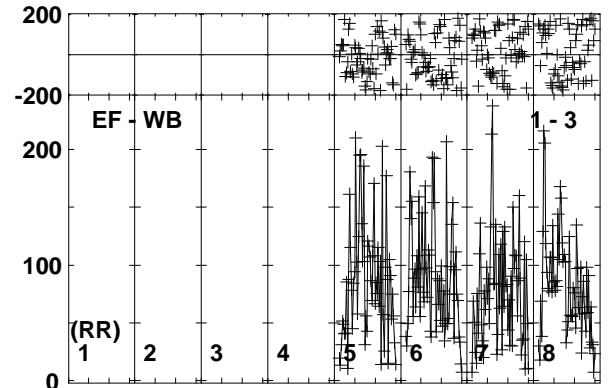
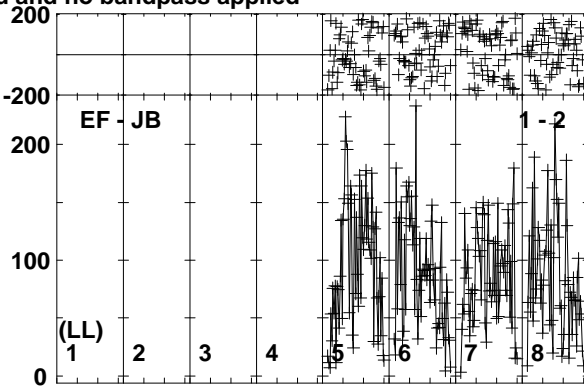
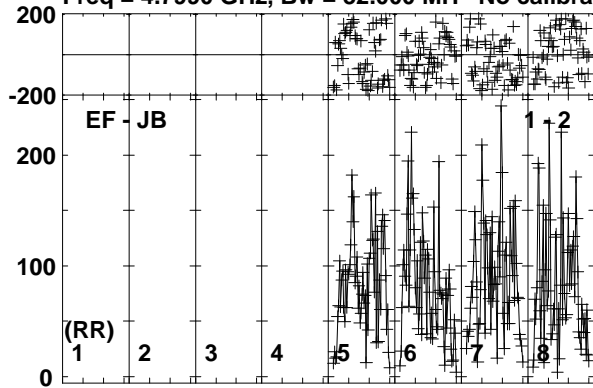

Lower frame: Micro Ampl Jy Top frame: Phas deg
Vector averaged cross-power spectrum Baseline: EF (01) - JB (02)
Timerange: 00/08:07:20 to 00/08:10:49

Plot file version 100 created 03-OCT-2017 13:27:34

ARUMA EG096C.UVDATA.1

Freq = 4.7990 GHz, Bw = 32.000 MH No calibration applied and no bandpass applied

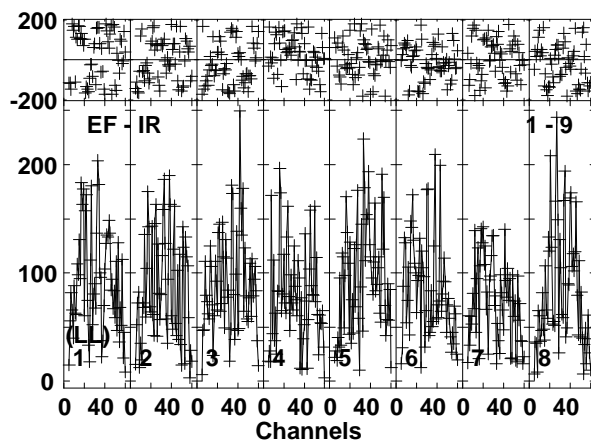
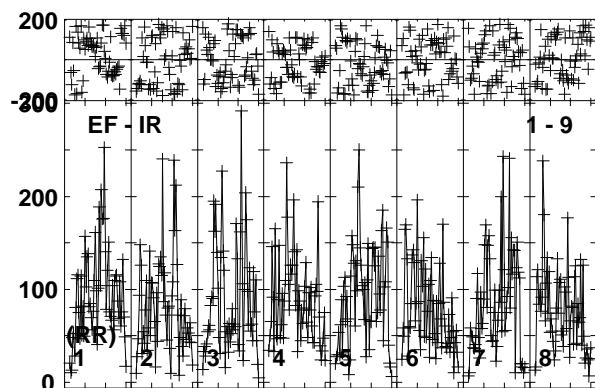
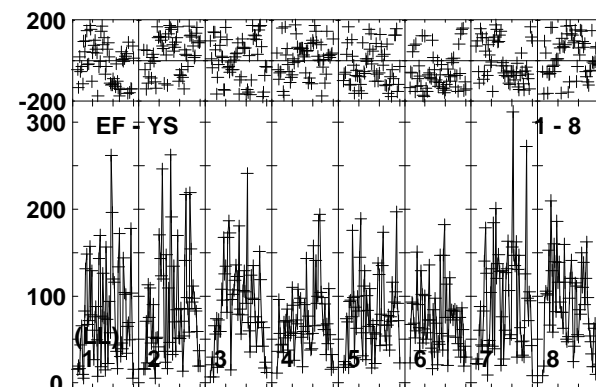
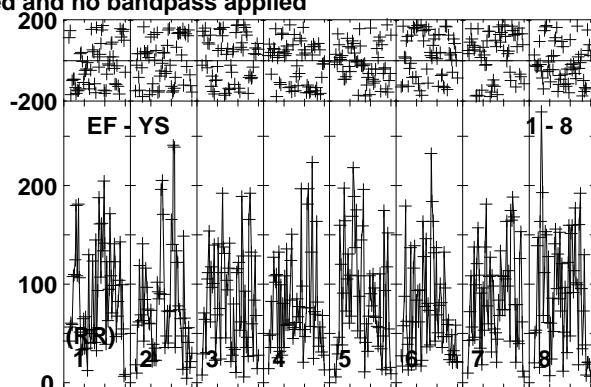
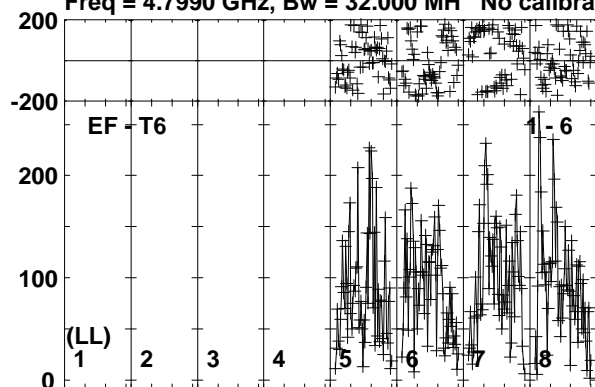

Lower frame: Micro Ampl Jy Top frame: Phas deg
Vector averaged cross-power spectrum Baseline: EF (01) - T6 (06)
Timerange: 00/08:07:20 to 00/08:10:49

Plot file version 101 created 03-OCT-2017 13:27:35

J1108+4330 EG096C.UVDATA.1

Freq = 4.7990 GHz, Bw = 32.000 MH No calibration applied and no bandpass applied

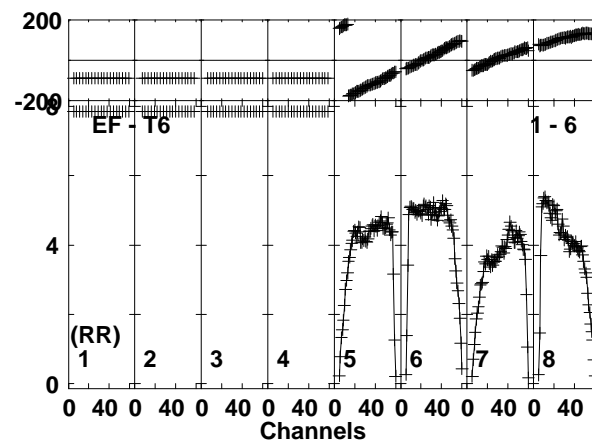
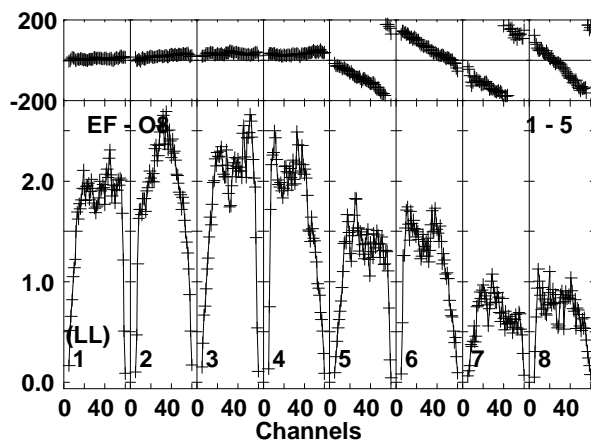
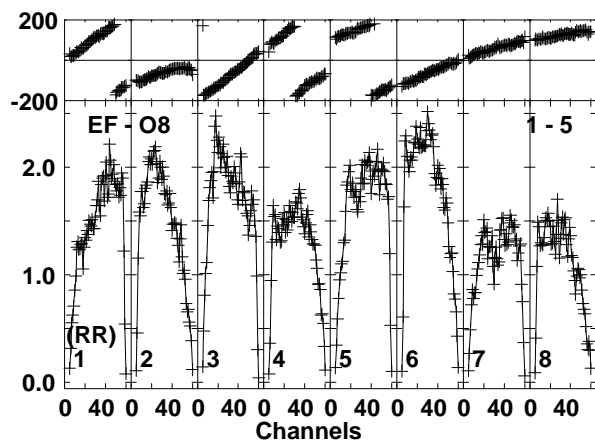
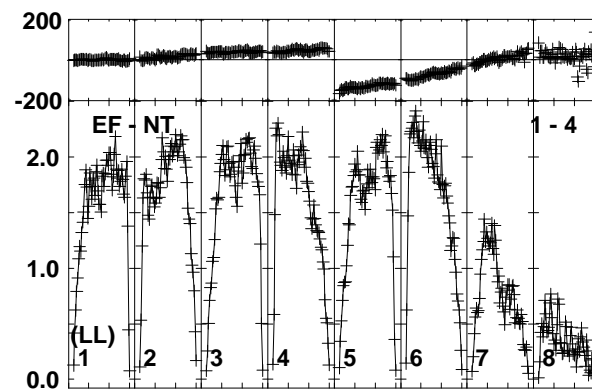
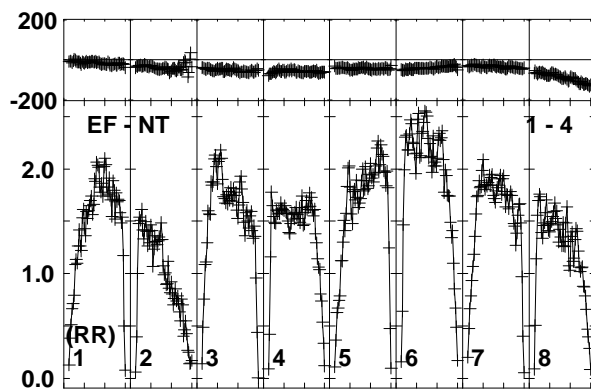
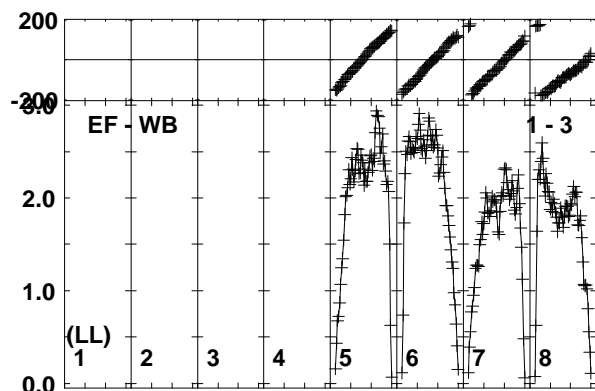
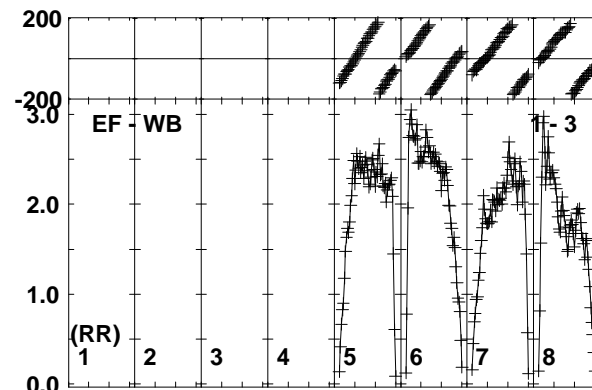
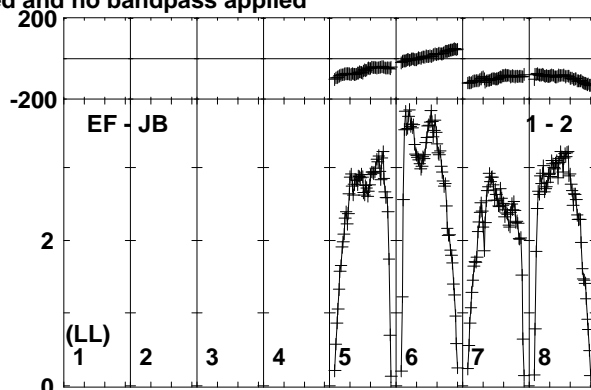
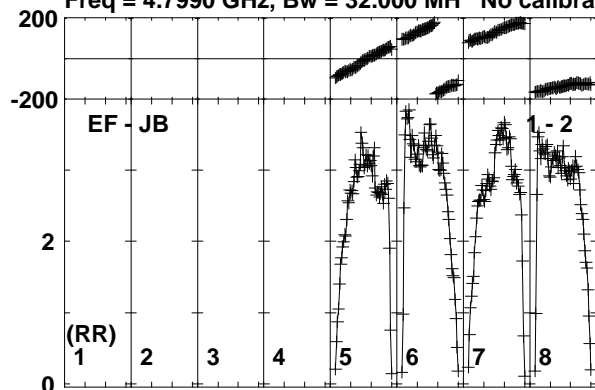

Lower frame: Milli Ampl Jy Top frame: Phas deg
Vector averaged cross-power spectrum Baseline: EF (01) - JB (02)
Timerange: 00/08:11:30 to 00/08:12:28

Plot file version 102 created 03-OCT-2017 13:27:35

J1108+4330 EG096C.UVDATA.1

Freq = 4.7990 GHz, Bw = 32.000 MH No calibration applied and no bandpass applied

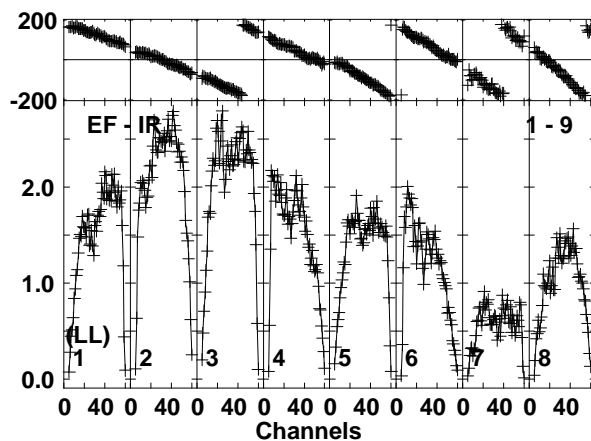
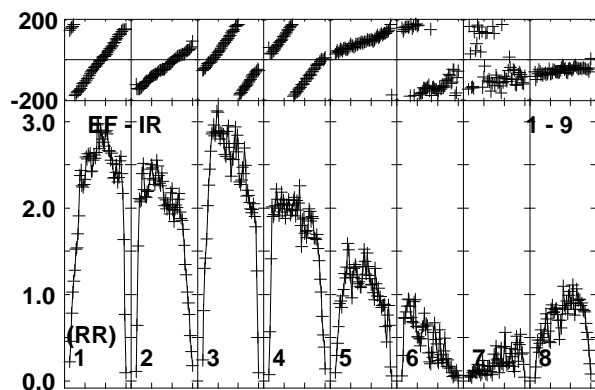
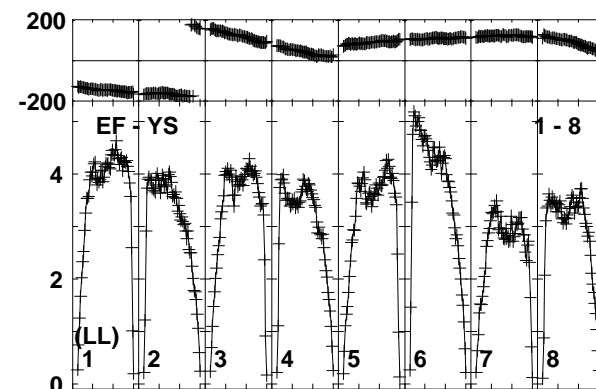
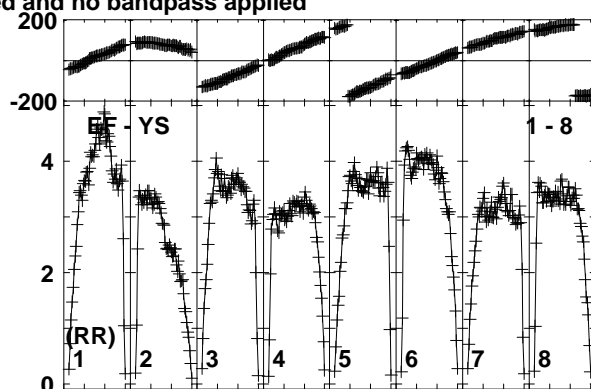
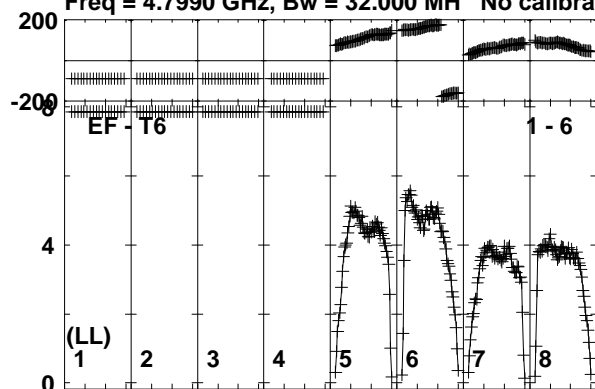

Lower frame: Milli Ampl Jy Top frame: Phas deg
Vector averaged cross-power spectrum Baseline: EF (01) - T6 (06)
Timerange: 00/08:11:30 to 00/08:12:28

Plot file version 103 created 03-OCT-2017 13:27:35

J1112+4301 EG096C.UVDATA.1

Freq = 4.7990 GHz, Bw = 32.000 MH No calibration applied and no bandpass applied

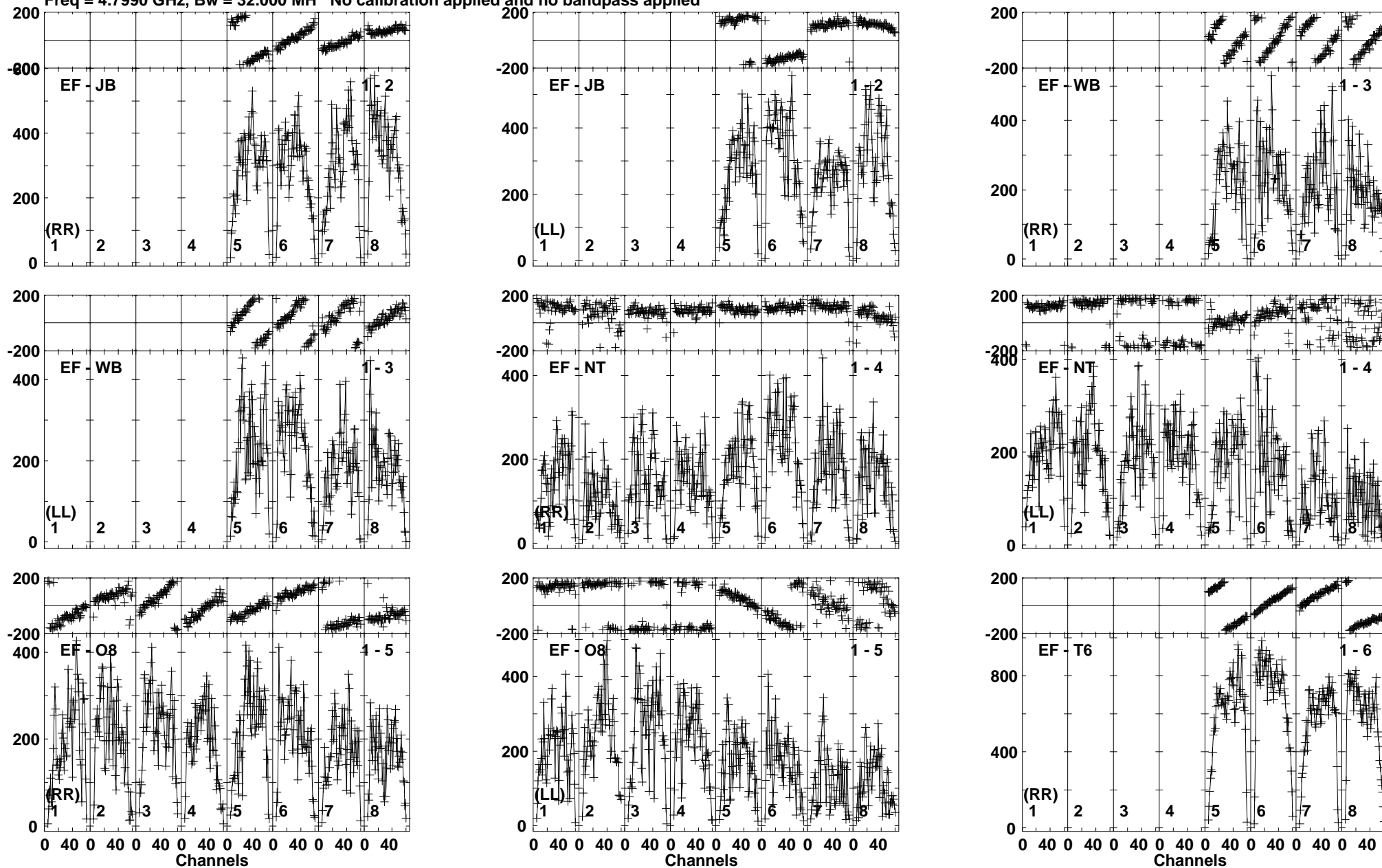

Lower frame: Micro Ampl Jy Top frame: Phas deg
Vector averaged cross-power spectrum Baseline: EF (01) - JB (02)
Timerange: 00/08:12:30 to 00/08:15:59

Plot file version 104 created 03-OCT-2017 13:27:35

J1112+4301 EG096C.UVDATA.1

Freq = 4.7990 GHz, Bw = 32.000 MH No calibration applied and no bandpass applied

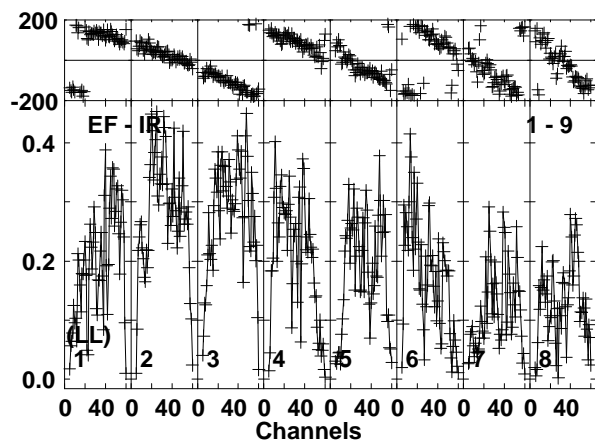
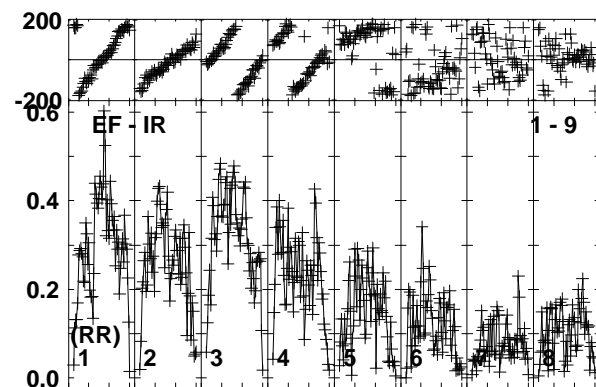
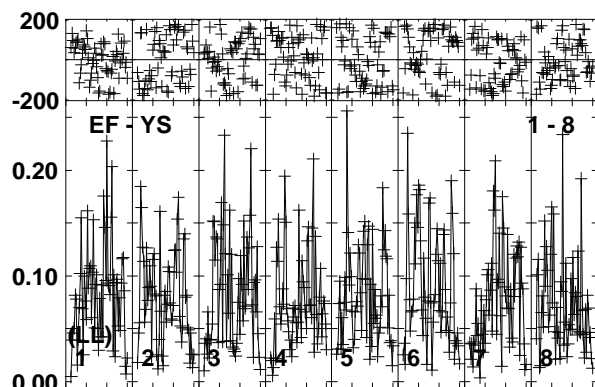
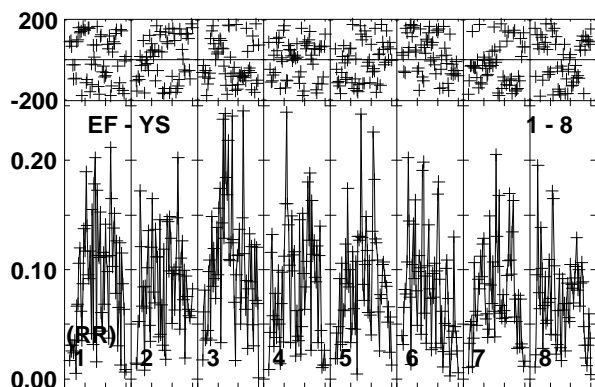
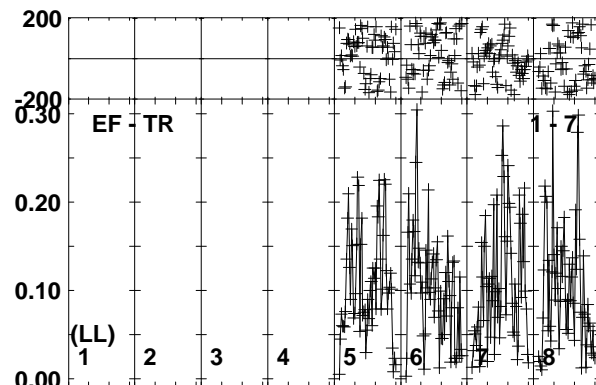
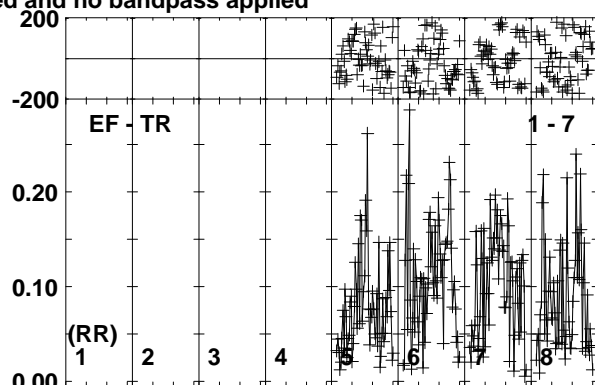
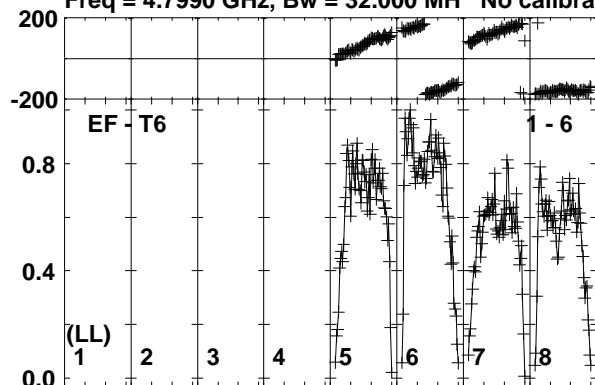

Lower frame: Milli Ampl Jy Top frame: Phas deg
Vector averaged cross-power spectrum Baseline: EF (01) - T6 (06)
Timerange: 00/08:12:30 to 00/08:15:59

Plot file version 105 created 03-OCT-2017 13:27:35

J1108+4330 EG096C.UVDATA.1

Freq = 4.7990 GHz, Bw = 32.000 MH No calibration applied and no bandpass applied

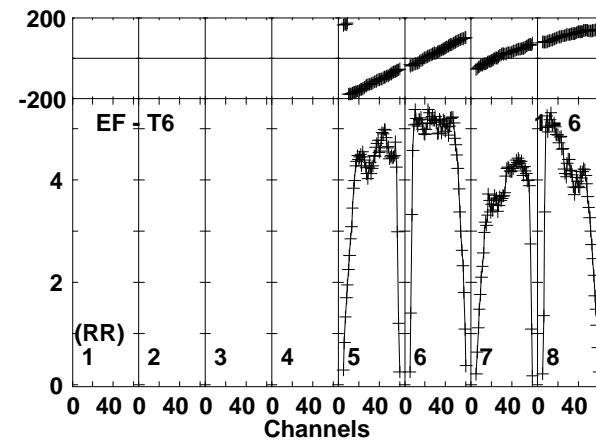
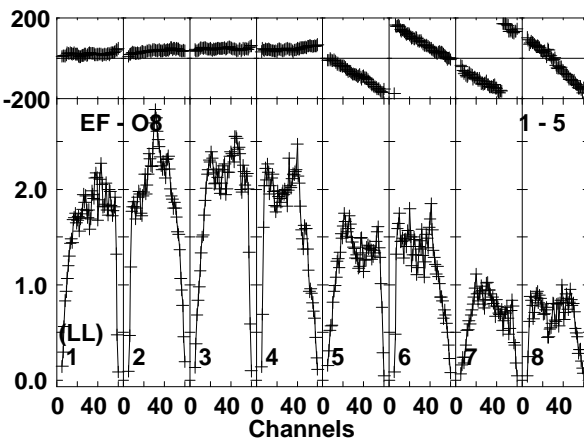
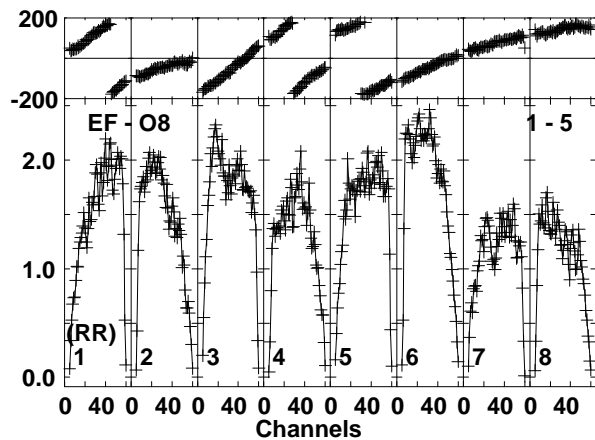
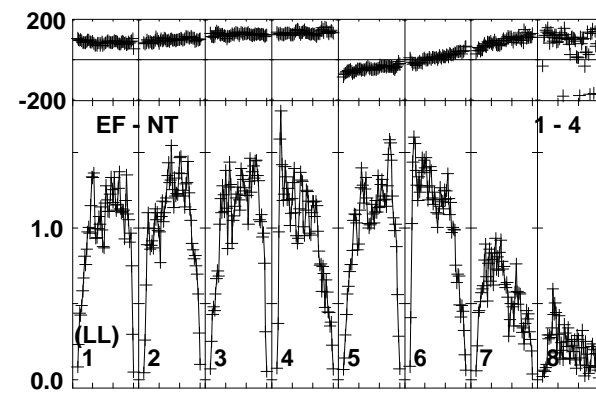
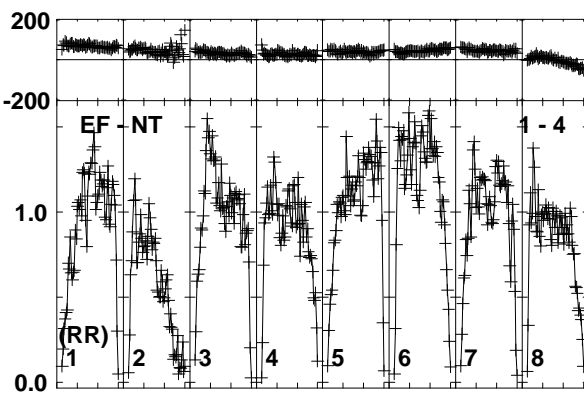
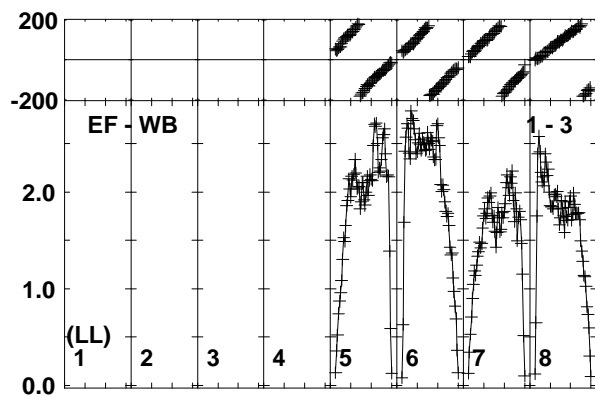
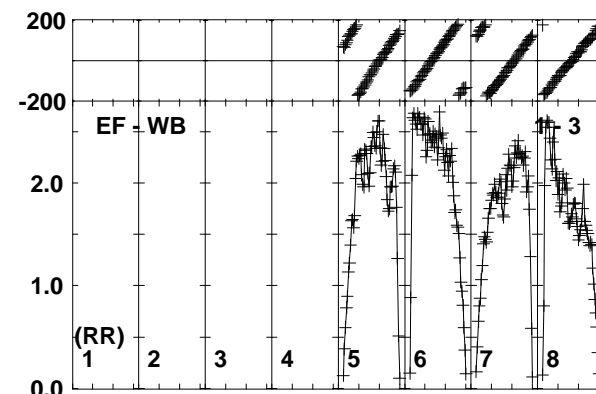
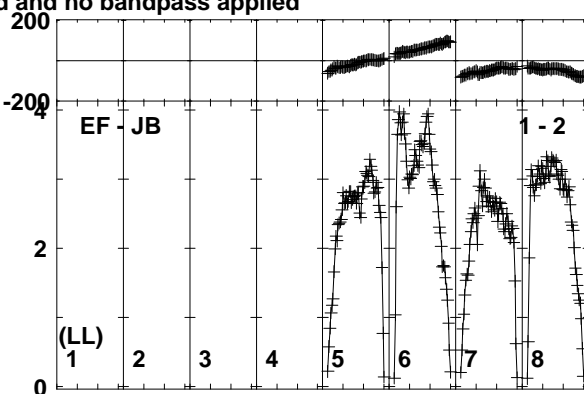
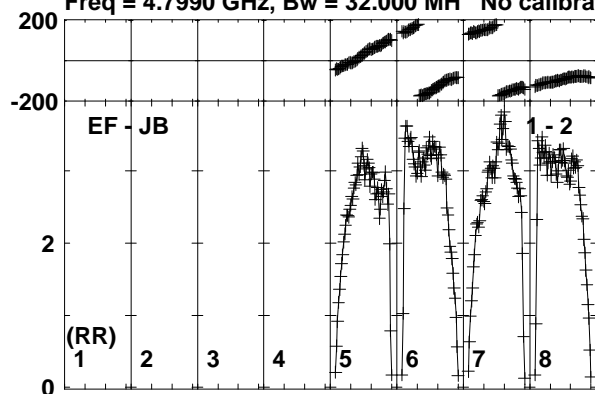

Lower frame: Milli Ampl Jy Top frame: Phas deg
Vector averaged cross-power spectrum Baseline: EF (01) - JB (02)
Timerange: 00/08:16:00 to 00/08:17:29

Plot file version 106 created 03-OCT-2017 13:27:36

J1108+4330 EG096C.UVDATA.1

Freq = 4.7990 GHz, Bw = 32.000 MH No calibration applied and no bandpass applied

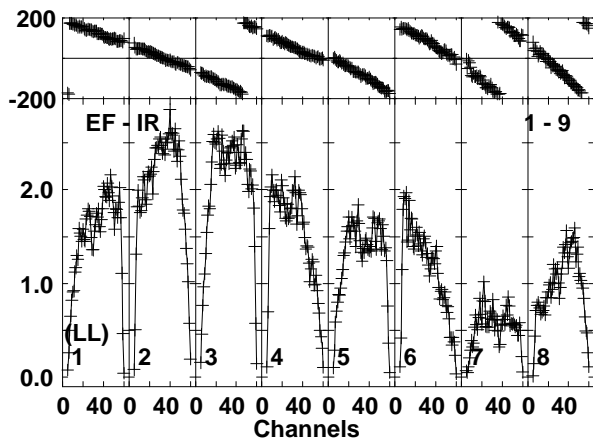
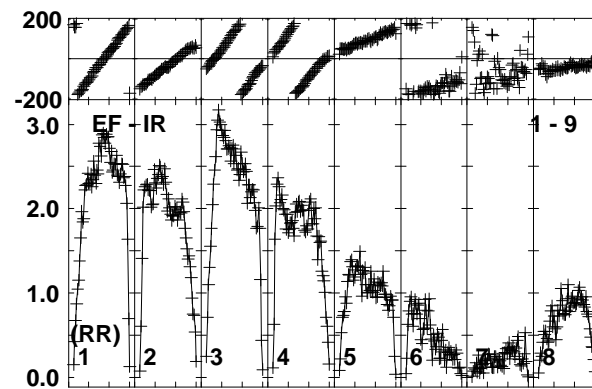
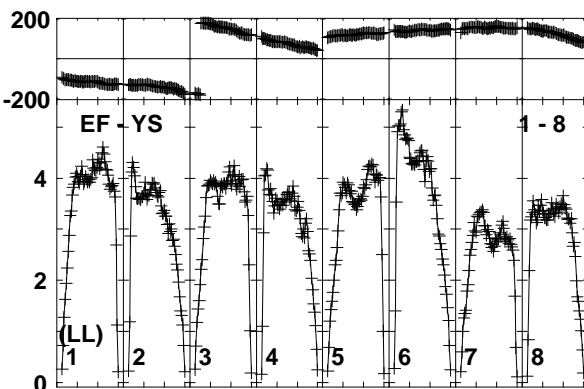
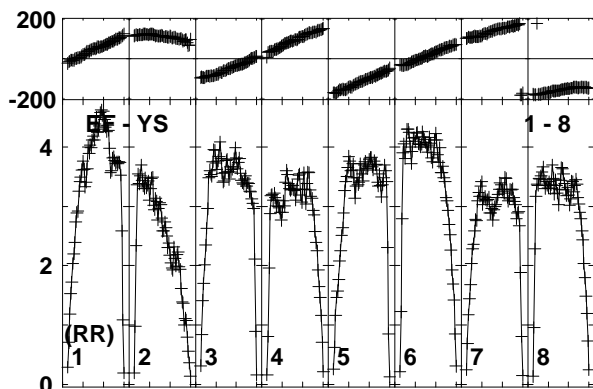
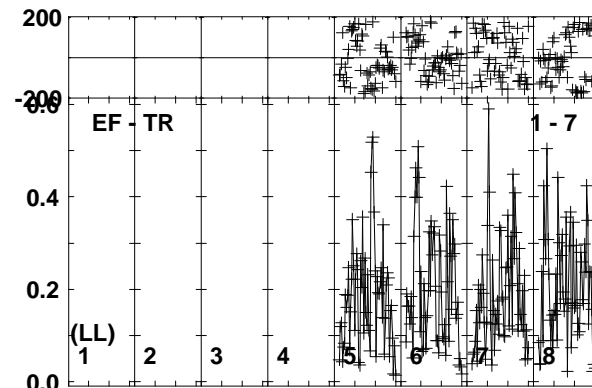
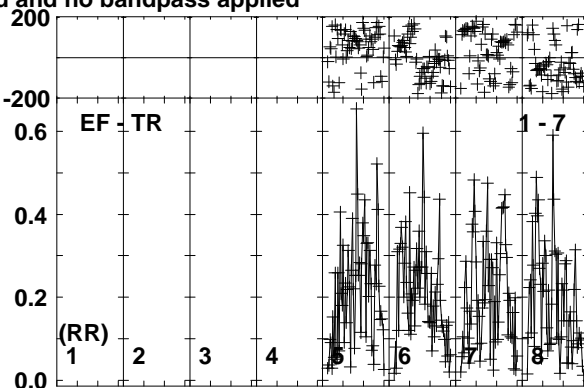
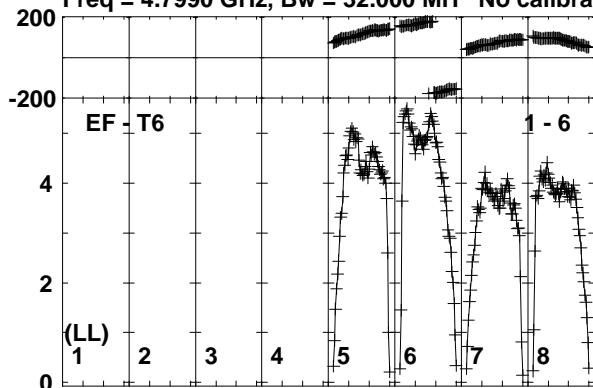

Lower frame: Milli Ampl Jy Top frame: Phas deg
Vector averaged cross-power spectrum Baseline: EF (01) - T6 (06)
Timerange: 00/08:16:00 to 00/08:17:29

Plot file version 107 created 03-OCT-2017 13:27:36

ARUMA EG096C.UVDATA.1

Freq = 4.7990 GHz, Bw = 32.000 MH No calibration applied and no bandpass applied

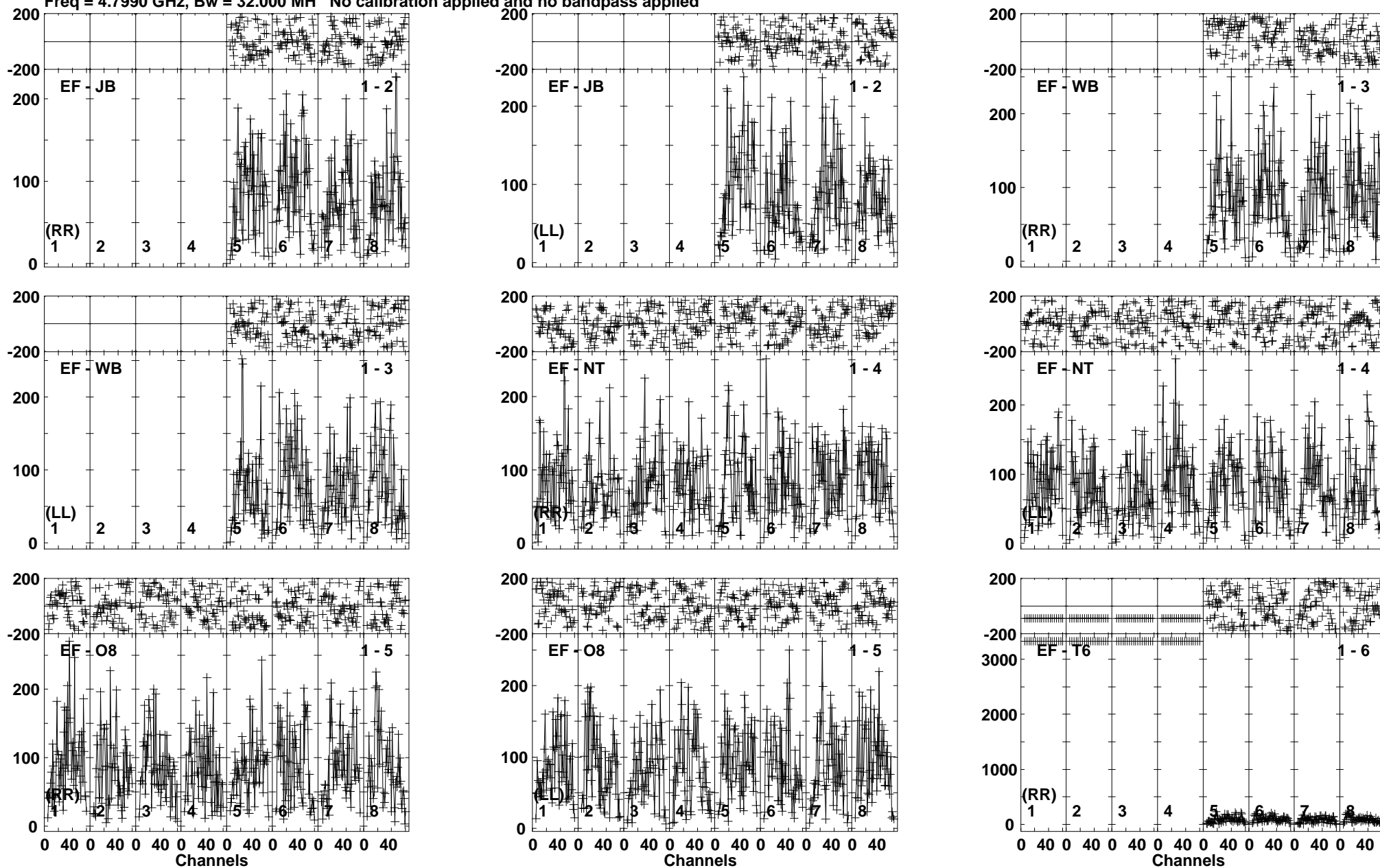

Lower frame: Micro Ampl Jy Top frame: Phas deg
Vector averaged cross-power spectrum Baseline: EF (01) - JB (02)
Timerange: 00/08:17:29 to 00/08:20:59

Plot file version 108 created 03-OCT-2017 13:27:36

ARUMA EG096C.UVDATA.1

Freq = 4.7990 GHz, Bw = 32.000 MH No calibration applied and no bandpass applied

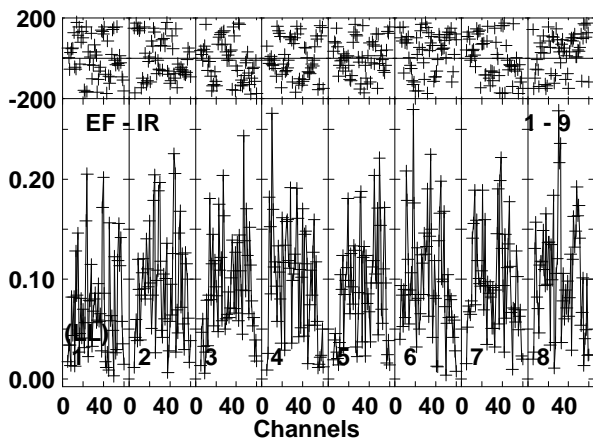
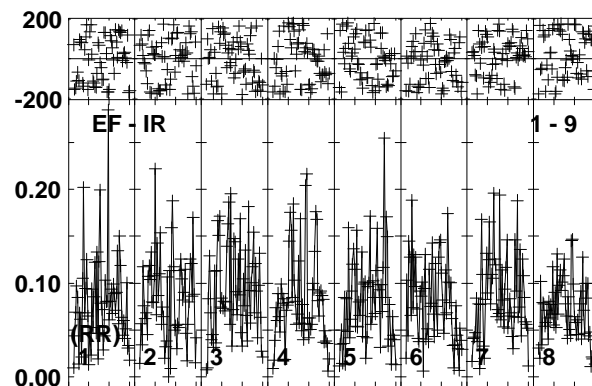
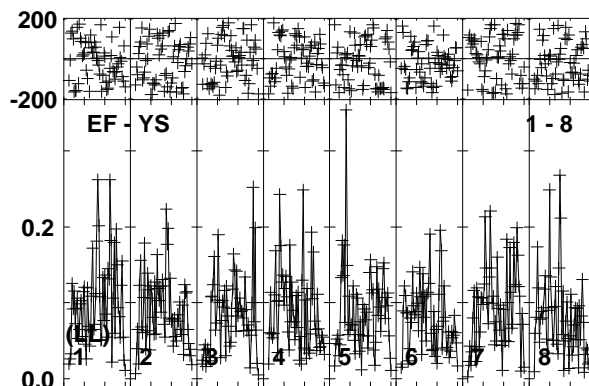
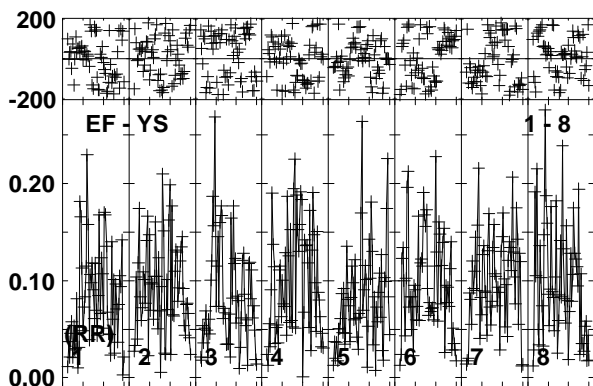
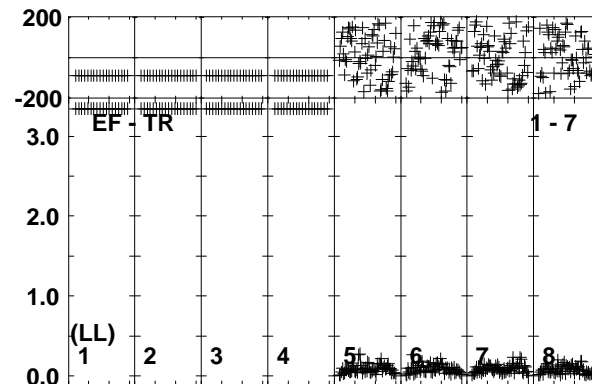
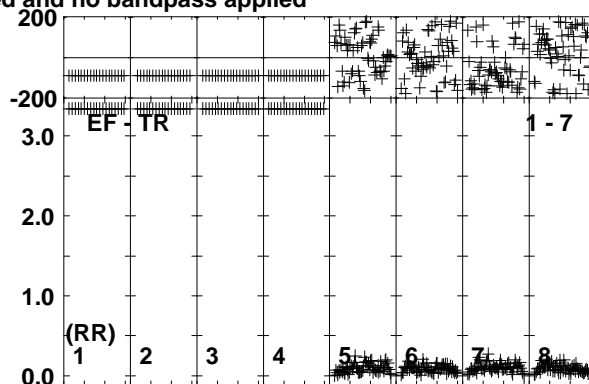
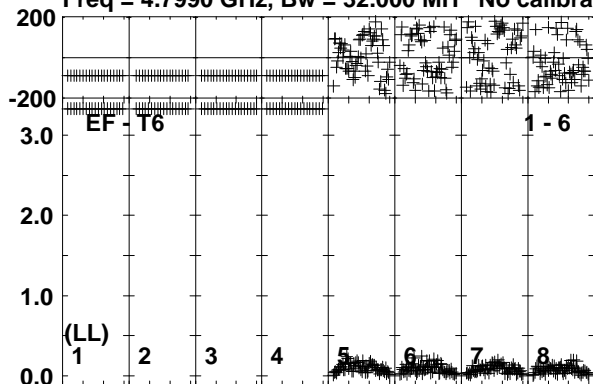

Lower frame: Milli Ampl Jy Top frame: Phas deg
Vector averaged cross-power spectrum Baseline: EF (01) - T6 (06)
Timerange: 00/08:17:29 to 00/08:20:59

Plot file version 109 created 03-OCT-2017 13:27:36

J1108+4330 EG096C.UVDATA.1

Freq = 4.7990 GHz, Bw = 32.000 MH No calibration applied and no bandpass applied

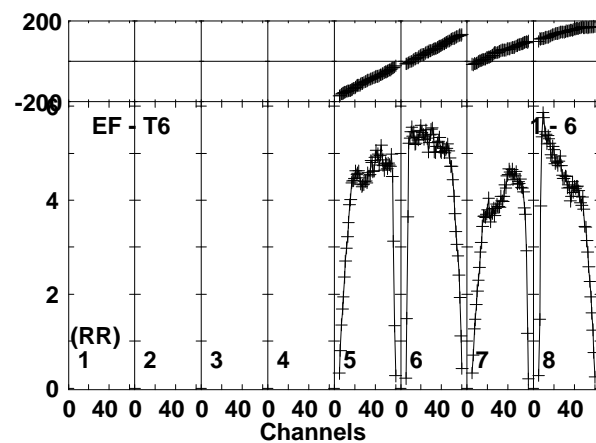
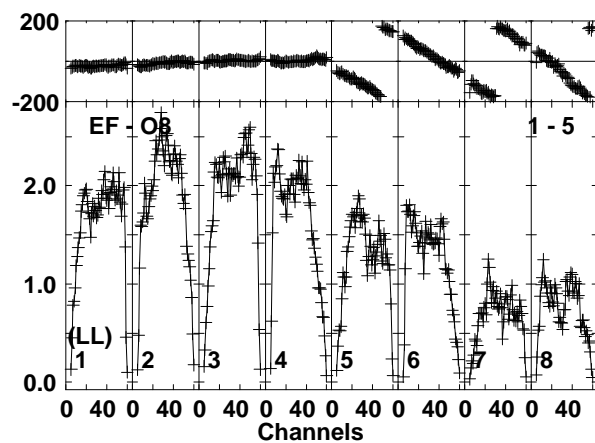
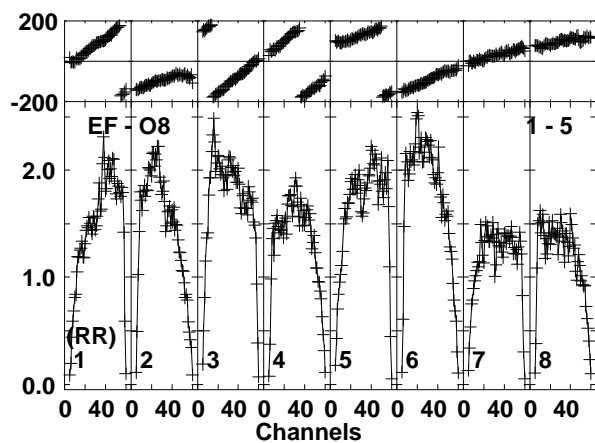
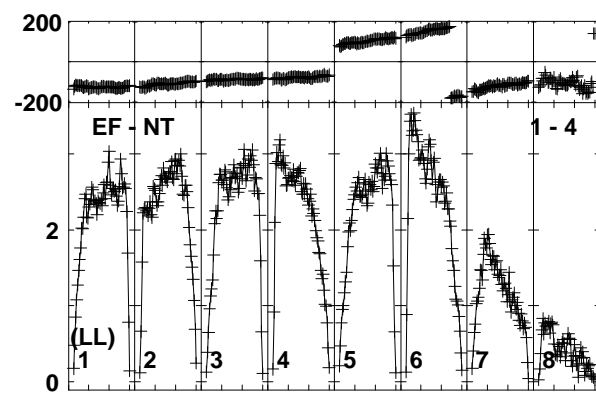
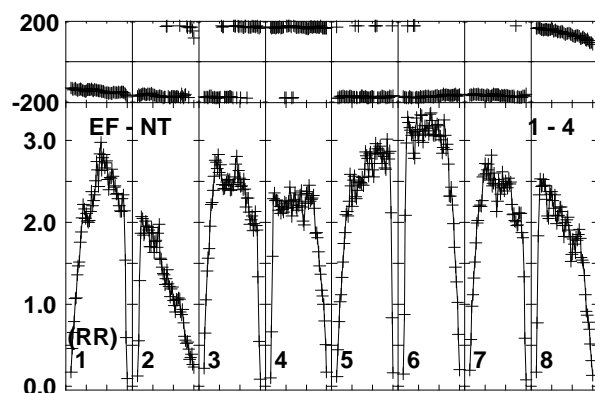
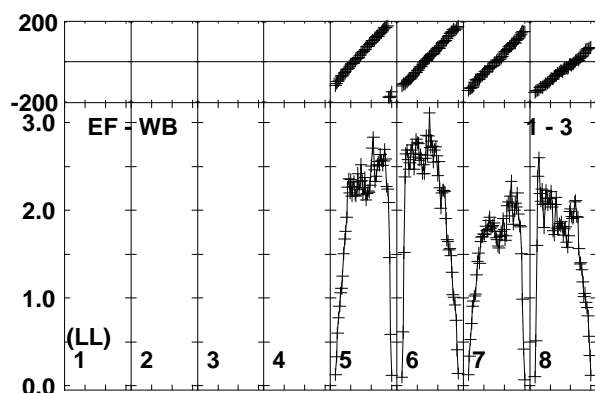
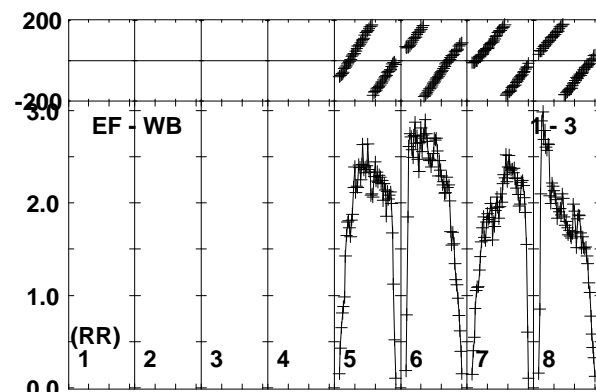
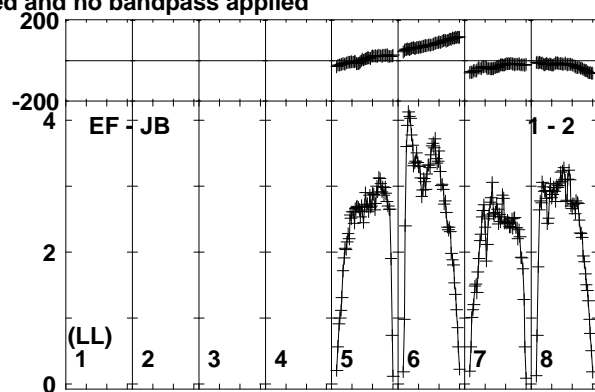
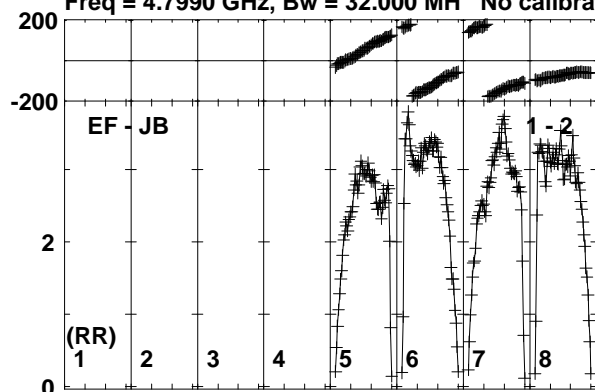

Lower frame: Milli Ampl Jy Top frame: Phas deg
Vector averaged cross-power spectrum Baseline: EF (01) - JB (02)
Timerange: 00/08:21:39 to 00/08:22:39

Plot file version 110 created 03-OCT-2017 13:27:36

J1108+4330 EG096C.UVDATA.1

Freq = 4.7990 GHz, Bw = 32.000 MH No calibration applied and no bandpass applied

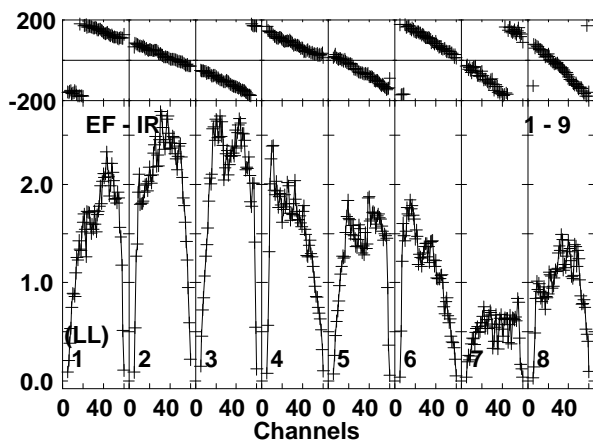
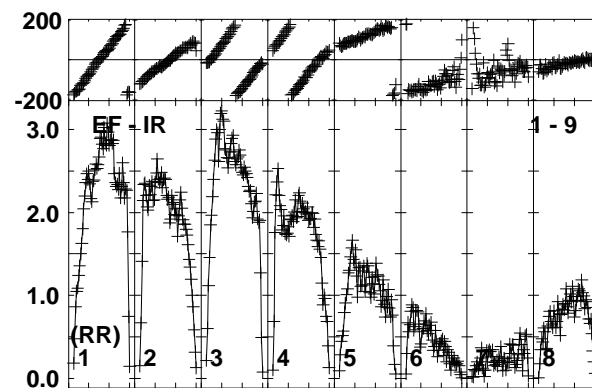
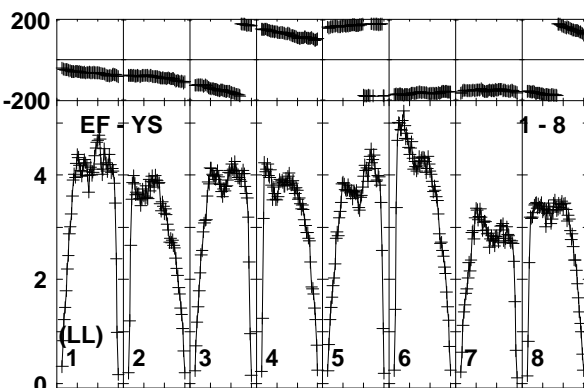
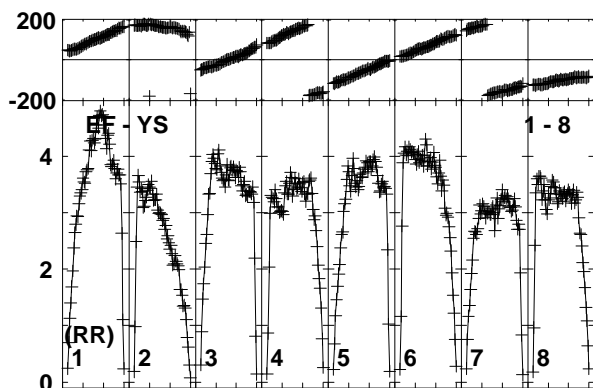
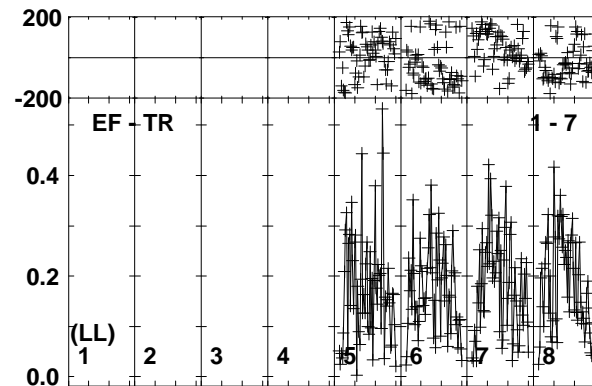
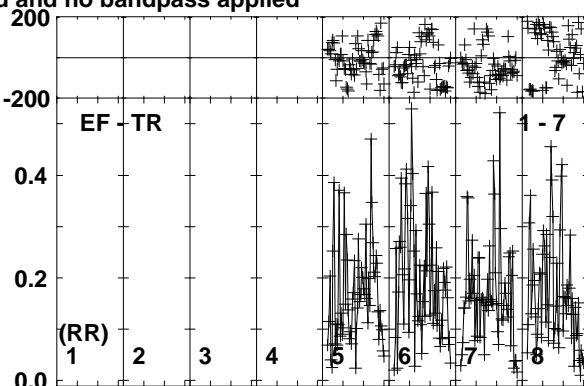
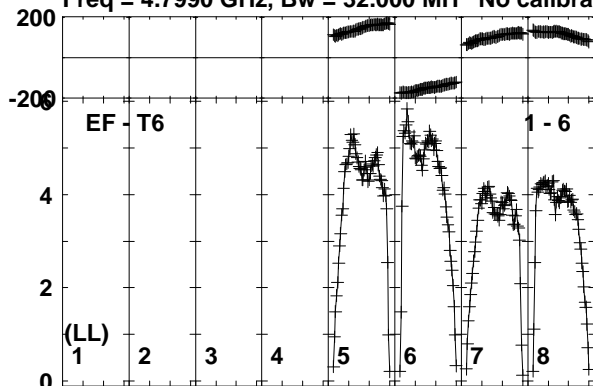

Lower frame: Milli Ampl Jy Top frame: Phas deg
Vector averaged cross-power spectrum Baseline: EF (01) - T6 (06)
Timerange: 00/08:21:39 to 00/08:22:39

Plot file version 111 created 03-OCT-2017 13:27:37

ARUMA EG096C.UVDATA.1

Freq = 4.7990 GHz, Bw = 32.000 MH No calibration applied and no bandpass applied

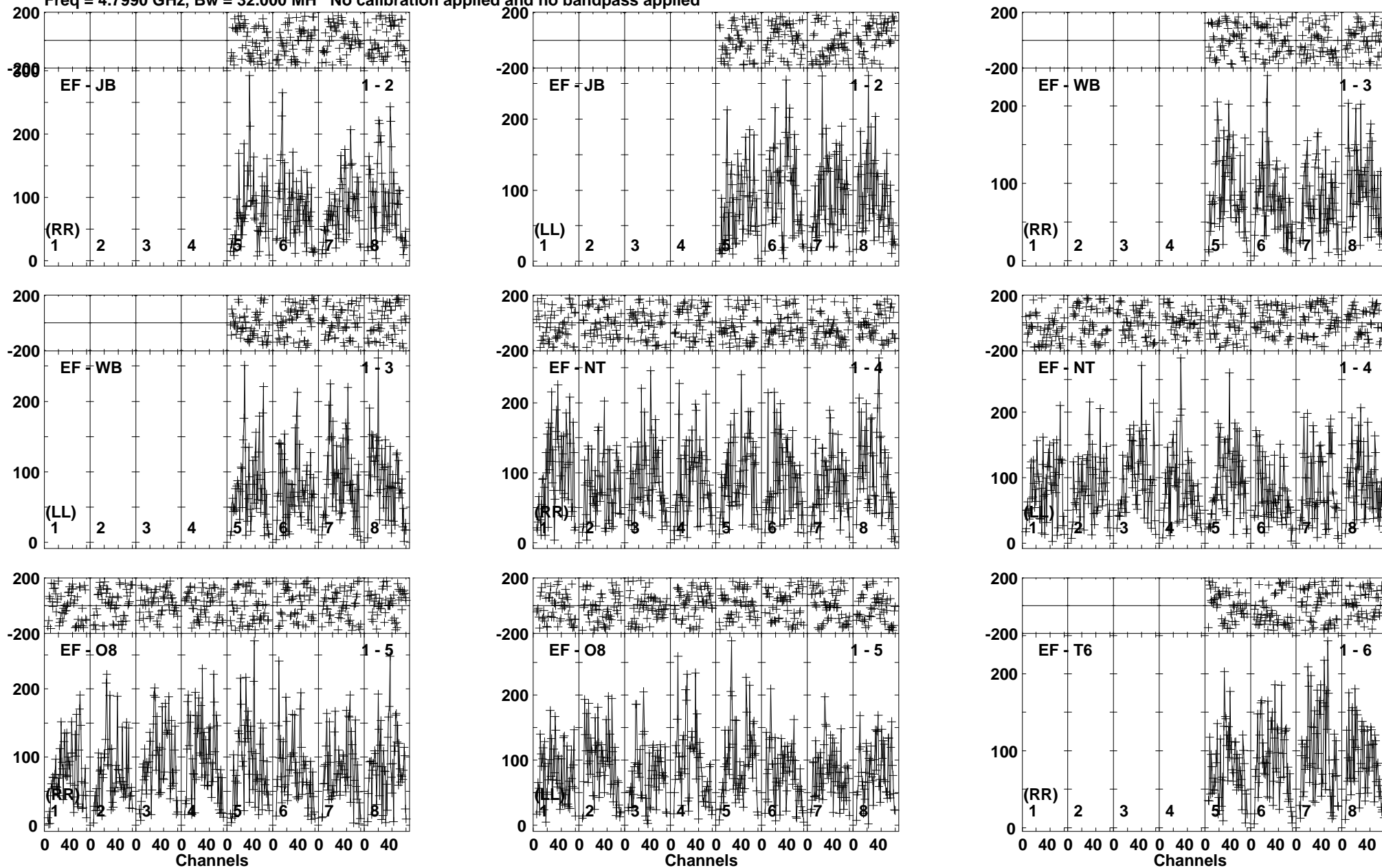

Lower frame: Micro Ampl Jy Top frame: Phas deg
Vector averaged cross-power spectrum Baseline: EF (01) - JB (02)
Timerange: 00/08:22:39 to 00/08:26:09

Plot file version 112 created 03-OCT-2017 13:27:37

ARUMA EG096C.UVDATA.1

Freq = 4.7990 GHz, Bw = 32.000 MH No calibration applied and no bandpass applied

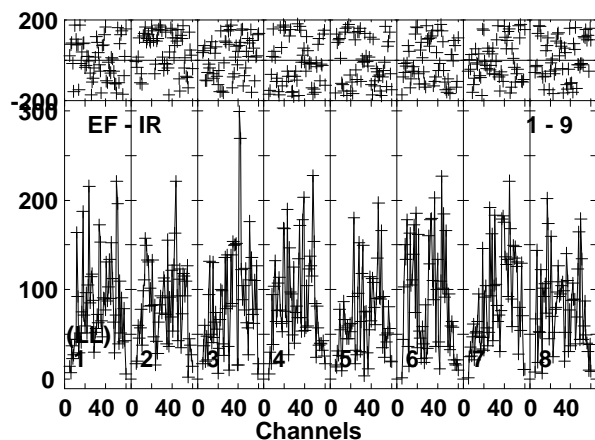
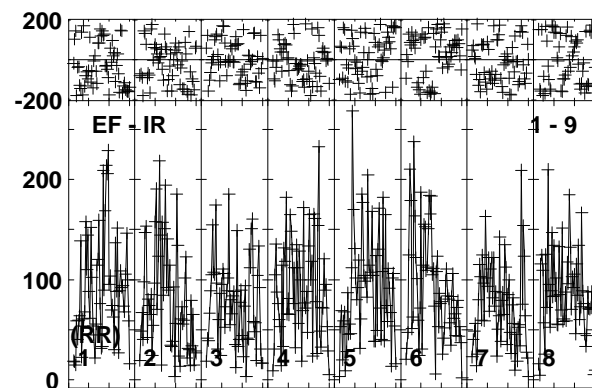
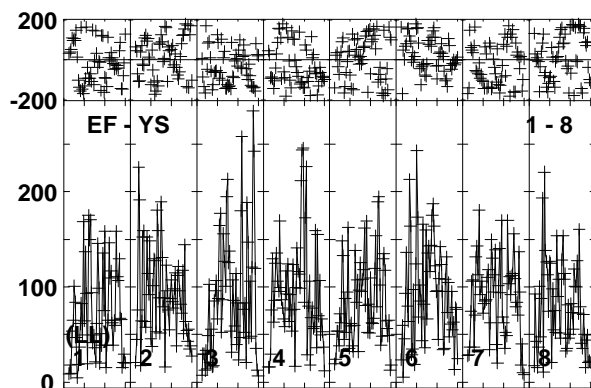
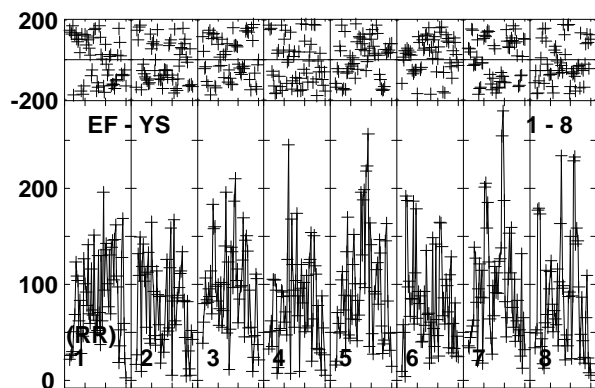
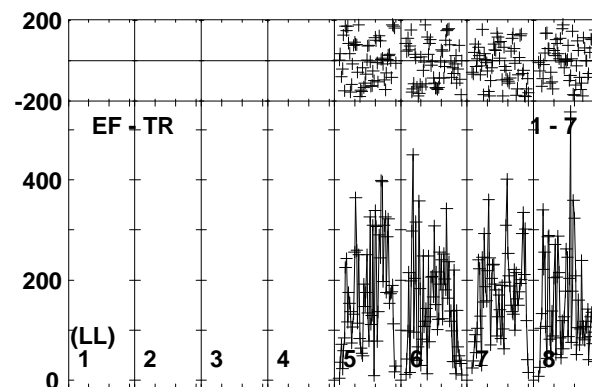
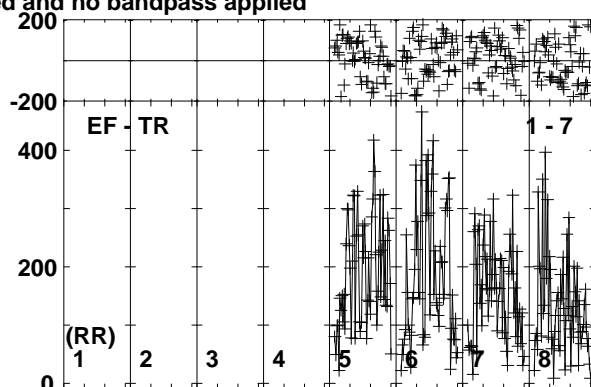
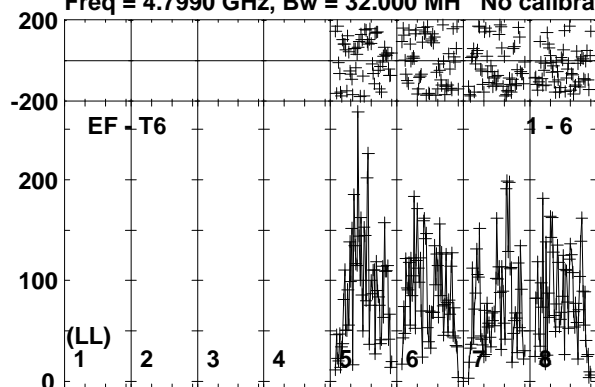

Lower frame: Micro Ampl Jy Top frame: Phas deg
Vector averaged cross-power spectrum Baseline: EF (01) - T6 (06)
Timerange: 00/08:22:39 to 00/08:26:09

Plot file version 113 created 03-OCT-2017 13:27:37

J1108+4330 EG096C.UVDATA.1

Freq = 4.7990 GHz, Bw = 32.000 MH No calibration applied and no bandpass applied

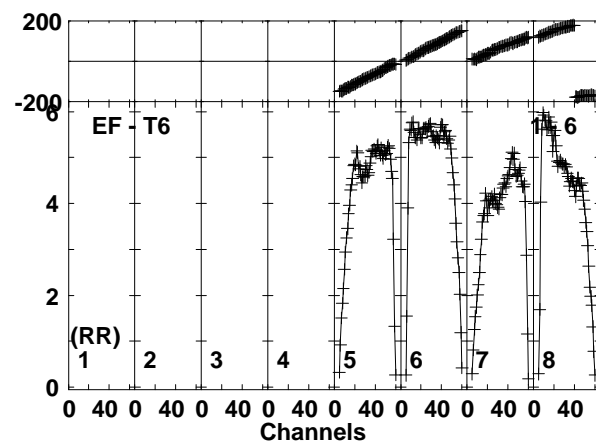
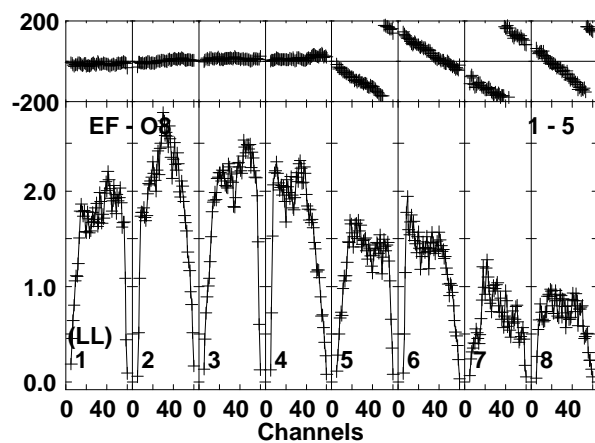
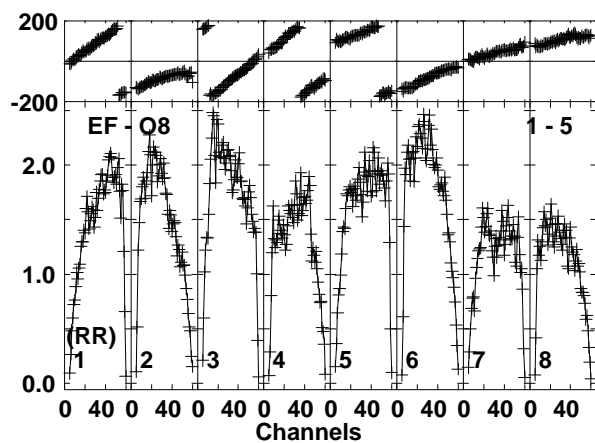
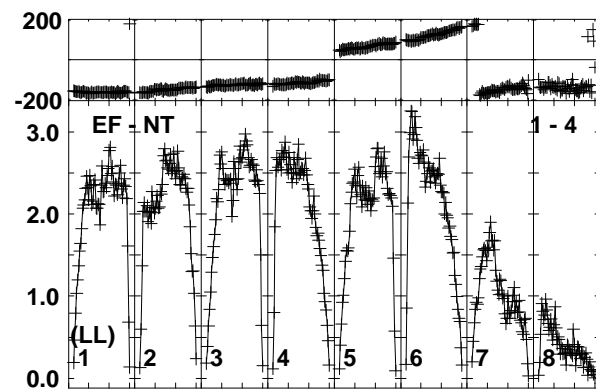
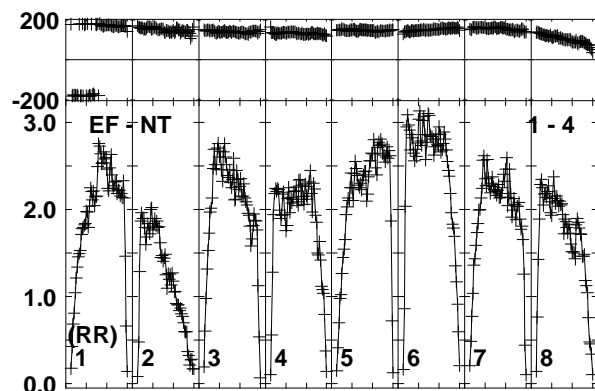
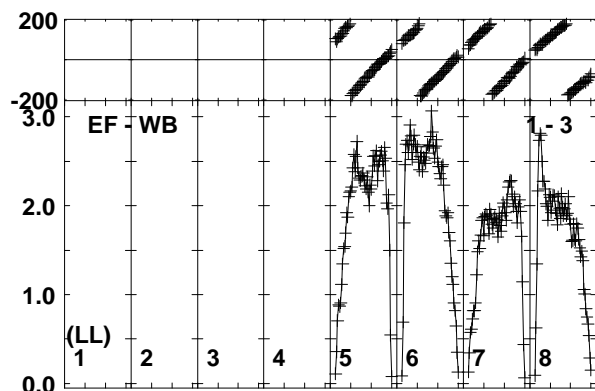
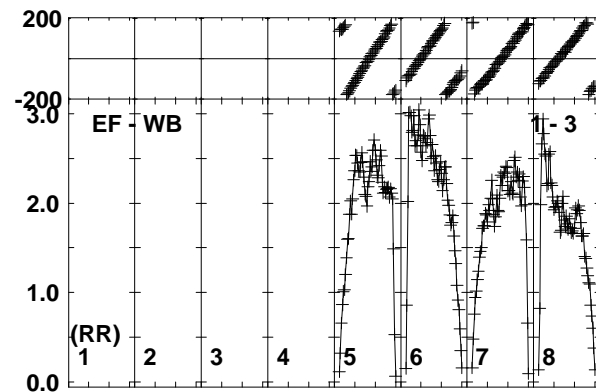
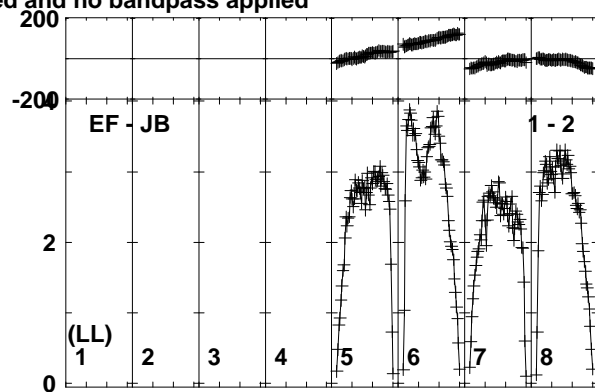
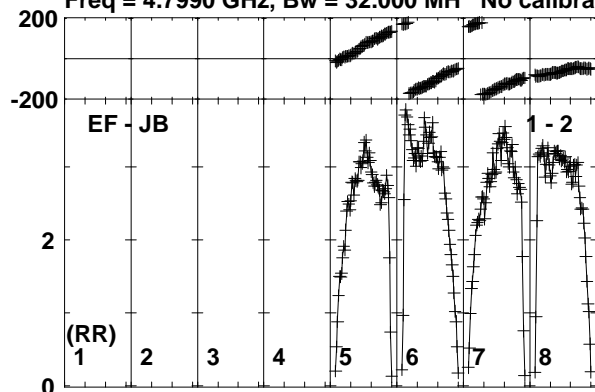

Lower frame: Milli Ampl Jy Top frame: Phas deg
Vector averaged cross-power spectrum Baseline: EF (01) - JB (02)
Timerange: 00/08:26:09 to 00/08:27:38

Plot file version 114 created 03-OCT-2017 13:27:37

J1108+4330 EG096C.UVDATA.1

Freq = 4.7990 GHz, Bw = 32.000 MH No calibration applied and no bandpass applied

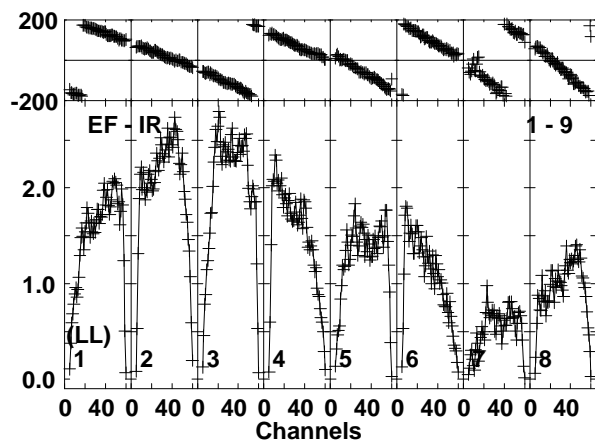
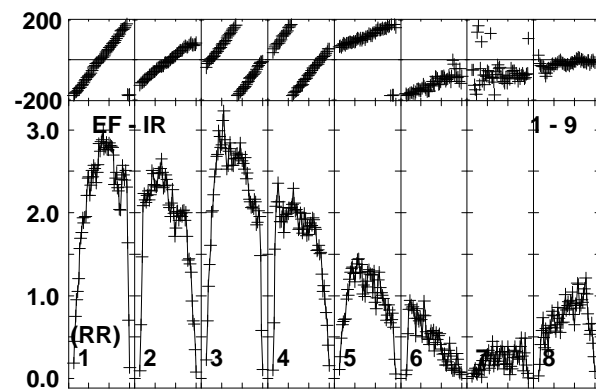
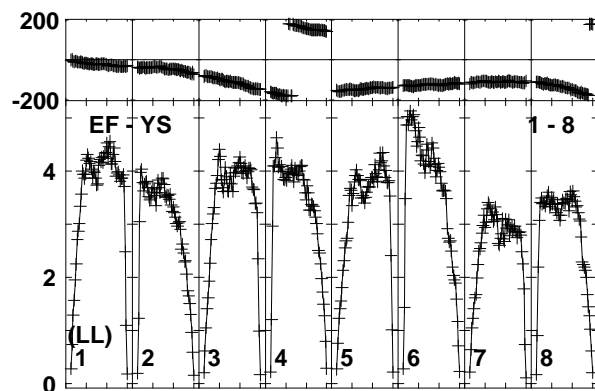
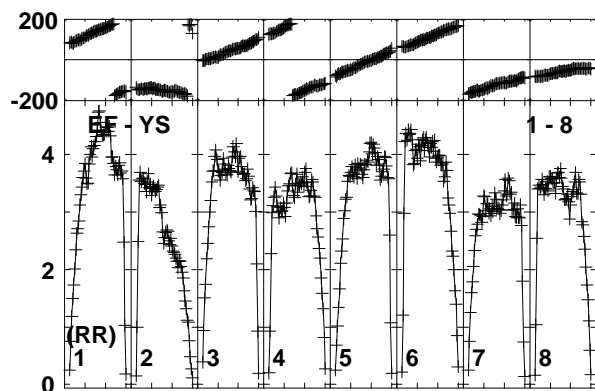
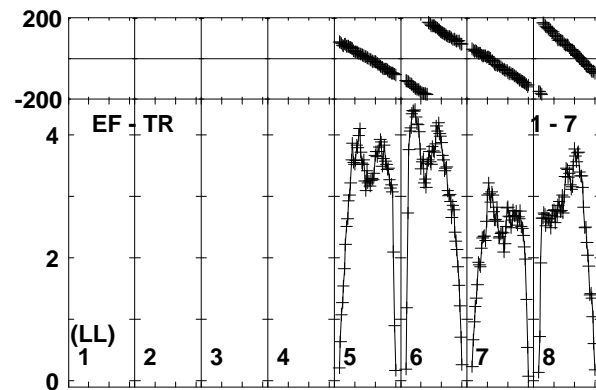
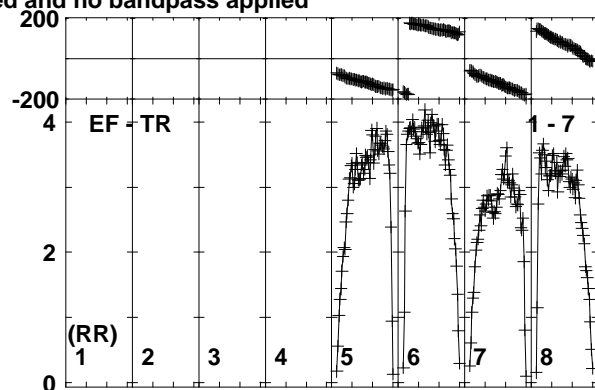
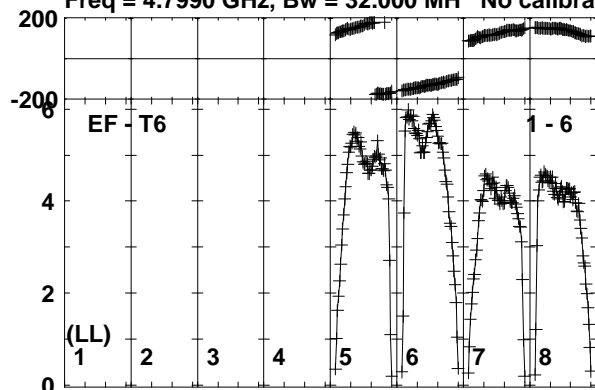

Lower frame: Milli Ampl Jy Top frame: Phas deg
Vector averaged cross-power spectrum Baseline: EF (01) - T6 (06)
Timerange: 00/08:26:09 to 00/08:27:38

Plot file version 115 created 03-OCT-2017 13:27:38

ARUMA EG096C.UVDATA.1

Freq = 4.7990 GHz, Bw = 32.000 MH No calibration applied and no bandpass applied

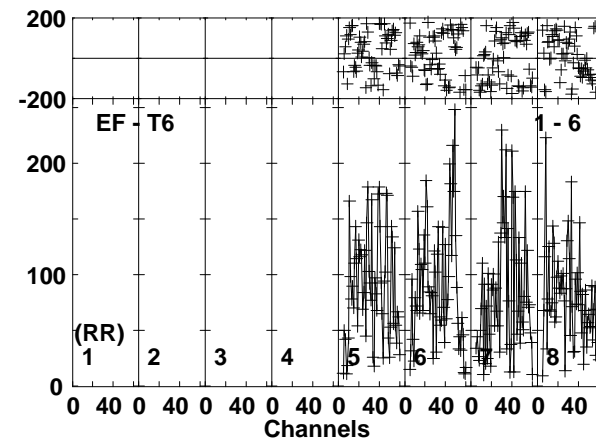
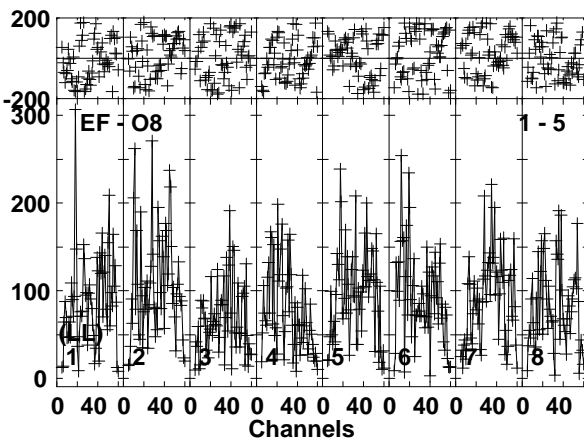
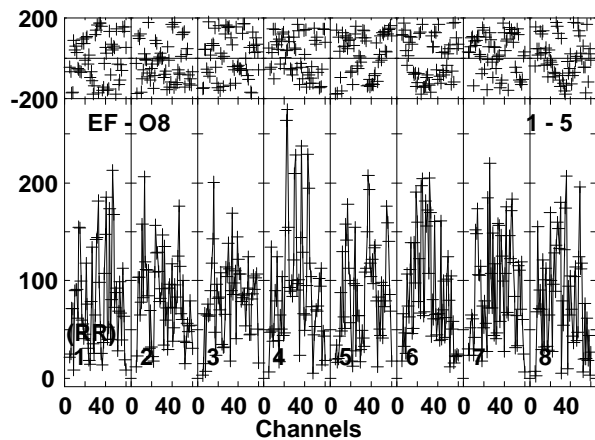
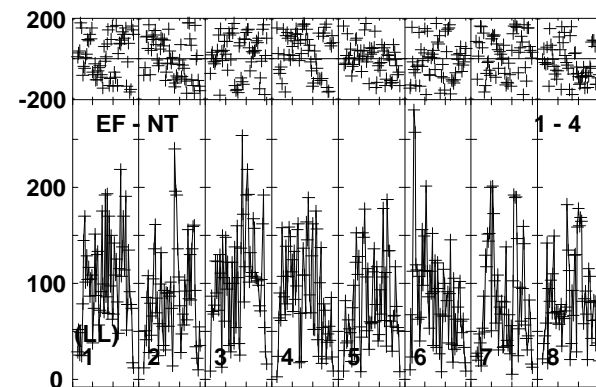
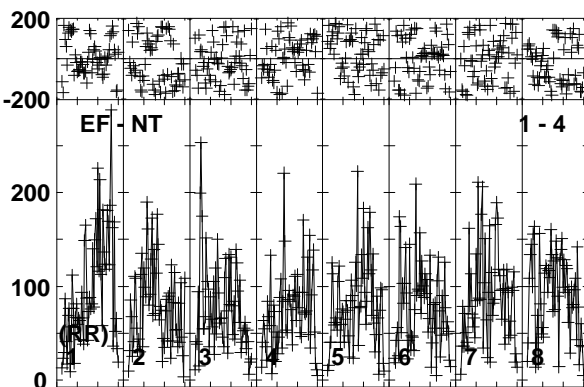
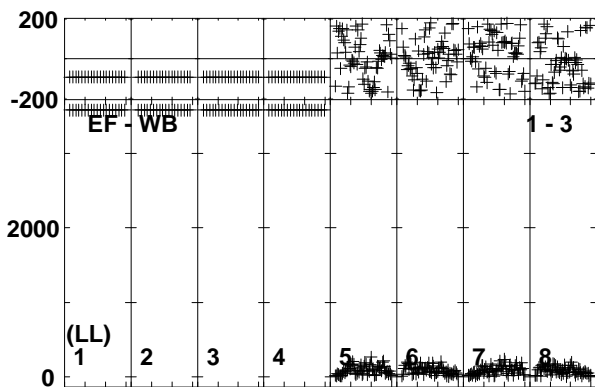
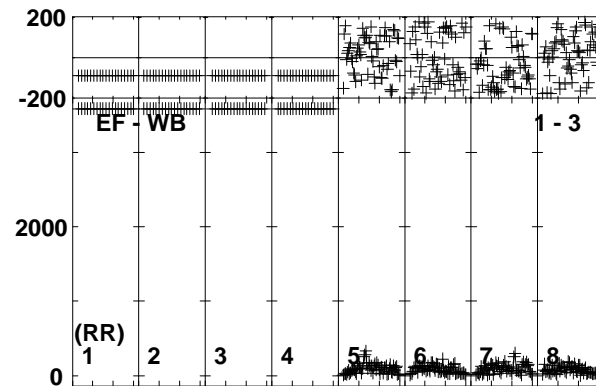
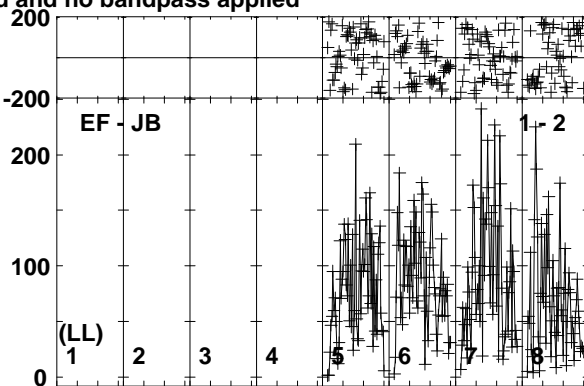
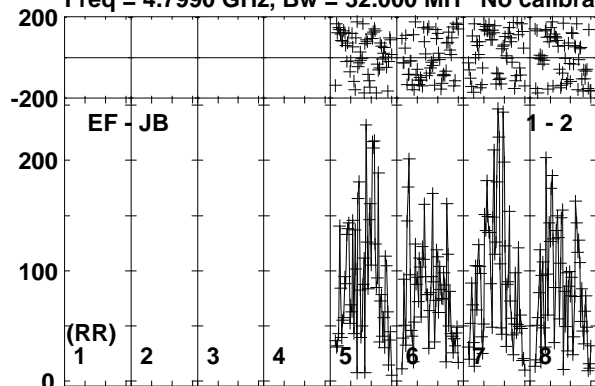

Lower frame: Micro Ampl Jy Top frame: Phas deg
Vector averaged cross-power spectrum Baseline: EF (01) - JB (02)
Timerange: 00/08:27:39 to 00/08:31:08

Plot file version 116 created 03-OCT-2017 13:27:38

ARUMA EG096C.UVDATA.1

Freq = 4.7990 GHz, Bw = 32.000 MH No calibration applied and no bandpass applied

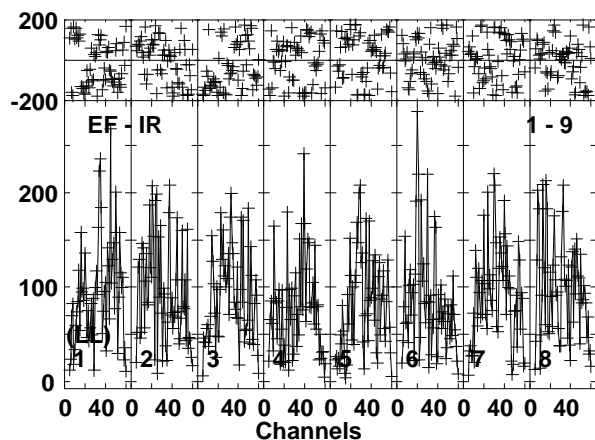
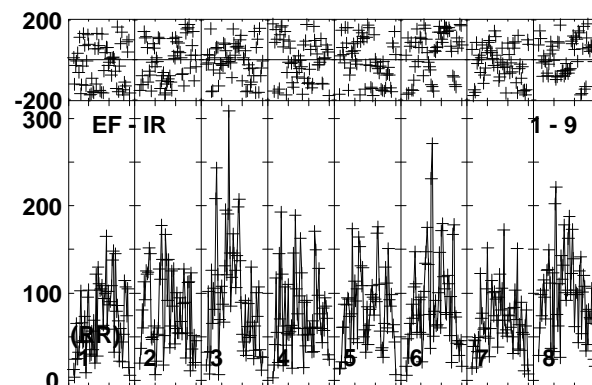
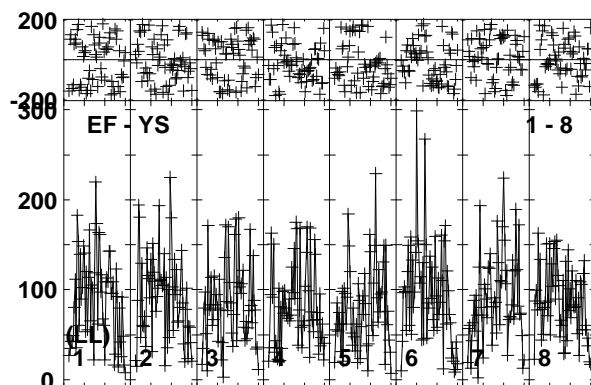
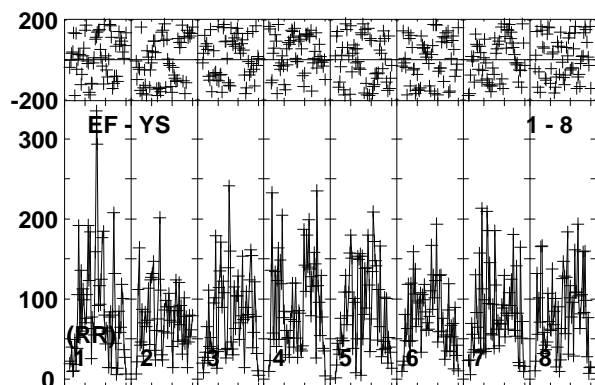
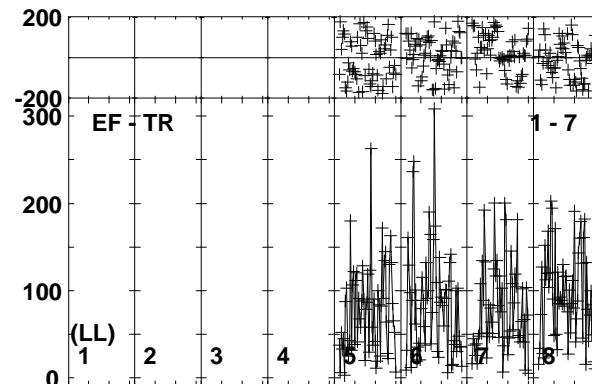
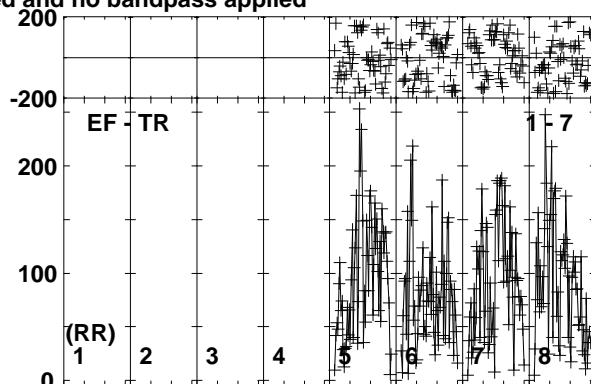
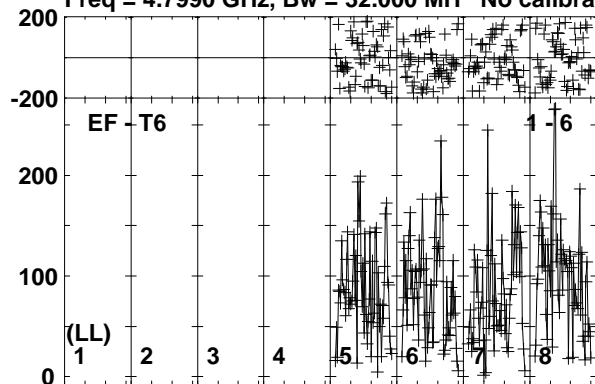

Lower frame: Micro Ampl Jy Top frame: Phas deg
Vector averaged cross-power spectrum Baseline: EF (01) - T6 (06)
Timerange: 00/08:27:39 to 00/08:31:08

Plot file version 117 created 03-OCT-2017 13:27:38

J1108+4330 EG096C.UVDATA.1

Freq = 4.7990 GHz, Bw = 32.000 MH No calibration applied and no bandpass applied

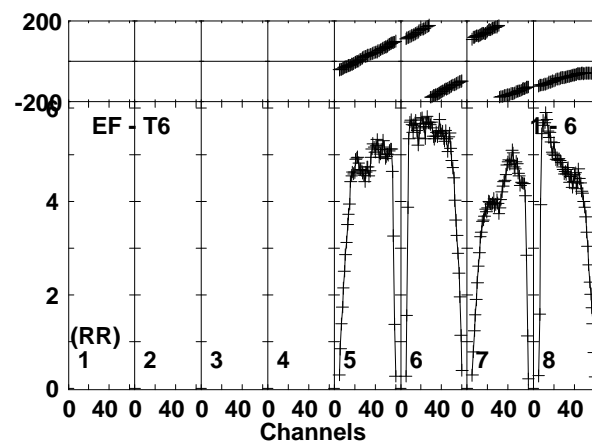
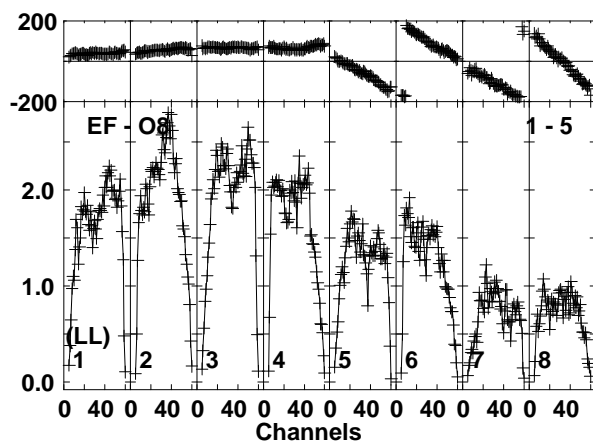
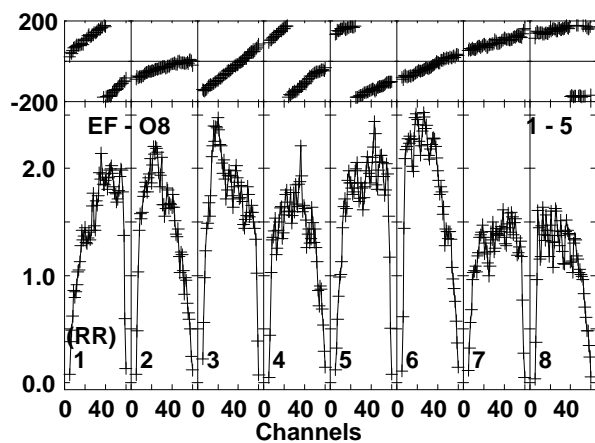
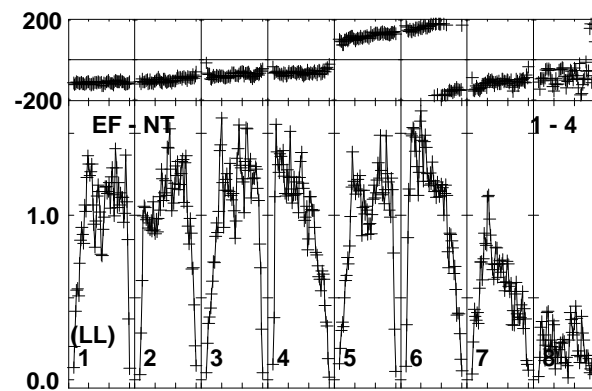
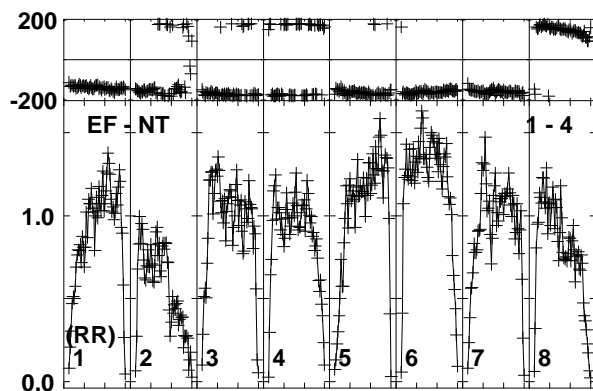
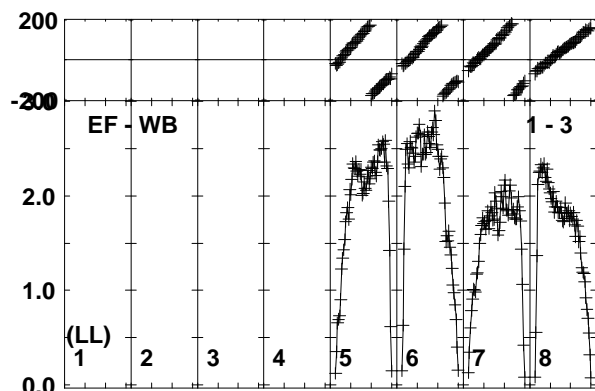
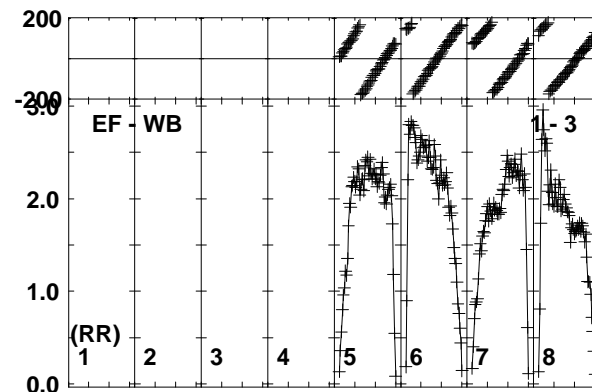
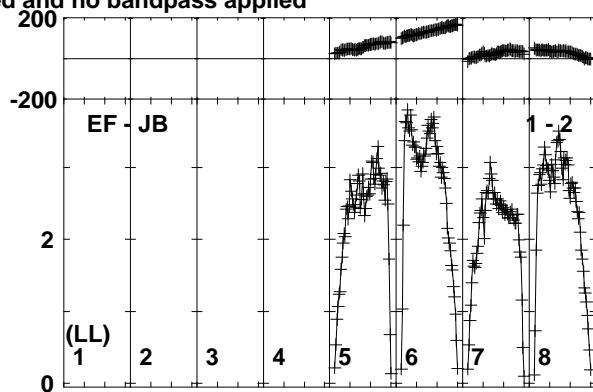
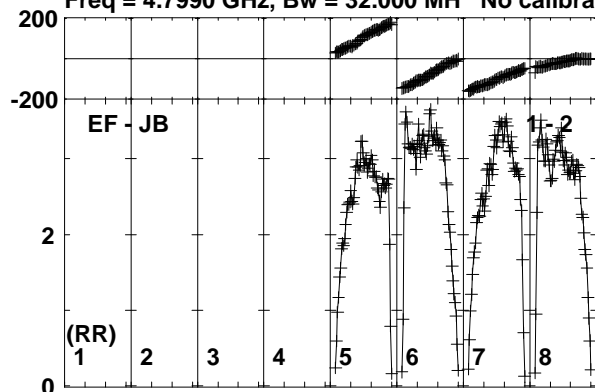

Lower frame: Milli Ampl Jy Top frame: Phas deg
Vector averaged cross-power spectrum Baseline: EF (01) - JB (02)
Timerange: 00/08:31:50 to 00/08:32:48

Plot file version 118 created 03-OCT-2017 13:27:38

J1108+4330 EG096C.UVDATA.1

Freq = 4.7990 GHz, Bw = 32.000 MH No calibration applied and no bandpass applied

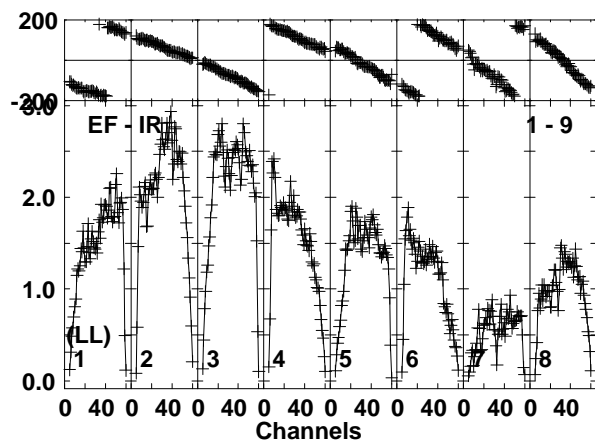
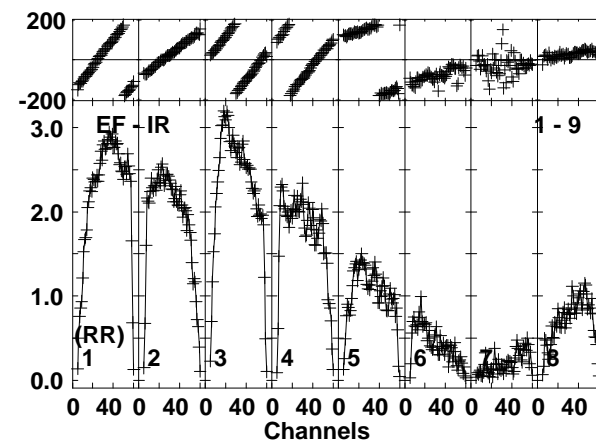
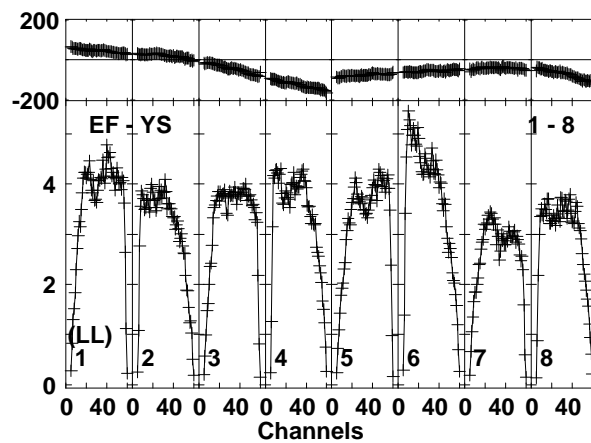
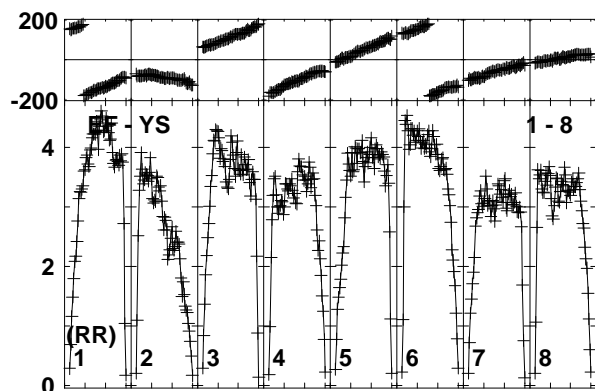
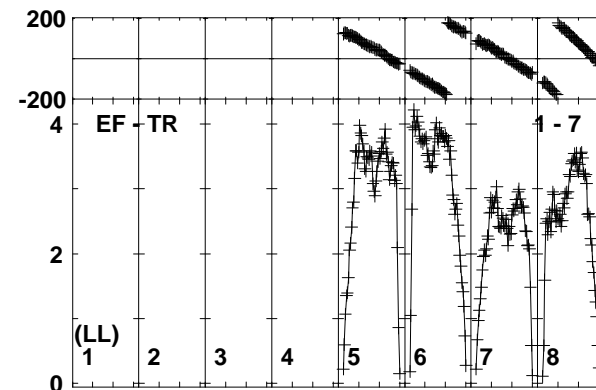
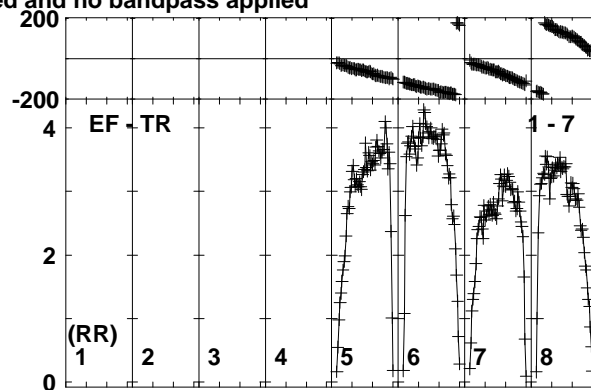
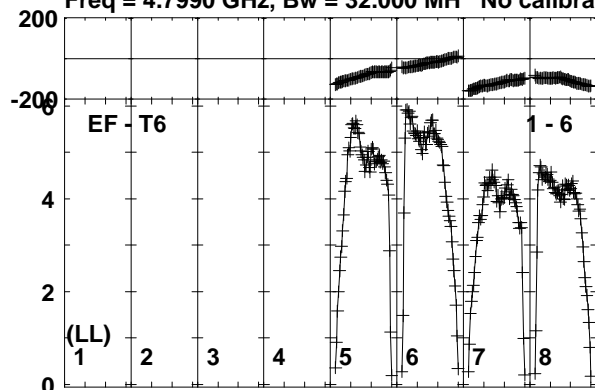

Lower frame: Milli Ampl Jy Top frame: Phas deg
Vector averaged cross-power spectrum Baseline: EF (01) - T6 (06)
Timerange: 00/08:31:50 to 00/08:32:48

Plot file version 119 created 03-OCT-2017 13:27:38

ARUMA EG096C.UVDATA.1

Freq = 4.7990 GHz, Bw = 32.000 MH No calibration applied and no bandpass applied

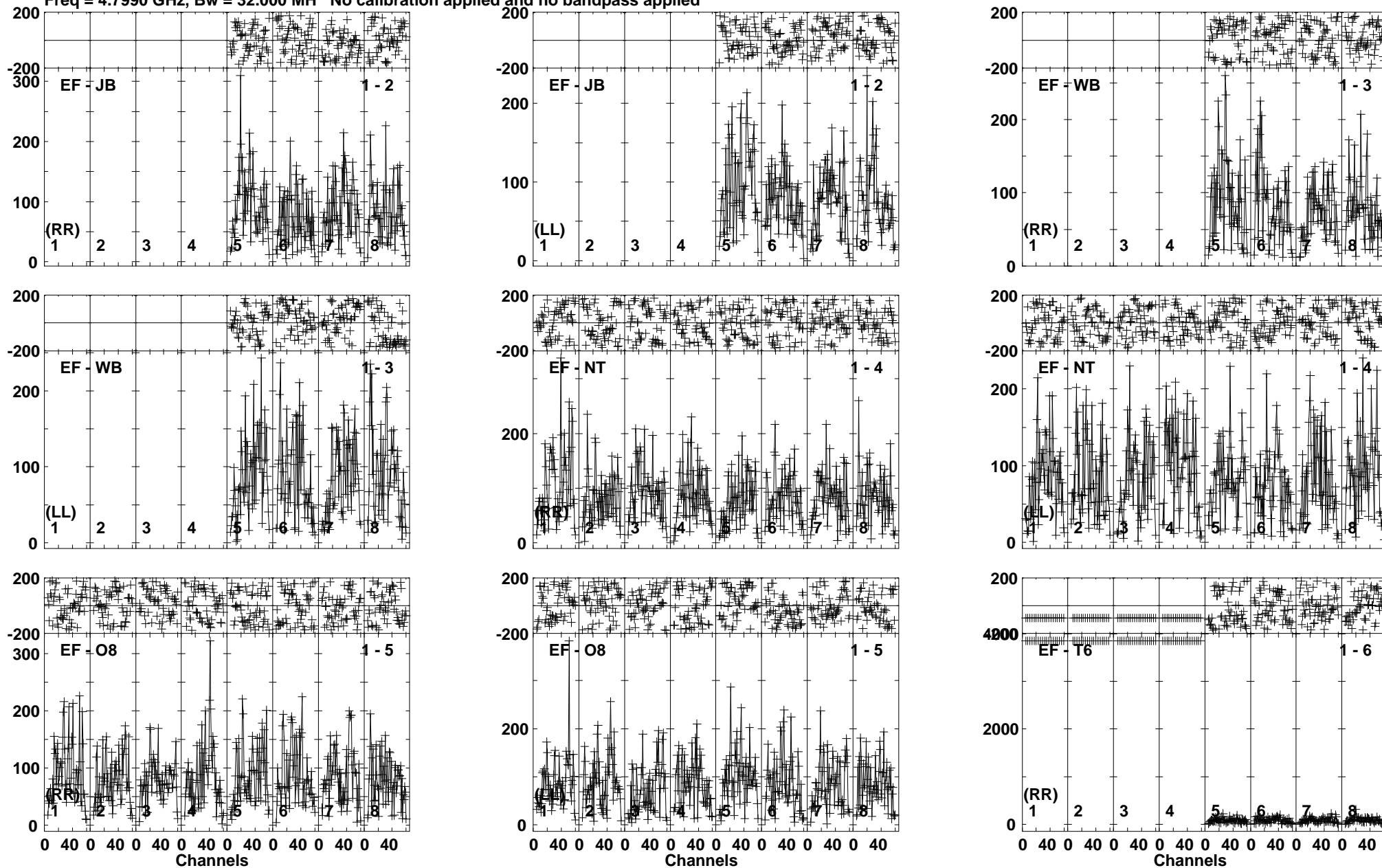

Lower frame: Micro Ampl Jy Top frame: Phas deg
Vector averaged cross-power spectrum Baseline: EF (01) - JB (02)
Timerange: 00/08:32:49 to 00/08:36:18

Plot file version 120 created 03-OCT-2017 13:27:39
ARUMA EG096C.UVDATA.1
Freq = 4.7990 GHz, Bw = 32.000 MH No calibration applied and no bandpass applied

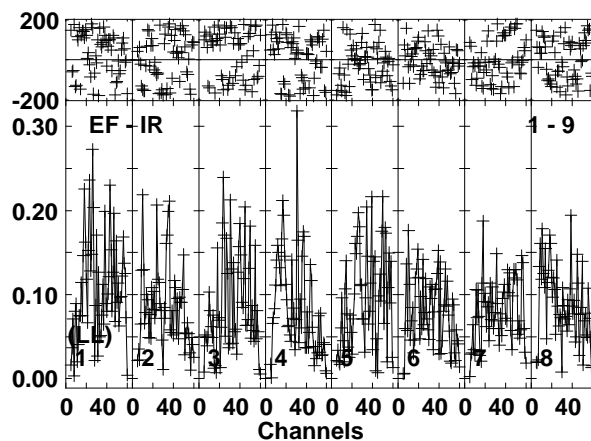
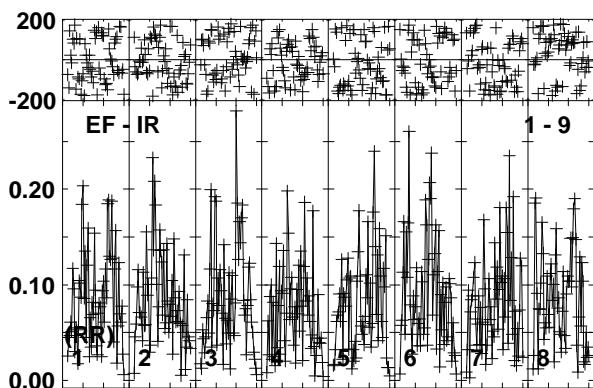
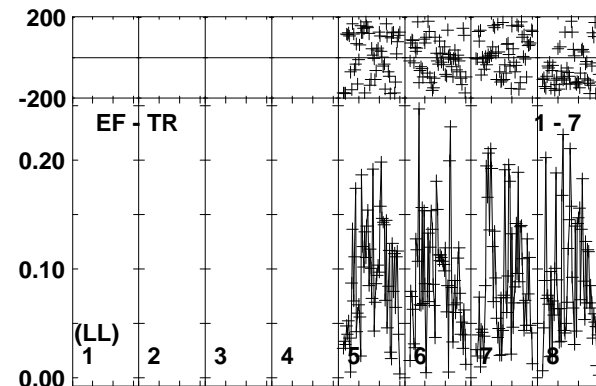
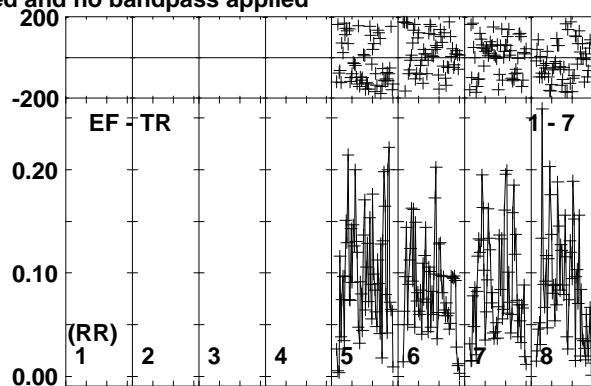
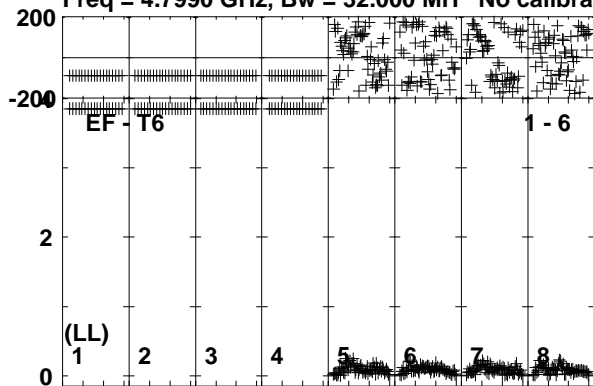

Lower frame: Milli Ampl Jy Top frame: Phas deg
Vector averaged cross-power spectrum Baseline: EF (01) - T6 (06)
Timerange: 00/08:32:49 to 00/08:36:18

Plot file version 121 created 03-OCT-2017 13:27:39

J1108+4330 EG096C.UVDATA.1

Freq = 4.7990 GHz, Bw = 32.000 MH No calibration applied and no bandpass applied

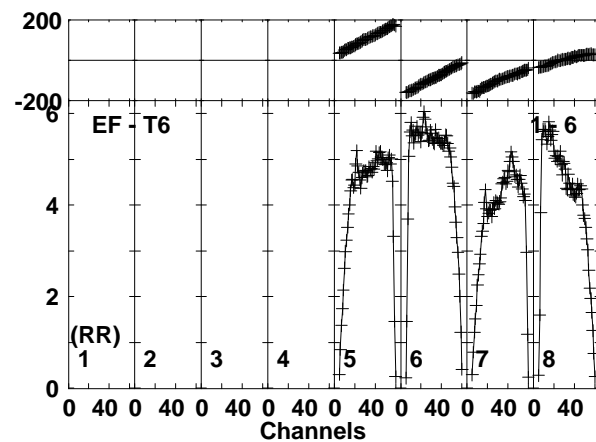
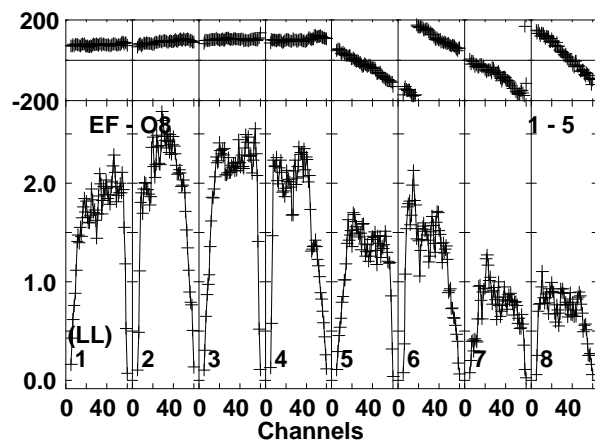
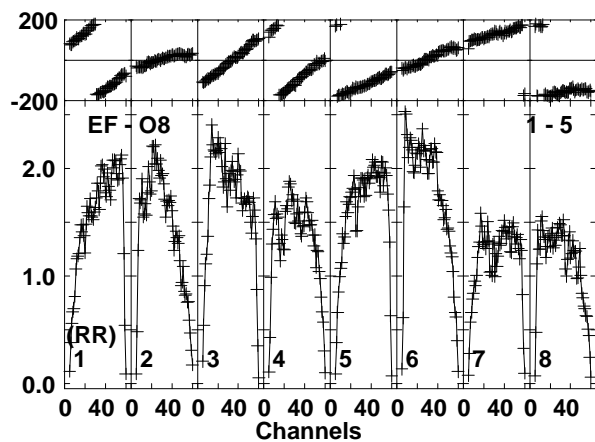
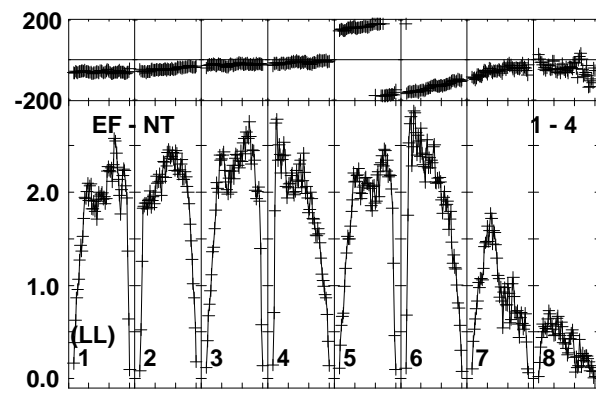
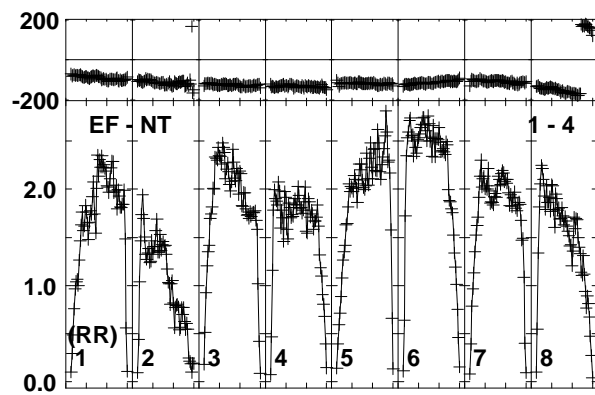
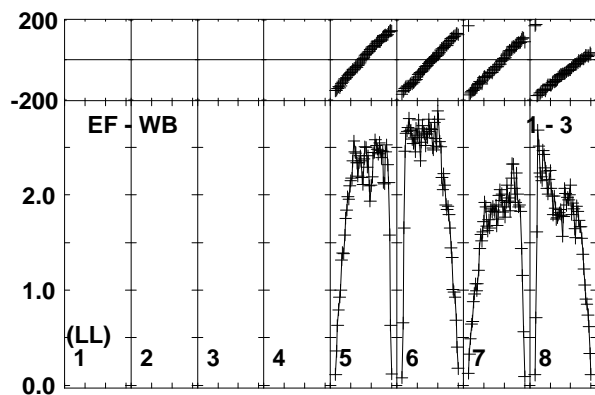
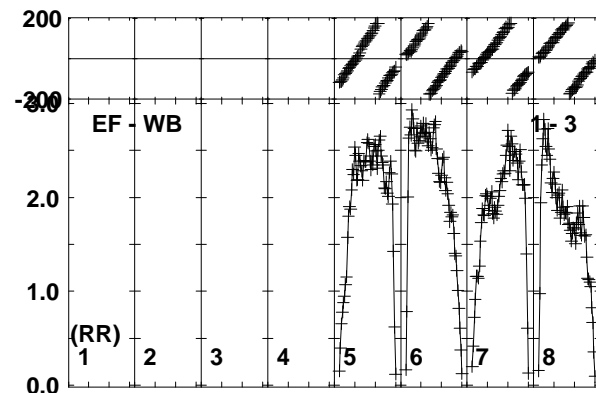
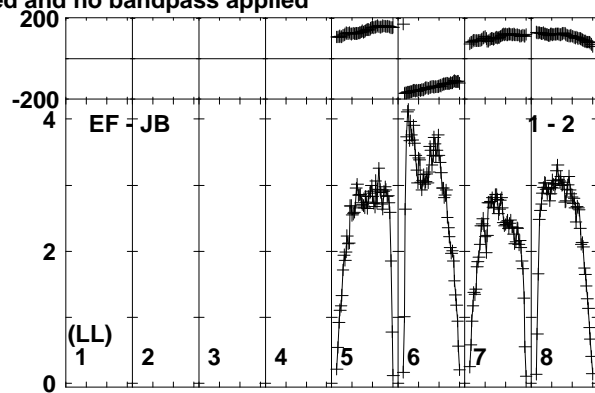
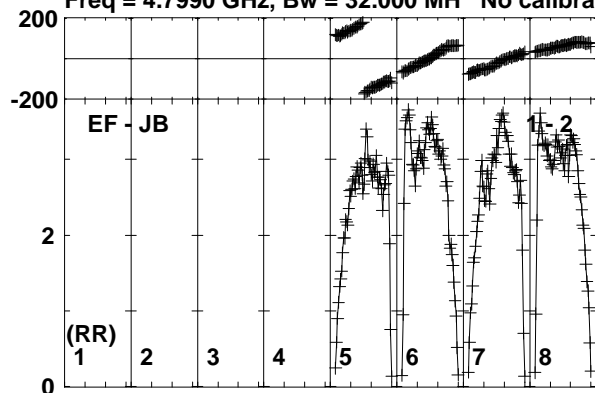

Lower frame: Milli Ampl Jy Top frame: Phas deg
Vector averaged cross-power spectrum Baseline: EF (01) - JB (02)
Timerange: 00/08:36:20 to 00/08:37:49

Plot file version 122 created 03-OCT-2017 13:27:39

J1108+4330 EG096C.UVDATA.1

Freq = 4.7990 GHz, Bw = 32.000 MH No calibration applied and no bandpass applied

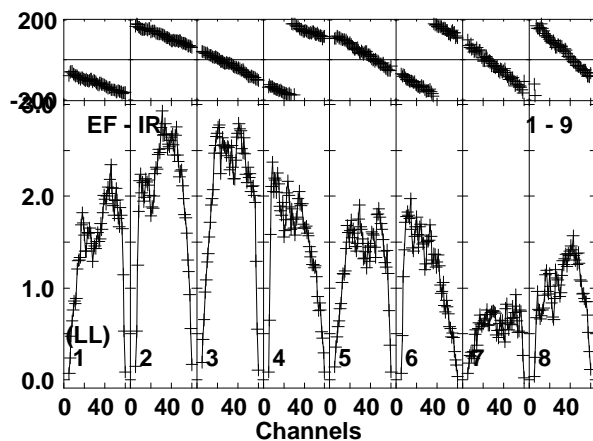
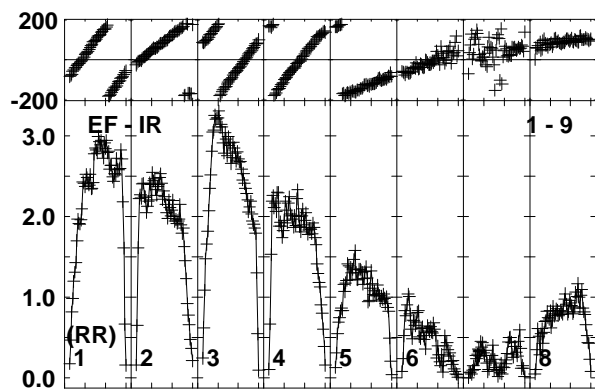
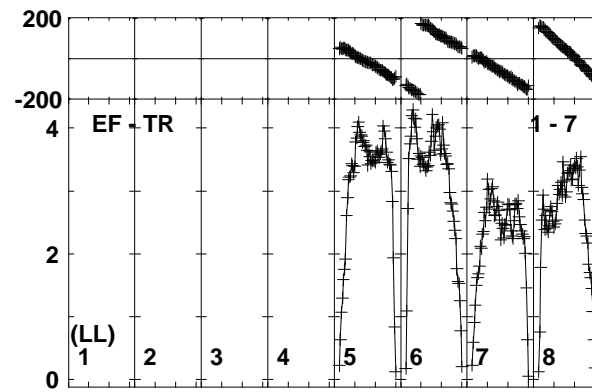
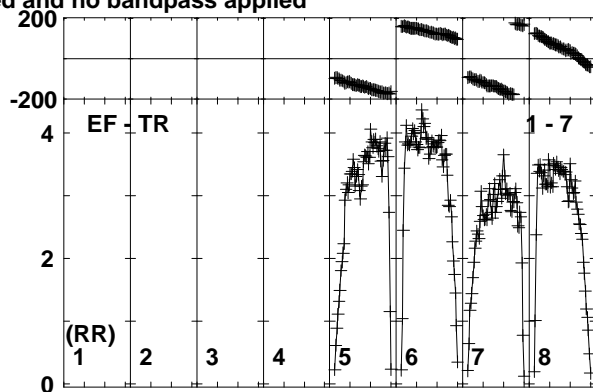
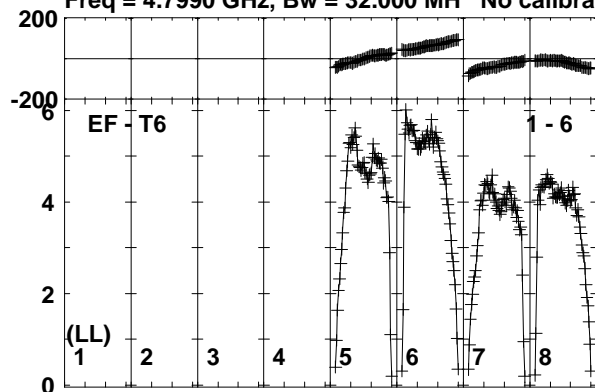

Lower frame: Milli Ampl Jy Top frame: Phas deg
Vector averaged cross-power spectrum Baseline: EF (01) - T6 (06)
Timerange: 00/08:36:20 to 00/08:37:49

Plot file version 123 created 03-OCT-2017 13:27:39

ARUMA EG096C.UVDATA.1

Freq = 4.7990 GHz, Bw = 32.000 MH No calibration applied and no bandpass applied

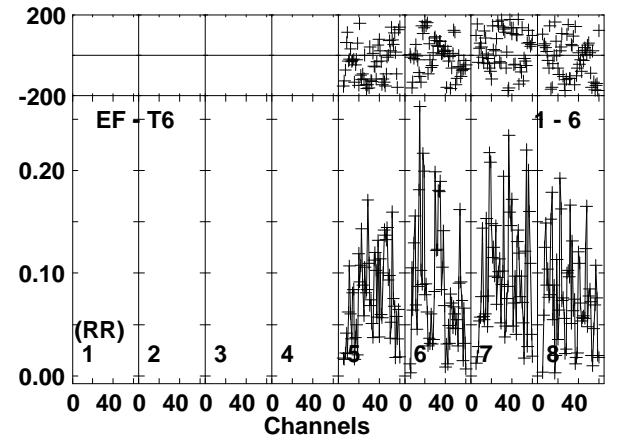
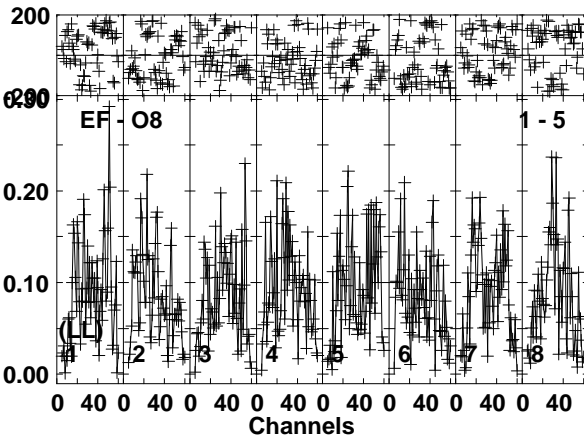
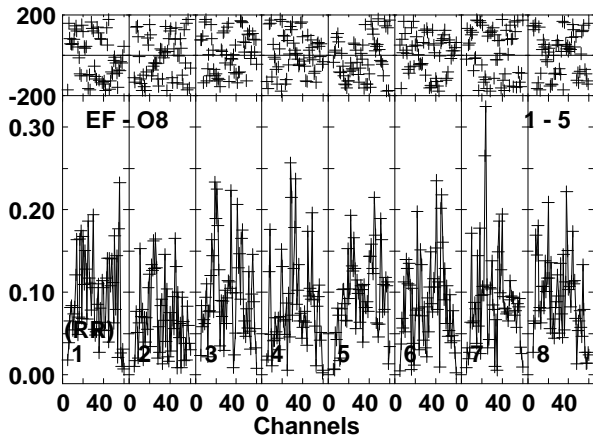
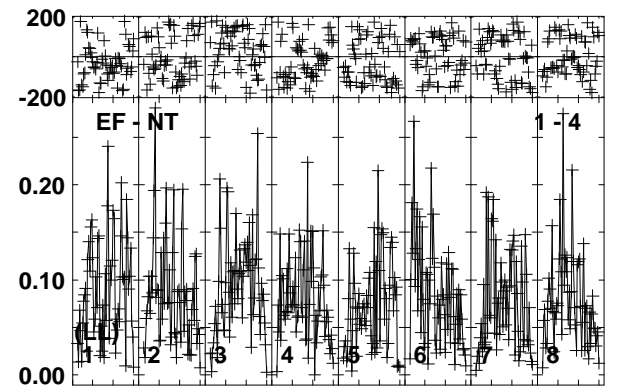
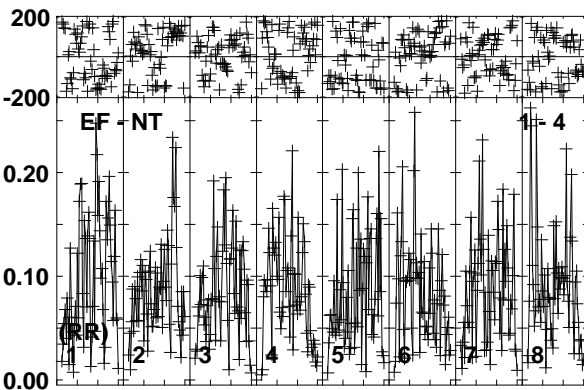
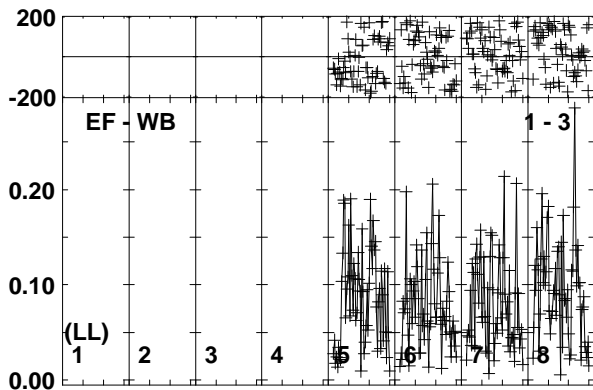
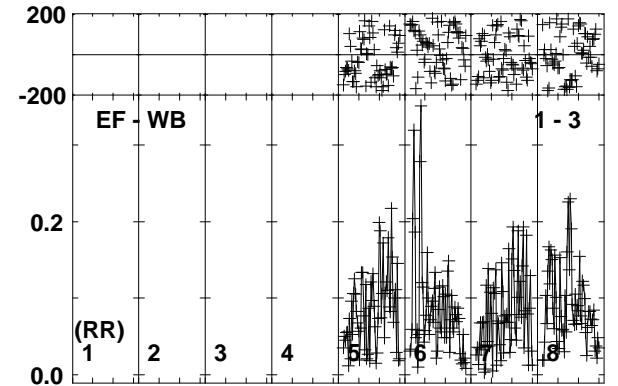
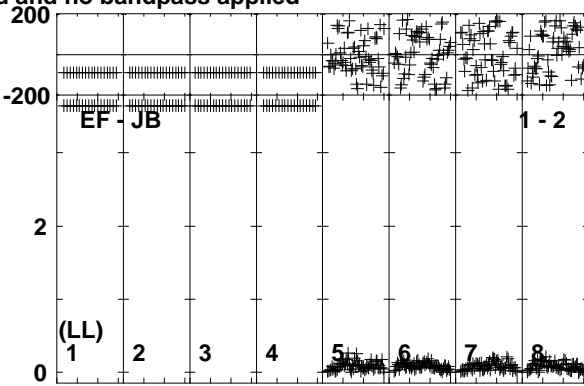
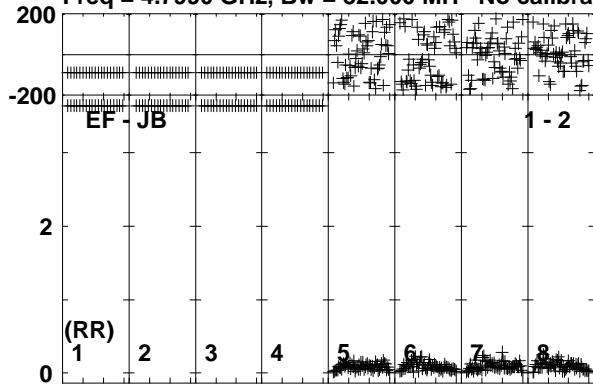

Lower frame: Milli Ampl Jy Top frame: Phas deg
Vector averaged cross-power spectrum Baseline: EF (01) - JB (02)
Timerange: 00/08:37:50 to 00/08:41:19

Plot file version 124 created 03-OCT-2017 13:27:40
 ARUMA EG096C.UVDATA.1
 Freq = 4.7990 GHz, Bw = 32.000 MH No calibration applied and no bandpass applied

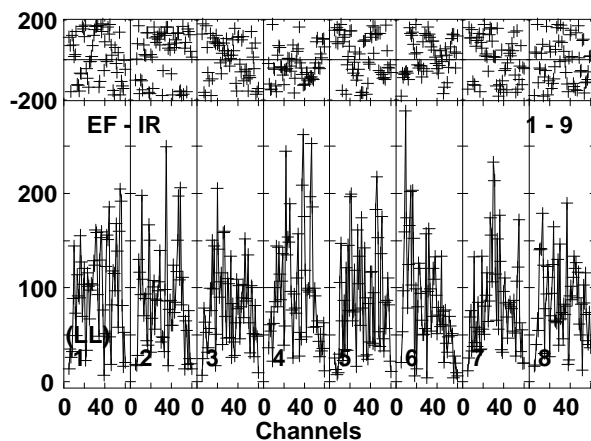
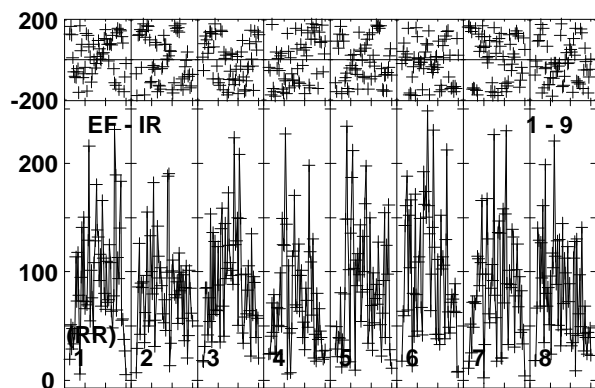
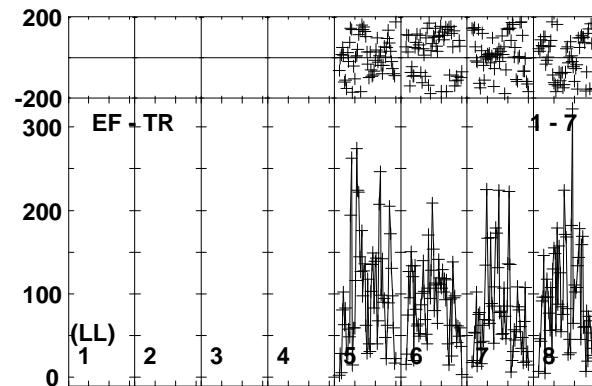
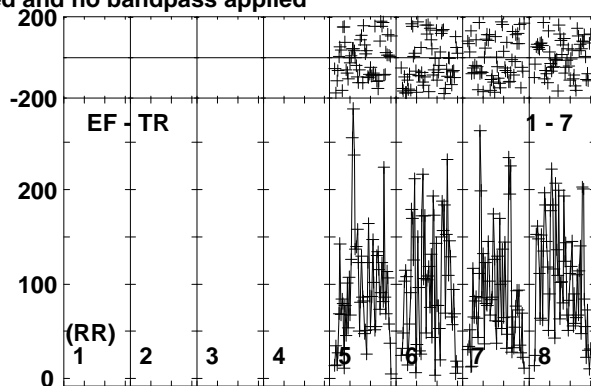
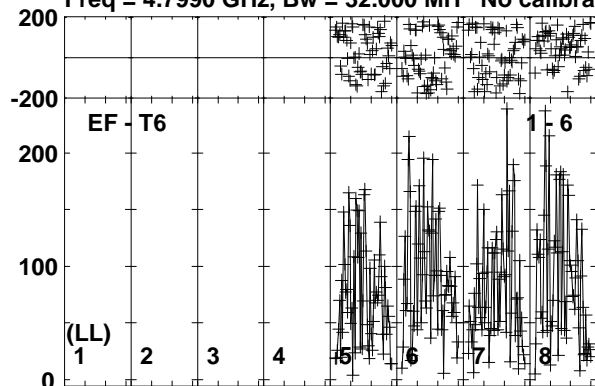

Lower frame: Micro Ampl Jy Top frame: Phas deg
 Vector averaged cross-power spectrum Baseline: EF (01) - T6 (06)
 Timerange: 00/08:37:50 to 00/08:41:19

Plot file version 125 created 03-OCT-2017 13:27:40

J1108+4330 EG096C.UVDATA.1

Freq = 4.7990 GHz, Bw = 32.000 MH No calibration applied and no bandpass applied

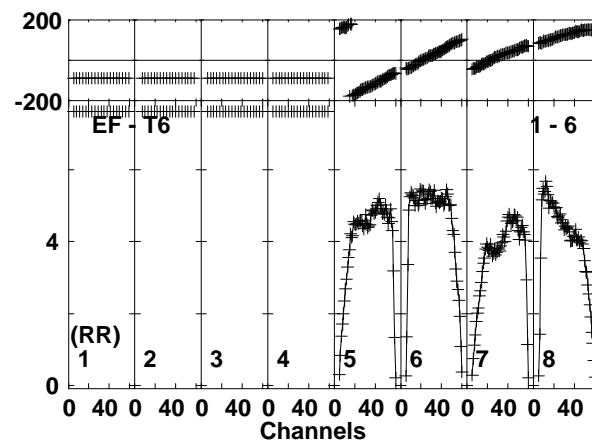
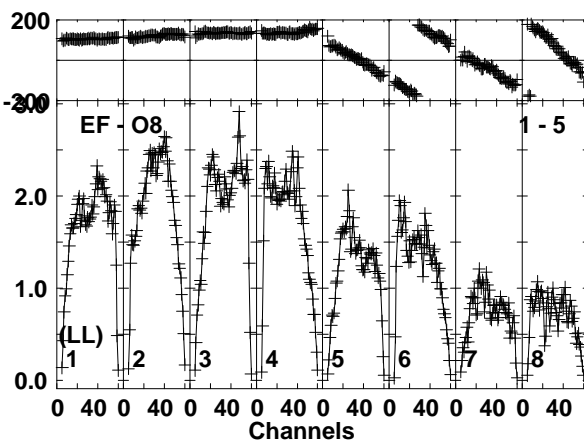
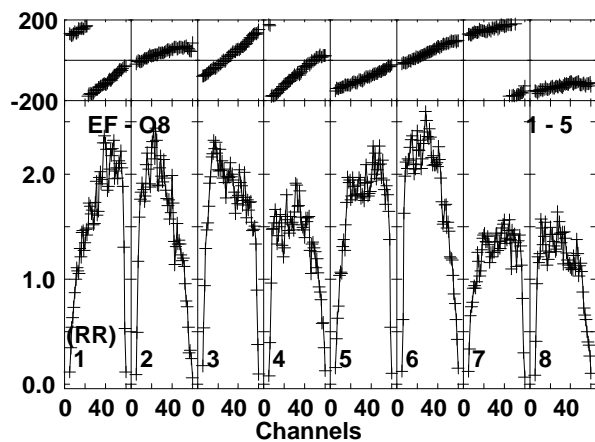
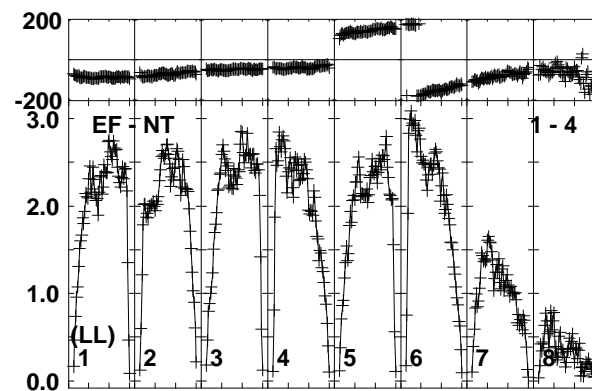
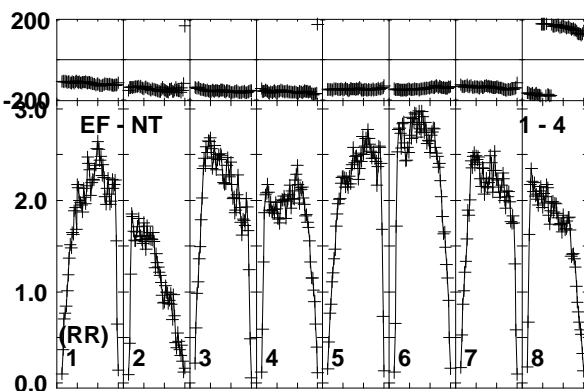
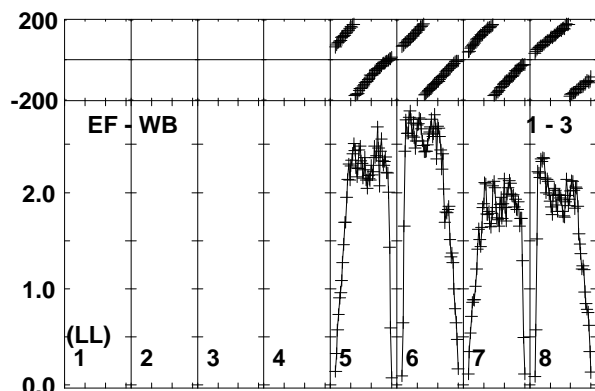
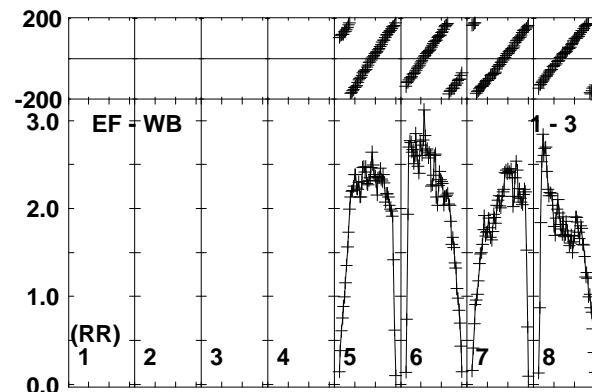
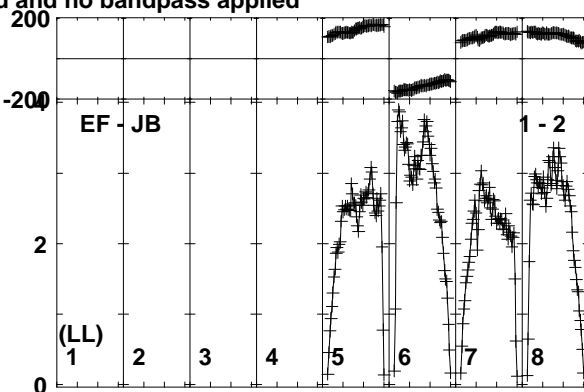
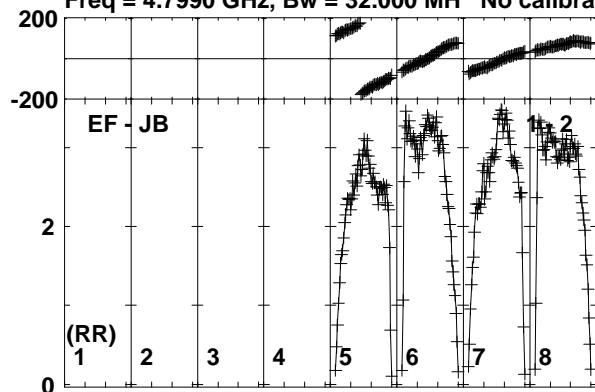

Lower frame: Milli Ampl Jy Top frame: Phas deg
Vector averaged cross-power spectrum Baseline: EF (01) - JB (02)
Timerange: 00/08:41:59 to 00/08:42:59

Plot file version 126 created 03-OCT-2017 13:27:40

J1108+4330 EG096C.UVDATA.1

Freq = 4.7990 GHz, Bw = 32.000 MH No calibration applied and no bandpass applied

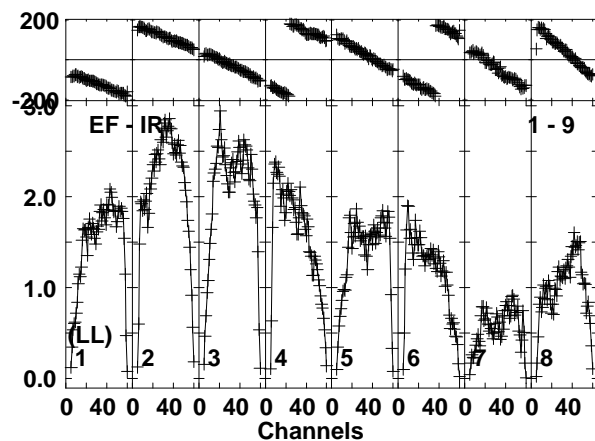
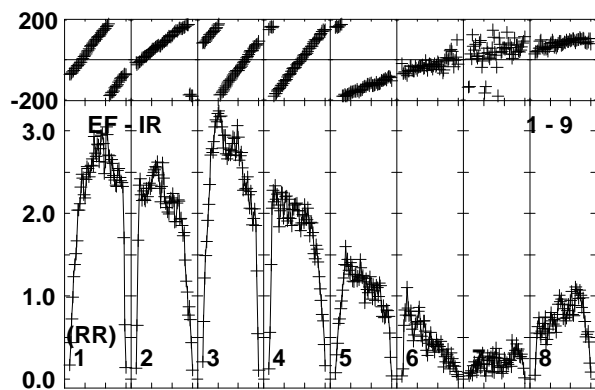
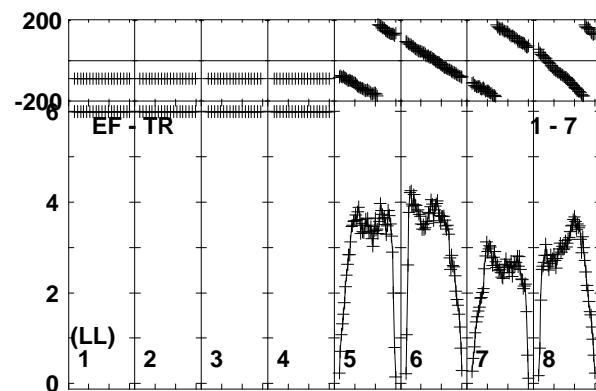
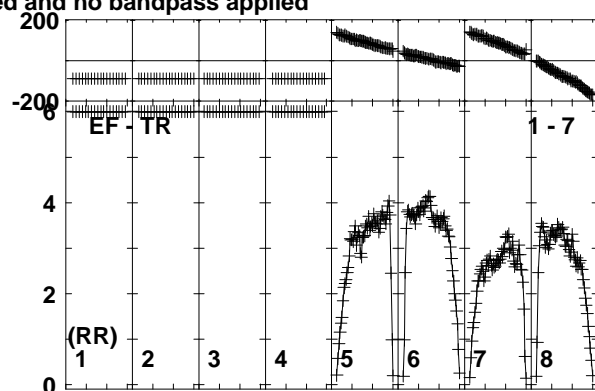
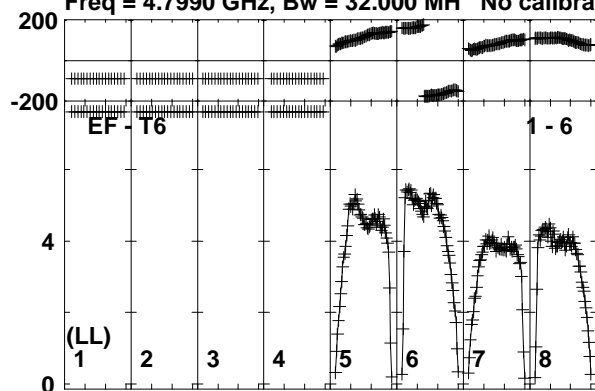

Lower frame: Milli Ampl Jy Top frame: Phas deg
Vector averaged cross-power spectrum Baseline: EF (01) - T6 (06)
Timerange: 00/08:41:59 to 00/08:42:59

Plot file version 127 created 03-OCT-2017 13:27:40

J1112+4301 EG096C.UVDATA.1

Freq = 4.7990 GHz, Bw = 32.000 MH No calibration applied and no bandpass applied

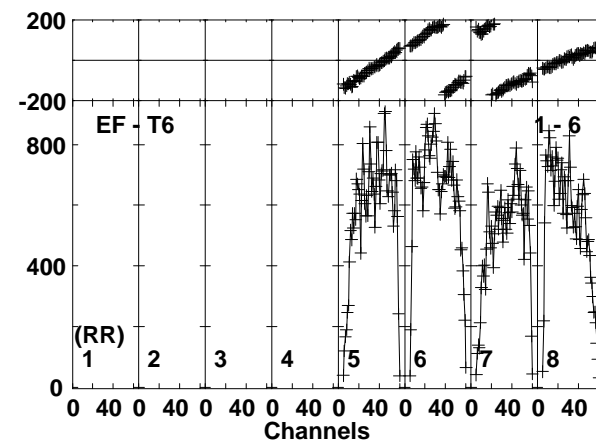
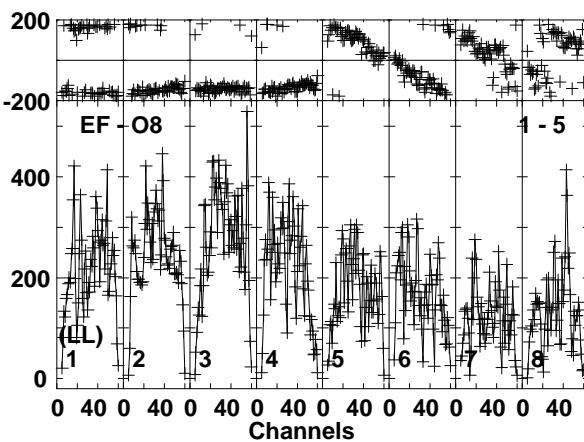
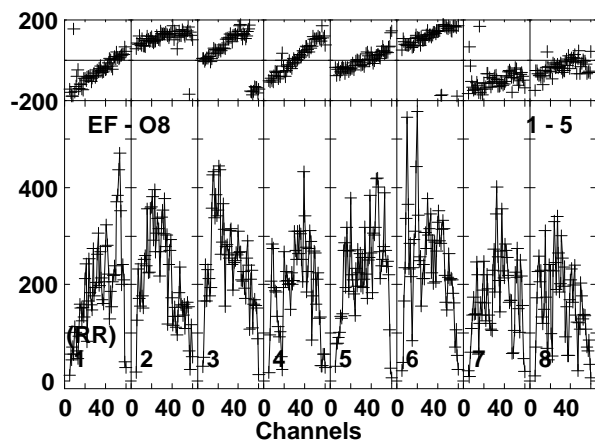
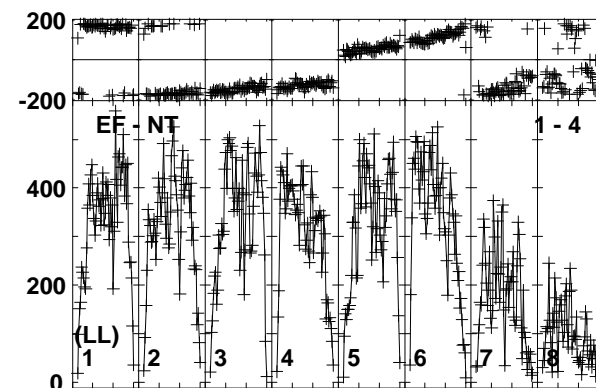
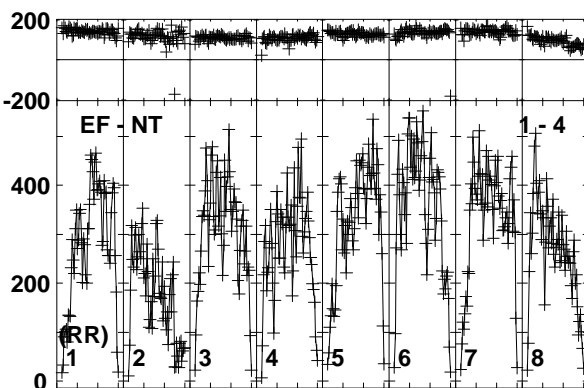
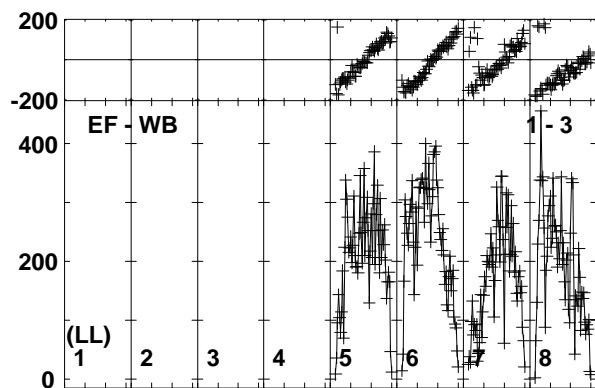
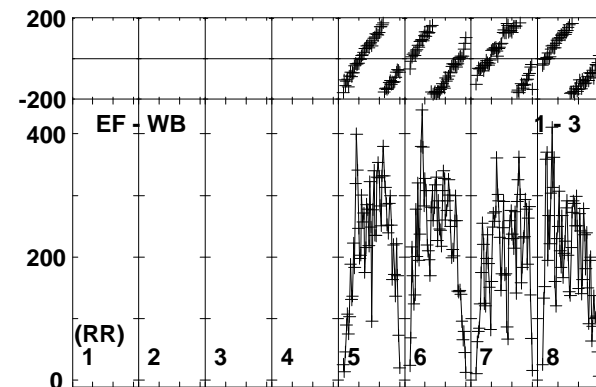
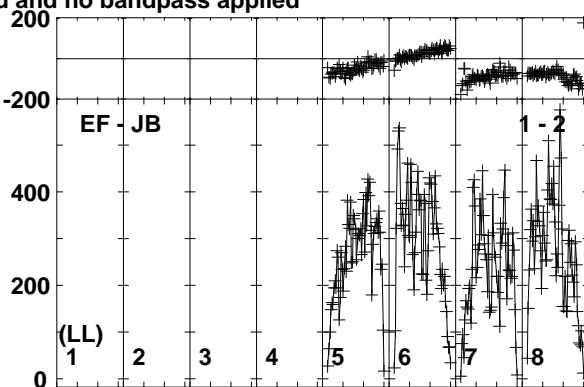
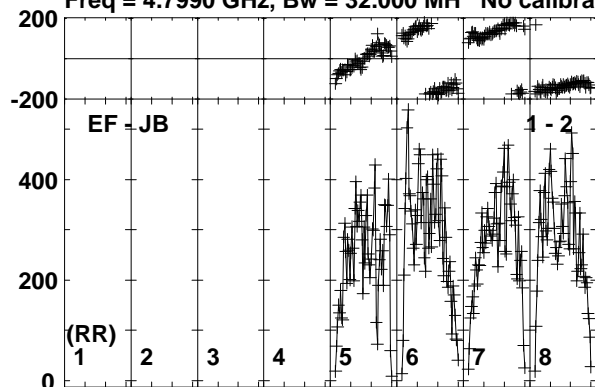

Lower frame: Micro Ampl Jy Top frame: Phas deg
Vector averaged cross-power spectrum Baseline: EF (01) - JB (02)
Timerange: 00/08:43:00 to 00/08:46:29

Plot file version 128 created 03-OCT-2017 13:27:40

J1112+4301 EG096C.UVDATA.1

Freq = 4.7990 GHz, Bw = 32.000 MH No calibration applied and no bandpass applied

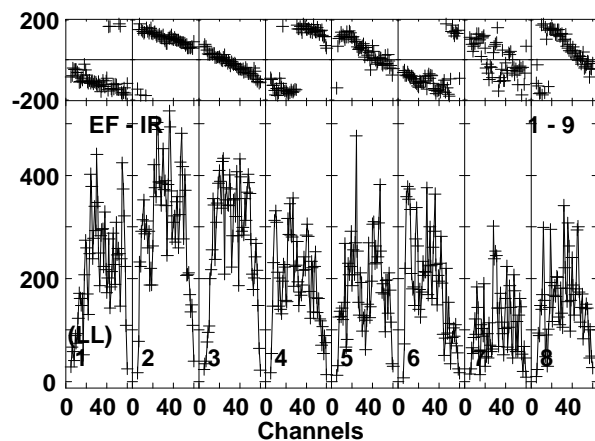
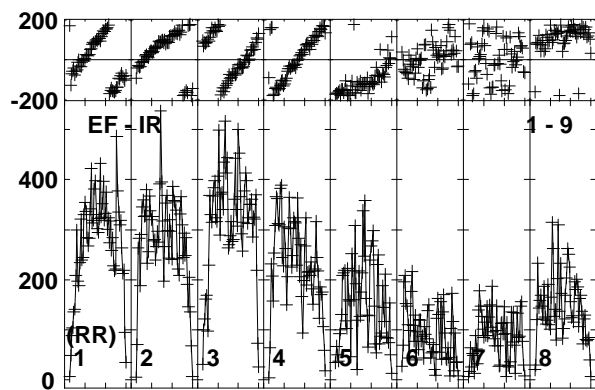
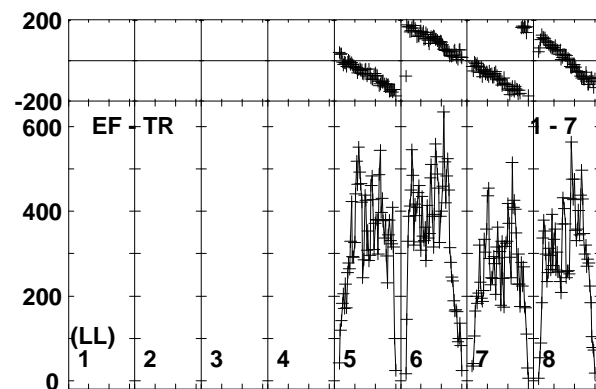
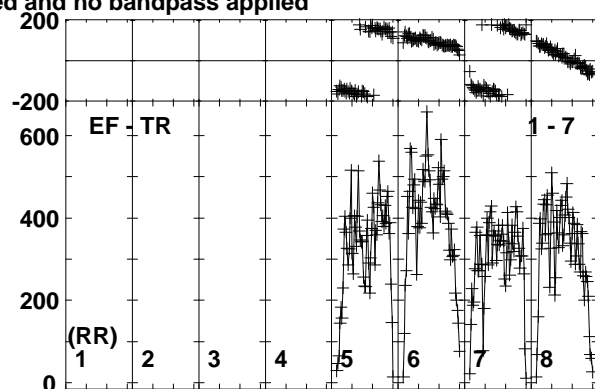
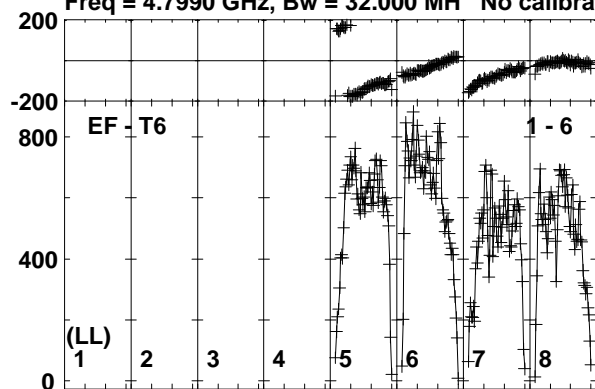

Lower frame: Micro Ampl Jy Top frame: Phas deg
Vector averaged cross-power spectrum Baseline: EF (01) - T6 (06)
Timerange: 00/08:43:00 to 00/08:46:29

Plot file version 129 created 03-OCT-2017 13:27:41

J1108+4330 EG096C.UVDATA.1

Freq = 4.7990 GHz, Bw = 32.000 MH No calibration applied and no bandpass applied

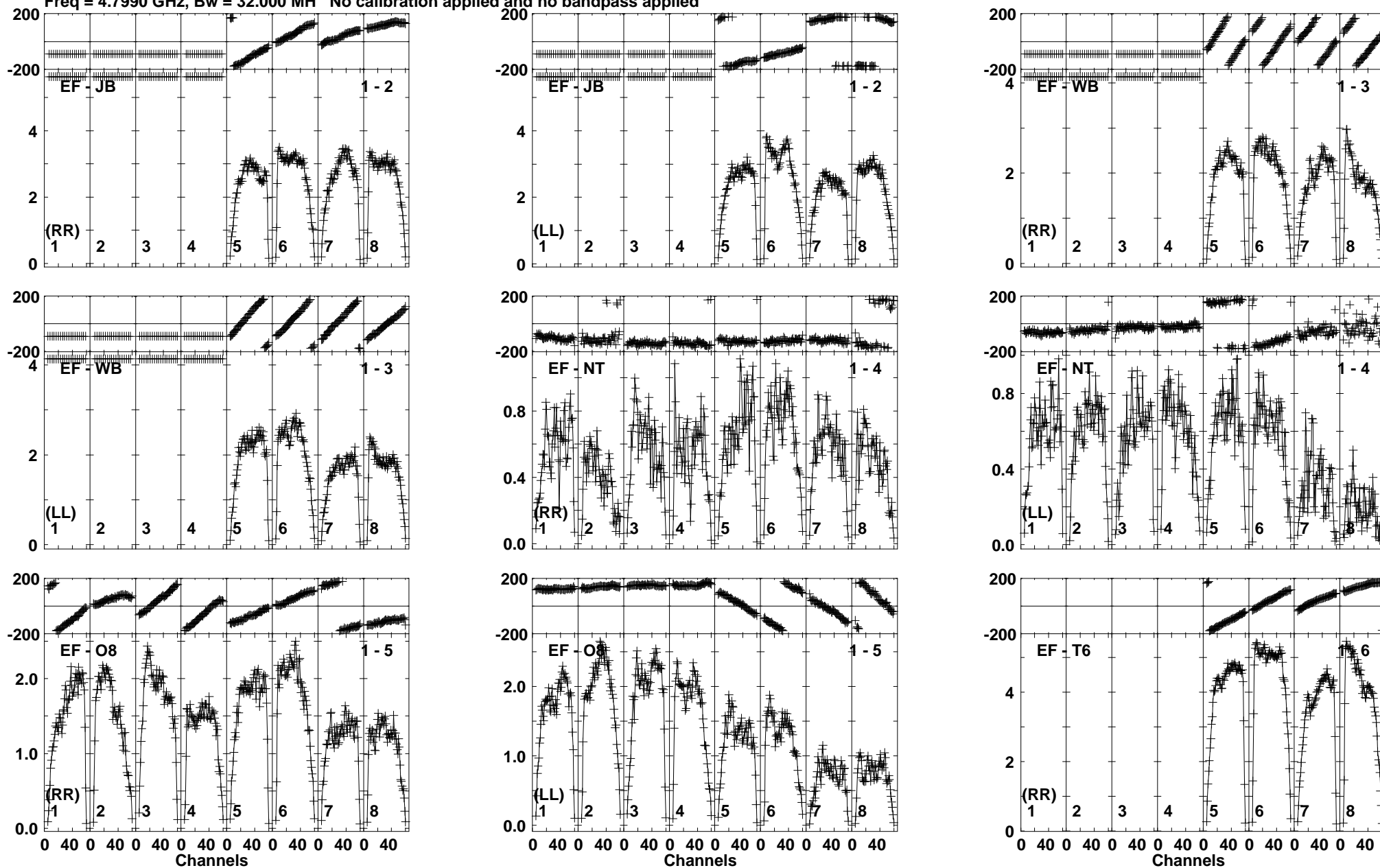

Lower frame: Milli Ampl Jy Top frame: Phas deg
Vector averaged cross-power spectrum Baseline: EF (01) - JB (02)
Timerange: 00/08:46:30 to 00/08:47:59

Plot file version 130 created 03-OCT-2017 13:27:41

J1108+4330 EG096C.UVDATA.1

Freq = 4.7990 GHz, Bw = 32.000 MH No calibration applied and no bandpass applied

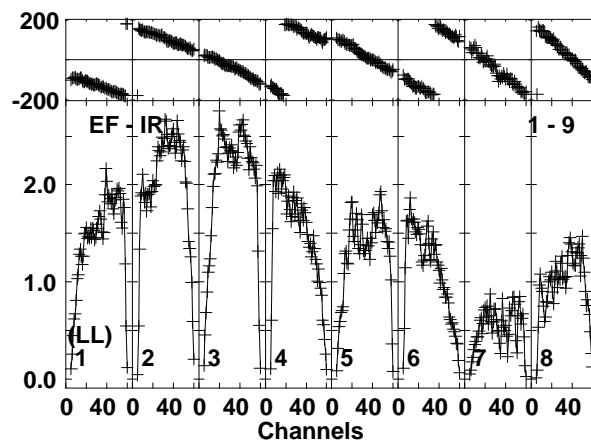
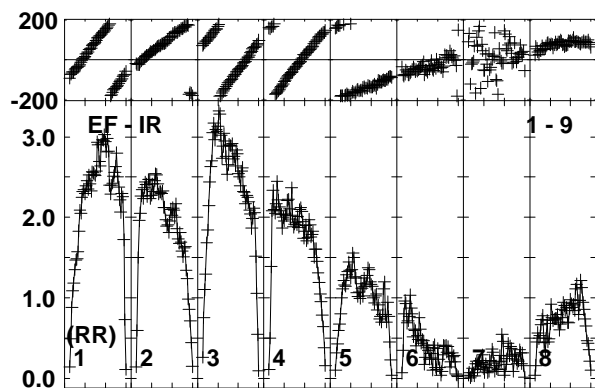
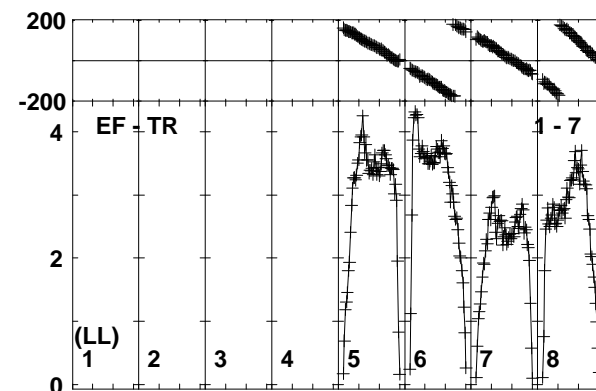
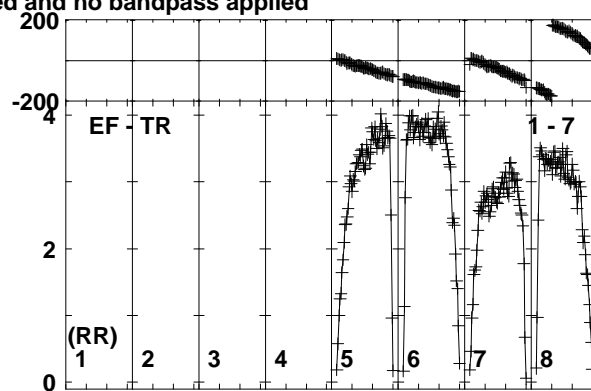
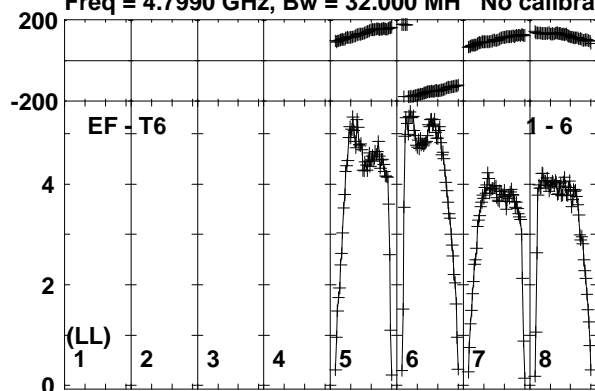

Lower frame: Milli Ampl Jy Top frame: Phas deg
Vector averaged cross-power spectrum Baseline: EF (01) - T6 (06)
Timerange: 00/08:46:30 to 00/08:47:59

Plot file version 131 created 03-OCT-2017 13:27:41
 ARUMA EG096C.UVDATA.1
 Freq = 4.7990 GHz, Bw = 32.000 MH No calibration applied and no bandpass applied

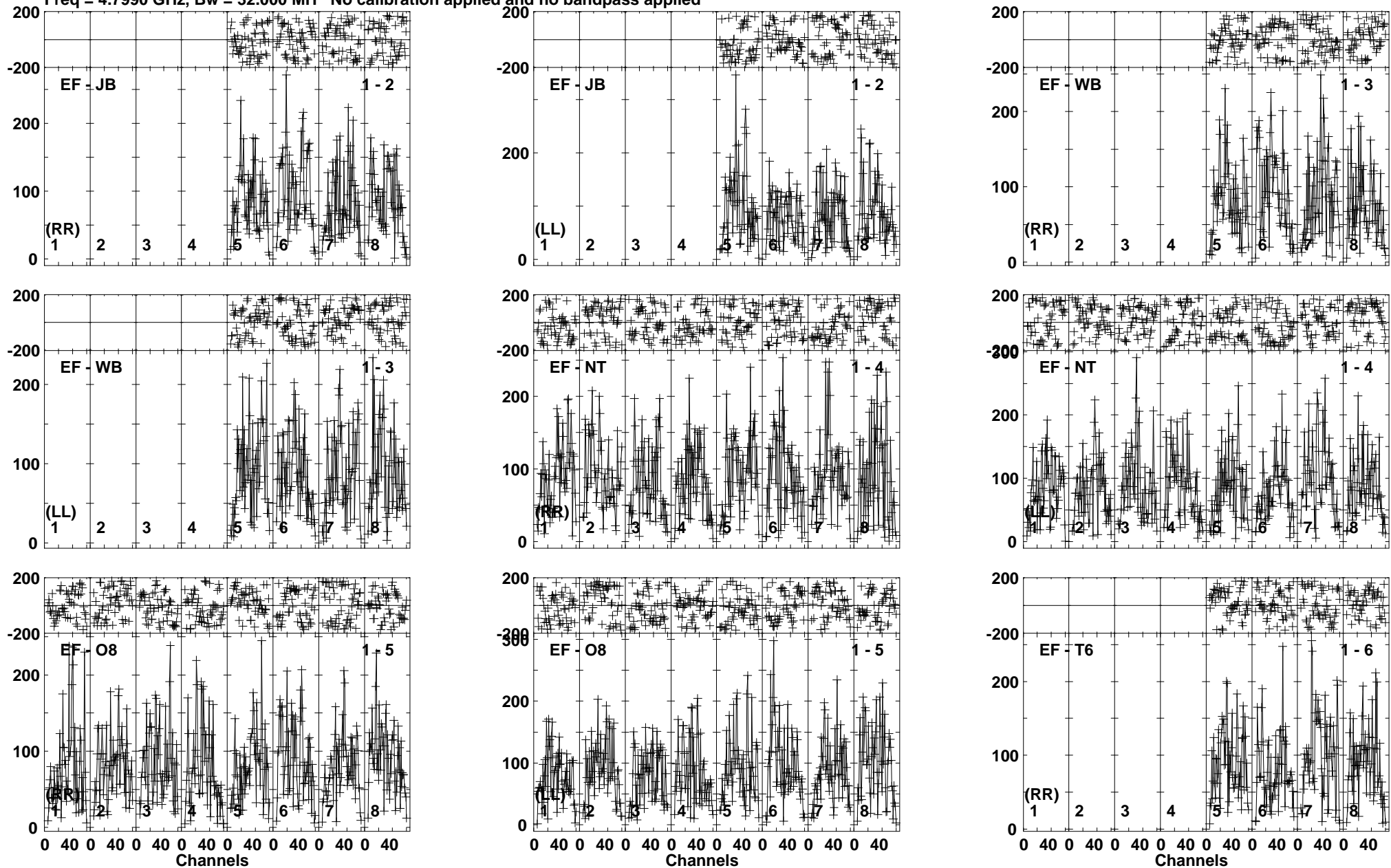

Lower frame: Micro Ampl Jy Top frame: Phas deg
 Vector averaged cross-power spectrum Baseline: EF (01) - JB (02)
 Timerange: 00/08:48:00 to 00/08:51:29

Plot file version 132 created 03-OCT-2017 13:27:41

ARUMA EG096C.UVDATA.1

Freq = 4.7990 GHz, Bw = 32.000 MH No calibration applied and no bandpass applied

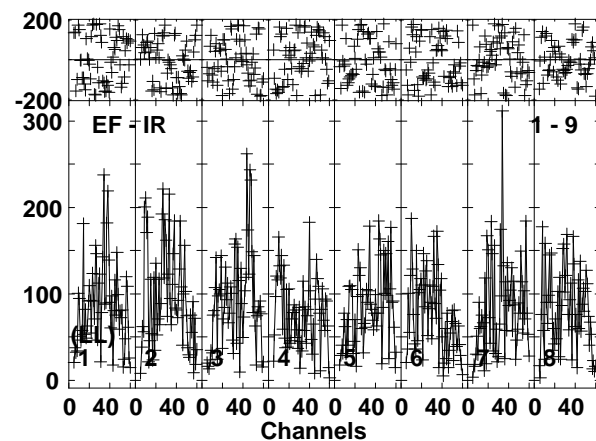
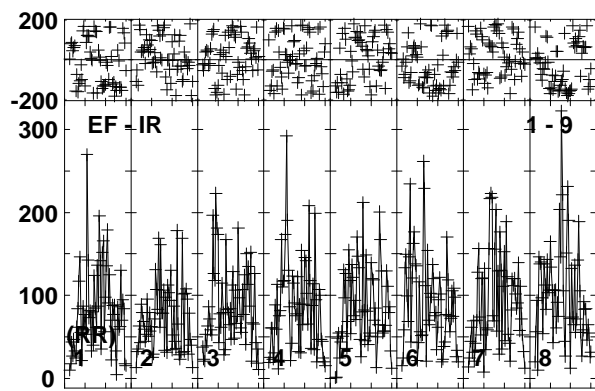
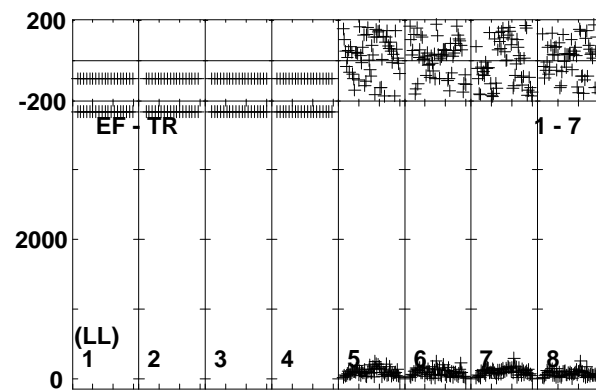
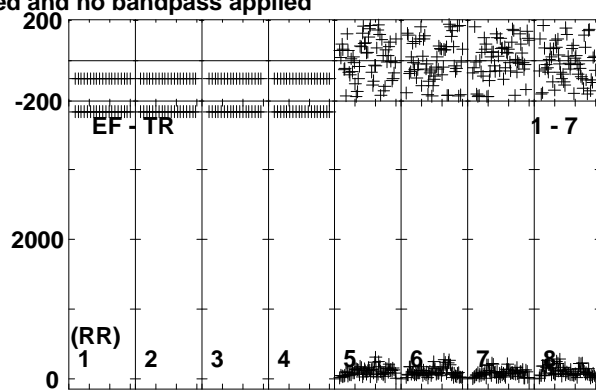
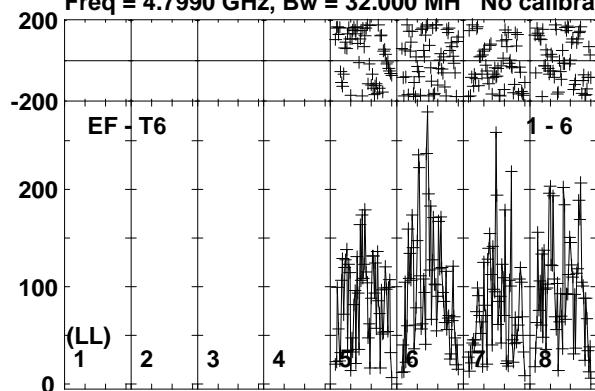

Lower frame: Micro Ampl Jy Top frame: Phas deg
Vector averaged cross-power spectrum Baseline: EF (01) - T6 (06)
Timerange: 00/08:48:00 to 00/08:51:29

Plot file version 133 created 03-OCT-2017 13:27:42

J1108+4330 EG096C.UVDATA.1

Freq = 4.7990 GHz, Bw = 32.000 MH No calibration applied and no bandpass applied

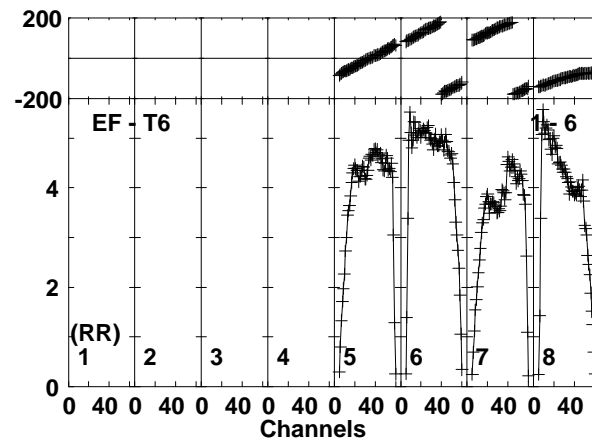
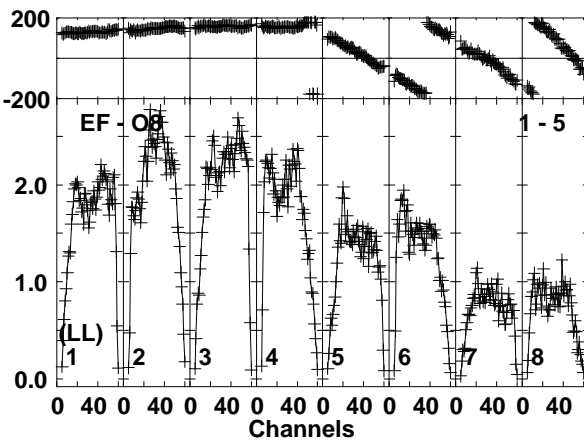
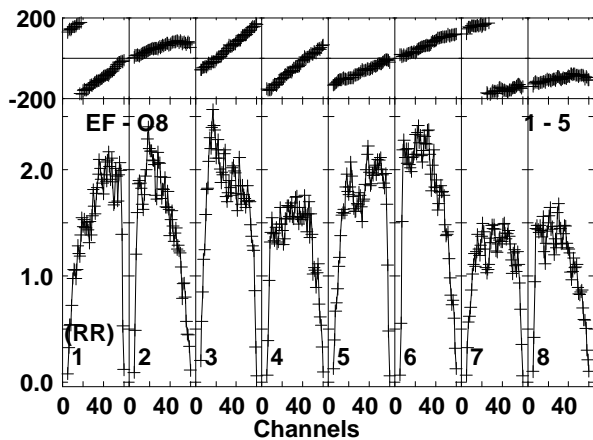
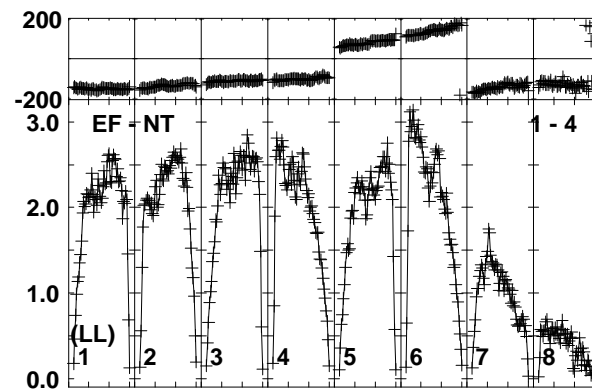
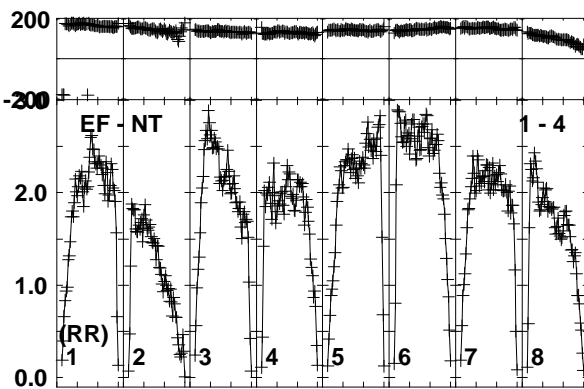
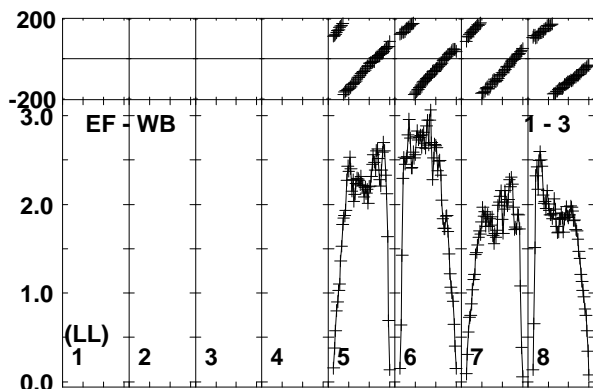
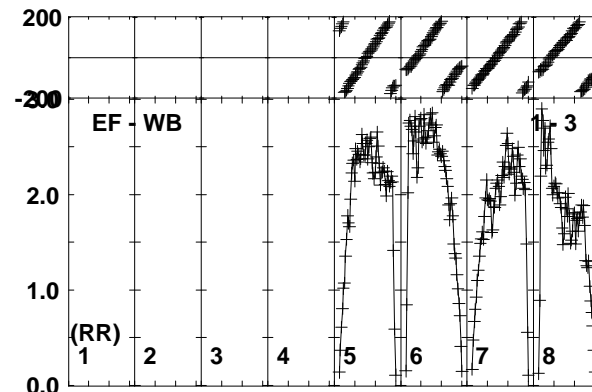
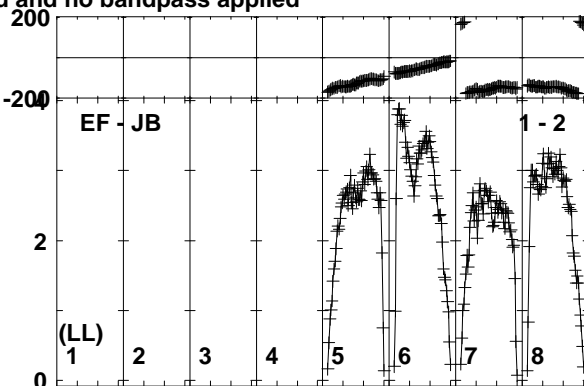
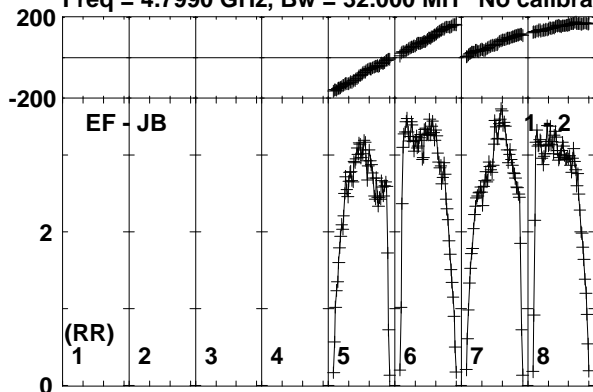

Lower frame: Milli Ampl Jy Top frame: Phas deg
Vector averaged cross-power spectrum Baseline: EF (01) - JB (02)
Timerange: 00/08:52:10 to 00/08:53:08

Plot file version 134 created 03-OCT-2017 13:27:42

J1108+4330 EG096C.UVDATA.1

Freq = 4.7990 GHz, Bw = 32.000 MH No calibration applied and no bandpass applied

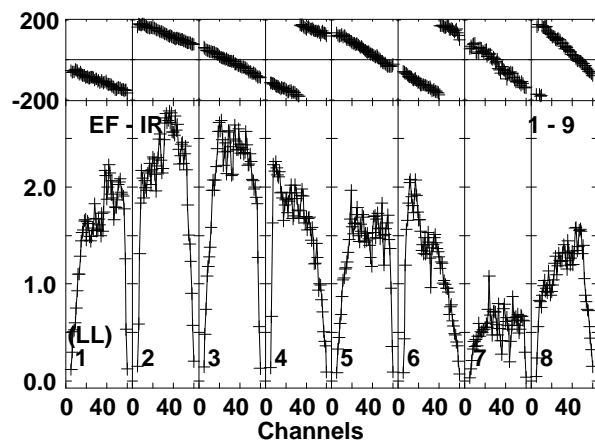
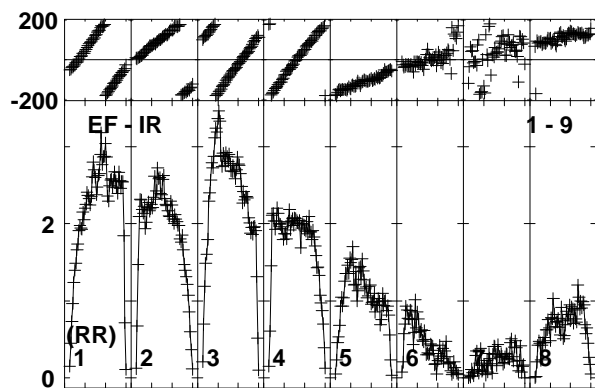
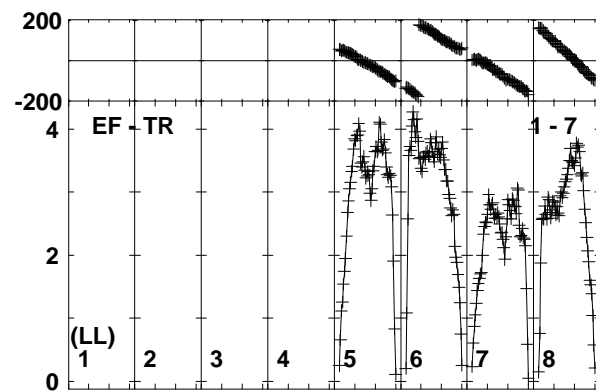
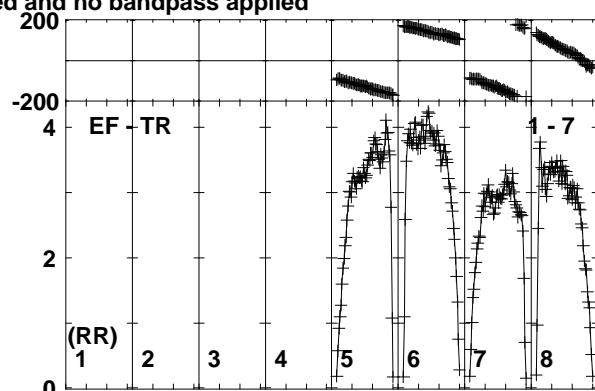
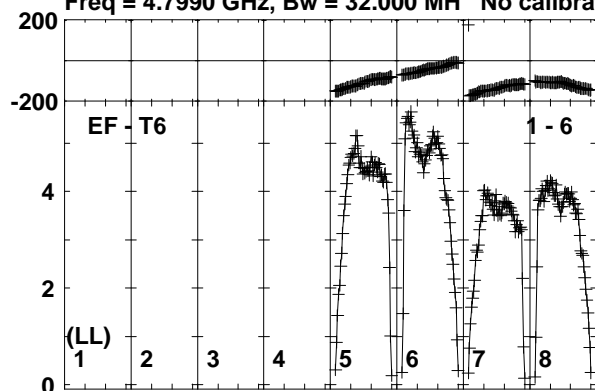

Lower frame: Milli Ampl Jy Top frame: Phas deg
Vector averaged cross-power spectrum Baseline: EF (01) - T6 (06)
Timerange: 00/08:52:10 to 00/08:53:08

Plot file version 135 created 03-OCT-2017 13:27:42

ARUMA EG096C.UVDATA.1

Freq = 4.7990 GHz, Bw = 32.000 MH No calibration applied and no bandpass applied

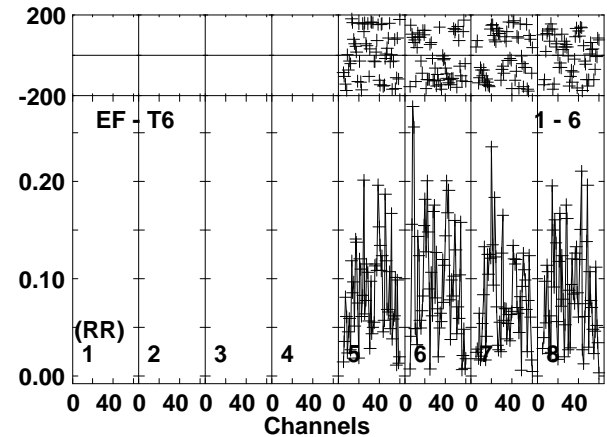
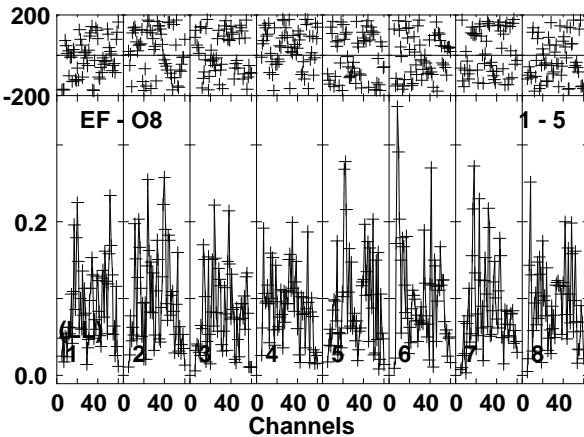
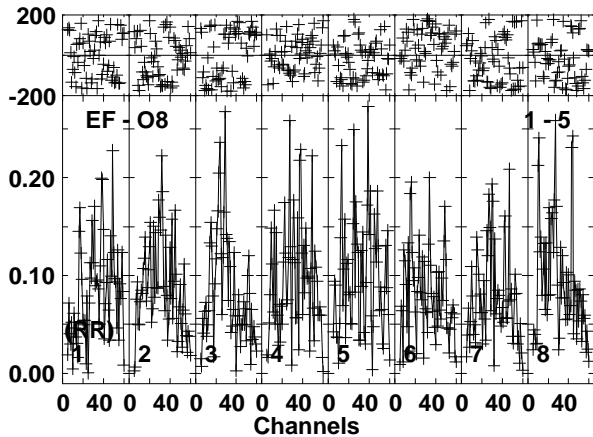
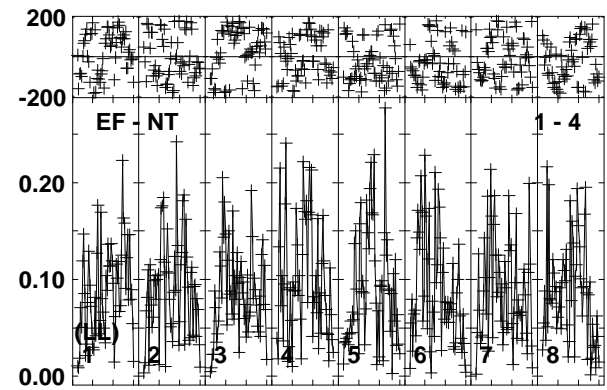
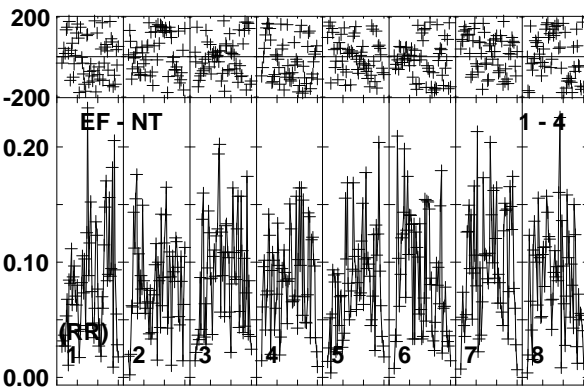
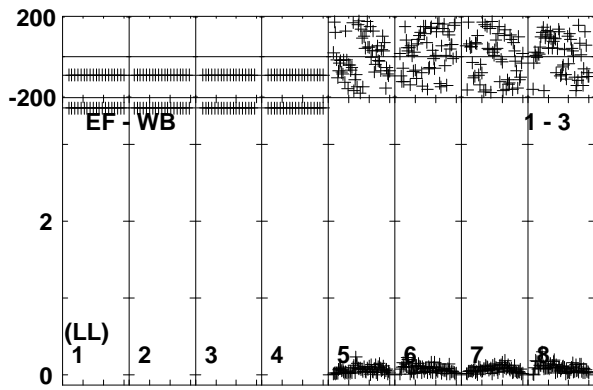
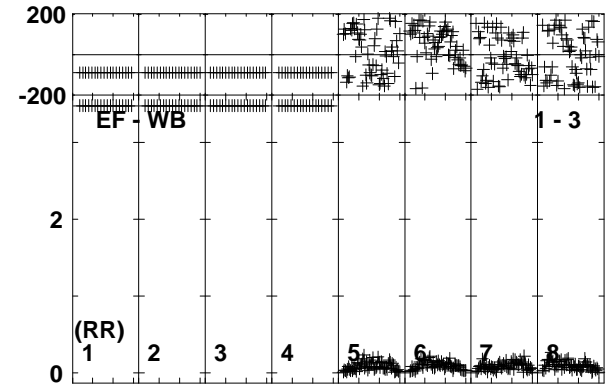
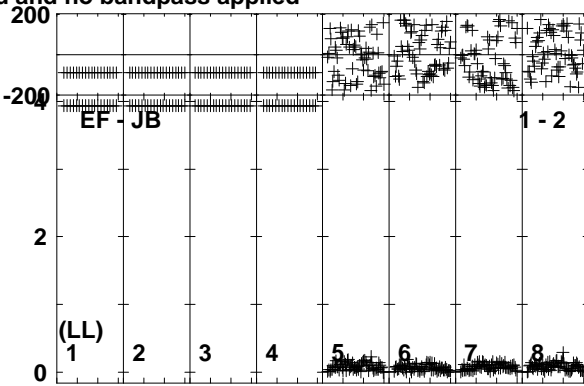
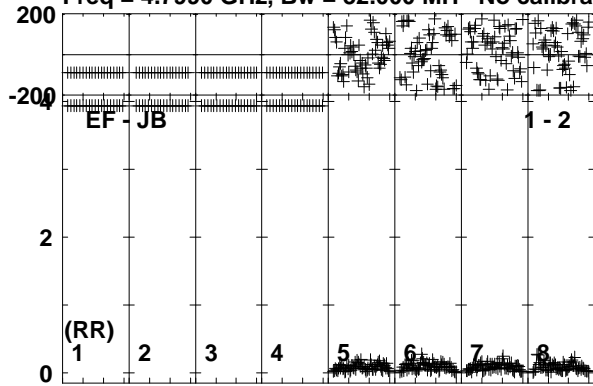

Lower frame: Milli Ampl Jy Top frame: Phas deg
Vector averaged cross-power spectrum Baseline: EF (01) - JB (02)
Timerange: 00/08:53:10 to 00/08:56:39

Plot file version 136 created 03-OCT-2017 13:27:42

ARUMA EG096C.UVDATA.1

Freq = 4.7990 GHz, Bw = 32.000 MH No calibration applied and no bandpass applied

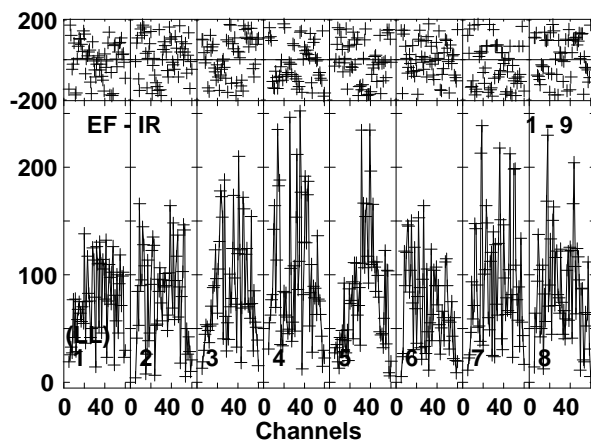
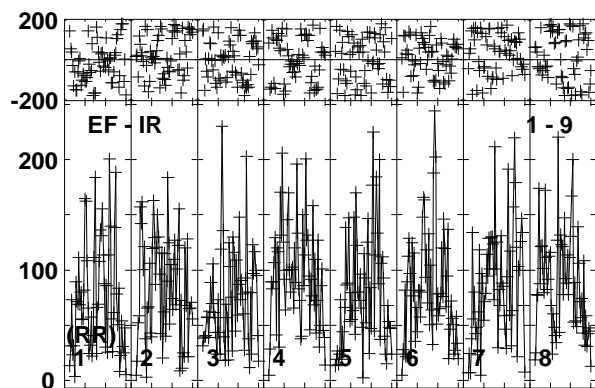
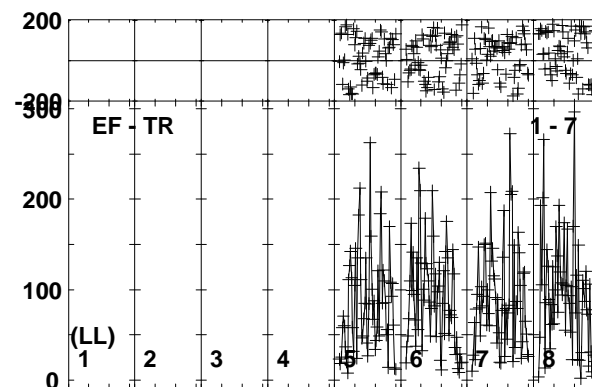
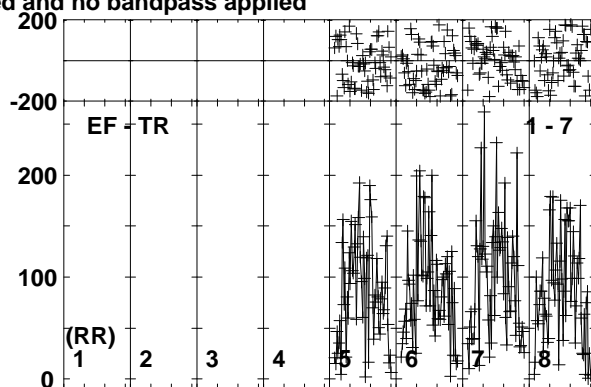
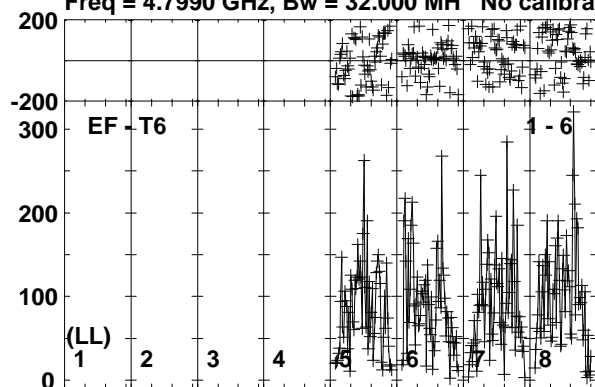

Lower frame: Micro Ampl Jy Top frame: Phas deg
Vector averaged cross-power spectrum Baseline: EF (01) - T6 (06)
Timerange: 00/08:53:10 to 00/08:56:39

Plot file version 137 created 03-OCT-2017 13:27:43

J1108+4330 EG096C.UVDATA.1

Freq = 4.7990 GHz, Bw = 32.000 MH No calibration applied and no bandpass applied

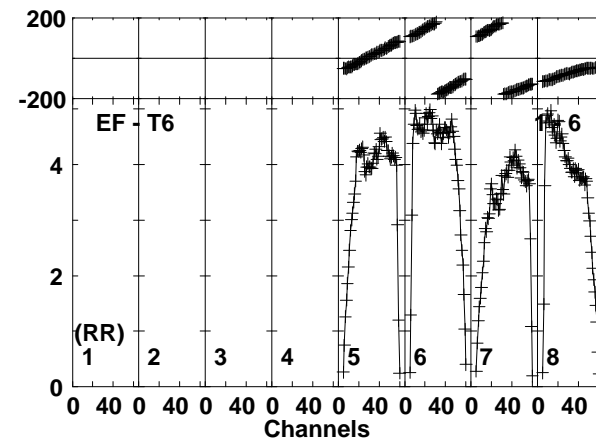
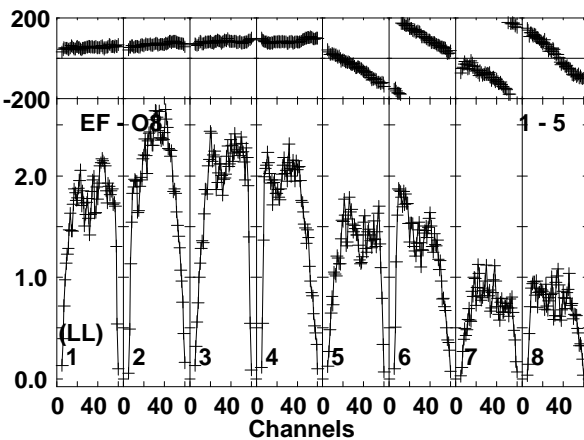
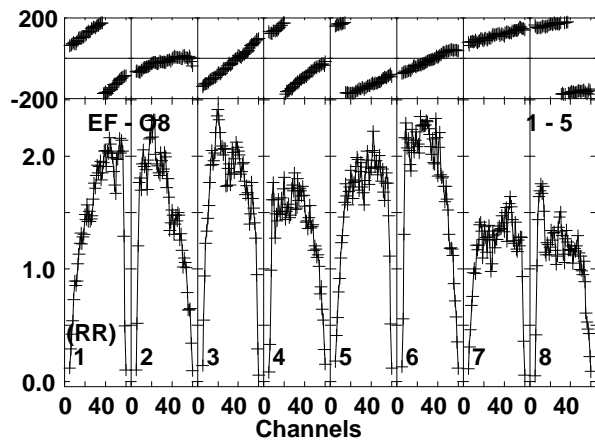
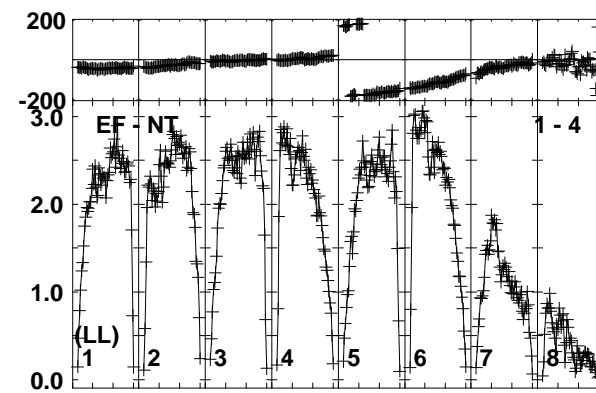
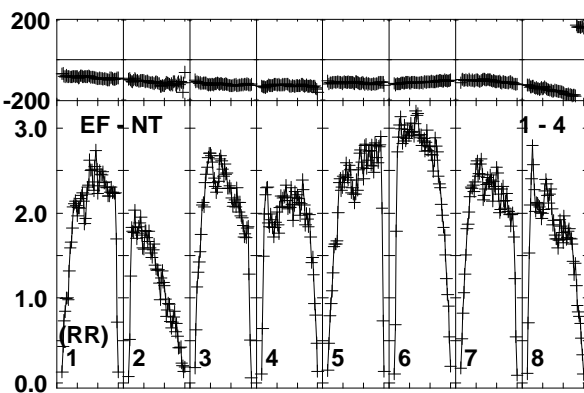
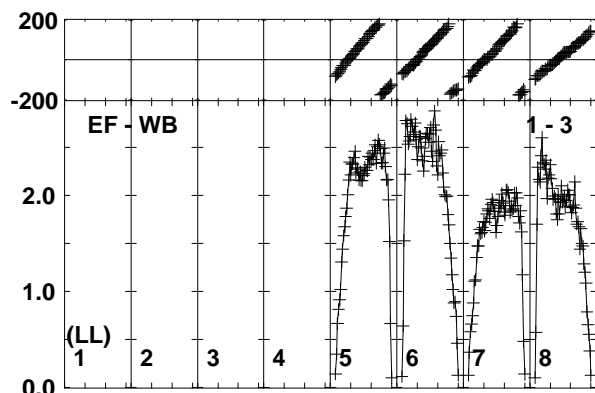
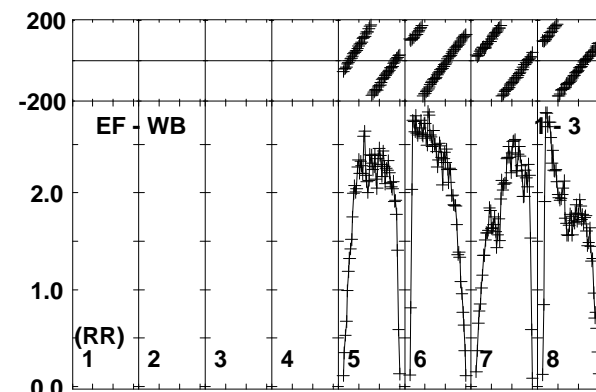
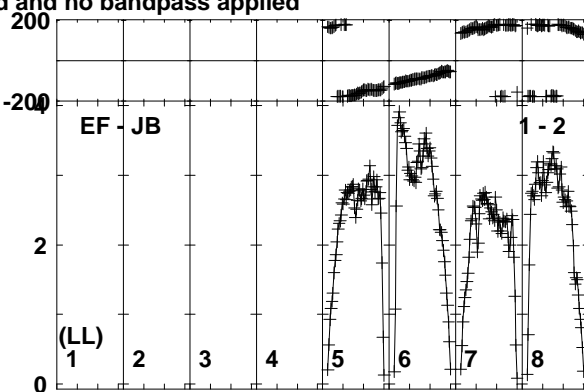
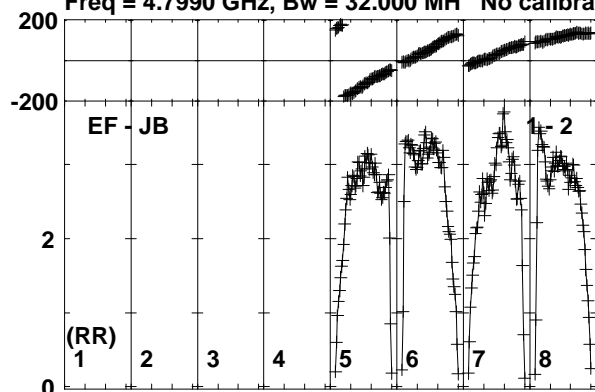

Lower frame: Milli Ampl Jy Top frame: Phas deg
Vector averaged cross-power spectrum Baseline: EF (01) - JB (02)
Timerange: 00/08:56:39 to 00/08:58:09

Plot file version 138 created 03-OCT-2017 13:27:43

J1108+4330 EG096C.UVDATA.1

Freq = 4.7990 GHz, Bw = 32.000 MH No calibration applied and no bandpass applied

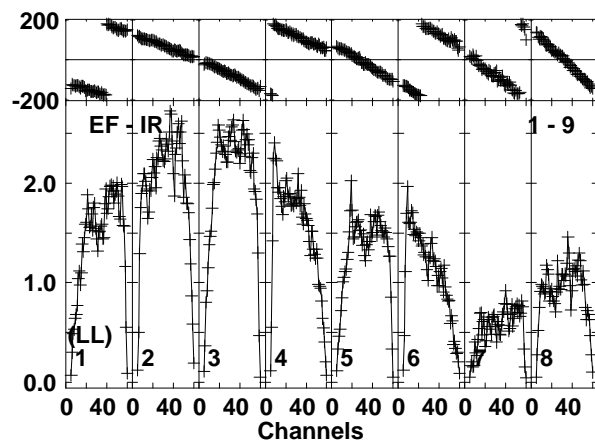
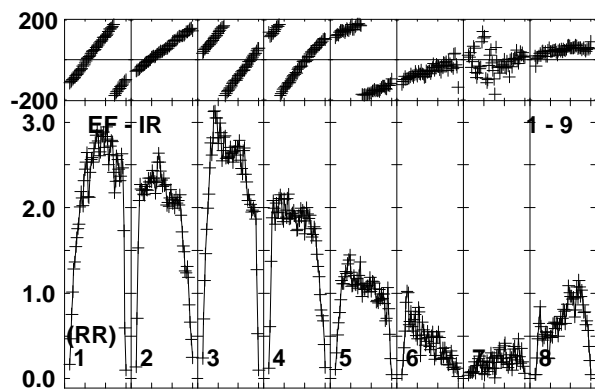
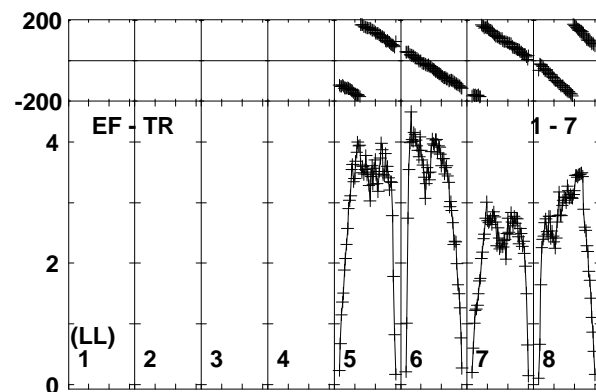
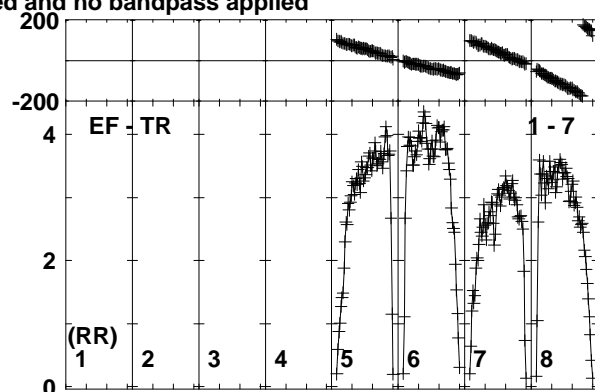
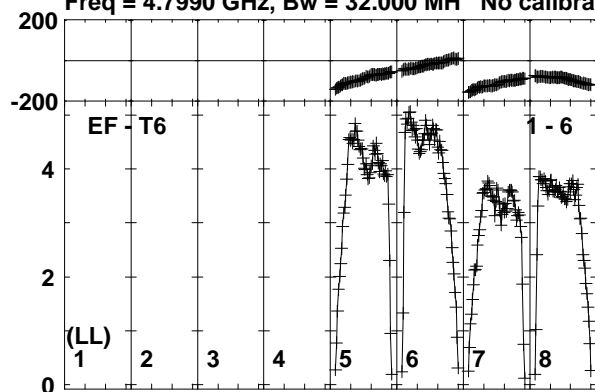

Lower frame: Milli Ampl Jy Top frame: Phas deg
Vector averaged cross-power spectrum Baseline: EF (01) - T6 (06)
Timerange: 00/08:56:39 to 00/08:58:09

Plot file version 139 created 03-OCT-2017 13:27:43

ARUMA EG096C.UVDATA.1

Freq = 4.7990 GHz, Bw = 32.000 MH No calibration applied and no bandpass applied

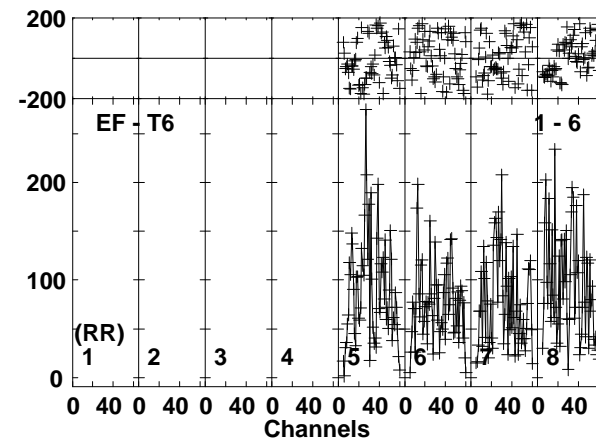
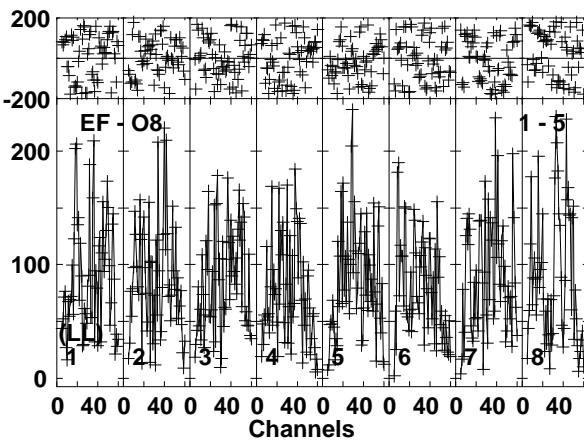
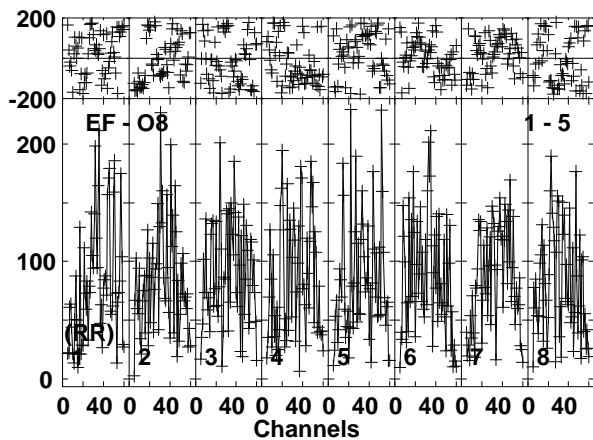
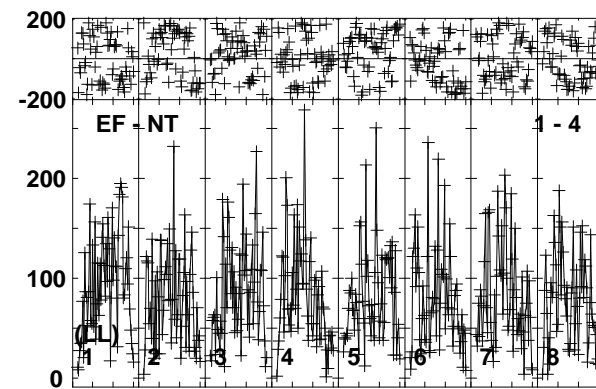
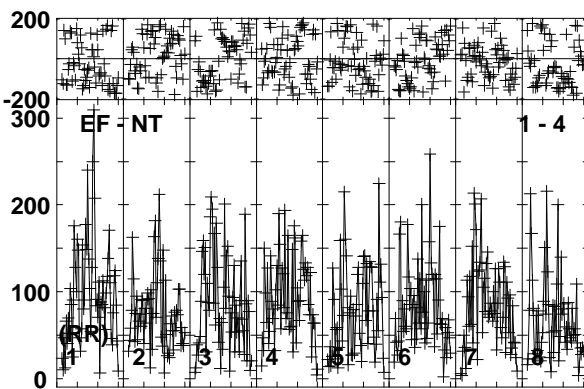
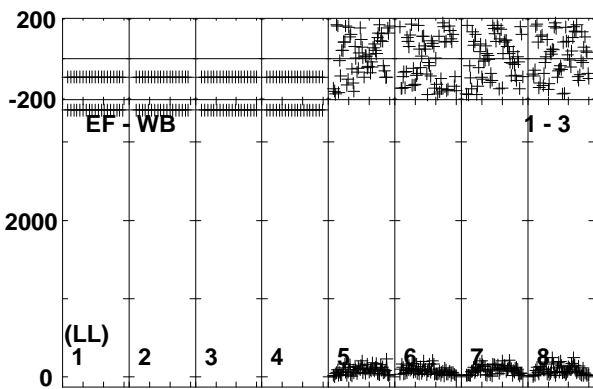
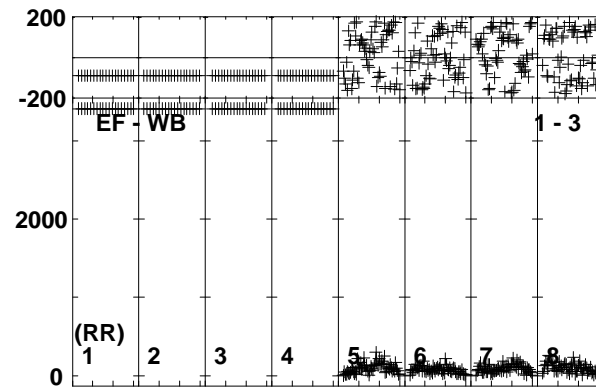
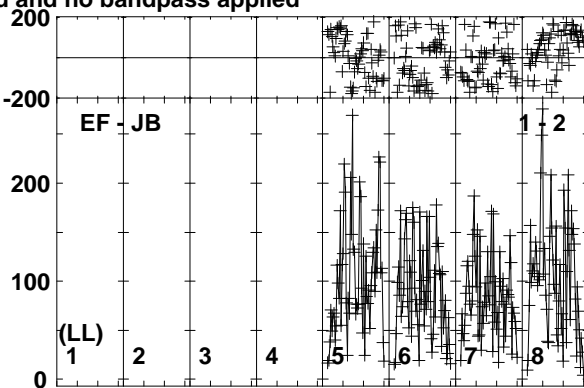
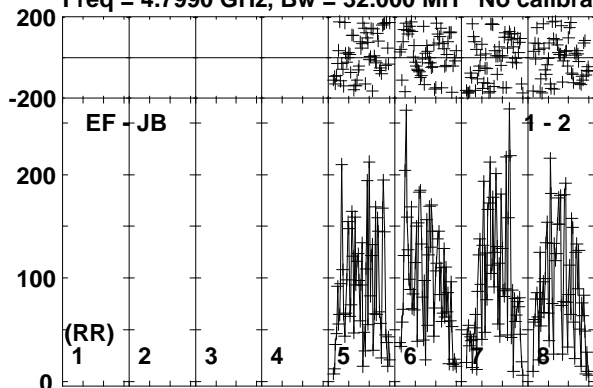

Lower frame: Micro Ampl Jy Top frame: Phas deg
Vector averaged cross-power spectrum Baseline: EF (01) - JB (02)
Timerange: 00/08:58:09 to 00/09:01:38

Plot file version 140 created 03-OCT-2017 13:27:43

ARUMA EG096C.UVDATA.1

Freq = 4.7990 GHz, Bw = 32.000 MH No calibration applied and no bandpass applied

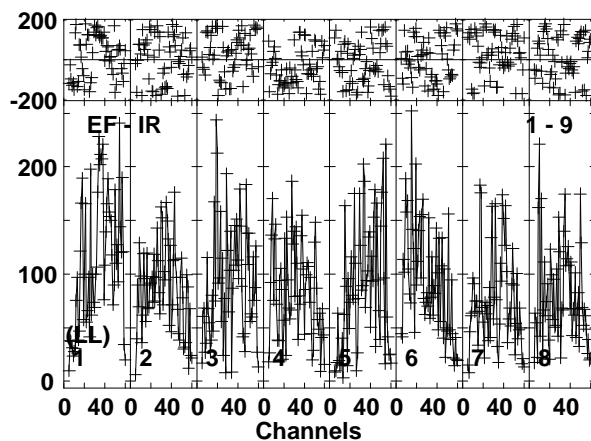
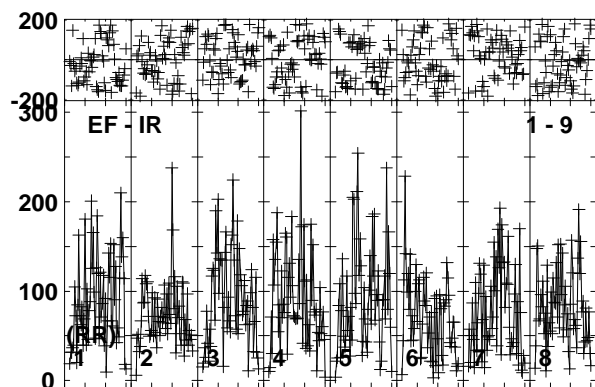
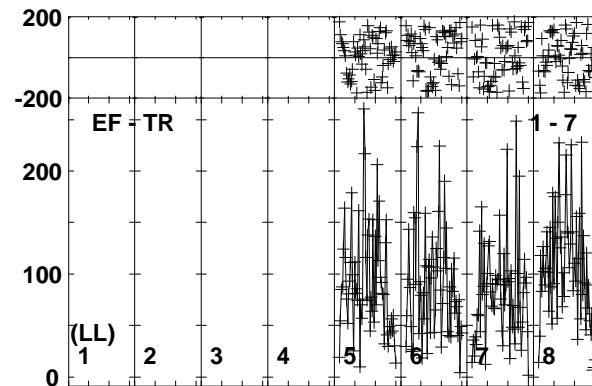
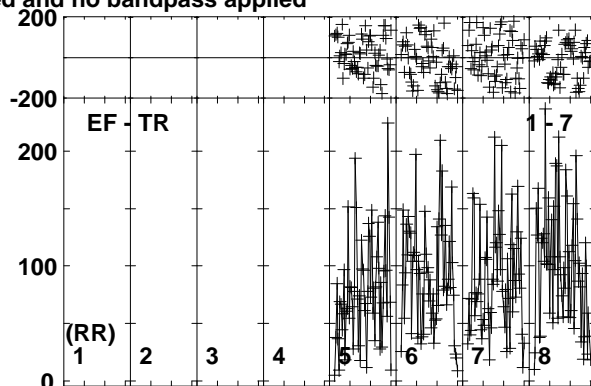
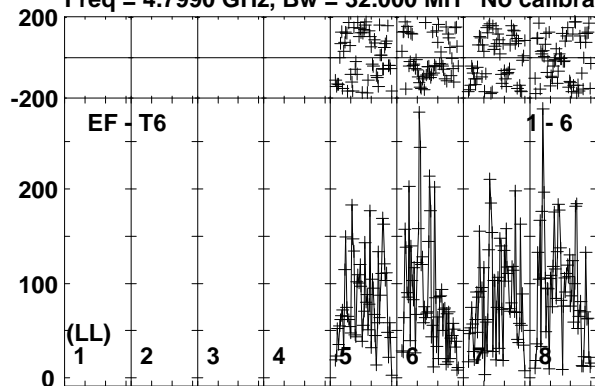

Lower frame: Micro Ampl Jy Top frame: Phas deg
Vector averaged cross-power spectrum Baseline: EF (01) - T6 (06)
Timerange: 00/08:58:09 to 00/09:01:38

Plot file version 141 created 03-OCT-2017 13:27:44

J1108+4330 EG096C.UVDATA.1

Freq = 4.7990 GHz, Bw = 32.000 MH No calibration applied and no bandpass applied

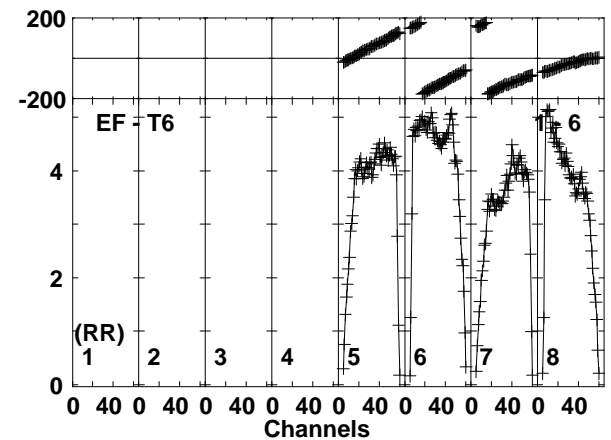
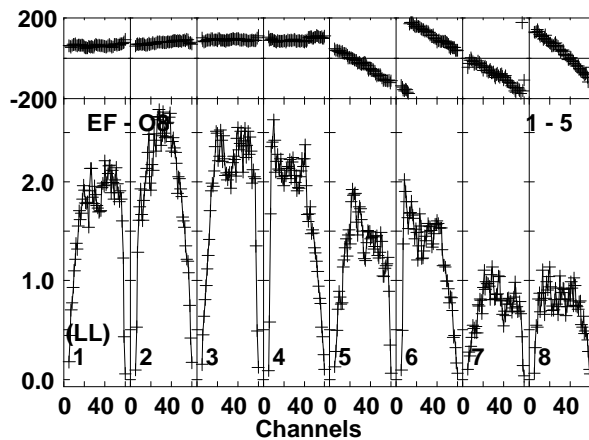
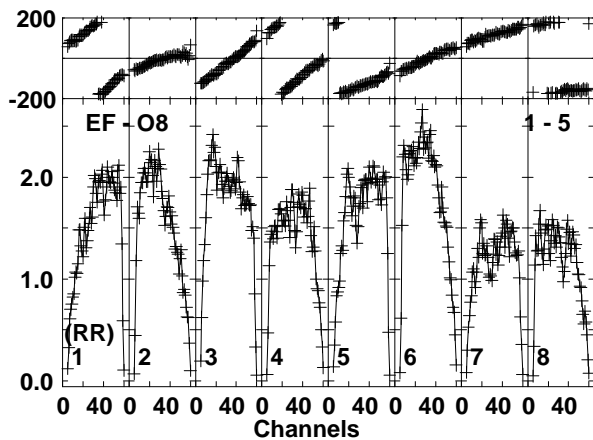
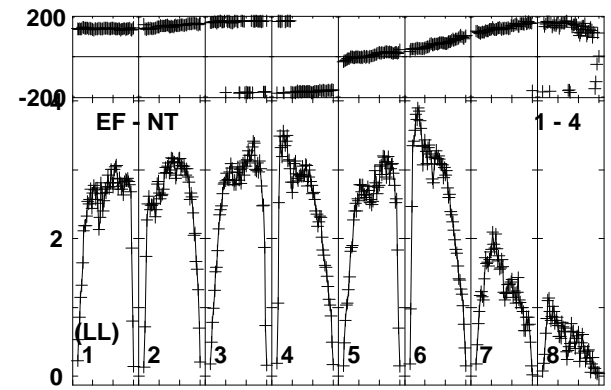
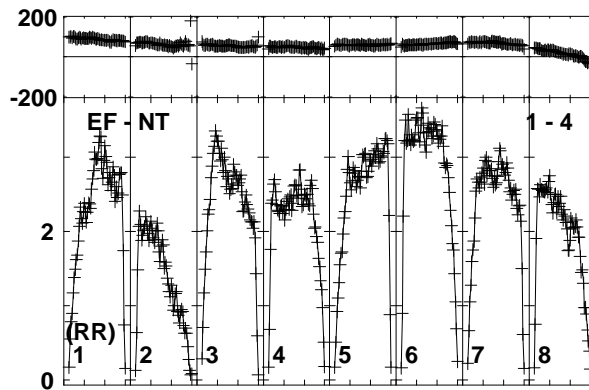
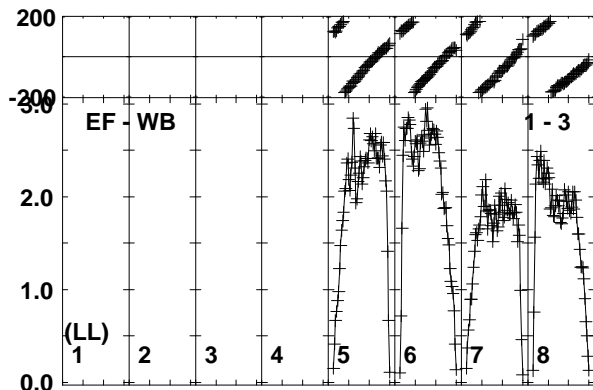
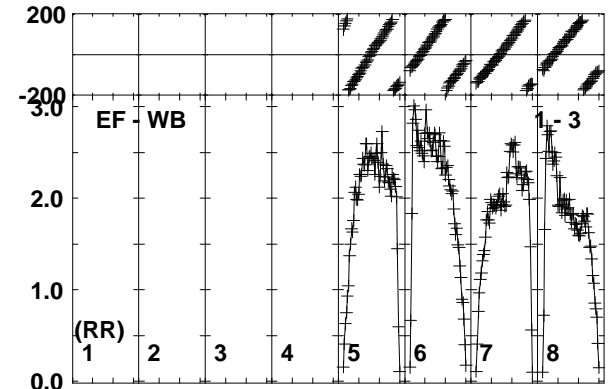
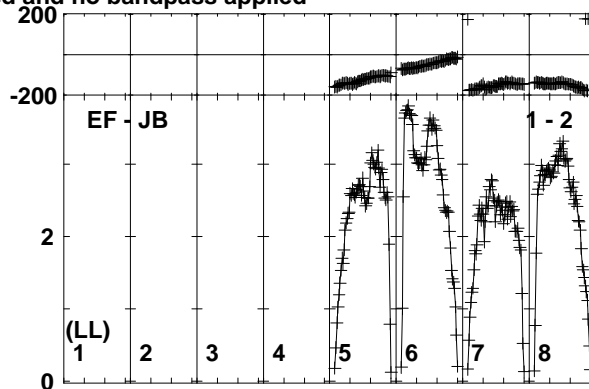
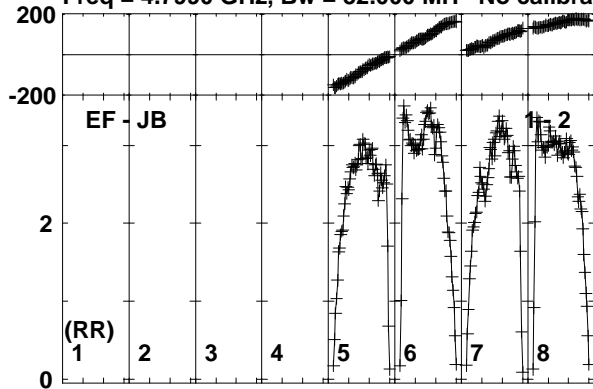

Lower frame: Milli Ampl Jy Top frame: Phas deg
Vector averaged cross-power spectrum Baseline: EF (01) - JB (02)
Timerange: 00/09:02:19 to 00/09:03:19

Plot file version 142 created 03-OCT-2017 13:27:44

J1108+4330 EG096C.UVDATA.1

Freq = 4.7990 GHz, Bw = 32.000 MH No calibration applied and no bandpass applied

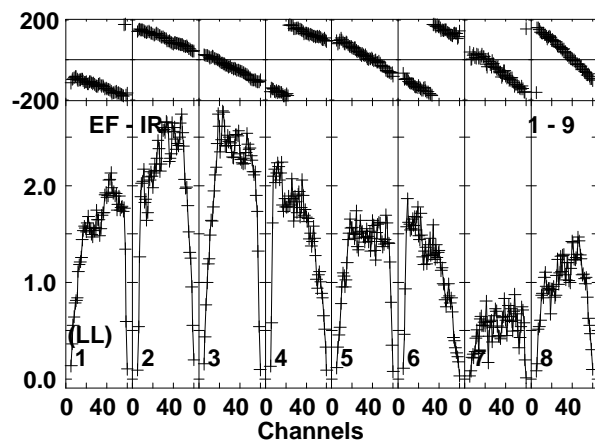
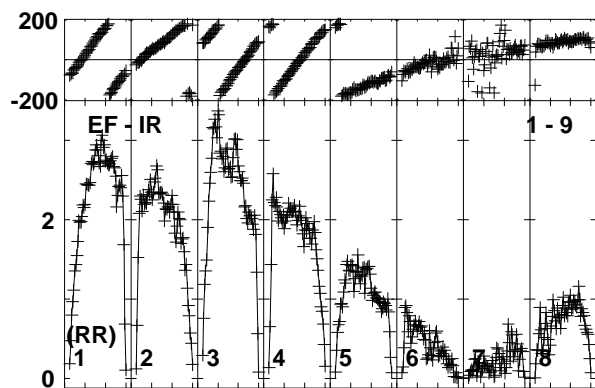
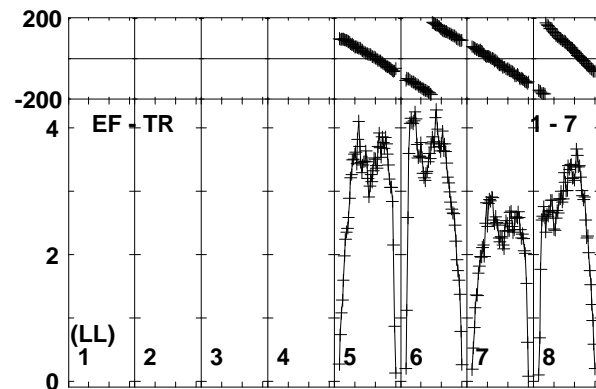
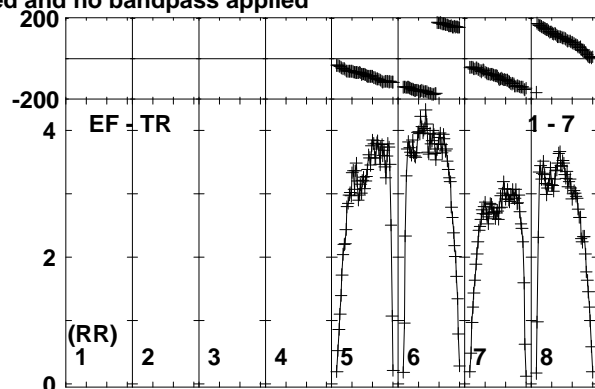
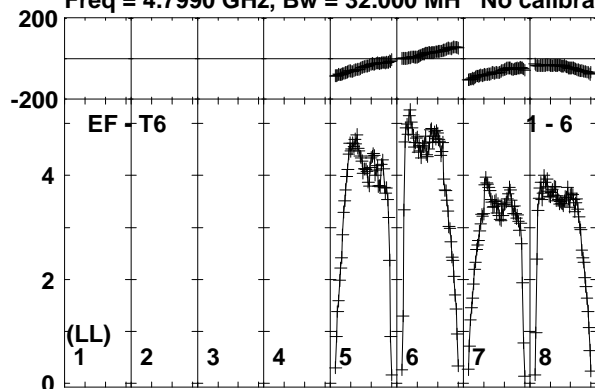

Lower frame: Milli Ampl Jy Top frame: Phas deg
Vector averaged cross-power spectrum Baseline: EF (01) - T6 (06)
Timerange: 00/09:02:19 to 00/09:03:19

Plot file version 143 created 03-OCT-2017 13:27:44

ARUMA EG096C.UVDATA.1

Freq = 4.7990 GHz, Bw = 32.000 MH No calibration applied and no bandpass applied

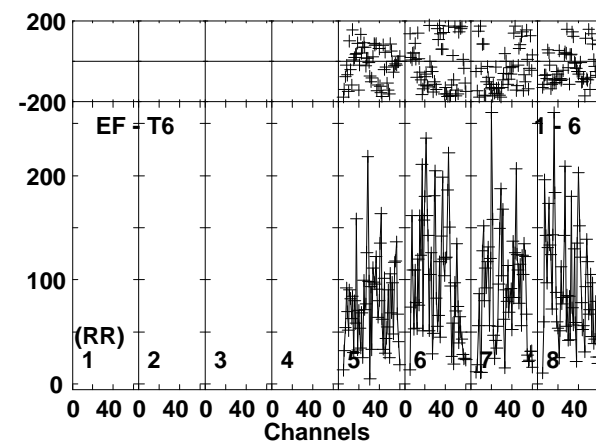
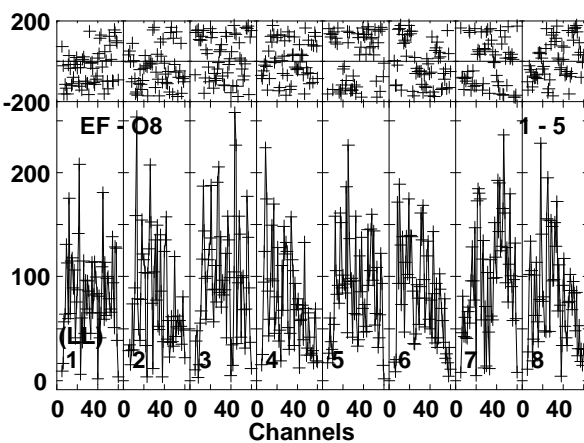
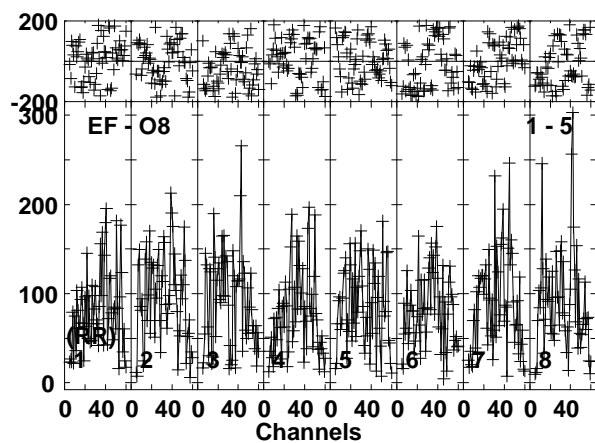
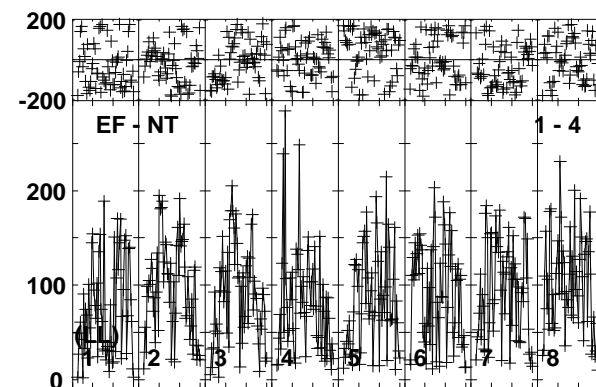
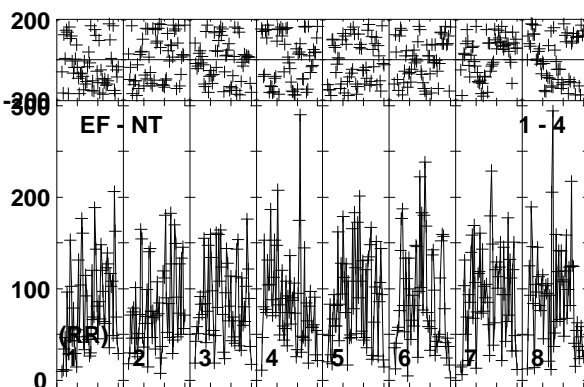
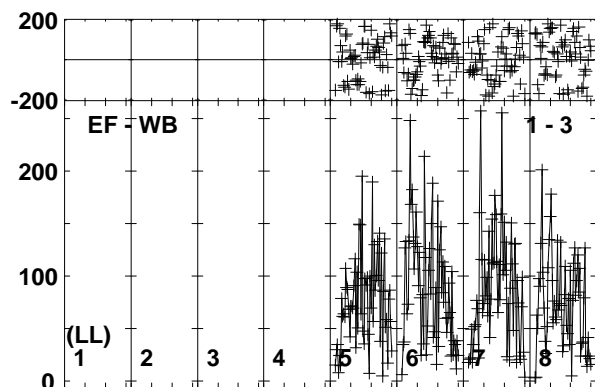
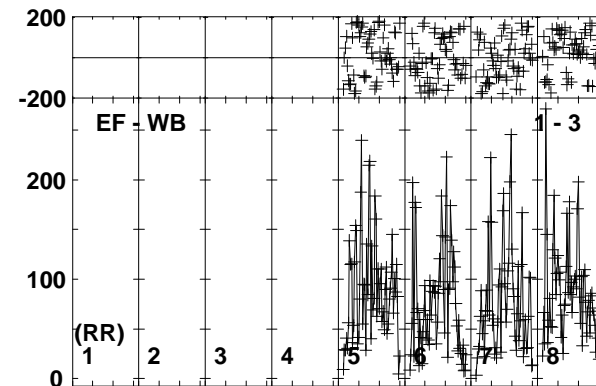
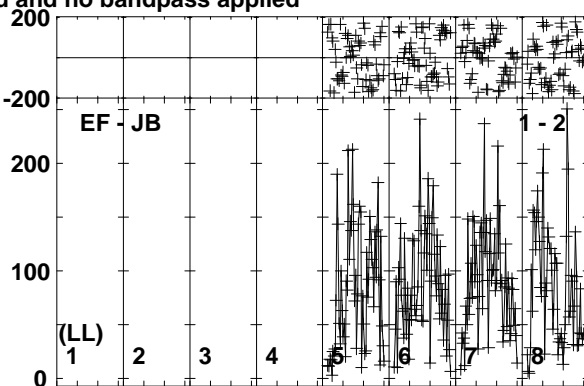
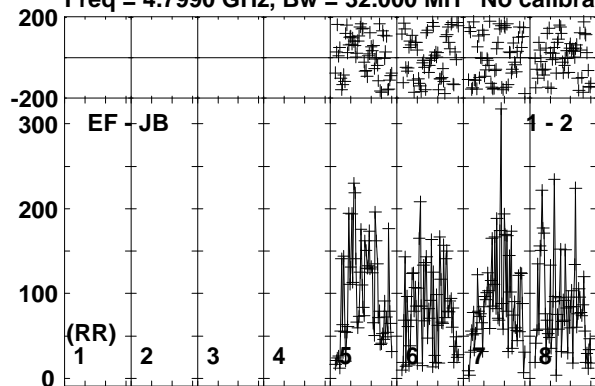

Lower frame: Micro Ampl Jy Top frame: Phas deg
Vector averaged cross-power spectrum Baseline: EF (01) - JB (02)
Timerange: 00/09:03:19 to 00/09:06:48

Plot file version 144 created 03-OCT-2017 13:27:44

ARUMA EG096C.UVDATA.1

Freq = 4.7990 GHz, Bw = 32.000 MH No calibration applied and no bandpass applied

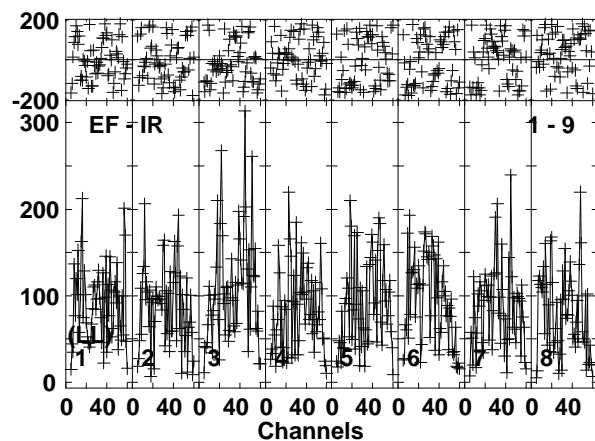
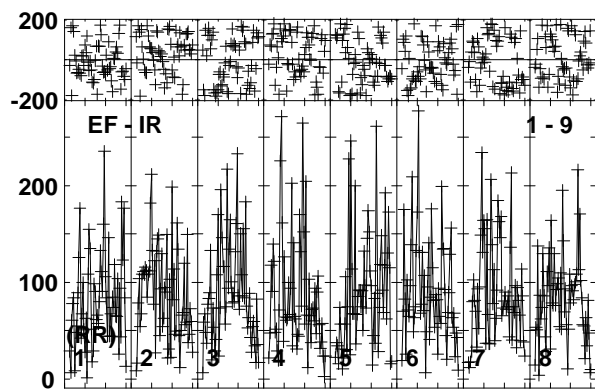
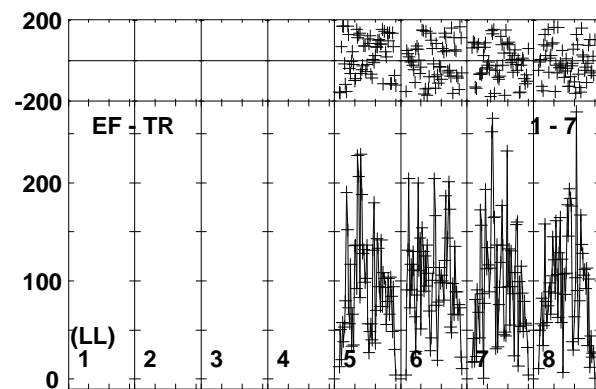
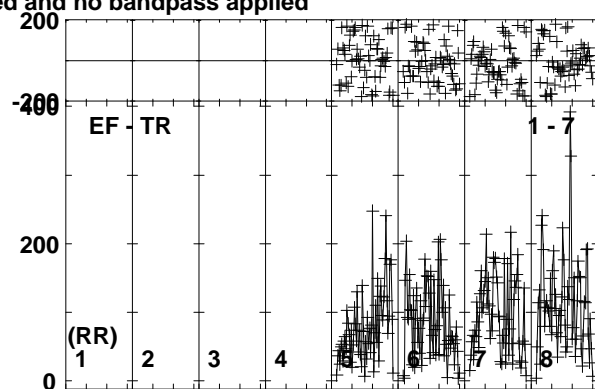
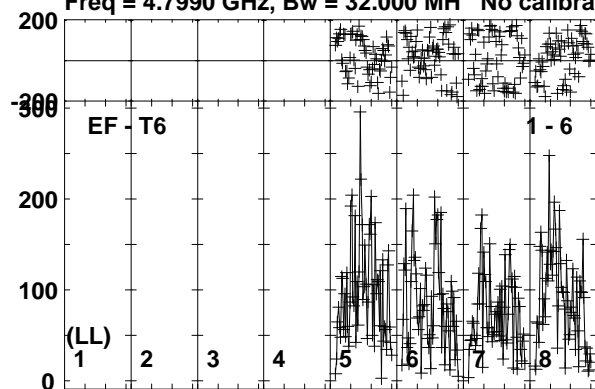

Lower frame: Micro Ampl Jy Top frame: Phas deg
Vector averaged cross-power spectrum Baseline: EF (01) - T6 (06)
Timerange: 00/09:03:19 to 00/09:06:48

Plot file version 145 created 03-OCT-2017 13:27:45

J1108+4330 EG096C.UVDATA.1

Freq = 4.7990 GHz, Bw = 32.000 MH No calibration applied and no bandpass applied

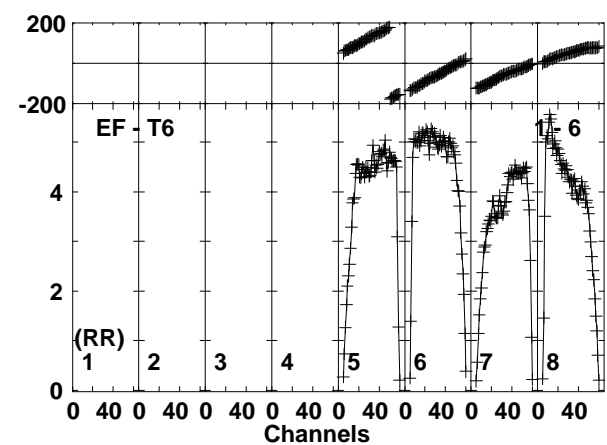
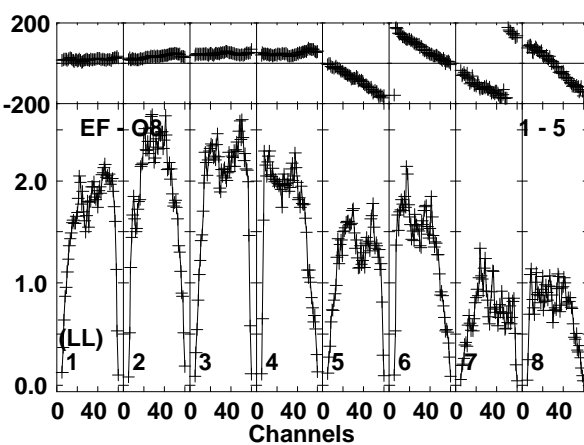
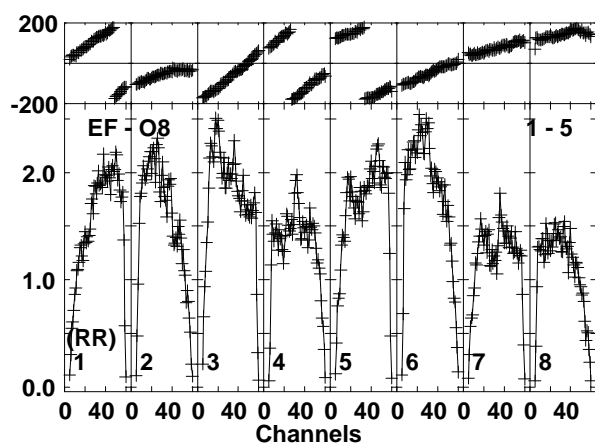
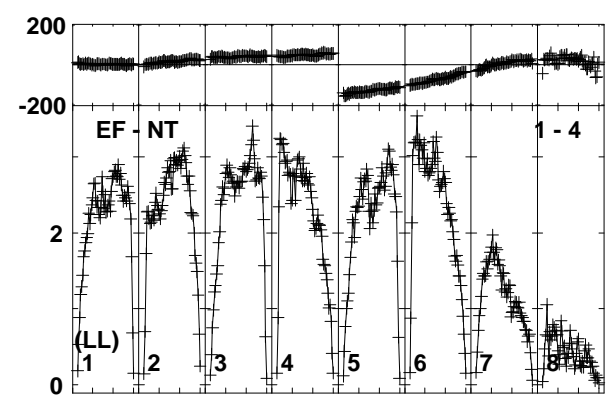
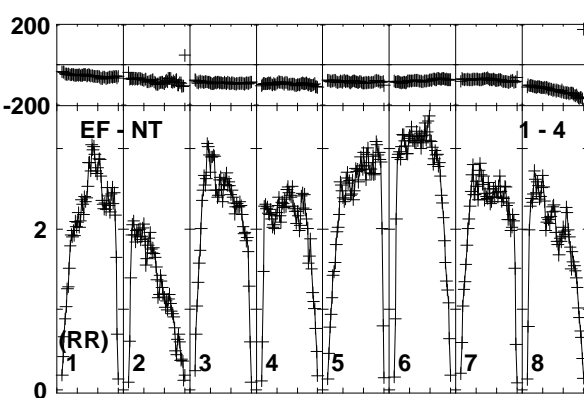
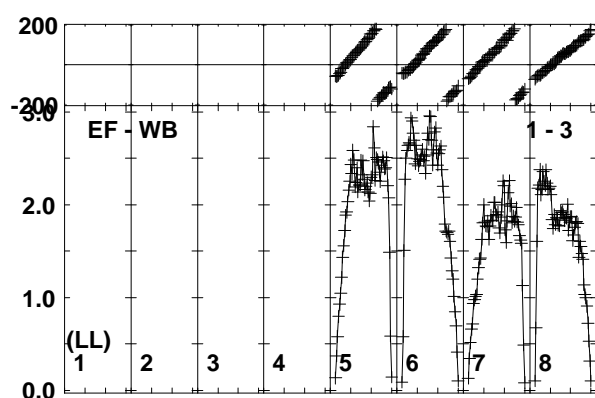
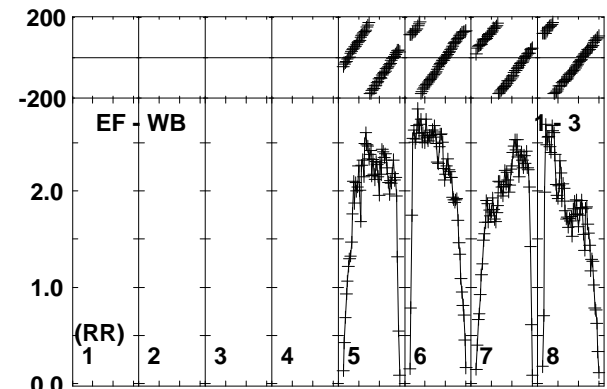
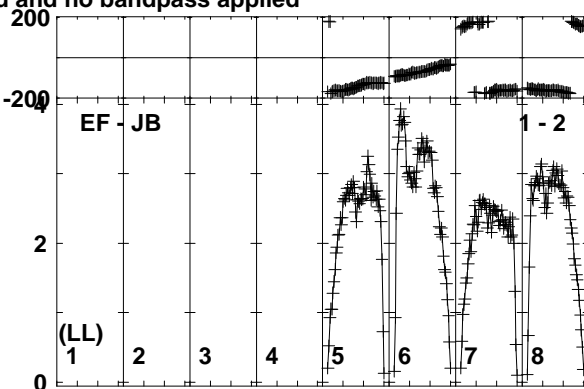
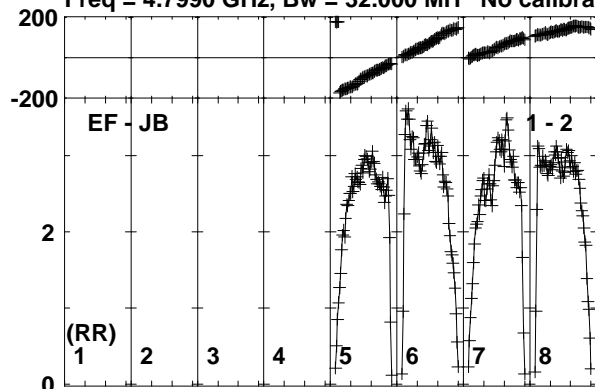

Lower frame: Milli Ampl Jy Top frame: Phas deg
Vector averaged cross-power spectrum Baseline: EF (01) - JB (02)
Timerange: 00/09:06:50 to 00/09:08:18

Plot file version 146 created 03-OCT-2017 13:27:45

J1108+4330 EG096C.UVDATA.1

Freq = 4.7990 GHz, Bw = 32.000 MH No calibration applied and no bandpass applied

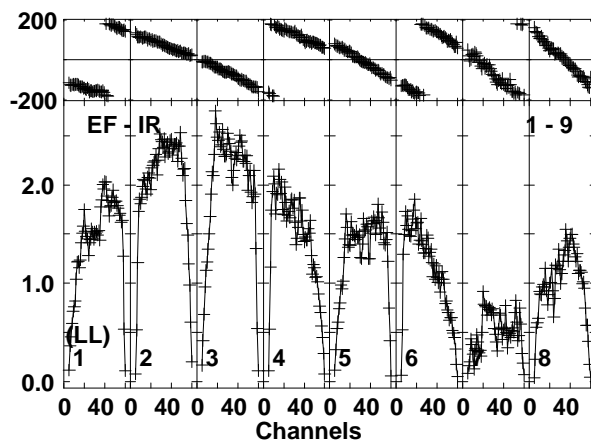
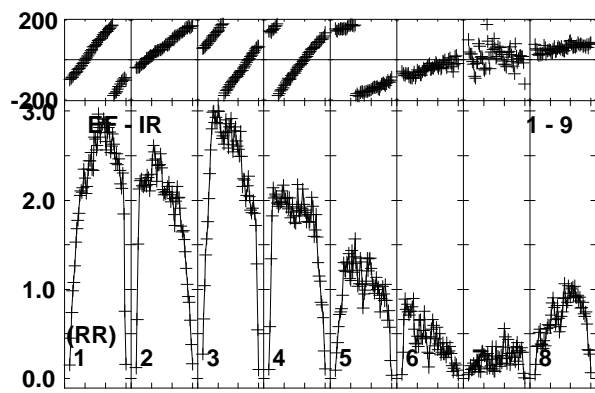
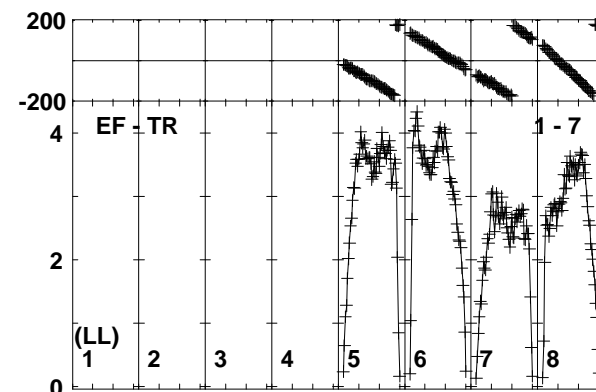
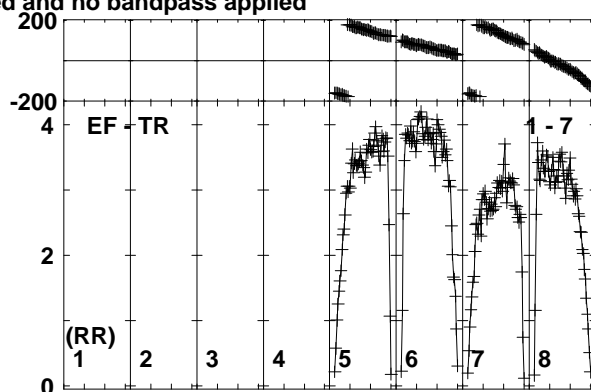
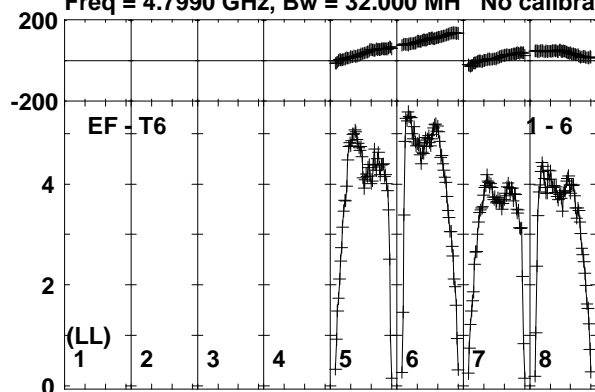

Lower frame: Milli Ampl Jy Top frame: Phas deg
Vector averaged cross-power spectrum Baseline: EF (01) - T6 (06)
Timerange: 00/09:06:50 to 00/09:08:18

Plot file version 147 created 03-OCT-2017 13:27:45

ARUMA EG096C.UVDATA.1

Freq = 4.7990 GHz, Bw = 32.000 MH No calibration applied and no bandpass applied

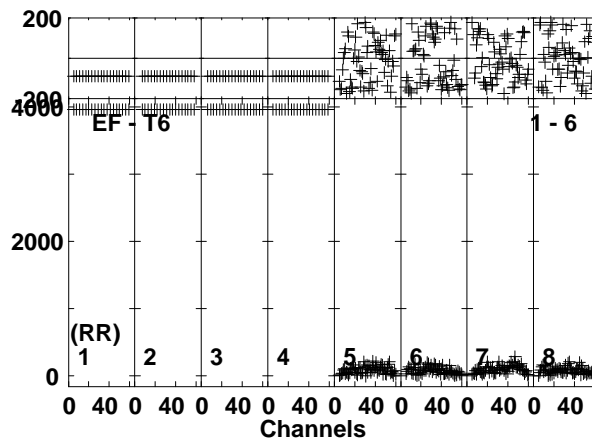
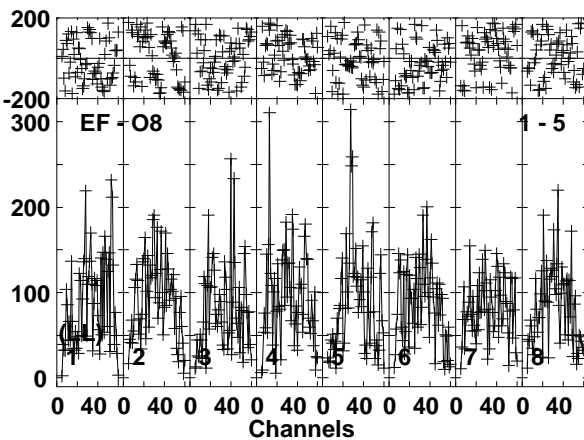
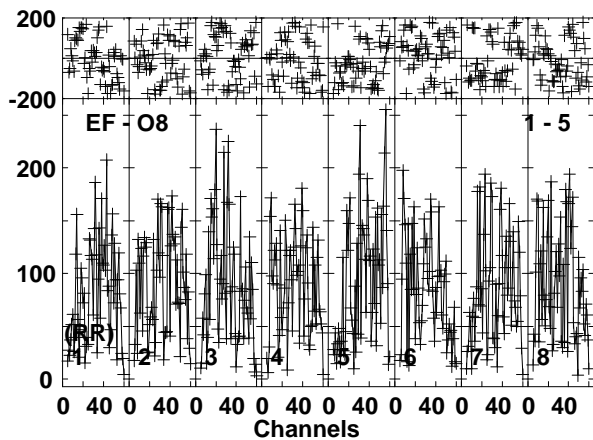
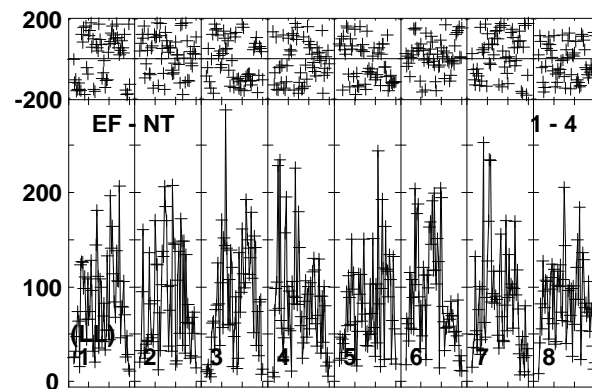
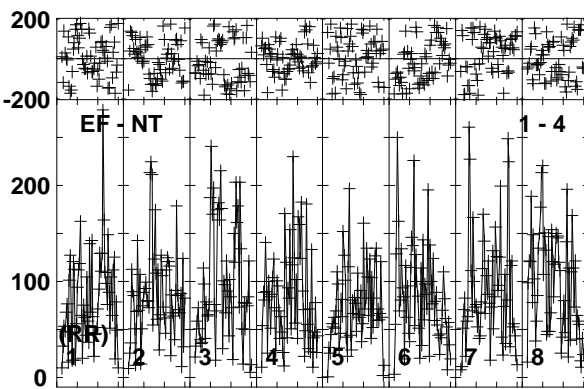
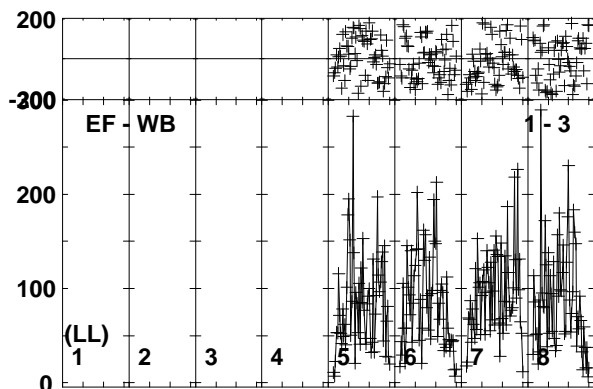
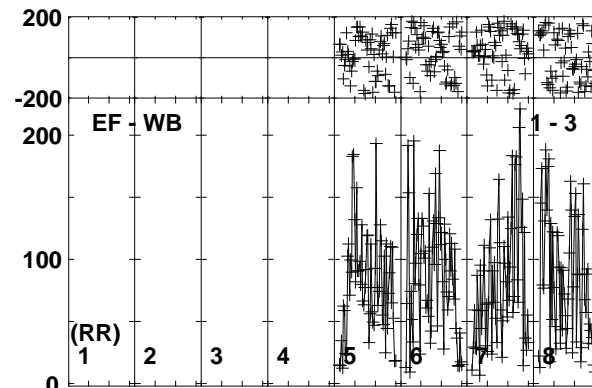
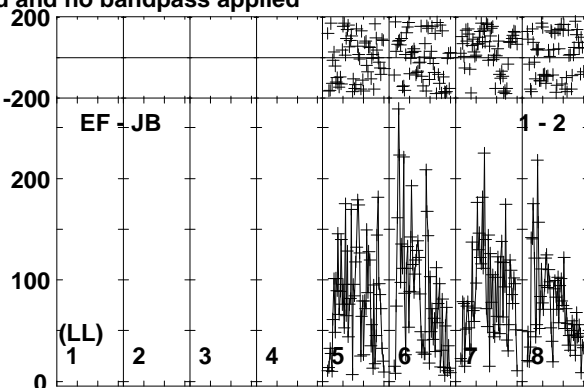
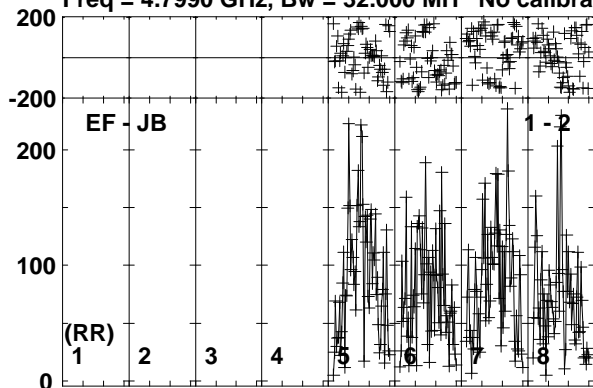

Lower frame: Micro Ampl Jy Top frame: Phas deg
Vector averaged cross-power spectrum Baseline: EF (01) - JB (02)
Timerange: 00/09:08:20 to 00/09:11:49

Plot file version 148 created 03-OCT-2017 13:27:45

ARUMA EG096C.UVDATA.1

Freq = 4.7990 GHz, Bw = 32.000 MH No calibration applied and no bandpass applied

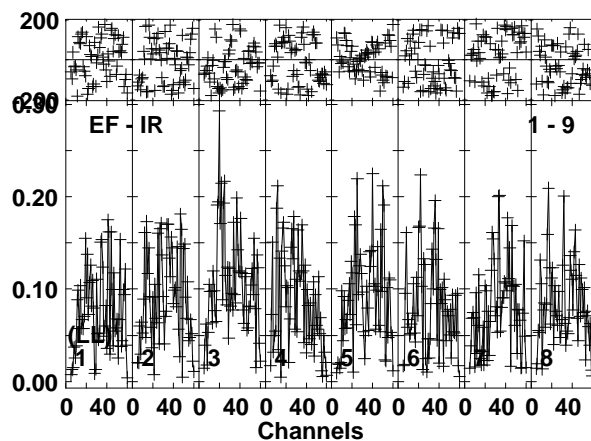
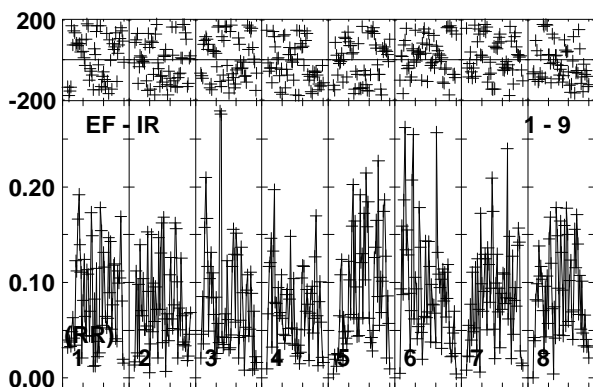
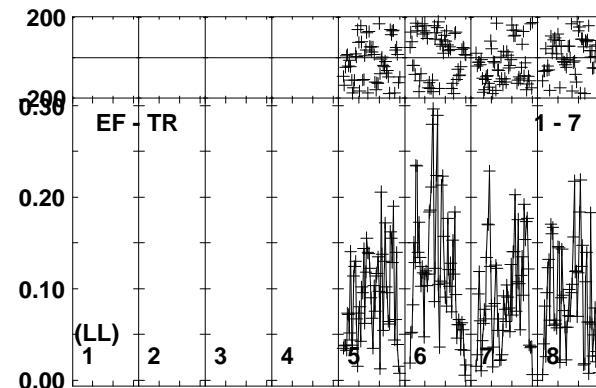
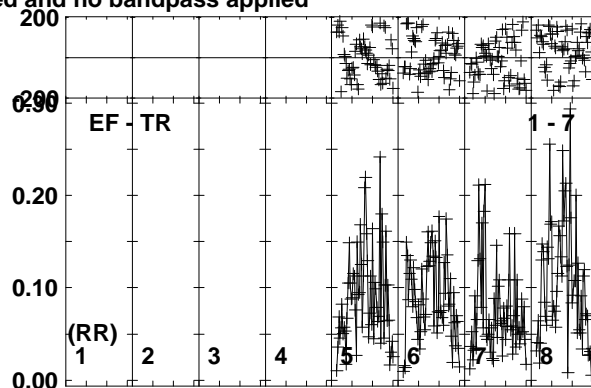
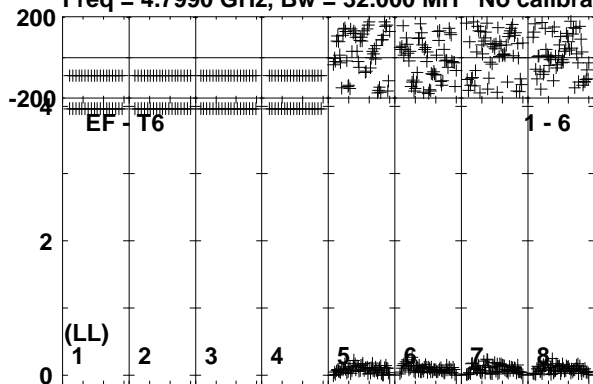

Lower frame: Milli Ampl Jy Top frame: Phas deg
Vector averaged cross-power spectrum Baseline: EF (01) - T6 (06)
Timerange: 00/09:08:20 to 00/09:11:49

Plot file version 149 created 03-OCT-2017 13:27:46

J1108+4330 EG096C.UVDATA.1

Freq = 4.7990 GHz, Bw = 32.000 MH No calibration applied and no bandpass applied

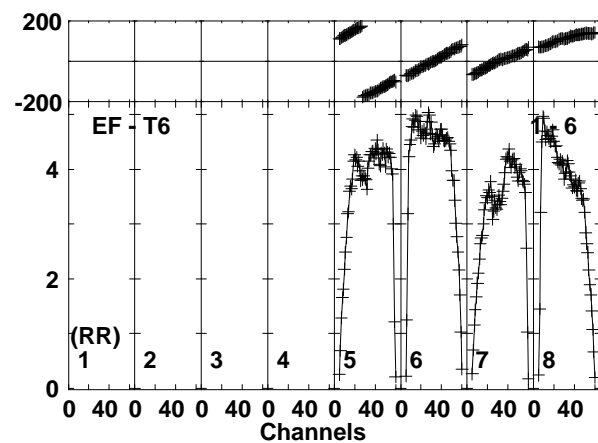
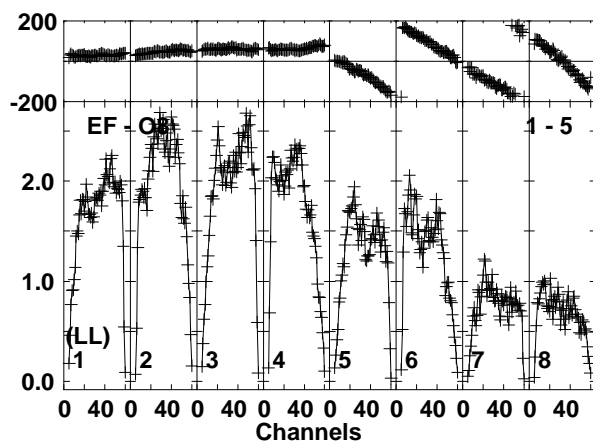
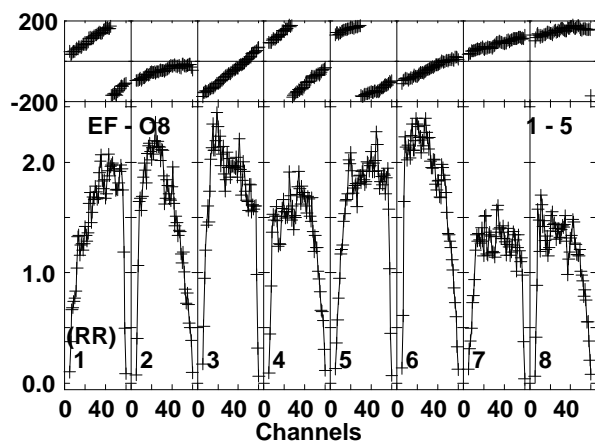
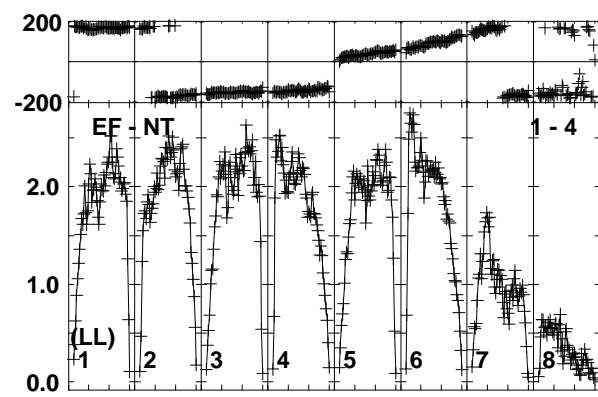
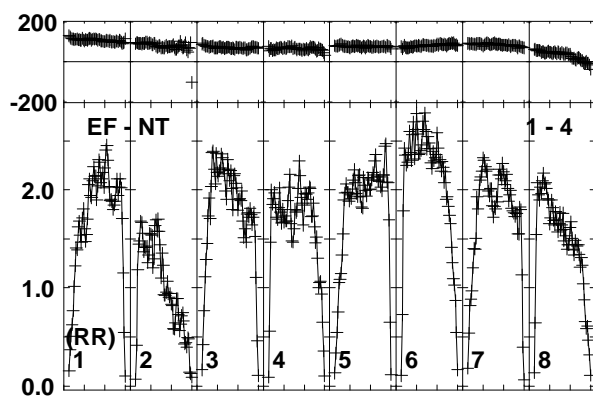
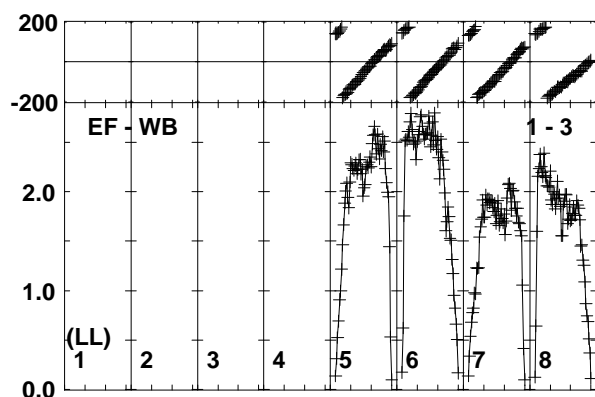
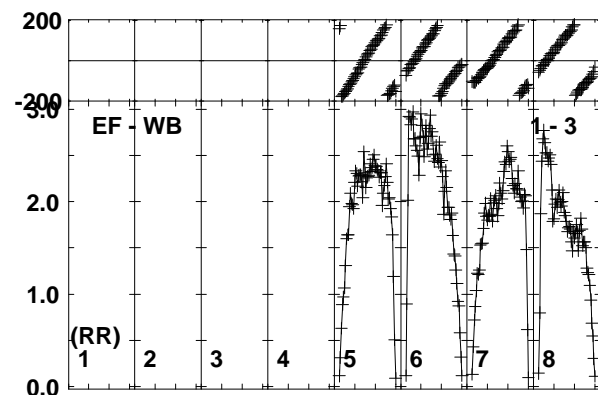
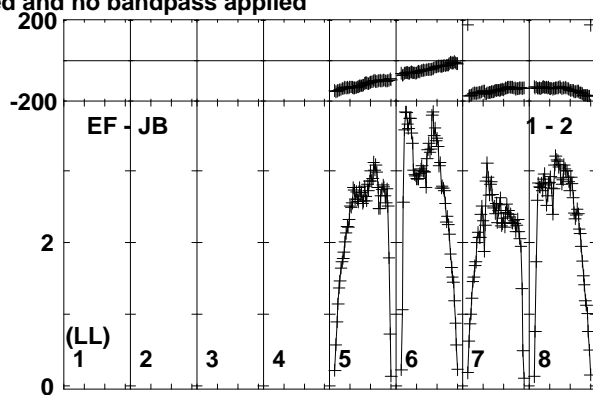
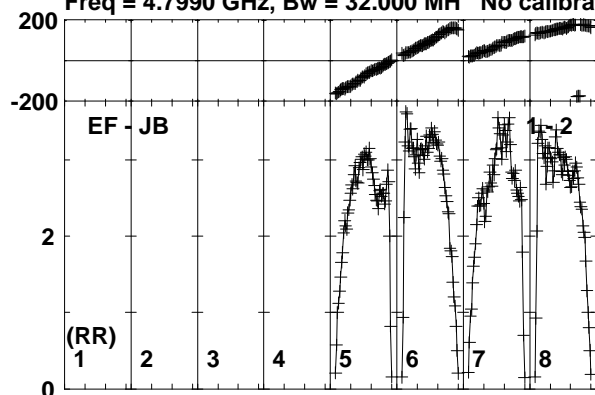

Lower frame: Milli Ampl Jy Top frame: Phas deg
Vector averaged cross-power spectrum Baseline: EF (01) - JB (02)
Timerange: 00/09:12:30 to 00/09:13:28

Plot file version 150 created 03-OCT-2017 13:27:46

J1108+4330 EG096C.UVDATA.1

Freq = 4.7990 GHz, Bw = 32.000 MH No calibration applied and no bandpass applied

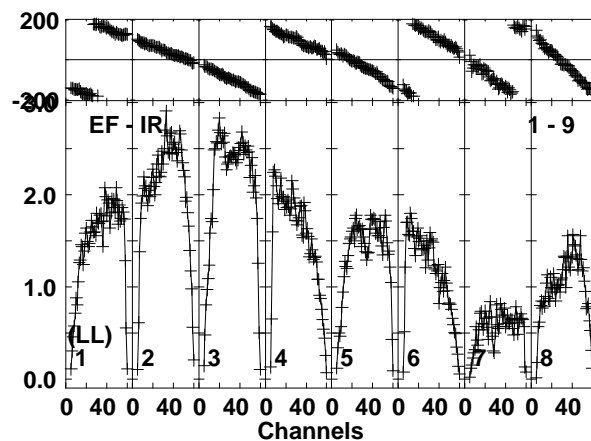
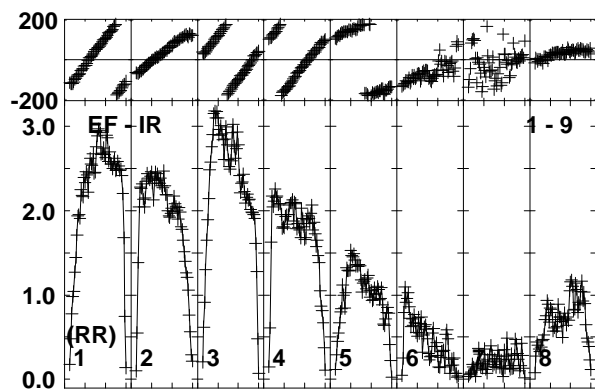
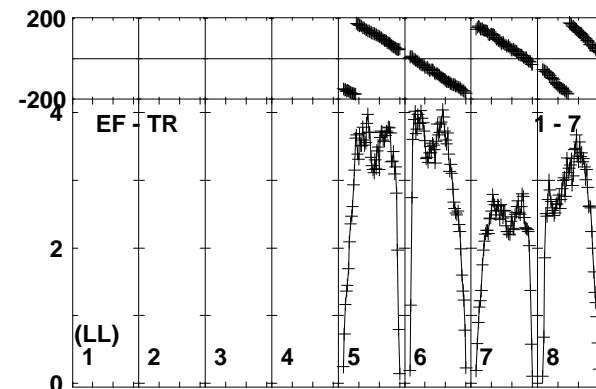
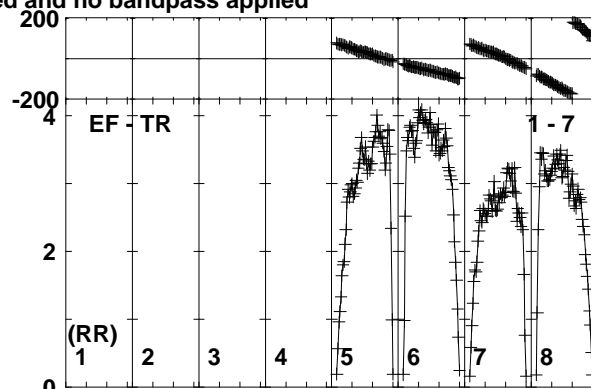
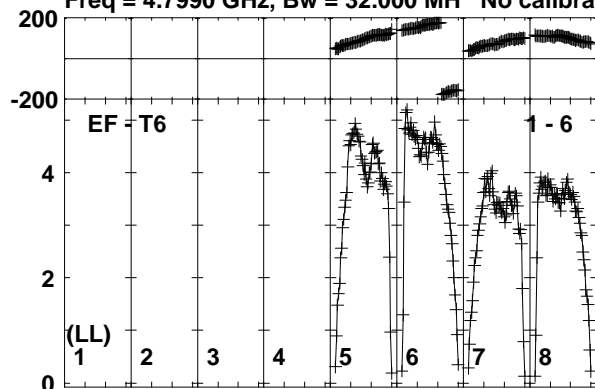

Lower frame: Milli Ampl Jy Top frame: Phas deg
Vector averaged cross-power spectrum Baseline: EF (01) - T6 (06)
Timerange: 00/09:12:30 to 00/09:13:28

Plot file version 151 created 03-OCT-2017 13:27:46

J1112+4301 EG096C.UVDATA.1

Freq = 4.7990 GHz, Bw = 32.000 MH No calibration applied and no bandpass applied

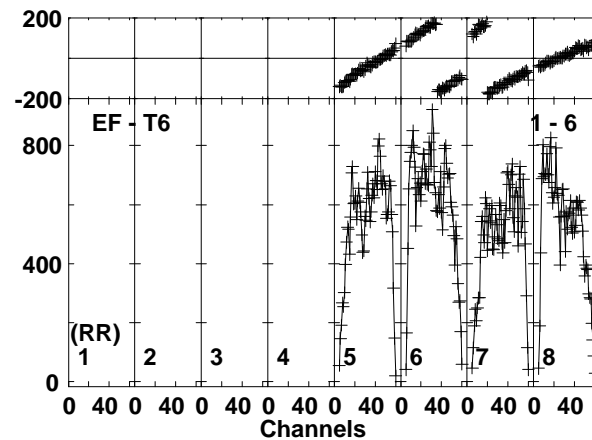
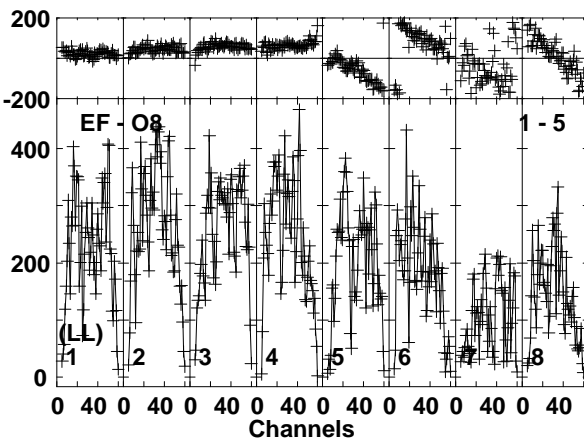
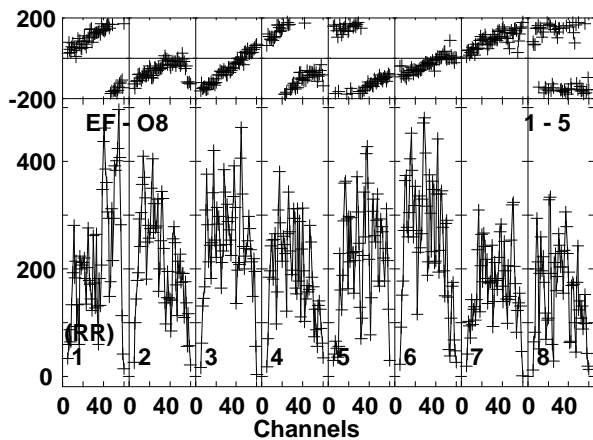
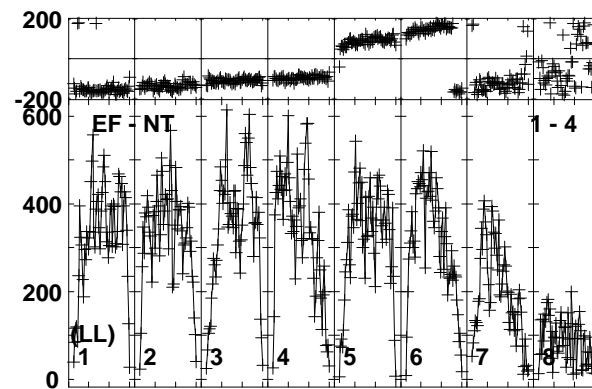
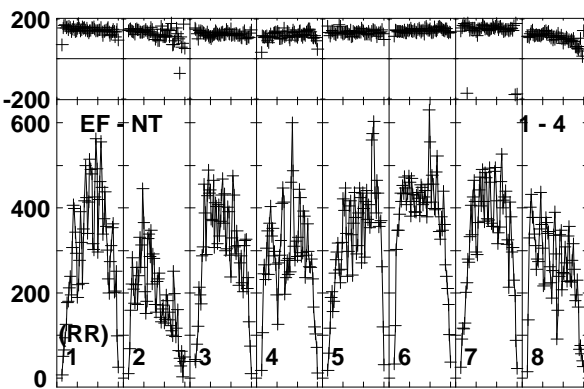
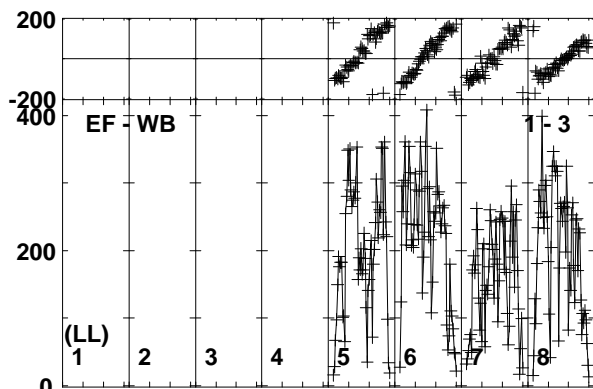
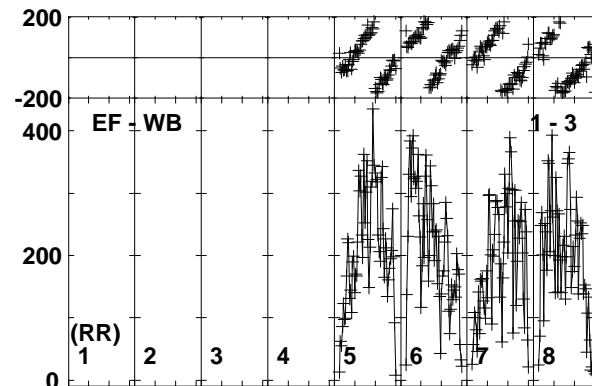
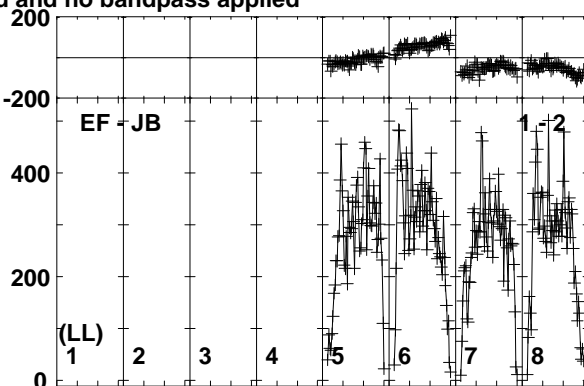
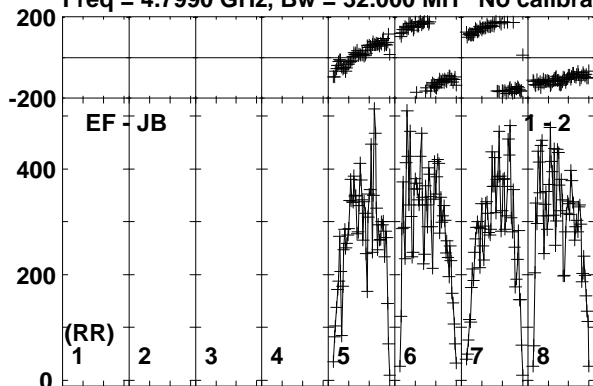

Lower frame: Micro Ampl Jy Top frame: Phas deg
Vector averaged cross-power spectrum Baseline: EF (01) - JB (02)
Timerange: 00/09:13:30 to 00/09:16:59

Plot file version 152 created 03-OCT-2017 13:27:46

J1112+4301 EG096C.UVDATA.1

Freq = 4.7990 GHz, Bw = 32.000 MH No calibration applied and no bandpass applied

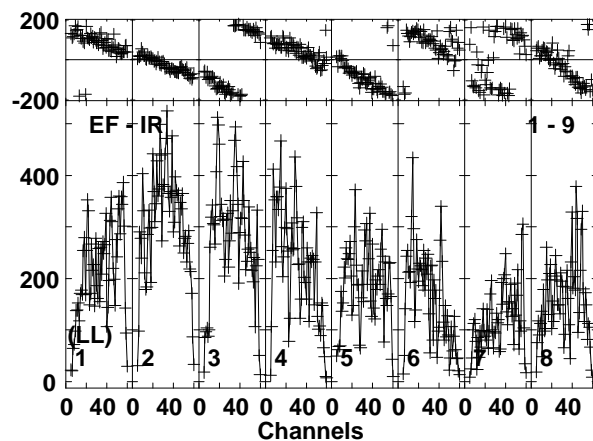
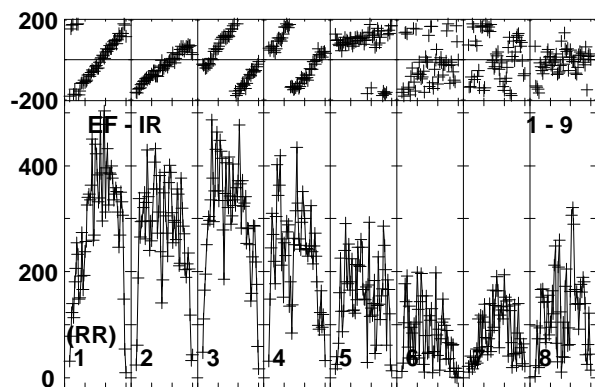
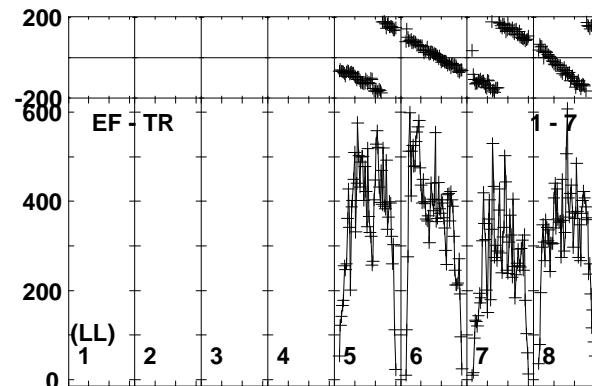
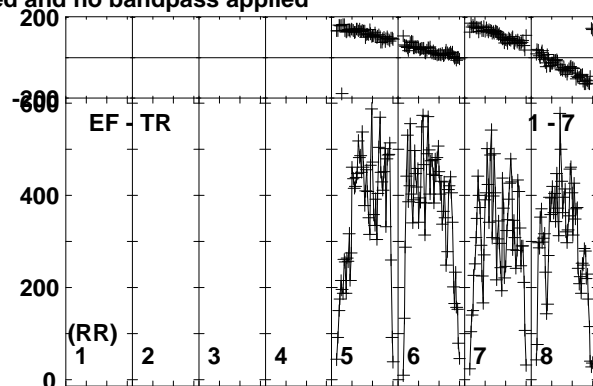
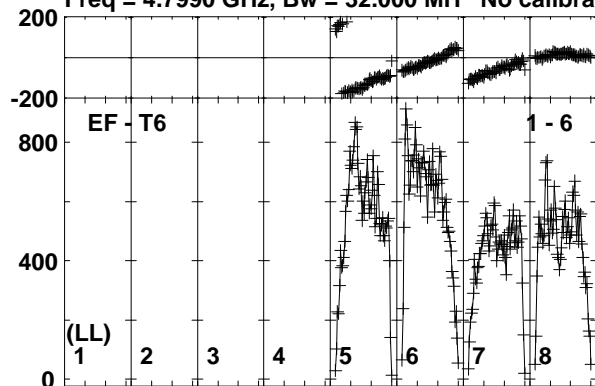

Lower frame: Micro Ampl Jy Top frame: Phas deg
Vector averaged cross-power spectrum Baseline: EF (01) - T6 (06)
Timerange: 00/09:13:30 to 00/09:16:59

Plot file version 153 created 03-OCT-2017 13:27:46

J1108+4330 EG096C.UVDATA.1

Freq = 4.7990 GHz, Bw = 32.000 MH No calibration applied and no bandpass applied

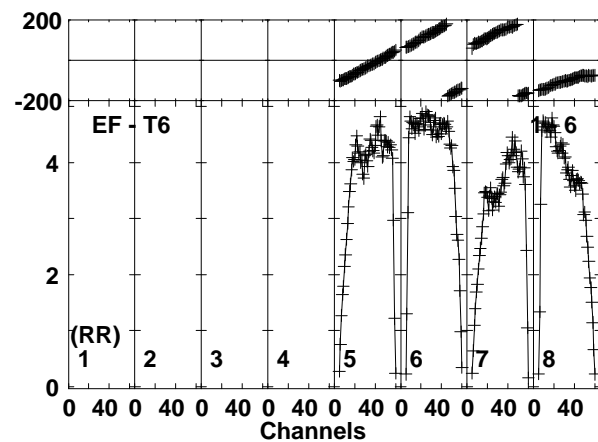
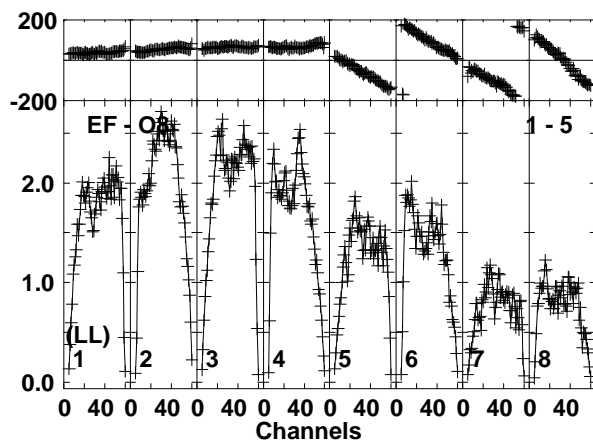
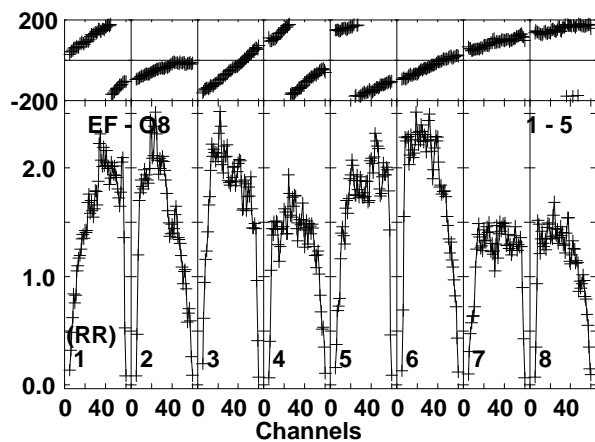
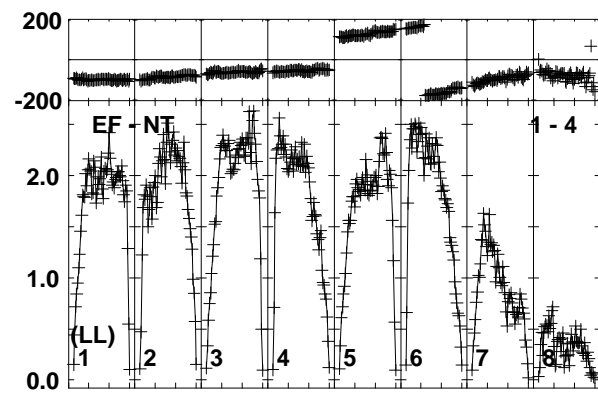
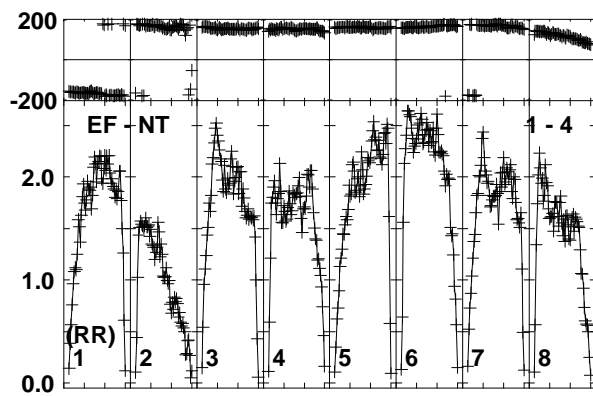
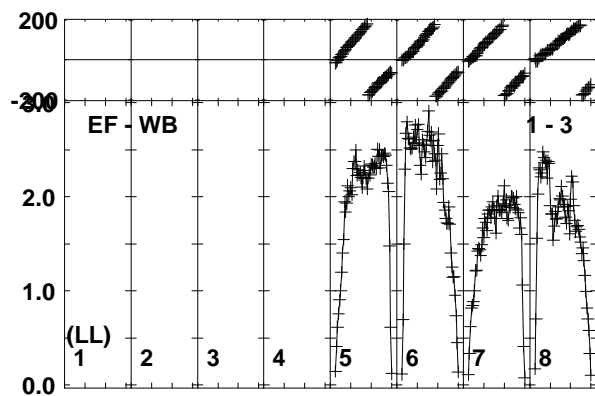
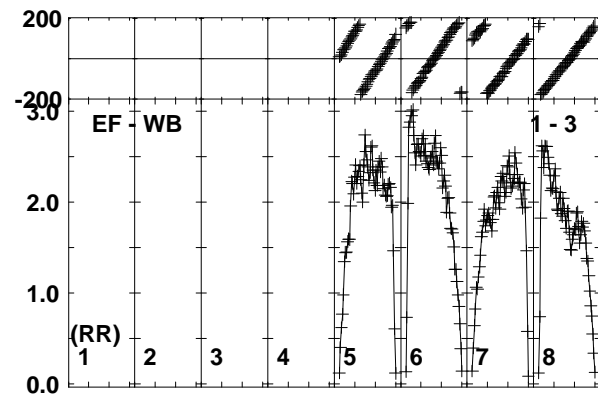
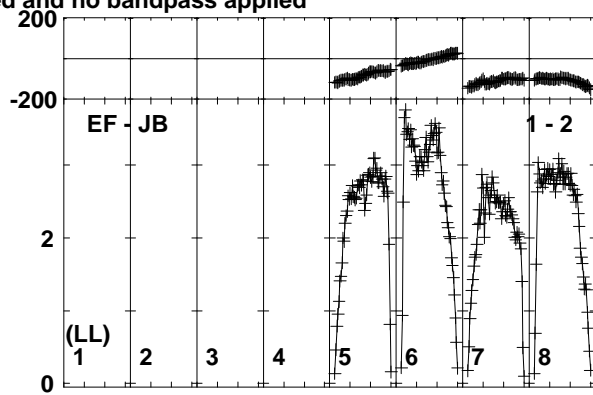
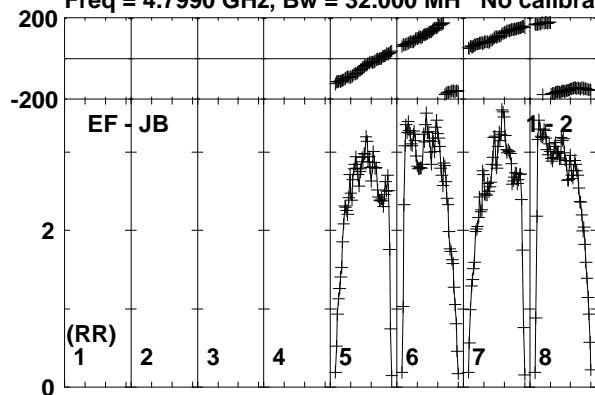

Lower frame: Milli Ampl Jy Top frame: Phas deg
Vector averaged cross-power spectrum Baseline: EF (01) - JB (02)
Timerange: 00/09:17:00 to 00/09:18:28

Plot file version 154 created 03-OCT-2017 13:27:47

J1108+4330 EG096C.UVDATA.1

Freq = 4.7990 GHz, Bw = 32.000 MH No calibration applied and no bandpass applied

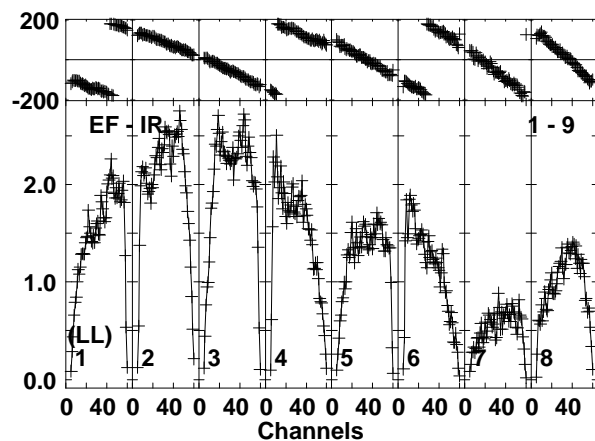
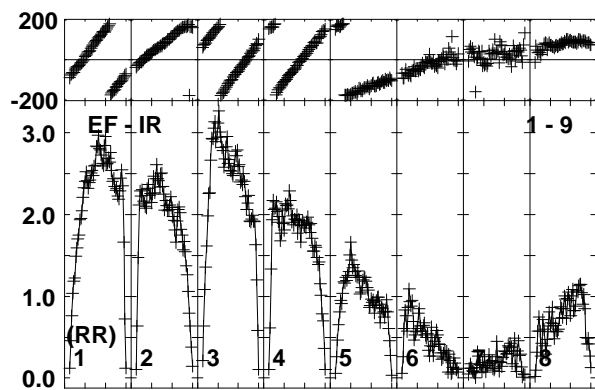
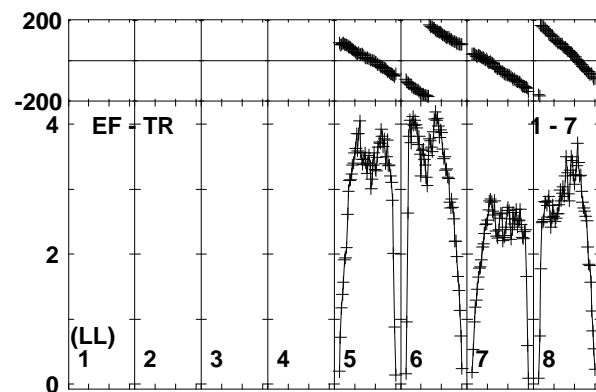
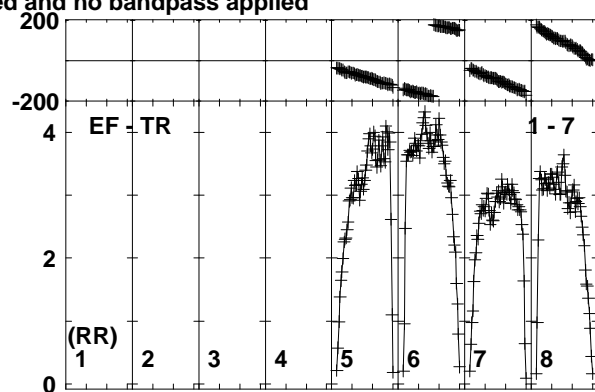
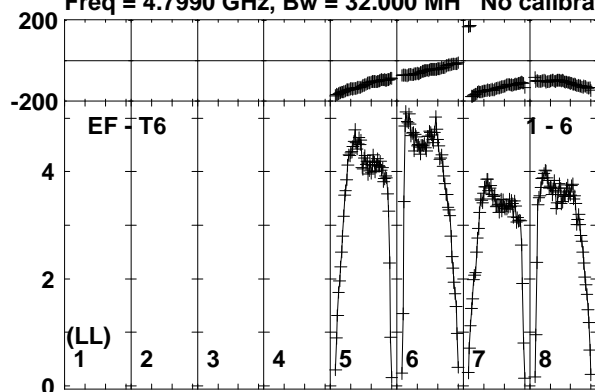

Lower frame: Milli Ampl Jy Top frame: Phas deg
Vector averaged cross-power spectrum Baseline: EF (01) - T6 (06)
Timerange: 00/09:17:00 to 00/09:18:28

Plot file version 155 created 03-OCT-2017 13:27:47

ARUMA EG096C.UVDATA.1

Freq = 4.7990 GHz, Bw = 32.000 MH No calibration applied and no bandpass applied

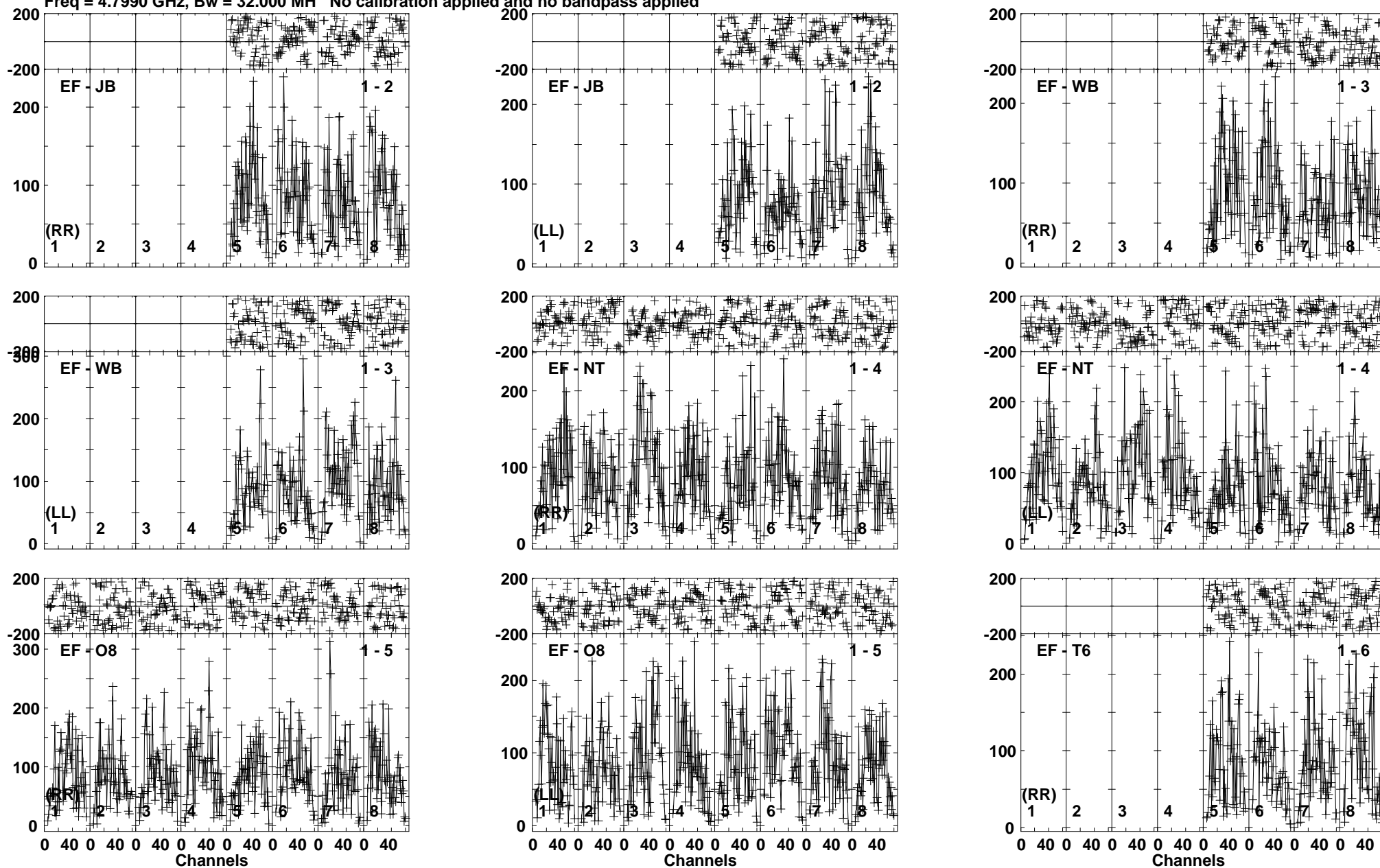

Lower frame: Micro Ampl Jy Top frame: Phas deg
Vector averaged cross-power spectrum Baseline: EF (01) - JB (02)
Timerange: 00/09:18:29 to 00/09:21:59

Plot file version 156 created 03-OCT-2017 13:27:47

ARUMA EG096C.UVDATA.1

Freq = 4.7990 GHz, Bw = 32.000 MH No calibration applied and no bandpass applied

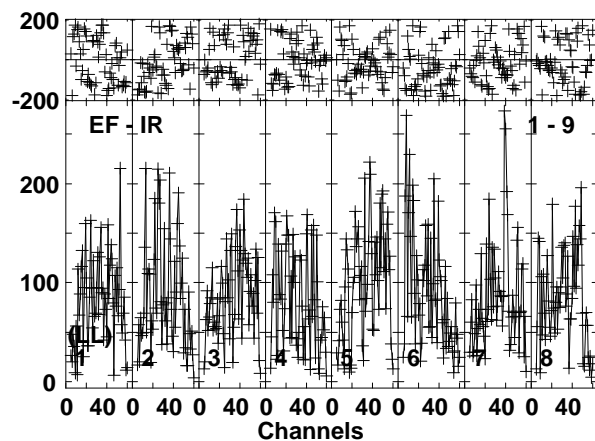
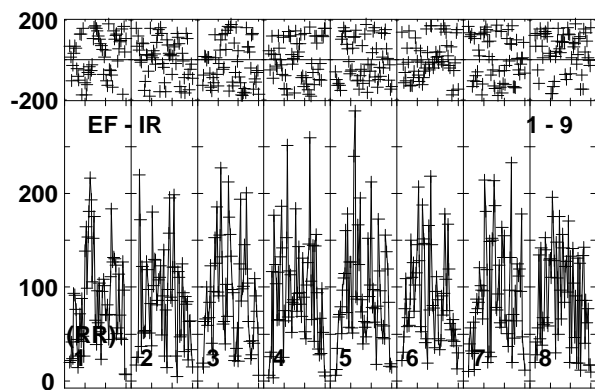
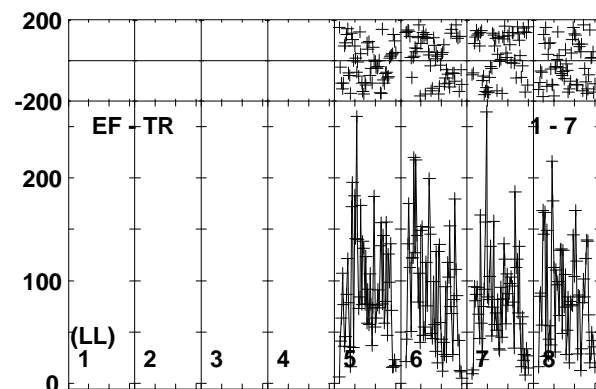
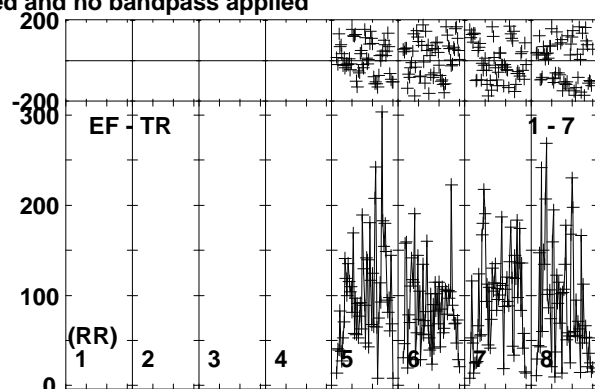
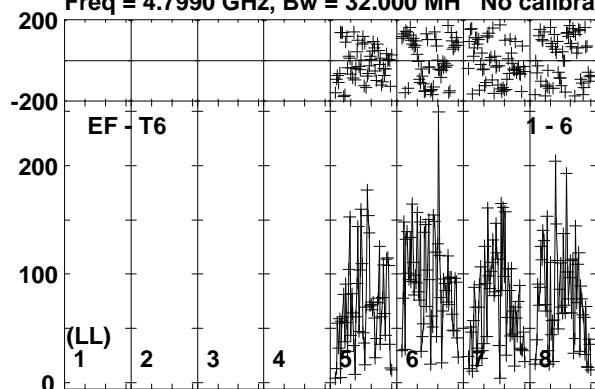

Lower frame: Micro Ampl Jy Top frame: Phas deg
Vector averaged cross-power spectrum Baseline: EF (01) - T6 (06)
Timerange: 00/09:18:29 to 00/09:21:59

Plot file version 157 created 03-OCT-2017 13:27:47

J1108+4330 EG096C.UVDATA.1

Freq = 4.7990 GHz, Bw = 32.000 MH No calibration applied and no bandpass applied

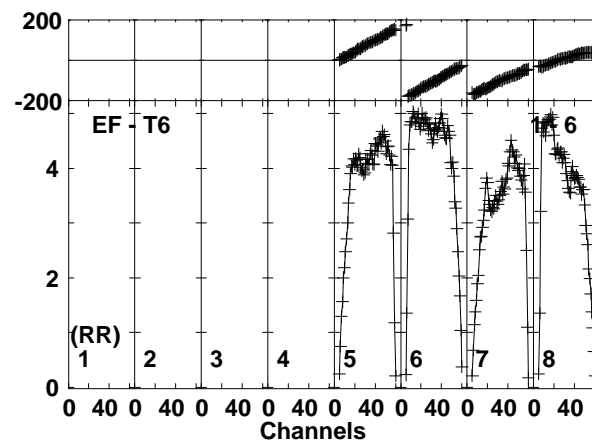
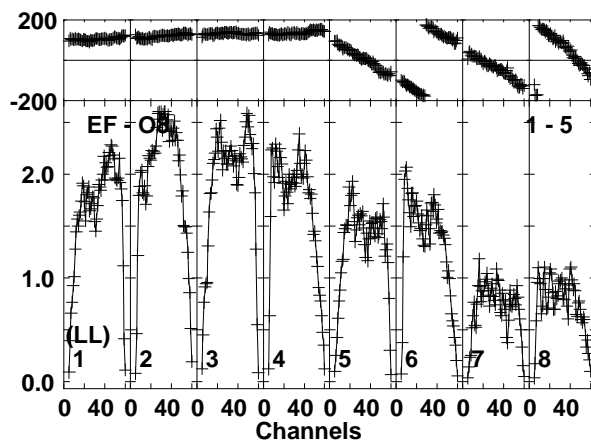
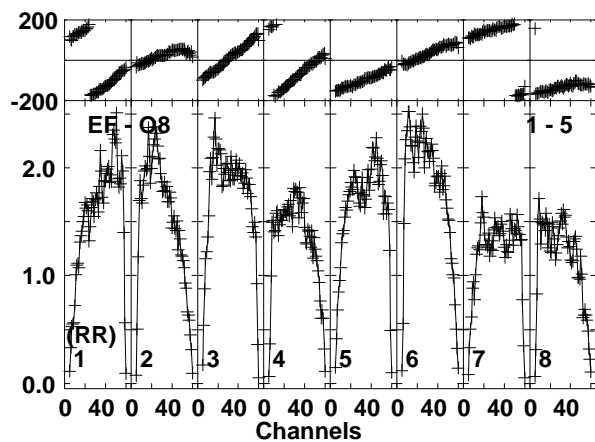
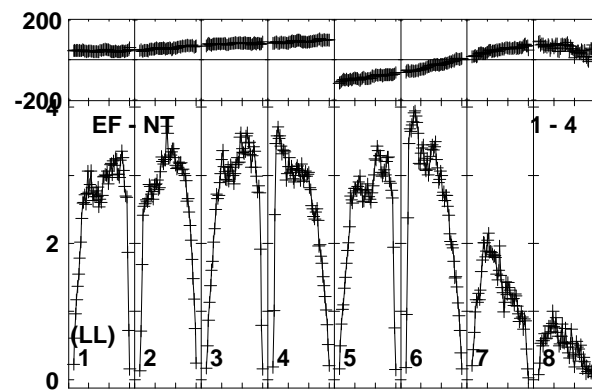
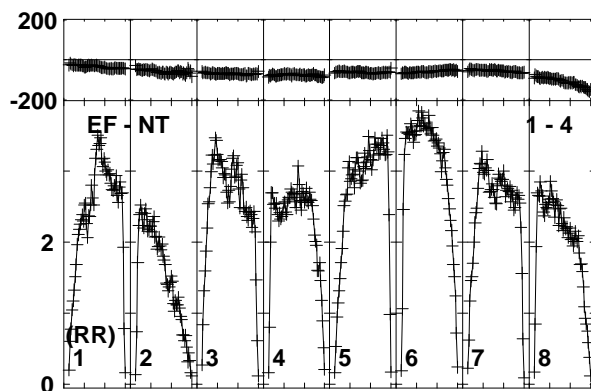
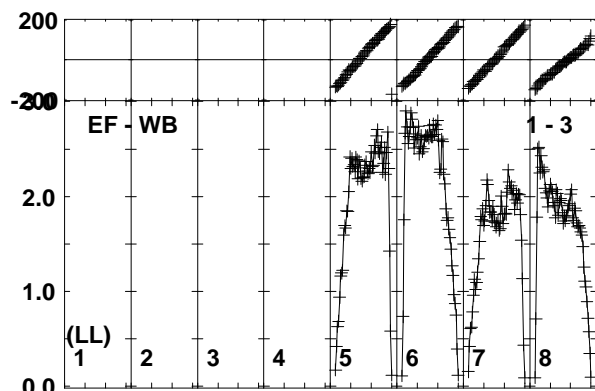
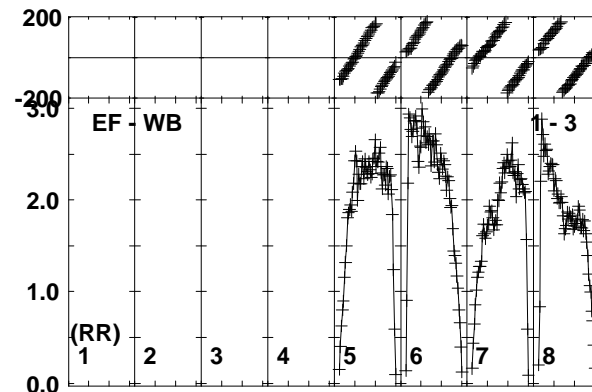
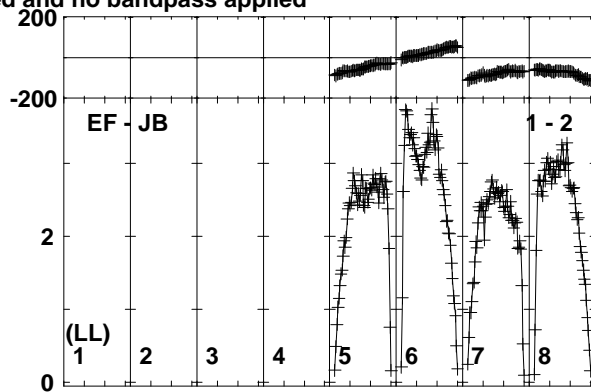
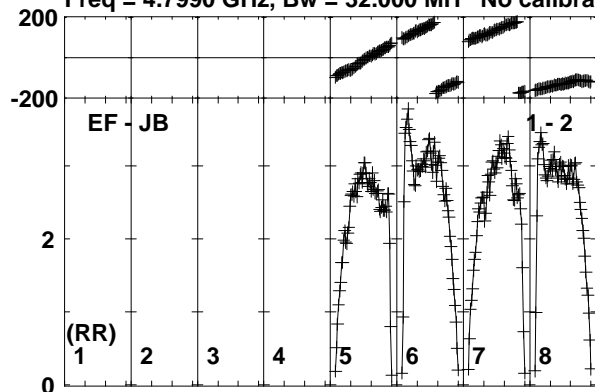

Lower frame: Milli Ampl Jy Top frame: Phas deg
Vector averaged cross-power spectrum Baseline: EF (01) - JB (02)
Timerange: 00/09:22:39 to 00/09:23:38

Plot file version 158 created 03-OCT-2017 13:27:48

J1108+4330 EG096C.UVDATA.1

Freq = 4.7990 GHz, Bw = 32.000 MH No calibration applied and no bandpass applied

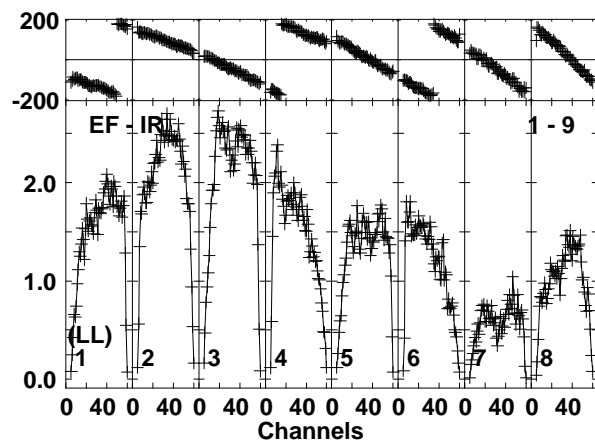
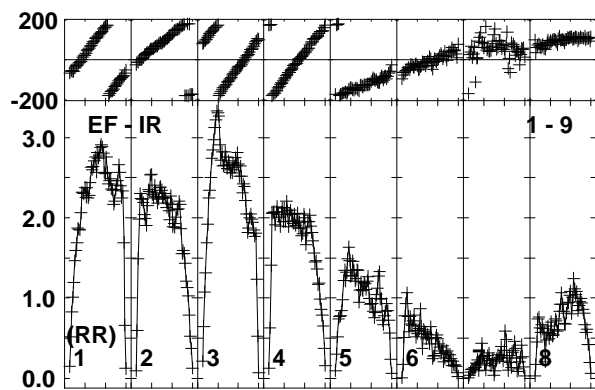
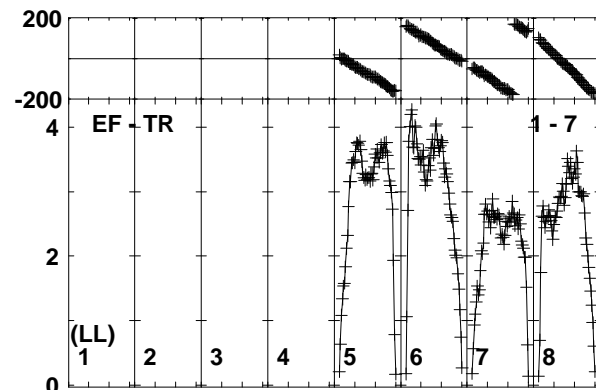
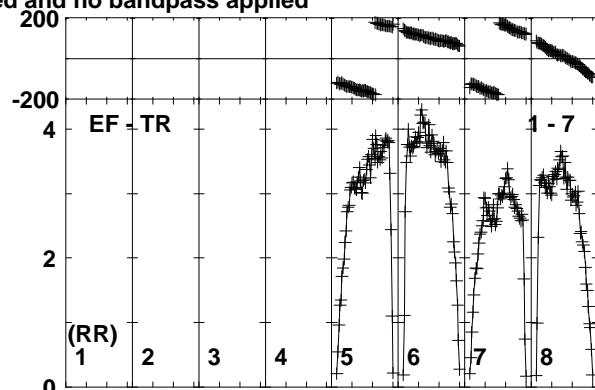
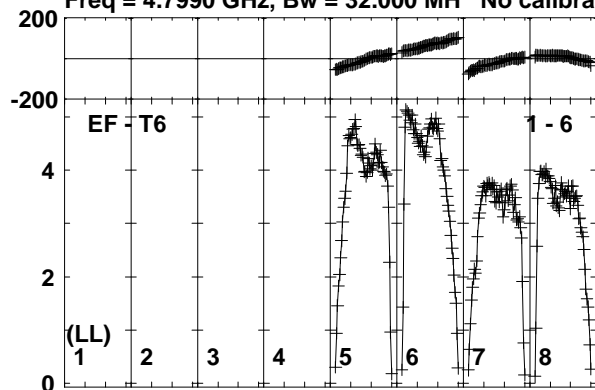

Lower frame: Milli Ampl Jy Top frame: Phas deg
Vector averaged cross-power spectrum Baseline: EF (01) - T6 (06)
Timerange: 00/09:22:39 to 00/09:23:38

Plot file version 159 created 03-OCT-2017 13:27:48

ARUMA EG096C.UVDATA.1

Freq = 4.7990 GHz, Bw = 32.000 MH No calibration applied and no bandpass applied

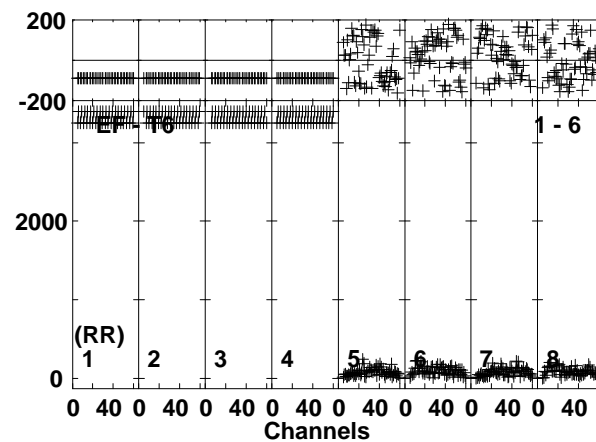
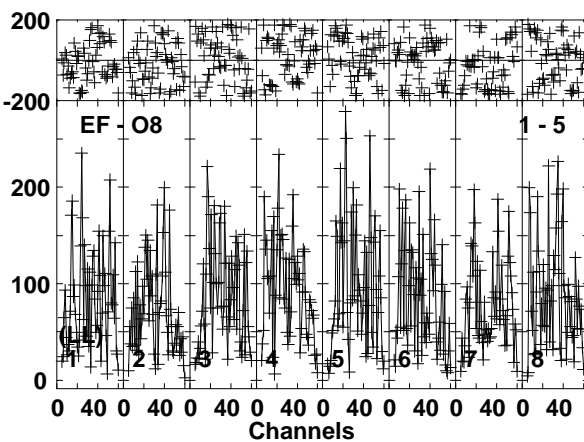
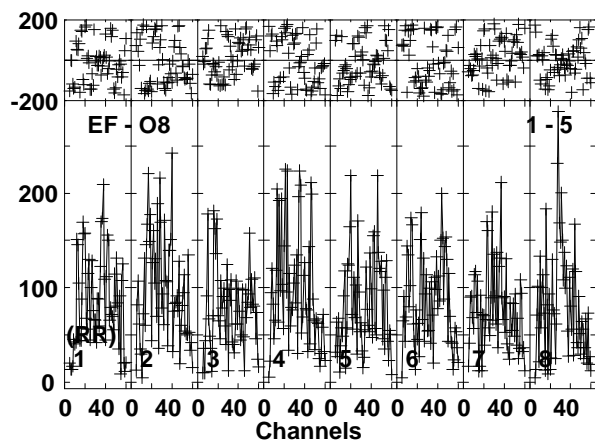
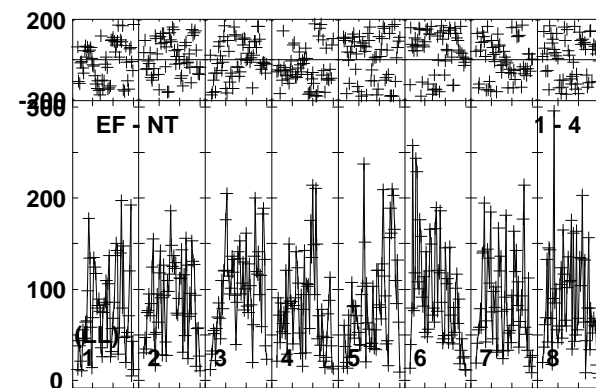
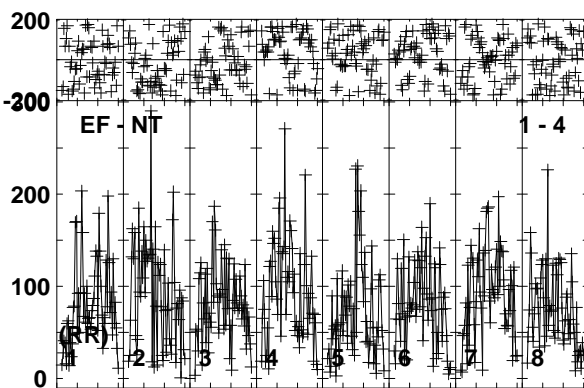
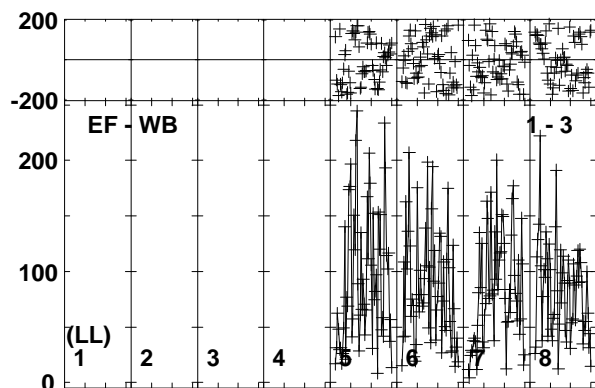
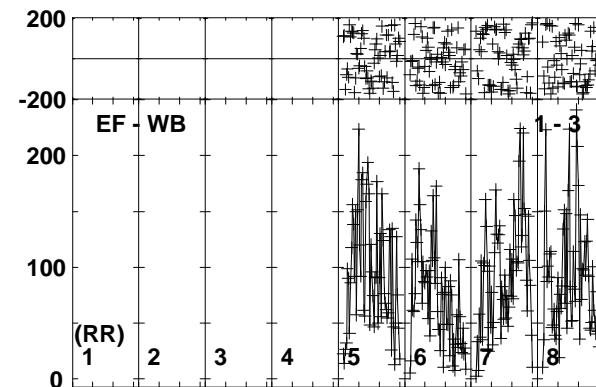
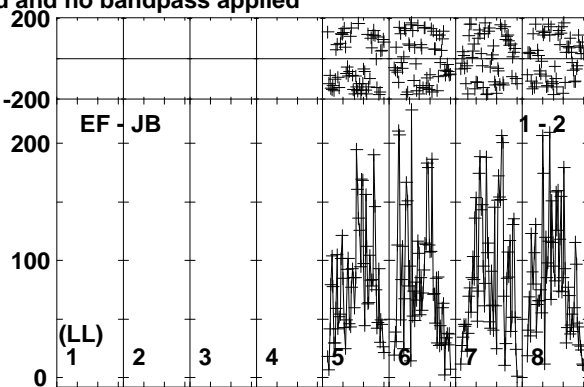
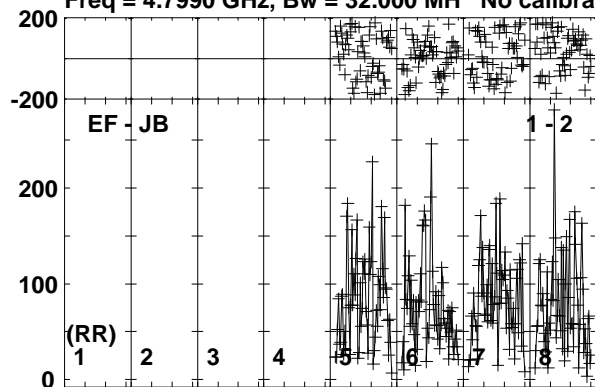

Lower frame: Micro Ampl Jy Top frame: Phas deg
Vector averaged cross-power spectrum Baseline: EF (01) - JB (02)
Timerange: 00/09:23:39 to 00/09:27:08

Plot file version 160 created 03-OCT-2017 13:27:48

ARUMA EG096C.UVDATA.1

Freq = 4.7990 GHz, Bw = 32.000 MH No calibration applied and no bandpass applied

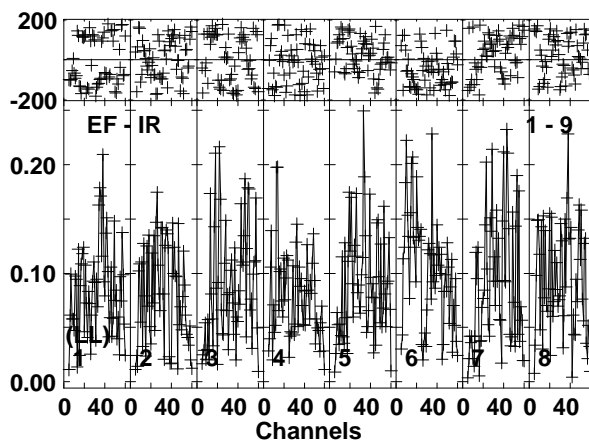
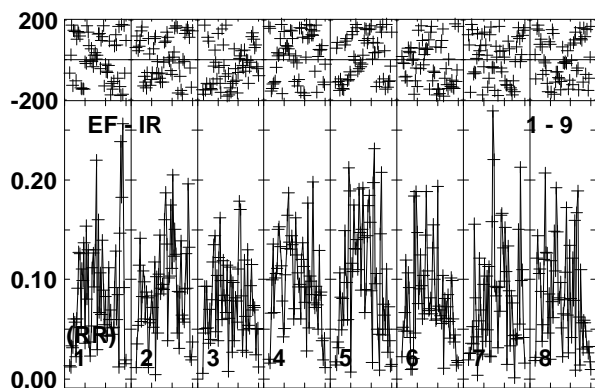
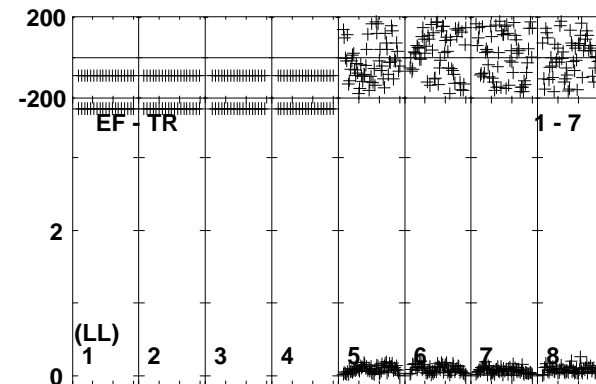
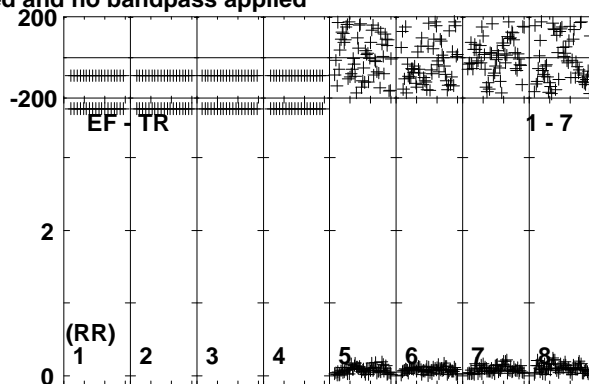
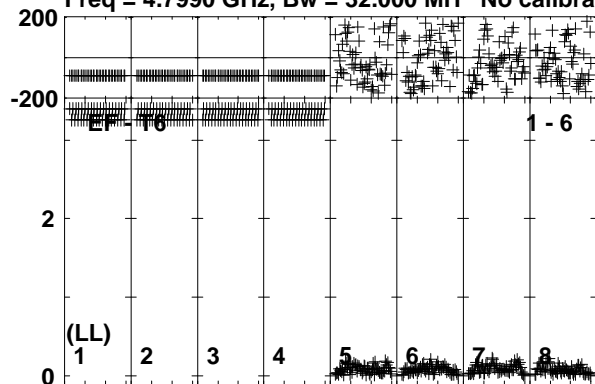

Lower frame: Milli Ampl Jy Top frame: Phas deg
Vector averaged cross-power spectrum Baseline: EF (01) - T6 (06)
Timerange: 00/09:23:39 to 00/09:27:08

Plot file version 161 created 03-OCT-2017 13:27:48

J1108+4330 EG096C.UVDATA.1

Freq = 4.7990 GHz, Bw = 32.000 MH No calibration applied and no bandpass applied

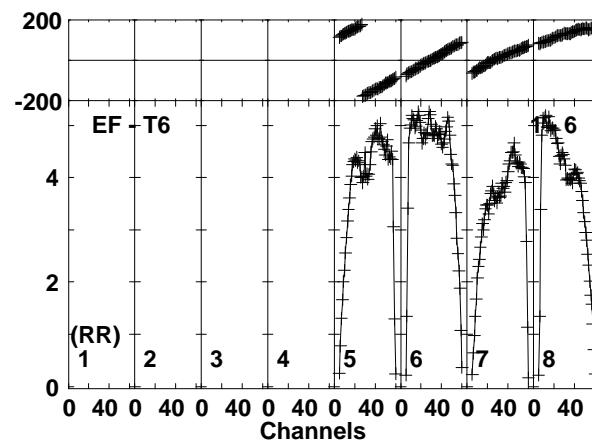
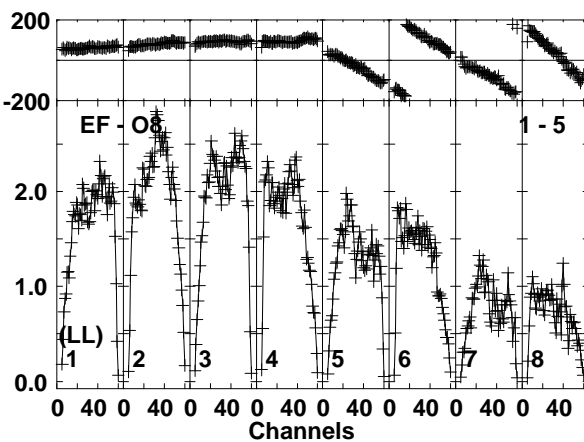
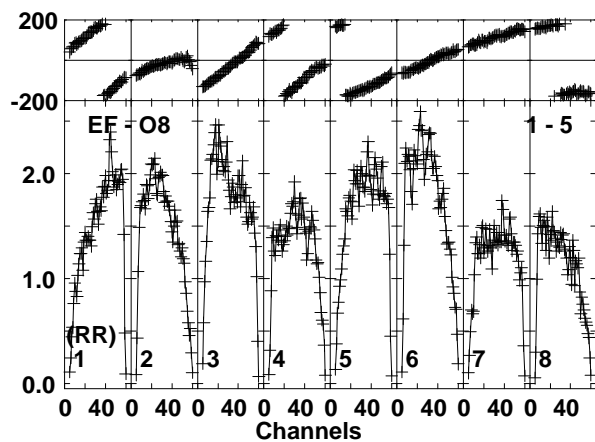
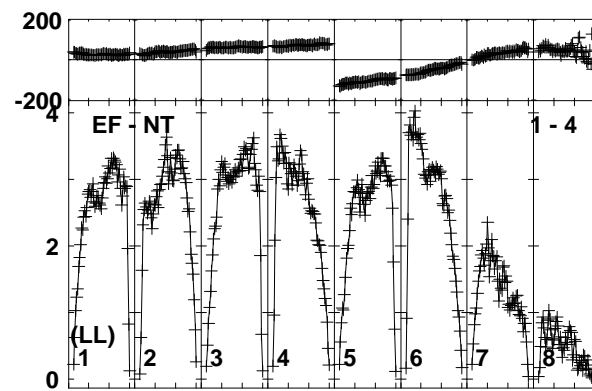
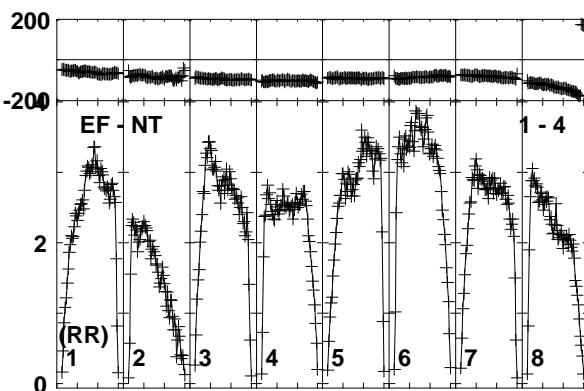
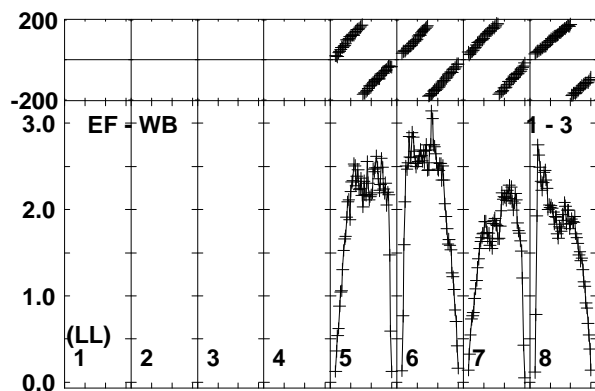
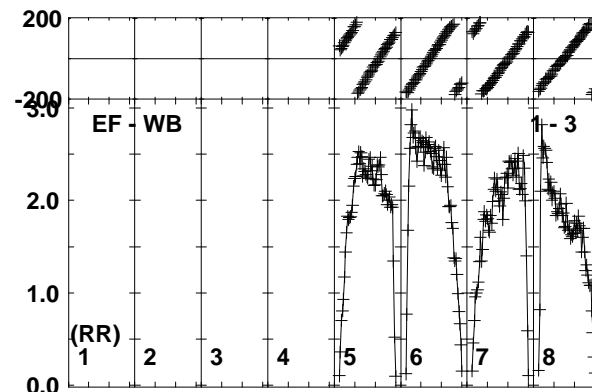
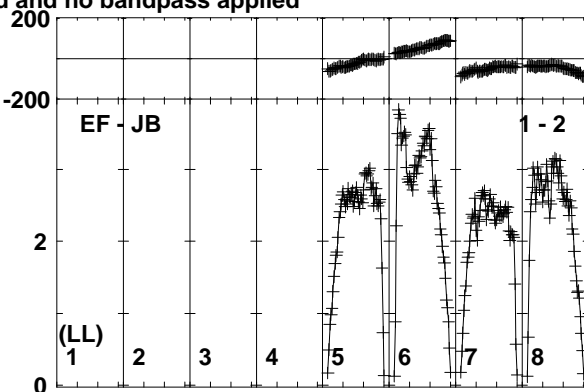
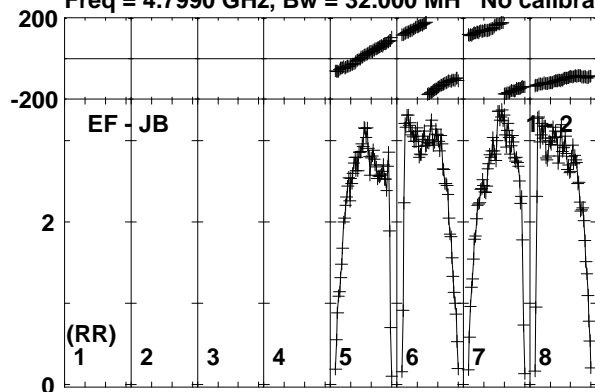

Lower frame: Milli Ampl Jy Top frame: Phas deg
Vector averaged cross-power spectrum Baseline: EF (01) - JB (02)
Timerange: 00/09:27:09 to 00/09:28:38

Plot file version 162 created 03-OCT-2017 13:27:48

J1108+4330 EG096C.UVDATA.1

Freq = 4.7990 GHz, Bw = 32.000 MH No calibration applied and no bandpass applied

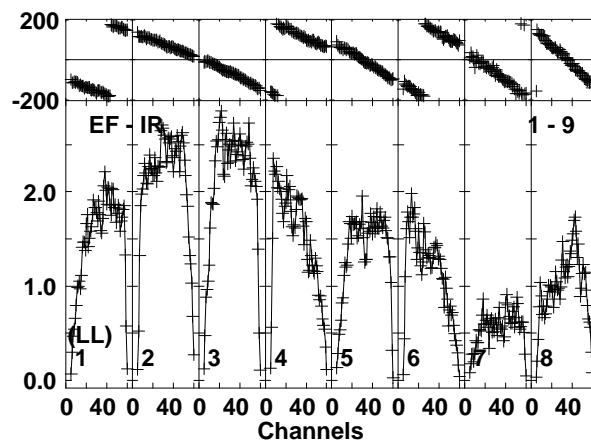
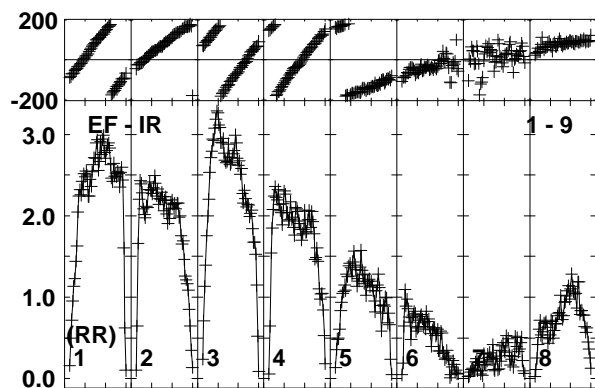
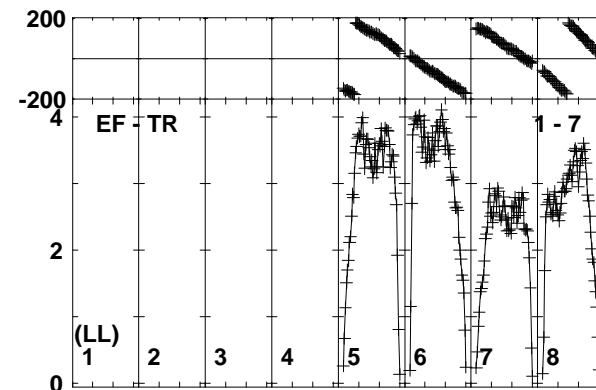
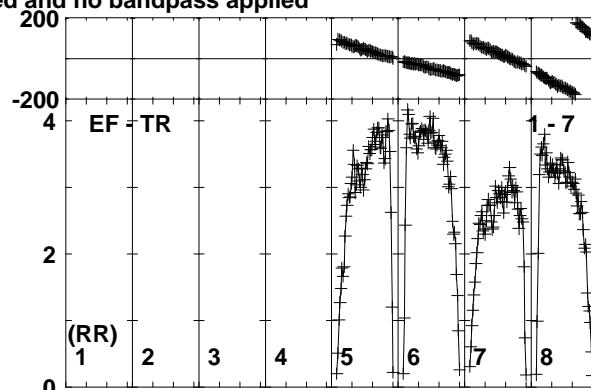
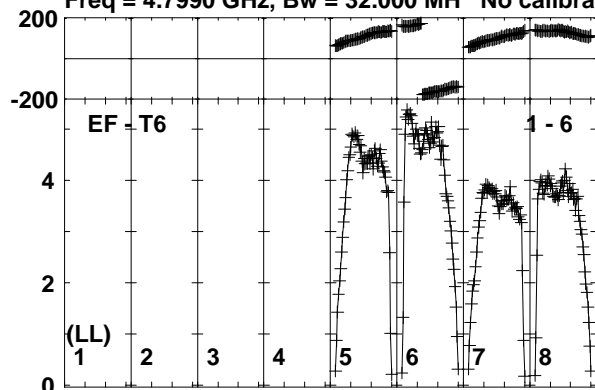

Lower frame: Milli Ampl Jy Top frame: Phas deg
Vector averaged cross-power spectrum Baseline: EF (01) - T6 (06)
Timerange: 00/09:27:09 to 00/09:28:38

Plot file version 163 created 03-OCT-2017 13:27:49

ARUMA EG096C.UVDATA.1

Freq = 4.7990 GHz, Bw = 32.000 MH No calibration applied and no bandpass applied

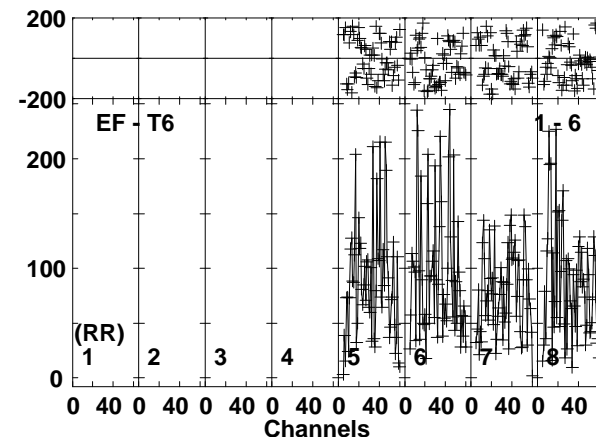
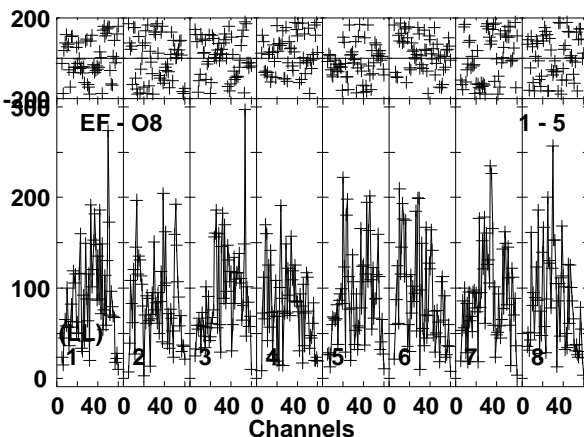
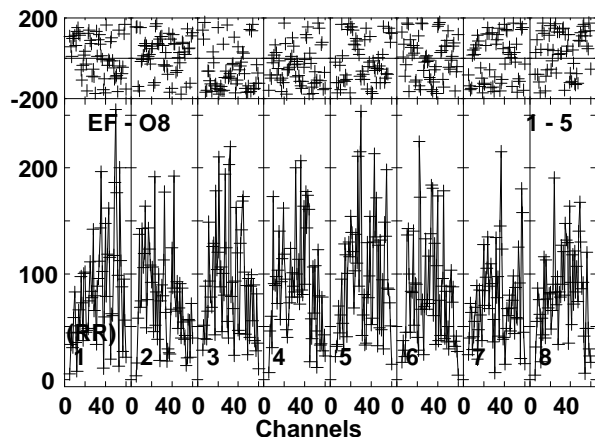
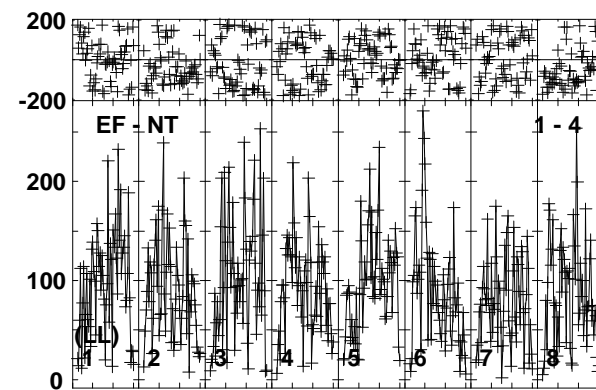
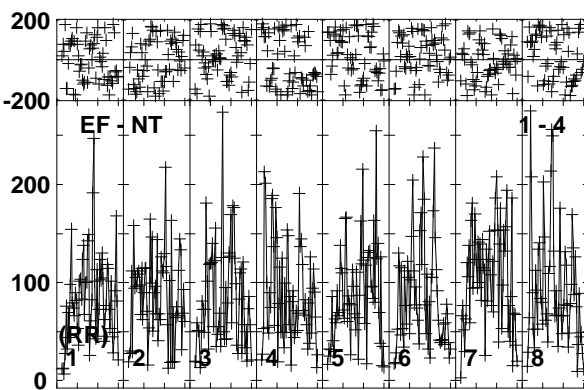
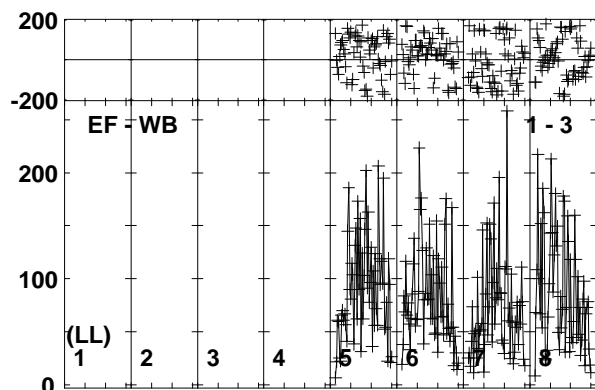
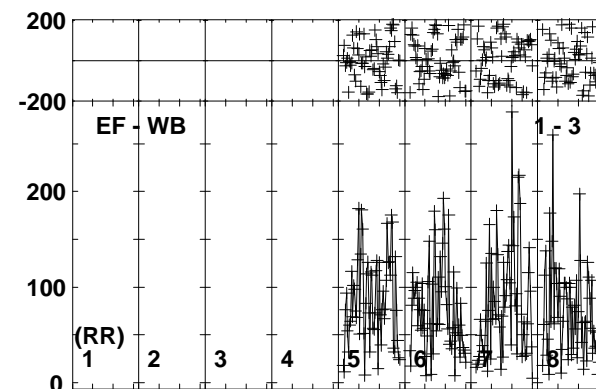
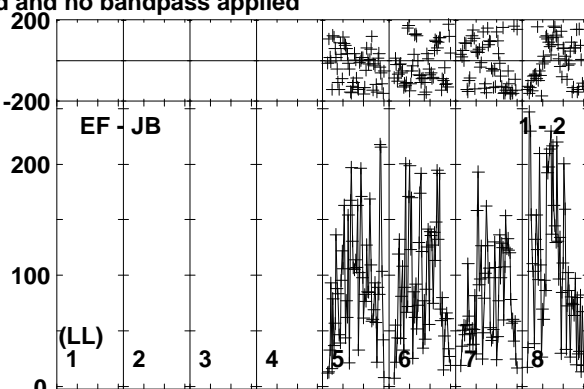
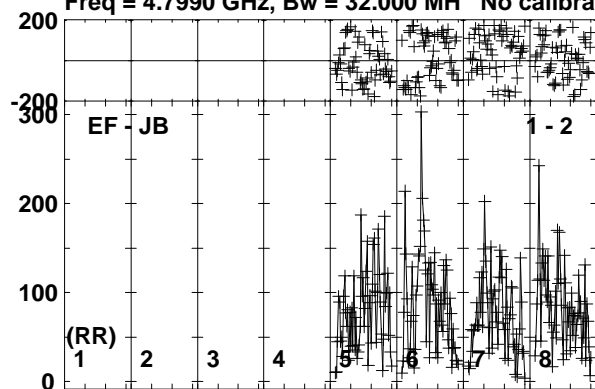

Lower frame: Micro Ampl Jy Top frame: Phas deg
Vector averaged cross-power spectrum Baseline: EF (01) - JB (02)
Timerange: 00/09:28:40 to 00/09:32:09

Plot file version 164 created 03-OCT-2017 13:27:49

ARUMA EG096C.UVDATA.1

Freq = 4.7990 GHz, Bw = 32.000 MH No calibration applied and no bandpass applied

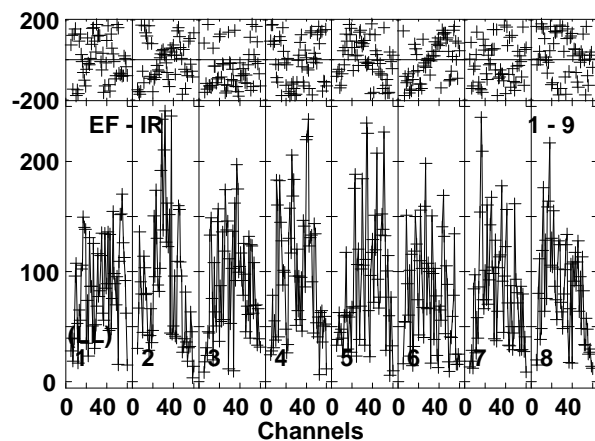
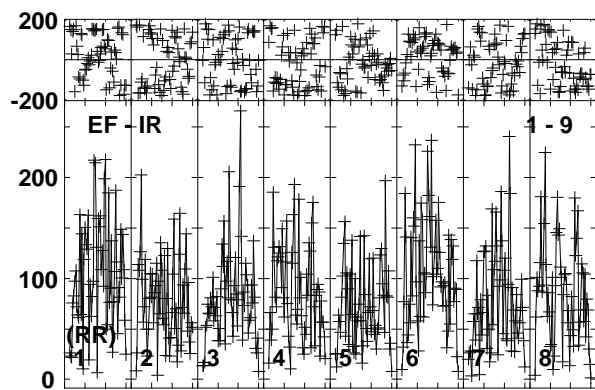
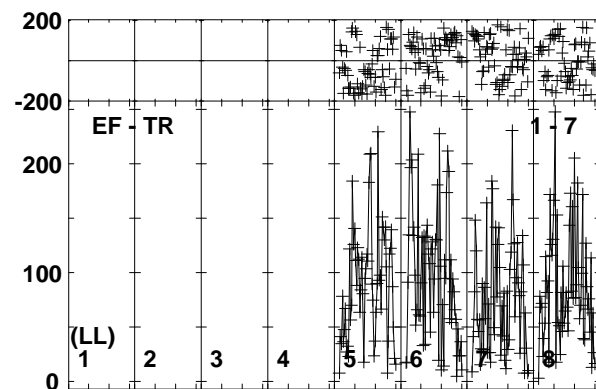
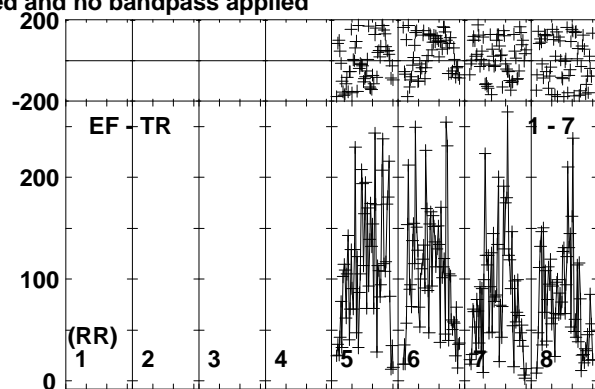
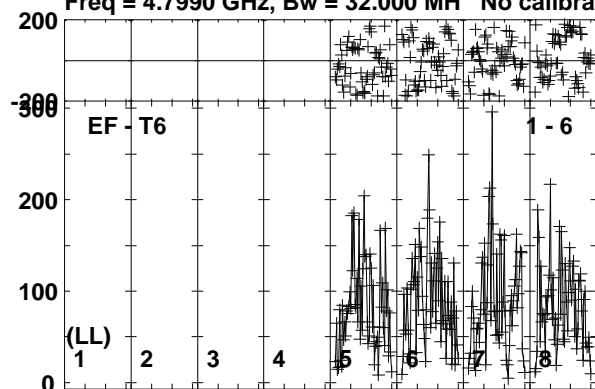

Lower frame: Micro Ampl Jy Top frame: Phas deg
Vector averaged cross-power spectrum Baseline: EF (01) - T6 (06)
Timerange: 00/09:28:40 to 00/09:32:09

Plot file version 165 created 03-OCT-2017 13:27:49

J1108+4330 EG096C.UVDATA.1

Freq = 4.7990 GHz, Bw = 32.000 MH No calibration applied and no bandpass applied

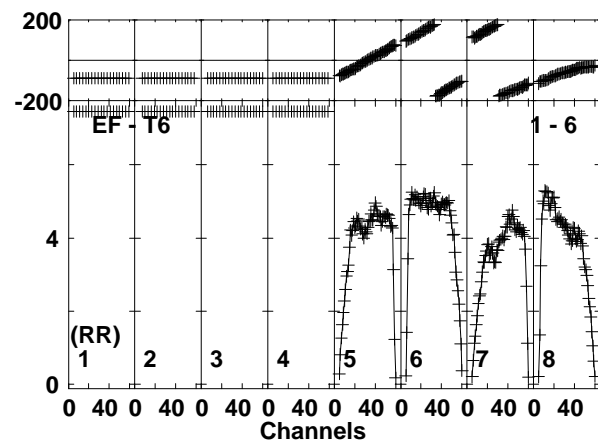
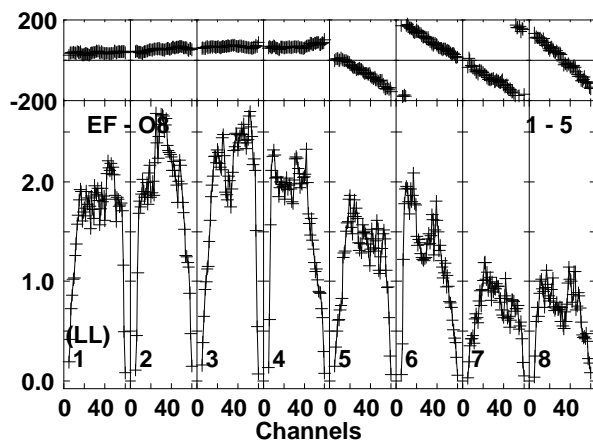
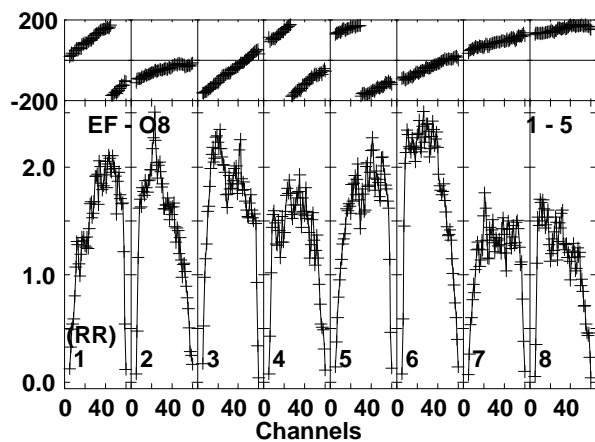
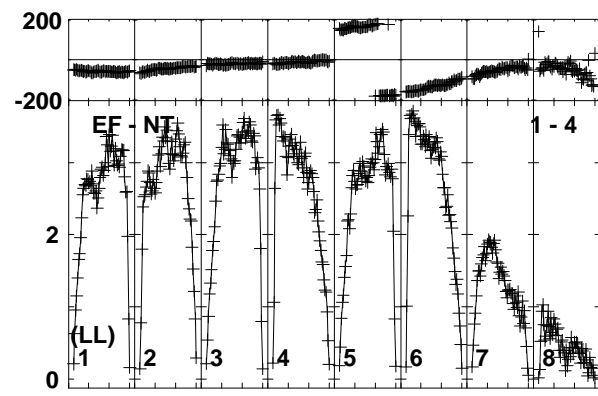
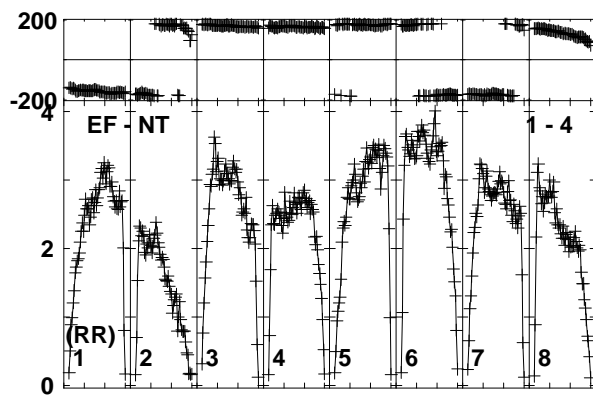
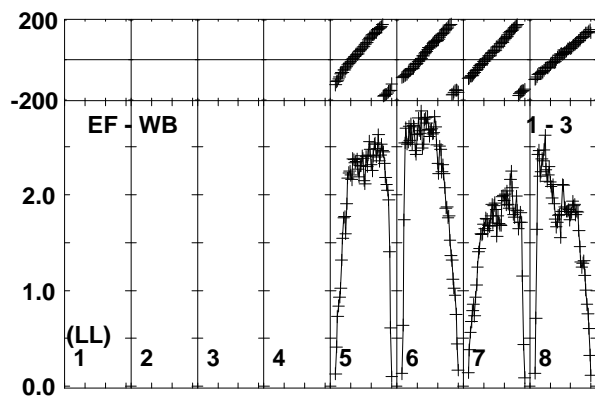
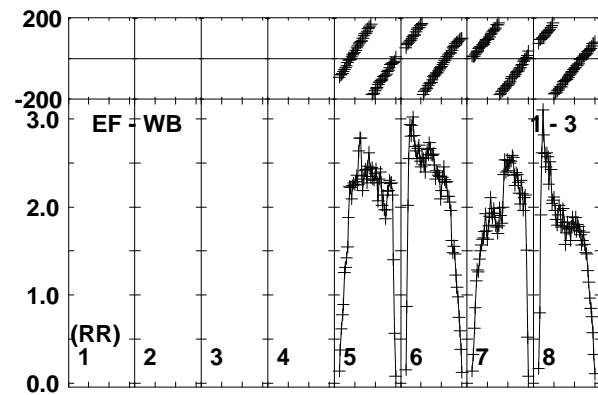
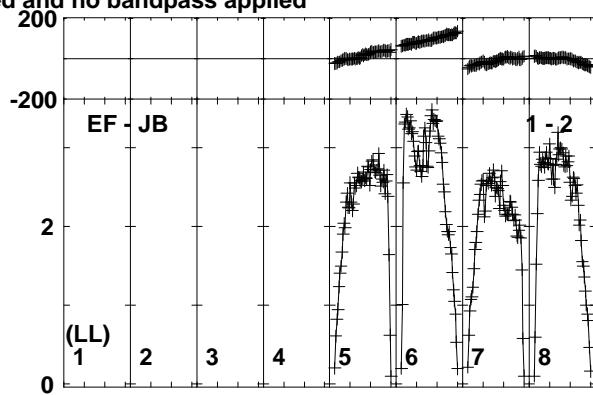
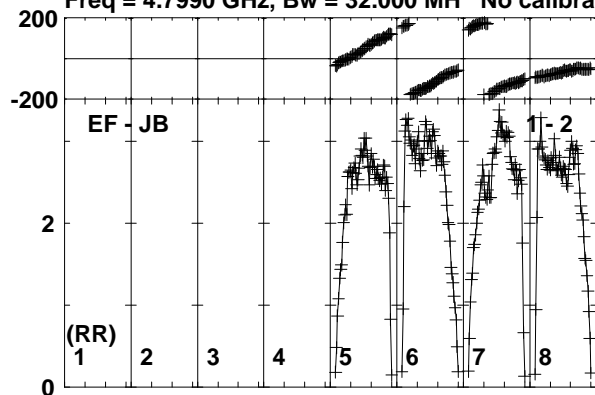

Lower frame: Milli Ampl Jy Top frame: Phas deg
Vector averaged cross-power spectrum Baseline: EF (01) - JB (02)
Timerange: 00/09:32:49 to 00/09:33:48

Plot file version 166 created 03-OCT-2017 13:27:49

J1108+4330 EG096C.UVDATA.1

Freq = 4.7990 GHz, Bw = 32.000 MH No calibration applied and no bandpass applied

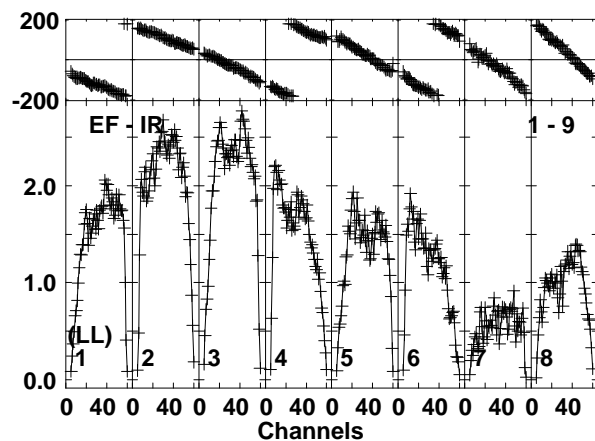
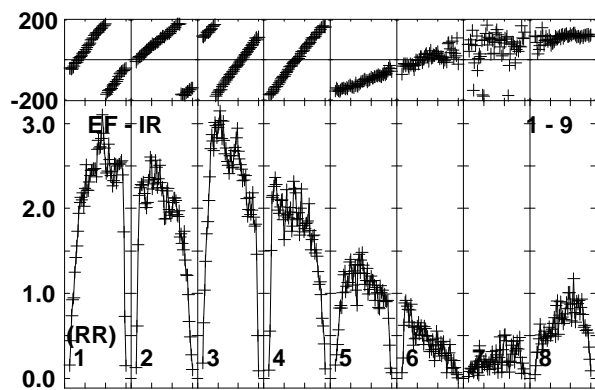
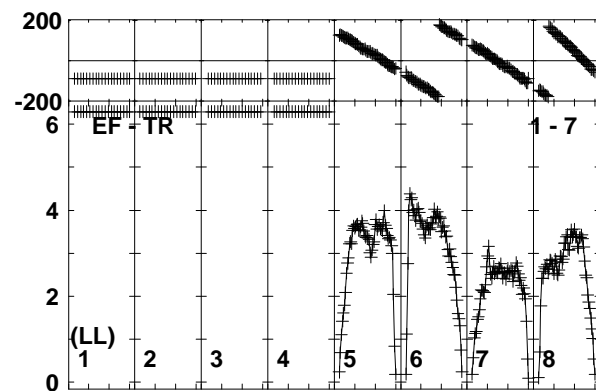
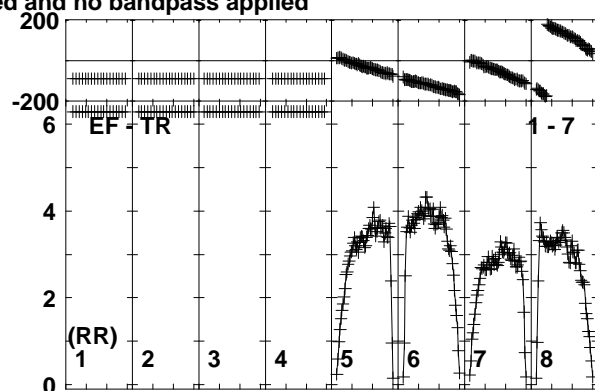
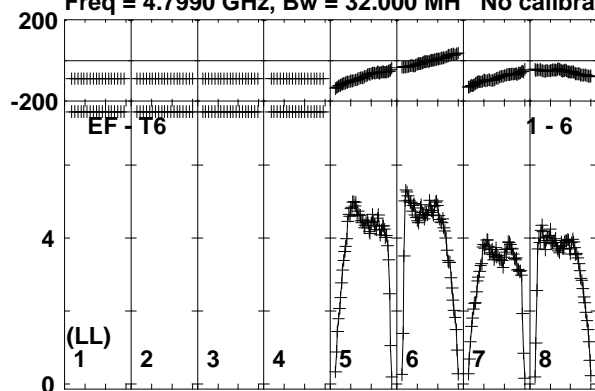

Lower frame: Milli Ampl Jy Top frame: Phas deg
Vector averaged cross-power spectrum Baseline: EF (01) - T6 (06)
Timerange: 00/09:32:49 to 00/09:33:48

Plot file version 167 created 03-OCT-2017 13:27:50

ARUMA EG096C.UVDATA.1

Freq = 4.7990 GHz, Bw = 32.000 MH No calibration applied and no bandpass applied

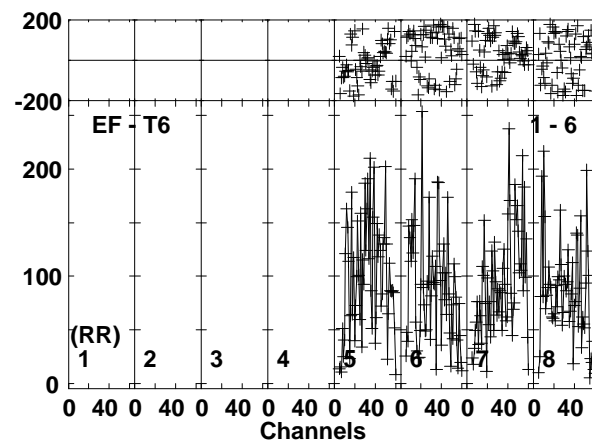
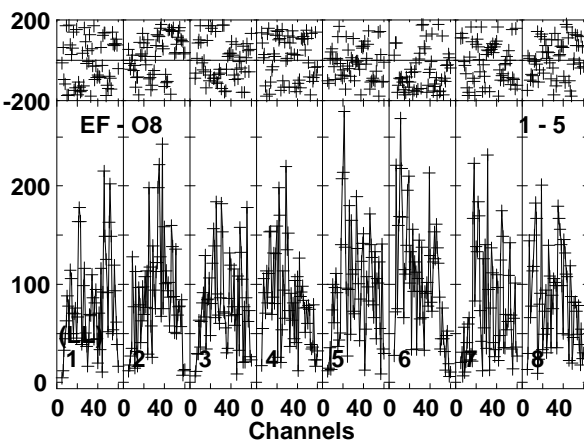
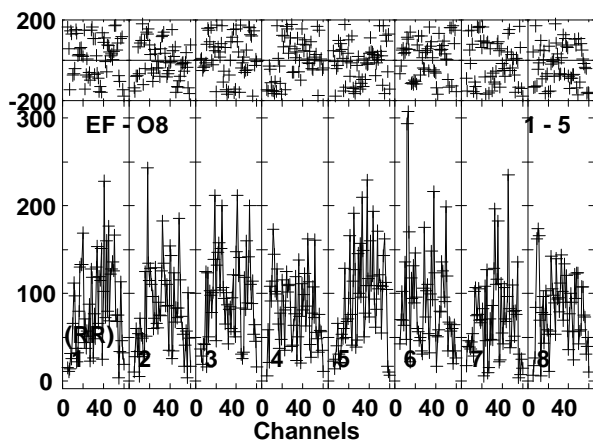
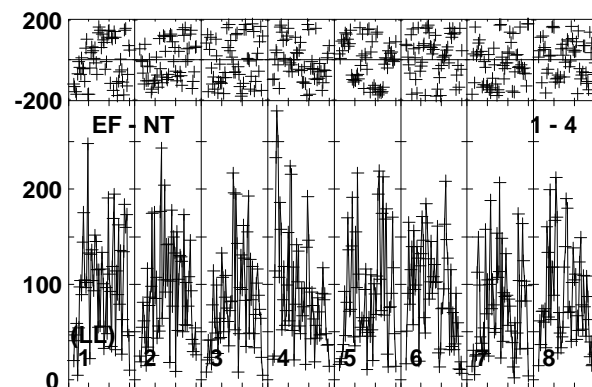
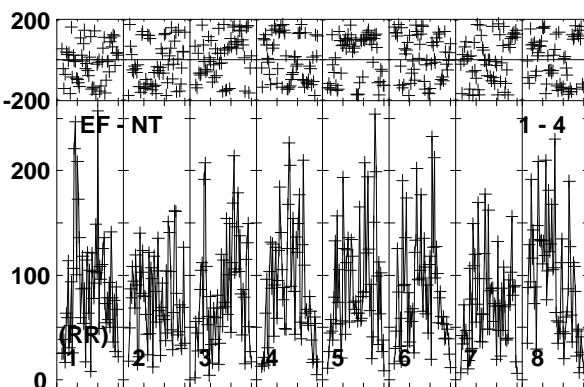
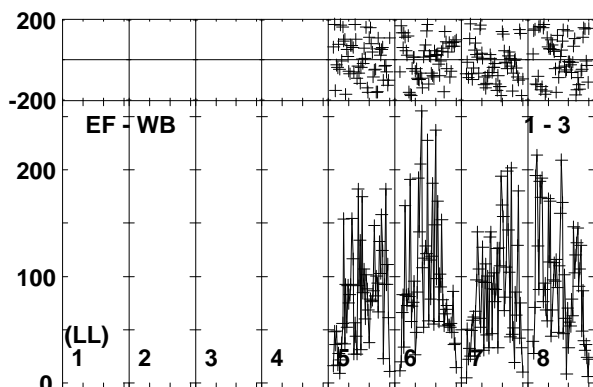
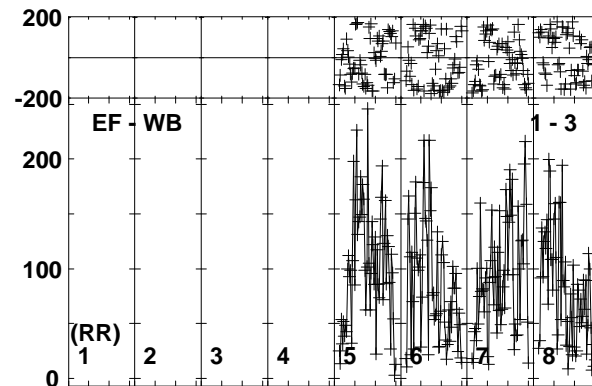
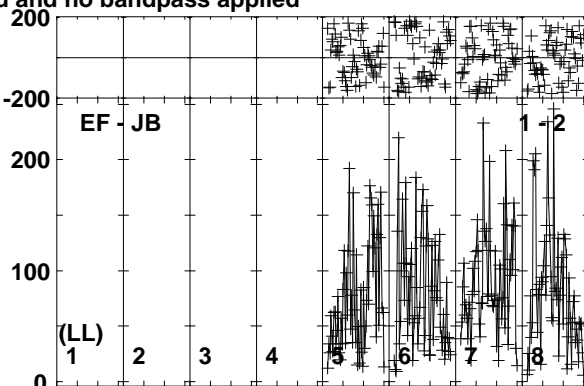
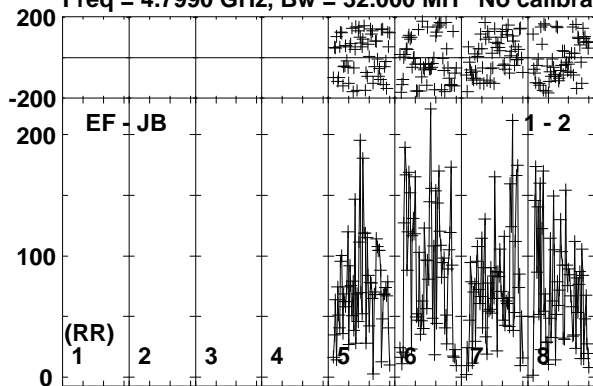

Lower frame: Micro Ampl Jy Top frame: Phas deg
Vector averaged cross-power spectrum Baseline: EF (01) - JB (02)
Timerange: 00/09:33:50 to 00/09:37:19

Plot file version 168 created 03-OCT-2017 13:27:50

ARUMA EG096C.UVDATA.1

Freq = 4.7990 GHz, Bw = 32.000 MH No calibration applied and no bandpass applied

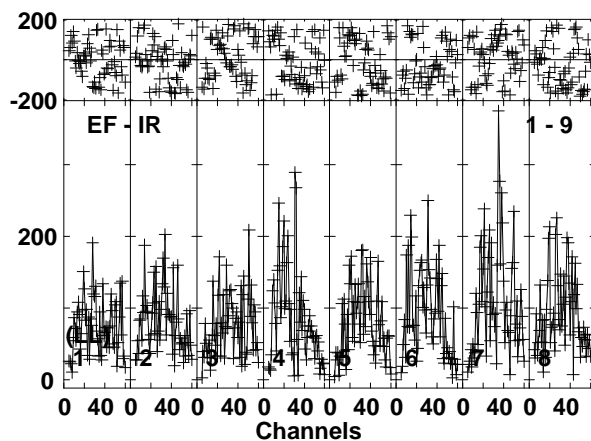
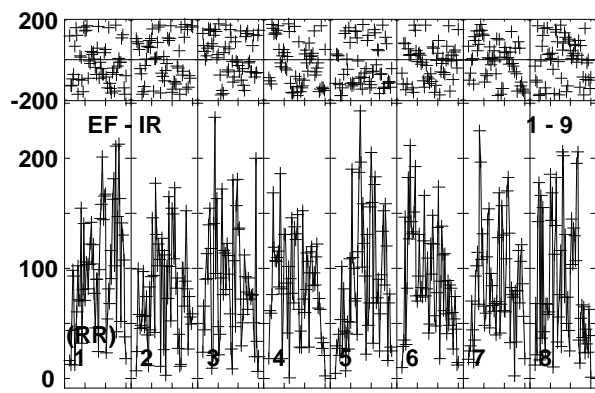
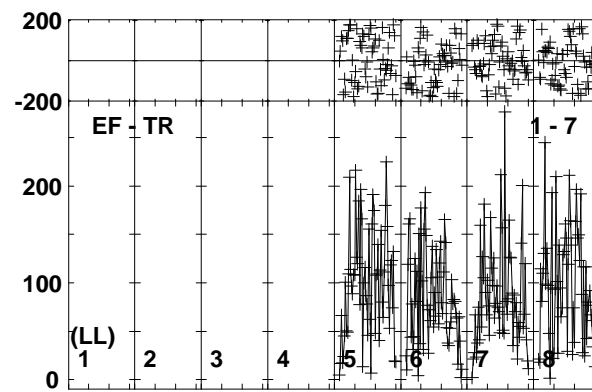
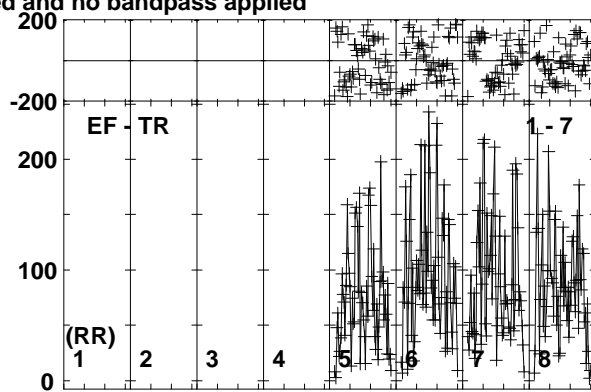
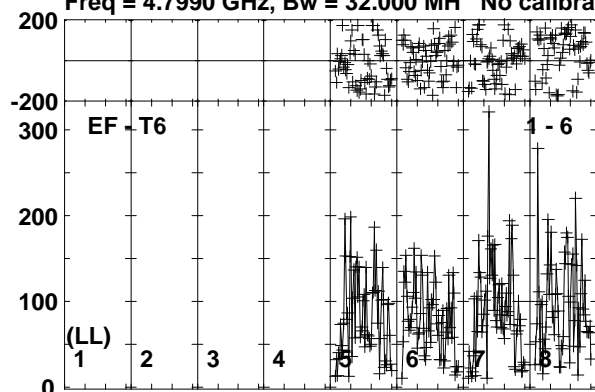

Channels

Lower frame: Micro Ampl Jy Top frame: Phas deg
Vector averaged cross-power spectrum Baseline: EF (01) - T6 (06)
Timerange: 00/09:33:50 to 00/09:37:19

Plot file version 169 created 03-OCT-2017 13:27:50

J1108+4330 EG096C.UVDATA.1

Freq = 4.7990 GHz, Bw = 32.000 MH No calibration applied and no bandpass applied

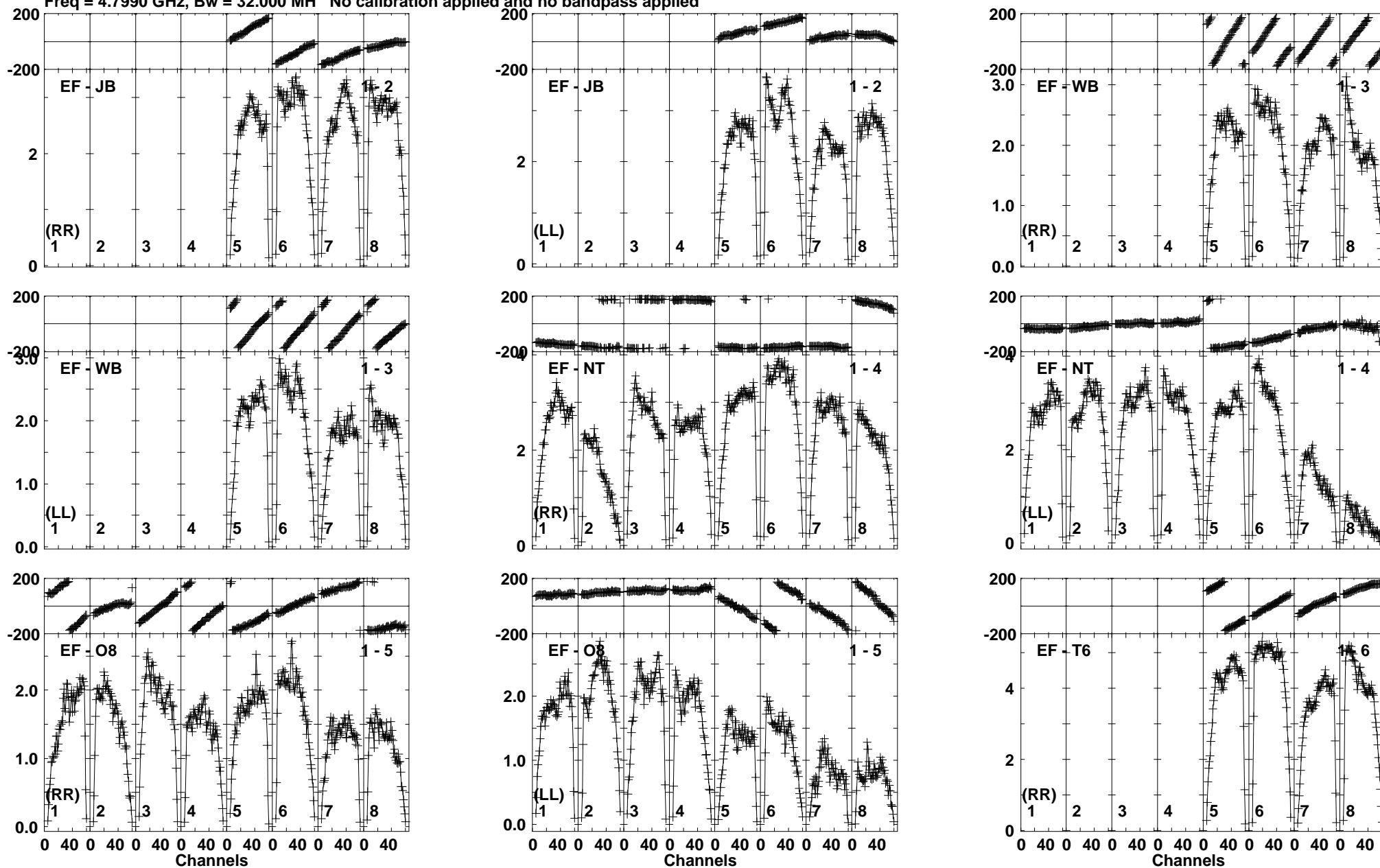

Lower frame: Milli Ampl Jy Top frame: Phas deg
Vector averaged cross-power spectrum Baseline: EF (01) - JB (02)
Timerange: 00/09:37:20 to 00/09:38:49

Plot file version 170 created 03-OCT-2017 13:27:50

J1108+4330 EG096C.UVDATA.1

Freq = 4.7990 GHz, Bw = 32.000 MH No calibration applied and no bandpass applied

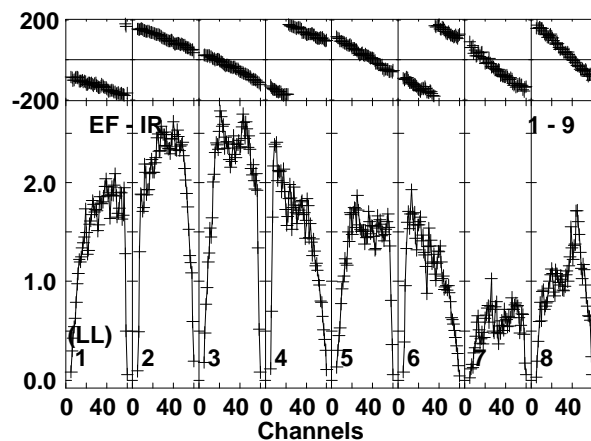
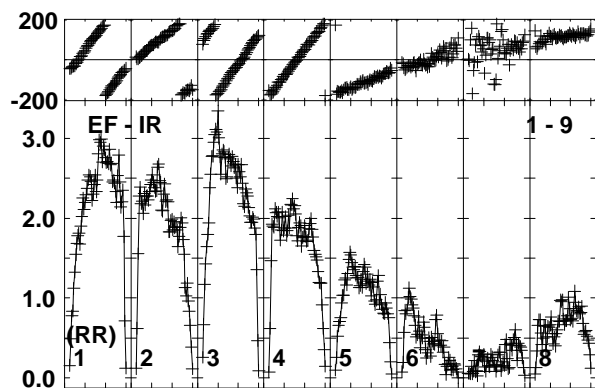
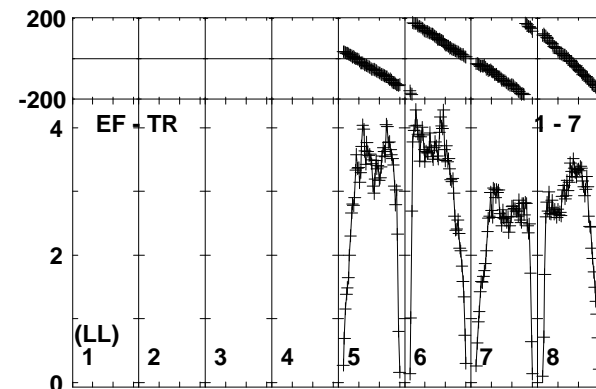
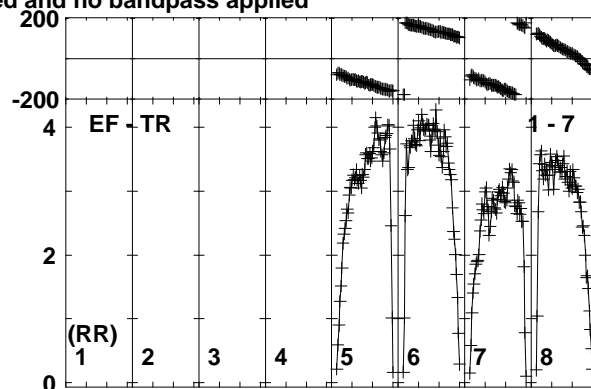
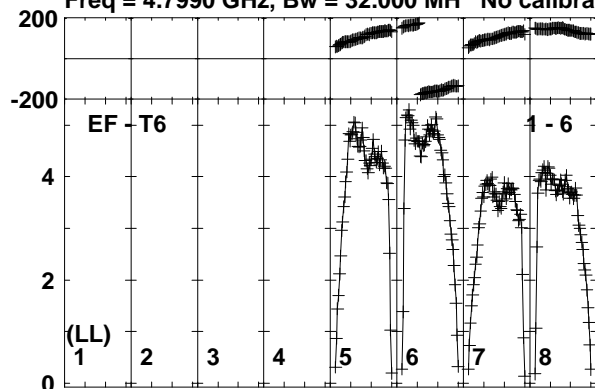

Lower frame: Milli Ampl Jy Top frame: Phas deg
Vector averaged cross-power spectrum Baseline: EF (01) - T6 (06)
Timerange: 00/09:37:20 to 00/09:38:49

Plot file version 171 created 03-OCT-2017 13:27:50

ARUMA EG096C.UVDATA.1

Freq = 4.7990 GHz, Bw = 32.000 MH No calibration applied and no bandpass applied

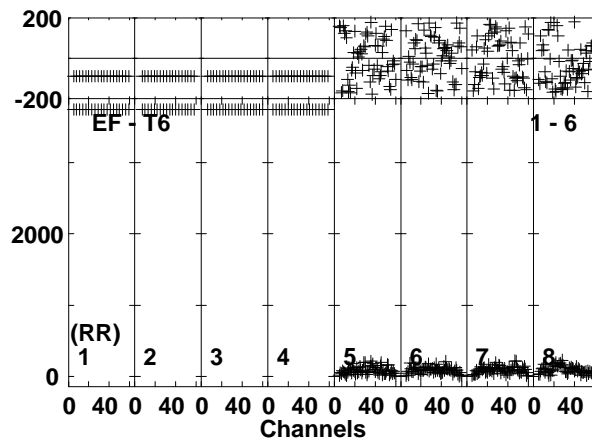
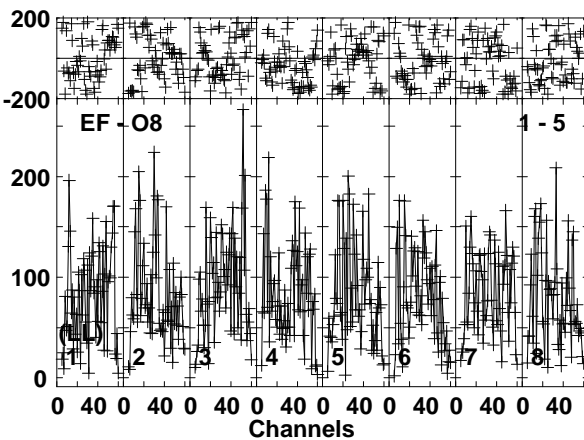
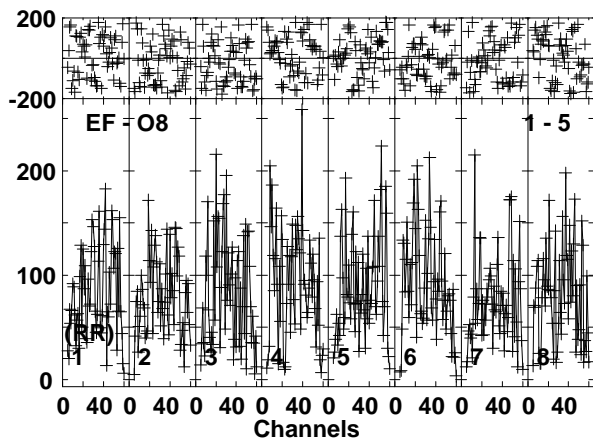
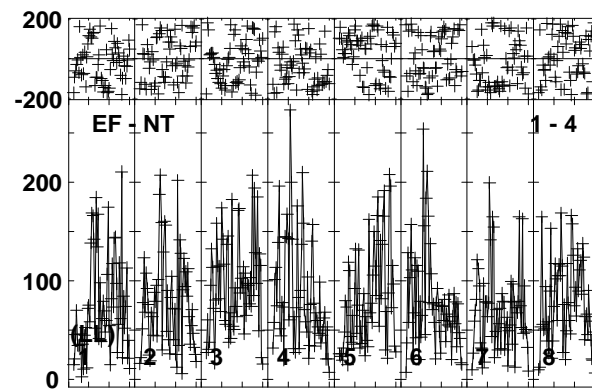
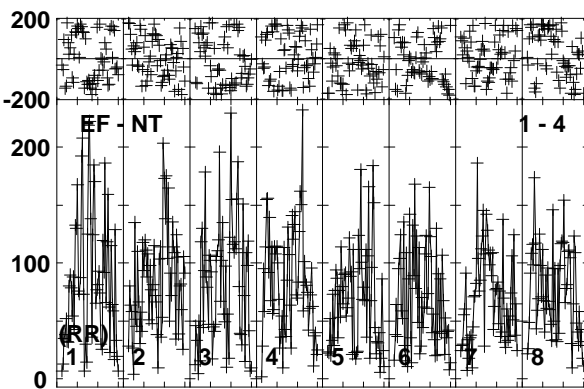
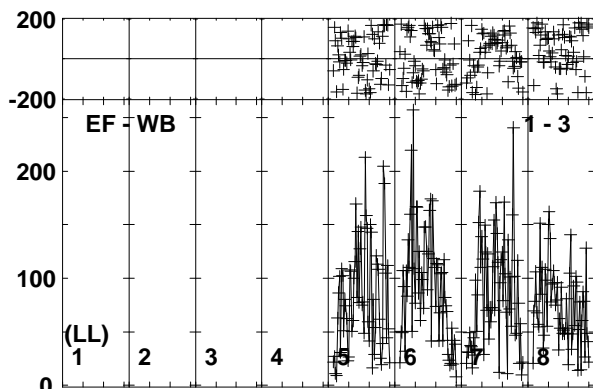
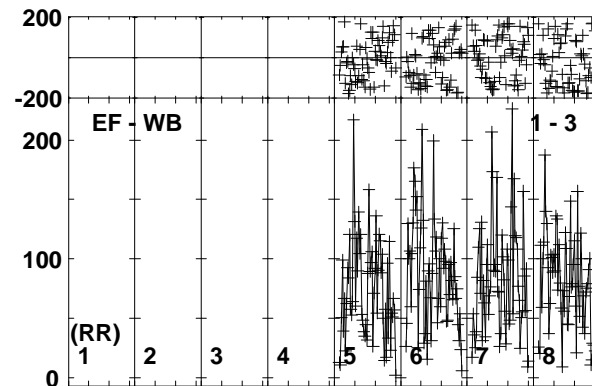
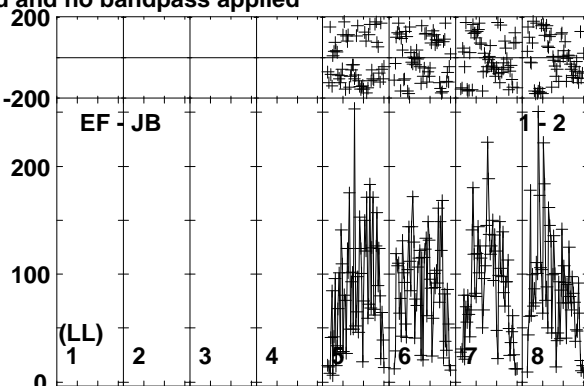
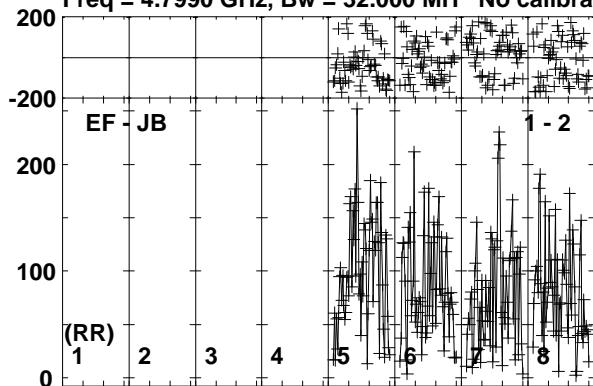

Lower frame: Micro Ampl Jy Top frame: Phas deg
Vector averaged cross-power spectrum Baseline: EF (01) - JB (02)
Timerange: 00/09:38:49 to 00/09:42:19

Plot file version 172 created 03-OCT-2017 13:27:51

ARUMA EG096C.UVDATA.1

Freq = 4.7990 GHz, Bw = 32.000 MH No calibration applied and no bandpass applied

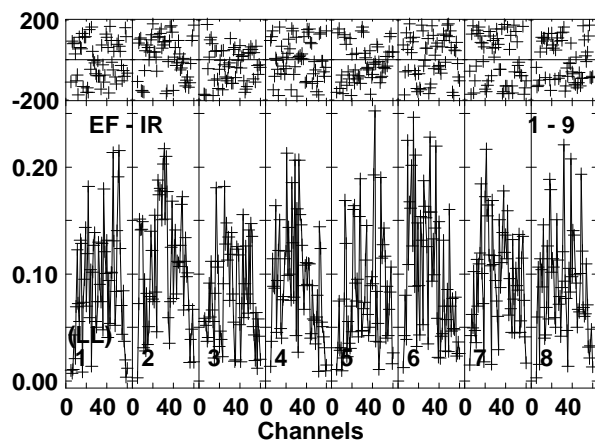
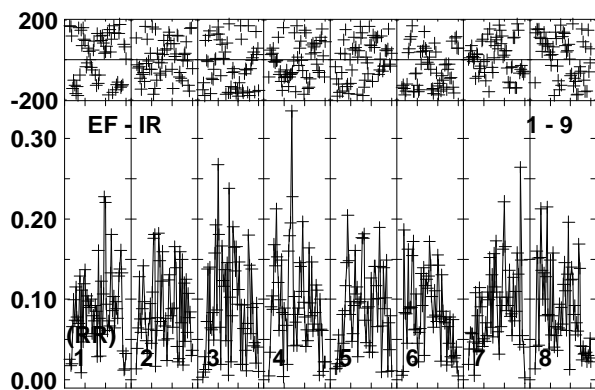
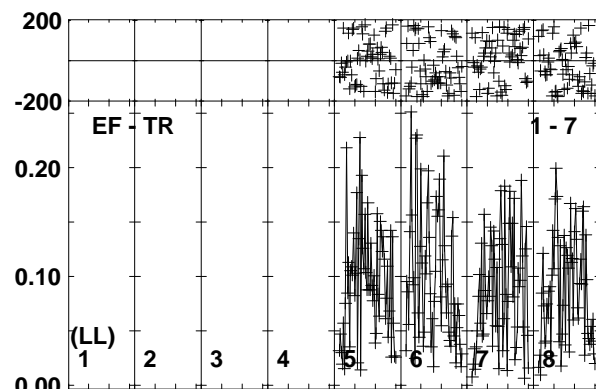
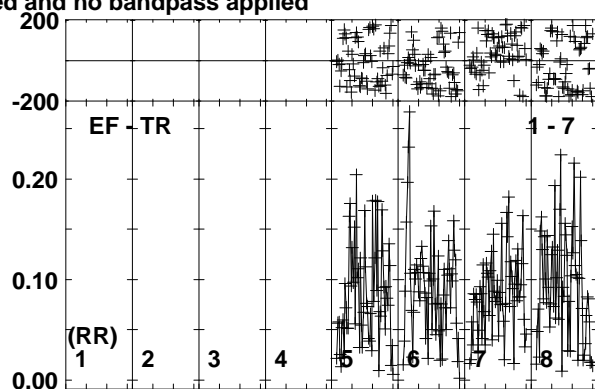
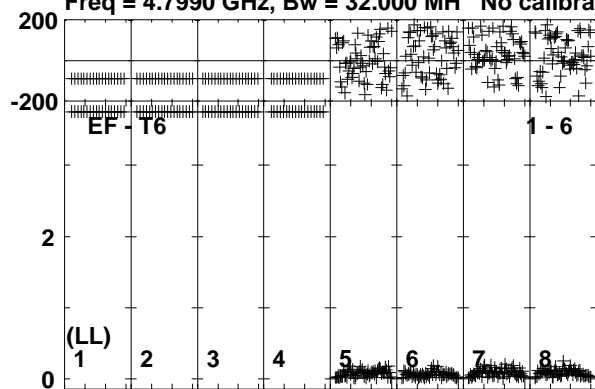

Lower frame: Milli Ampl Jy Top frame: Phas deg
Vector averaged cross-power spectrum Baseline: EF (01) - T6 (06)
Timerange: 00/09:38:49 to 00/09:42:19

Plot file version 173 created 03-OCT-2017 13:27:51

J1108+4330 EG096C.UVDATA.1

Freq = 4.7990 GHz, Bw = 32.000 MH No calibration applied and no bandpass applied

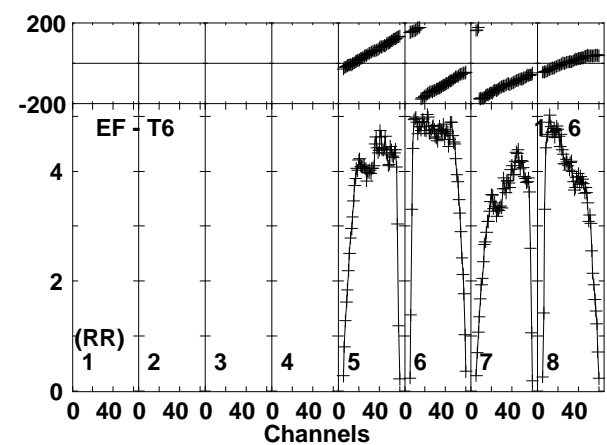
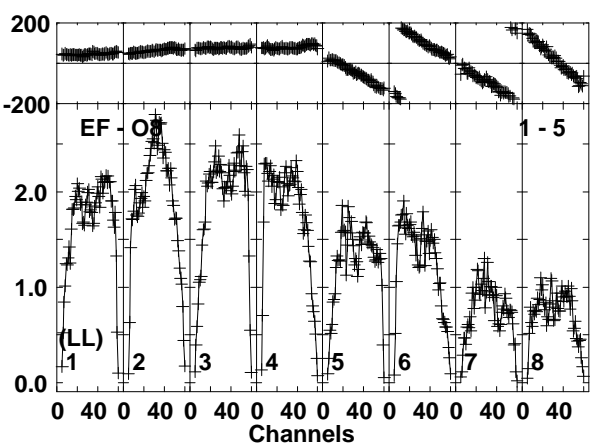
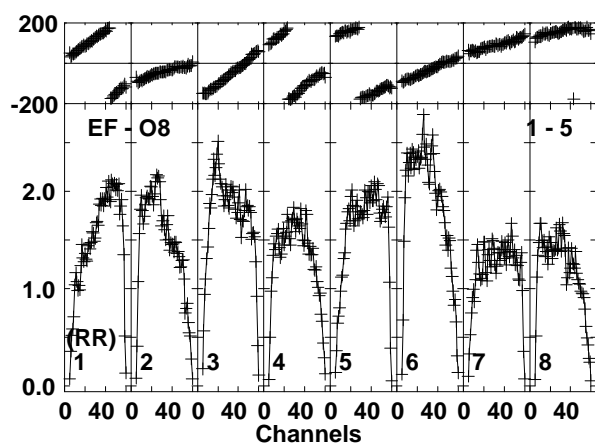
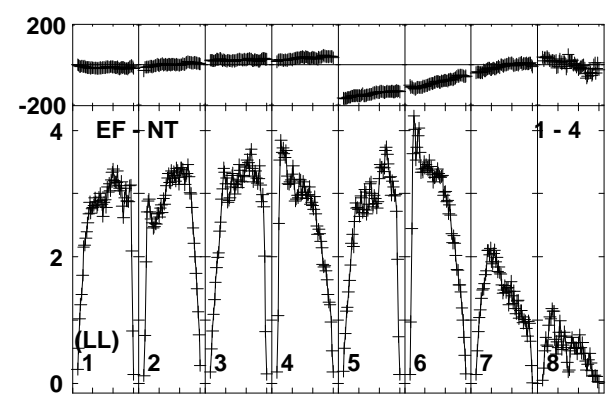
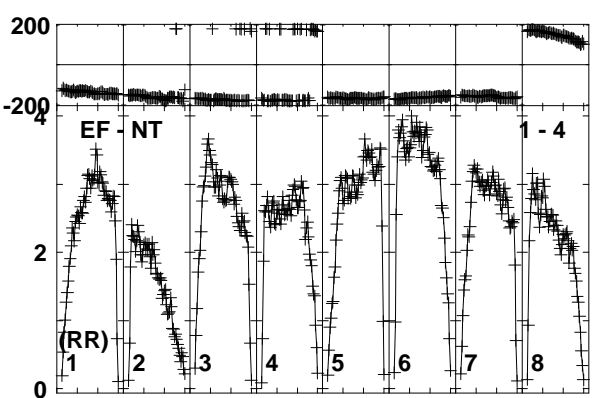
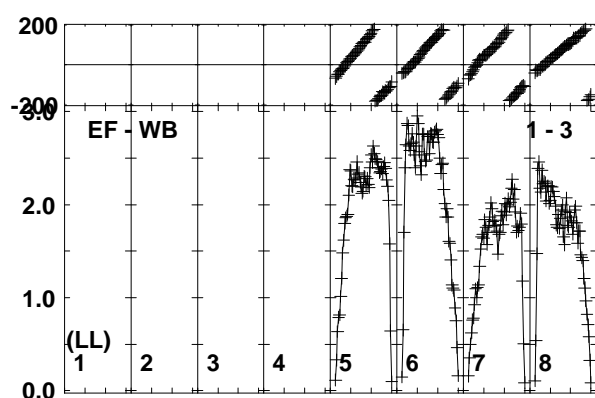
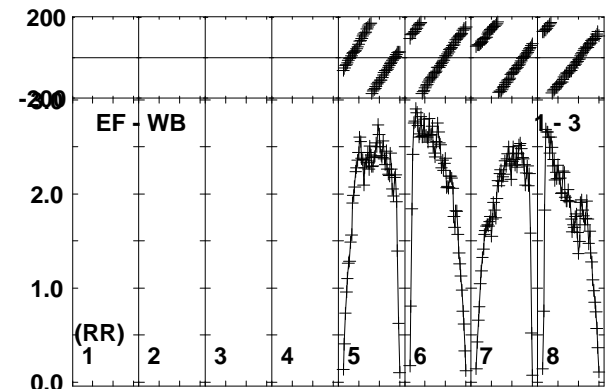
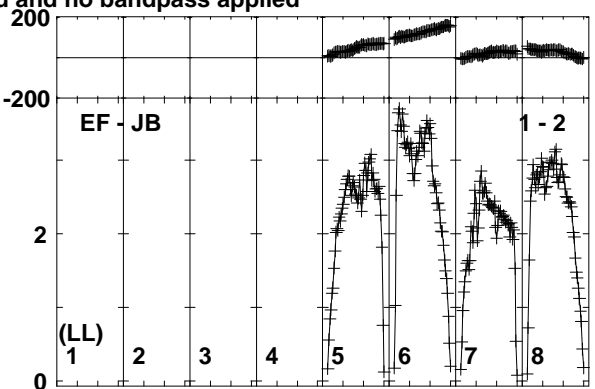
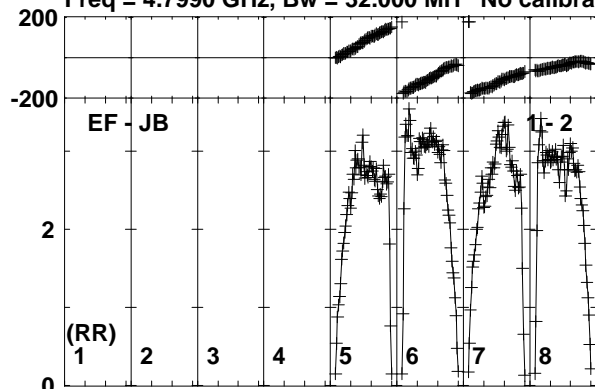

Lower frame: Milli Ampl Jy Top frame: Phas deg
Vector averaged cross-power spectrum Baseline: EF (01) - JB (02)
Timerange: 00/09:43:00 to 00/09:43:59

Plot file version 174 created 03-OCT-2017 13:27:51

J1108+4330 EG096C.UVDATA.1

Freq = 4.7990 GHz, Bw = 32.000 MH No calibration applied and no bandpass applied

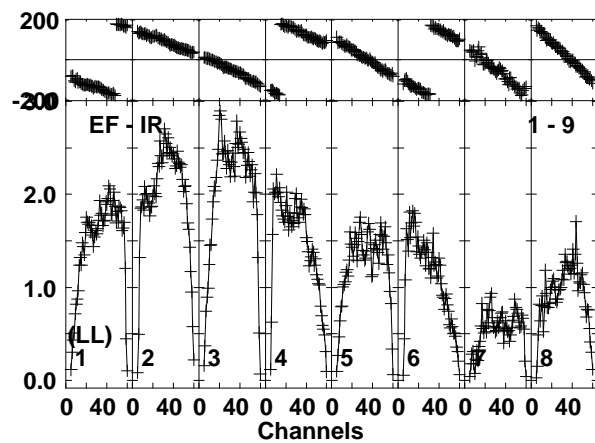
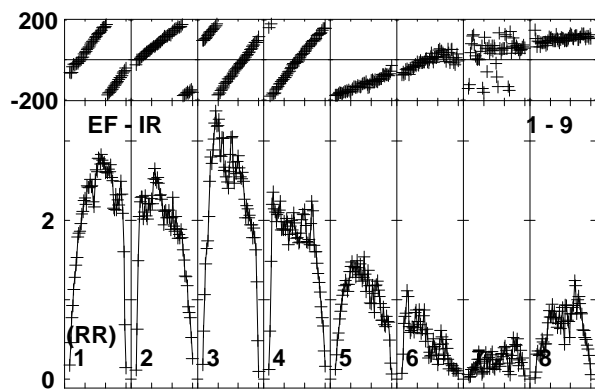
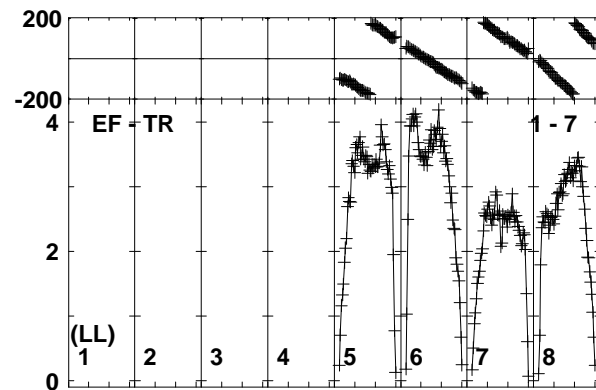
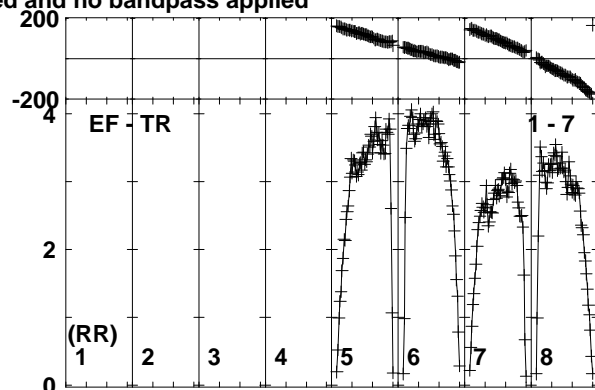
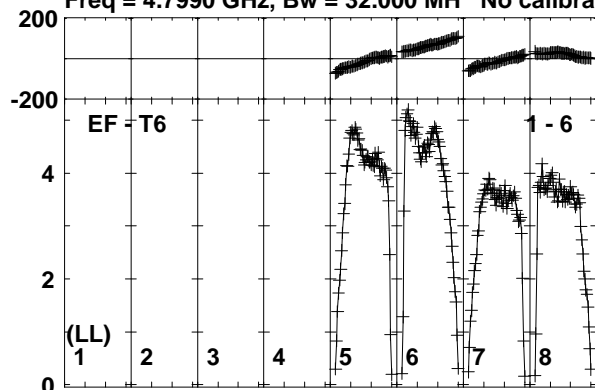

Lower frame: Milli Ampl Jy Top frame: Phas deg
Vector averaged cross-power spectrum Baseline: EF (01) - T6 (06)
Timerange: 00/09:43:00 to 00/09:43:59

Plot file version 175 created 03-OCT-2017 13:27:51

ARUMA EG096C.UVDATA.1

Freq = 4.7990 GHz, Bw = 32.000 MH No calibration applied and no bandpass applied

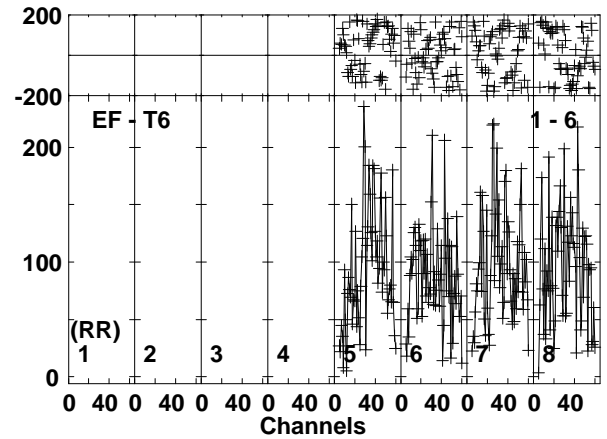
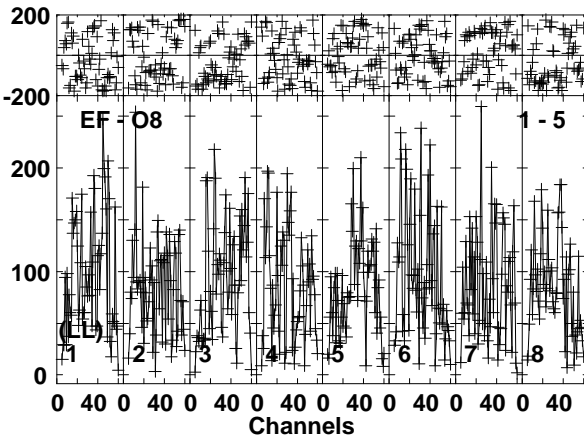
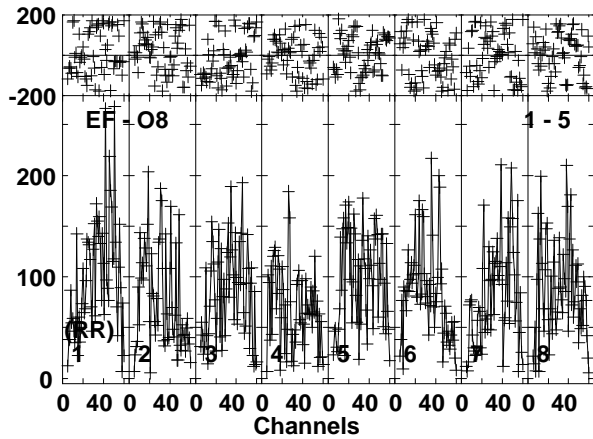
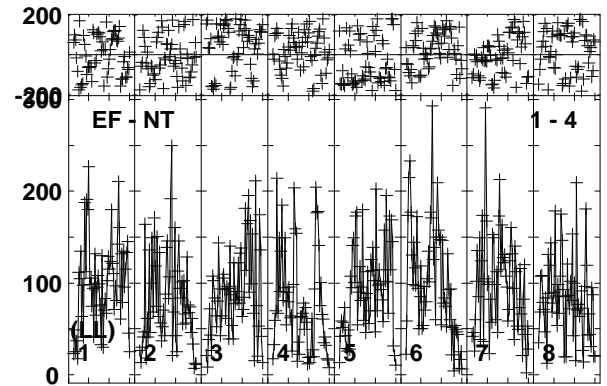
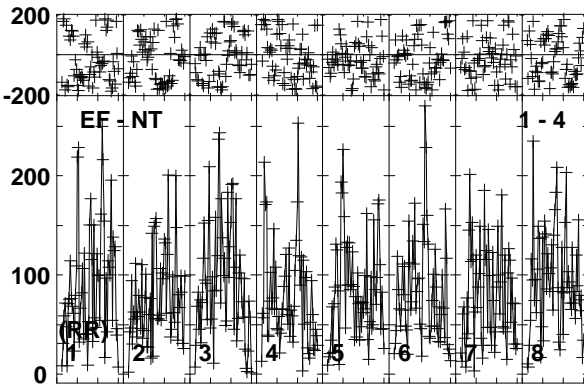
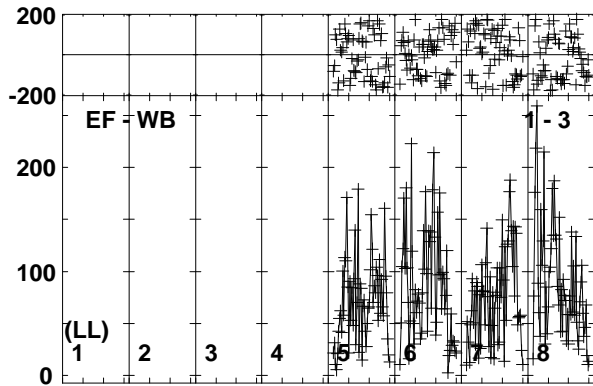
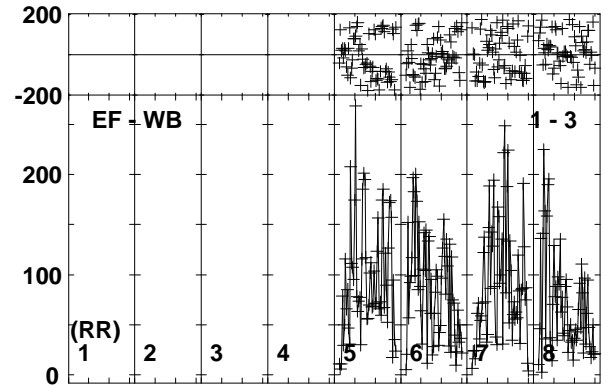
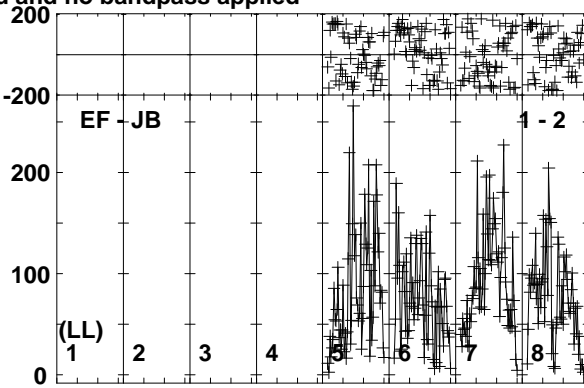
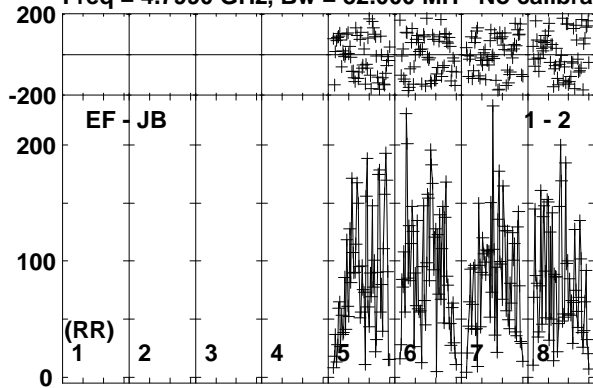

Lower frame: Micro Ampl Jy Top frame: Phas deg
Vector averaged cross-power spectrum Baseline: EF (01) - JB (02)
Timerange: 00/09:43:59 to 00/09:47:29

Plot file version 176 created 03-OCT-2017 13:27:52

ARUMA EG096C.UVDATA.1

Freq = 4.7990 GHz, Bw = 32.000 MH No calibration applied and no bandpass applied

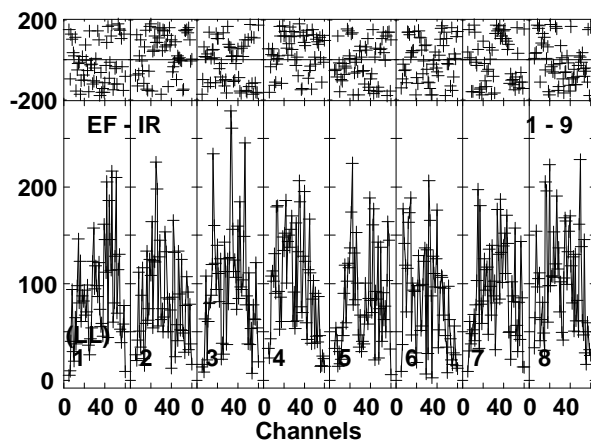
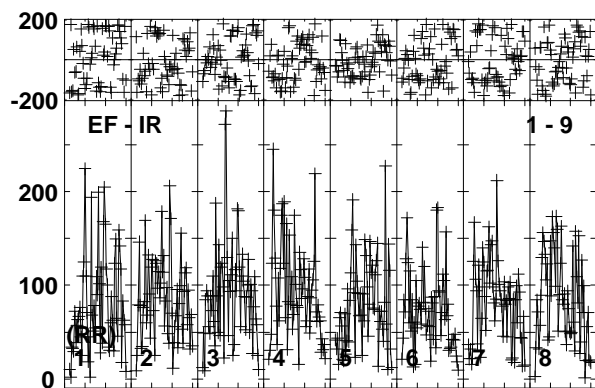
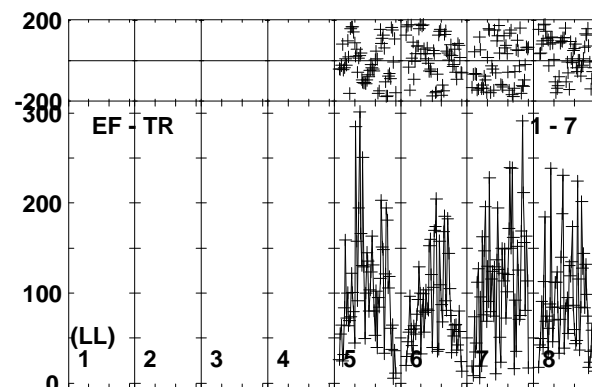
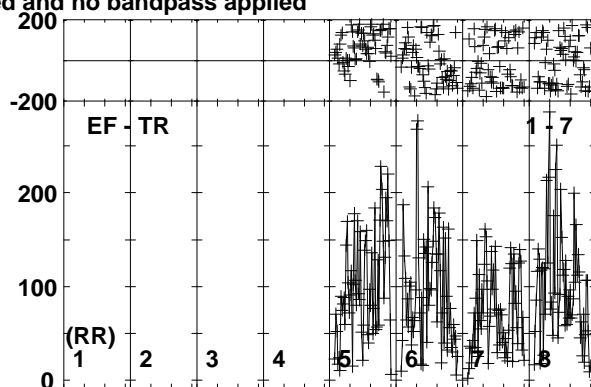
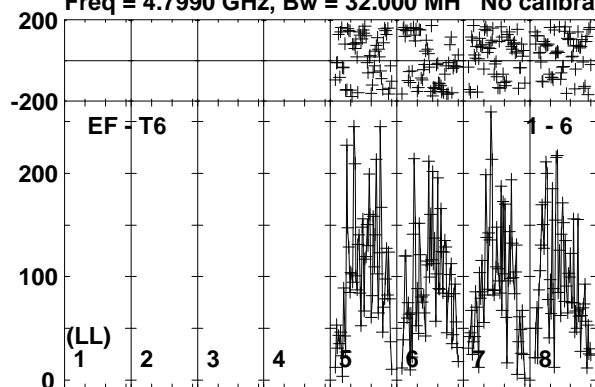

Lower frame: Micro Ampl Jy Top frame: Phas deg
Vector averaged cross-power spectrum Baseline: EF (01) - T6 (06)
Timerange: 00/09:43:59 to 00/09:47:29

Plot file version 177 created 03-OCT-2017 13:27:52

J1108+4330 EG096C.UVDATA.1

Freq = 4.7990 GHz, Bw = 32.000 MH No calibration applied and no bandpass applied

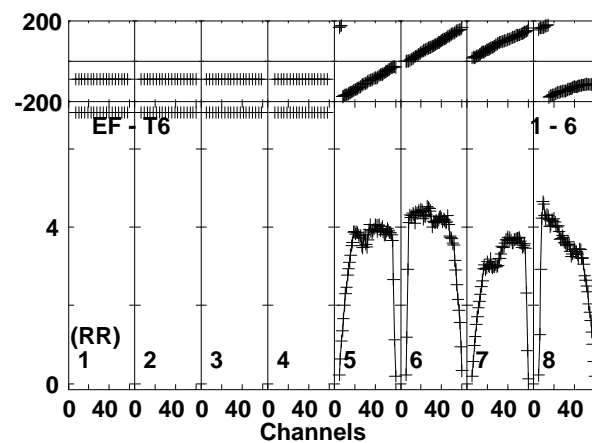
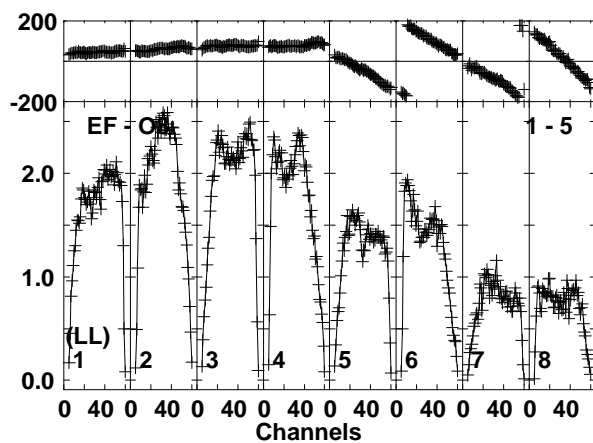
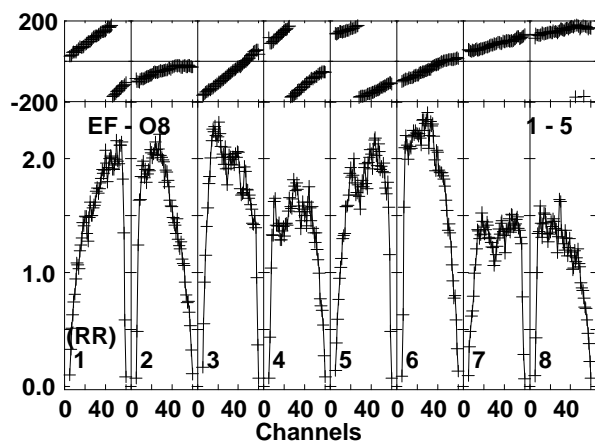
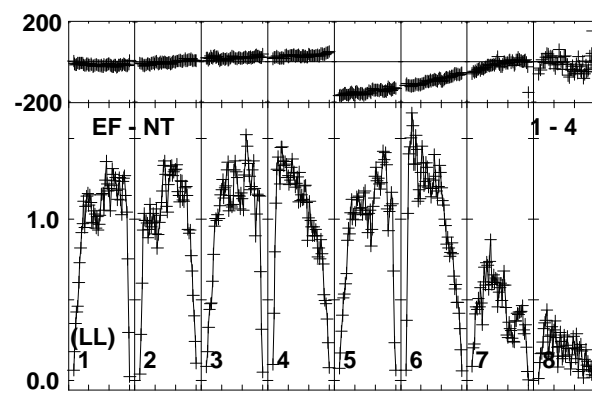
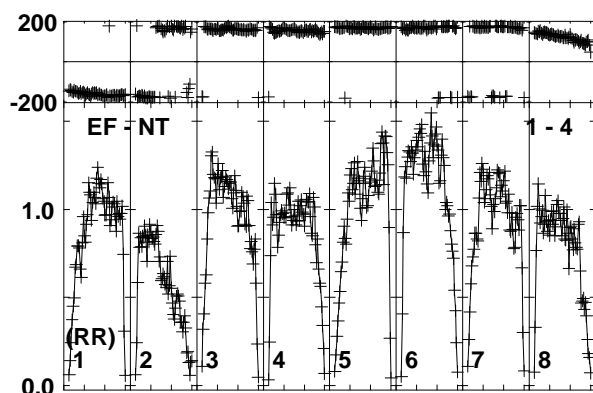
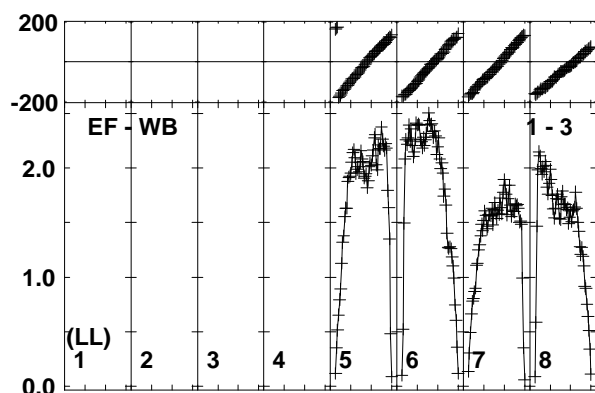
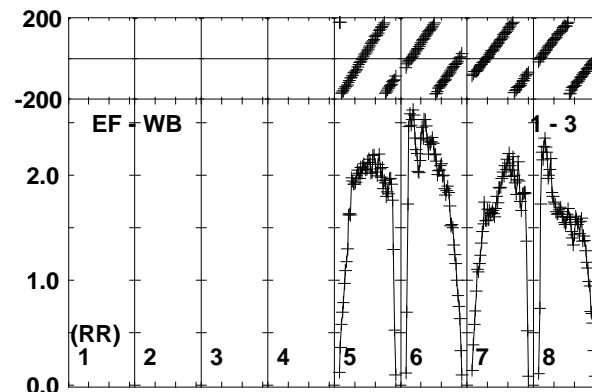
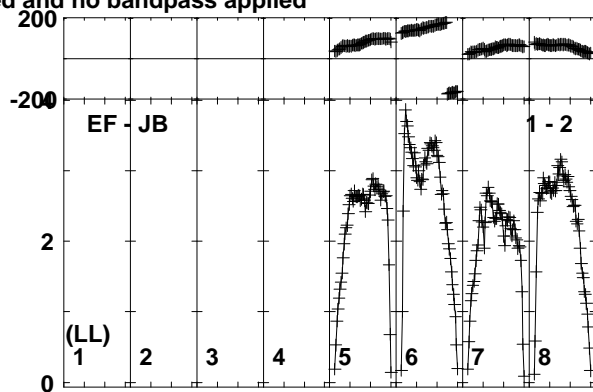
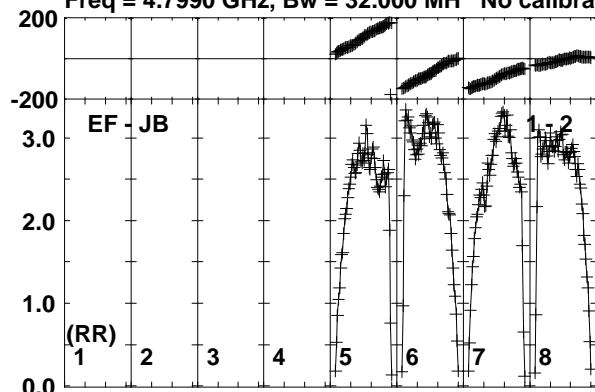

Lower frame: Milli Ampl Jy Top frame: Phas deg
Vector averaged cross-power spectrum Baseline: EF (01) - JB (02)
Timerange: 00/09:48:10 to 00/09:50:09

Plot file version 178 created 03-OCT-2017 13:27:52

J1108+4330 EG096C.UVDATA.1

Freq = 4.7990 GHz, Bw = 32.000 MH No calibration applied and no bandpass applied

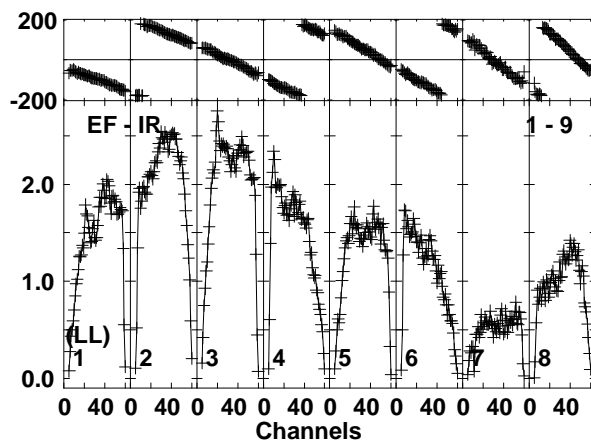
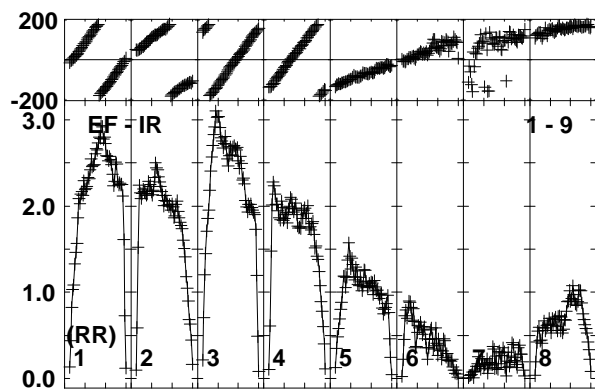
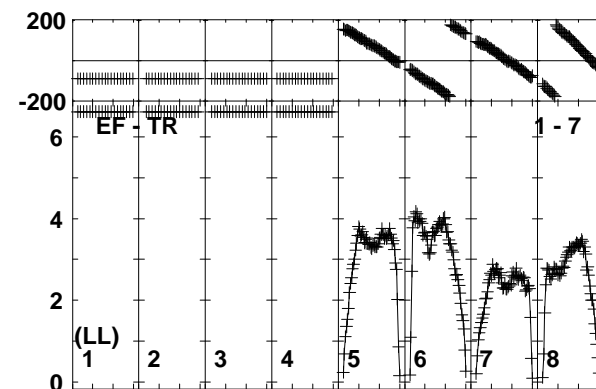
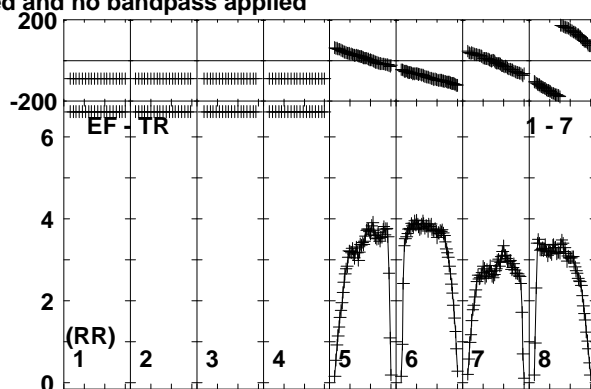
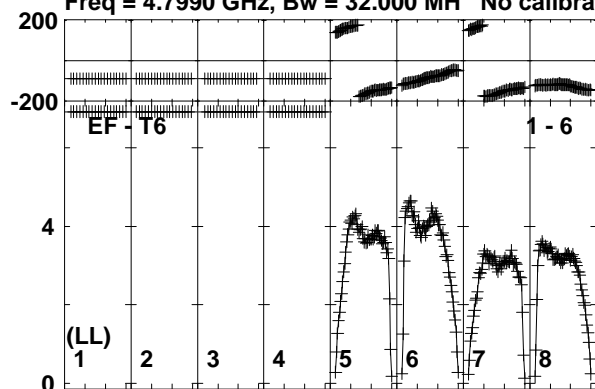

Lower frame: Milli Ampl Jy Top frame: Phas deg
Vector averaged cross-power spectrum Baseline: EF (01) - T6 (06)
Timerange: 00/09:48:10 to 00/09:50:09

Plot file version 179 created 03-OCT-2017 13:27:52

J1310+3220 EG096C.UVDATA.1

Freq = 4.7990 GHz, Bw = 32.000 MH No calibration applied and no bandpass applied

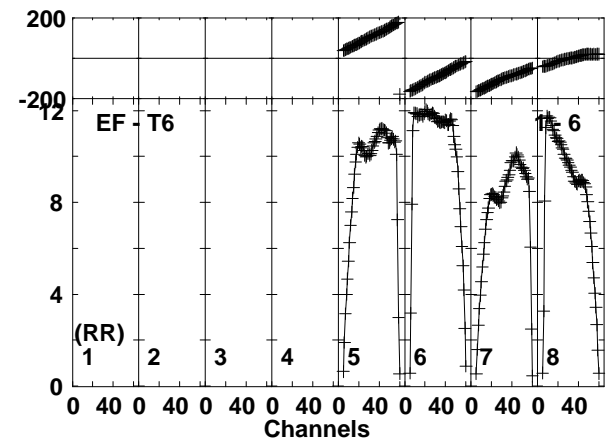
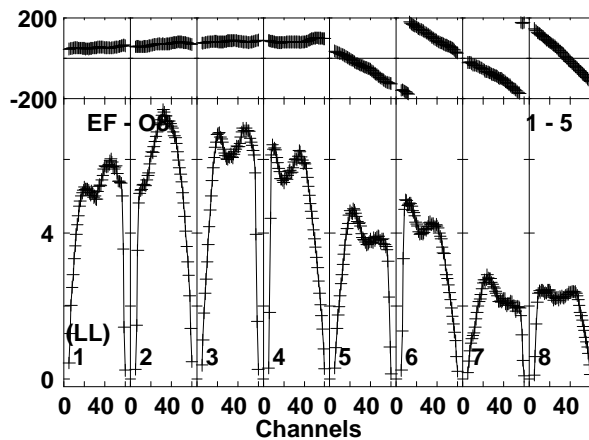
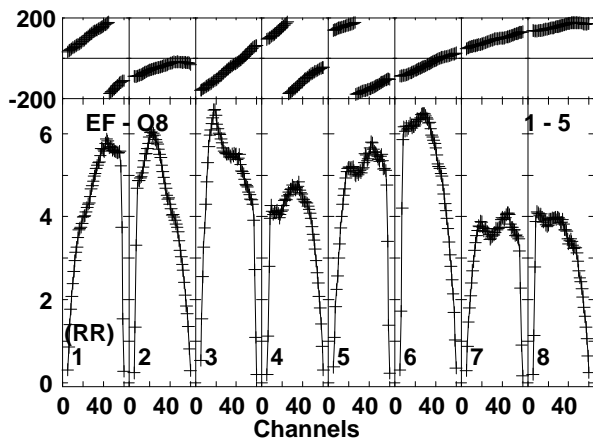
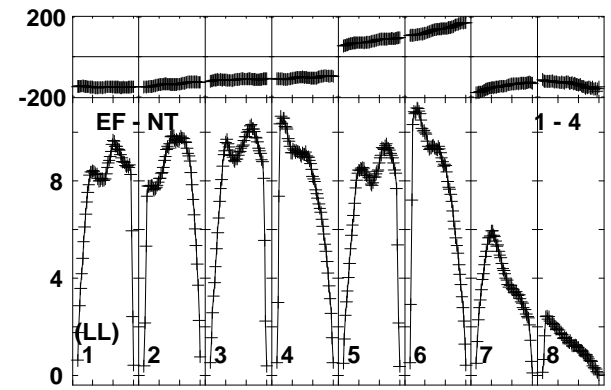
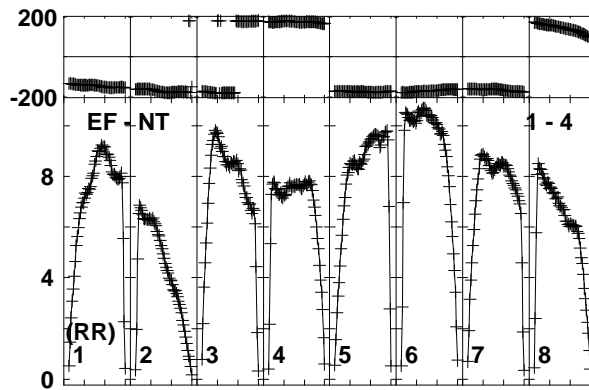
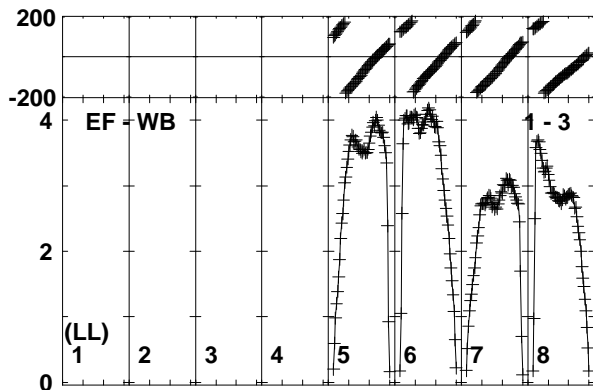
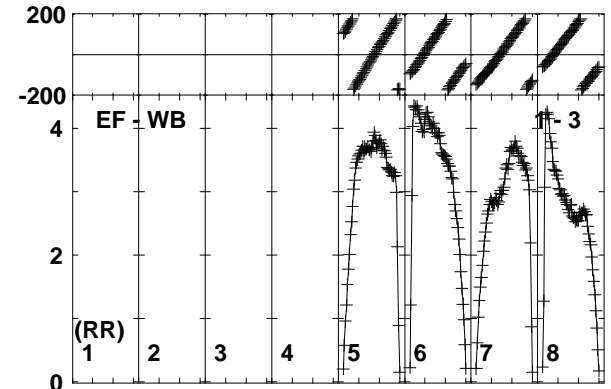
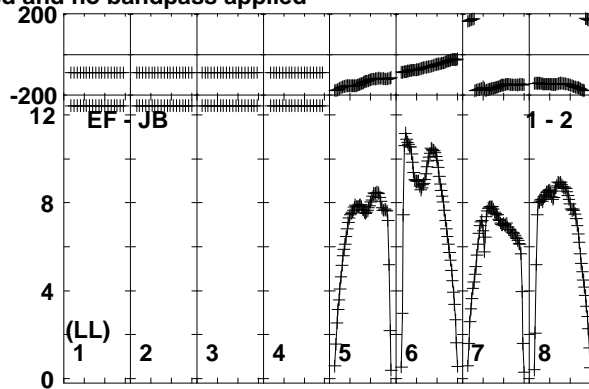
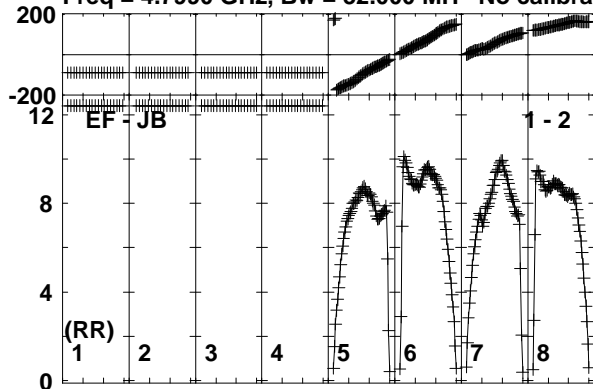

Lower frame: Milli Ampl Jy Top frame: Phas deg
Vector averaged cross-power spectrum Baseline: EF (01) - JB (02)
Timerange: 00/09:52:39 to 00/09:58:36

Plot file version 180 created 03-OCT-2017 13:27:53

J1310+3220 EG096C.UVDATA.1

Freq = 4.7990 GHz, Bw = 32.000 MH No calibration applied and no bandpass applied

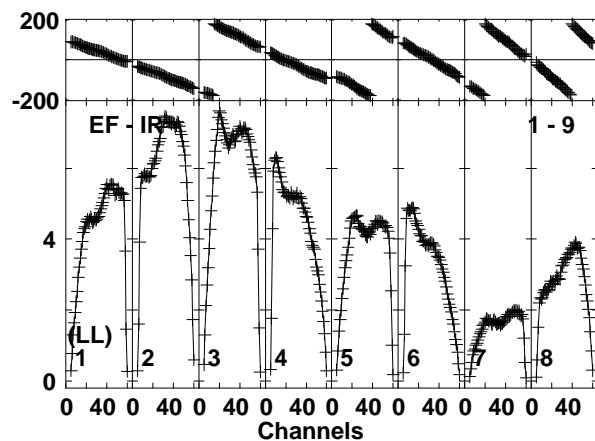
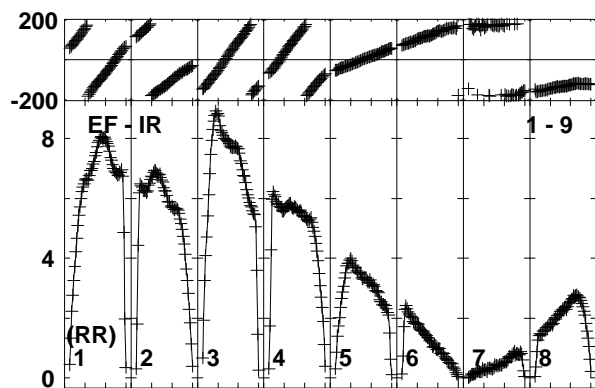
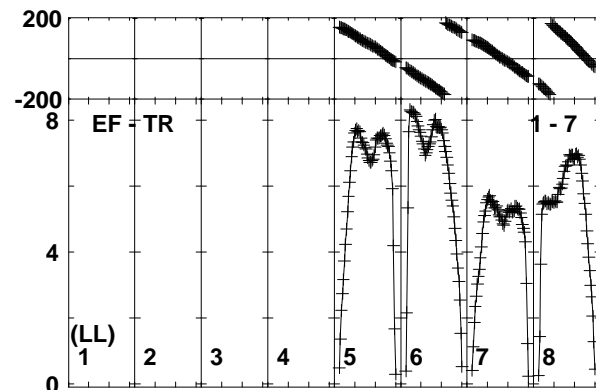
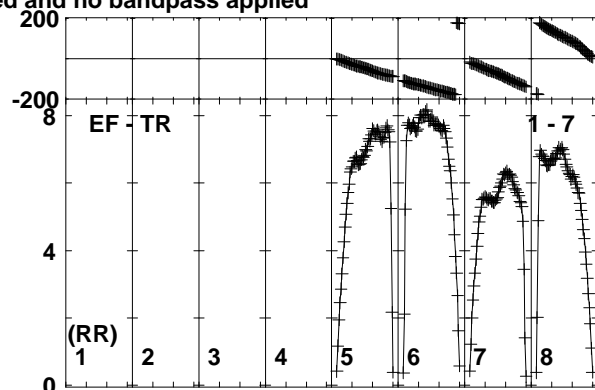
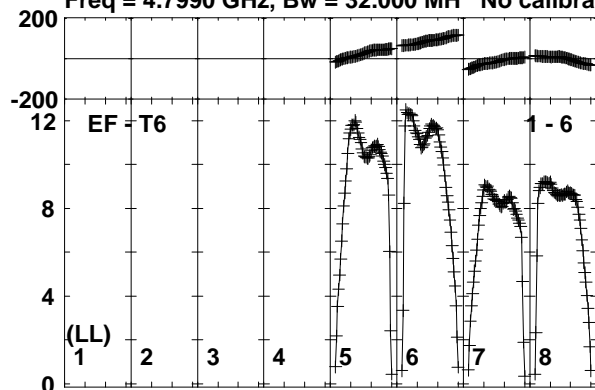

Lower frame: Milli Ampl Jy Top frame: Phas deg
Vector averaged cross-power spectrum Baseline: EF (01) - T6 (06)
Timerange: 00/09:52:39 to 00/09:58:36