

Plot file version 1 created 05-OCT-2009 09:28:16

3C345 EH023B 2.UVDATA.1

Freq = 8.3535 GHz, Bw = 8.000 MH No calibration applied and no bandpass applied

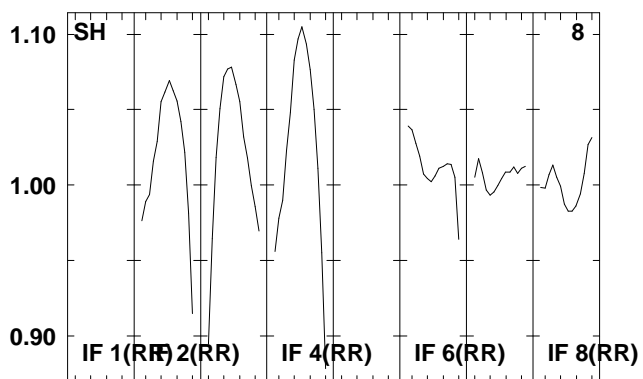
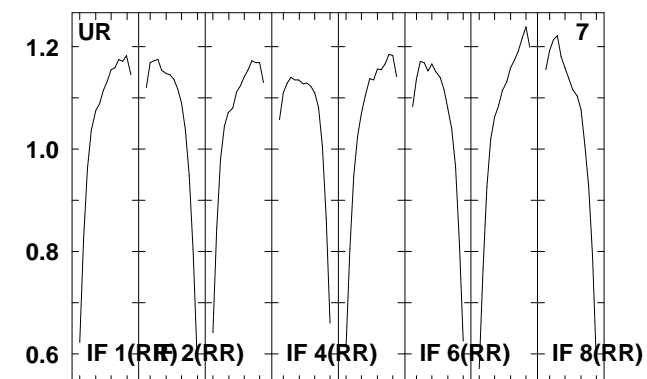
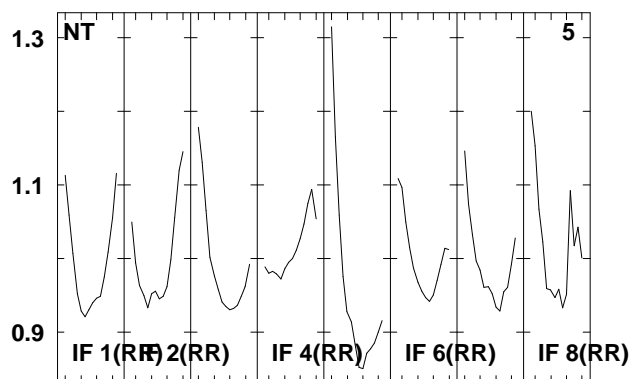
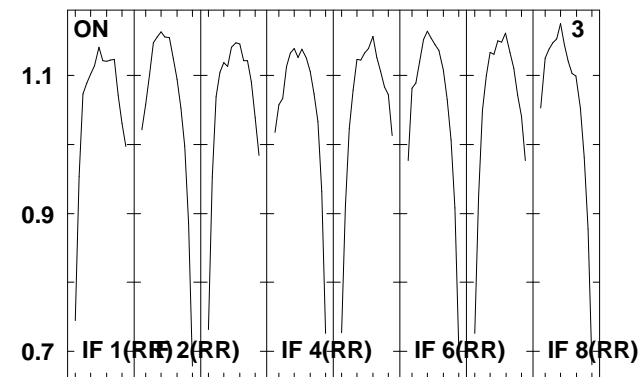
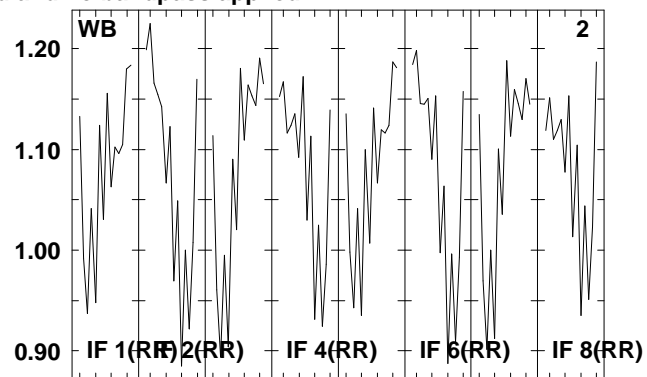
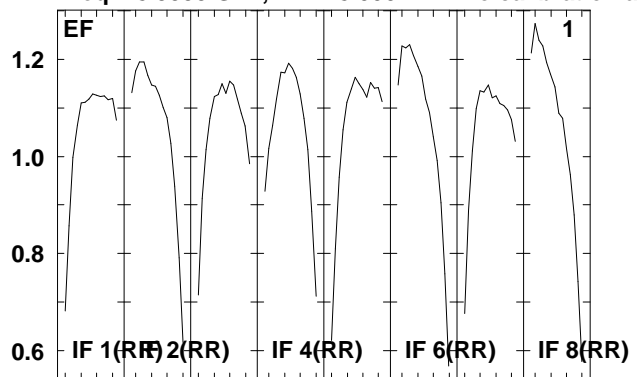

Lower frame: Real Jy  
Total-power spectrum Antenna: \*  
Timerange: 00/17:30:01 to 00/17:34:59

Plot file version 2 created 05-OCT-2009 09:28:16

J1651+01 EH023B 2.UVDATA.1

Freq = 8.3535 GHz, Bw = 8.000 MH No calibration applied and no bandpass applied

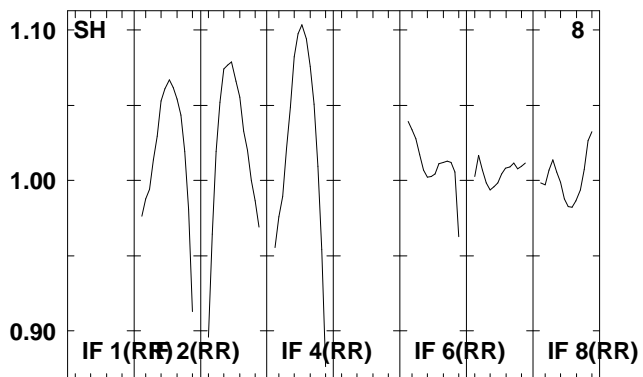
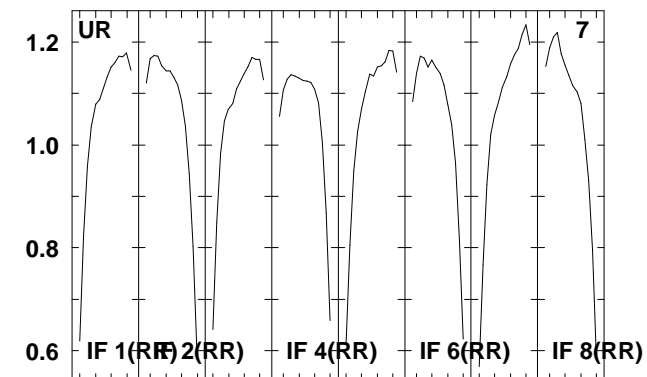
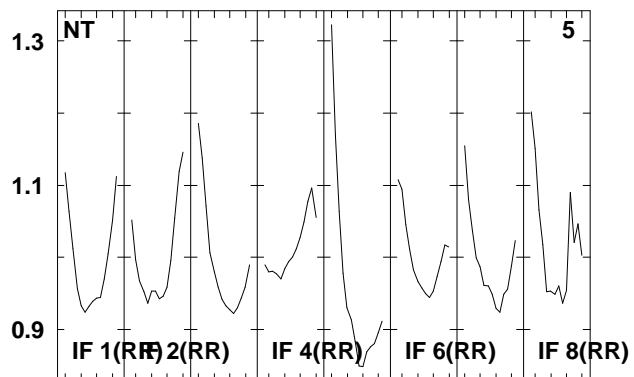
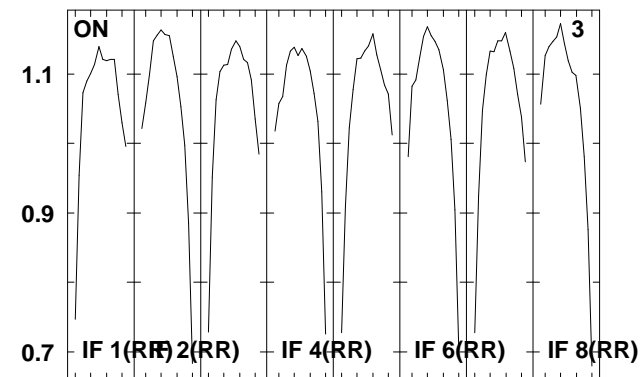
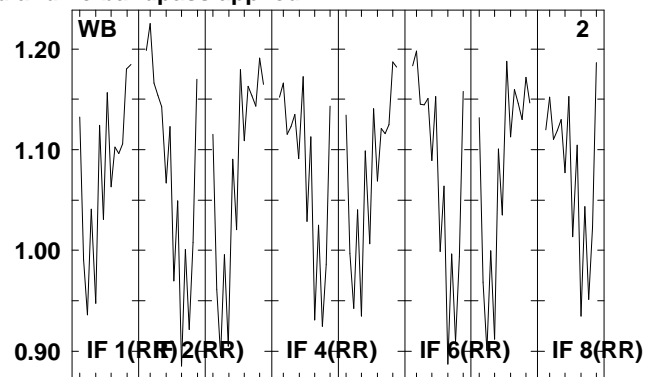
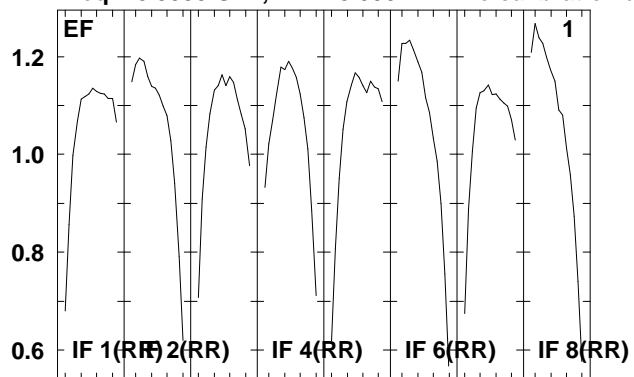

Lower frame: Real Jy  
Total-power spectrum Antenna: \*  
Timerange: 00/17:40:05 to 00/17:41:35

Plot file version 3 created 05-OCT-2009 09:28:16

NGC6240 EH023B 2.UVDATA.1

Freq = 8.3535 GHz, Bw = 8.000 MH No calibration applied and no bandpass applied

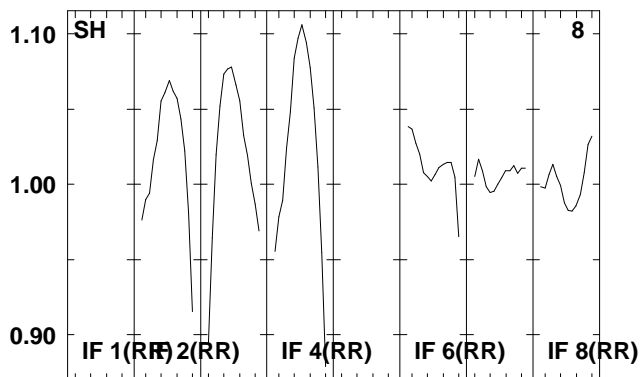
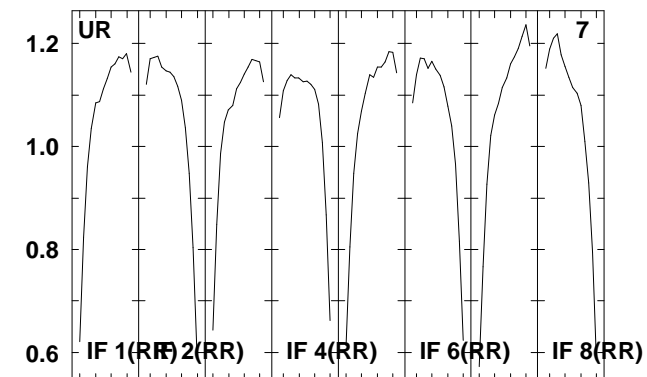
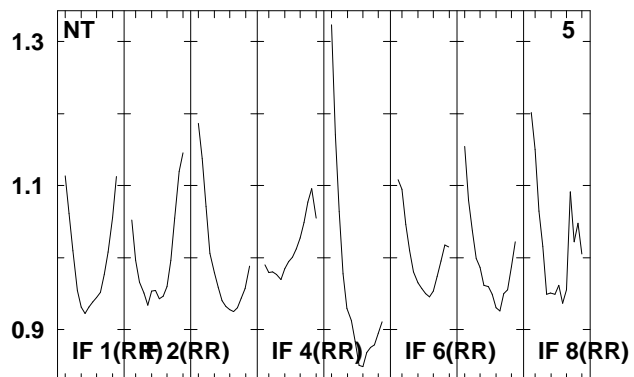
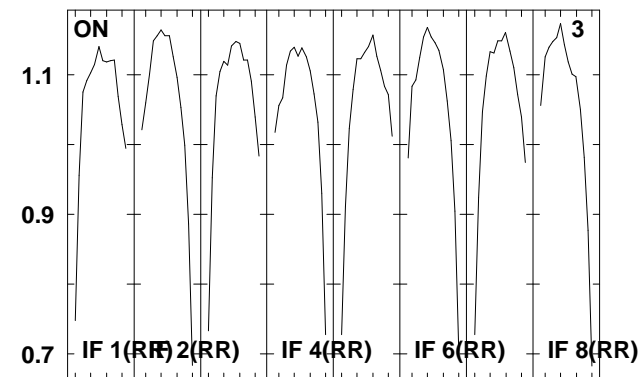
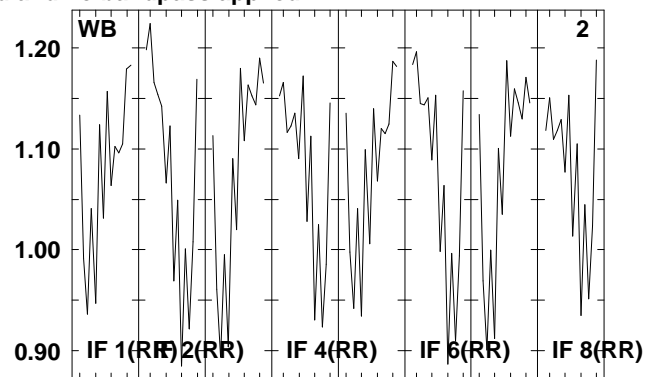
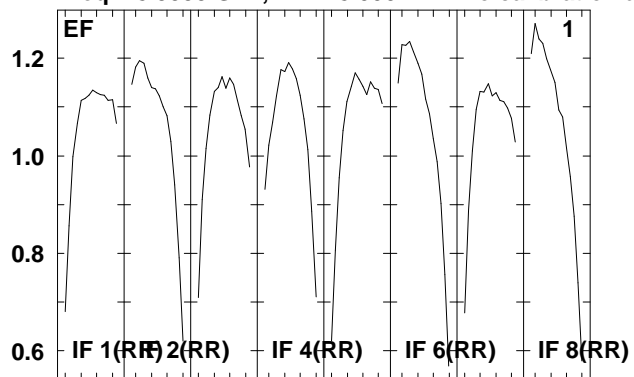

Lower frame: Real Jy  
Total-power spectrum Antenna: \*  
Timerange: 00/17:41:37 to 00/17:45:03

Plot file version 4 created 05-OCT-2009 09:28:16

J1651+01 EH023B 2.UVDATA.1

Freq = 8.3535 GHz, Bw = 8.000 MH No calibration applied and no bandpass applied

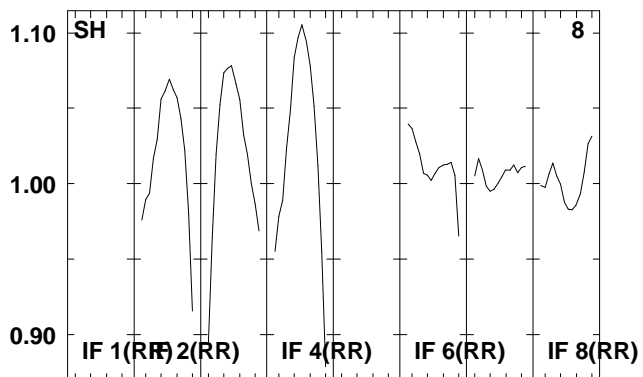
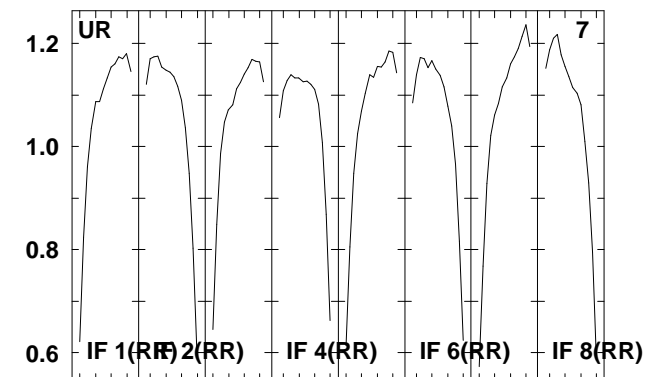
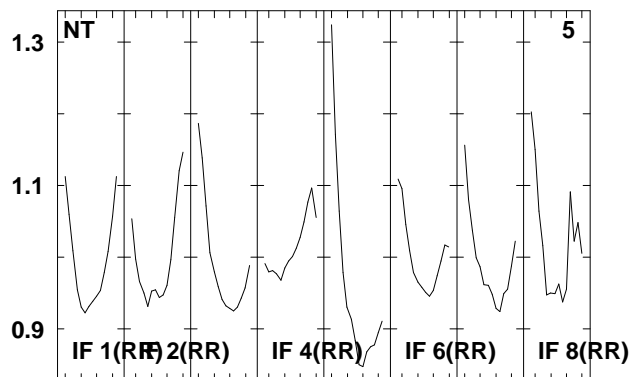
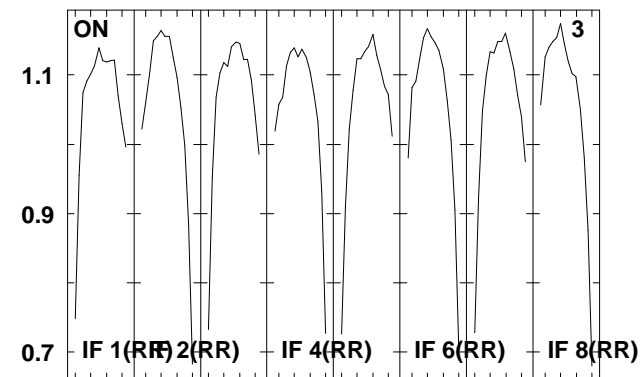
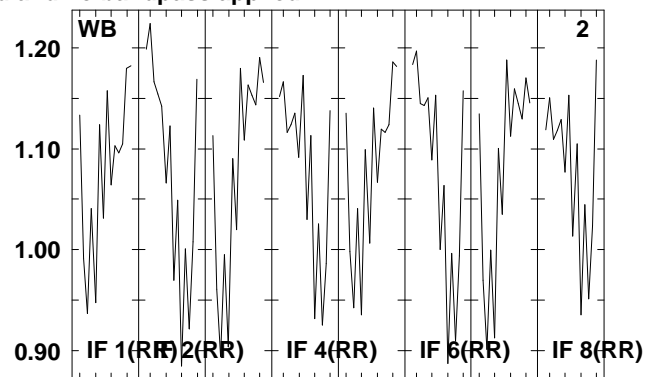
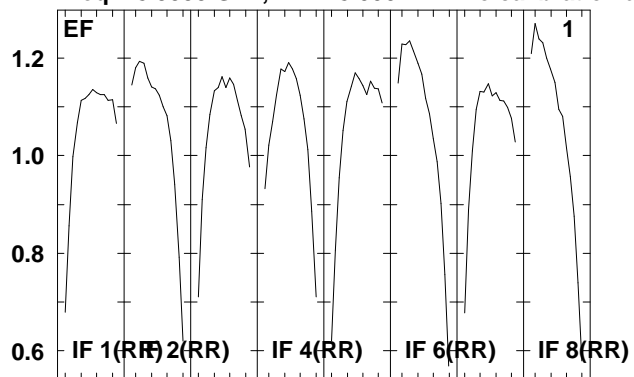

Lower frame: Real Jy  
Total-power spectrum Antenna: \*  
Timerange: 00/17:45:05 to 00/17:46:33

Plot file version 5 created 05-OCT-2009 09:28:16

NGC6240 EH023B 2.UVDATA.1

Freq = 8.3535 GHz, Bw = 8.000 MH No calibration applied and no bandpass applied

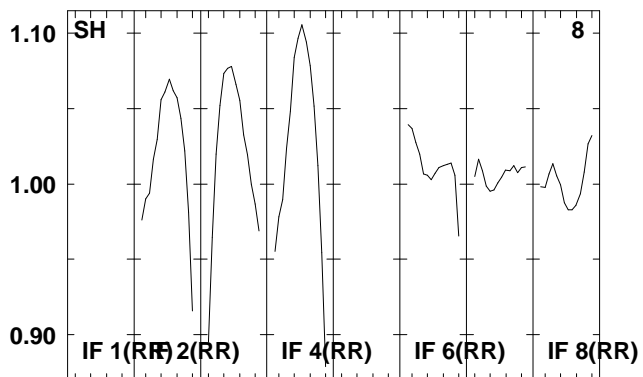
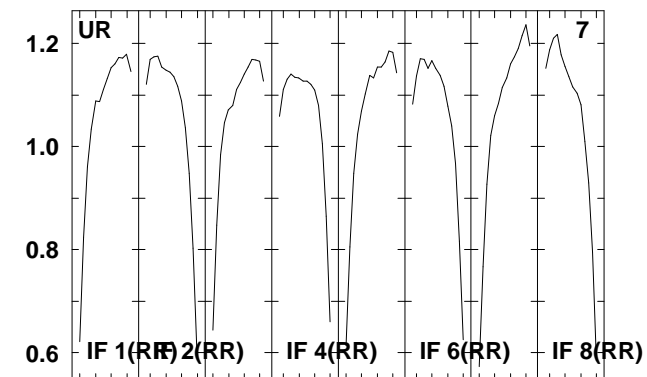
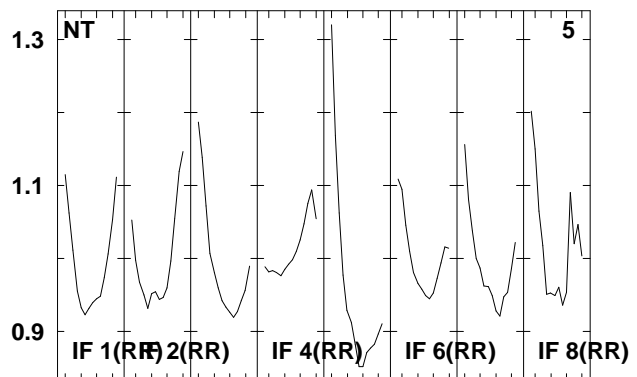
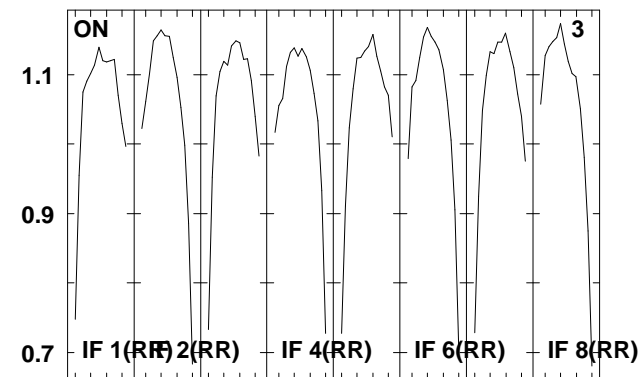
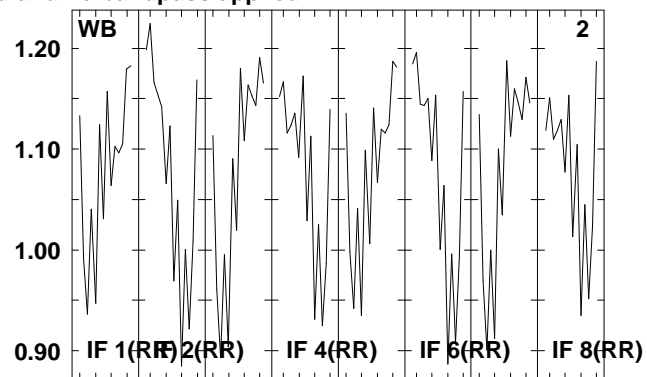
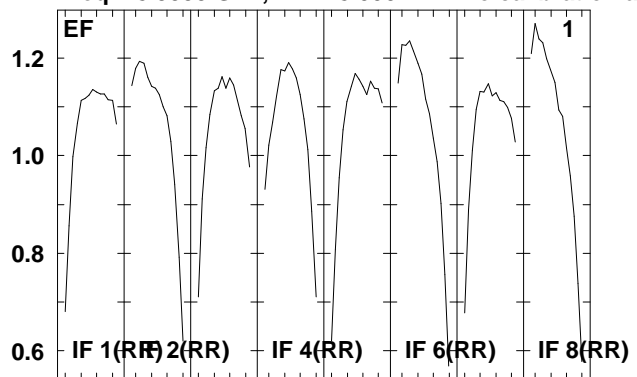

Lower frame: Real Jy  
Total-power spectrum Antenna: \*  
Timerange: 00/17:46:35 to 00/17:50:03

Plot file version 6 created 05-OCT-2009 09:28:16

J1651+01 EH023B 2.UVDATA.1

Freq = 8.3535 GHz, Bw = 8.000 MH No calibration applied and no bandpass applied

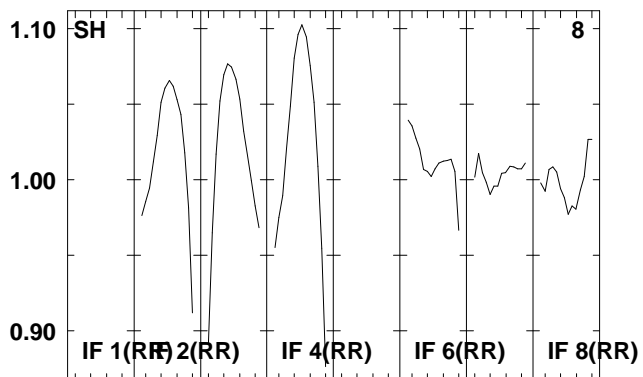
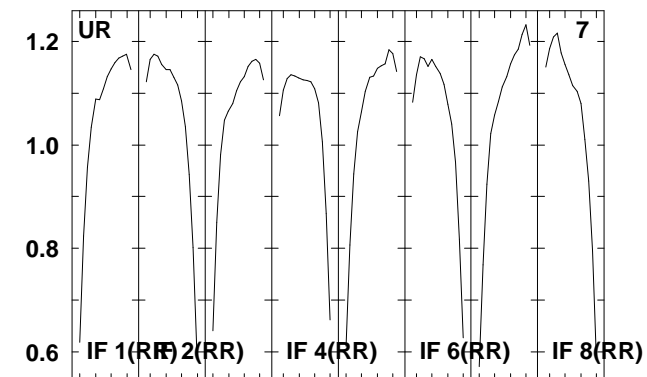
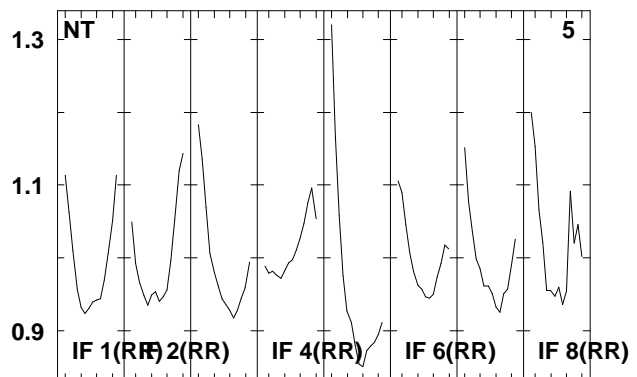
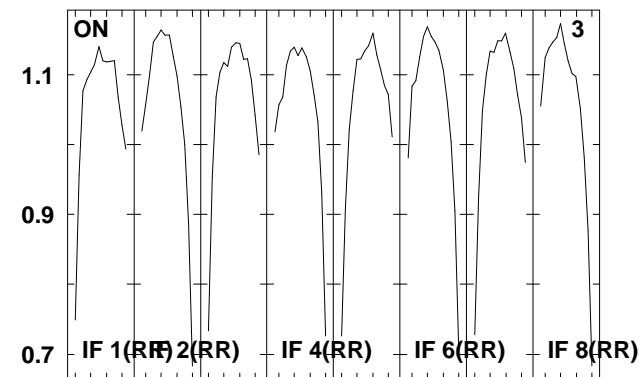
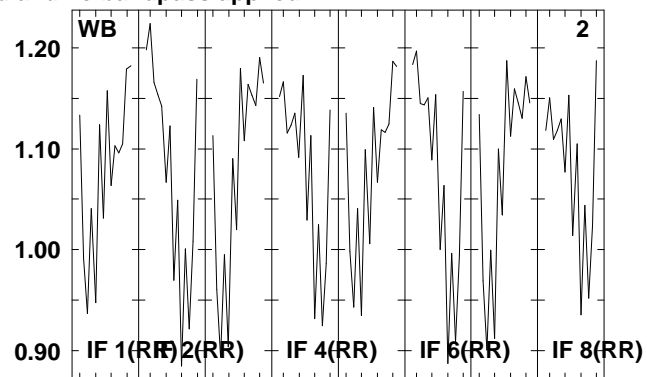
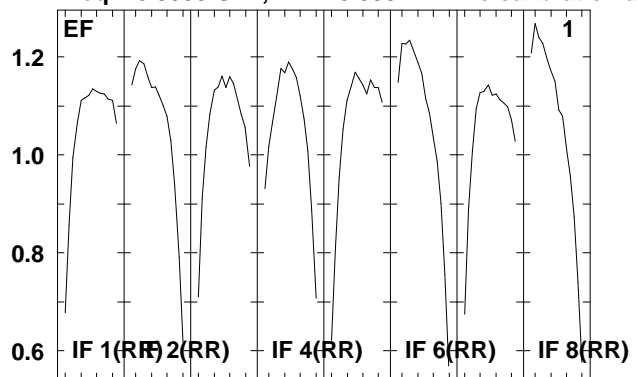

Lower frame: Real Jy  
Total-power spectrum Antenna: \*  
Timerange: 00/17:50:37 to 00/17:52:03

Plot file version 7 created 05-OCT-2009 09:28:17

NGC6240 EH023B 2.UVDATA.1

Freq = 8.3535 GHz, Bw = 8.000 MH No calibration applied and no bandpass applied

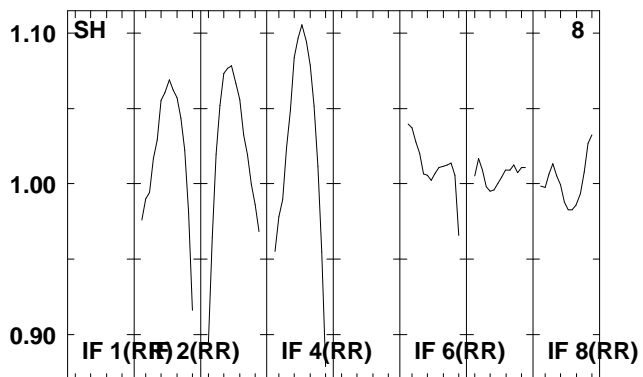
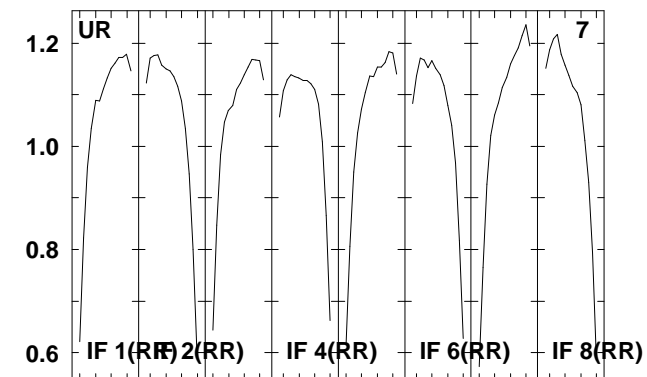
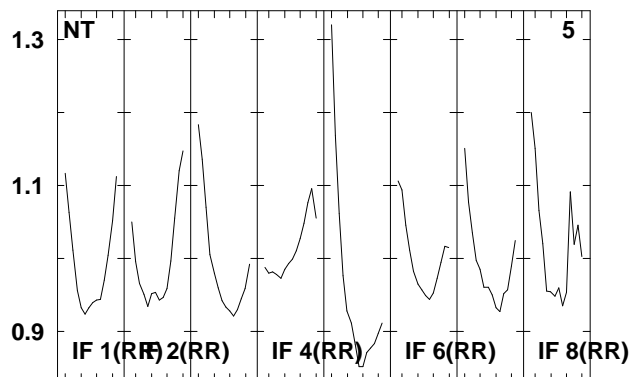
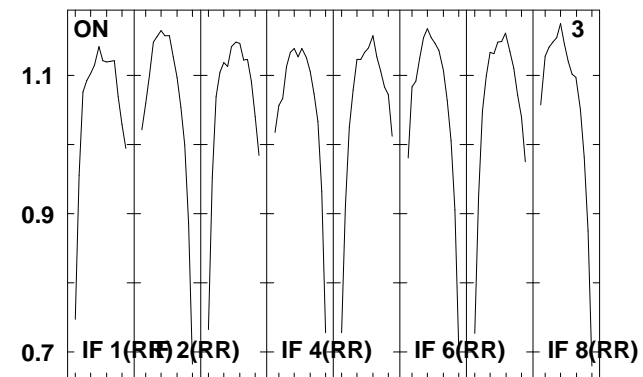
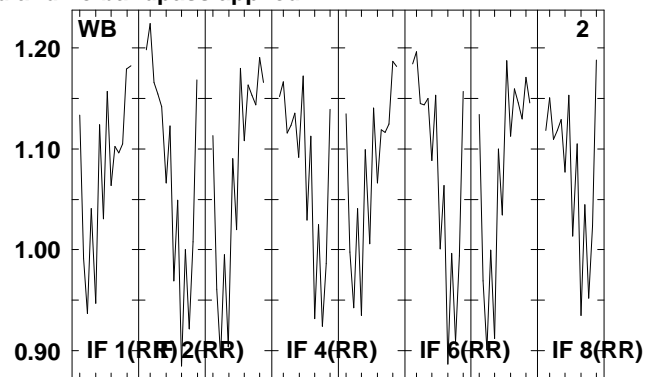
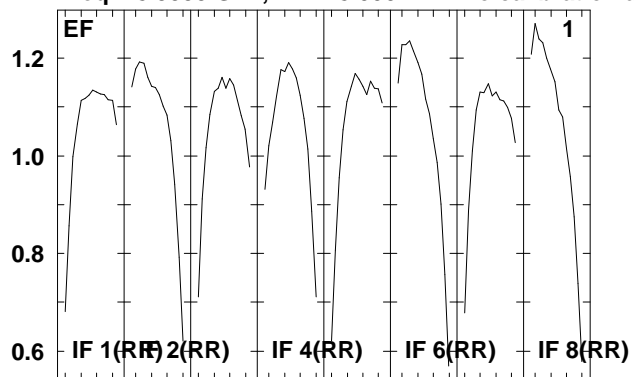

Lower frame: Real Jy  
Total-power spectrum Antenna: \*  
Timerange: 00/17:52:05 to 00/17:55:33

Plot file version 8 created 05-OCT-2009 09:28:17

J1651+01 EH023B 2.UVDATA.1

Freq = 8.3535 GHz, Bw = 8.000 MH No calibration applied and no bandpass applied

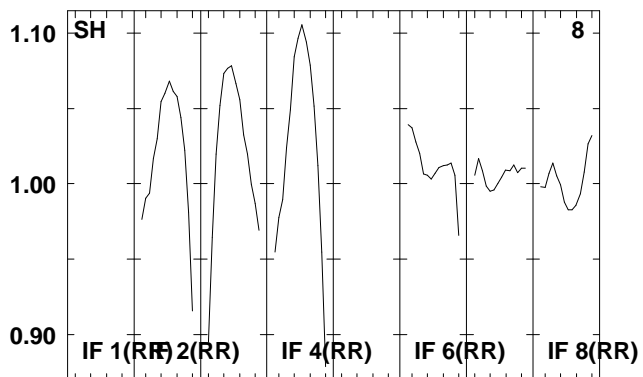
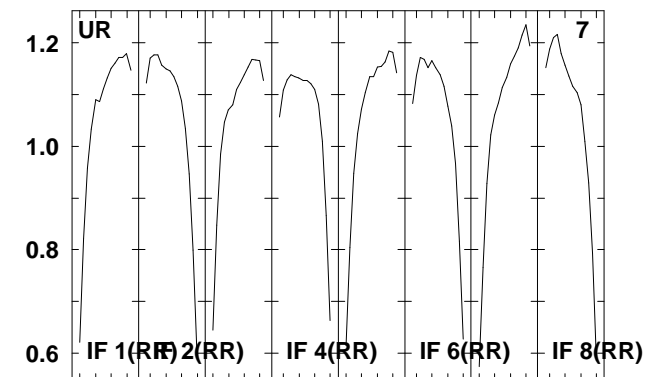
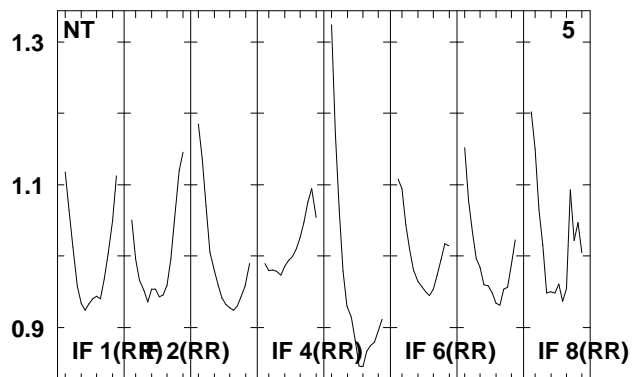
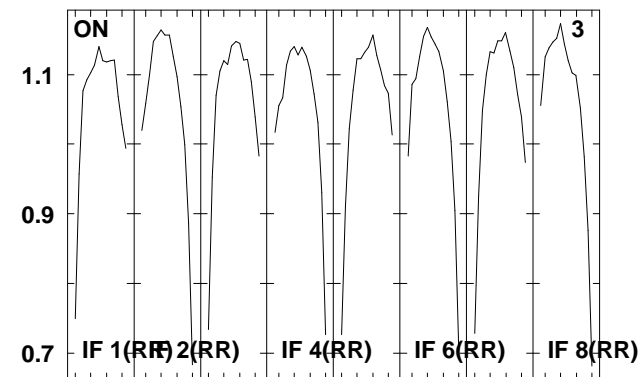
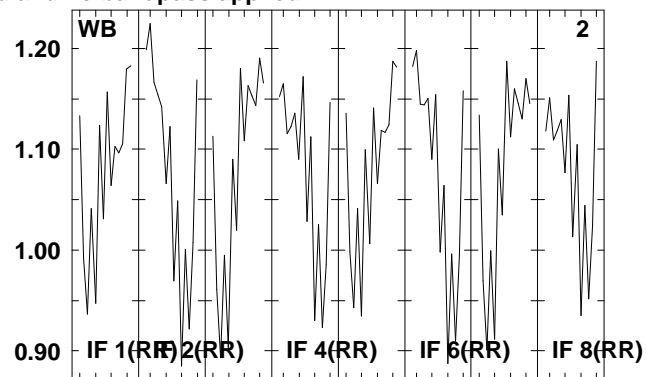
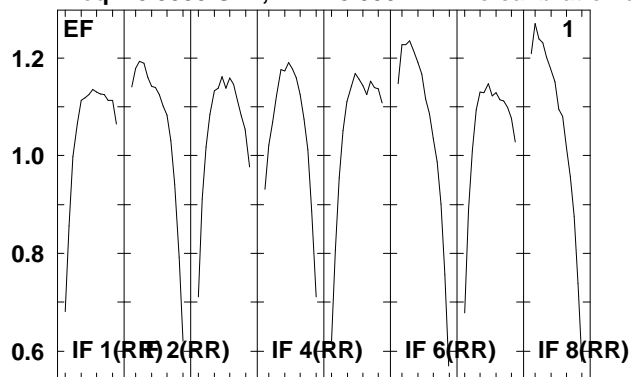

Lower frame: Real Jy  
Total-power spectrum Antenna: \*  
Timerange: 00/17:55:35 to 00/17:57:05



Plot file version 9 created 05-OCT-2009 09:28:17

NGC6240 EH023B 2.UVDATA.1

Freq = 8.3535 GHz, Bw = 8.000 MH No calibration applied and no bandpass applied

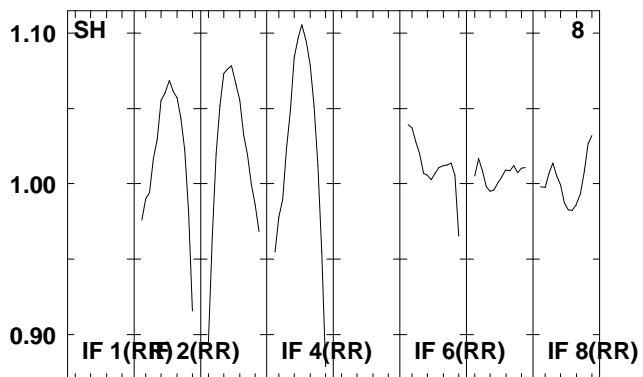
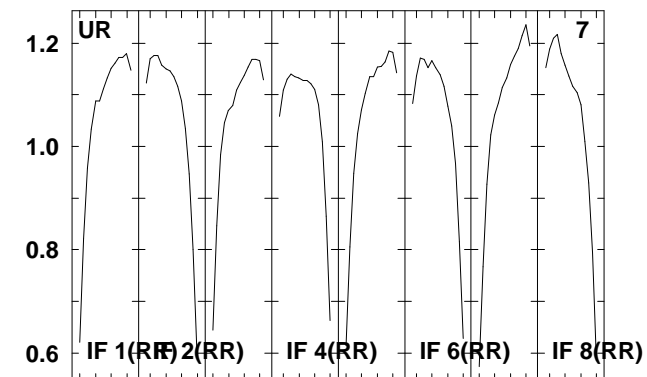
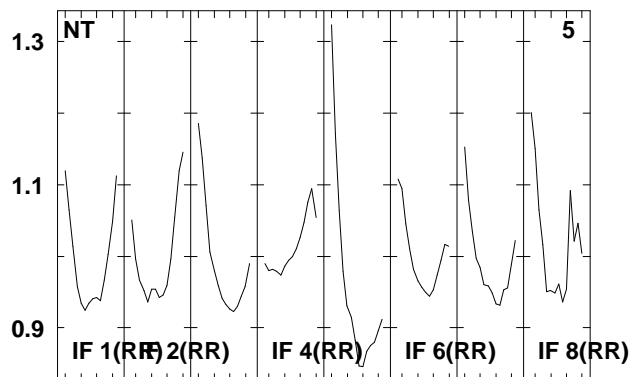
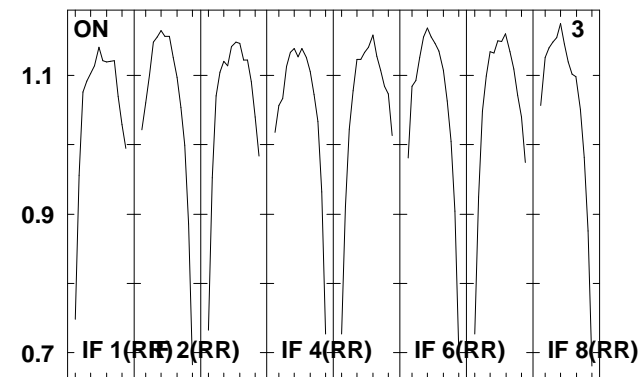
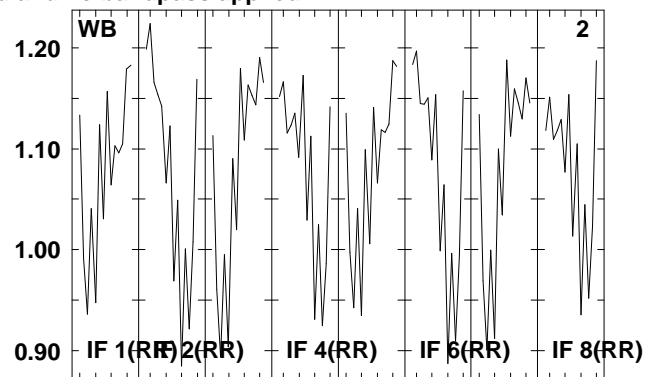
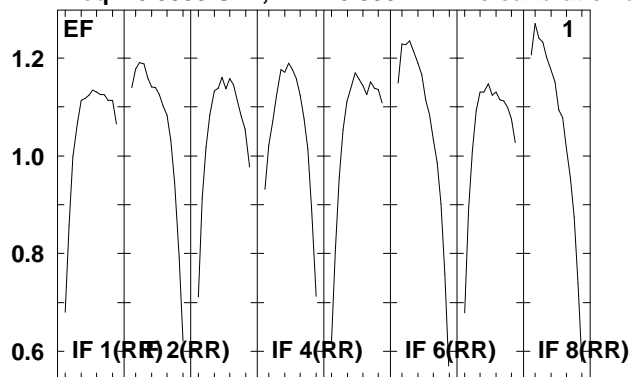

Lower frame: Real Jy  
Total-power spectrum Antenna: \*  
Timerange: 00/17:57:07 to 00/18:00:33

Plot file version 10 created 05-OCT-2009 09:28:17

J1651+01 EH023B 2.UVDATA.1

Freq = 8.3535 GHz, Bw = 8.000 MH No calibration applied and no bandpass applied

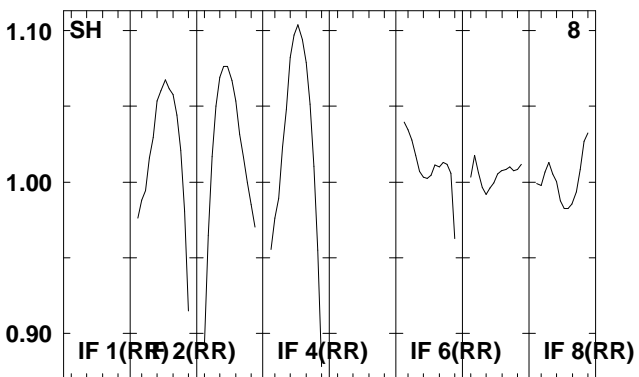
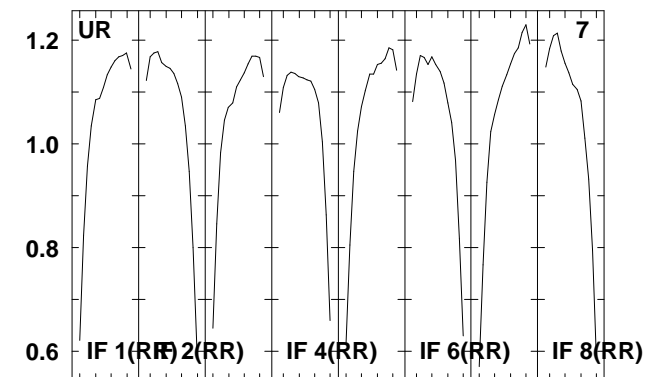
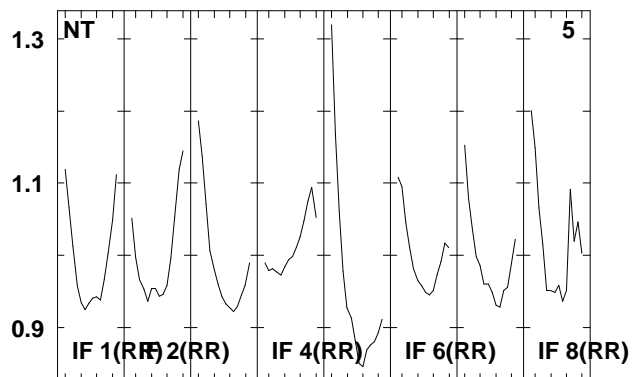
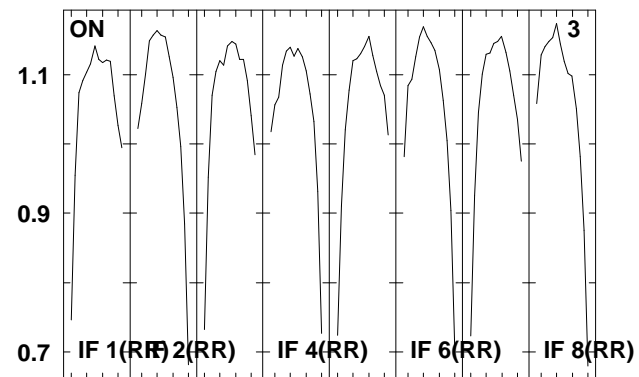
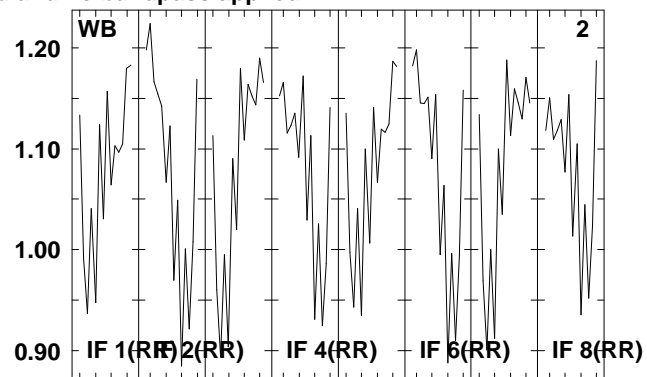
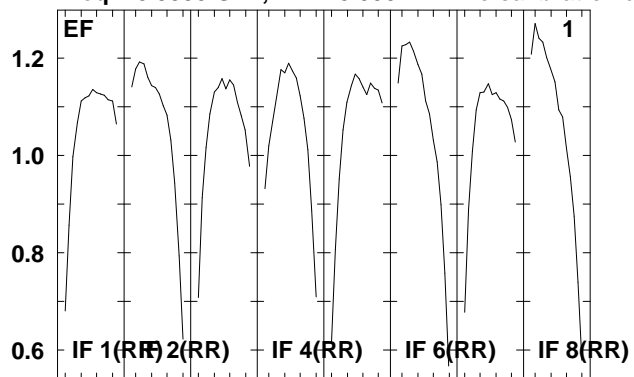

Lower frame: Real Jy  
Total-power spectrum Antenna: \*  
Timerange: 00/18:01:05 to 00/18:02:33

Plot file version 11 created 05-OCT-2009 09:28:17

NGC6240 EH023B 2.UVDATA.1

Freq = 8.3535 GHz, Bw = 8.000 MH No calibration applied and no bandpass applied

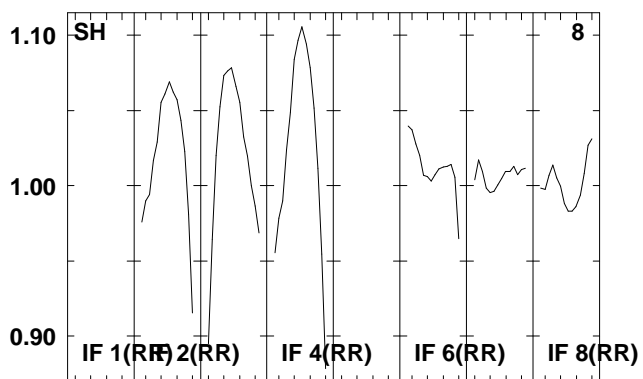
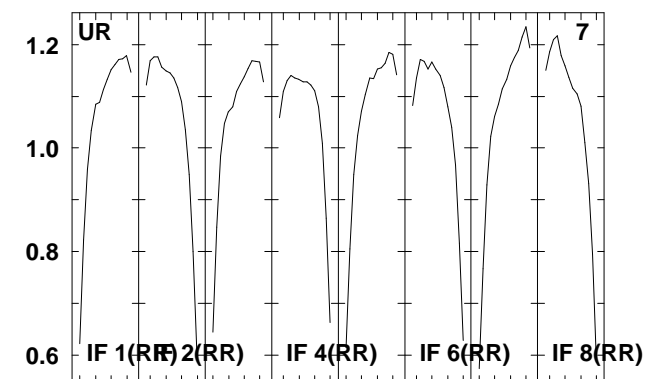
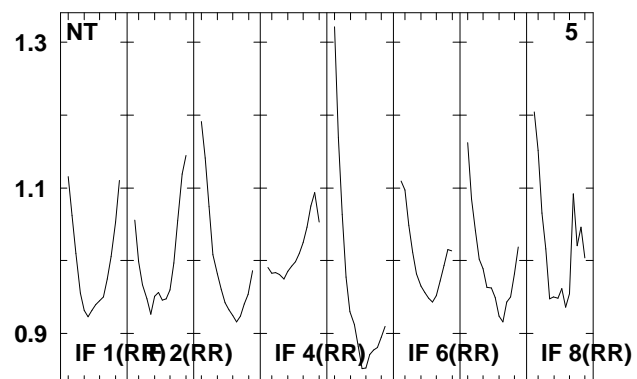
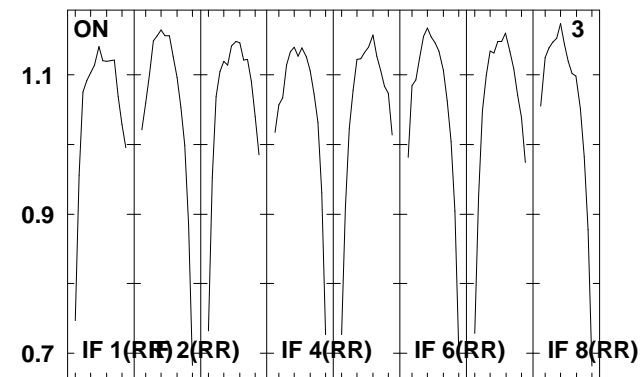
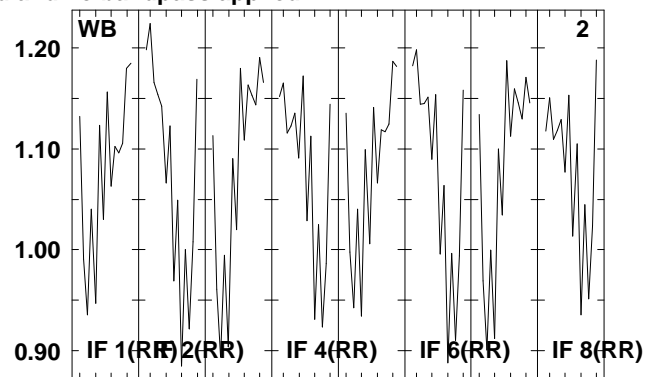
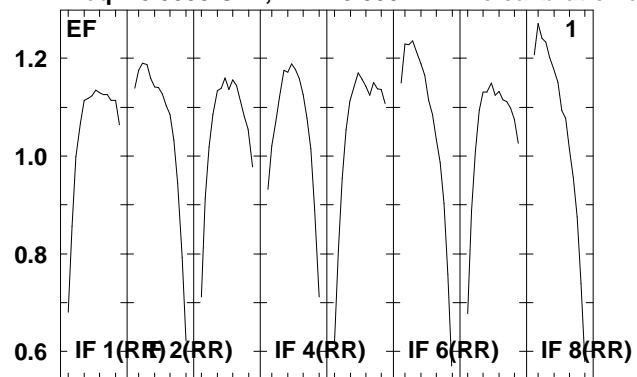

Lower frame: Real Jy  
Total-power spectrum Antenna: \*  
Timerange: 00/18:02:35 to 00/18:06:05

Plot file version 12 created 05-OCT-2009 09:28:17

J1651+01 EH023B 2.UVDATA.1

Freq = 8.3535 GHz, Bw = 8.000 MH No calibration applied and no bandpass applied

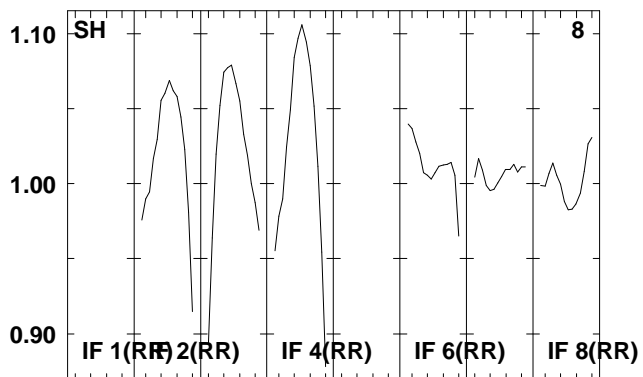
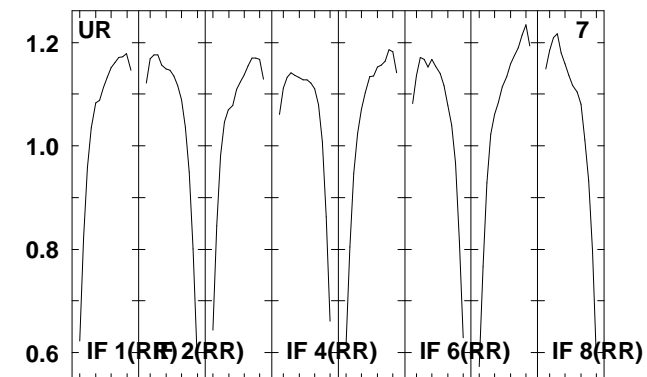
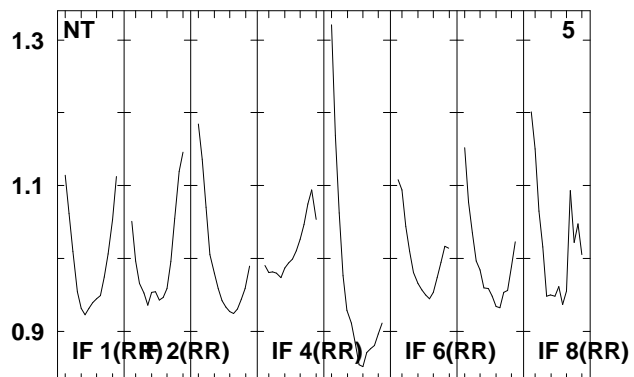
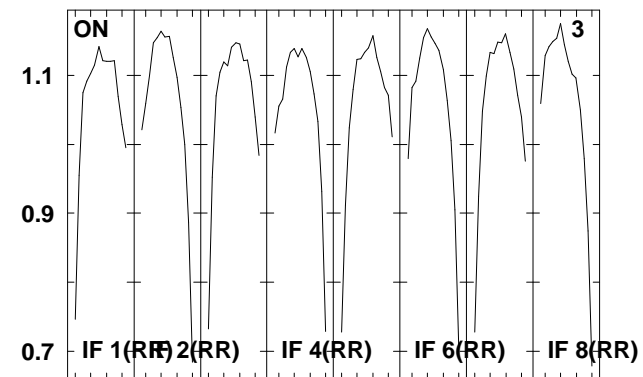
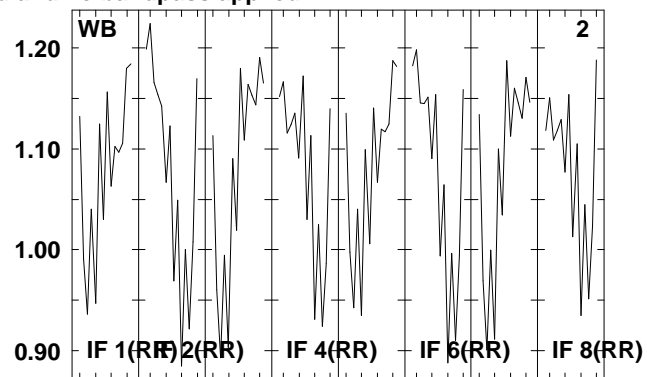
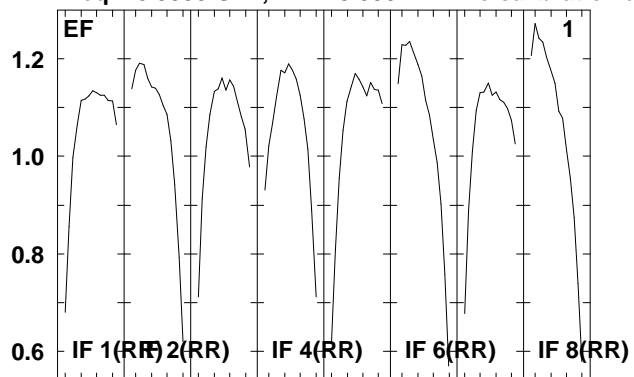

Lower frame: Real Jy  
Total-power spectrum Antenna: \*  
Timerange: 00/18:06:07 to 00/18:07:33

Plot file version 13 created 05-OCT-2009 09:28:17

NGC6240 EH023B 2.UVDATA.1

Freq = 8.3535 GHz, Bw = 8.000 MH No calibration applied and no bandpass applied

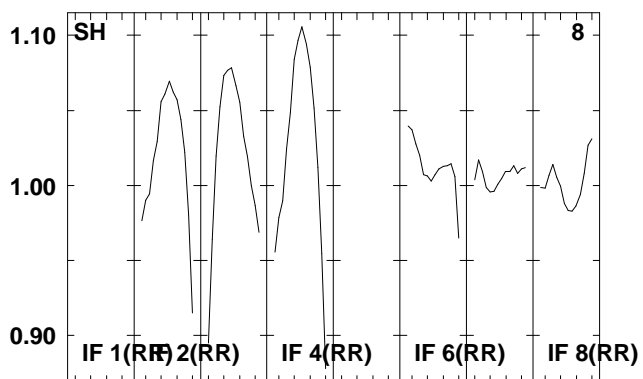
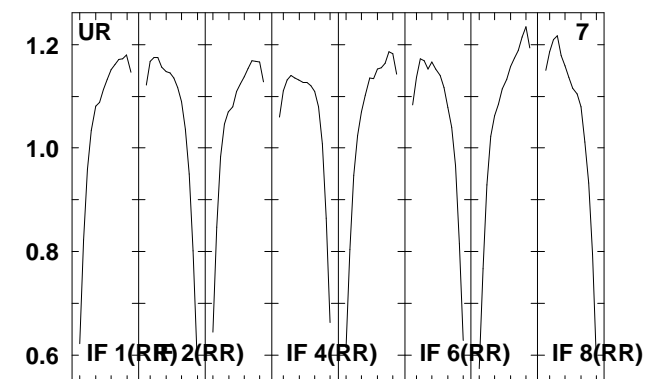
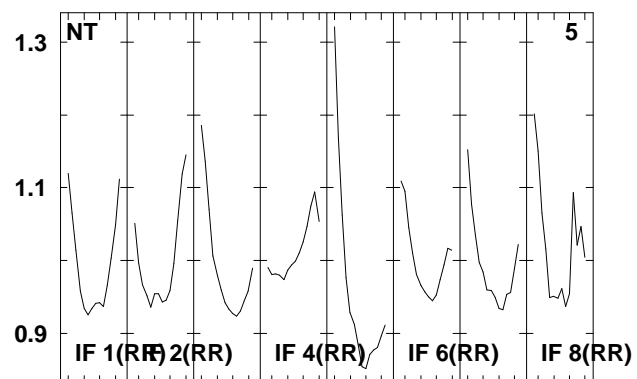
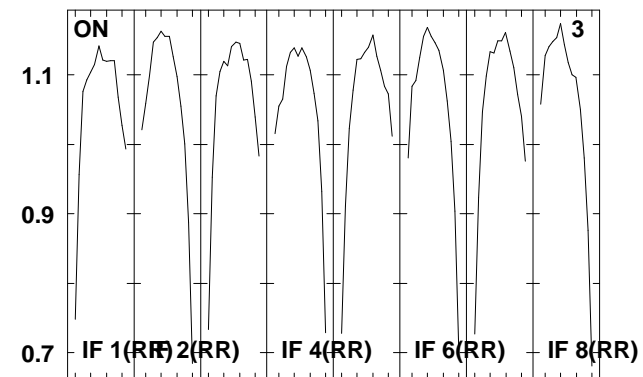
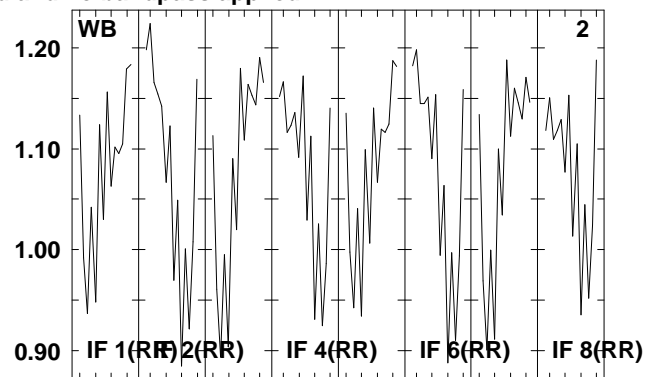
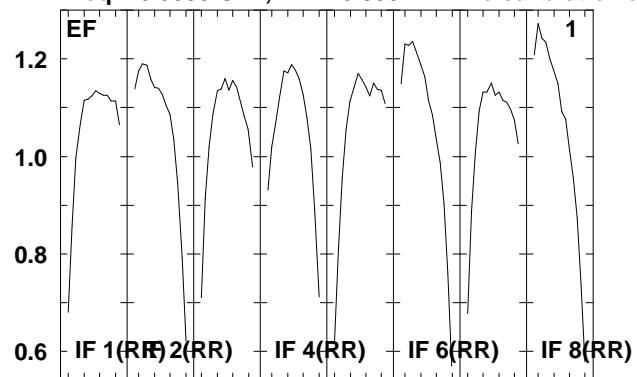

Lower frame: Real Jy  
Total-power spectrum Antenna: \*  
Timerange: 00/18:07:35 to 00/18:11:03

Plot file version 14 created 05-OCT-2009 09:28:18

J1651+01 EH023B 2.UVDATA.1

Freq = 8.3535 GHz, Bw = 8.000 MH No calibration applied and no bandpass applied

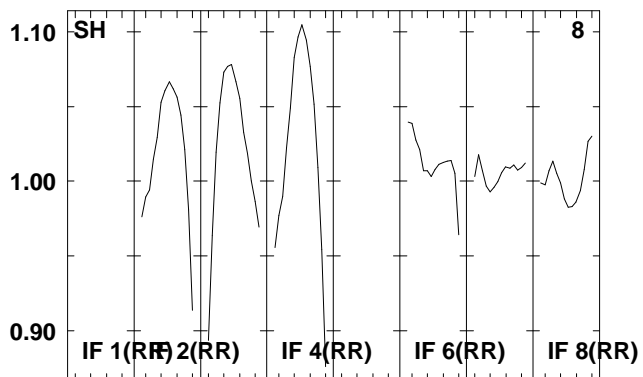
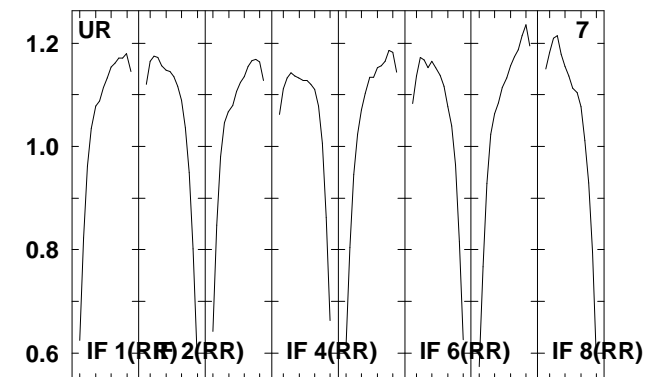
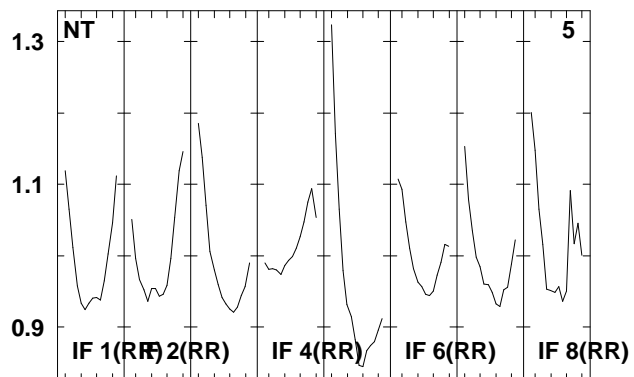
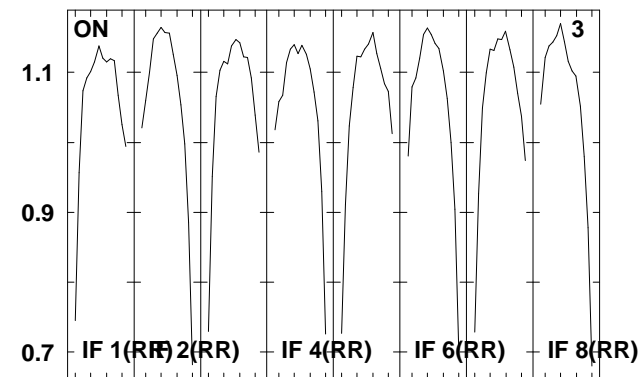
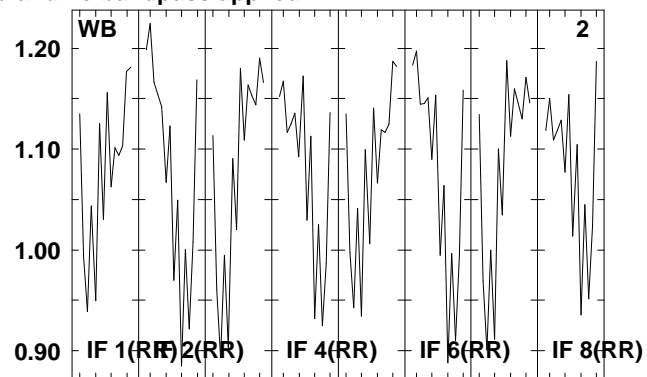
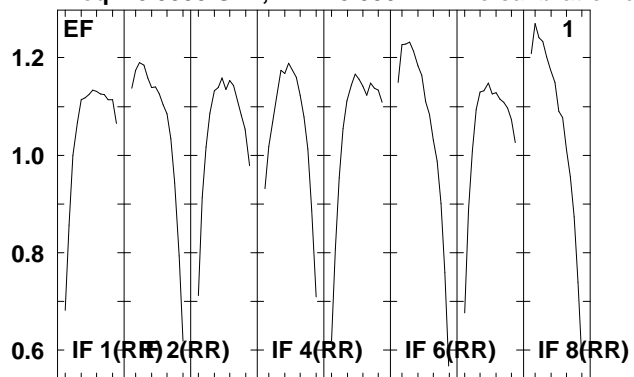

Lower frame: Real Jy  
Total-power spectrum Antenna: \*  
Timerange: 00/18:11:35 to 00/18:13:05

Plot file version 15 created 05-OCT-2009 09:28:18

NGC6240 EH023B 2.UVDATA.1

Freq = 8.3535 GHz, Bw = 8.000 MH No calibration applied and no bandpass applied

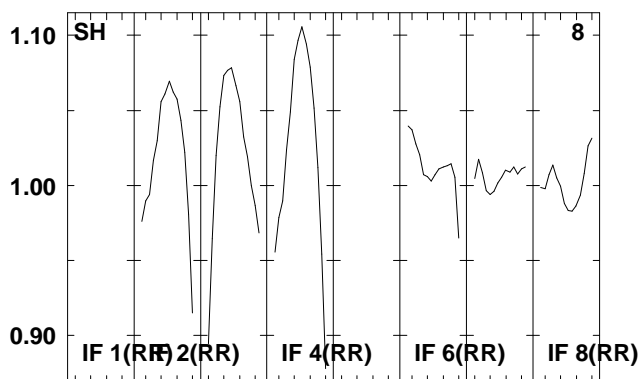
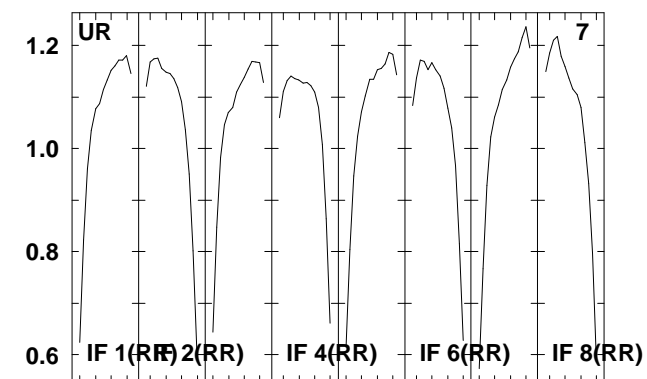
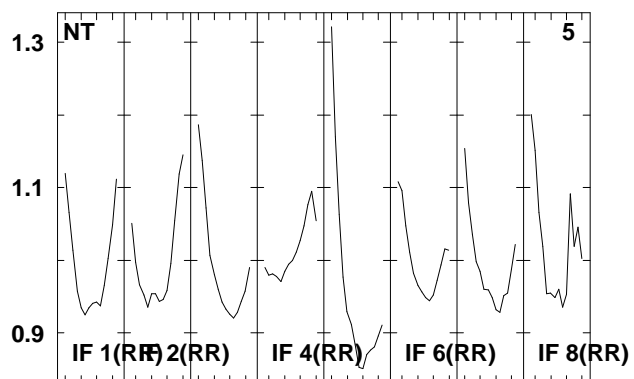
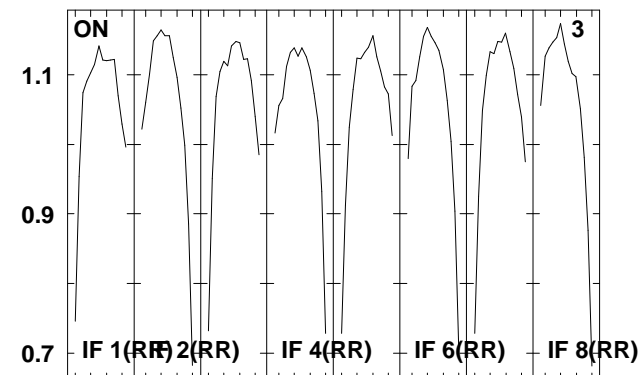
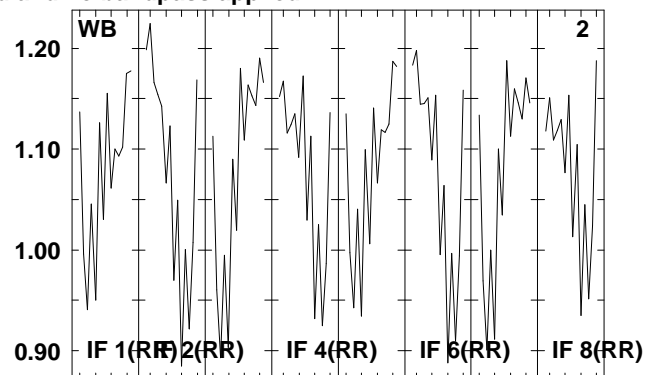
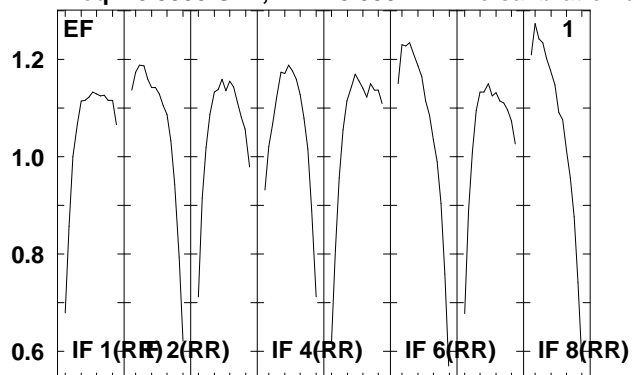

Lower frame: Real Jy  
Total-power spectrum Antenna: \*  
Timerange: 00/18:13:07 to 00/18:16:33

Plot file version 16 created 05-OCT-2009 09:28:18

J1651+01 EH023B 2.UVDATA.1

Freq = 8.3535 GHz, Bw = 8.000 MH No calibration applied and no bandpass applied

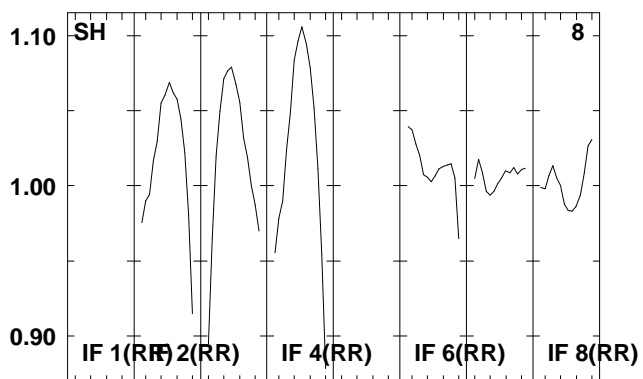
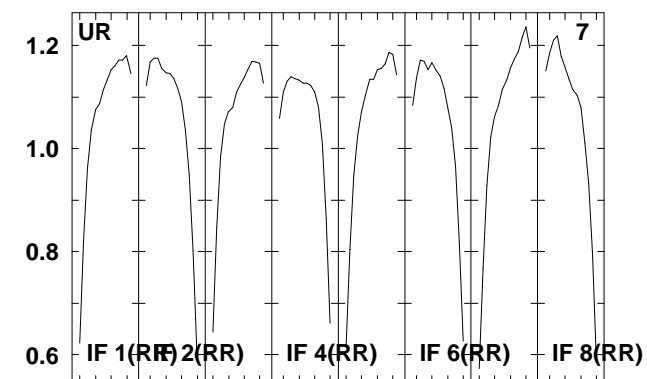
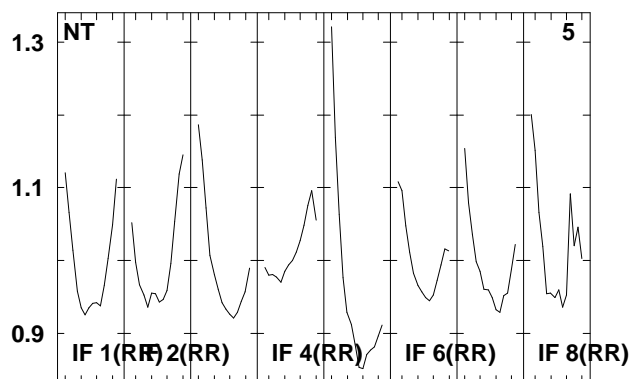
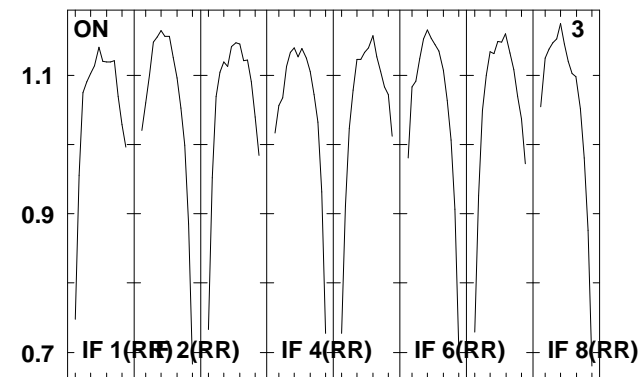
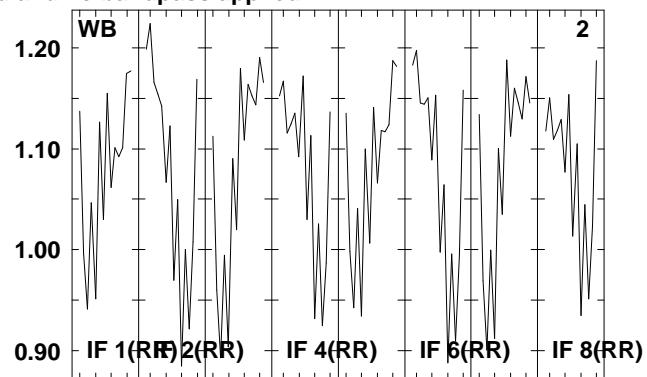
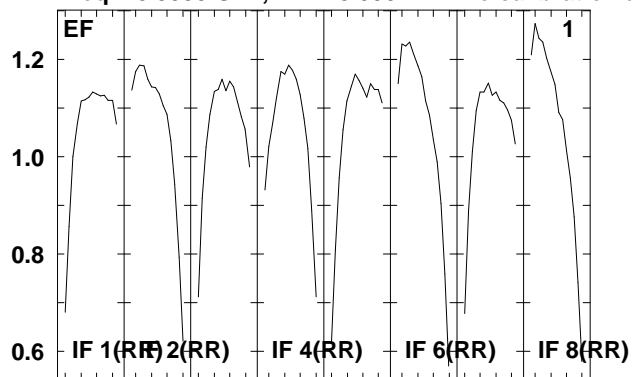

Lower frame: Real Jy  
Total-power spectrum Antenna: \*  
Timerange: 00/18:16:35 to 00/18:18:03



Plot file version 17 created 05-OCT-2009 09:28:18

NGC6240 EH023B 2.UVDATA.1

Freq = 8.3535 GHz, Bw = 8.000 MH No calibration applied and no bandpass applied

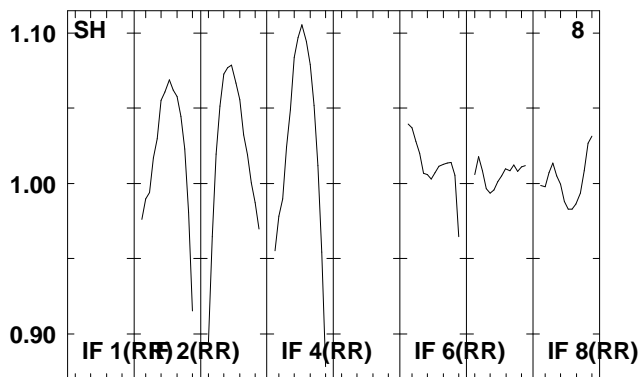
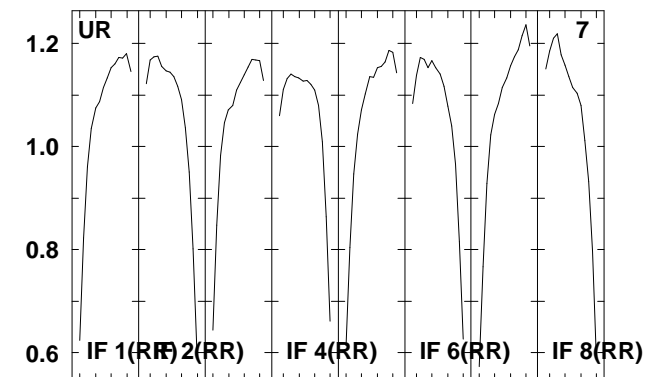
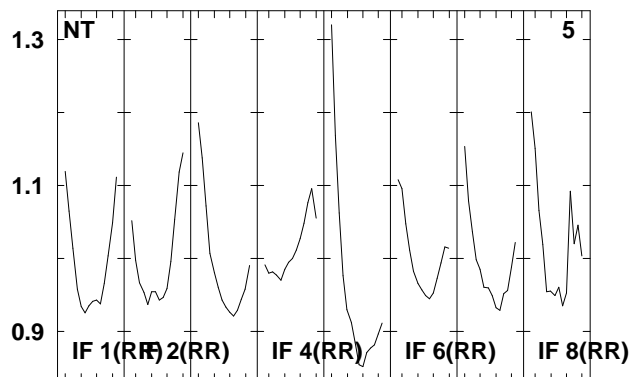
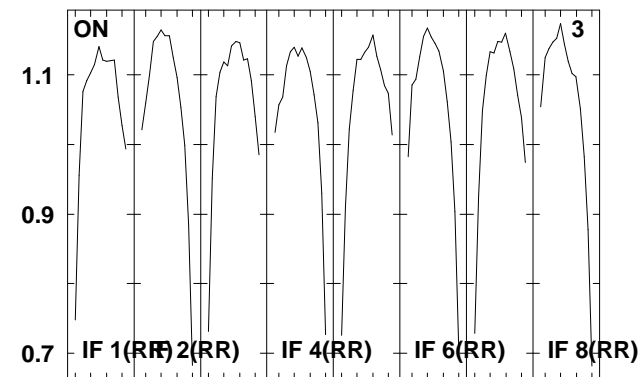
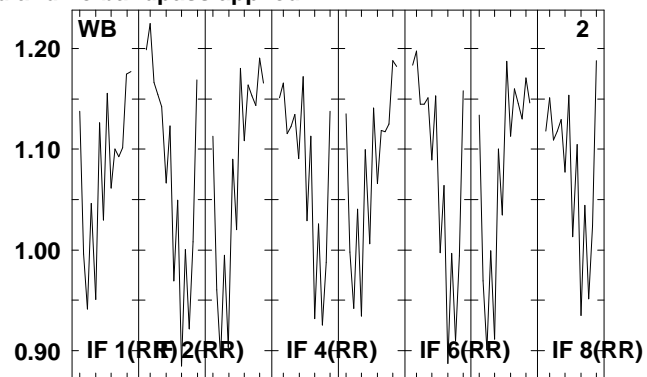
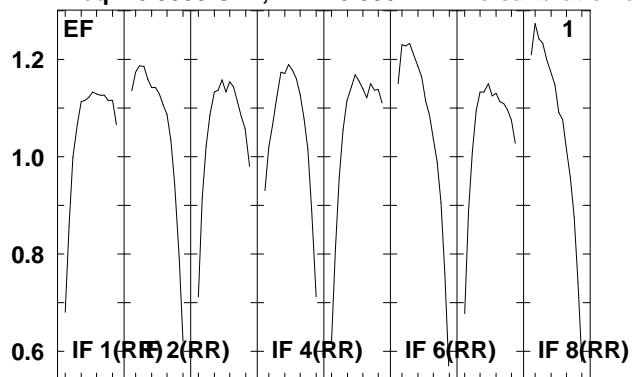

Lower frame: Real Jy  
Total-power spectrum Antenna: \*  
Timerange: 00/18:18:05 to 00/18:21:35

Plot file version 18 created 05-OCT-2009 09:28:18

J1651+01 EH023B 2.UVDATA.1

Freq = 8.3535 GHz, Bw = 8.000 MH No calibration applied and no bandpass applied

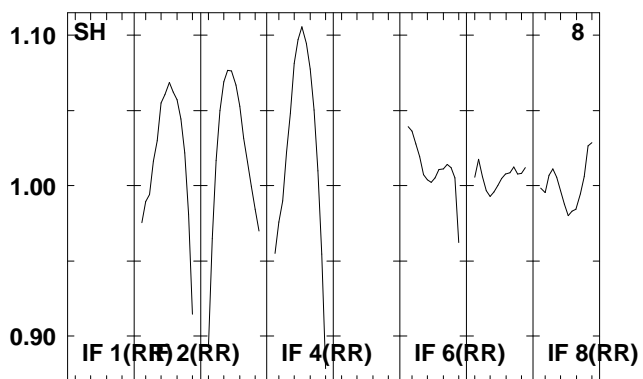
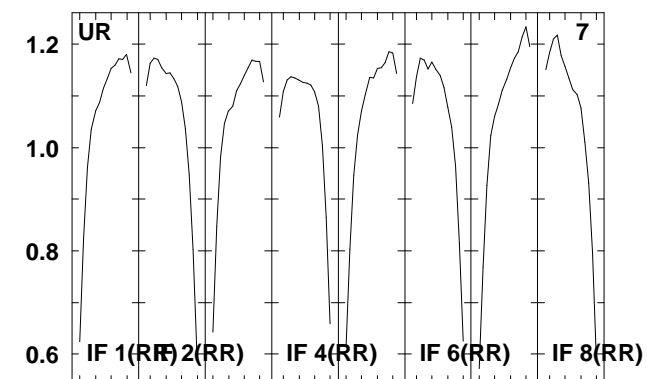
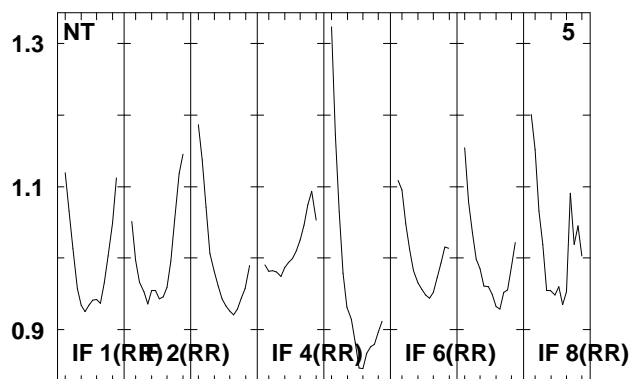
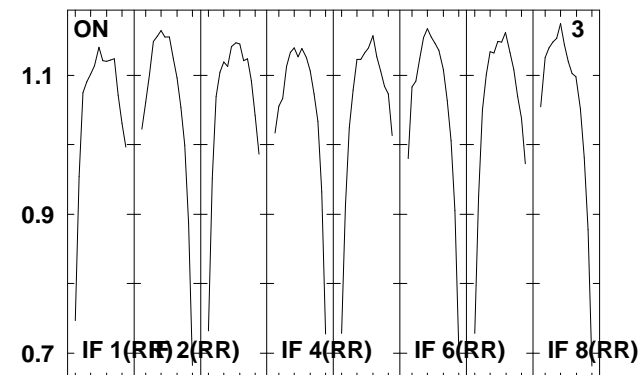
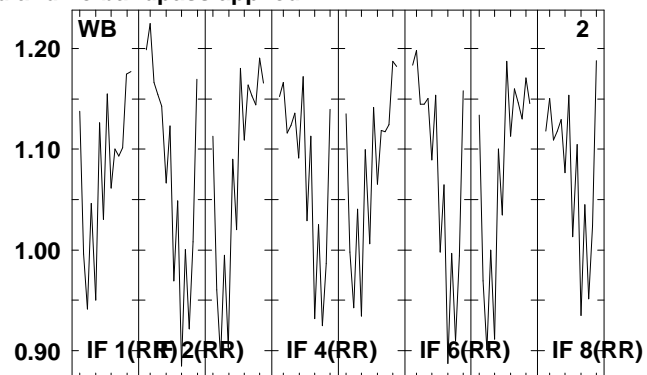
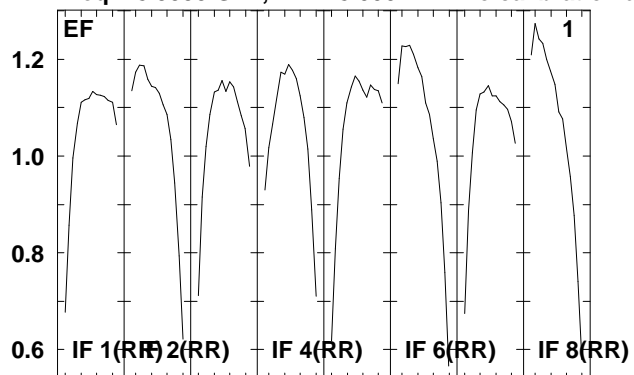

Lower frame: Real Jy  
Total-power spectrum Antenna: \*  
Timerange: 00/18:22:07 to 00/18:23:33

Plot file version 19 created 05-OCT-2009 09:28:18

NGC6240 EH023B 2.UVDATA.1

Freq = 8.3535 GHz, Bw = 8.000 MH No calibration applied and no bandpass applied

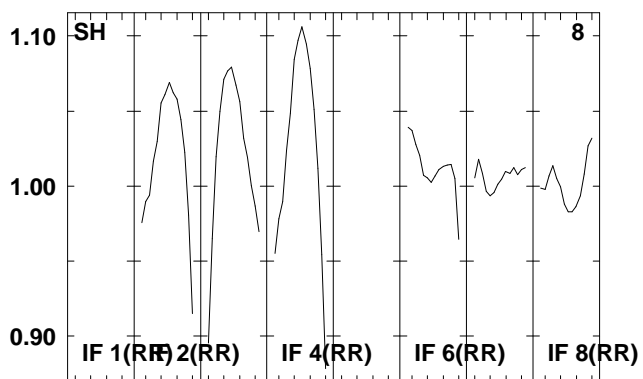
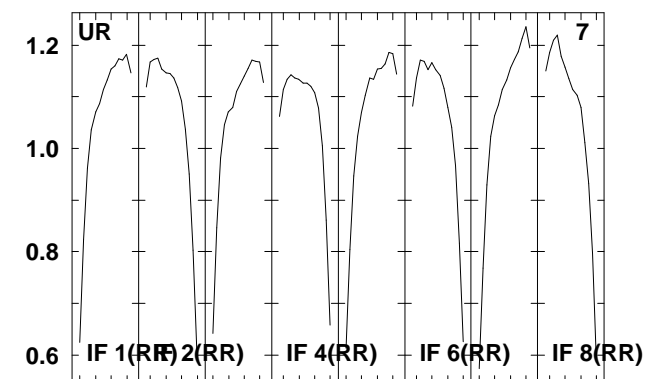
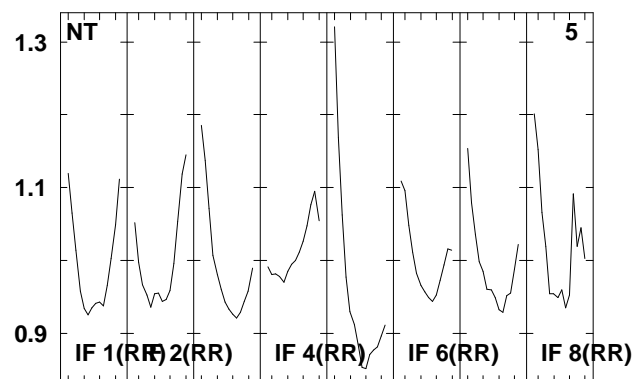
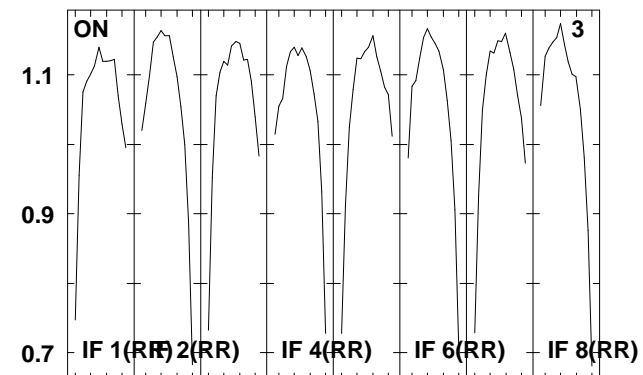
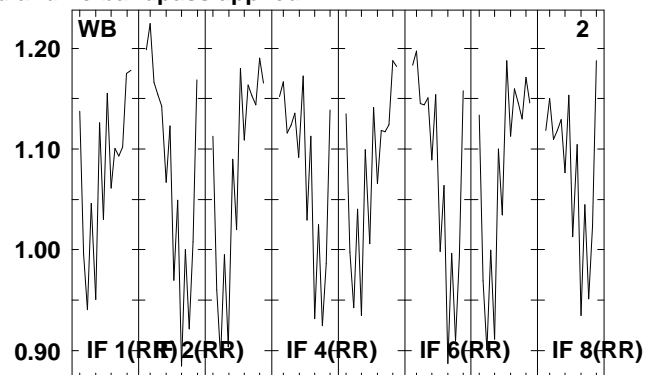
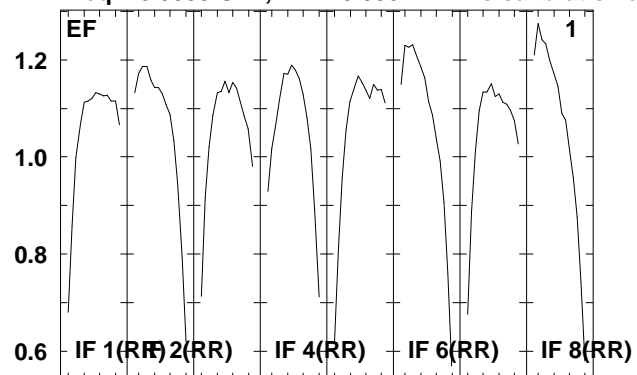

Lower frame: Real Jy  
Total-power spectrum Antenna: \*  
Timerange: 00/18:23:35 to 00/18:27:03

Plot file version 20 created 05-OCT-2009 09:28:19

J1651+01 EH023B 2.UVDATA.1

Freq = 8.3535 GHz, Bw = 8.000 MH No calibration applied and no bandpass applied

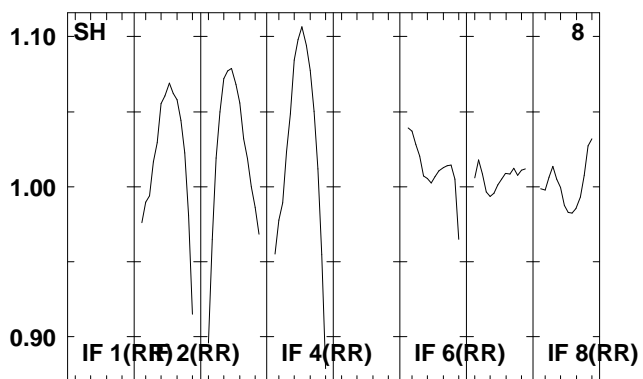
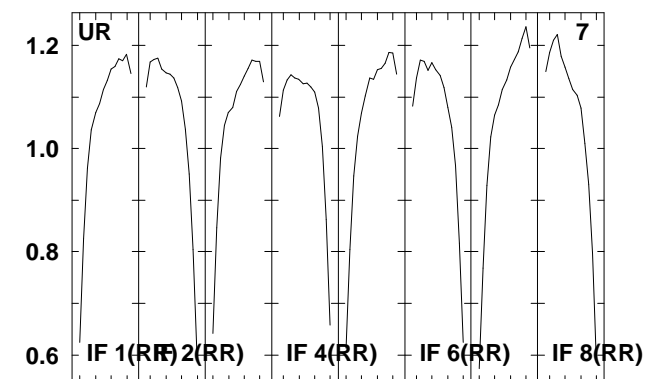
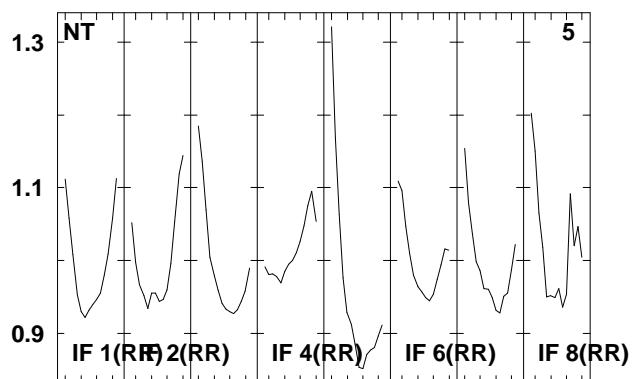
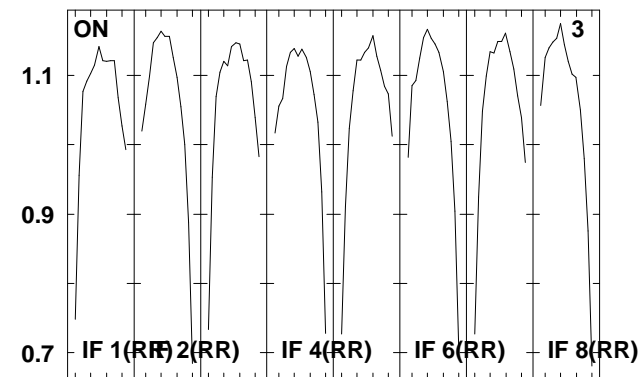
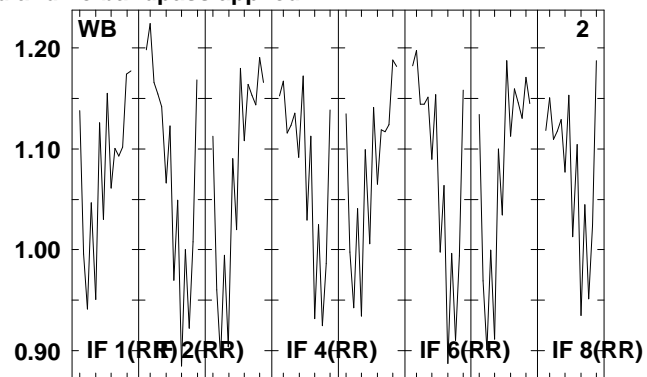
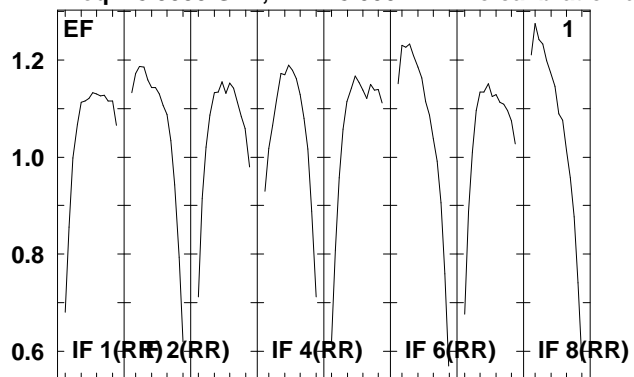

Lower frame: Real Jy  
Total-power spectrum Antenna: \*  
Timerange: 00/18:27:05 to 00/18:28:35

Plot file version 21 created 05-OCT-2009 09:28:19

NGC6240 EH023B 2.UVDATA.1

Freq = 8.3535 GHz, Bw = 8.000 MH No calibration applied and no bandpass applied

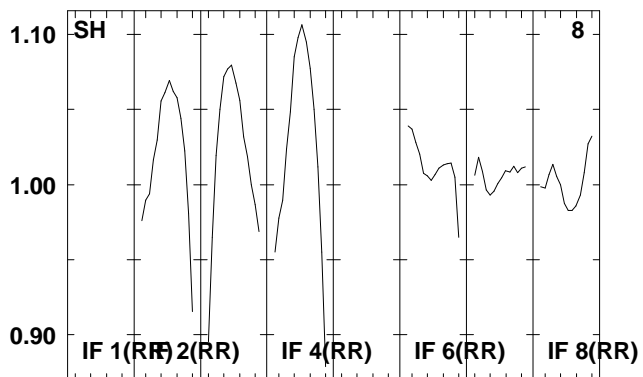
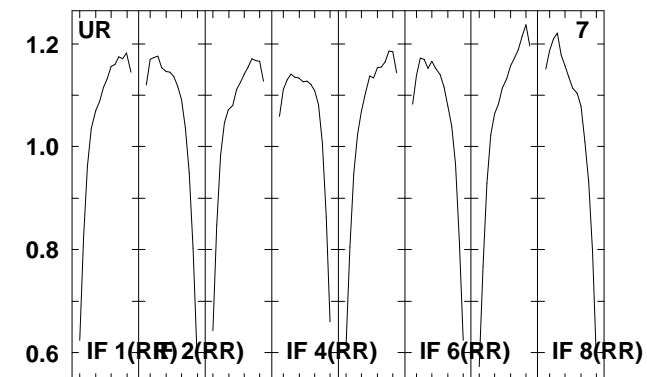
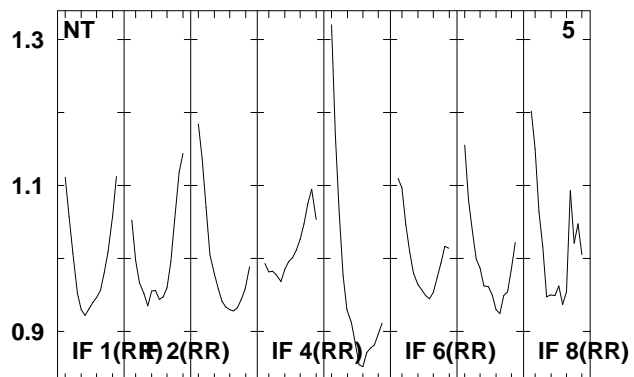
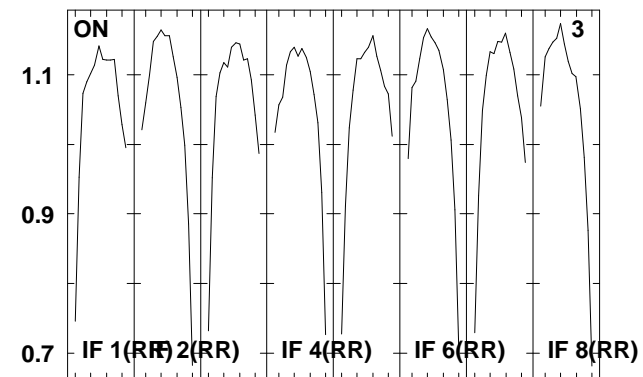
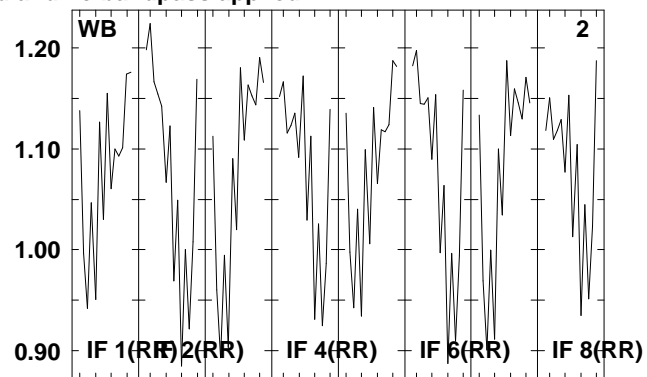
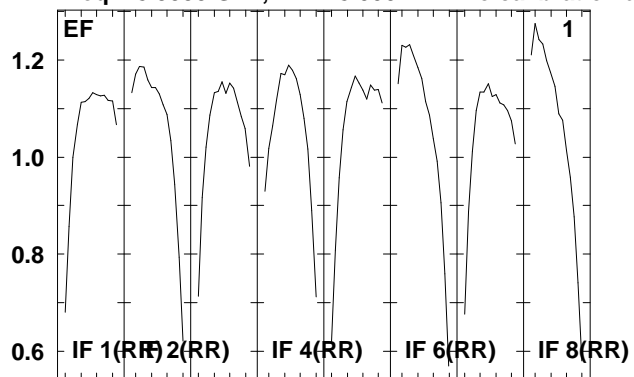

Lower frame: Real Jy  
Total-power spectrum Antenna: \*  
Timerange: 00/18:28:37 to 00/18:32:03

Plot file version 22 created 05-OCT-2009 09:28:19

J1651+01 EH023B 2.UVDATA.1

Freq = 8.3535 GHz, Bw = 8.000 MH No calibration applied and no bandpass applied

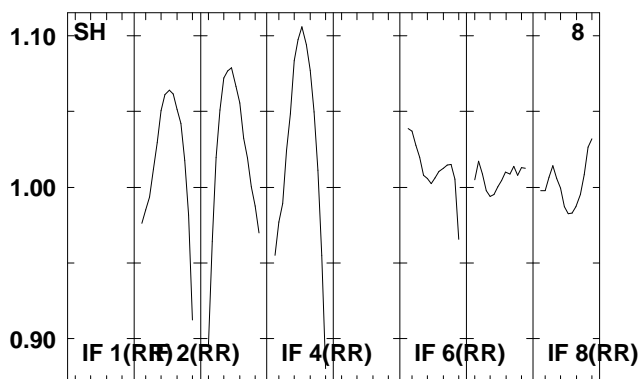
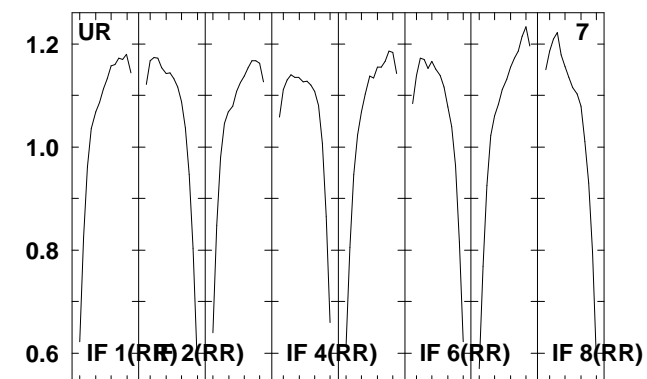
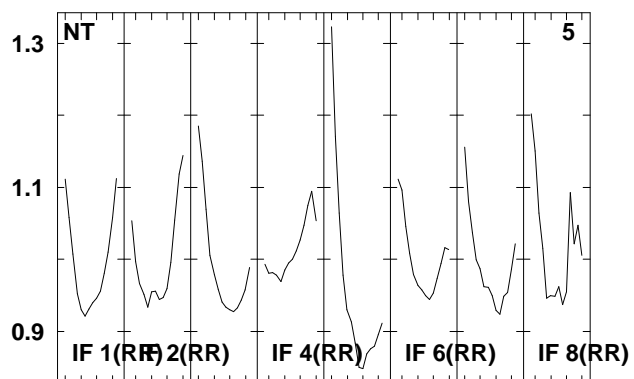
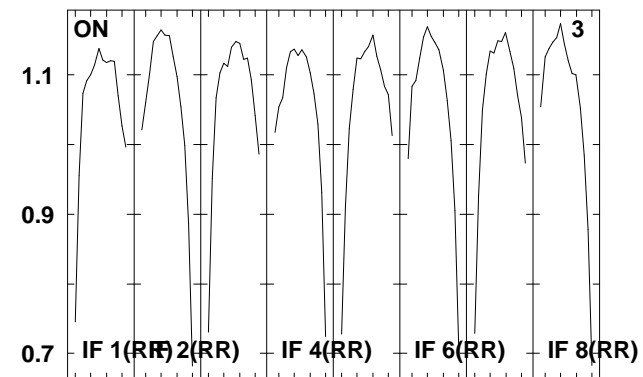
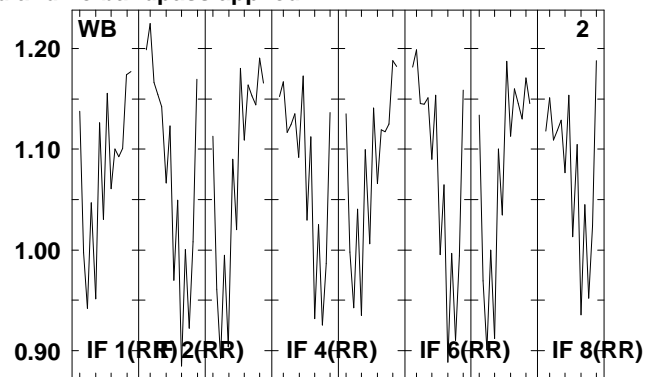
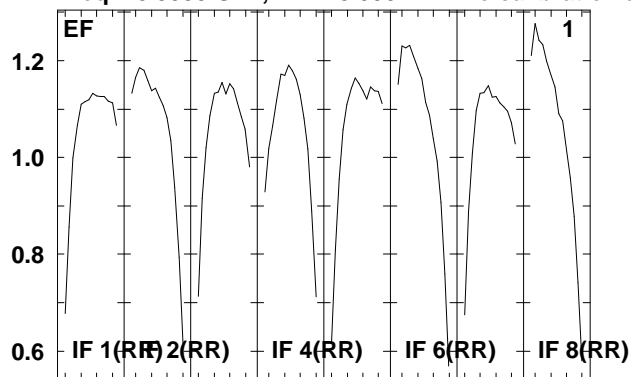

Lower frame: Real Jy  
Total-power spectrum Antenna: \*  
Timerange: 00/18:32:35 to 00/18:34:03

Plot file version 23 created 05-OCT-2009 09:28:19

NGC6240 EH023B 2.UVDATA.1

Freq = 8.3535 GHz, Bw = 8.000 MH No calibration applied and no bandpass applied

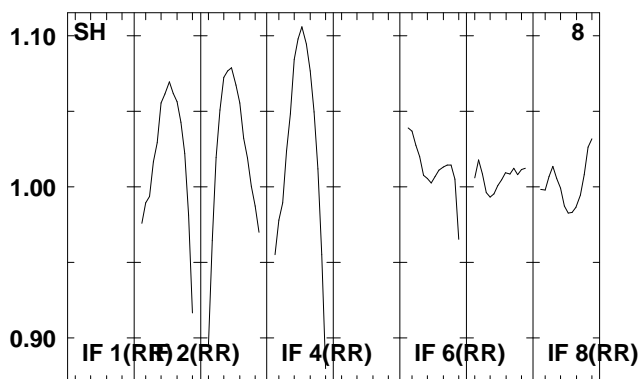
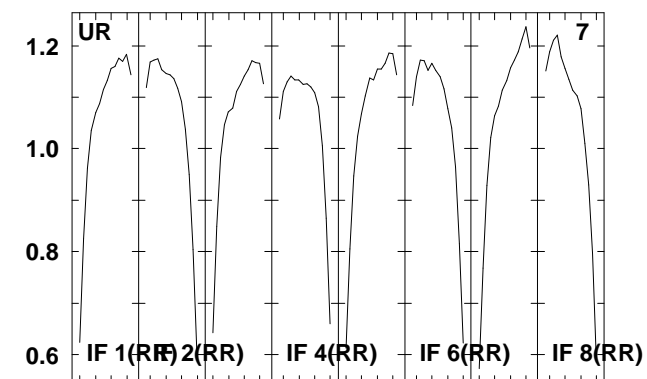
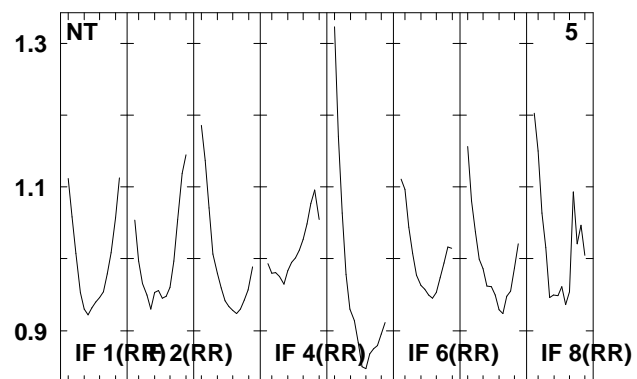
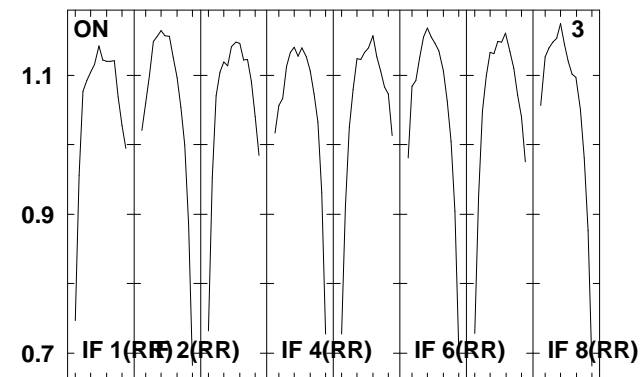
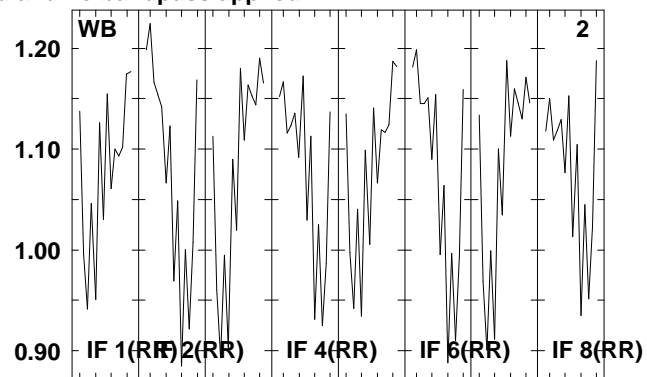
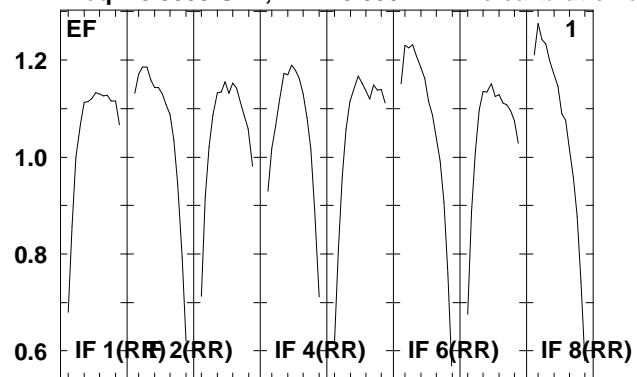

Lower frame: Real Jy  
Total-power spectrum Antenna: \*  
Timerange: 00/18:34:05 to 00/18:37:35

Plot file version 24 created 05-OCT-2009 09:28:19

J1651+01 EH023B 2.UVDATA.1

Freq = 8.3535 GHz, Bw = 8.000 MH No calibration applied and no bandpass applied

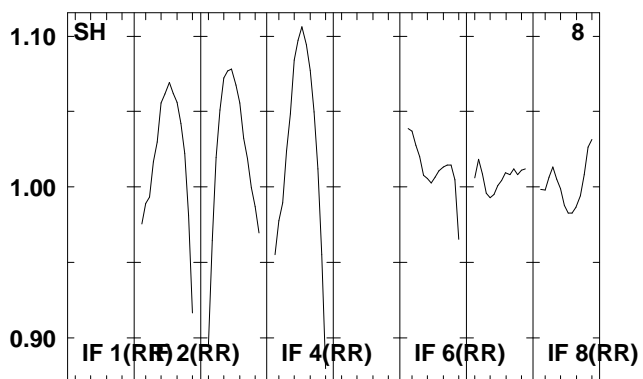
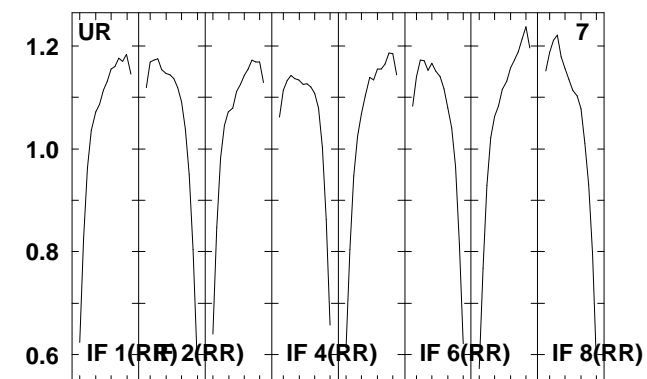
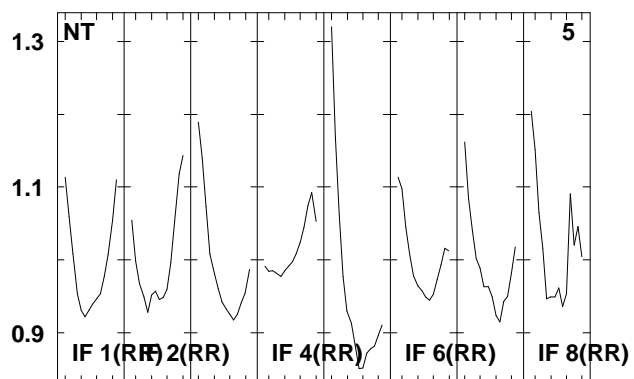
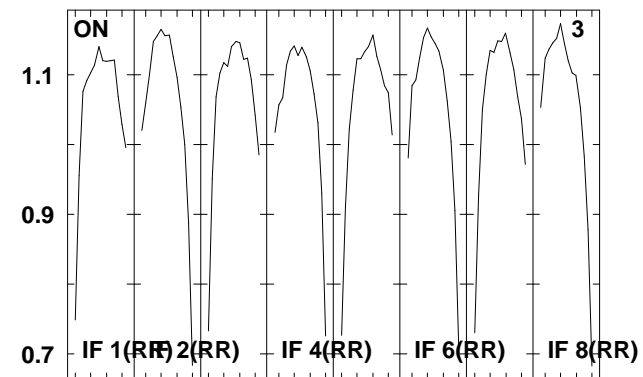
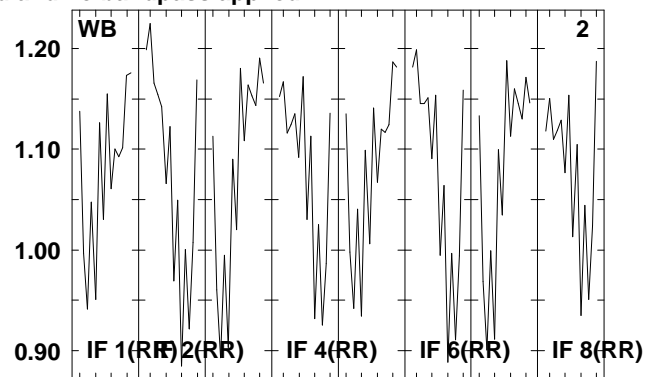
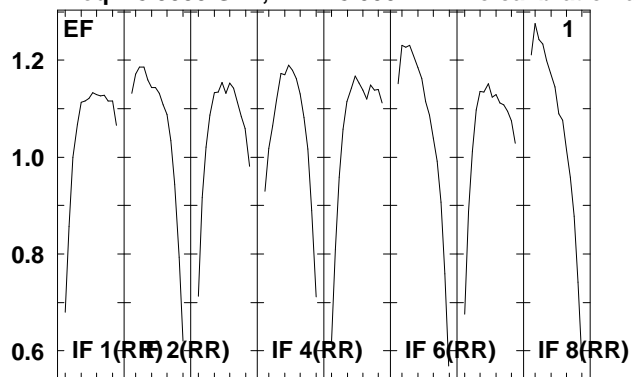

Lower frame: Real Jy  
Total-power spectrum Antenna: \*  
Timerange: 00/18:37:37 to 00/18:39:03



Plot file version 25 created 05-OCT-2009 09:28:19

NGC6240 EH023B 2.UVDATA.1

Freq = 8.3535 GHz, Bw = 8.000 MH No calibration applied and no bandpass applied

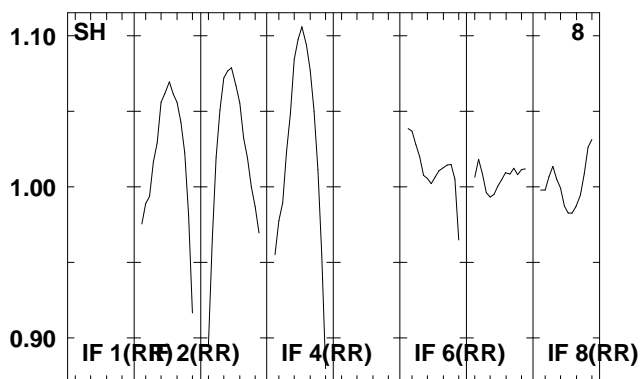
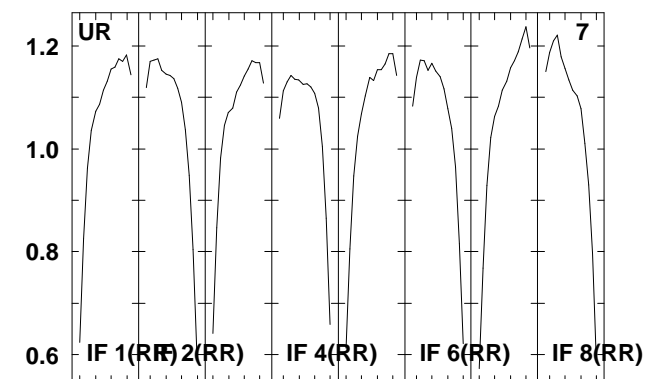
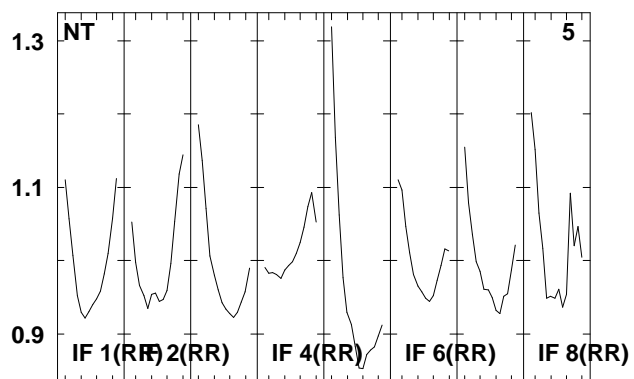
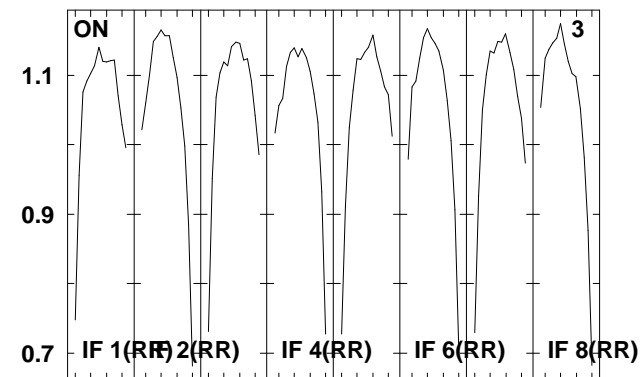
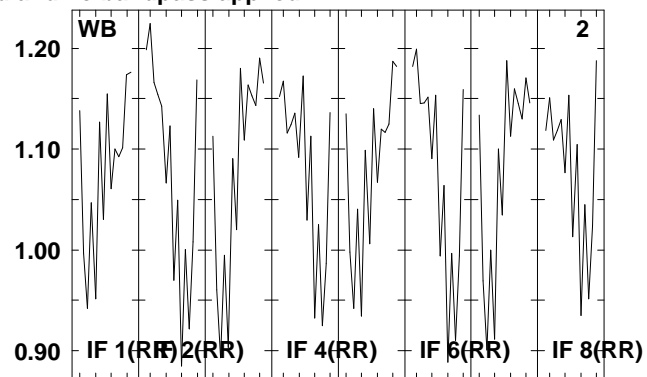
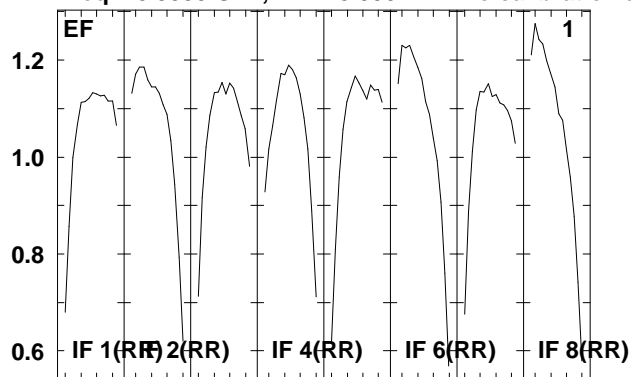

Lower frame: Real Jy  
Total-power spectrum Antenna: \*  
Timerange: 00/18:39:05 to 00/18:42:33

Plot file version 26 created 05-OCT-2009 09:28:20

J1651+01 EH023B 2.UVDATA.1

Freq = 8.3535 GHz, Bw = 8.000 MH No calibration applied and no bandpass applied

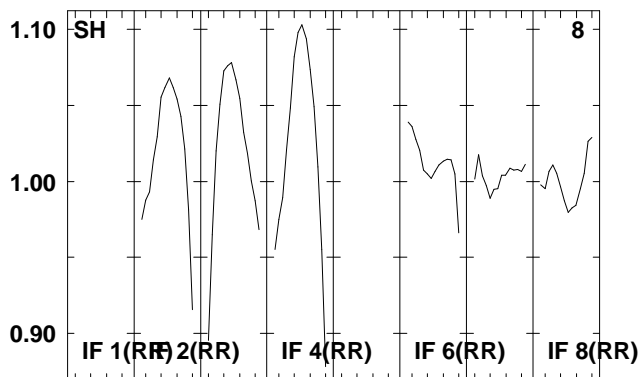
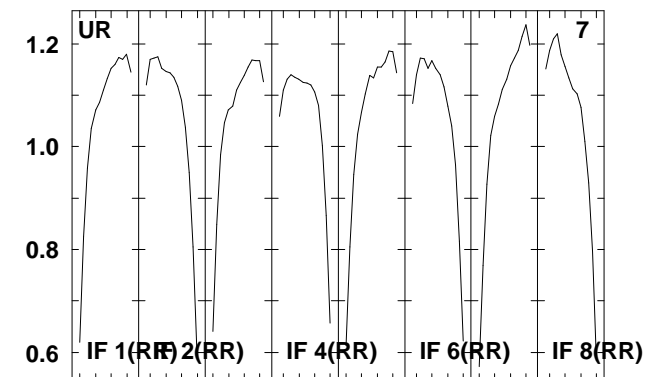
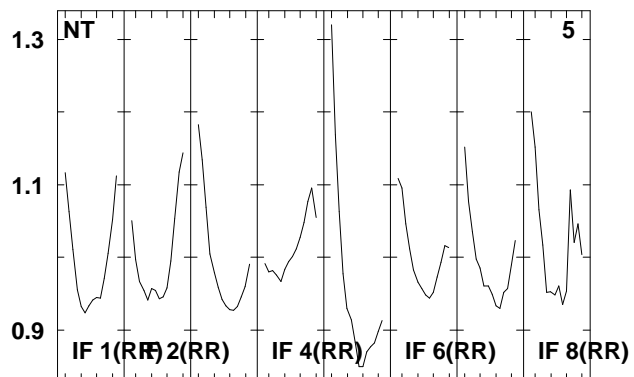
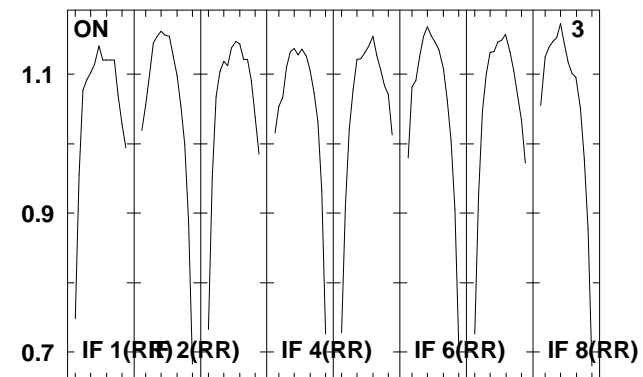
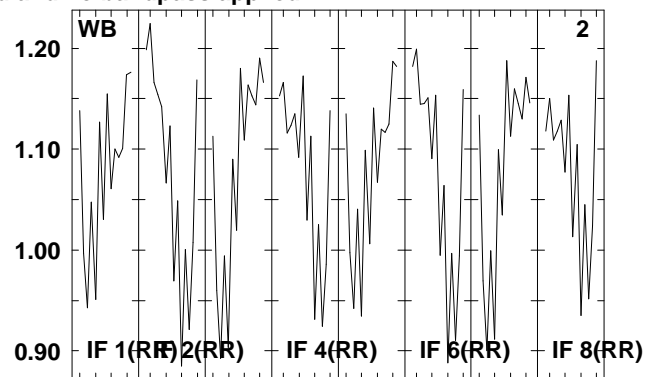
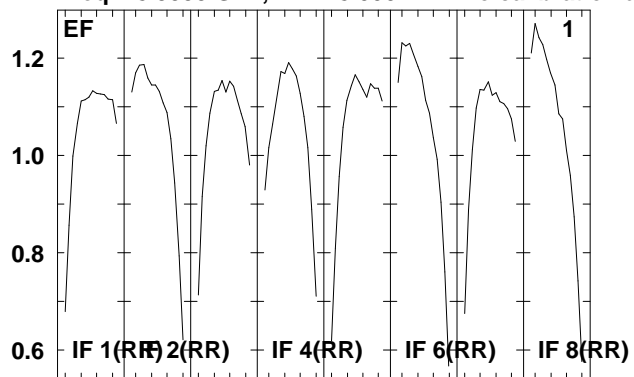

Lower frame: Real Jy  
Total-power spectrum Antenna: \*  
Timerange: 00/18:43:05 to 00/18:44:35

Plot file version 27 created 05-OCT-2009 09:28:20

NGC6240 EH023B 2.UVDATA.1

Freq = 8.3535 GHz, Bw = 8.000 MH No calibration applied and no bandpass applied

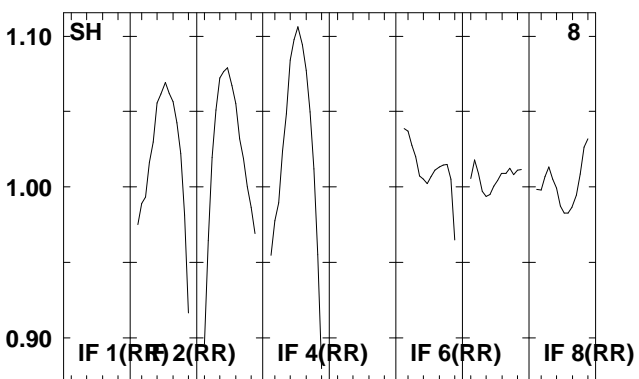
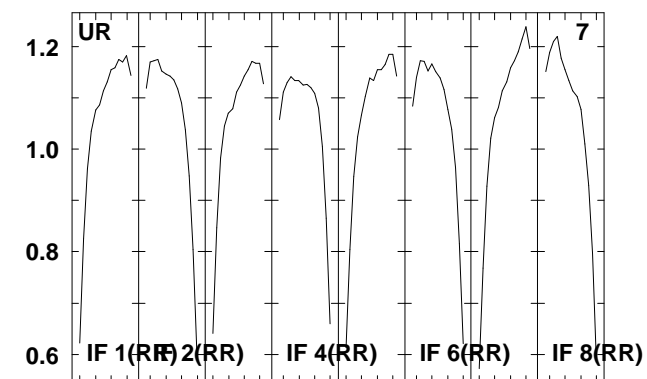
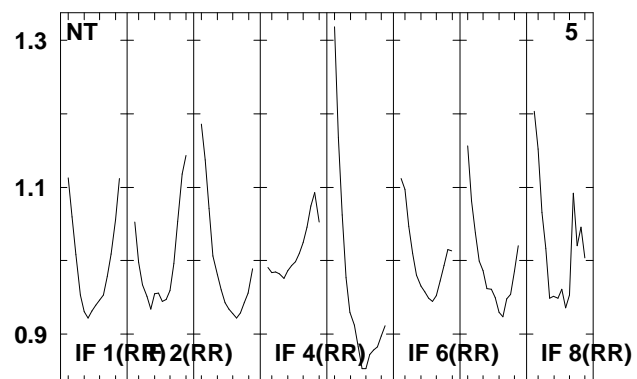
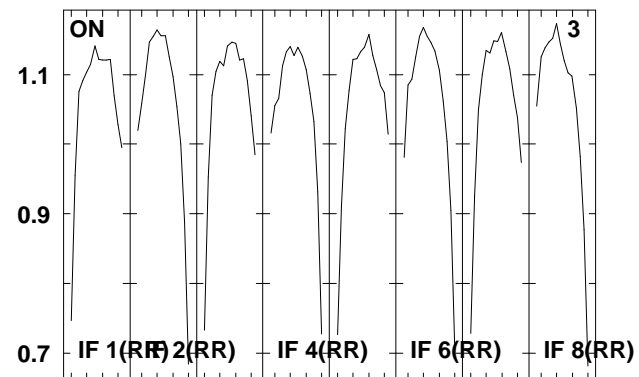
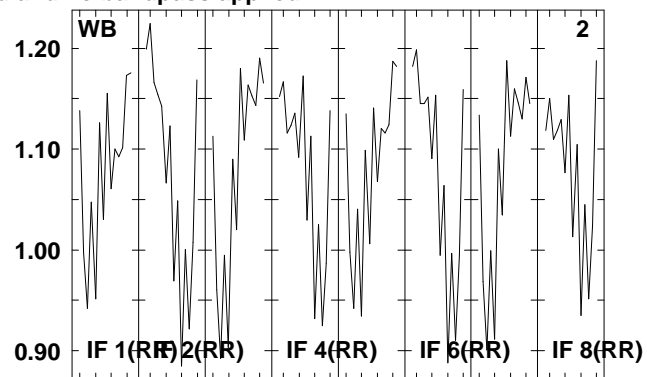
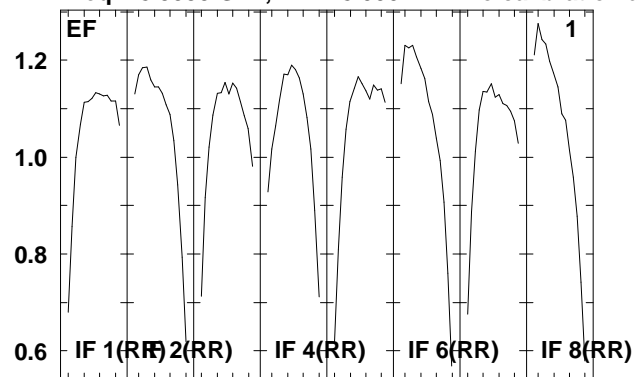

Lower frame: Real Jy  
Total-power spectrum Antenna: \*  
Timerange: 00/18:44:37 to 00/18:48:03

Plot file version 28 created 05-OCT-2009 09:28:20

J1651+01 EH023B 2.UVDATA.1

Freq = 8.3535 GHz, Bw = 8.000 MH No calibration applied and no bandpass applied

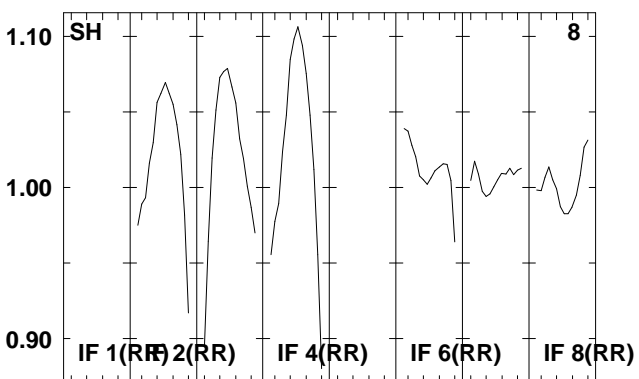
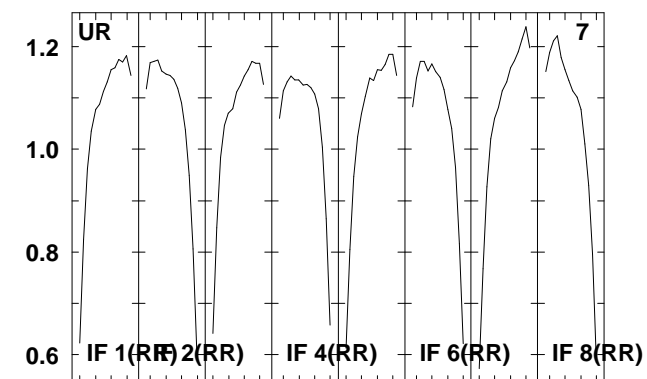
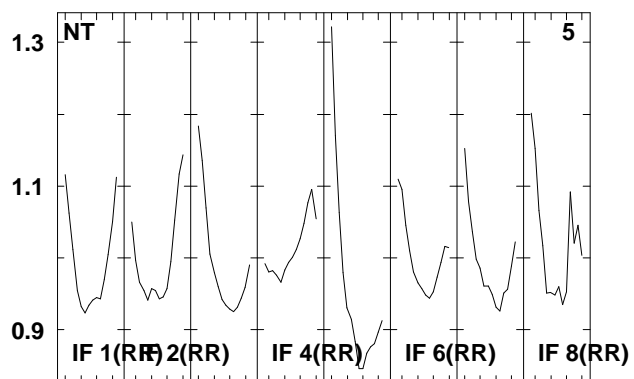
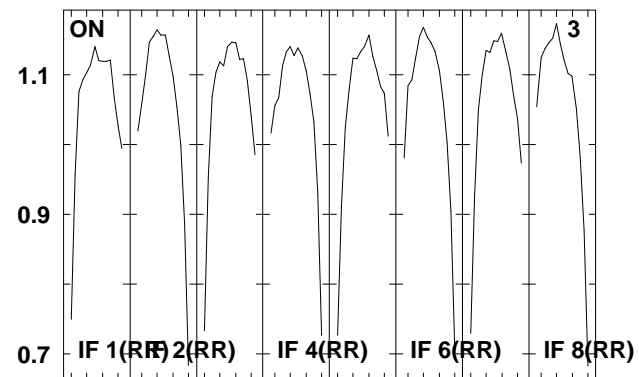
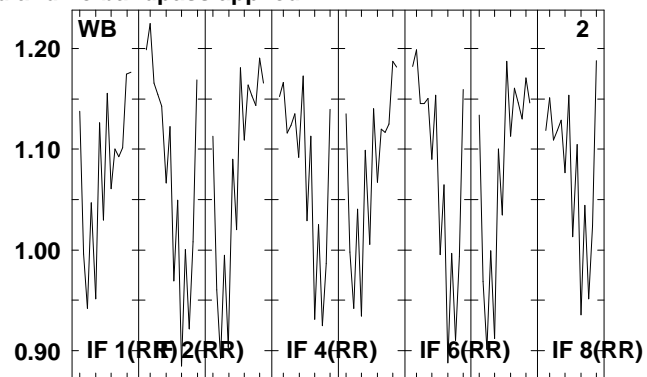
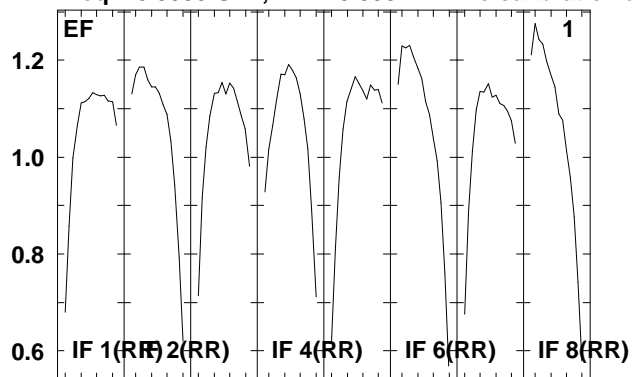

Lower frame: Real Jy  
Total-power spectrum Antenna: \*  
Timerange: 00/18:48:05 to 00/18:49:33

Plot file version 29 created 05-OCT-2009 09:28:20

NGC6240 EH023B 2.UVDATA.1

Freq = 8.3535 GHz, Bw = 8.000 MH No calibration applied and no bandpass applied

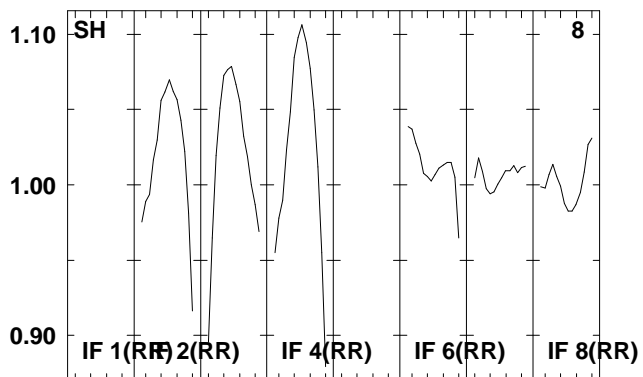
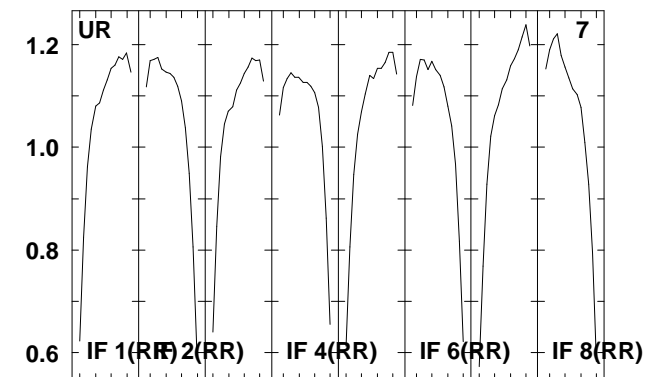
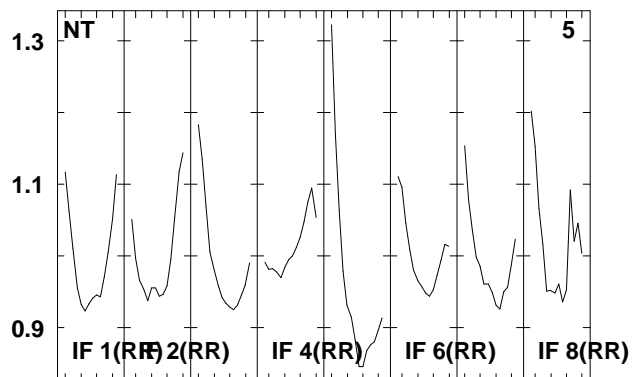
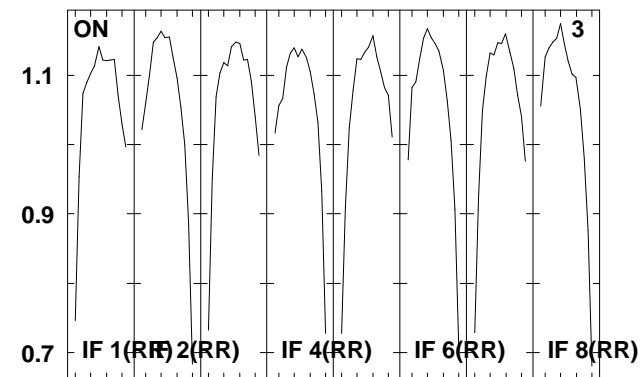
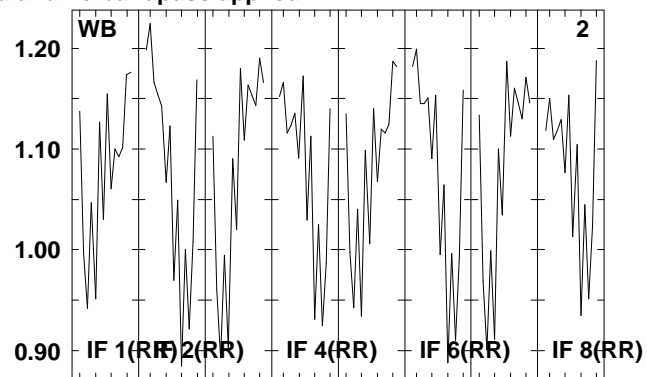
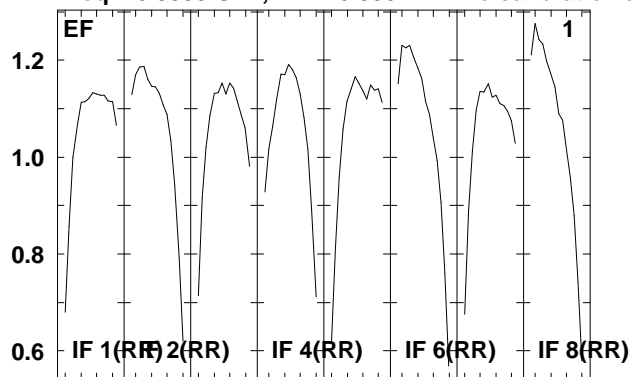

Lower frame: Real Jy  
Total-power spectrum Antenna: \*  
Timerange: 00/18:49:35 to 00/18:53:03

Plot file version 30 created 05-OCT-2009 09:28:20

J1651+01 EH023B 2.UVDATA.1

Freq = 8.3535 GHz, Bw = 8.000 MH No calibration applied and no bandpass applied

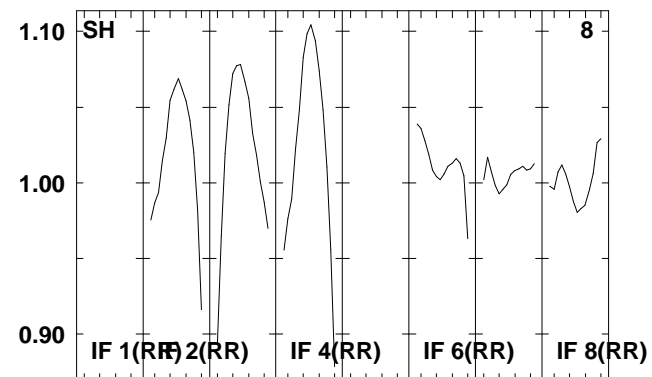
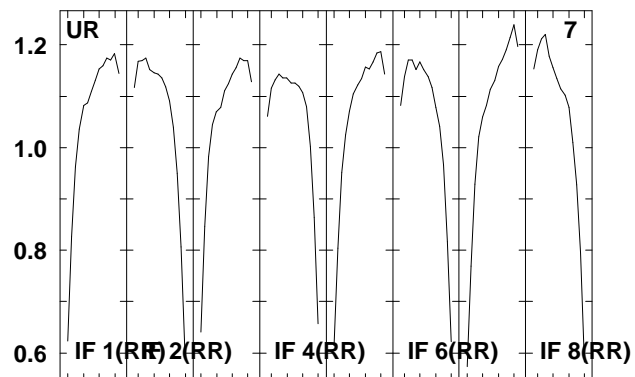
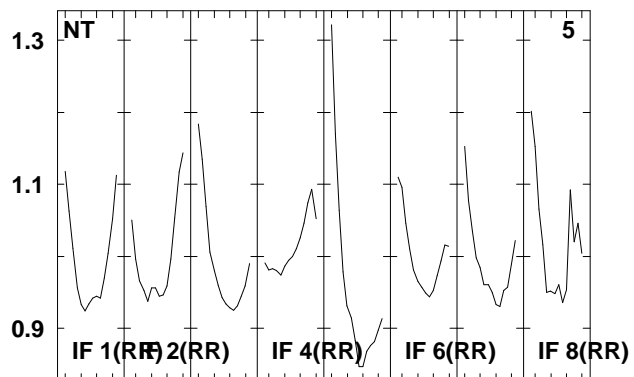
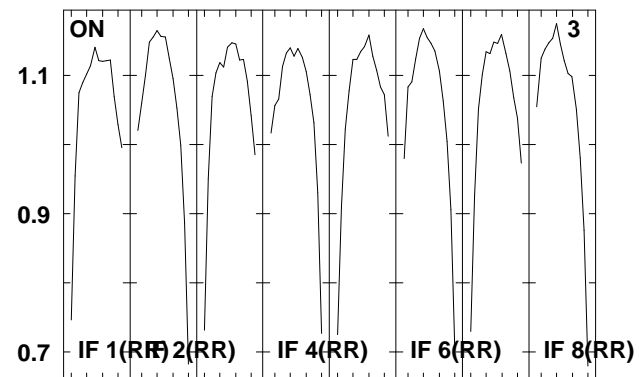
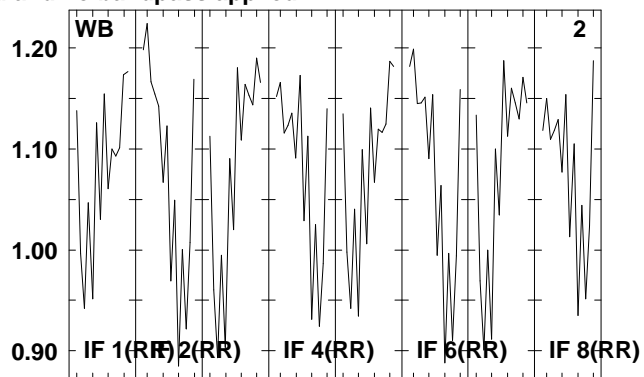
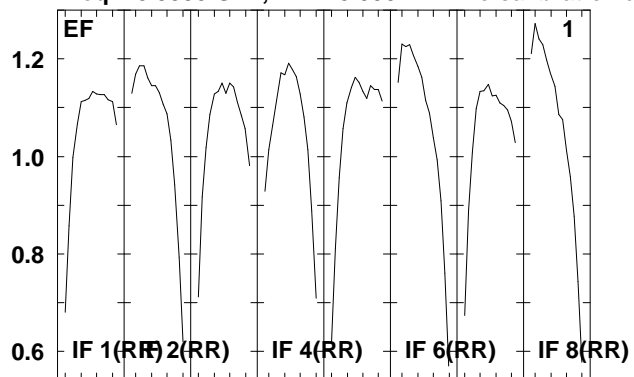

Lower frame: Real Jy  
Total-power spectrum Antenna: \*  
Timerange: 00/18:53:37 to 00/18:55:03

Plot file version 31 created 05-OCT-2009 09:28:20

NGC6240 EH023B 2.UVDATA.1

Freq = 8.3535 GHz, Bw = 8.000 MH No calibration applied and no bandpass applied

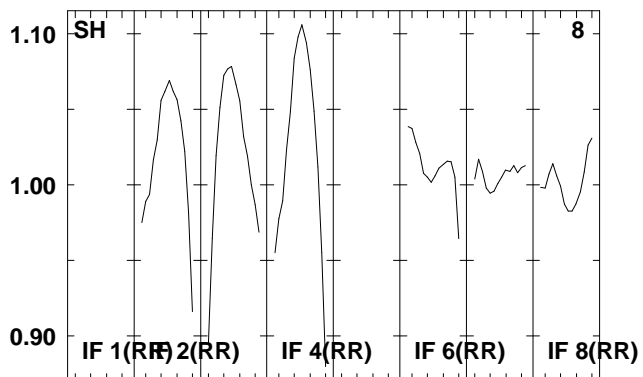
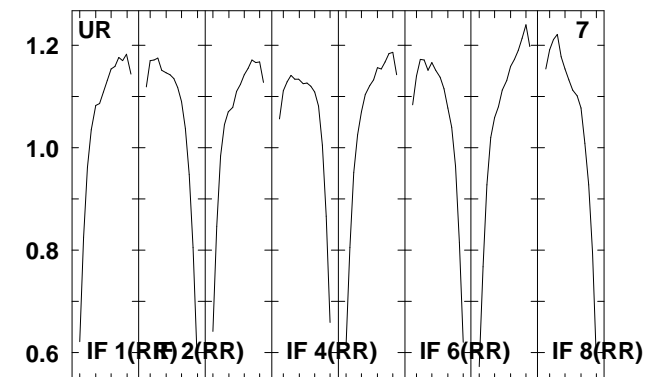
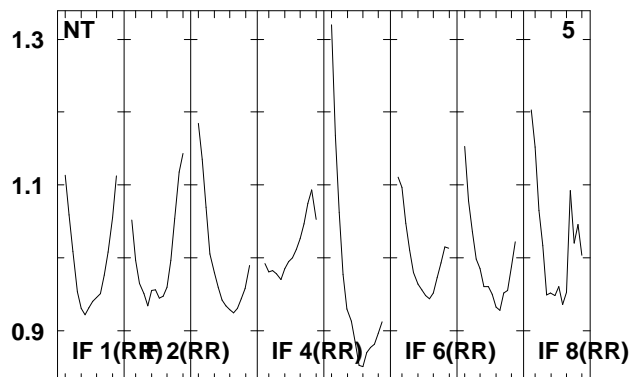
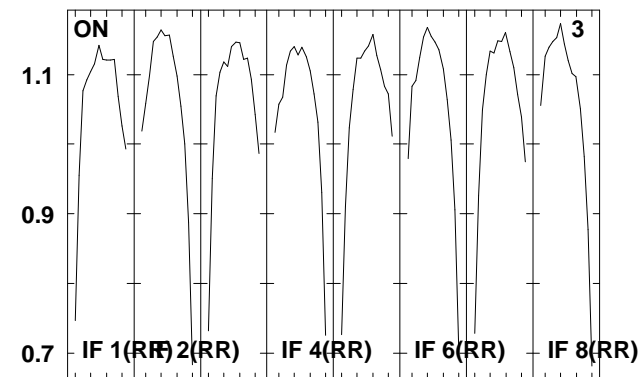
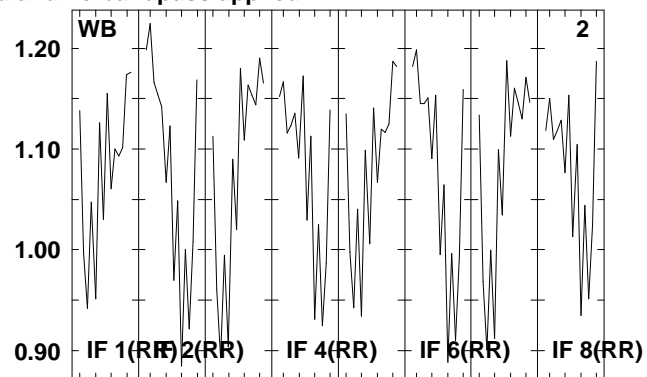
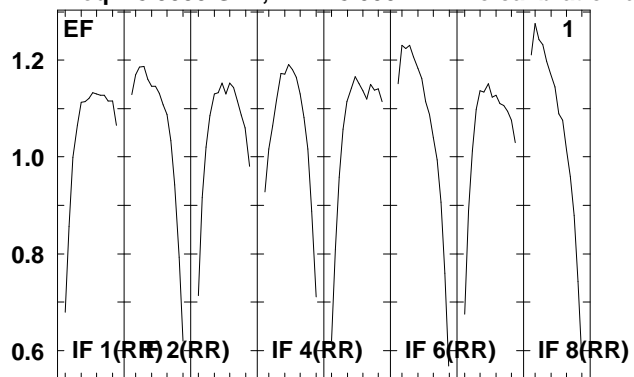

Lower frame: Real Jy  
Total-power spectrum Antenna: \*  
Timerange: 00/18:55:05 to 00/18:58:33

Plot file version 32 created 05-OCT-2009 09:28:20

J1651+01 EH023B 2.UVDATA.1

Freq = 8.3535 GHz, Bw = 8.000 MH No calibration applied and no bandpass applied

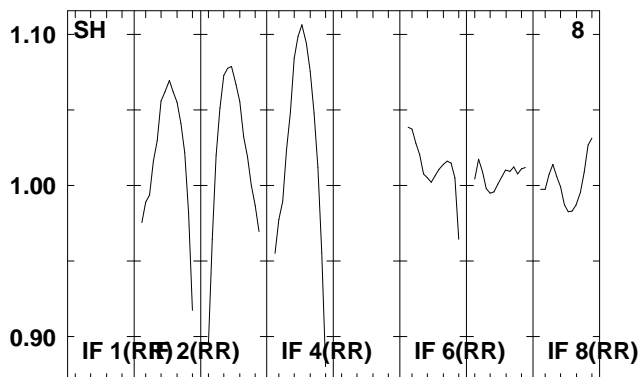
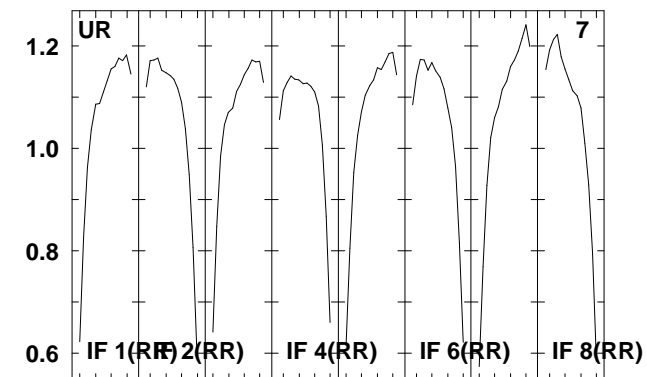
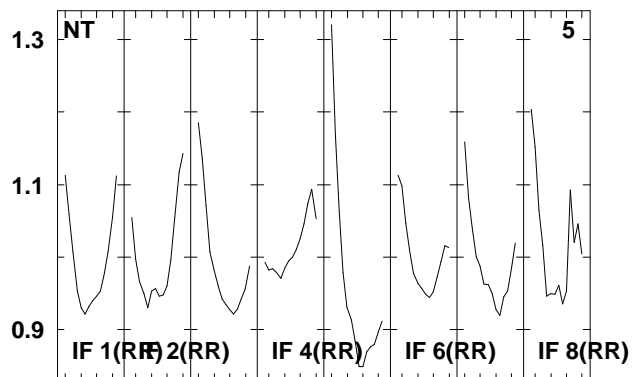
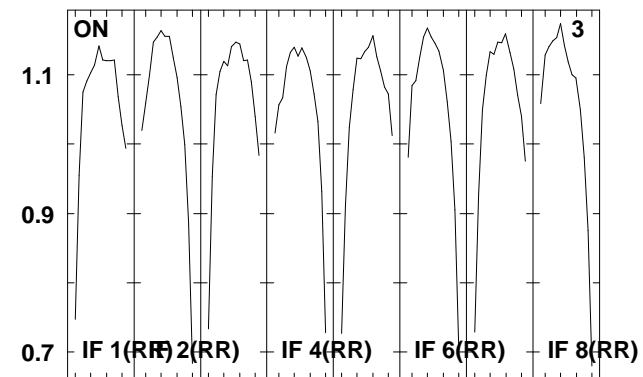
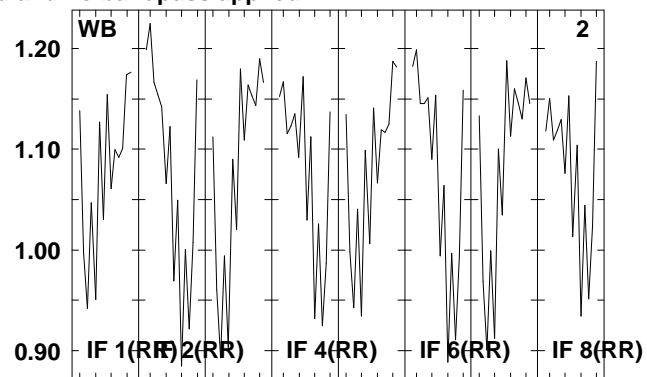
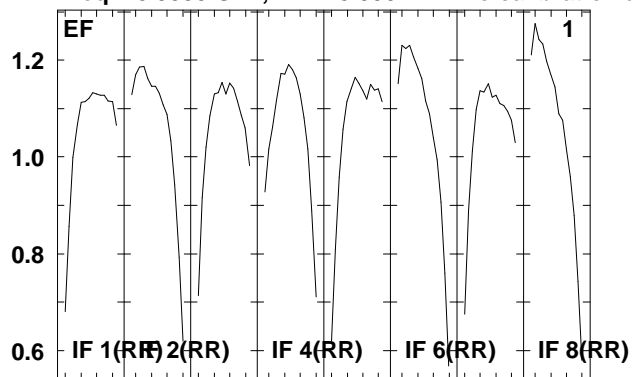

Lower frame: Real Jy  
Total-power spectrum Antenna: \*  
Timerange: 00/18:58:35 to 00/19:00:05



Plot file version 33 created 05-OCT-2009 09:28:21

NGC6240 EH023B 2.UVDATA.1

Freq = 8.3535 GHz, Bw = 8.000 MH No calibration applied and no bandpass applied

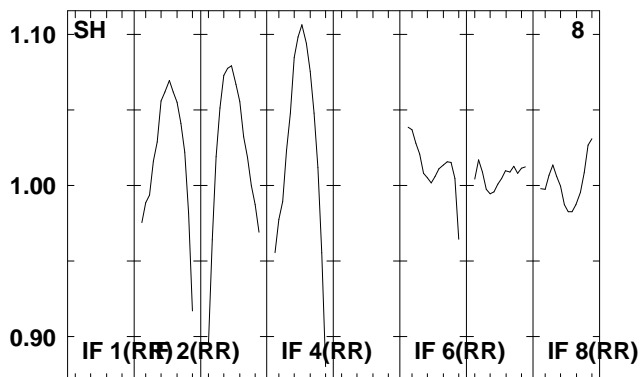
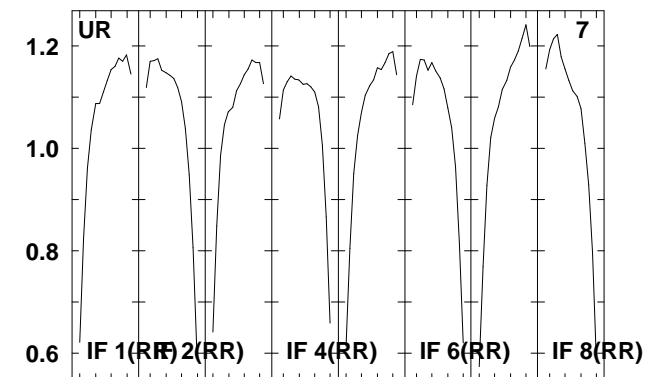
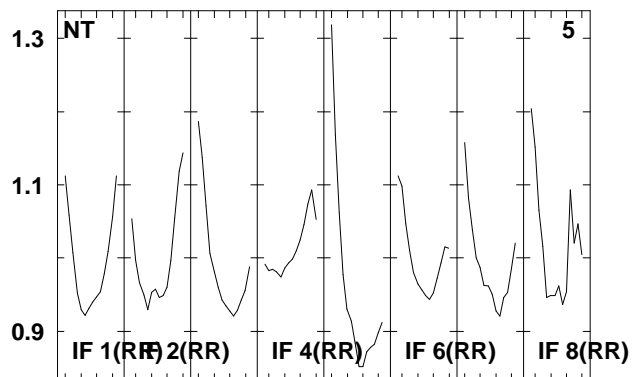
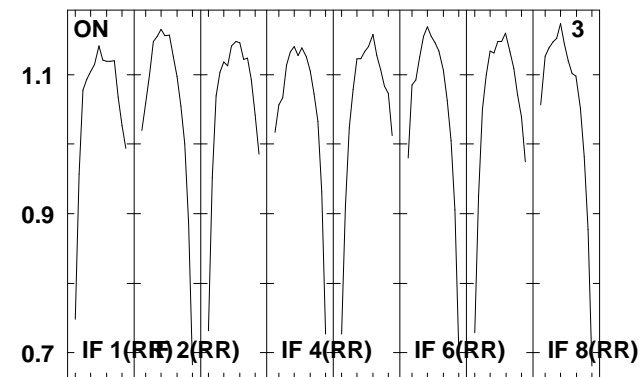
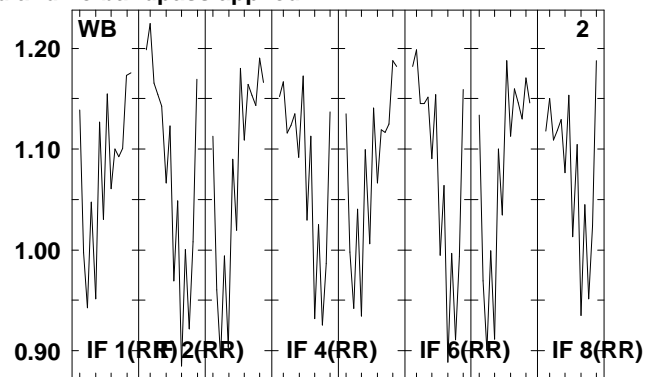
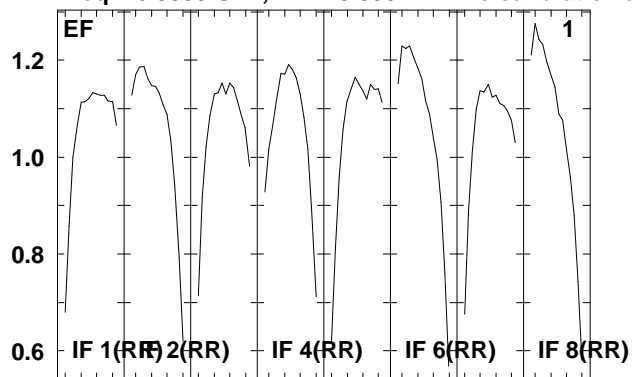

Lower frame: Real Jy  
Total-power spectrum Antenna: \*  
Timerange: 00/19:00:07 to 00/19:03:33

Plot file version 34 created 05-OCT-2009 09:28:21

J1651+01 EH023B 2.UVDATA.1

Freq = 8.3535 GHz, Bw = 8.000 MH No calibration applied and no bandpass applied

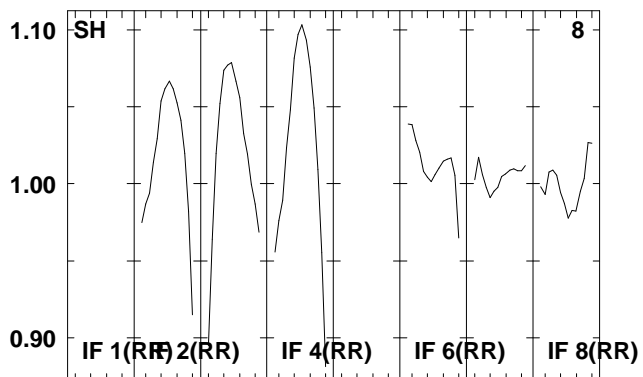
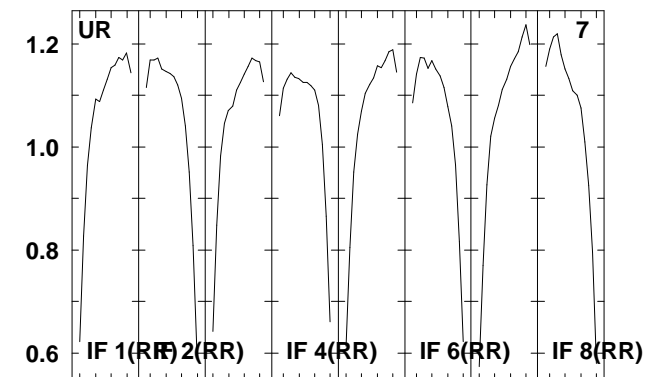
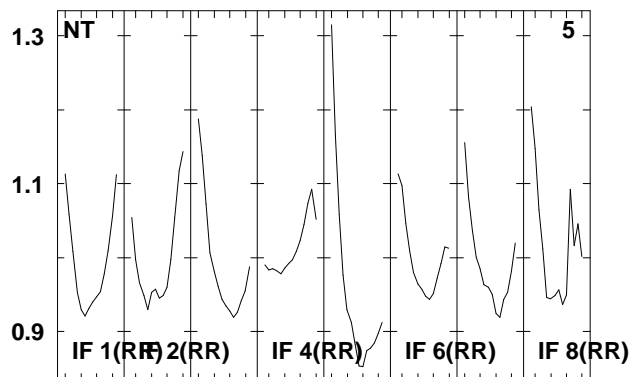
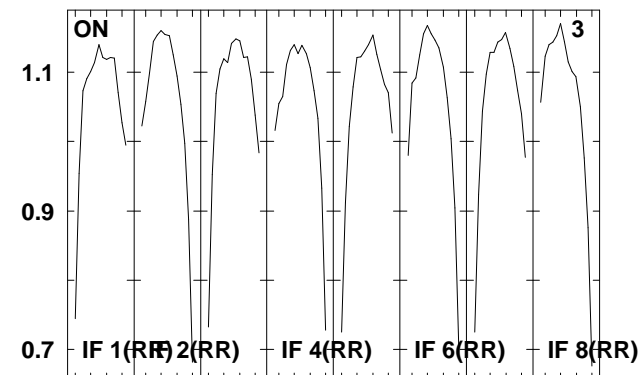
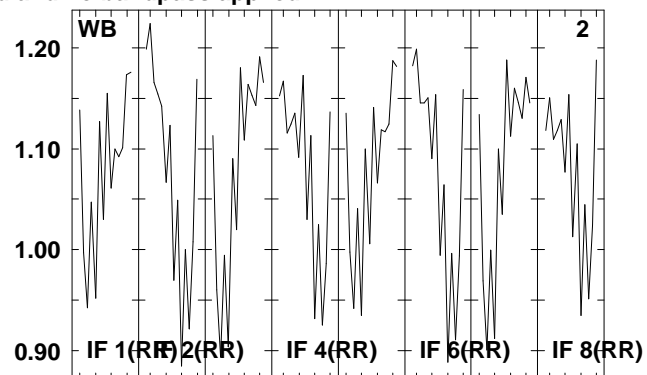
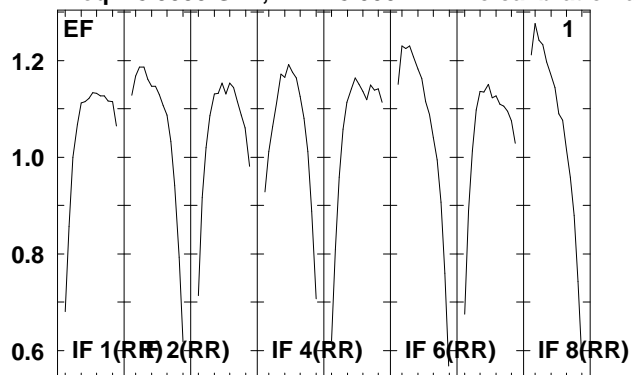

Lower frame: Real Jy  
Total-power spectrum Antenna: \*  
Timerange: 00/19:04:05 to 00/19:05:33

Plot file version 35 created 05-OCT-2009 09:28:21

NGC6240 EH023B 2.UVDATA.1

Freq = 8.3535 GHz, Bw = 8.000 MH No calibration applied and no bandpass applied

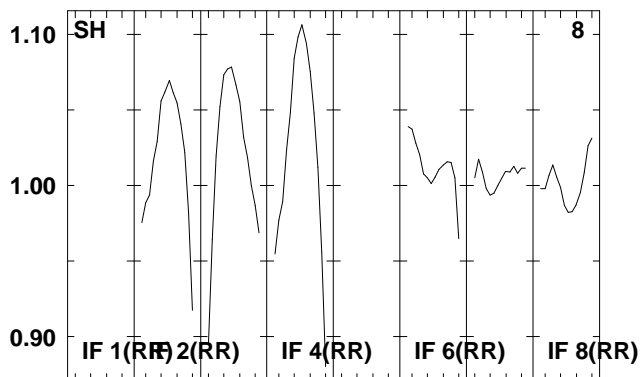
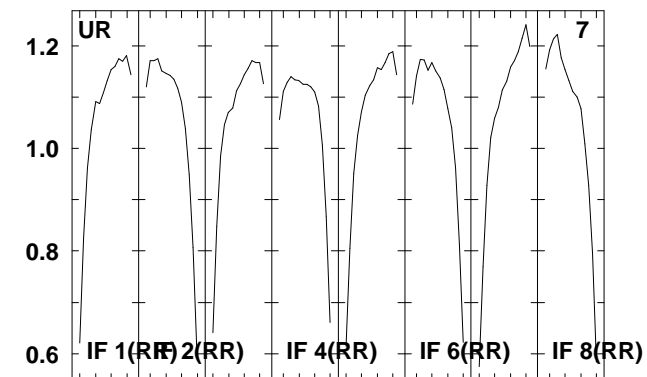
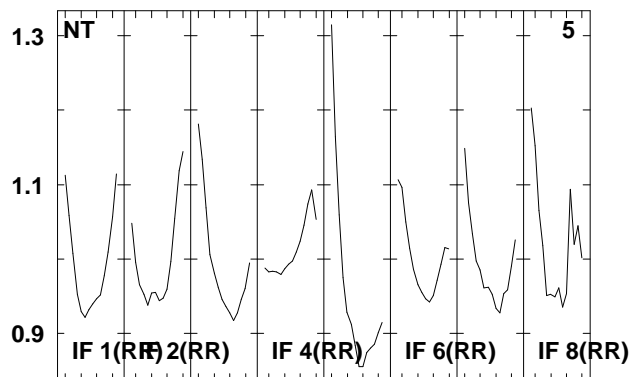
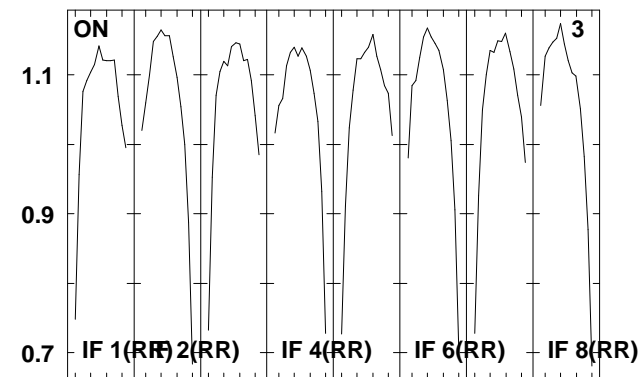
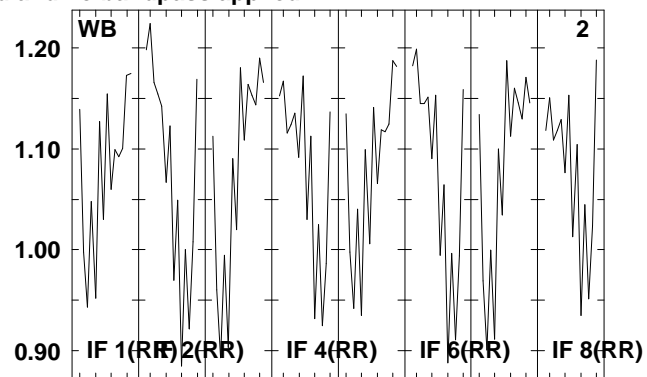
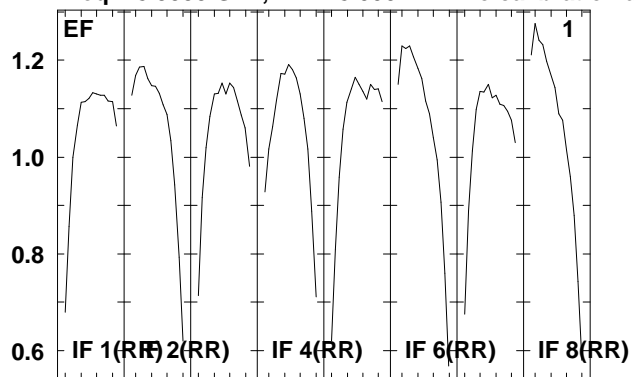

Lower frame: Real Jy  
Total-power spectrum Antenna: \*  
Timerange: 00/19:05:35 to 00/19:09:05

Plot file version 36 created 05-OCT-2009 09:28:21

J1651+01 EH023B 2.UVDATA.1

Freq = 8.3535 GHz, Bw = 8.000 MH No calibration applied and no bandpass applied

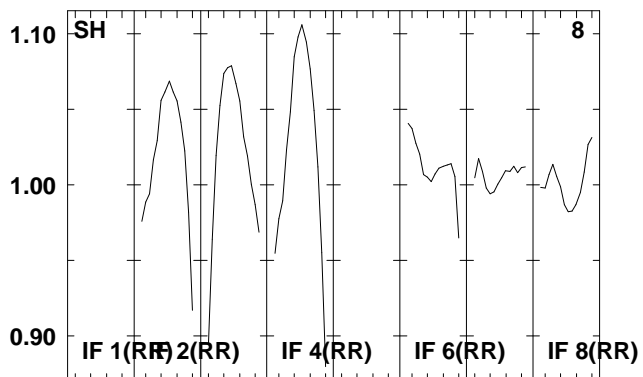
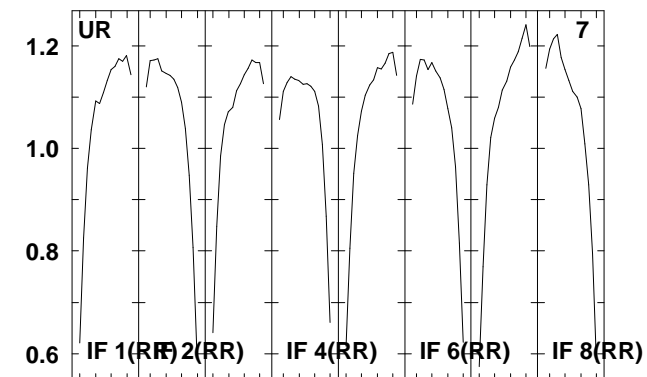
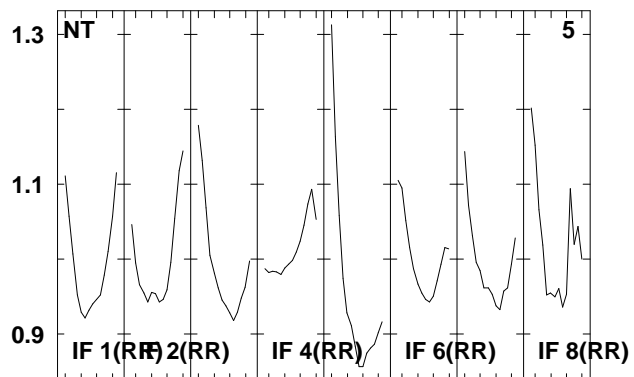
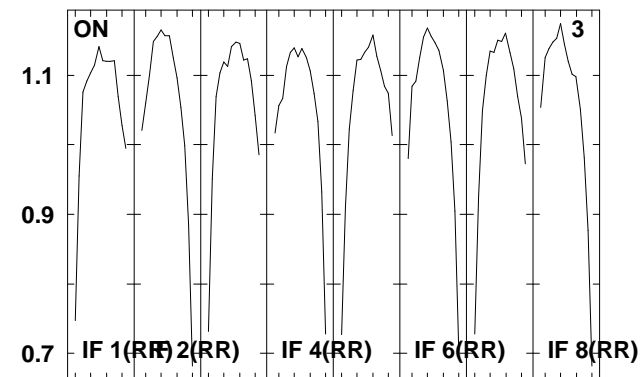
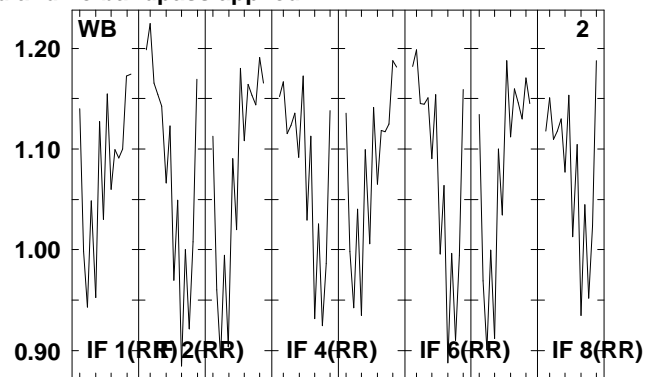
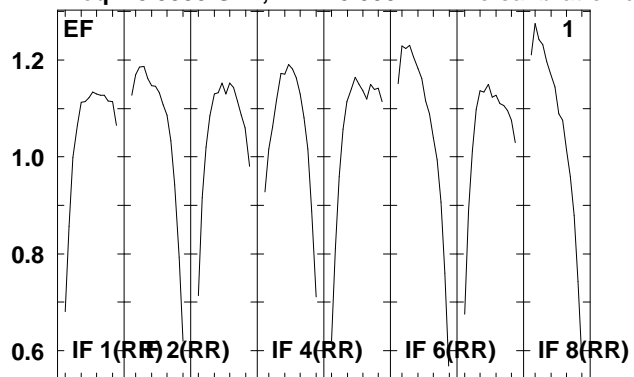

Lower frame: Real Jy  
Total-power spectrum Antenna: \*  
Timerange: 00/19:09:07 to 00/19:10:33

Plot file version 37 created 05-OCT-2009 09:28:21

NGC6240 EH023B 2.UVDATA.1

Freq = 8.3535 GHz, Bw = 8.000 MH No calibration applied and no bandpass applied

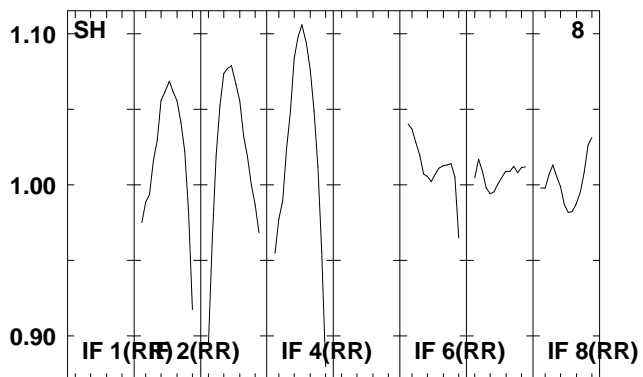
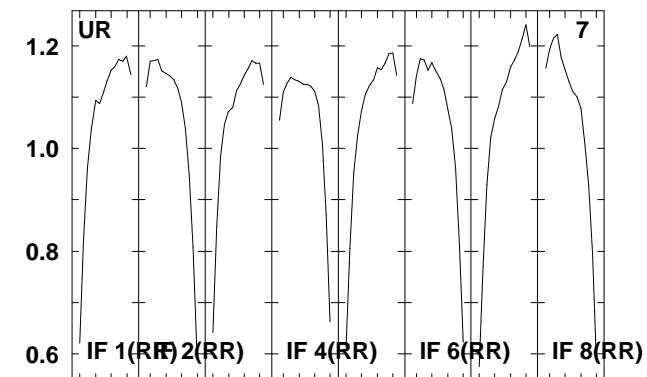
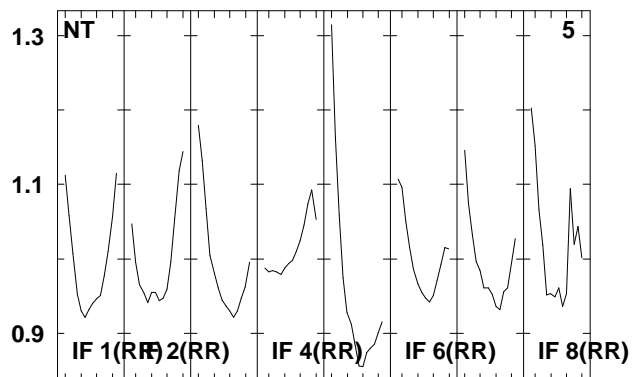
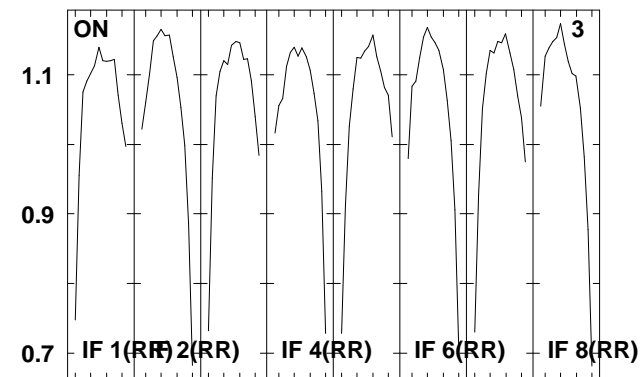
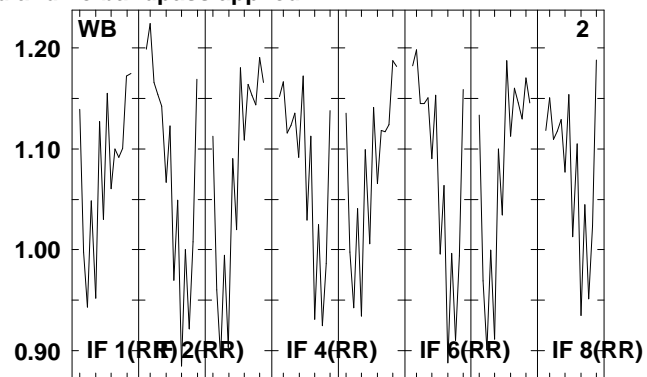
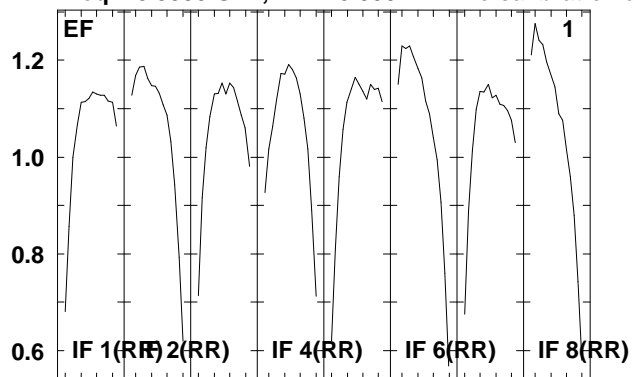

Lower frame: Real Jy  
Total-power spectrum Antenna: \*  
Timerange: 00/19:10:35 to 00/19:14:03

Plot file version 38 created 05-OCT-2009 09:28:21

J1651+01 EH023B 2.UVDATA.1

Freq = 8.3535 GHz, Bw = 8.000 MH No calibration applied and no bandpass applied

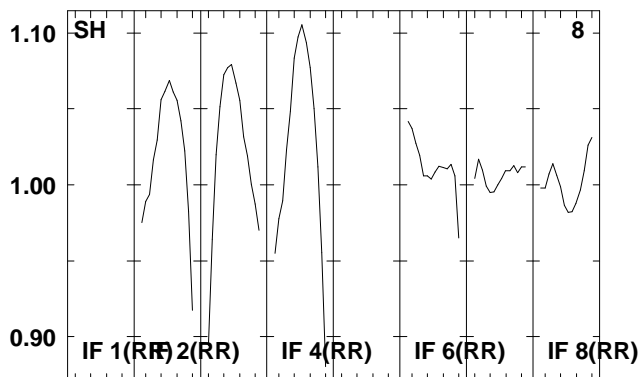
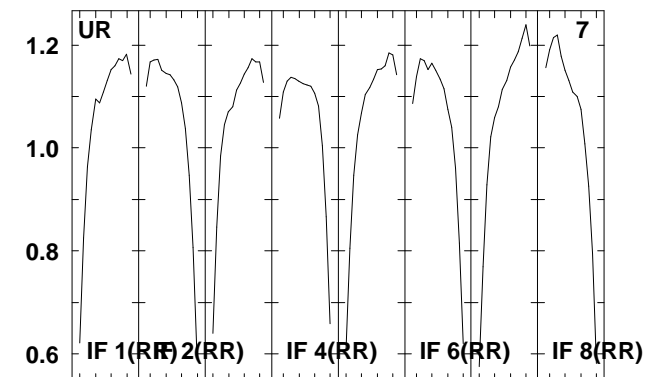
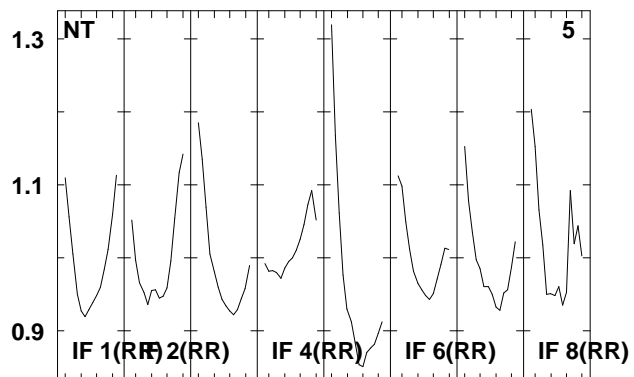
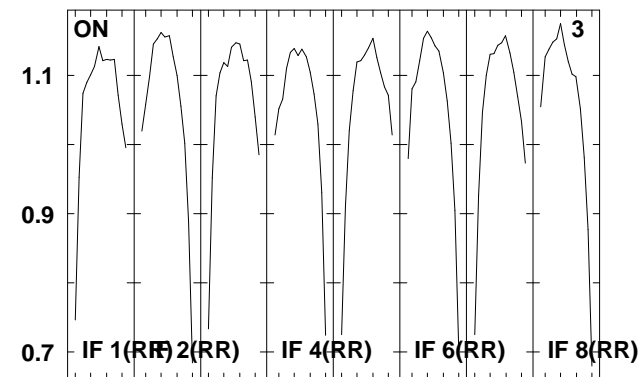
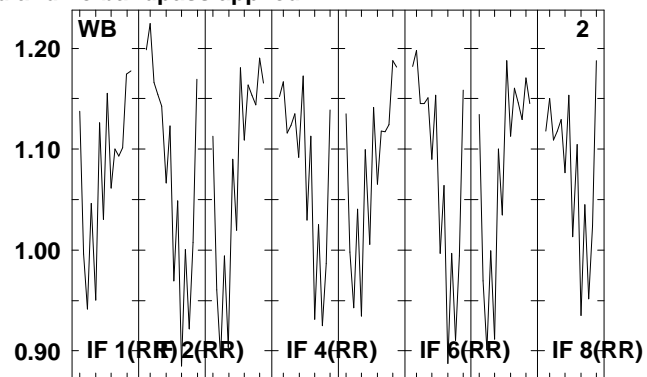
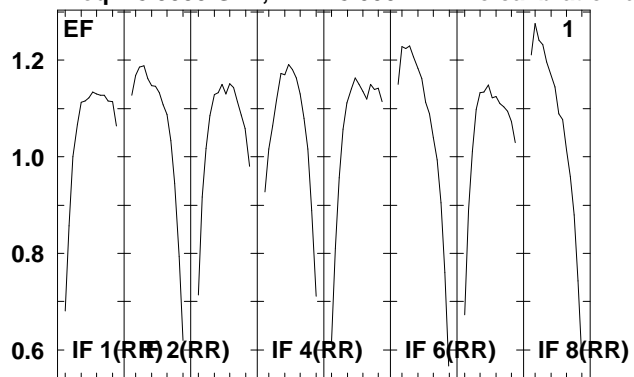

Lower frame: Real Jy  
Total-power spectrum Antenna: \*  
Timerange: 00/19:14:35 to 00/19:16:05

Plot file version 39 created 05-OCT-2009 09:28:21

NGC6240 EH023B 2.UVDATA.1

Freq = 8.3535 GHz, Bw = 8.000 MH No calibration applied and no bandpass applied

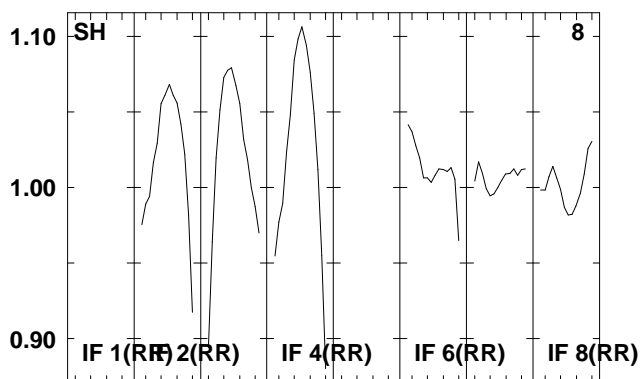
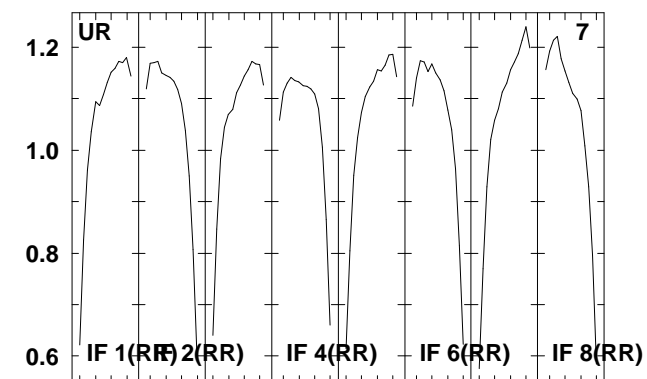
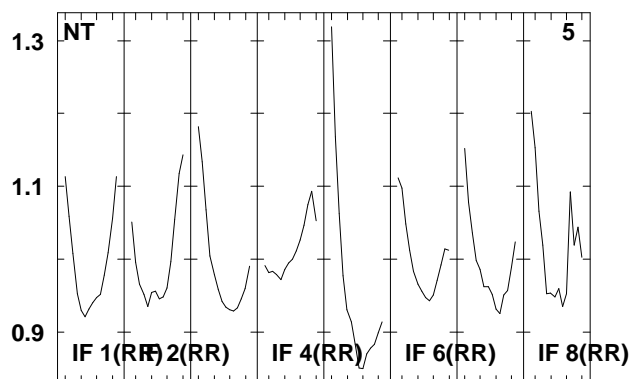
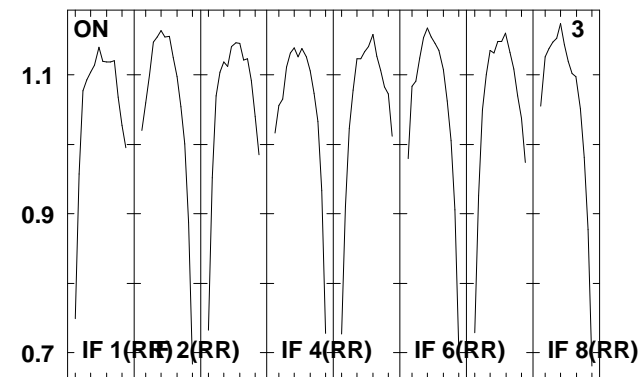
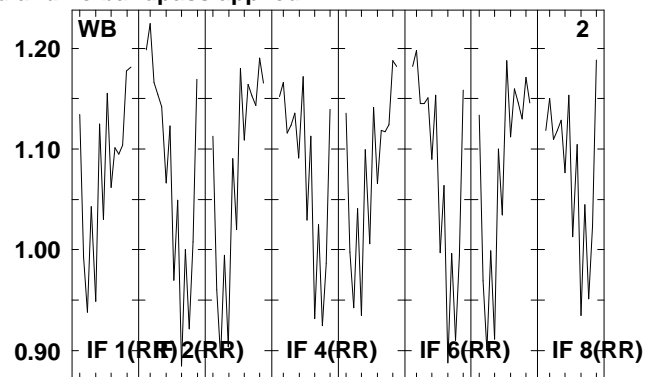
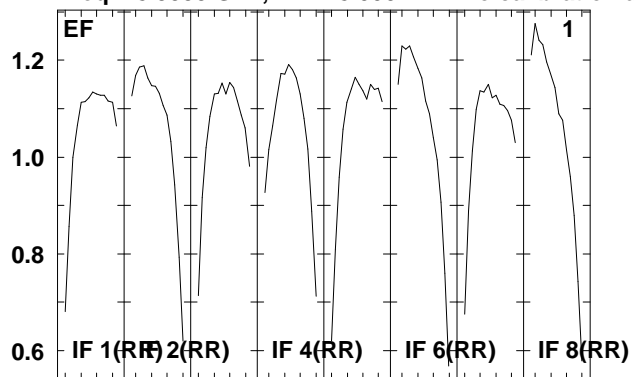

Lower frame: Real Jy  
Total-power spectrum Antenna: \*  
Timerange: 00/19:16:07 to 00/19:19:33

Plot file version 40 created 05-OCT-2009 09:28:22

J1651+01 EH023B 2.UVDATA.1

Freq = 8.3535 GHz, Bw = 8.000 MH No calibration applied and no bandpass applied

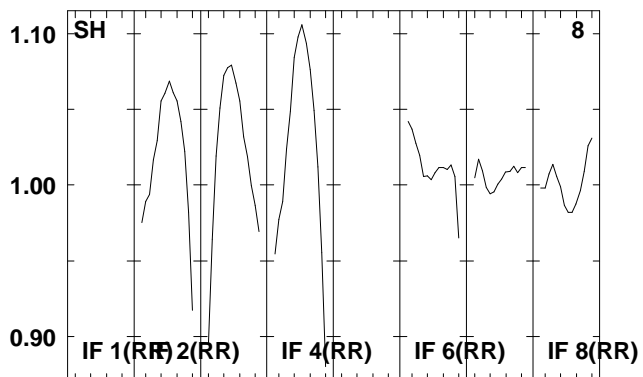
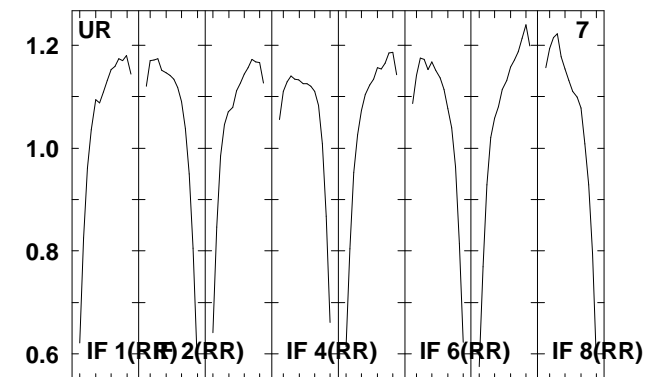
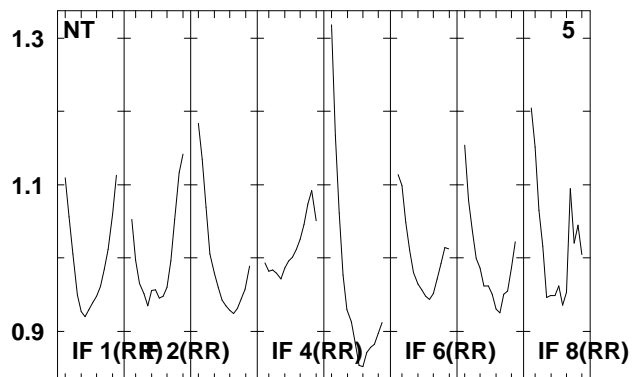
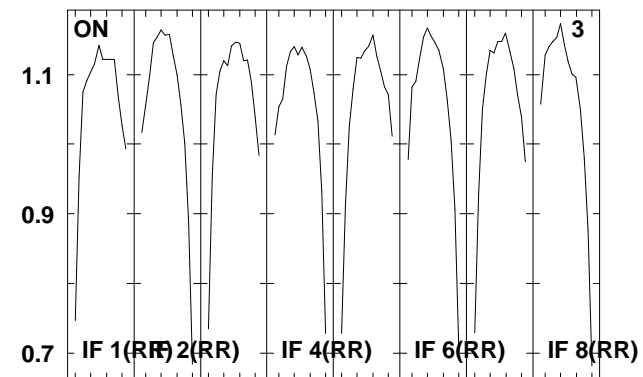
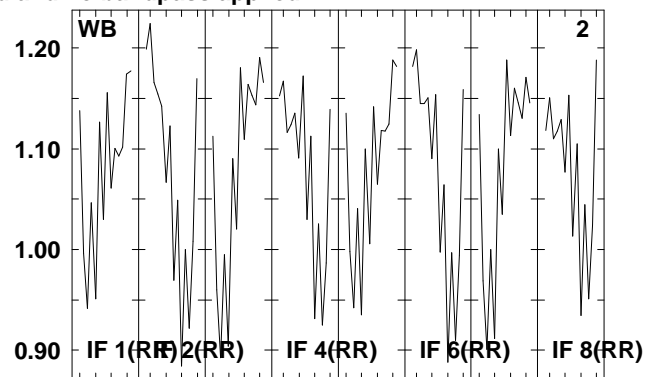
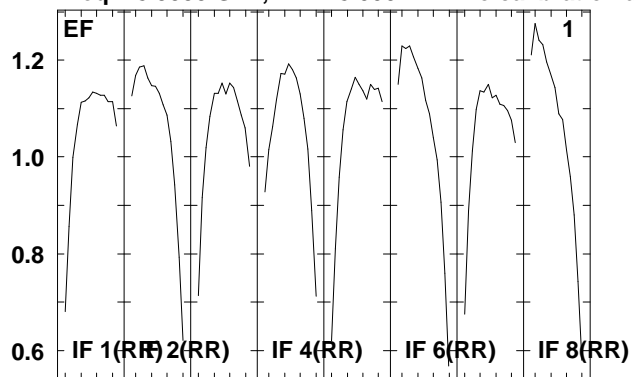

Lower frame: Real Jy  
Total-power spectrum Antenna: \*  
Timerange: 00/19:19:35 to 00/19:21:03



Plot file version 41 created 05-OCT-2009 09:28:22

NGC6240 EH023B 2.UVDATA.1

Freq = 8.3535 GHz, Bw = 8.000 MH No calibration applied and no bandpass applied

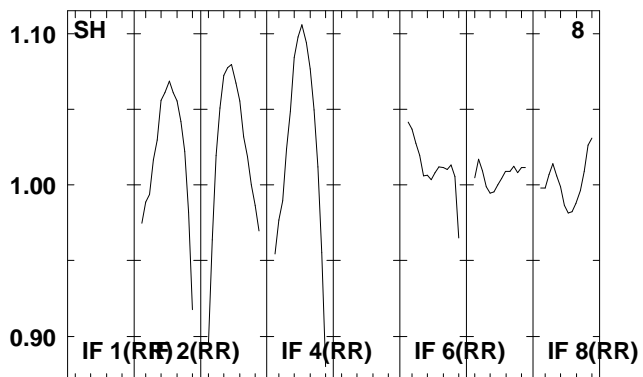
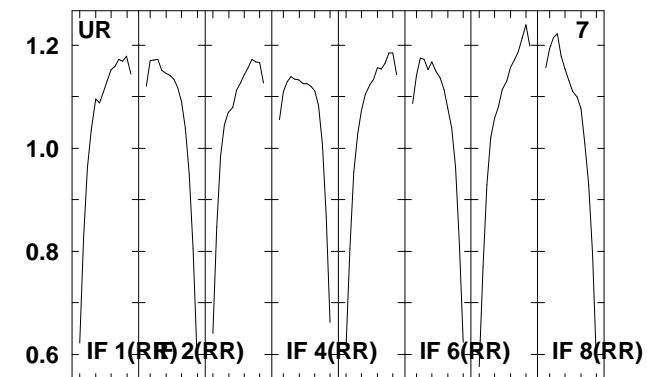
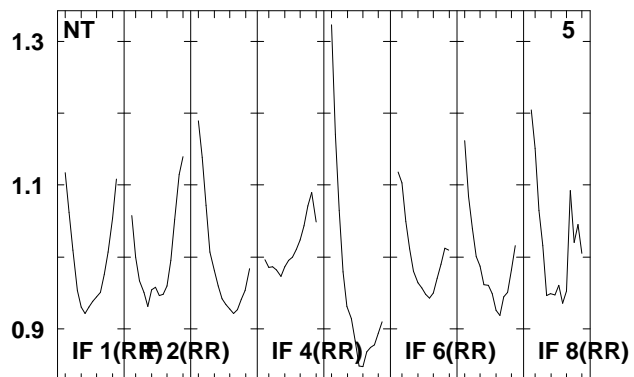
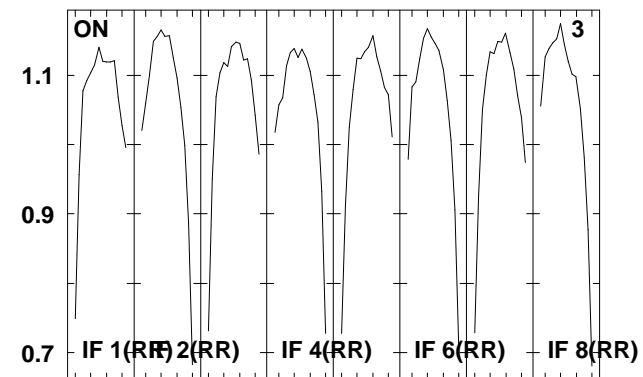
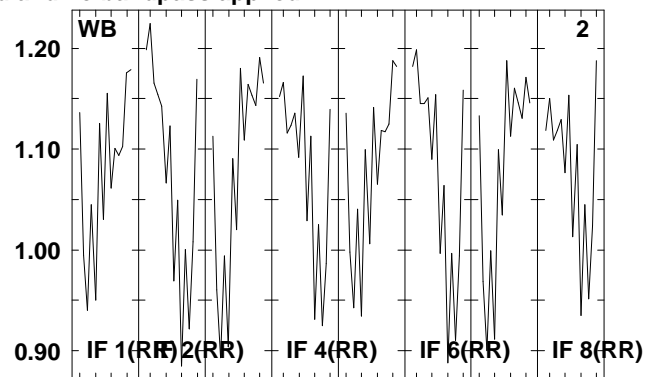
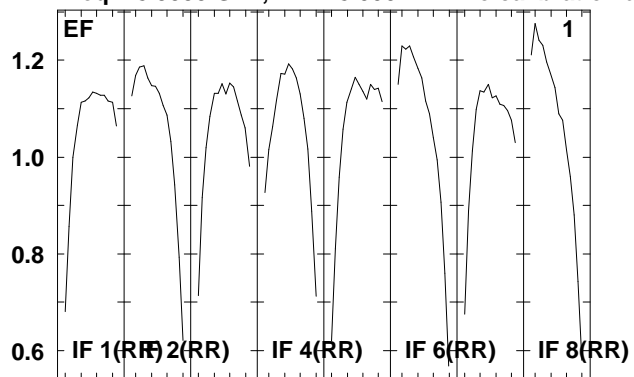

Lower frame: Real Jy  
Total-power spectrum Antenna: \*  
Timerange: 00/19:21:05 to 00/19:24:33

Plot file version 42 created 05-OCT-2009 09:28:22

J1651+01 EH023B 2.UVDATA.1

Freq = 8.3535 GHz, Bw = 8.000 MH No calibration applied and no bandpass applied

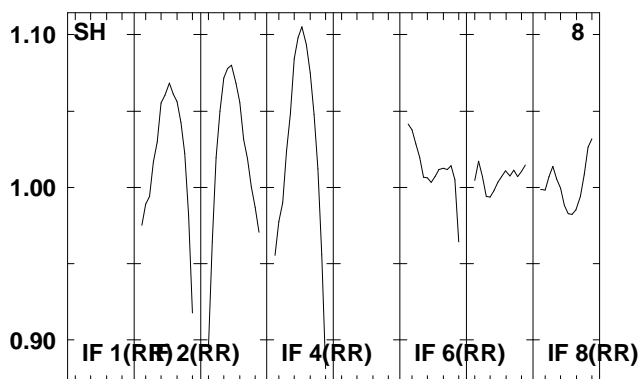
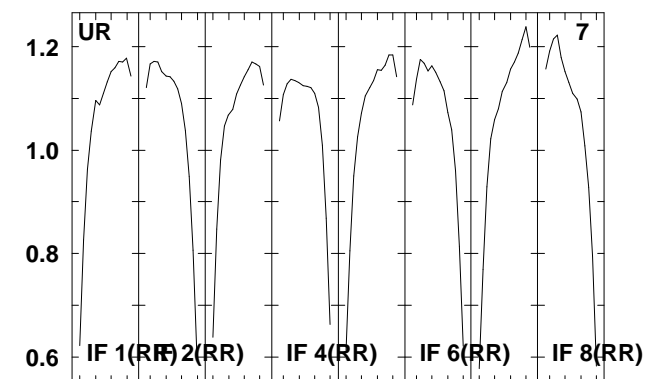
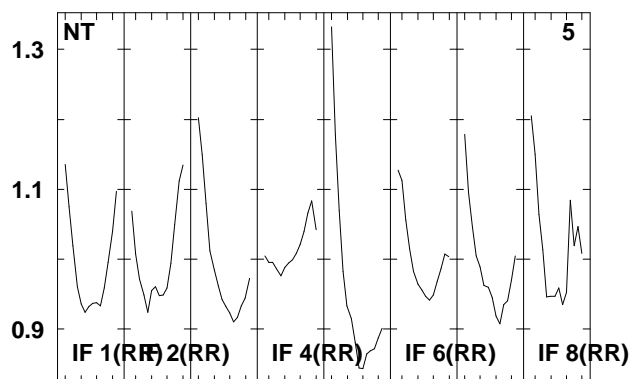
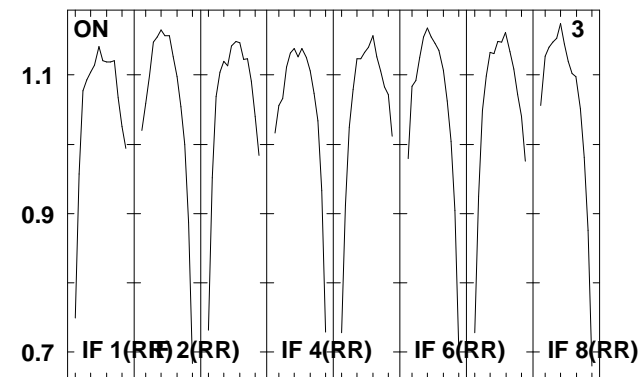
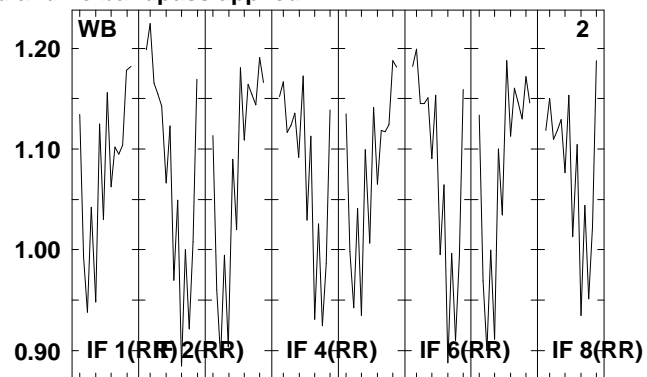
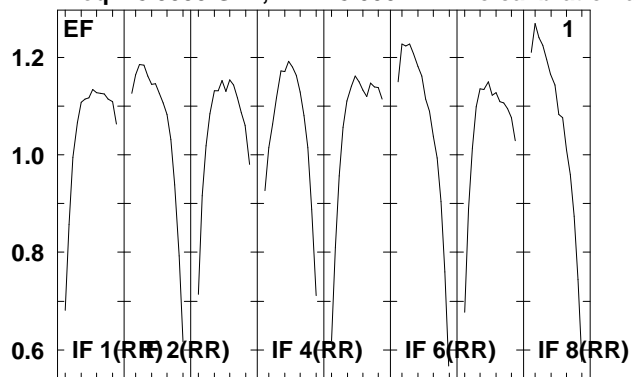

Lower frame: Real Jy  
Total-power spectrum Antenna: \*  
Timerange: 00/19:25:07 to 00/19:26:33

Plot file version 43 created 05-OCT-2009 09:28:22

NGC6240 EH023B 2.UVDATA.1

Freq = 8.3535 GHz, Bw = 8.000 MH No calibration applied and no bandpass applied

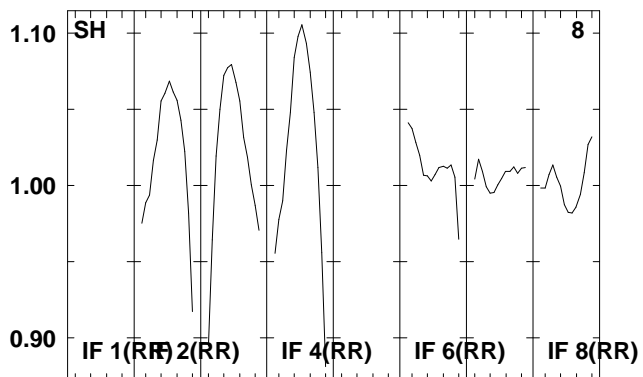
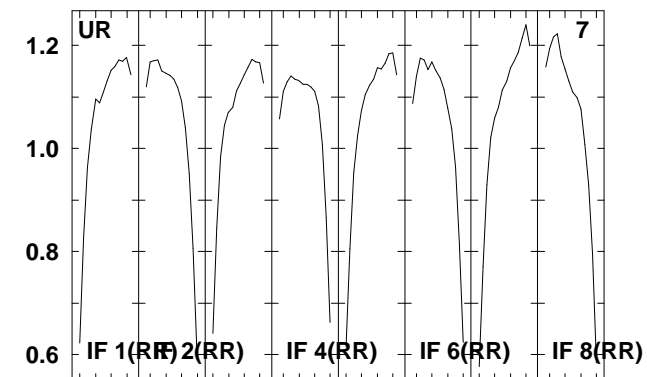
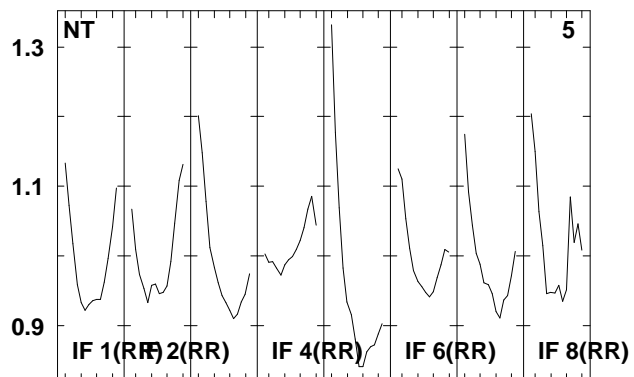
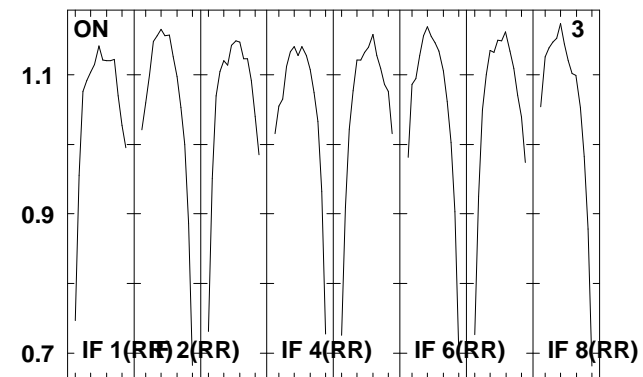
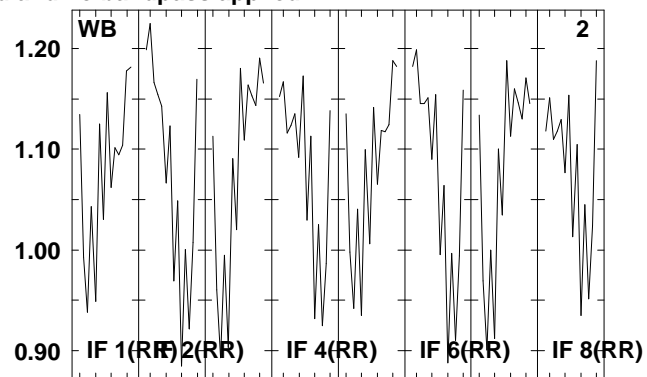
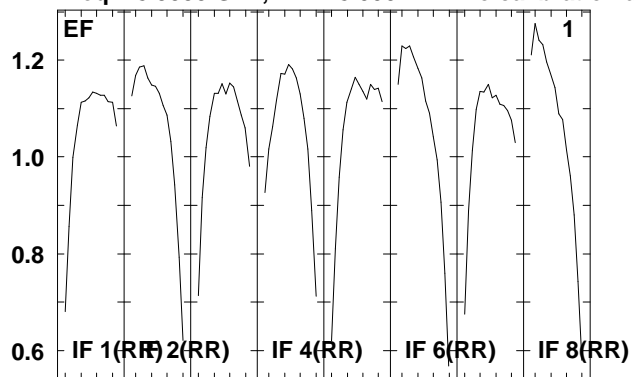

Lower frame: Real Jy  
Total-power spectrum Antenna: \*  
Timerange: 00/19:26:35 to 00/19:30:03

Plot file version 44 created 05-OCT-2009 09:28:22

J1651+01 EH023B 2.UVDATA.1

Freq = 8.3535 GHz, Bw = 8.000 MH No calibration applied and no bandpass applied

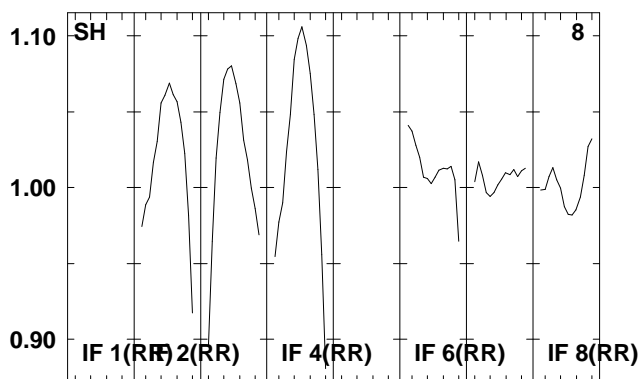
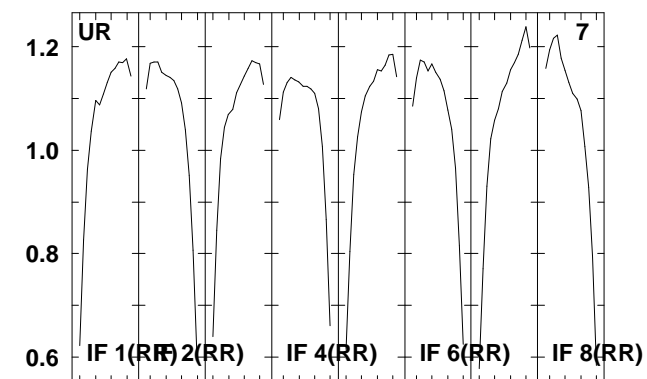
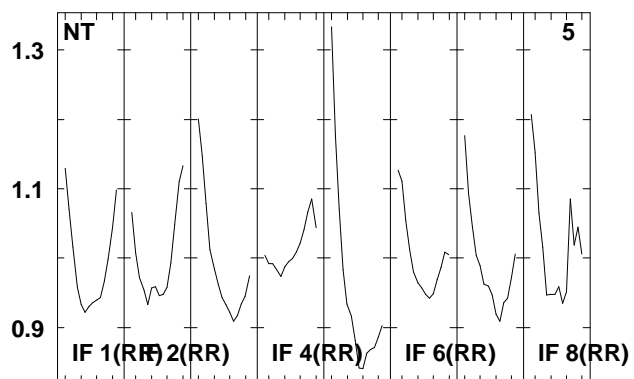
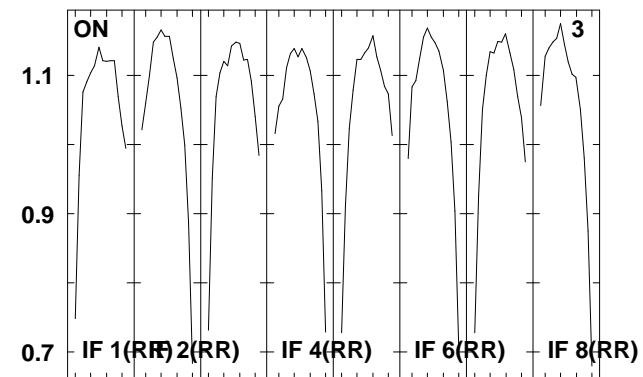
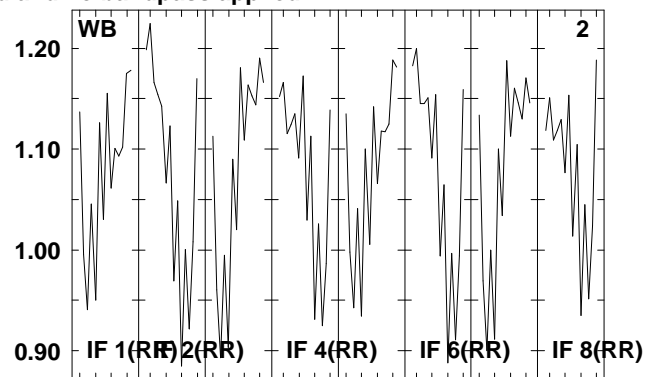
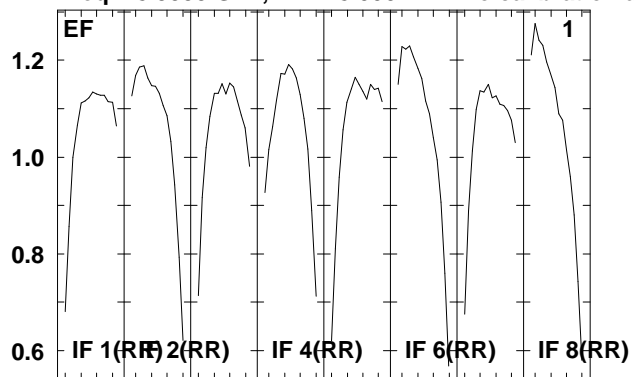

Lower frame: Real Jy  
Total-power spectrum Antenna: \*  
Timerange: 00/19:30:05 to 00/19:31:35

Plot file version 45 created 05-OCT-2009 09:28:22

NGC6240 EH023B 2.UVDATA.1

Freq = 8.3535 GHz, Bw = 8.000 MH No calibration applied and no bandpass applied

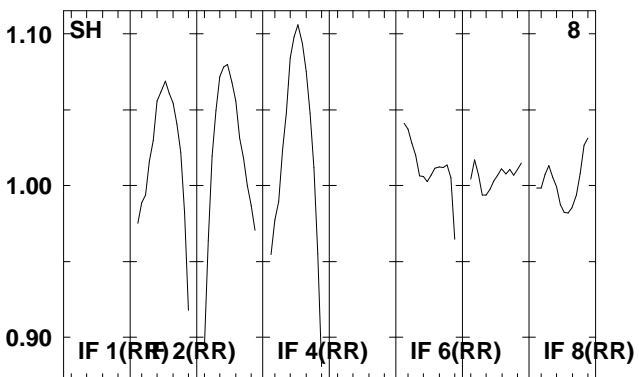
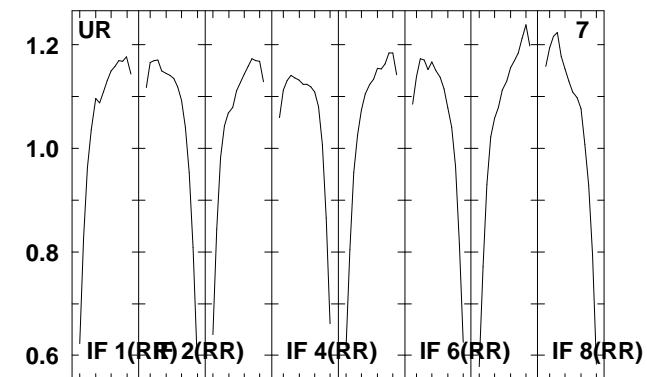
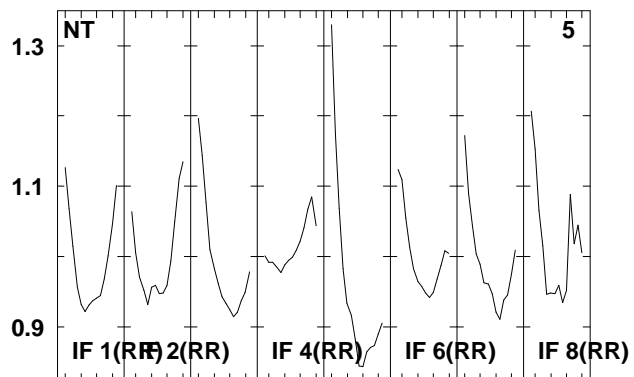
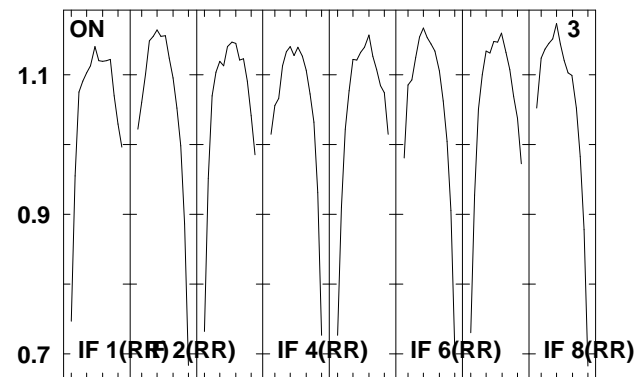
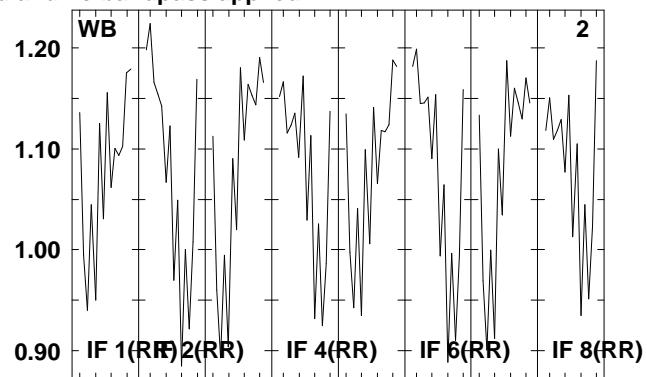
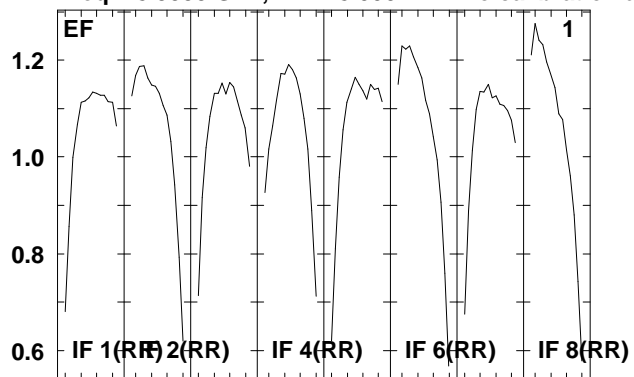

Lower frame: Real Jy  
Total-power spectrum Antenna: \*  
Timerange: 00/19:31:37 to 00/19:35:03

Plot file version 46 created 05-OCT-2009 09:28:23

J1651+01 EH023B 2.UVDATA.1

Freq = 8.3535 GHz, Bw = 8.000 MH No calibration applied and no bandpass applied

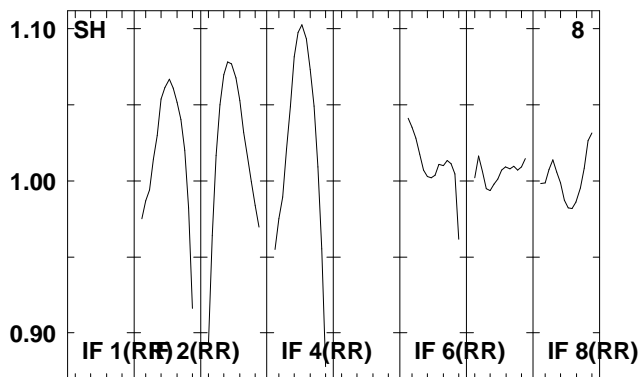
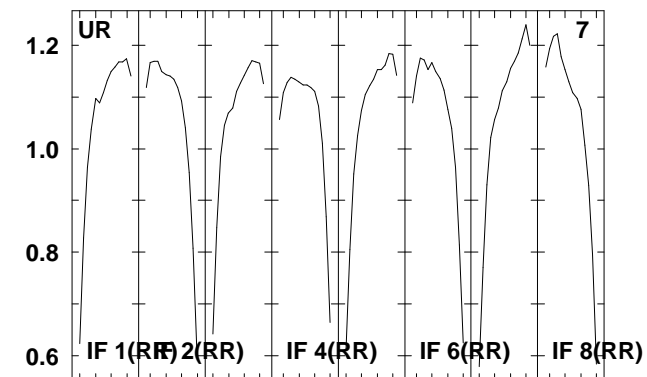
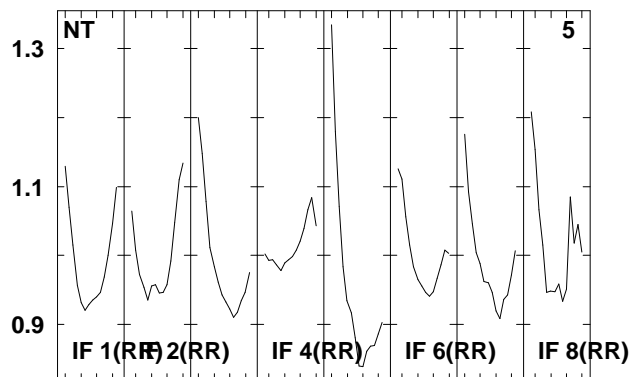
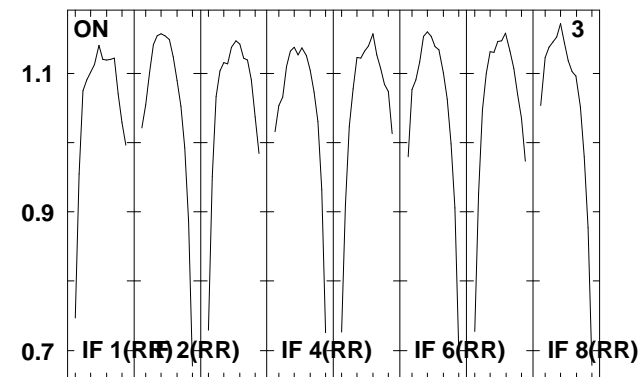
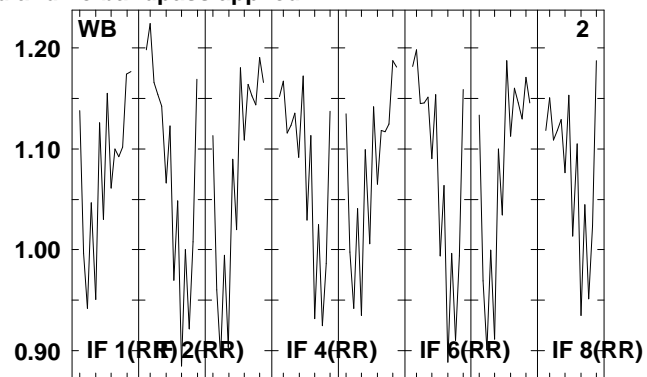
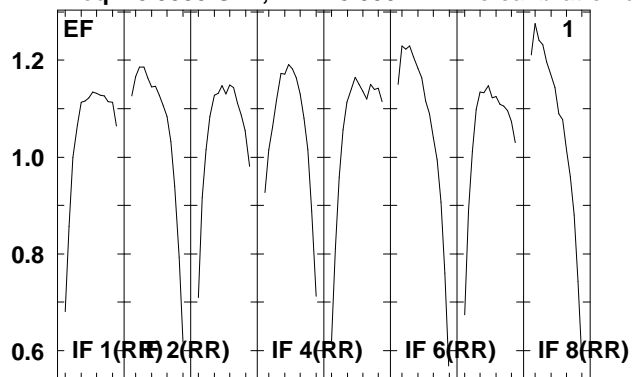

Lower frame: Real Jy  
Total-power spectrum Antenna: \*  
Timerange: 00/19:35:36 to 00/19:37:04

Plot file version 47 created 05-OCT-2009 09:28:23

NGC6240 EH023B 2.UVDATA.1

Freq = 8.3535 GHz, Bw = 8.000 MH No calibration applied and no bandpass applied

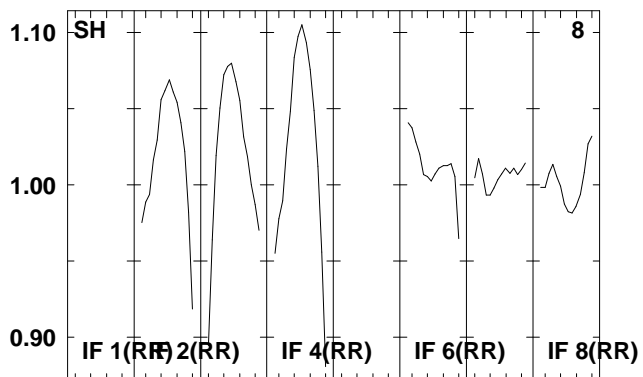
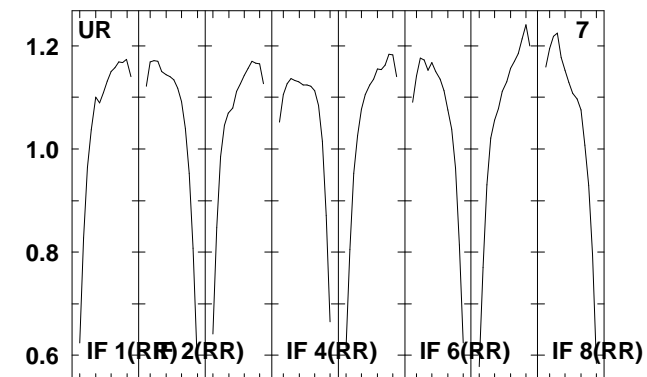
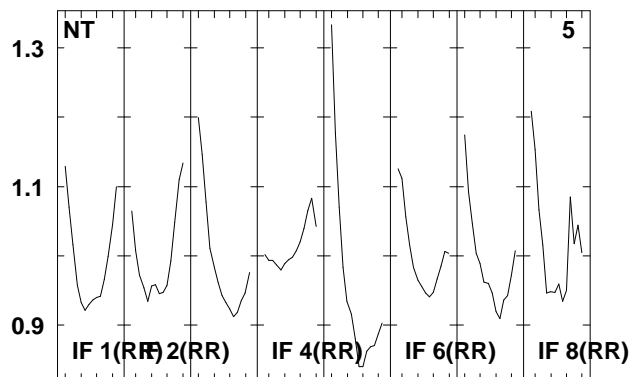
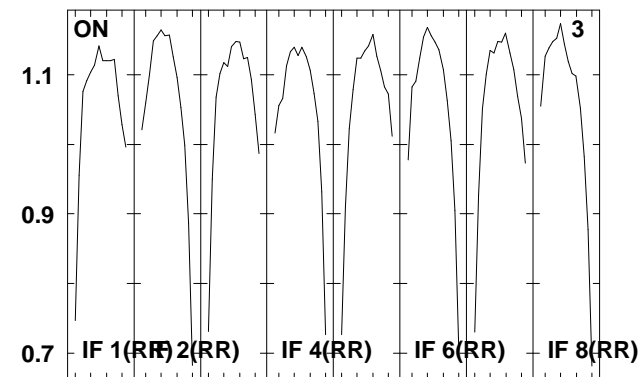
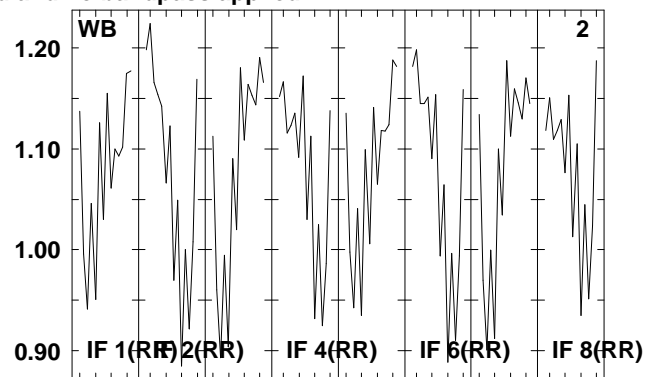
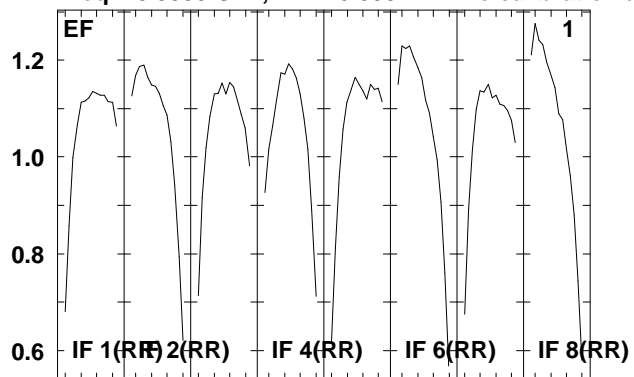

Lower frame: Real Jy  
Total-power spectrum Antenna: \*  
Timerange: 00/19:37:06 to 00/19:40:34

Plot file version 48 created 05-OCT-2009 09:28:23

J1651+01 EH023B 2.UVDATA.1

Freq = 8.3535 GHz, Bw = 8.000 MH No calibration applied and no bandpass applied

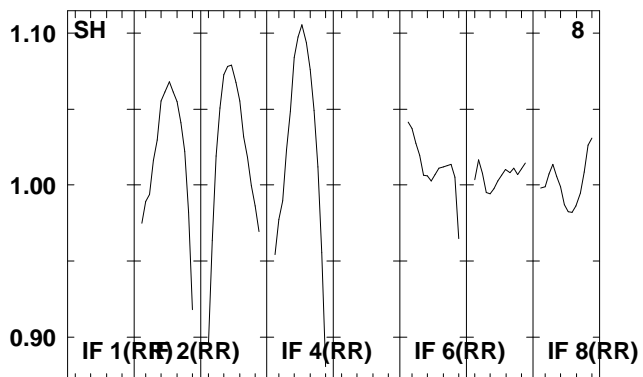
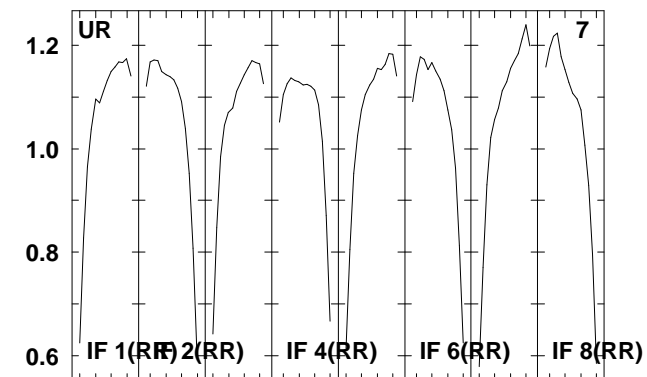
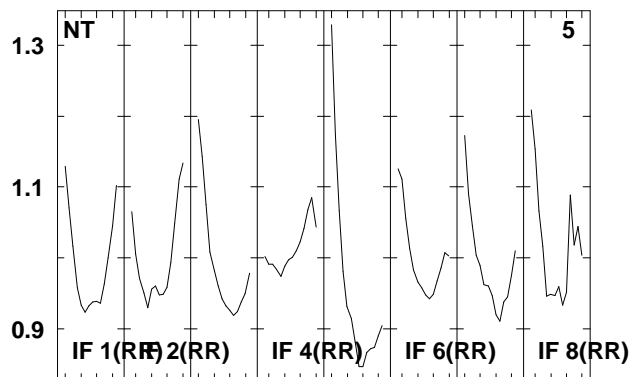
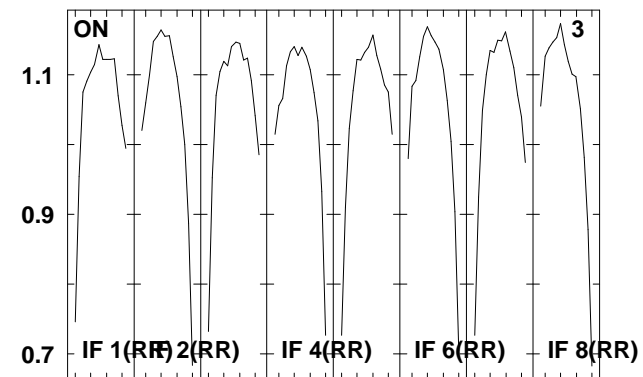
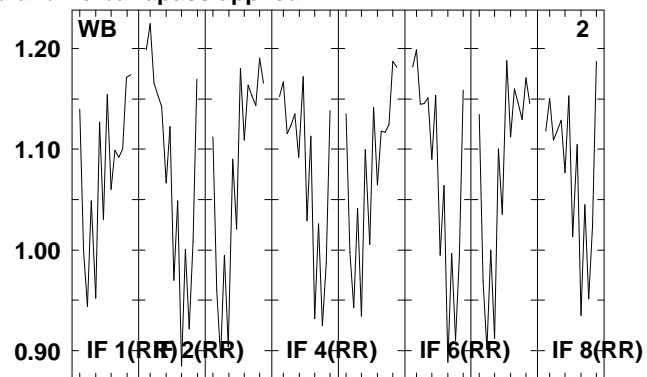
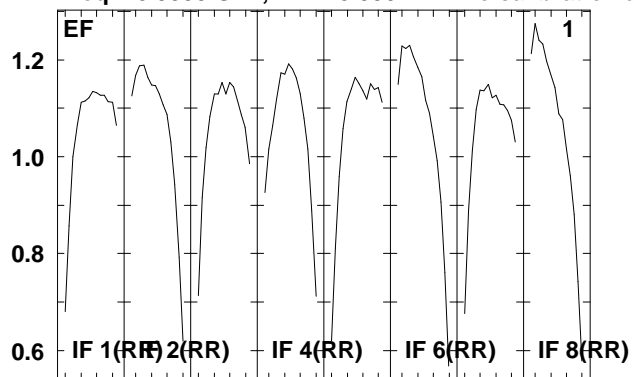

Lower frame: Real Jy  
Total-power spectrum Antenna: \*  
Timerange: 00/19:40:36 to 00/19:42:04



Plot file version 49 created 05-OCT-2009 09:28:23

NGC6240 EH023B 2.UVDATA.1

Freq = 8.3535 GHz, Bw = 8.000 MH No calibration applied and no bandpass applied

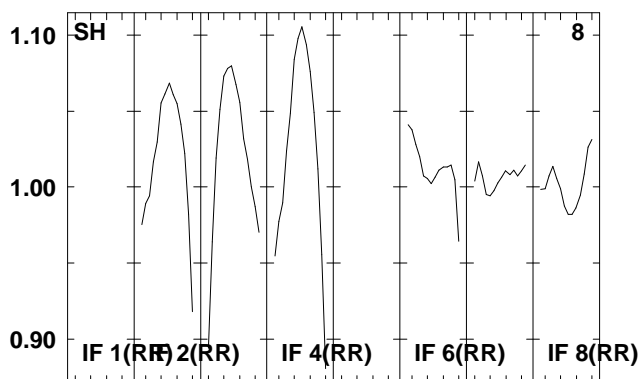
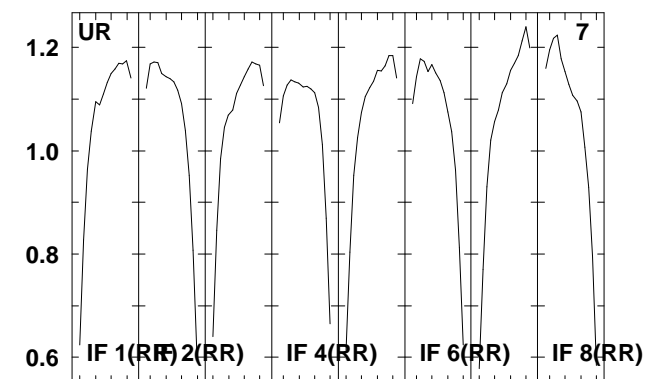
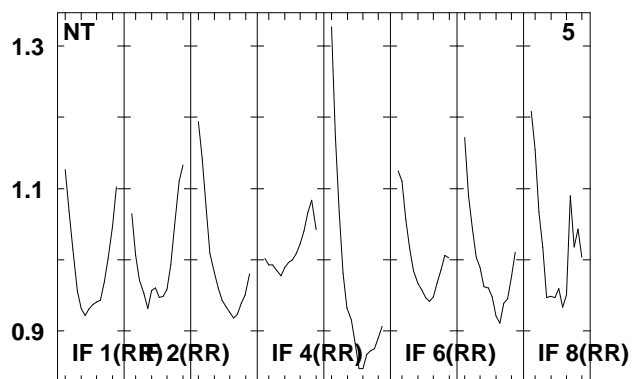
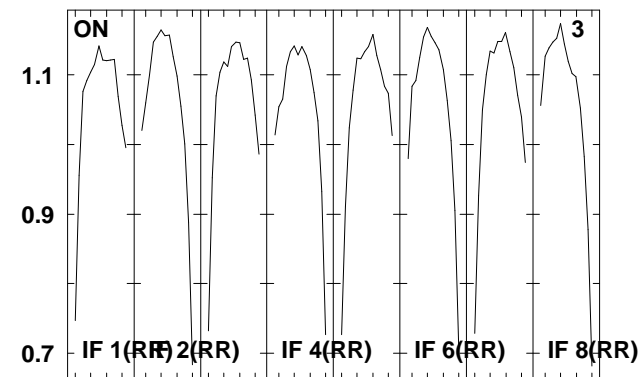
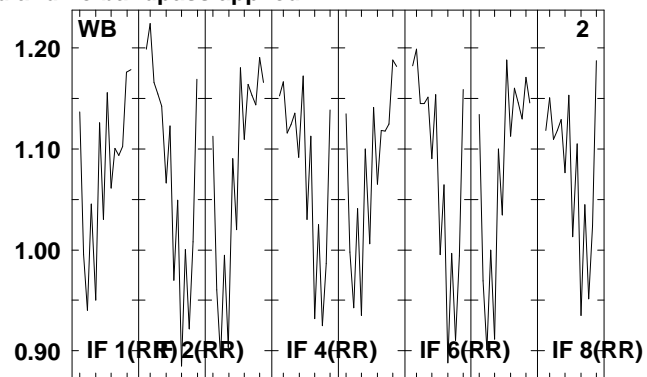
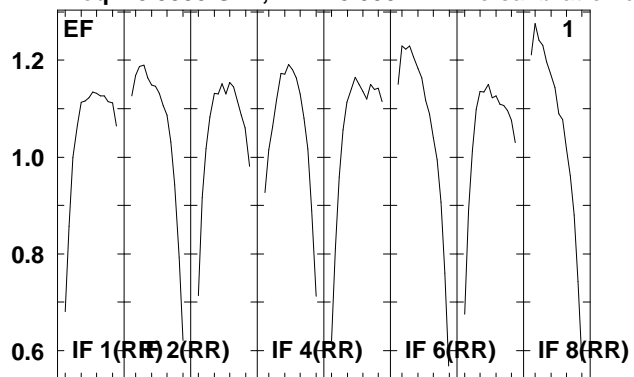

Lower frame: Real Jy  
Total-power spectrum Antenna: \*  
Timerange: 00/19:42:06 to 00/19:45:32

Plot file version 50 created 05-OCT-2009 09:28:23

J1651+01 EH023B 2.UVDATA.1

Freq = 8.3535 GHz, Bw = 8.000 MH No calibration applied and no bandpass applied

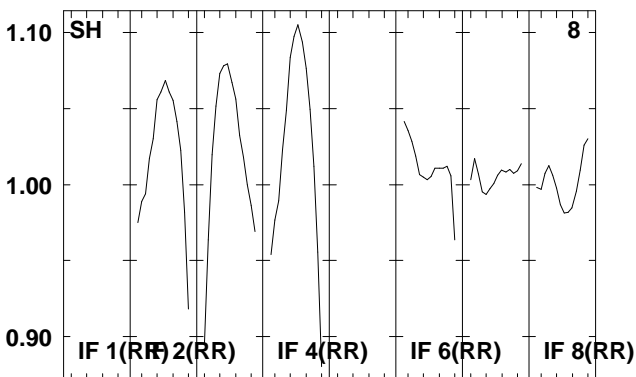
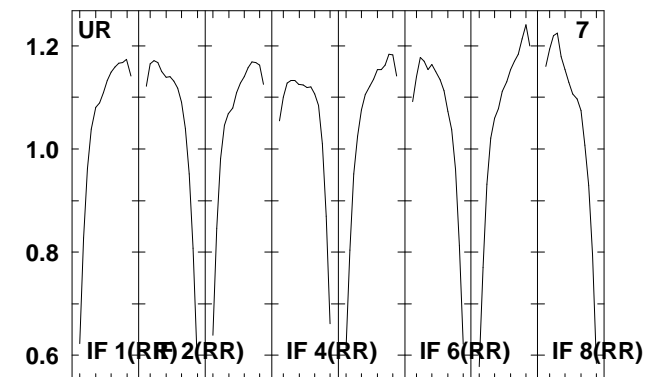
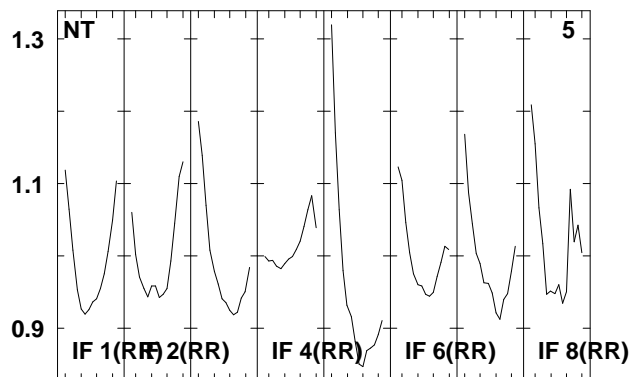
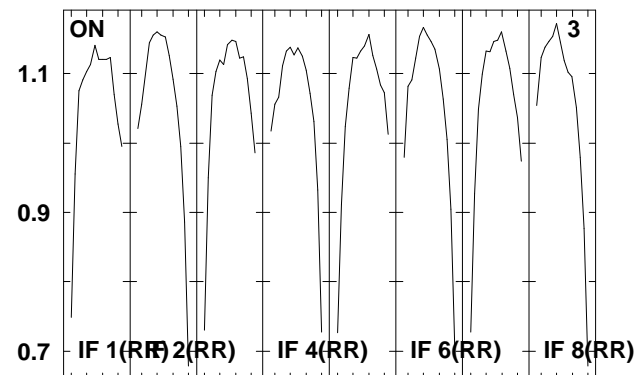
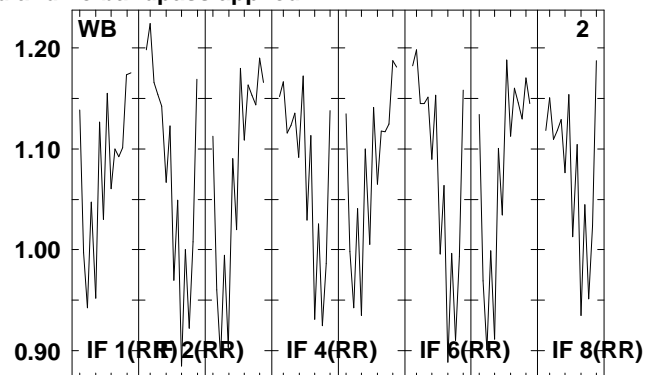
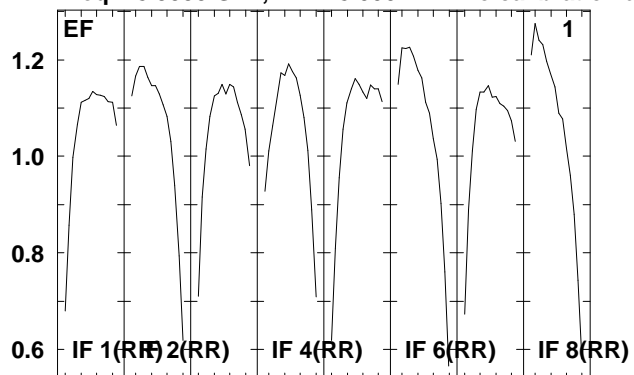

Lower frame: Real Jy  
Total-power spectrum Antenna: \*  
Timerange: 00/19:46:05 to 00/19:47:31

Plot file version 51 created 05-OCT-2009 09:28:23

NGC6240 EH023B 2.UVDATA.1

Freq = 8.3535 GHz, Bw = 8.000 MH No calibration applied and no bandpass applied

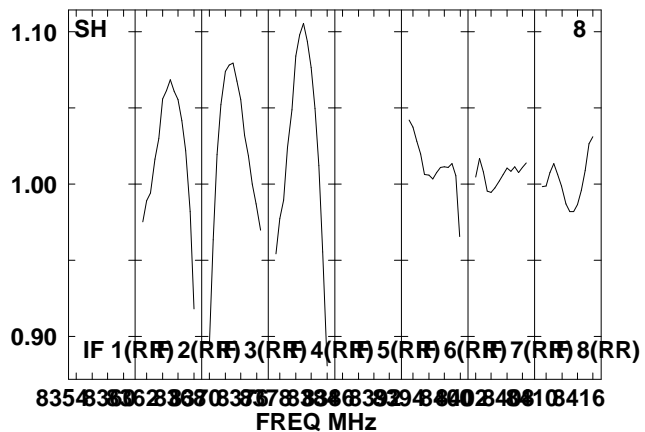
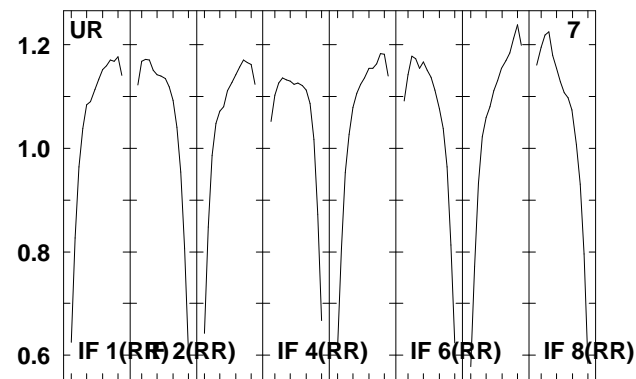
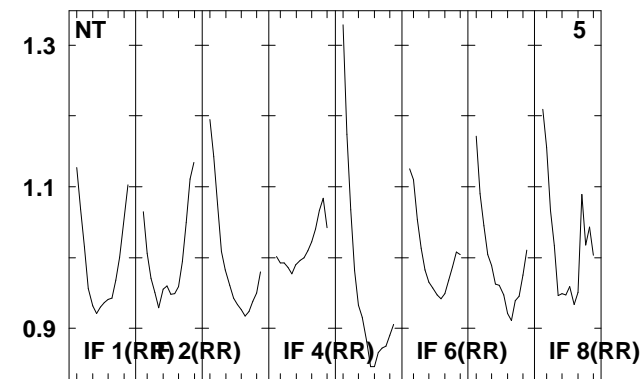
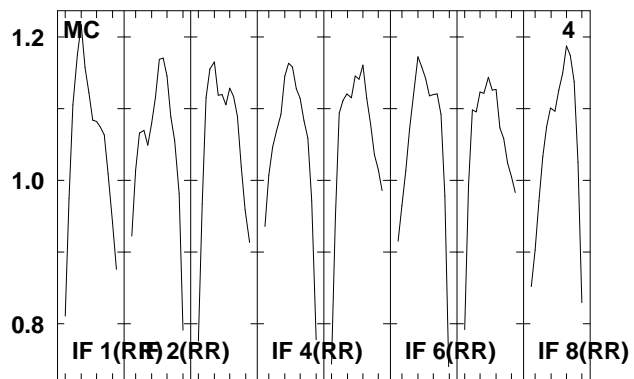
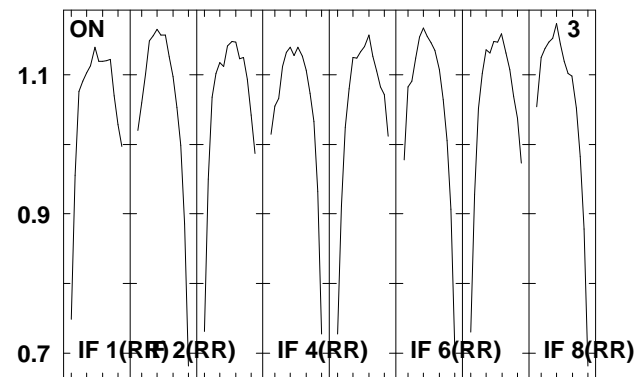
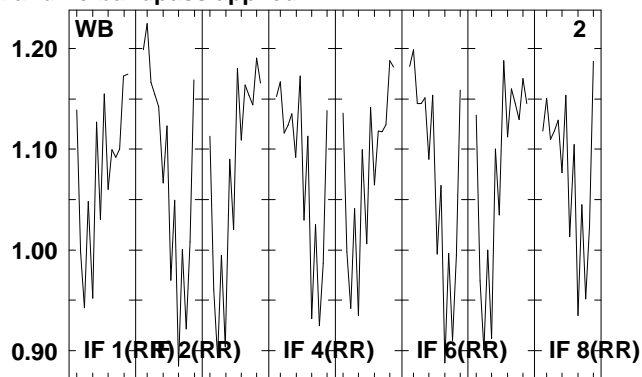
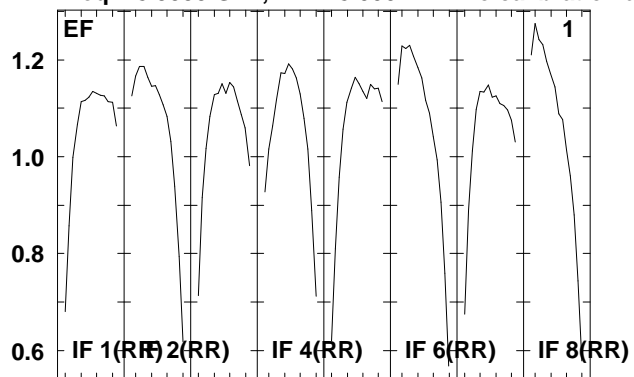

Lower frame: Real Jy

Total-power spectrum Antenna: \*

Timerange: 00/19:47:38 to 00/19:51:04

Plot file version 52 created 05-OCT-2009 09:28:24

J1651+01 EH023B 2.UVDATA.1

Freq = 8.3535 GHz, Bw = 8.000 MH No calibration applied and no bandpass applied

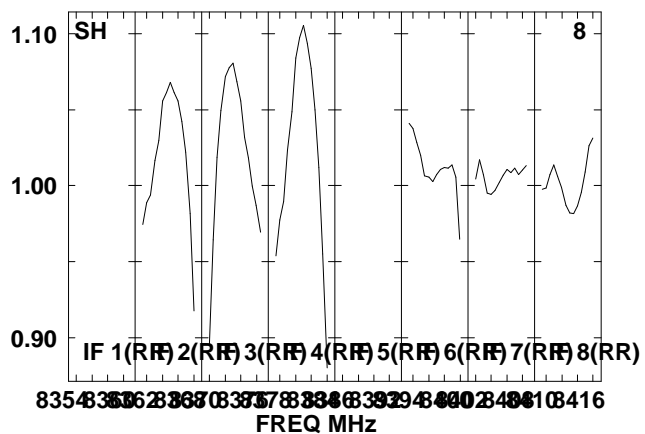
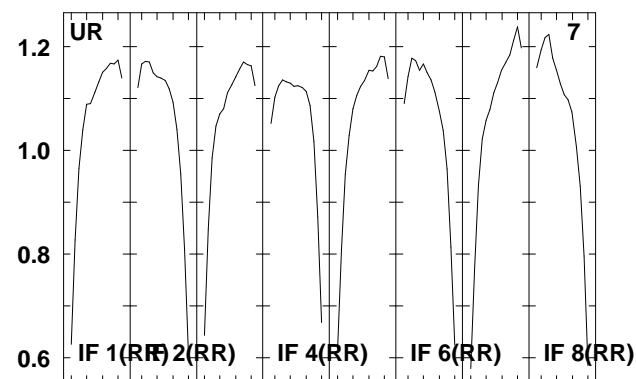
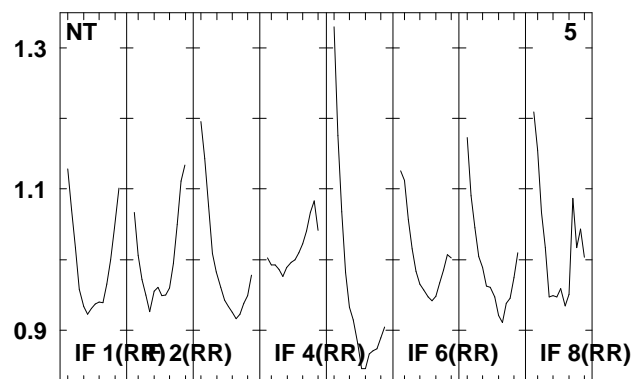
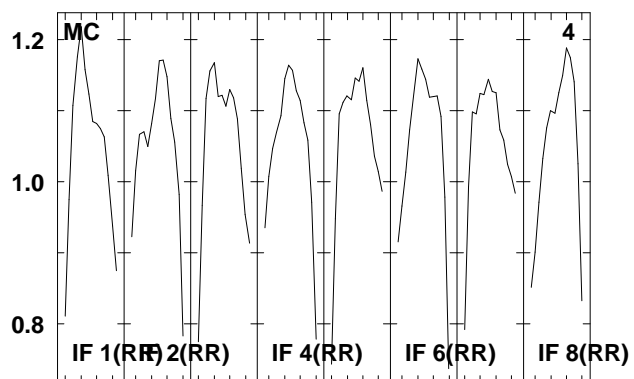
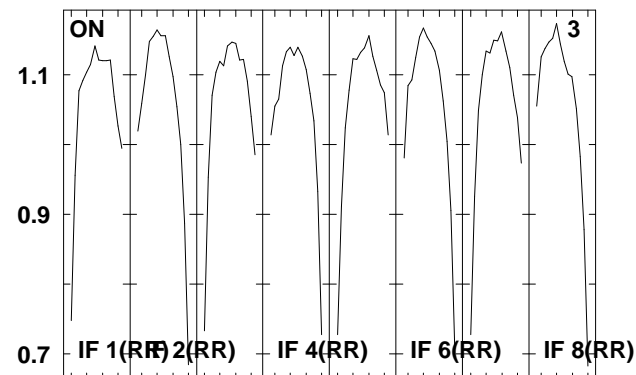
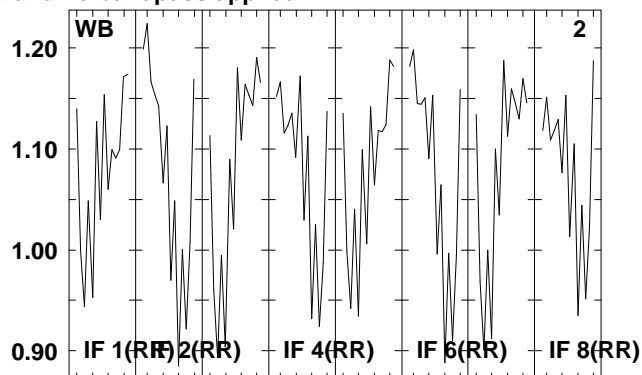
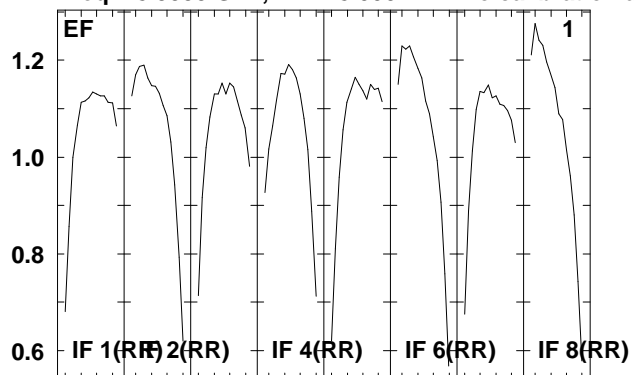

Lower frame: Real Jy

Total-power spectrum Antenna: \*

Timerange: 00/19:51:06 to 00/19:52:34

Plot file version 53 created 05-OCT-2009 09:28:24

NGC6240 EH023B 2.UVDATA.1

Freq = 8.3535 GHz, Bw = 8.000 MH No calibration applied and no bandpass applied

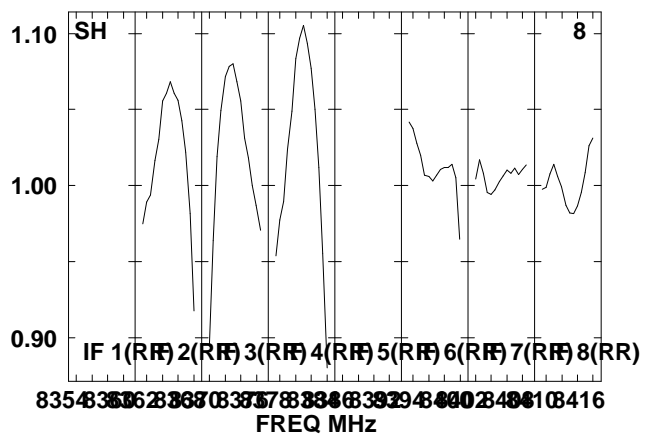
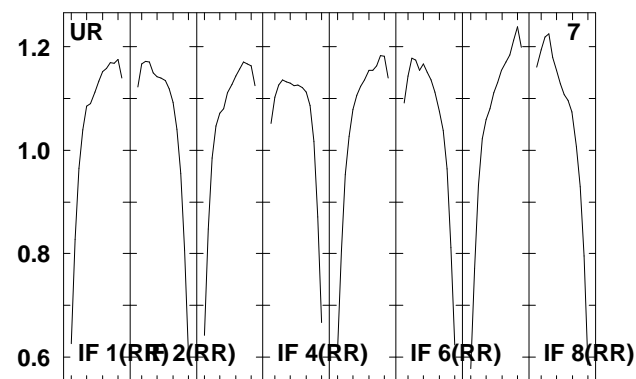
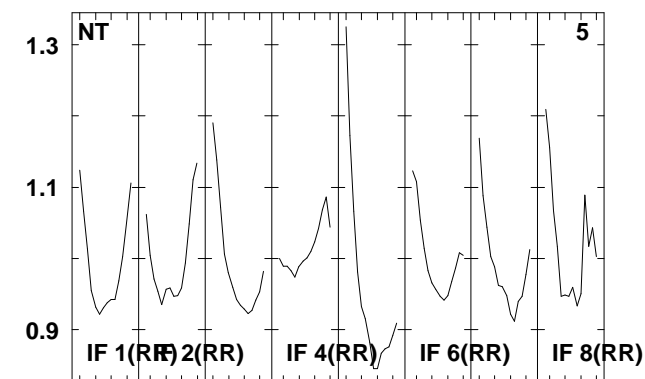
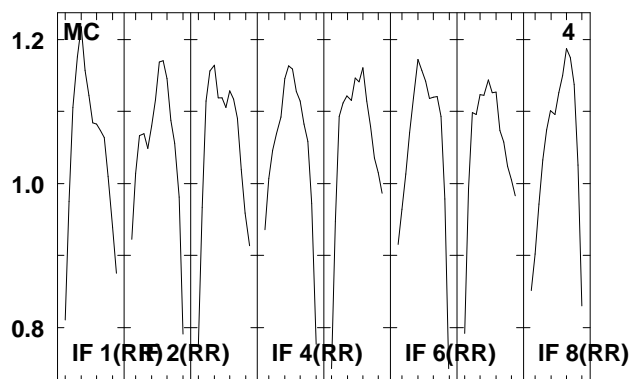
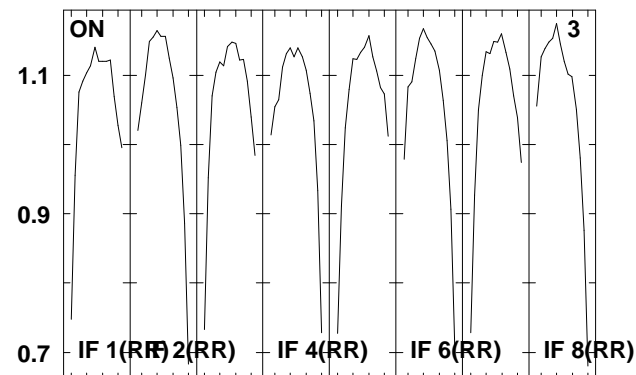
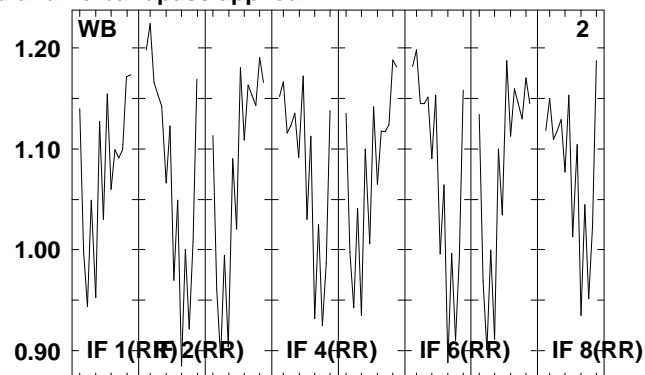
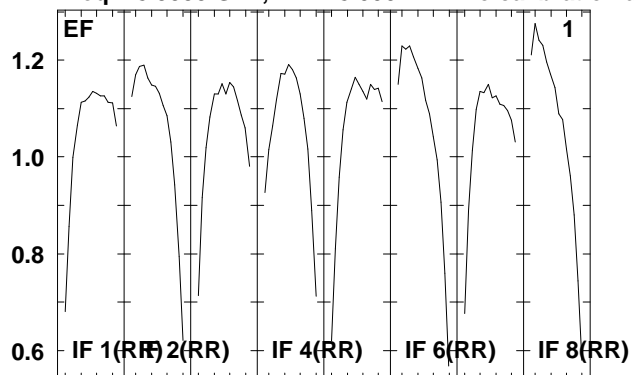

Lower frame: Real Jy

Total-power spectrum Antenna: \*

Timerange: 00/19:52:36 to 00/19:56:04

Plot file version 54 created 05-OCT-2009 09:28:24

J1651+01 EH023B 2.UVDATA.1

Freq = 8.3535 GHz, Bw = 8.000 MH No calibration applied and no bandpass applied

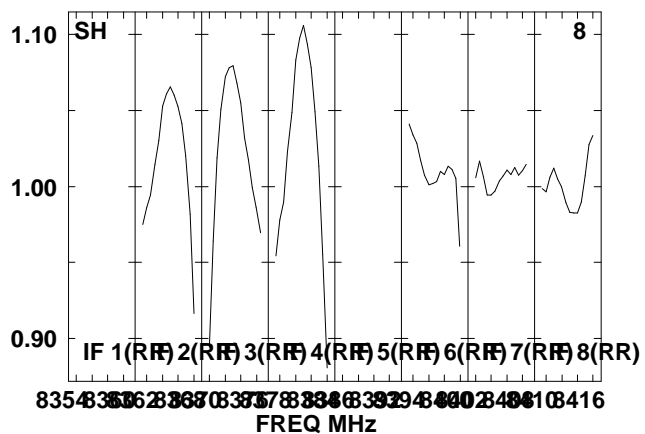
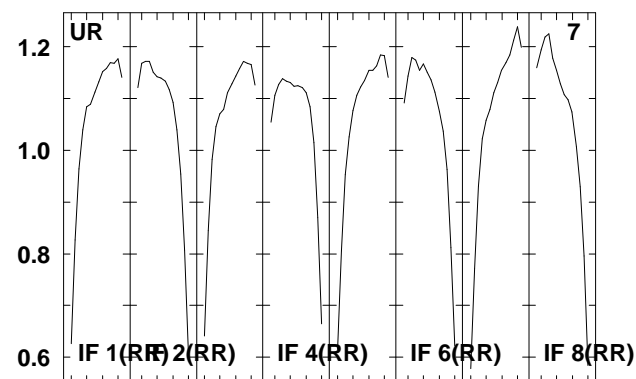
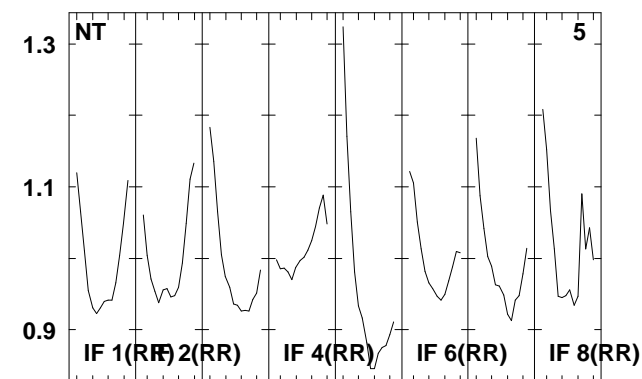
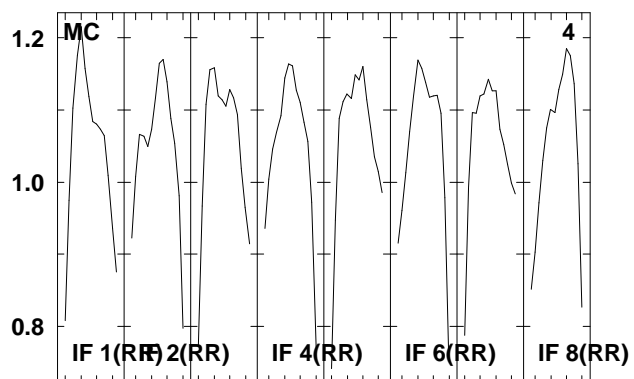
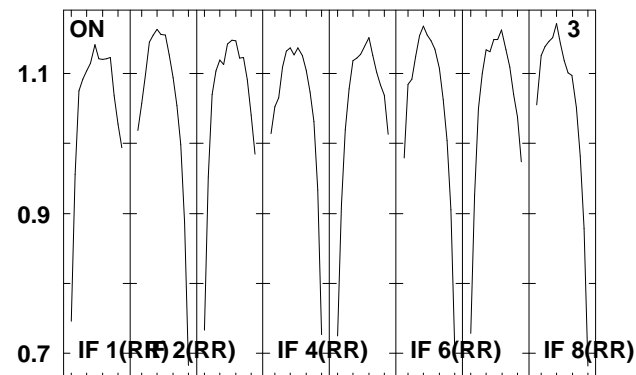
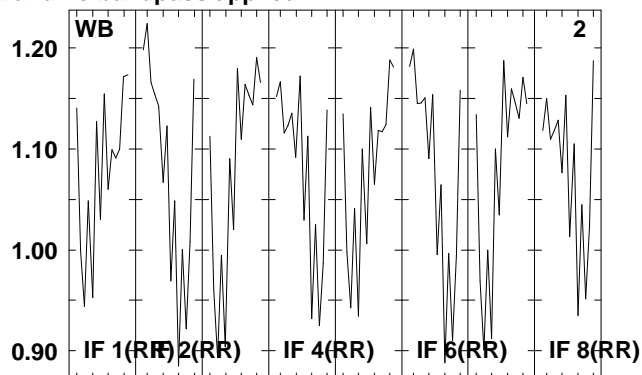
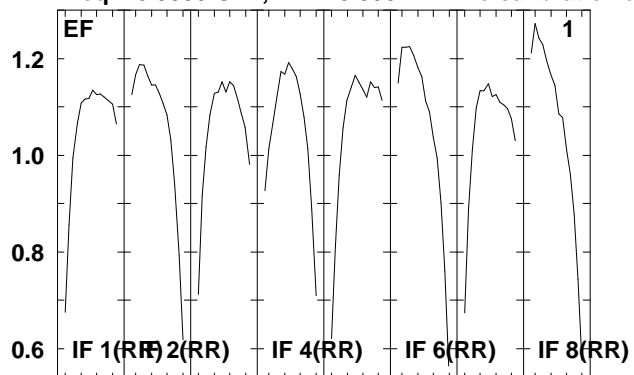

Lower frame: Real Jy

Total-power spectrum Antenna: \*

Timerange: 00/19:56:36 to 00/19:58:04

Plot file version 55 created 05-OCT-2009 09:28:24

NGC6240 EH023B 2.UVDATA.1

Freq = 8.3535 GHz, Bw = 8.000 MH No calibration applied and no bandpass applied

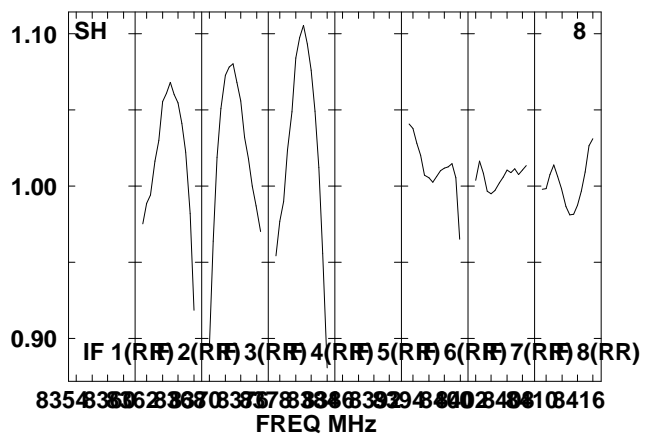
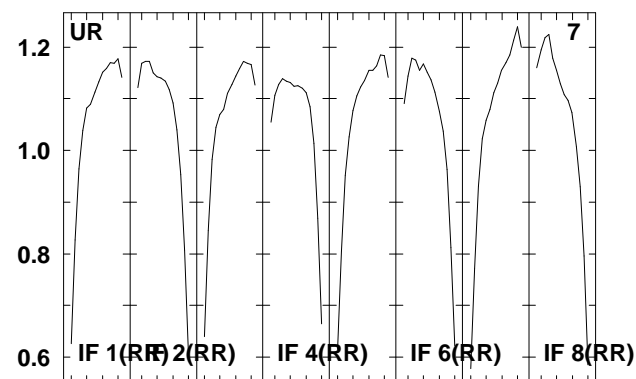
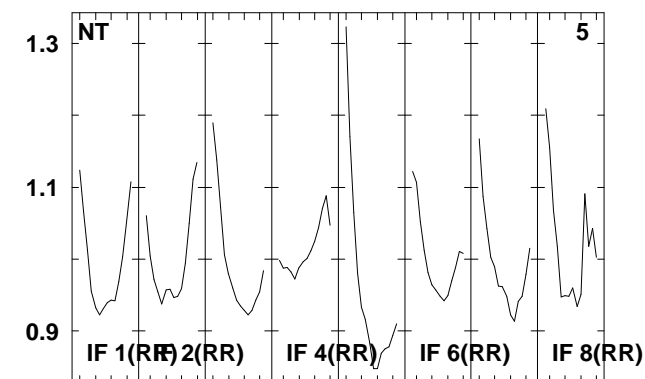
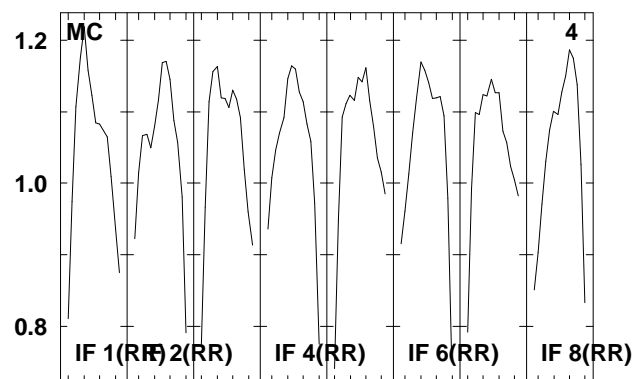
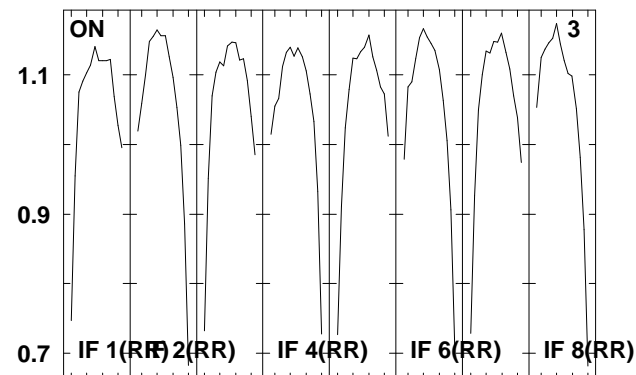
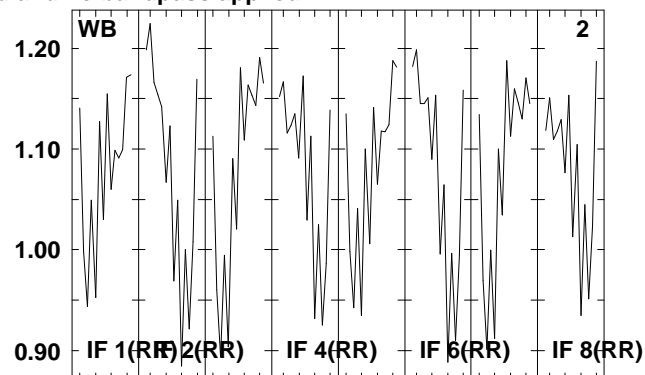
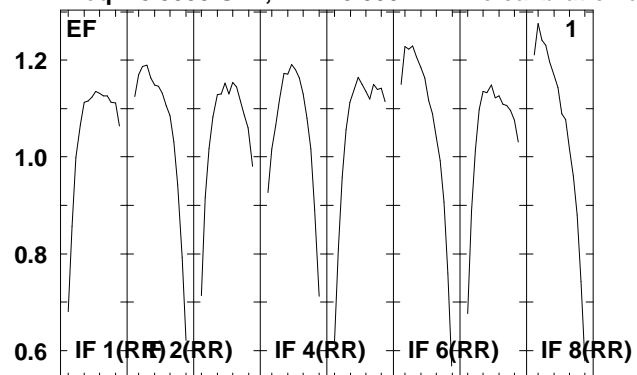

Lower frame: Real Jy

Total-power spectrum Antenna: \*

Timerange: 00/19:58:06 to 00/20:01:34

Plot file version 56 created 05-OCT-2009 09:28:24

J1651+01 EH023B 2.UVDATA.1

Freq = 8.3535 GHz, Bw = 8.000 MH No calibration applied and no bandpass applied

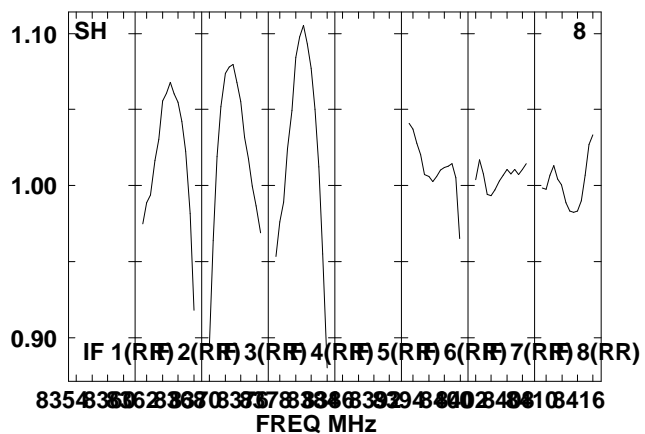
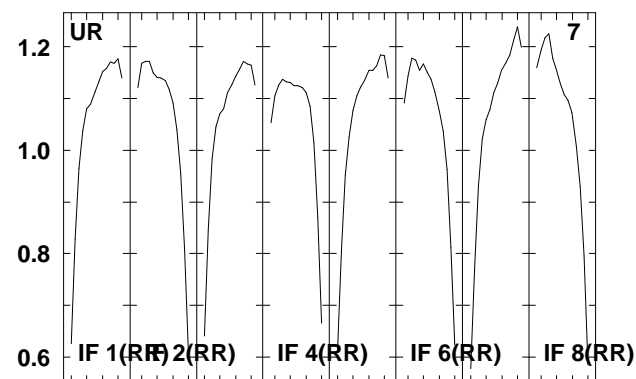
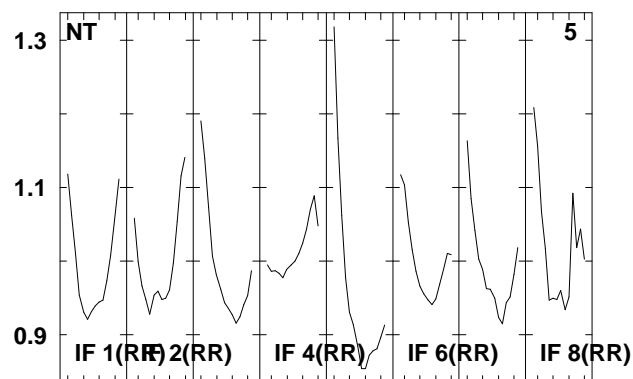
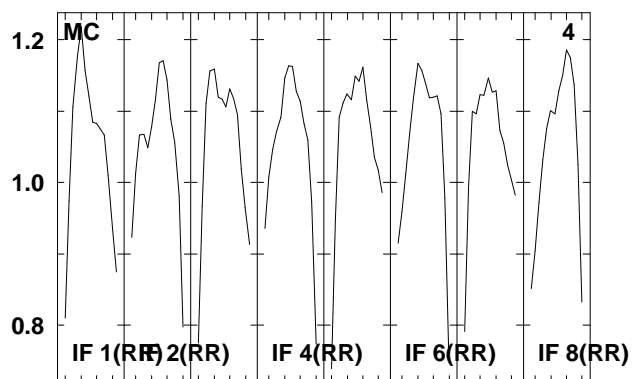
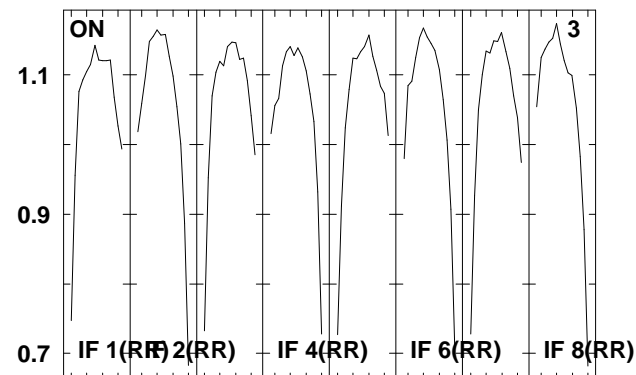
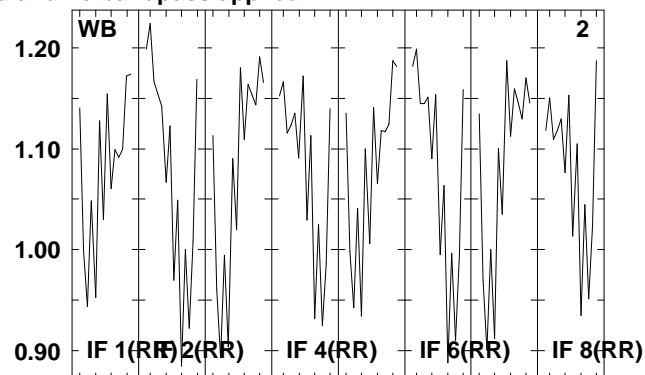
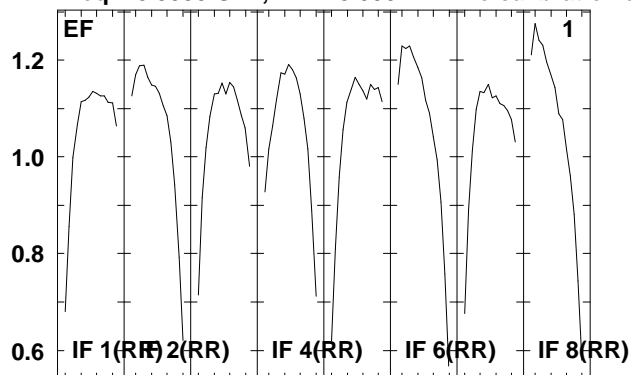

Lower frame: Real Jy

Total-power spectrum Antenna: \*

Timerange: 00/20:01:36 to 00/20:03:04



Plot file version 57 created 05-OCT-2009 09:28:25

NGC6240 EH023B 2.UVDATA.1

Freq = 8.3535 GHz, Bw = 8.000 MH No calibration applied and no bandpass applied

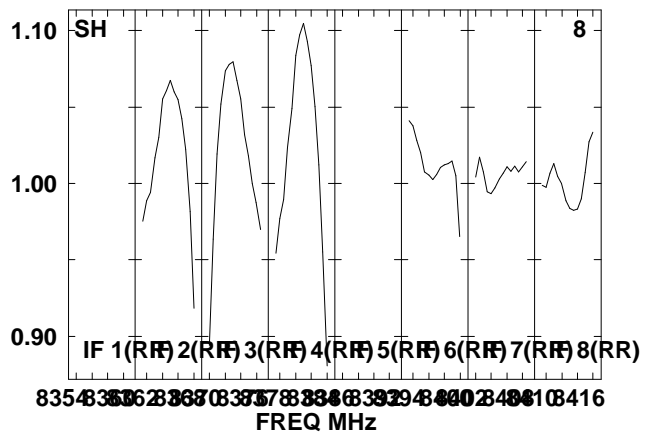
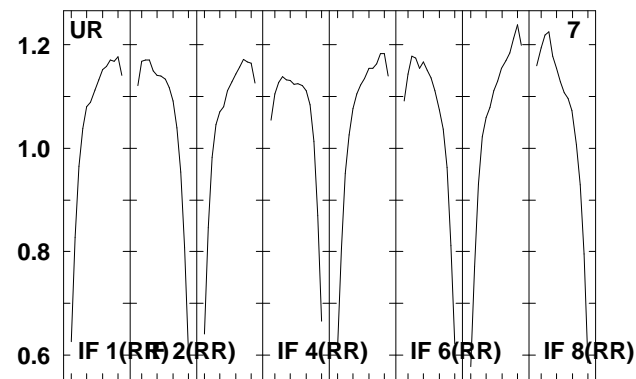
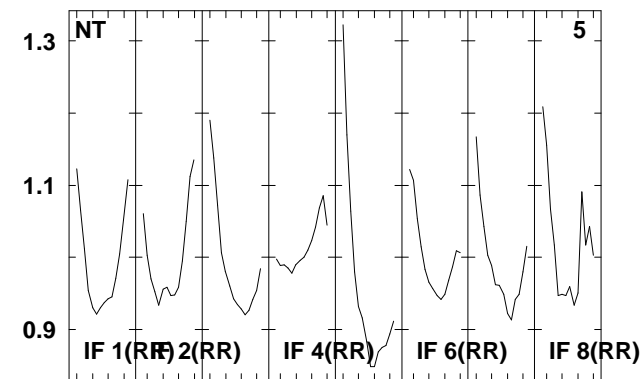
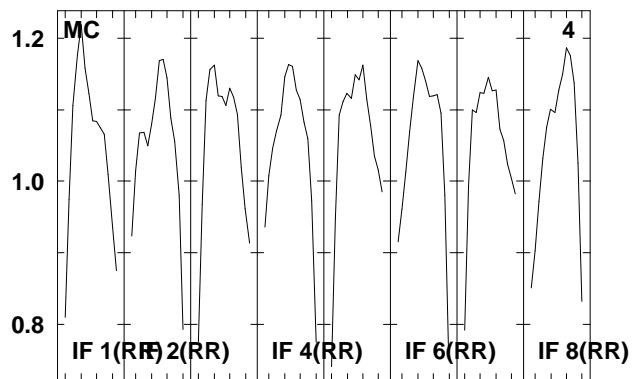
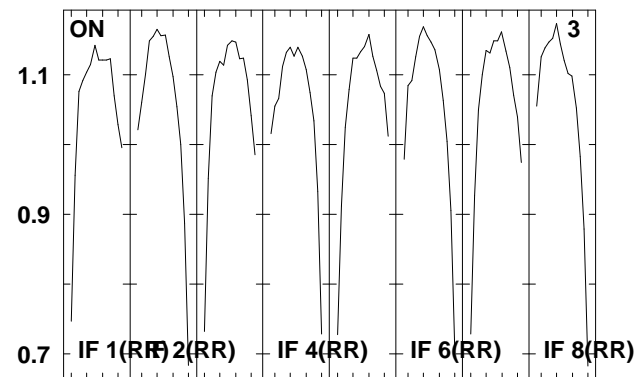
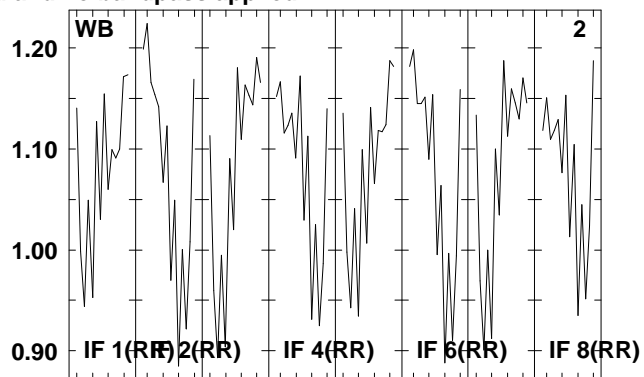
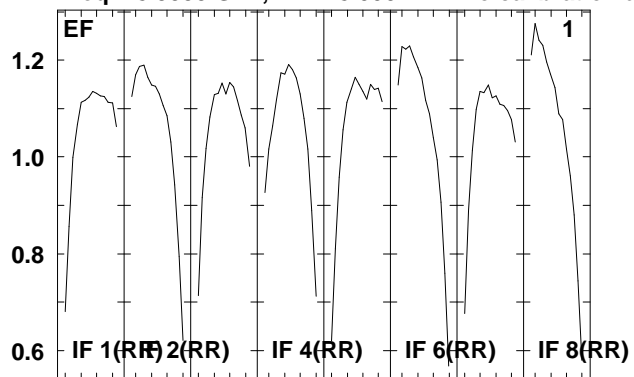

Lower frame: Real Jy

Total-power spectrum Antenna: \*

Timerange: 00/20:03:06 to 00/20:06:34

Plot file version 58 created 05-OCT-2009 09:28:25

J1651+01 EH023B 2.UVDATA.1

Freq = 8.3535 GHz, Bw = 8.000 MH No calibration applied and no bandpass applied

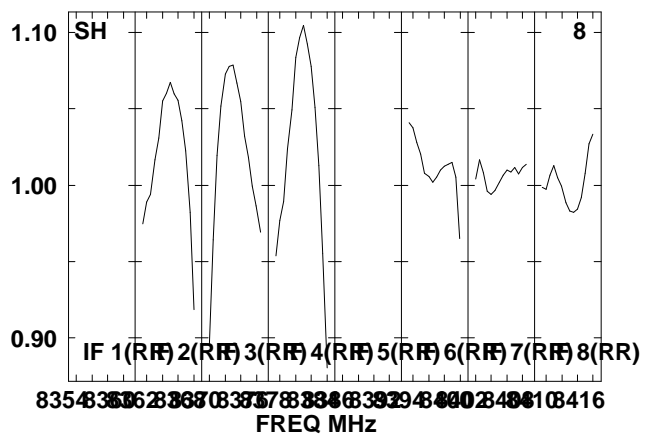
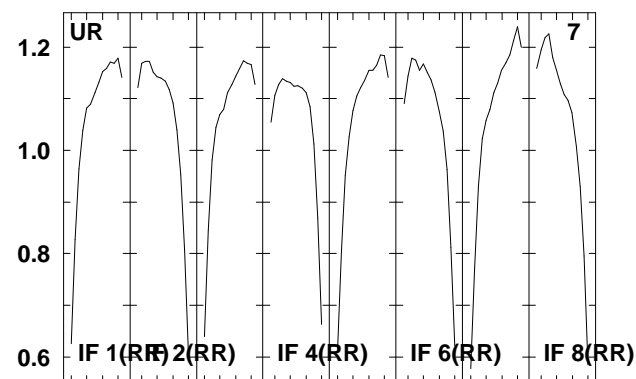
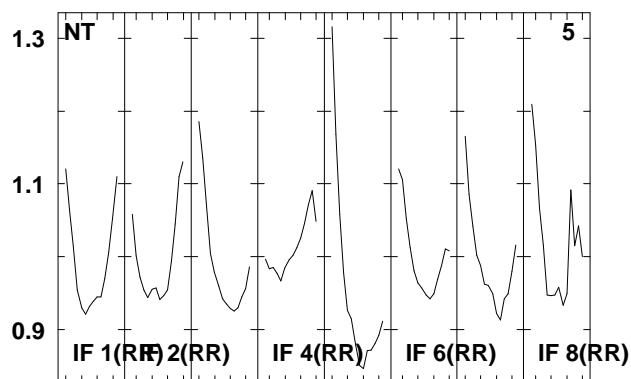
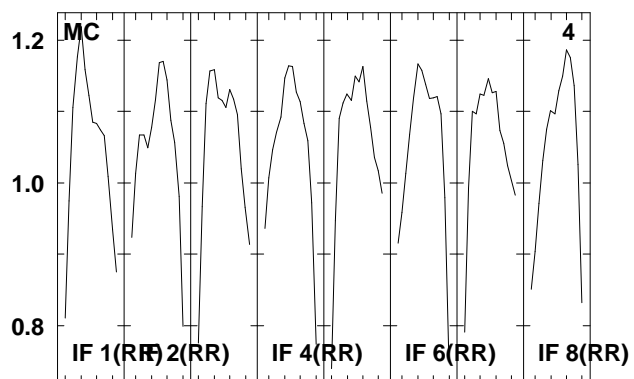
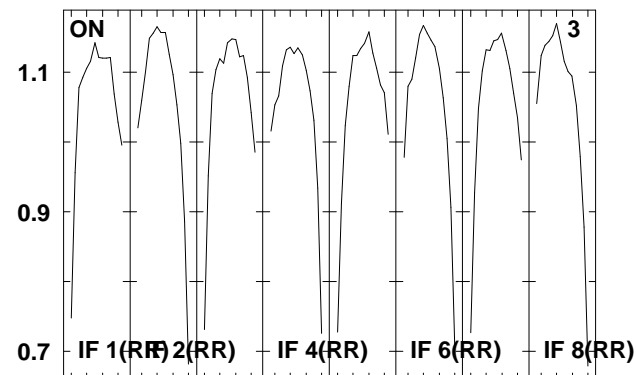
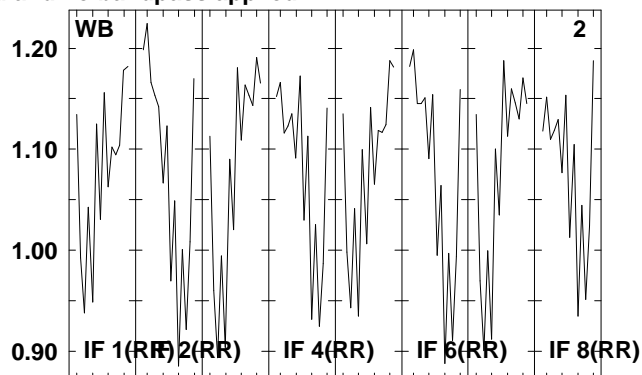
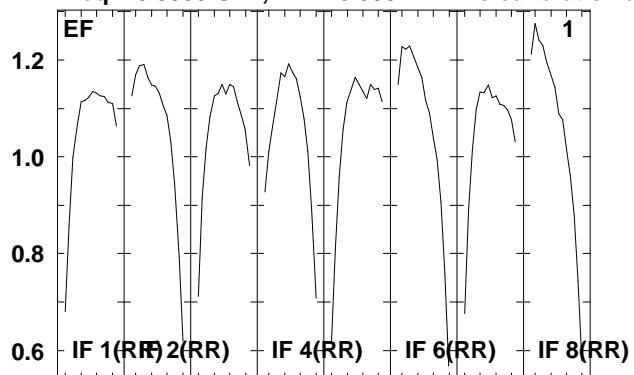

Lower frame: Real Jy

Total-power spectrum Antenna: \*

Timerange: 00/20:07:06 to 00/20:08:34

Plot file version 59 created 05-OCT-2009 09:28:25

NGC6240 EH023B 2.UVDATA.1

Freq = 8.3535 GHz, Bw = 8.000 MH No calibration applied and no bandpass applied

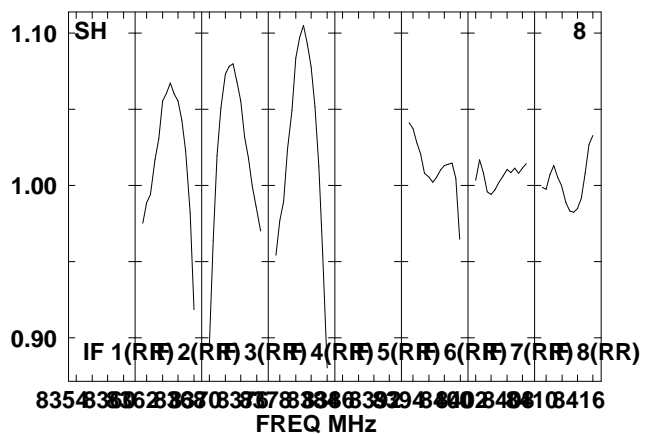
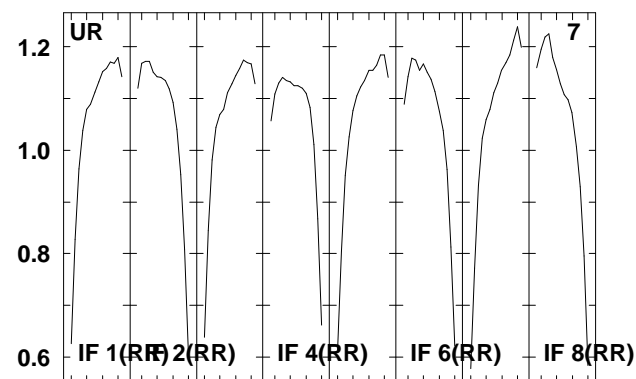
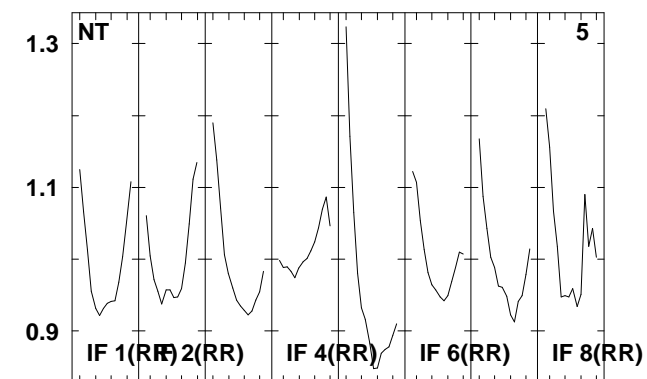
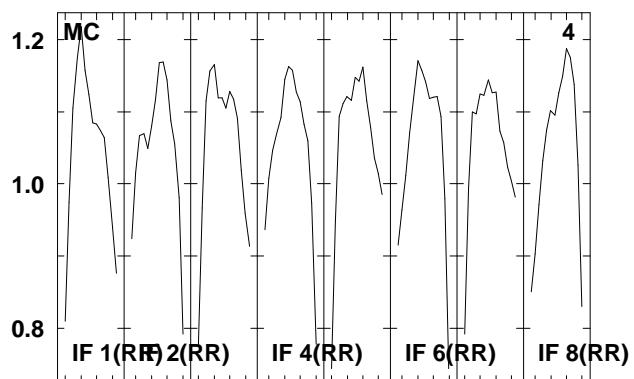
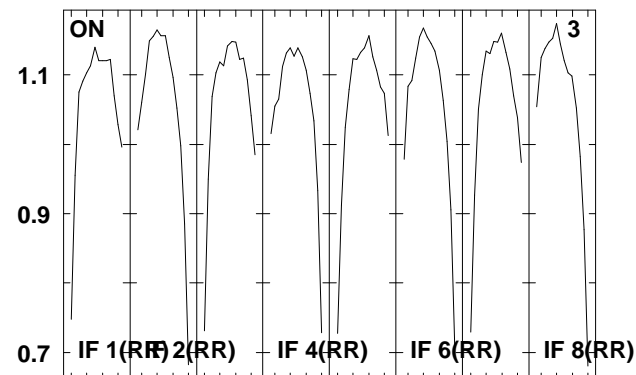
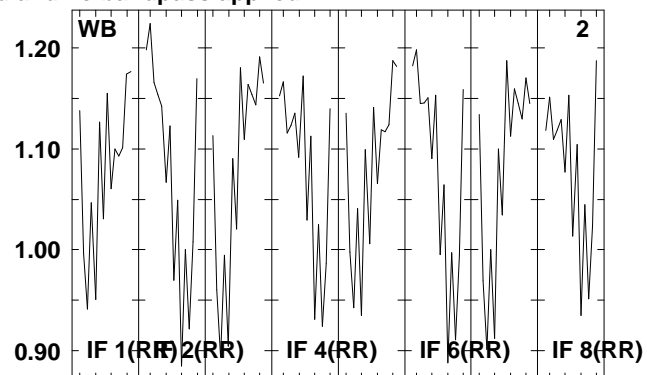
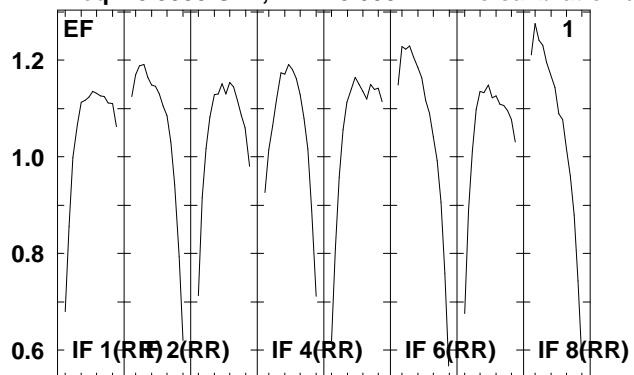

Lower frame: Real Jy

Total-power spectrum Antenna: \*

Timerange: 00/20:08:36 to 00/20:12:04

Plot file version 60 created 05-OCT-2009 09:28:25

J1651+01 EH023B 2.UVDATA.1

Freq = 8.3535 GHz, Bw = 8.000 MH No calibration applied and no bandpass applied

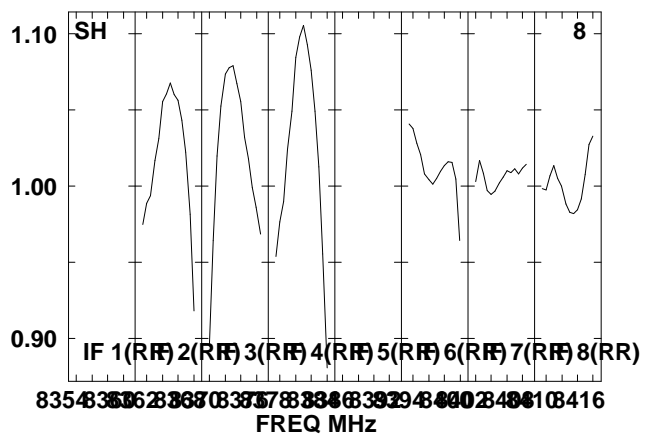
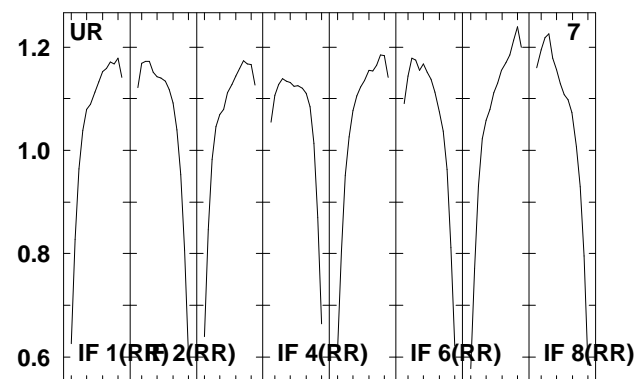
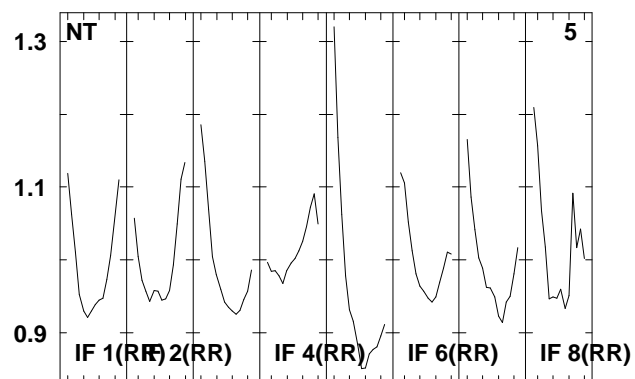
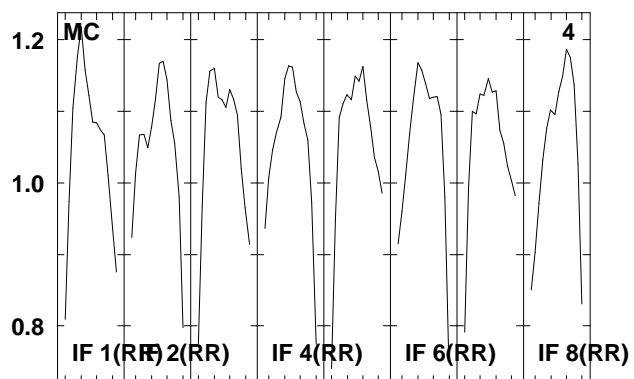
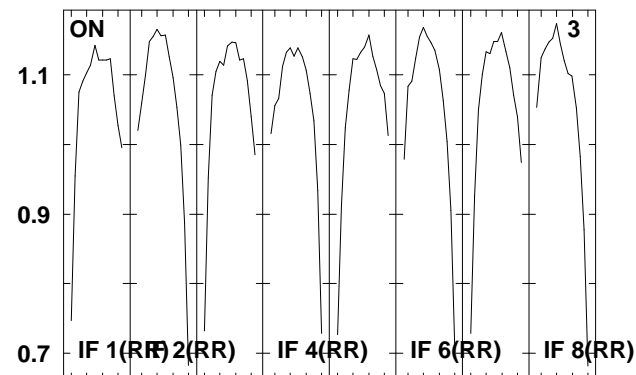
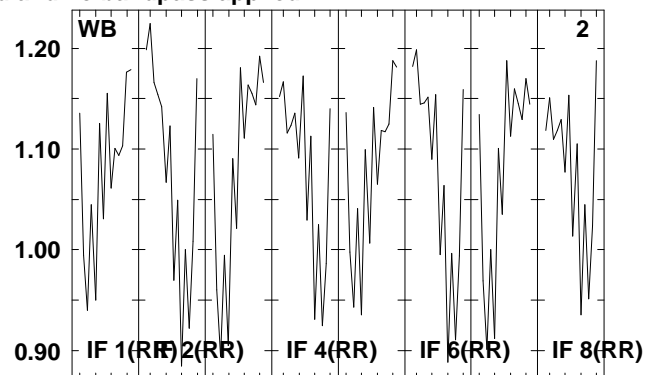
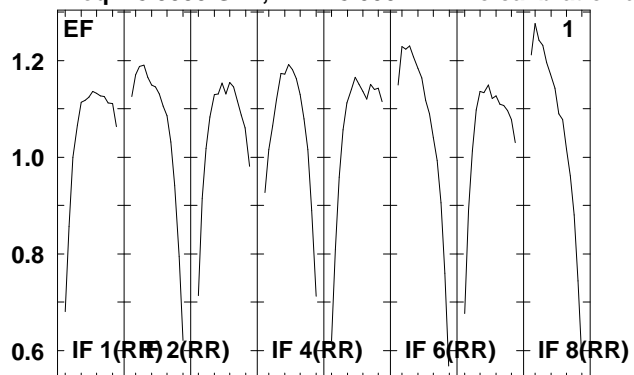

Lower frame: Real Jy

Total-power spectrum Antenna: \*

Timerange: 00/20:12:06 to 00/20:13:34

Plot file version 61 created 05-OCT-2009 09:28:25

NGC6240 EH023B 2.UVDATA.1

Freq = 8.3535 GHz, Bw = 8.000 MH No calibration applied and no bandpass applied

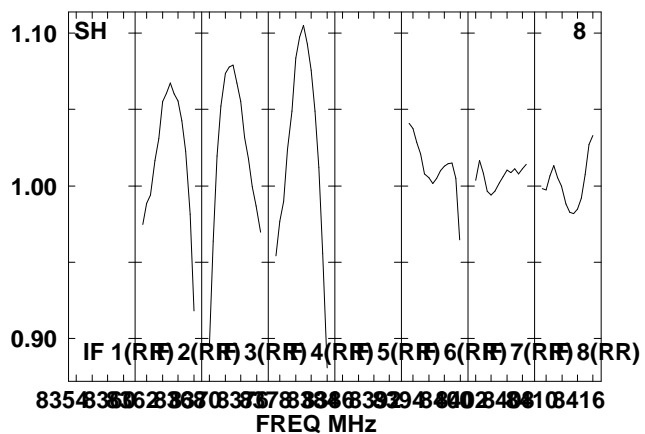
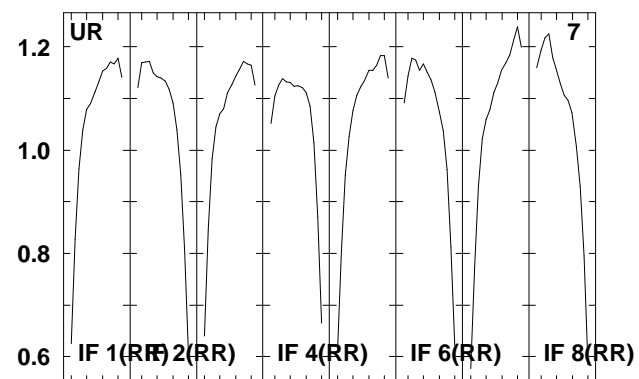
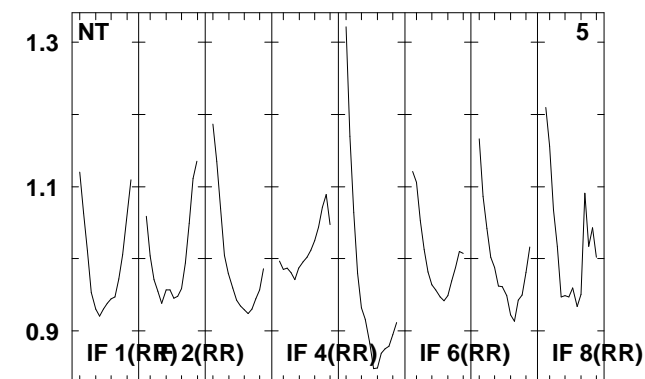
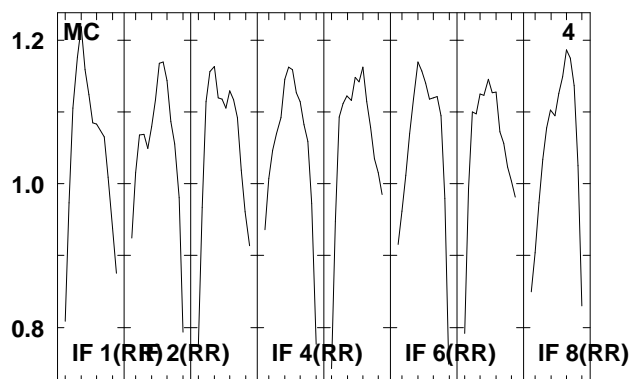
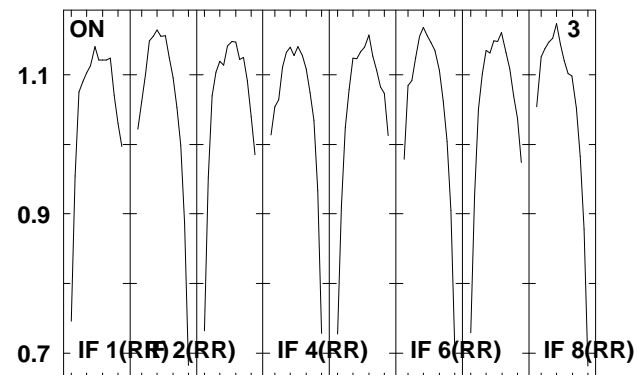
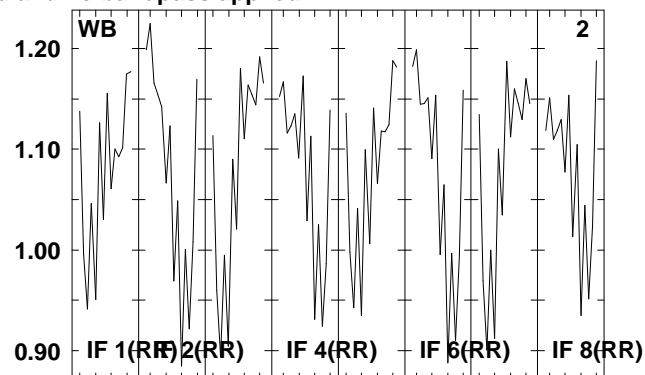
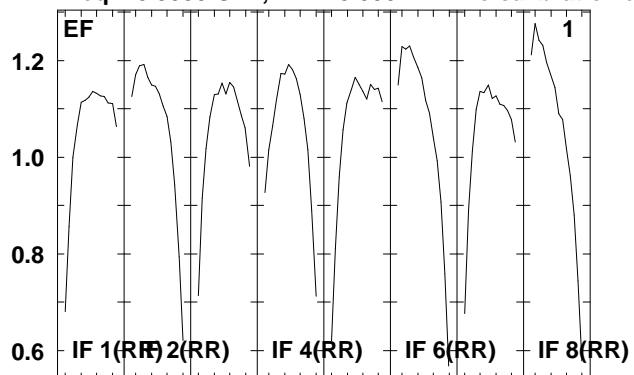

Lower frame: Real Jy

Total-power spectrum Antenna: \*

Timerange: 00/20:13:36 to 00/20:17:04

Plot file version 62 created 05-OCT-2009 09:28:25

J1651+01 EH023B 2.UVDATA.1

Freq = 8.3535 GHz, Bw = 8.000 MH No calibration applied and no bandpass applied

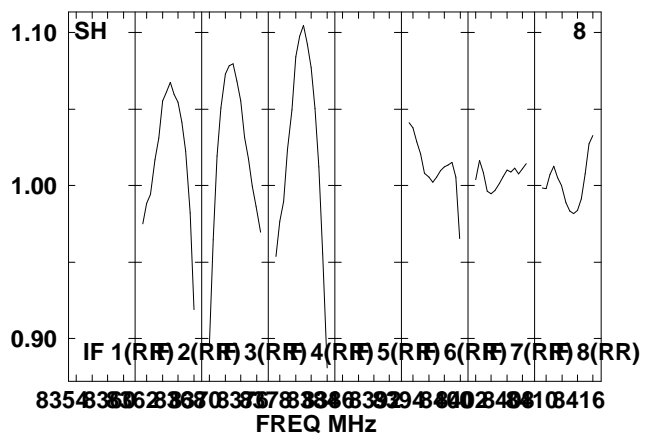
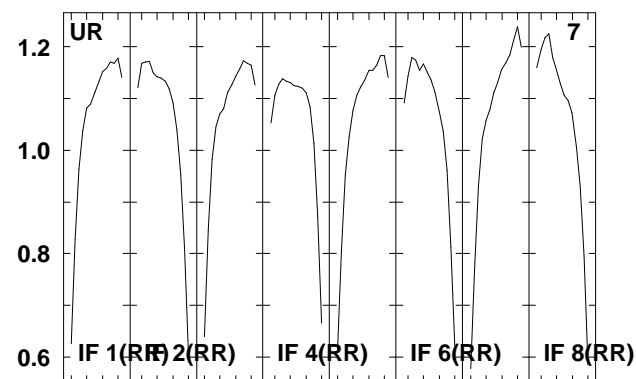
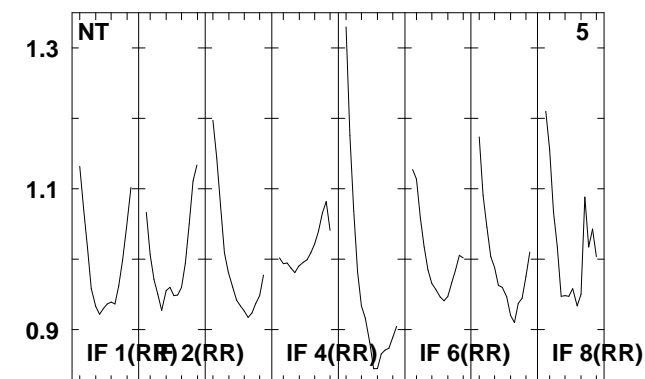
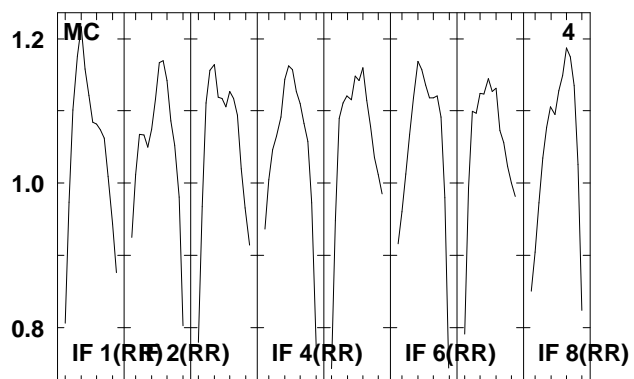
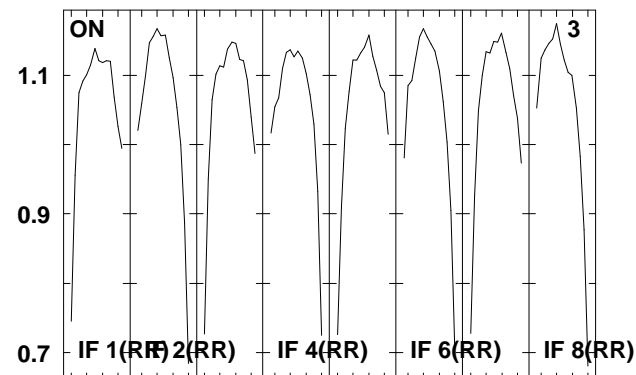
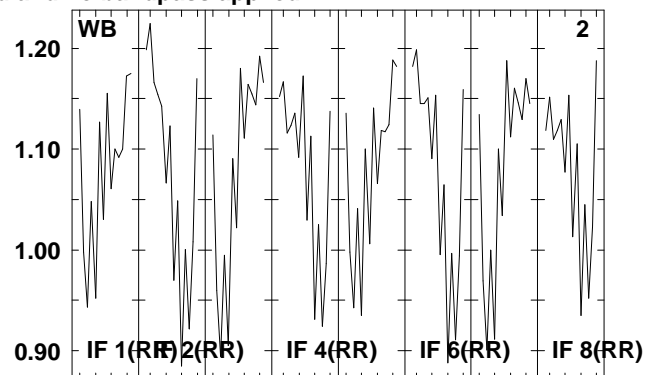
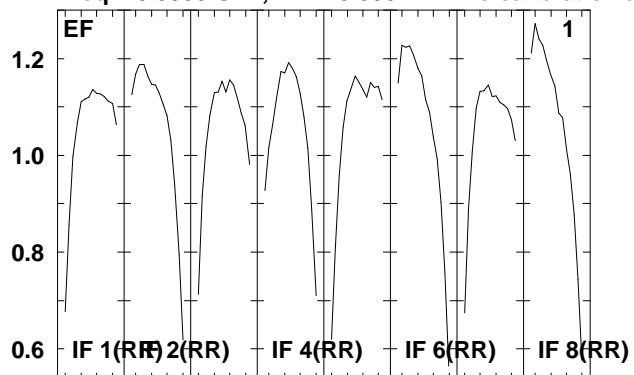

Lower frame: Real Jy  
Total-power spectrum Antenna: \*  
Timerange: 00/20:17:36 to 00/20:19:04

Plot file version 63 created 05-OCT-2009 09:28:26

NGC6240 EH023B 2.UVDATA.1

Freq = 8.3535 GHz, Bw = 8.000 MH No calibration applied and no bandpass applied

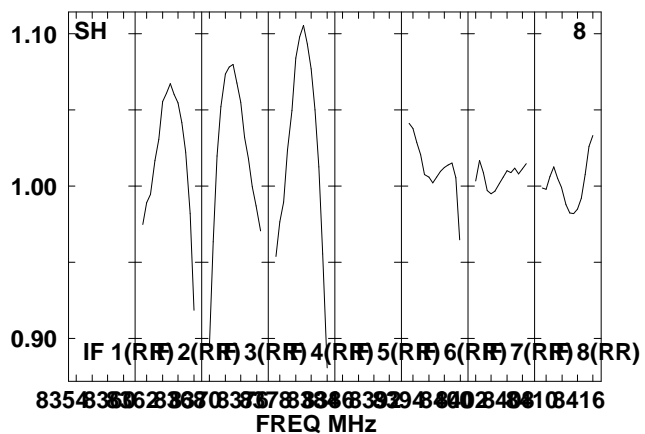
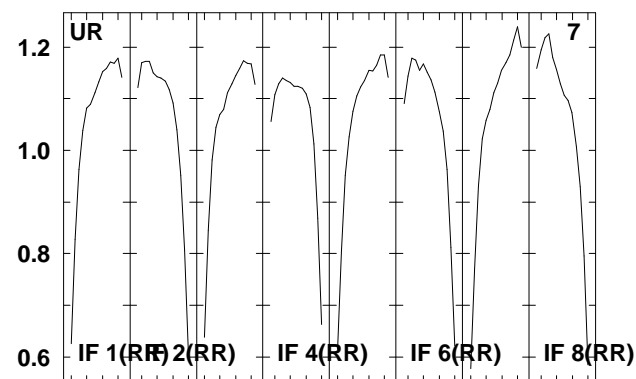
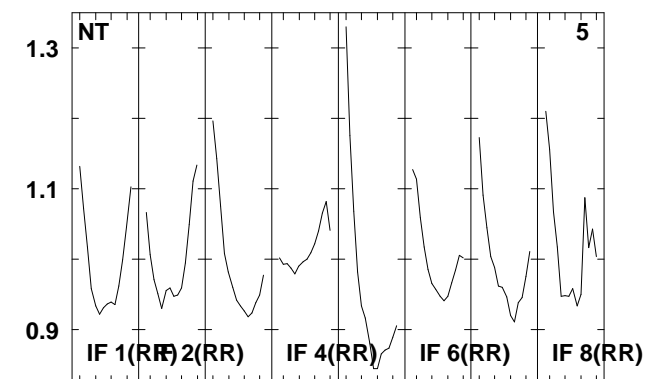
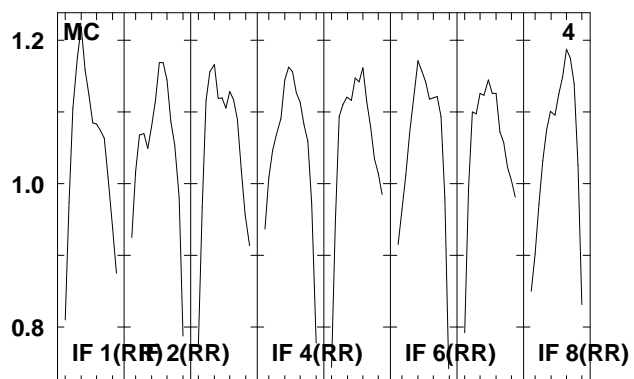
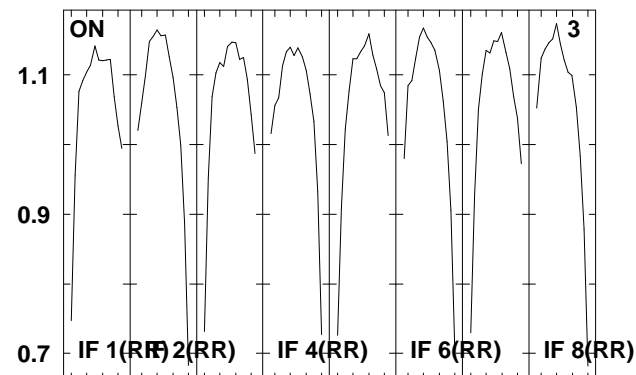
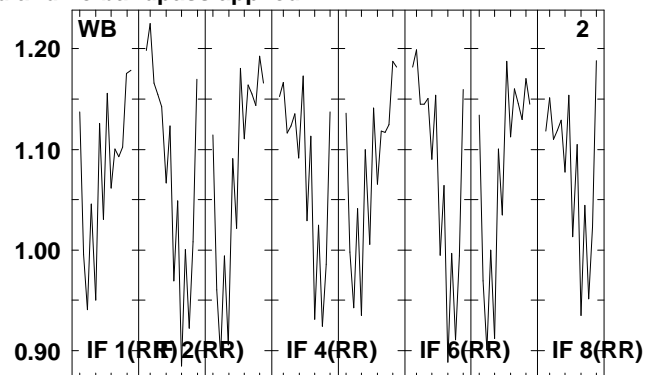
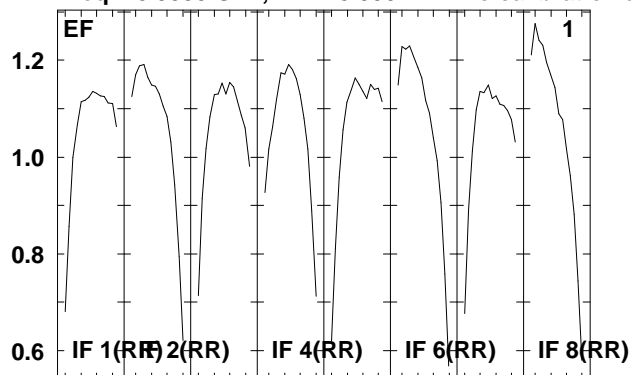

Lower frame: Real Jy

Total-power spectrum Antenna: \*

Timerange: 00/20:19:06 to 00/20:22:34

Plot file version 64 created 05-OCT-2009 09:28:26

J1651+01 EH023B 2.UVDATA.1

Freq = 8.3535 GHz, Bw = 8.000 MH No calibration applied and no bandpass applied

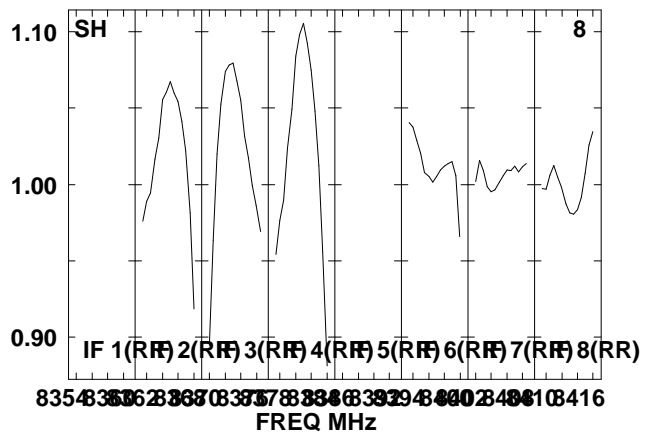
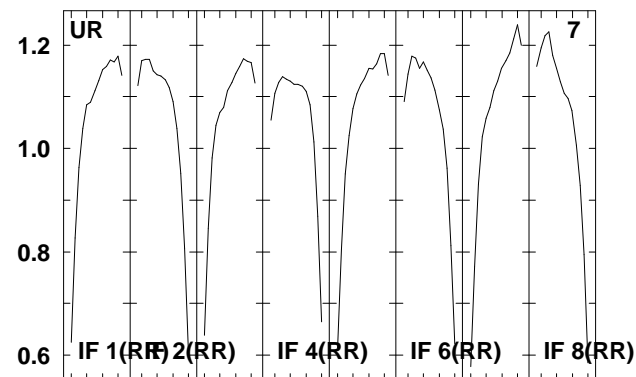
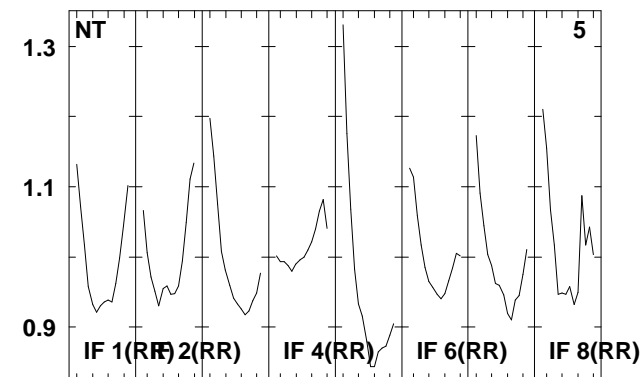
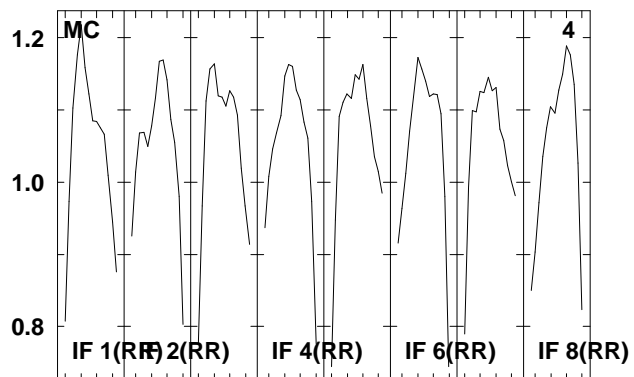
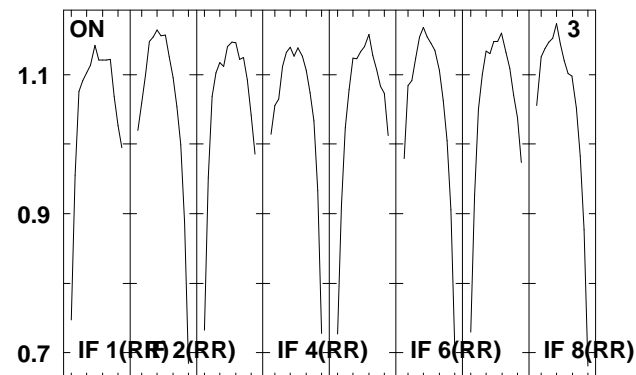
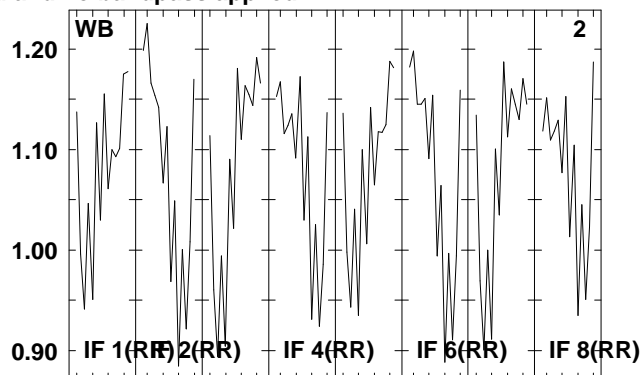
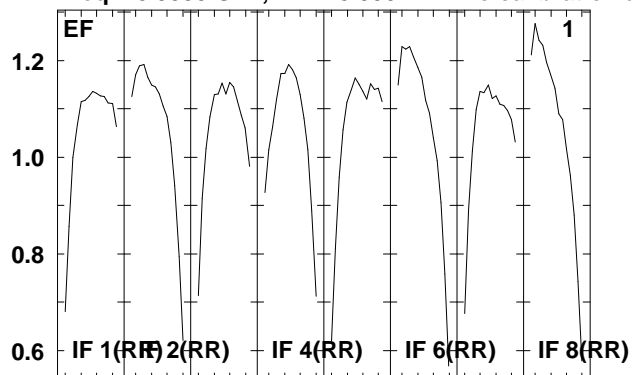

Lower frame: Real Jy

Total-power spectrum Antenna: \*

Timerange: 00/20:22:36 to 00/20:24:04



Plot file version 65 created 05-OCT-2009 09:28:26

NGC6240 EH023B 2.UVDATA.1

Freq = 8.3535 GHz, Bw = 8.000 MH No calibration applied and no bandpass applied

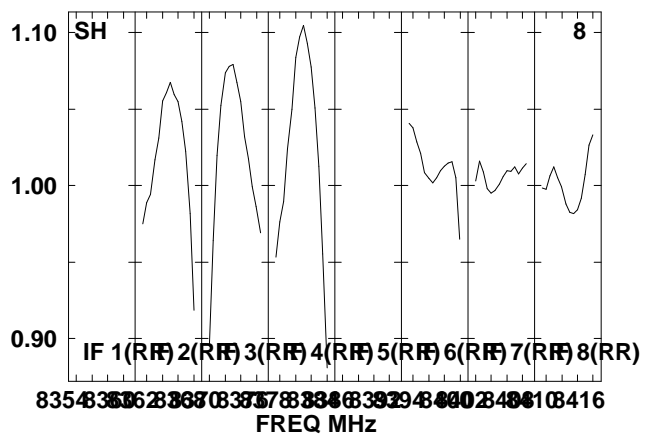
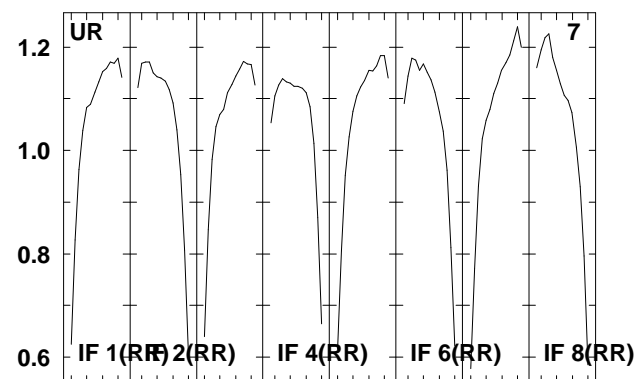
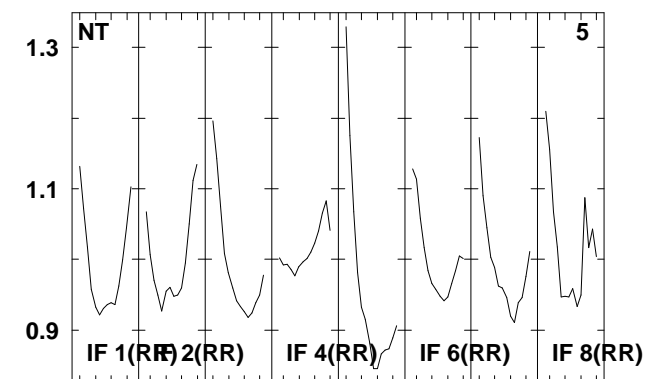
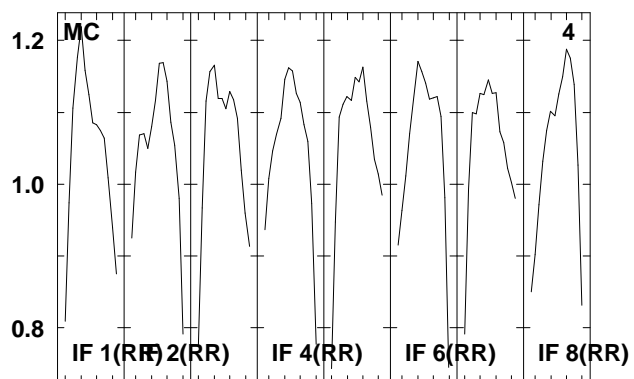
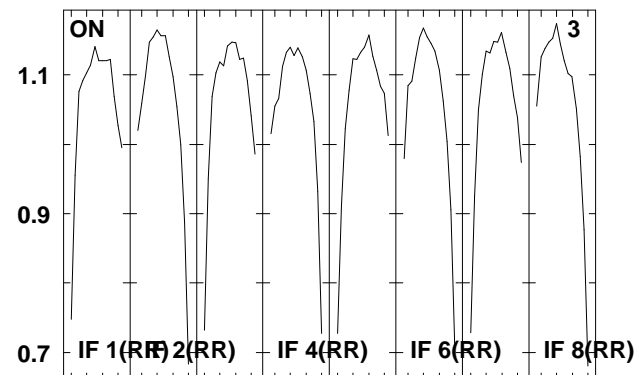
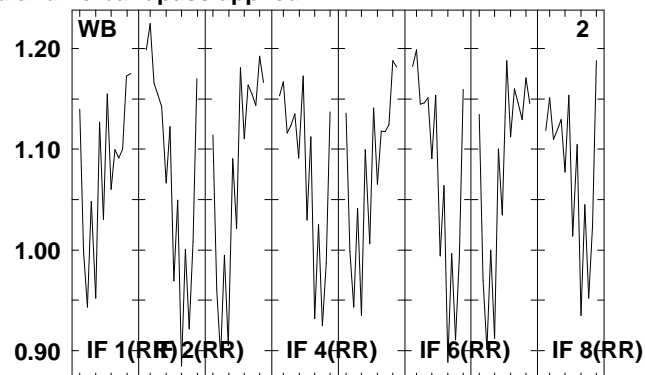
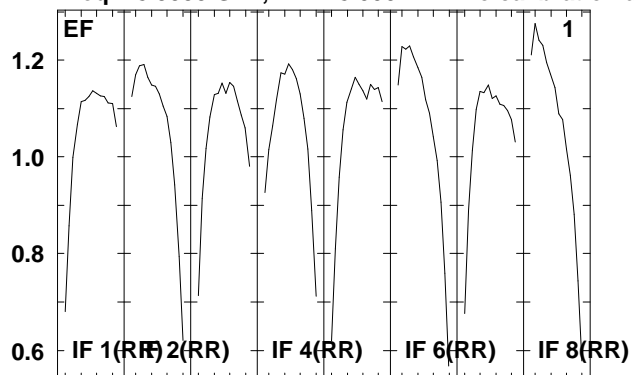

Lower frame: Real Jy

Total-power spectrum Antenna: \*

Timerange: 00/20:24:06 to 00/20:27:34

Plot file version 66 created 05-OCT-2009 09:28:26

J1651+01 EH023B 2.UVDATA.1

Freq = 8.3535 GHz, Bw = 8.000 MH No calibration applied and no bandpass applied

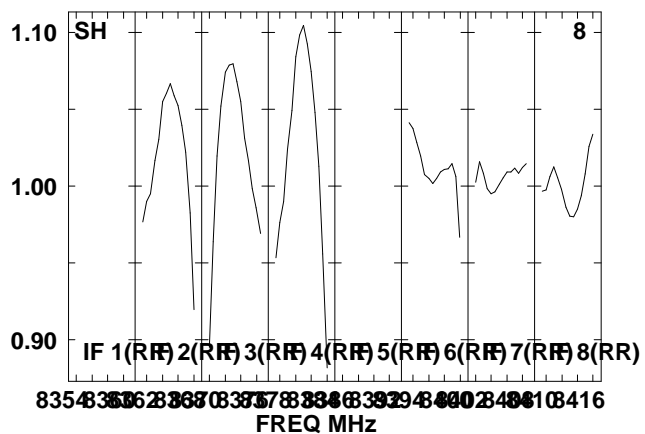
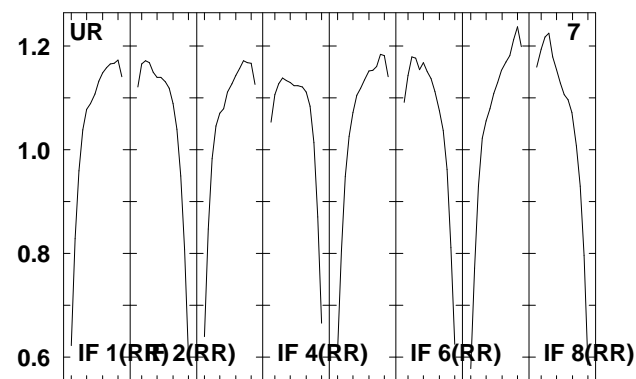
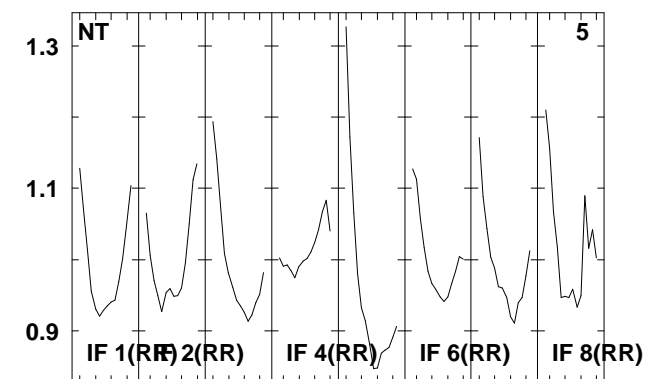
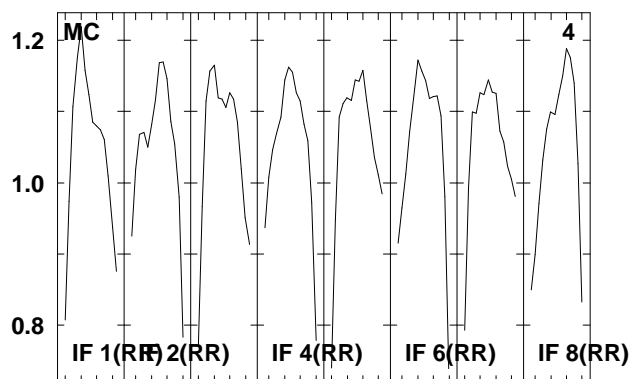
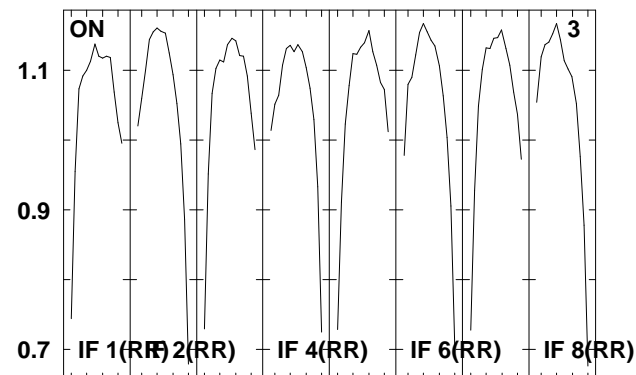
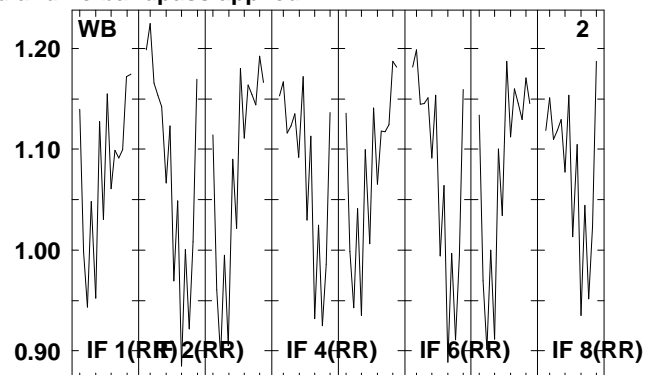
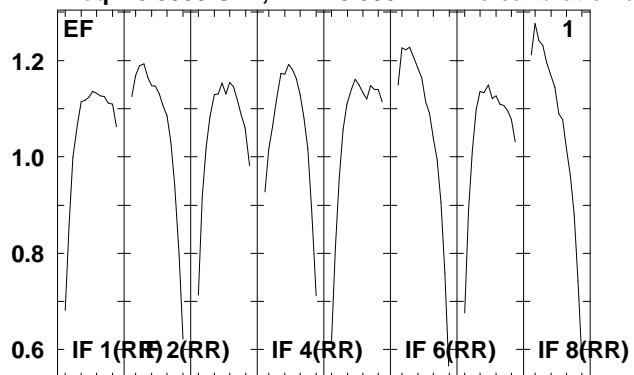

Lower frame: Real Jy

Total-power spectrum Antenna: \*

Timerange: 00/20:28:06 to 00/20:29:34

Plot file version 67 created 05-OCT-2009 09:28:26

NGC6240 EH023B 2.UVDATA.1

Freq = 8.3535 GHz, Bw = 8.000 MH No calibration applied and no bandpass applied

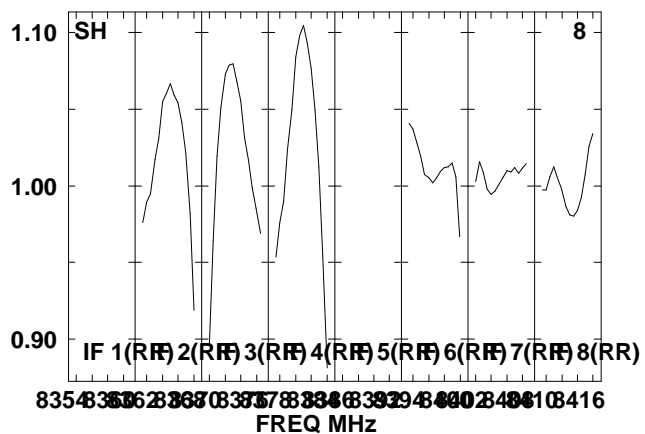
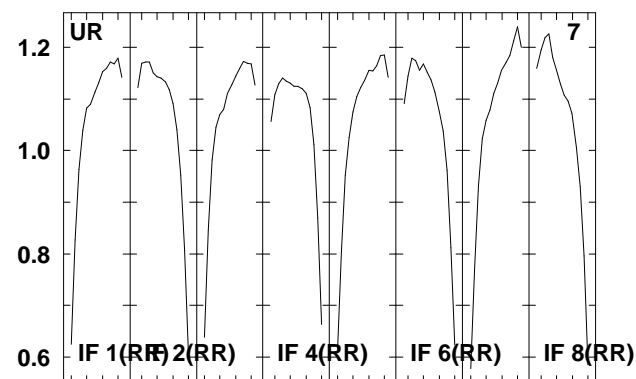
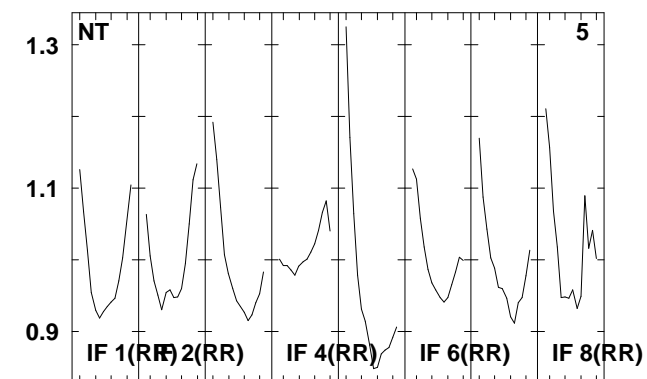
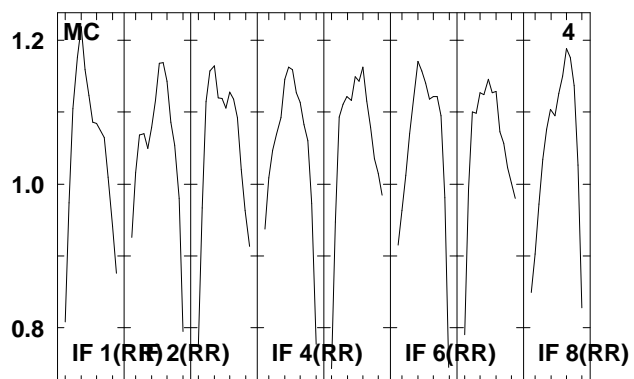
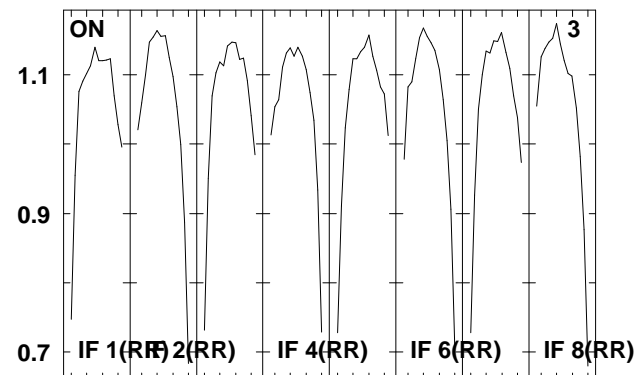
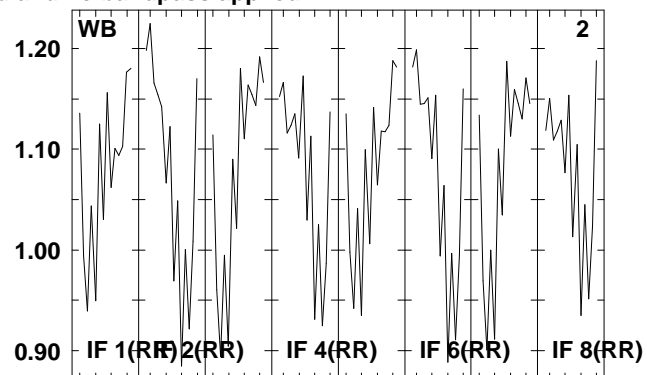
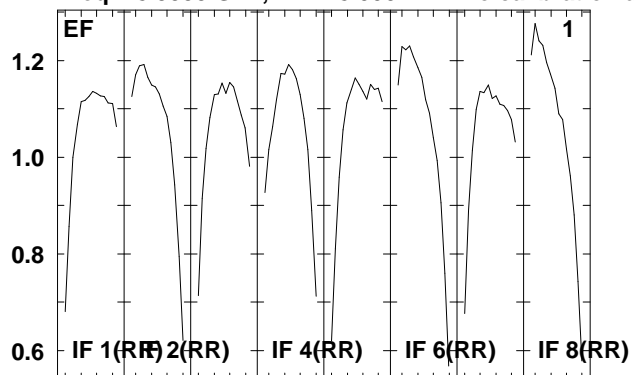

Lower frame: Real Jy

Total-power spectrum Antenna: \*

Timerange: 00/20:29:36 to 00/20:33:04

Plot file version 68 created 05-OCT-2009 09:28:27

J1651+01 EH023B 2.UVDATA.1

Freq = 8.3535 GHz, Bw = 8.000 MH No calibration applied and no bandpass applied

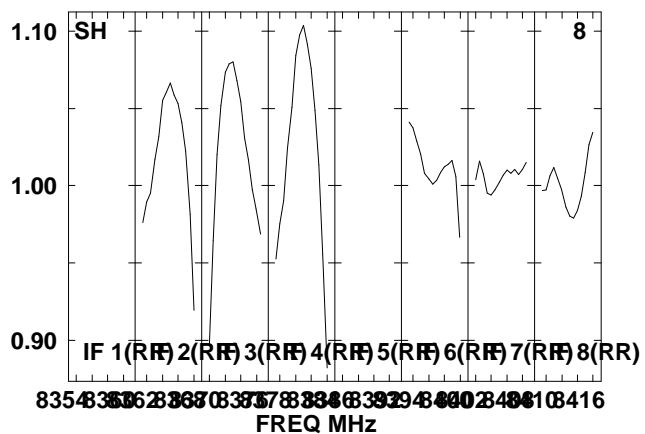
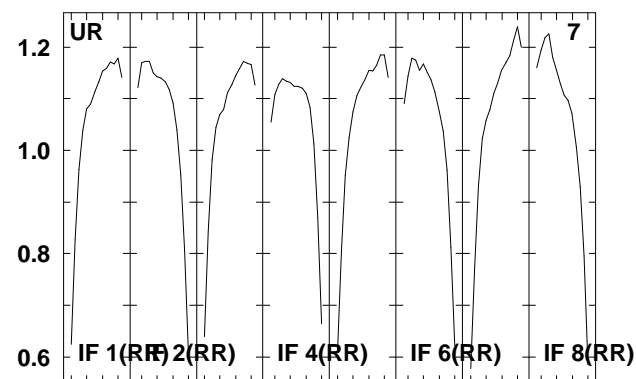
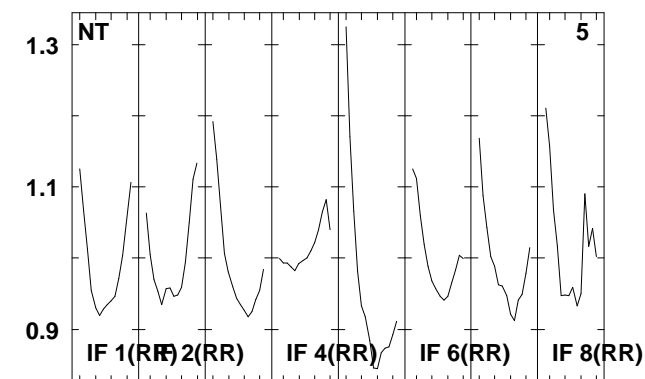
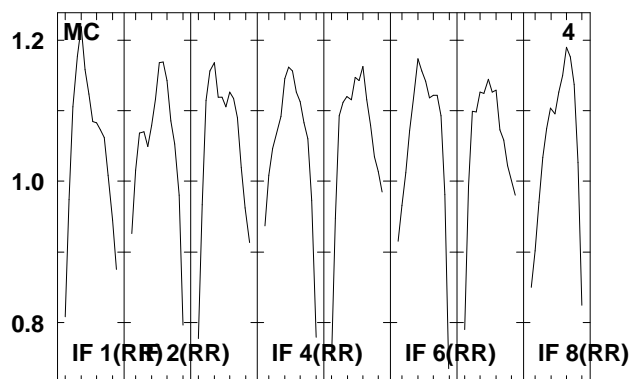
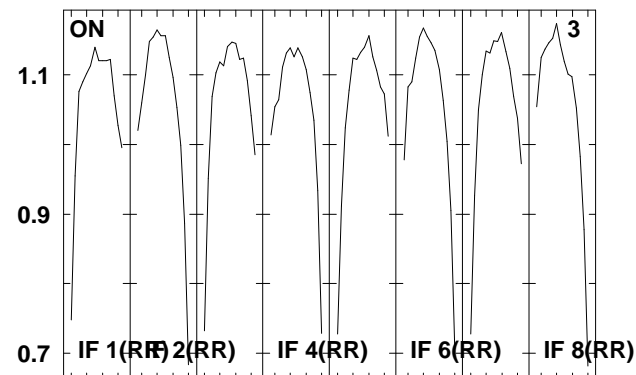
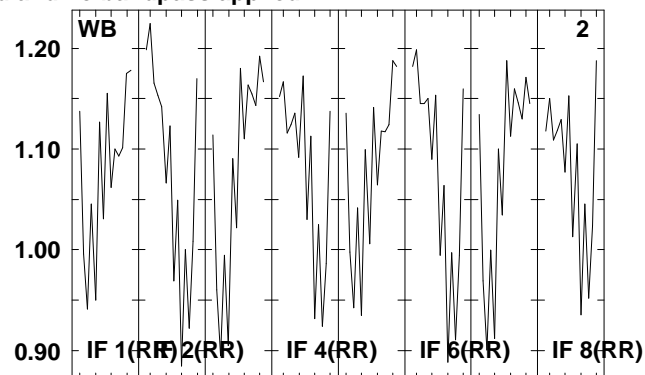
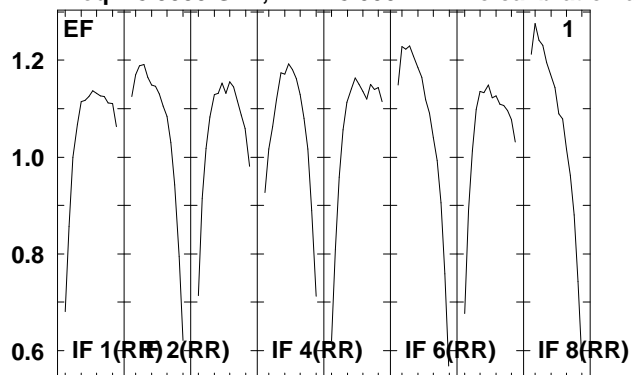

Lower frame: Real Jy

Total-power spectrum Antenna: \*

Timerange: 00/20:33:06 to 00/20:34:34

Plot file version 69 created 05-OCT-2009 09:28:27

NGC6240 EH023B 2.UVDATA.1

Freq = 8.3535 GHz, Bw = 8.000 MH No calibration applied and no bandpass applied

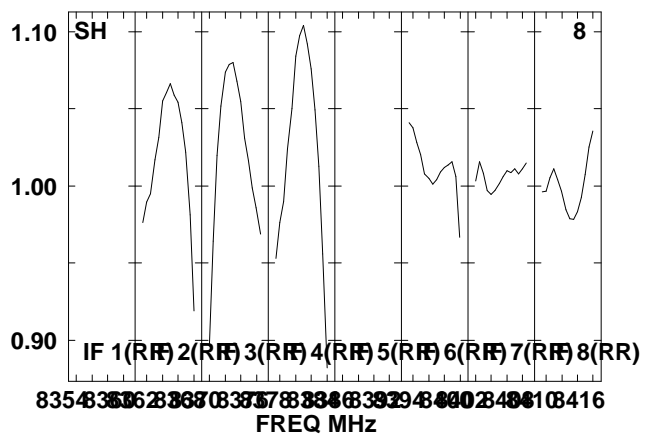
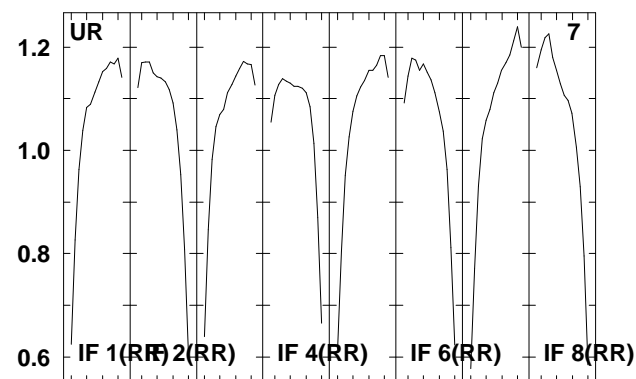
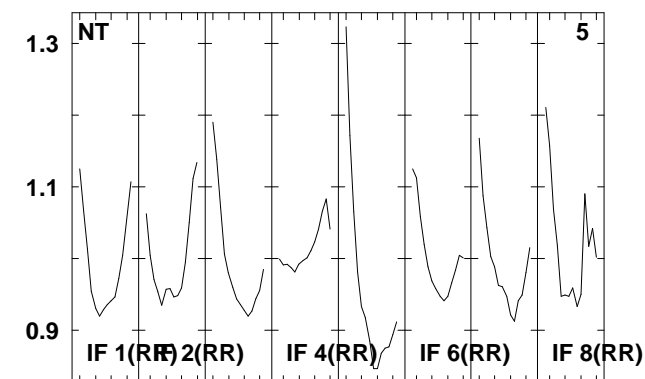
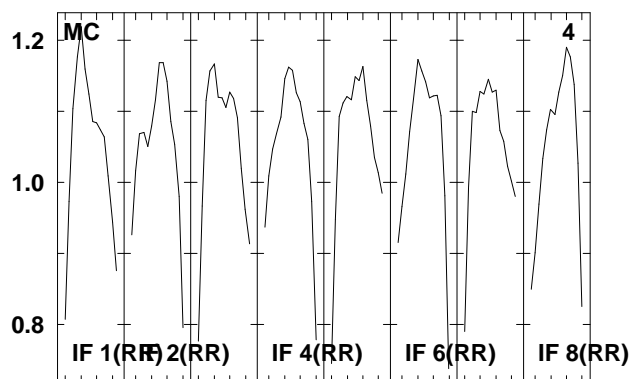
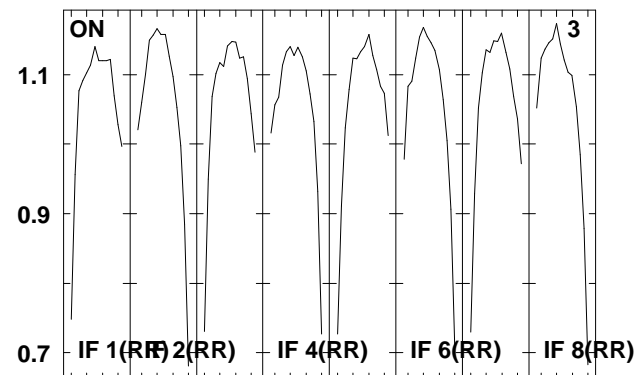
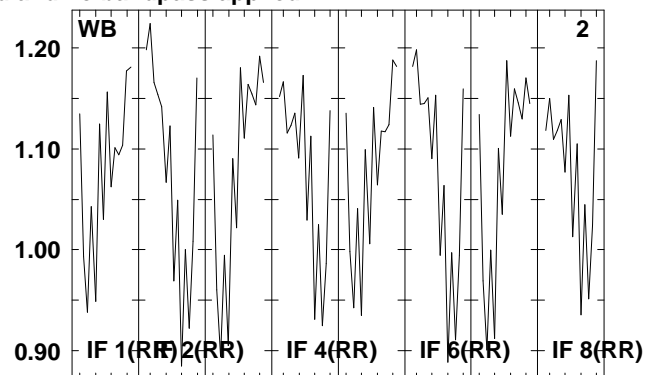
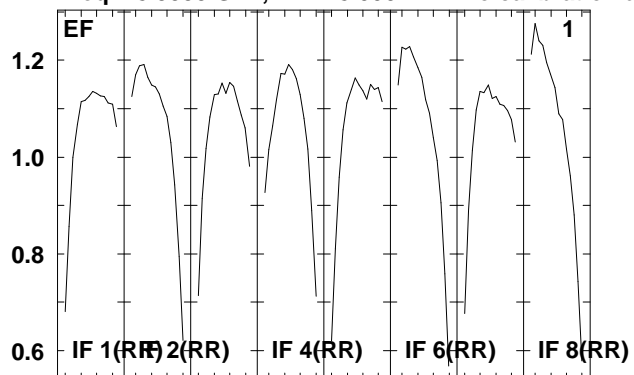

Lower frame: Real Jy

Total-power spectrum Antenna: \*

Timerange: 00/20:34:36 to 00/20:38:04

Plot file version 70 created 05-OCT-2009 09:28:27

J1651+01 EH023B 2.UVDATA.1

Freq = 8.3535 GHz, Bw = 8.000 MH No calibration applied and no bandpass applied

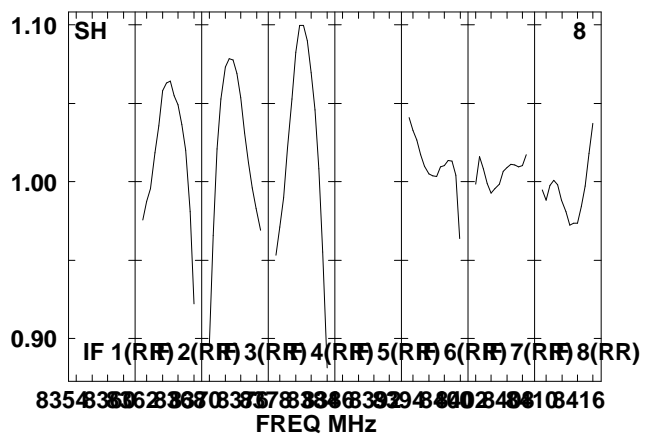
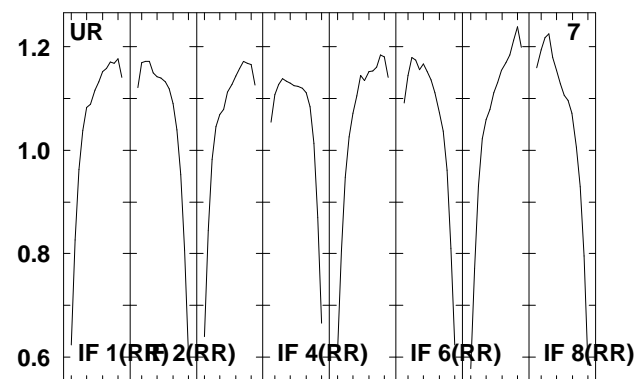
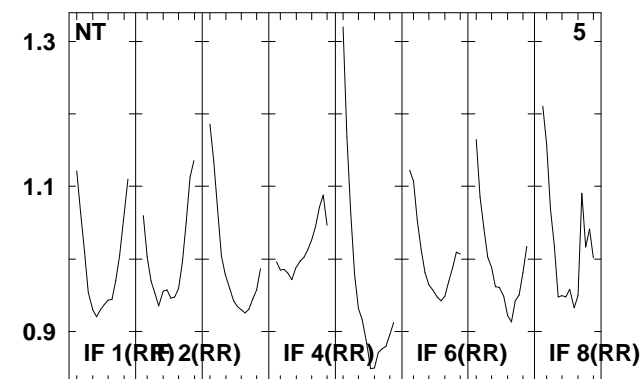
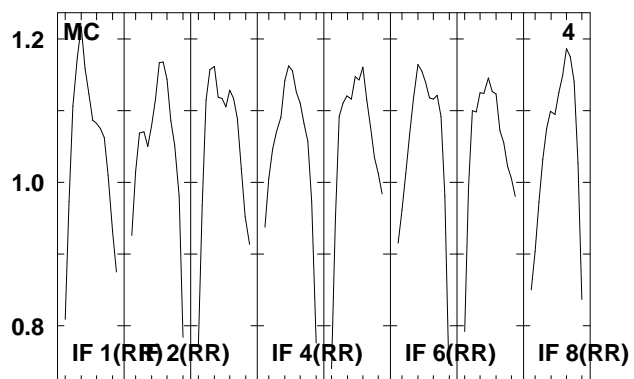
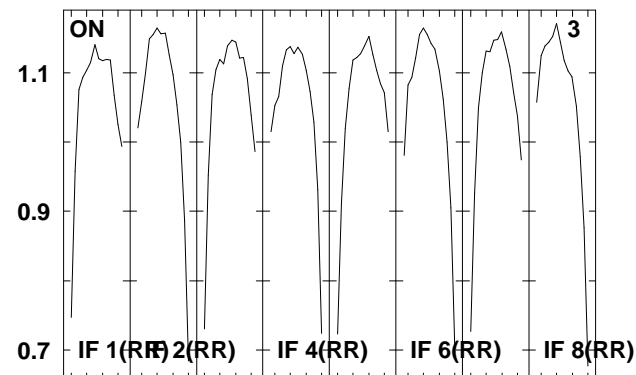
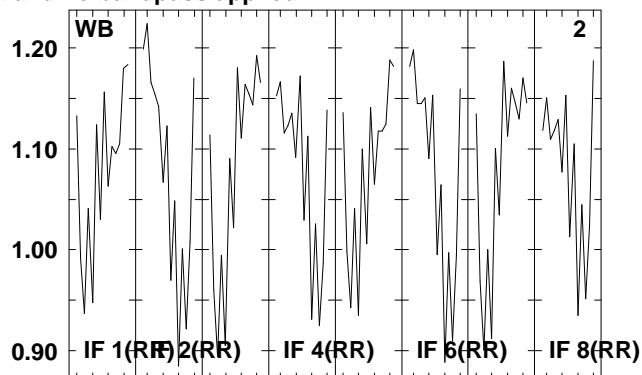
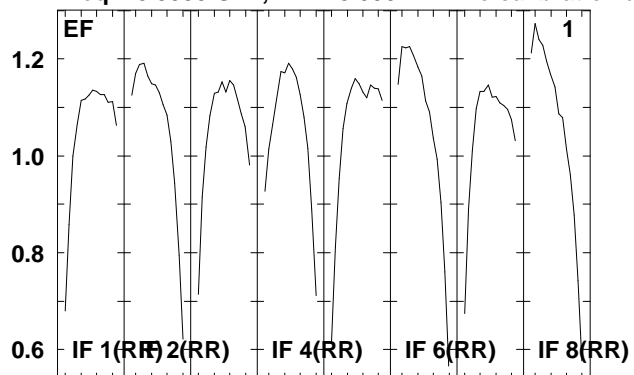

Lower frame: Real Jy

Total-power spectrum Antenna: \*

Timerange: 00/20:38:36 to 00/20:40:04

Plot file version 71 created 05-OCT-2009 09:28:27

3C345 EH023B 2.UVDATA.1

Freq = 8.3535 GHz, Bw = 8.000 MH No calibration applied and no bandpass applied

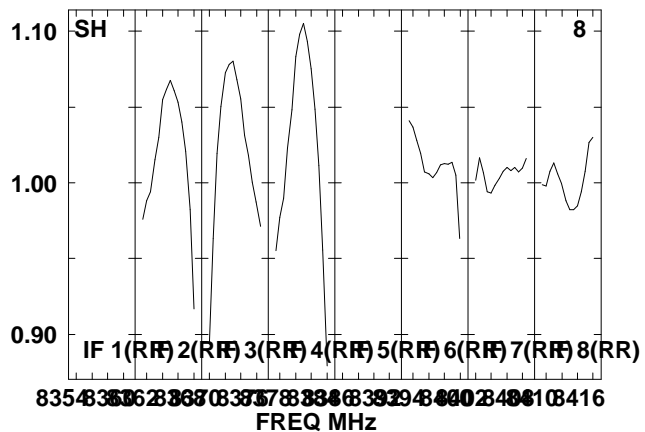
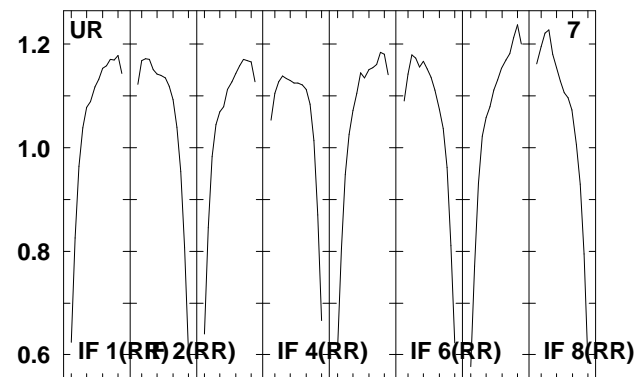
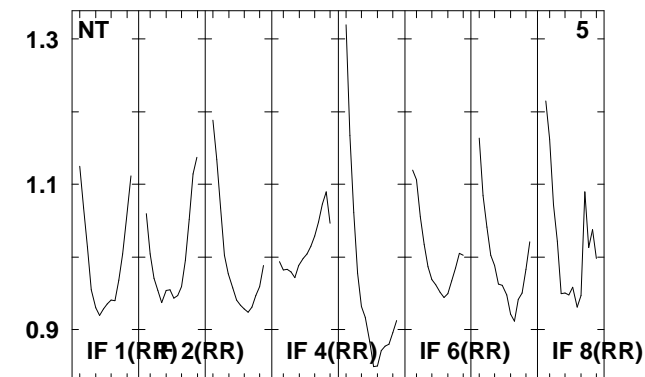
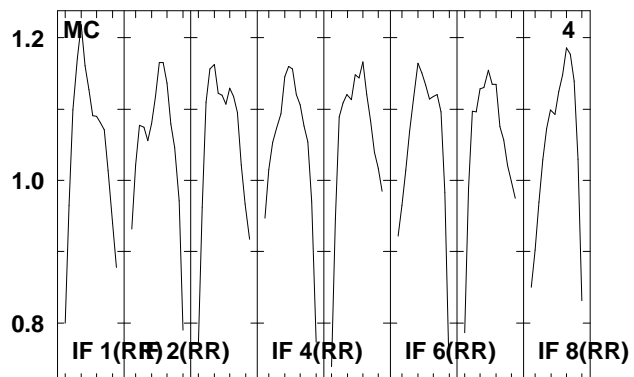
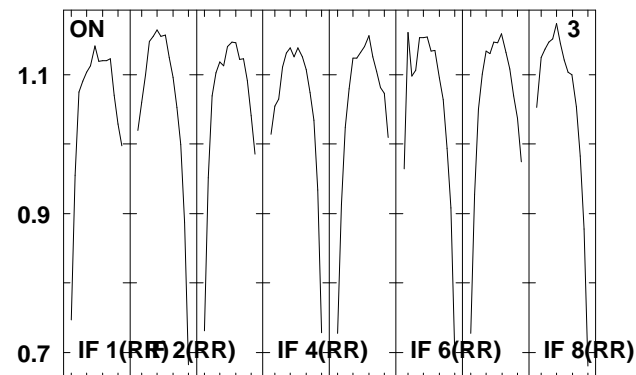
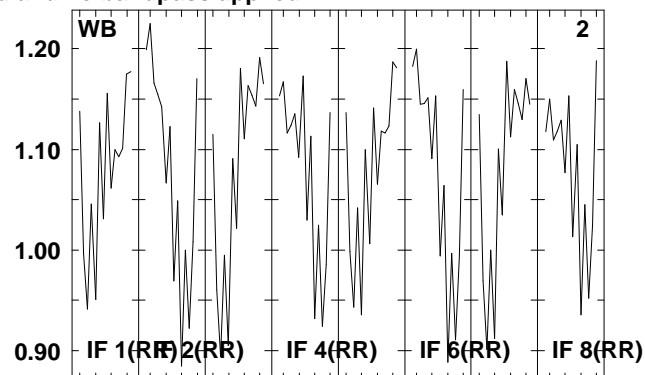
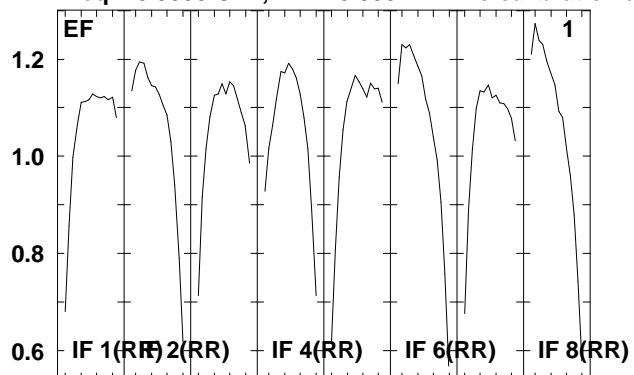

Lower frame: Real Jy

Total-power spectrum Antenna: \*

Timerange: 00/20:42:40 to 00/20:47:36

Plot file version 72 created 05-OCT-2009 09:28:27

J1651+01 EH023B 2.UVDATA.1

Freq = 8.3535 GHz, Bw = 8.000 MH No calibration applied and no bandpass applied

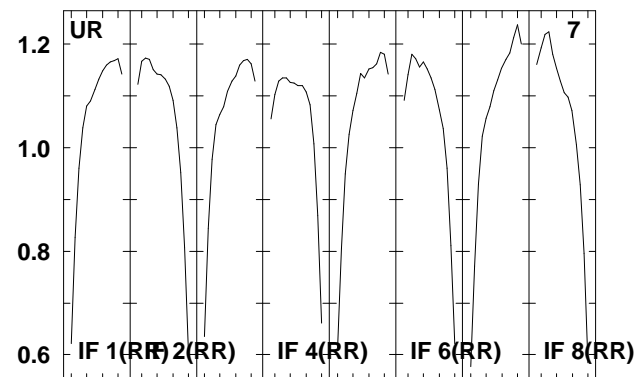
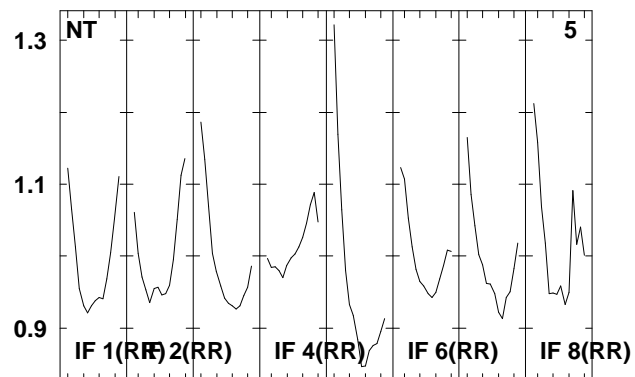
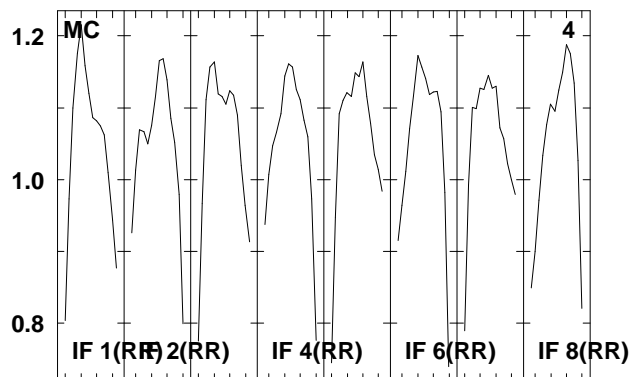
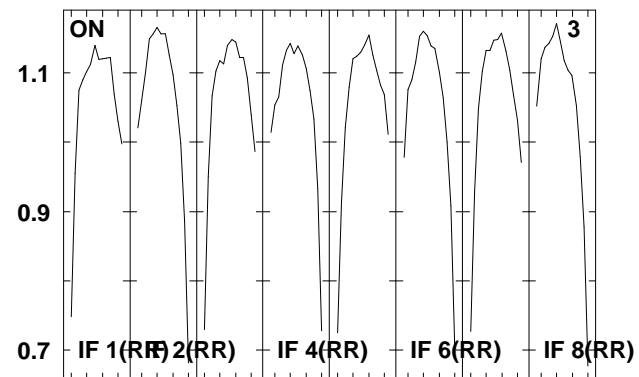
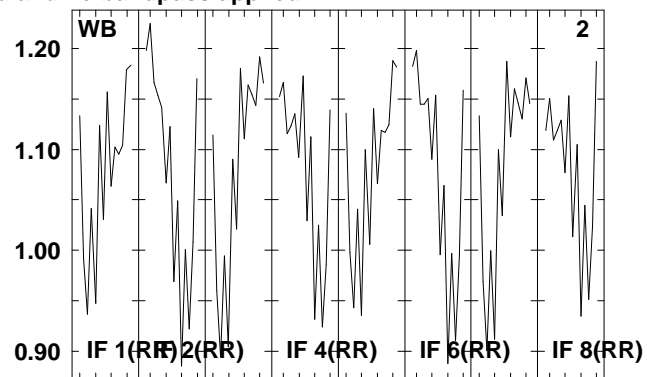
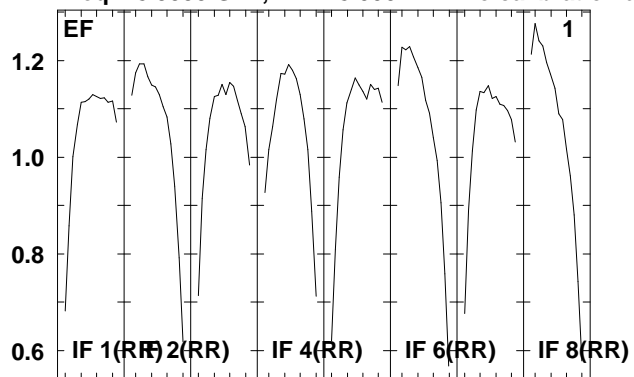

Lower frame: Real Jy  
Total-power spectrum Antenna: \*  
Timerange: 00/20:50:16 to 00/20:51:44



Plot file version 73 created 05-OCT-2009 09:28:27

NGC6240 EH023B 2.UVDATA.1

Freq = 8.3535 GHz, Bw = 8.000 MH No calibration applied and no bandpass applied

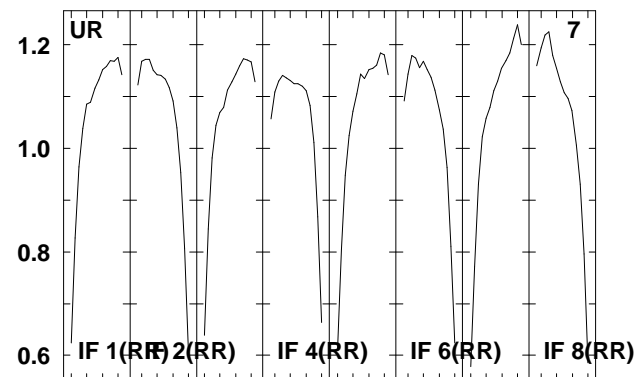
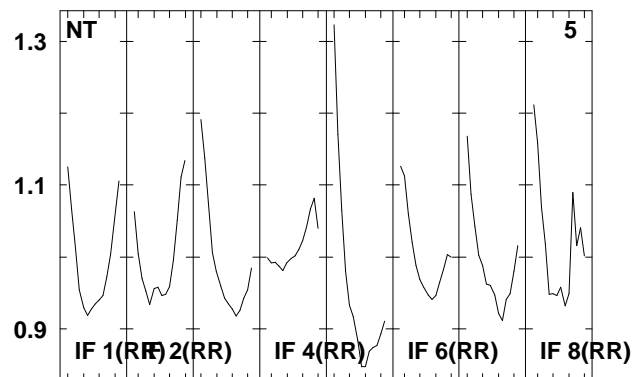
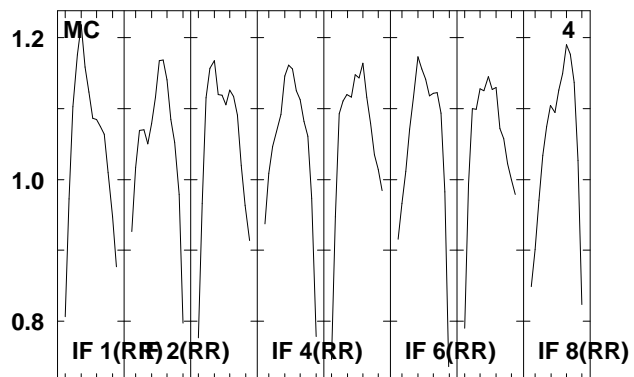
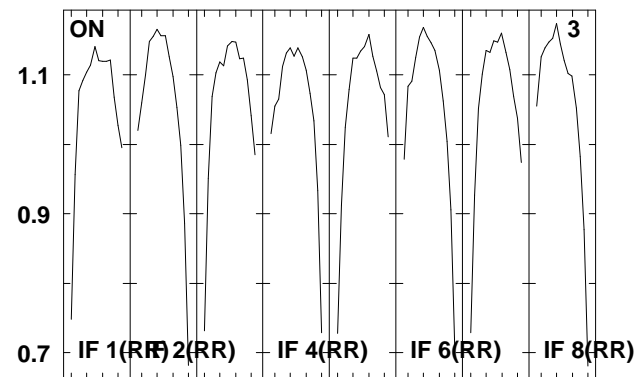
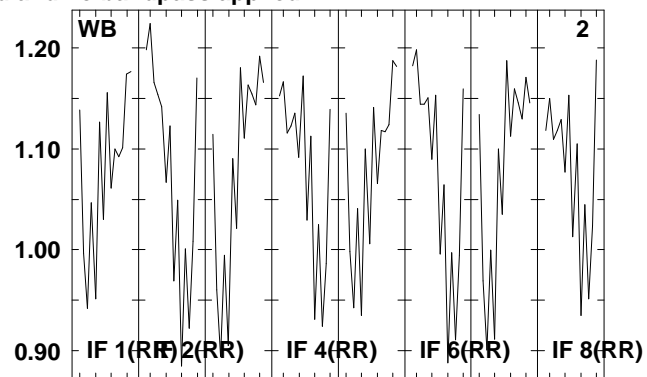
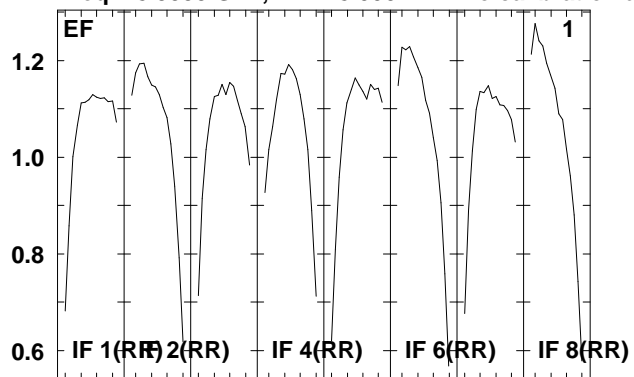

Lower frame: Real Jy  
Total-power spectrum Antenna: \*  
Timerange: 00/20:51:46 to 00/20:55:14

Plot file version 74 created 05-OCT-2009 09:28:28

J1651+01 EH023B 2.UVDATA.1

Freq = 8.3535 GHz, Bw = 8.000 MH No calibration applied and no bandpass applied

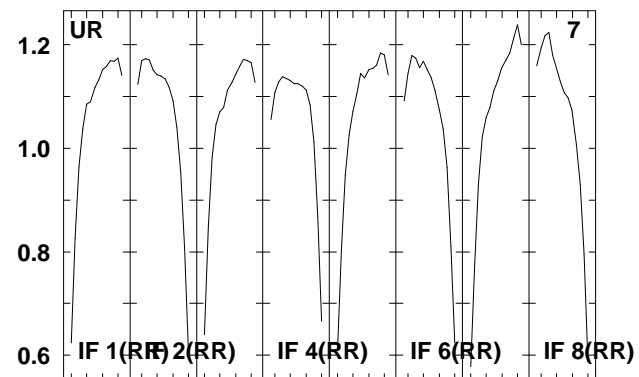
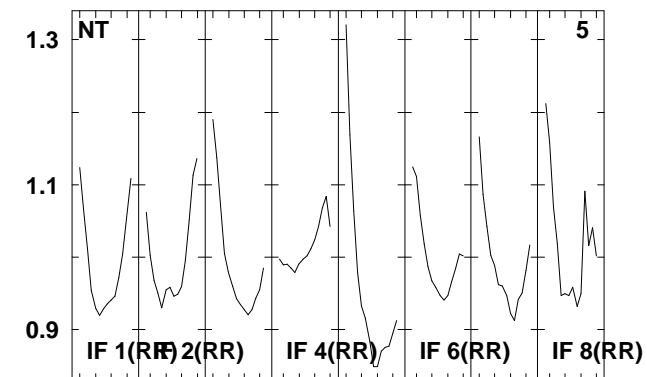
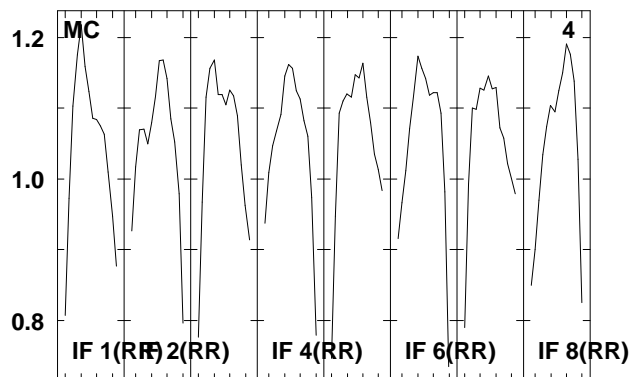
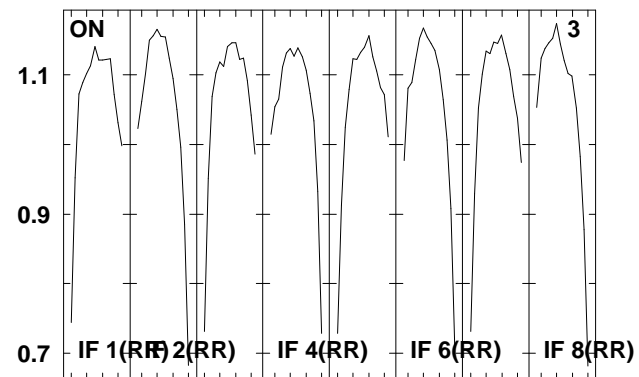
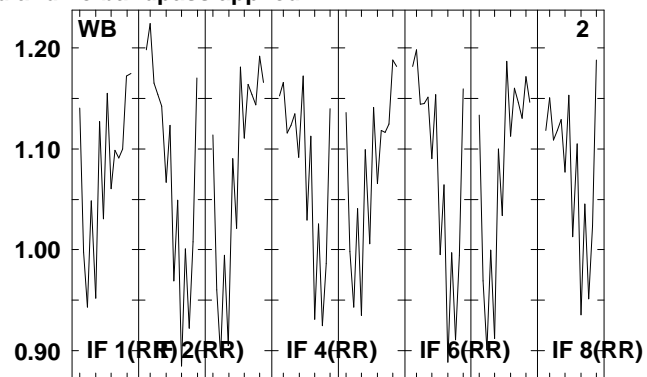
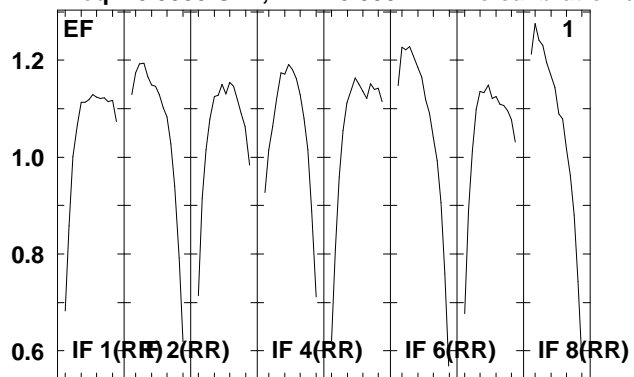

Lower frame: Real Jy  
Total-power spectrum Antenna: \*  
Timerange: 00/20:55:16 to 00/20:56:44

Plot file version 75 created 05-OCT-2009 09:28:28

NGC6240 EH023B 2.UVDATA.1

Freq = 8.3535 GHz, Bw = 8.000 MH No calibration applied and no bandpass applied

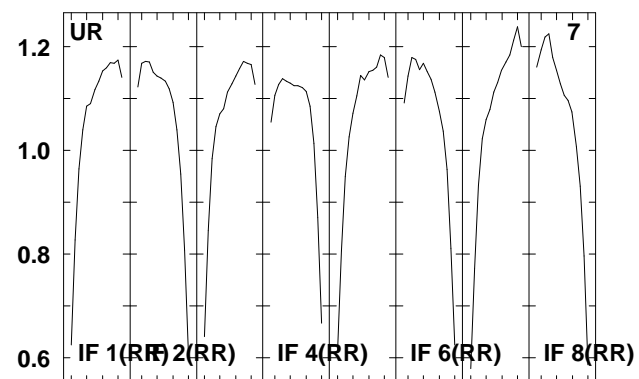
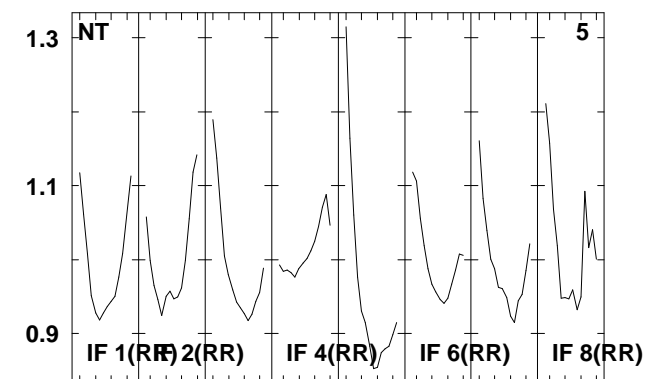
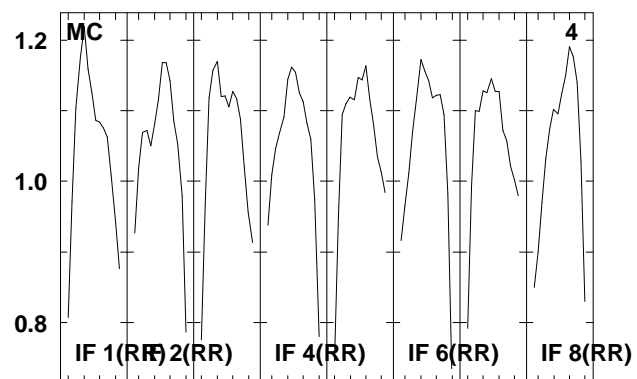
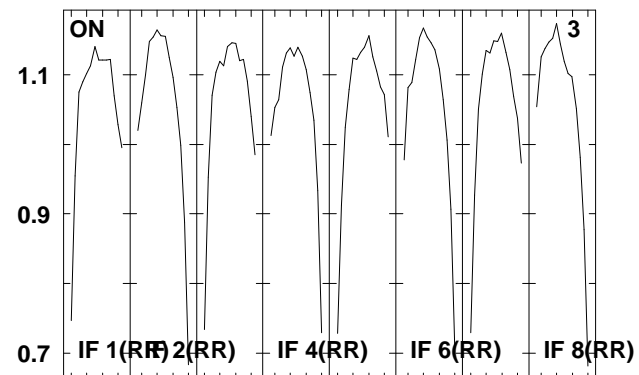
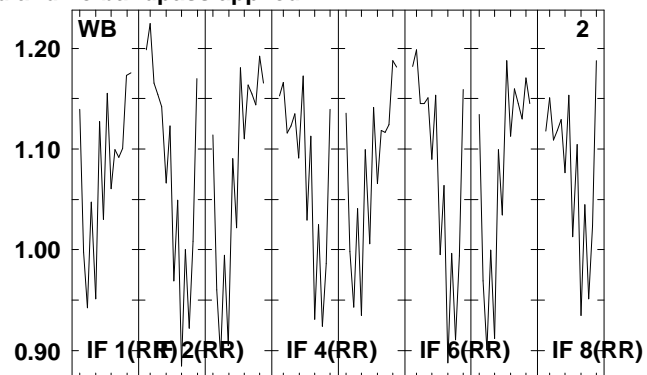
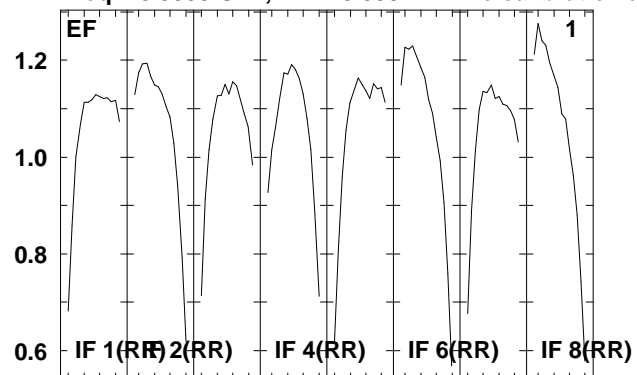

Lower frame: Real Jy  
Total-power spectrum Antenna: \*  
Timerange: 00/20:56:46 to 00/21:00:14

Plot file version 76 created 05-OCT-2009 09:28:28

J1651+01 EH023B 2.UVDATA.1

Freq = 8.3535 GHz, Bw = 8.000 MH No calibration applied and no bandpass applied

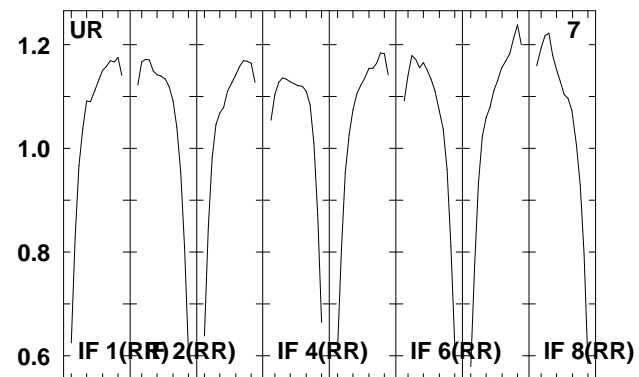
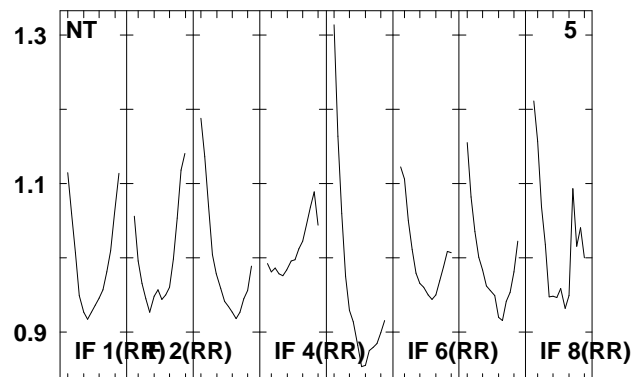
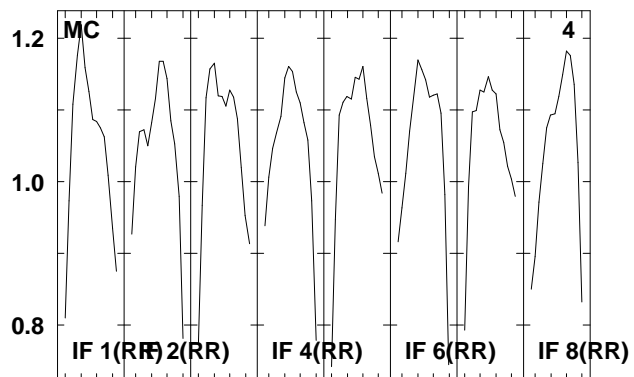
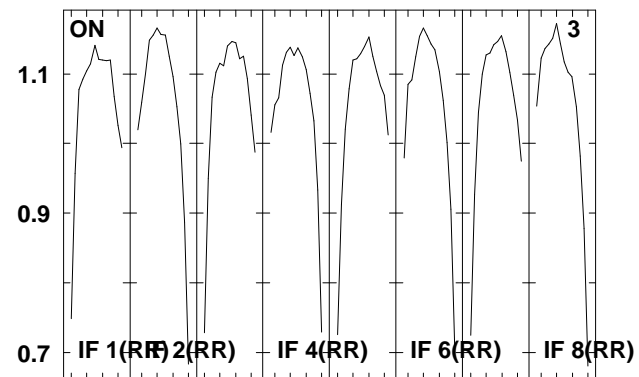
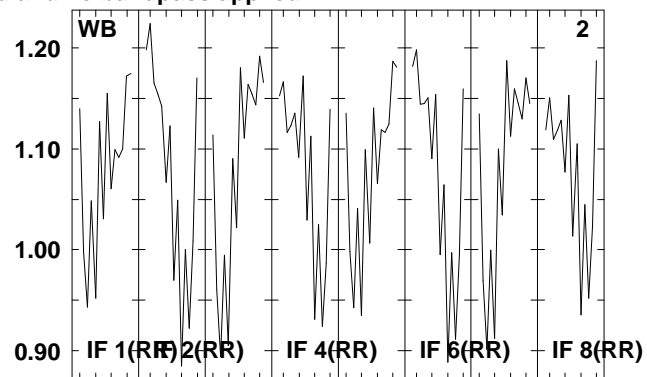
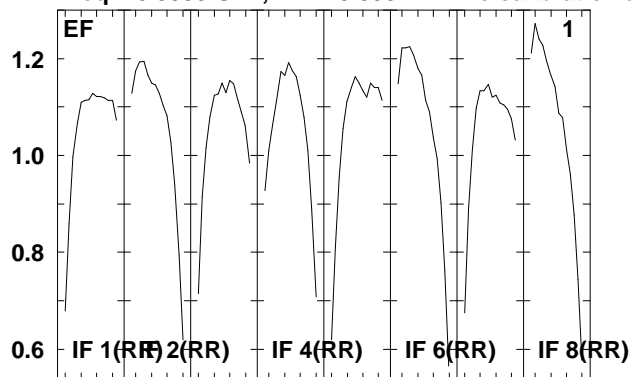

Lower frame: Real Jy  
Total-power spectrum Antenna: \*  
Timerange: 00/21:00:46 to 00/21:02:14

Plot file version 77 created 05-OCT-2009 09:28:28

NGC6240 EH023B 2.UVDATA.1

Freq = 8.3535 GHz, Bw = 8.000 MH No calibration applied and no bandpass applied

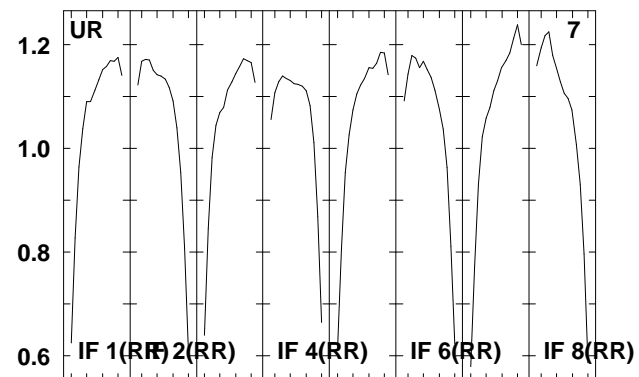
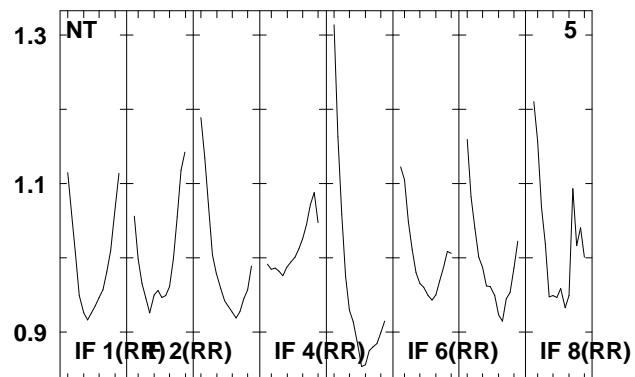
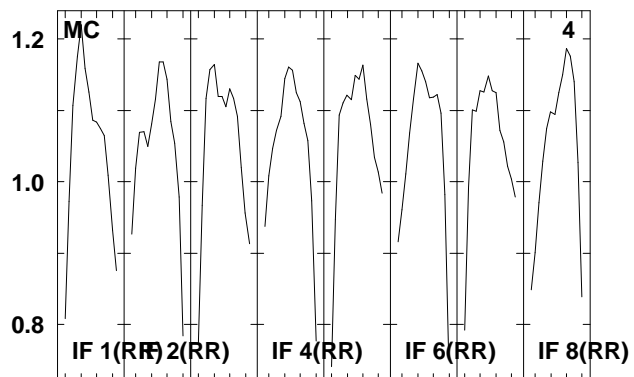
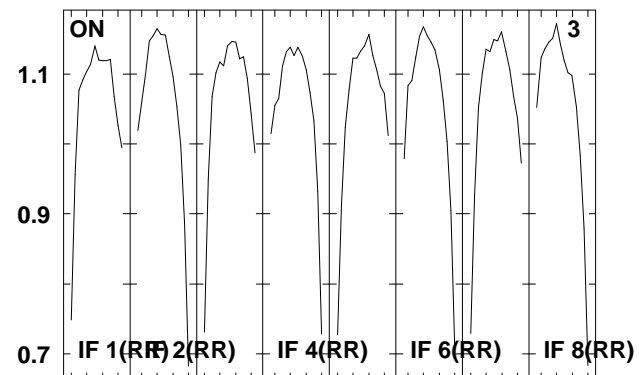
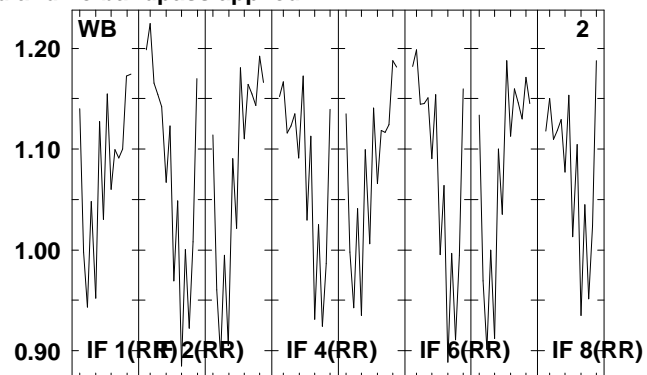
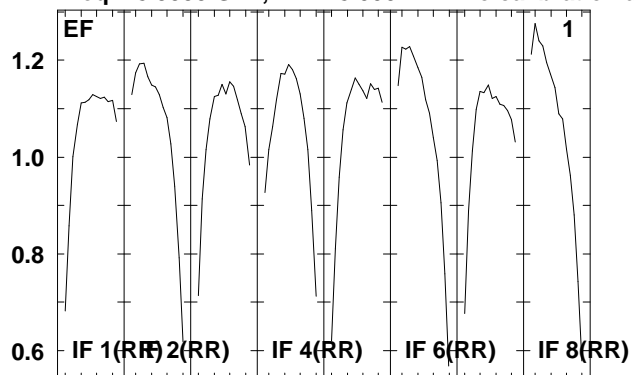

Lower frame: Real Jy  
Total-power spectrum Antenna: \*  
Timerange: 00/21:02:16 to 00/21:05:44

Plot file version 78 created 05-OCT-2009 09:28:28

J1651+01 EH023B 2.UVDATA.1

Freq = 8.3535 GHz, Bw = 8.000 MH No calibration applied and no bandpass applied

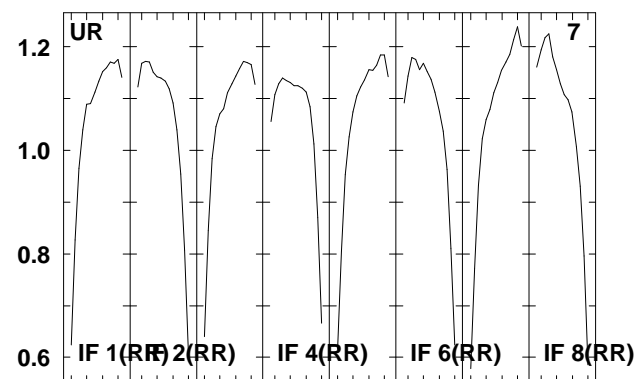
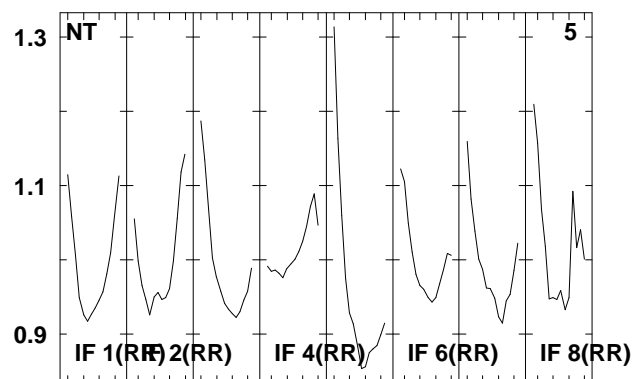
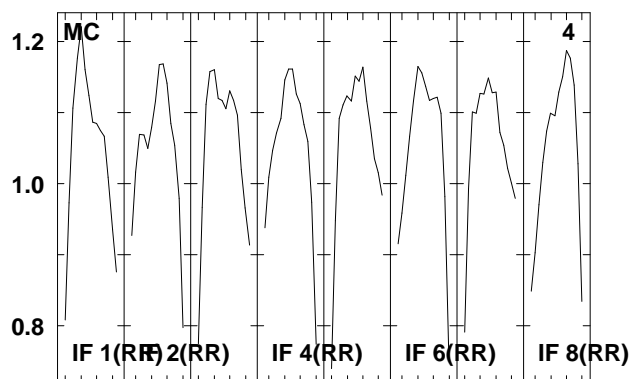
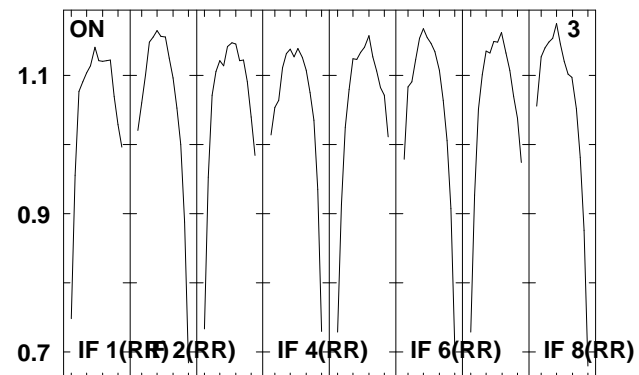
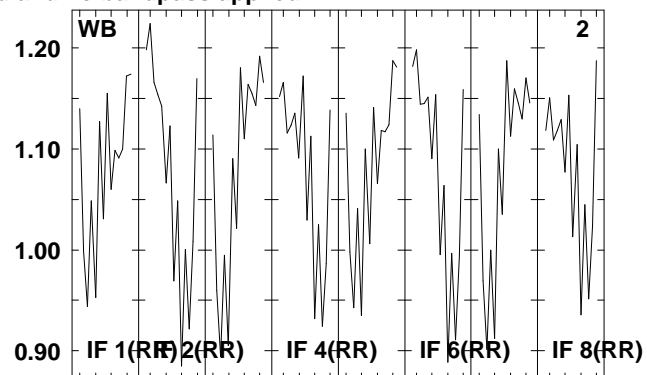
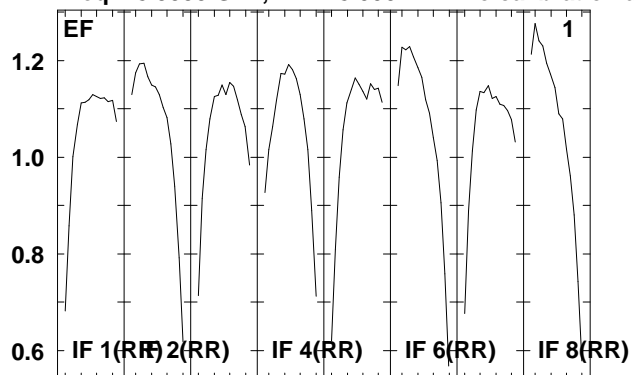

Lower frame: Real Jy  
Total-power spectrum Antenna: \*  
Timerange: 00/21:05:46 to 00/21:07:14

Plot file version 79 created 05-OCT-2009 09:28:28

NGC6240 EH023B 2.UVDATA.1

Freq = 8.3535 GHz, Bw = 8.000 MH No calibration applied and no bandpass applied

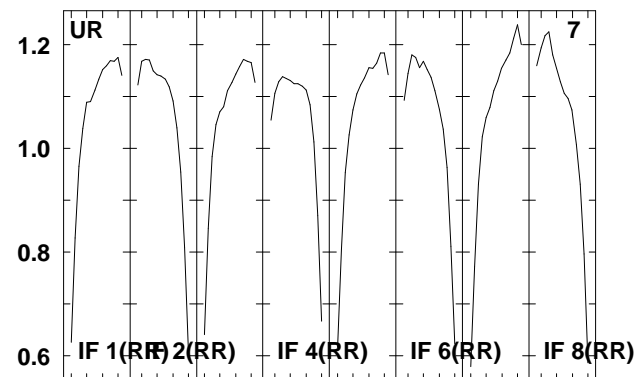
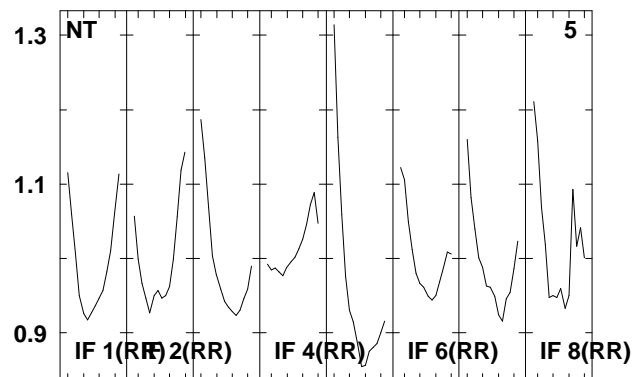
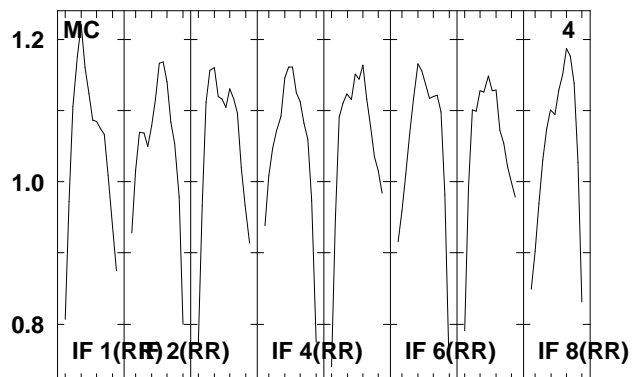
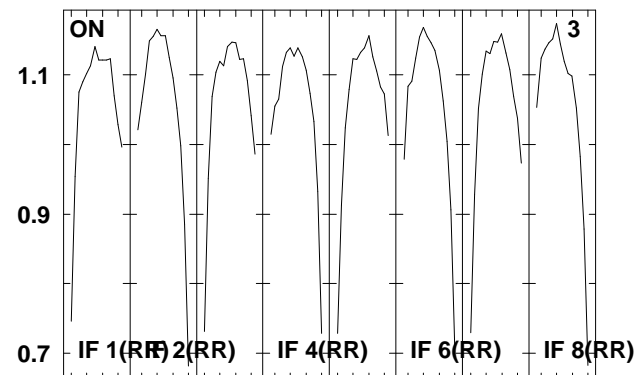
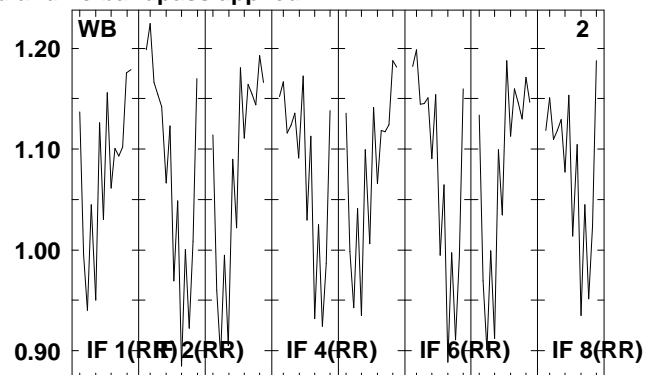
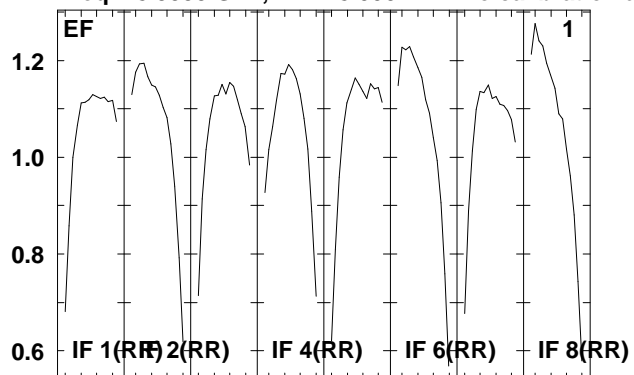

Lower frame: Real Jy  
Total-power spectrum Antenna: \*  
Timerange: 00/21:07:16 to 00/21:10:44

Plot file version 80 created 05-OCT-2009 09:28:29

J1651+01 EH023B 2.UVDATA.1

Freq = 8.3535 GHz, Bw = 8.000 MH No calibration applied and no bandpass applied

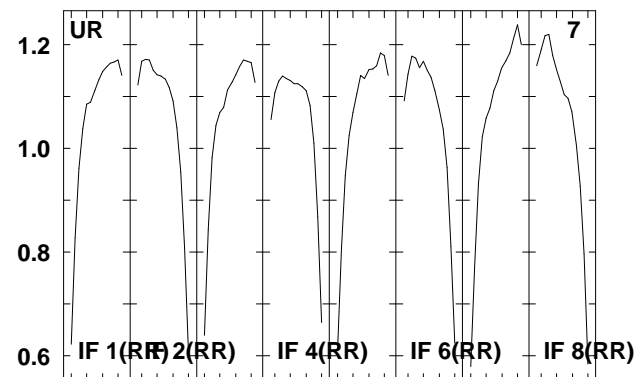
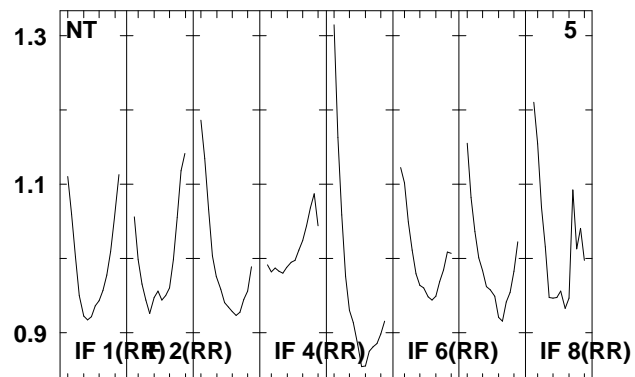
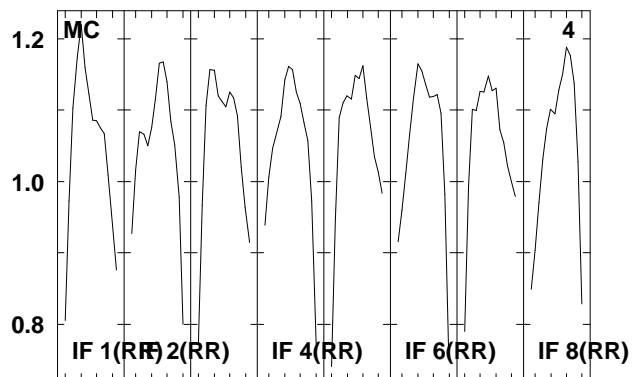
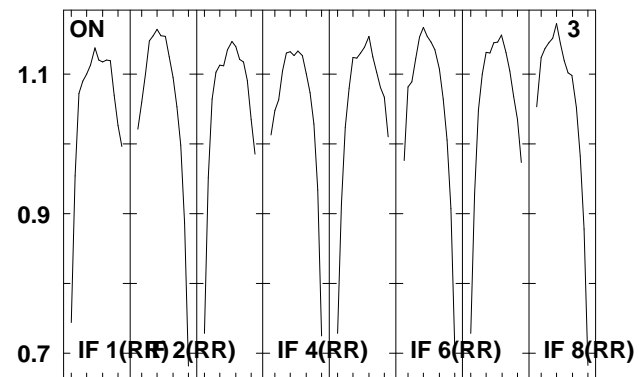
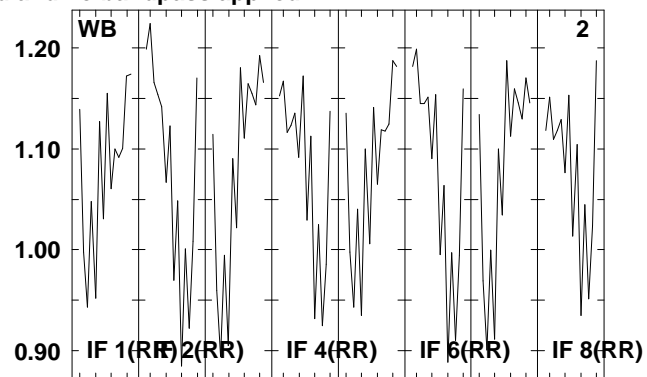
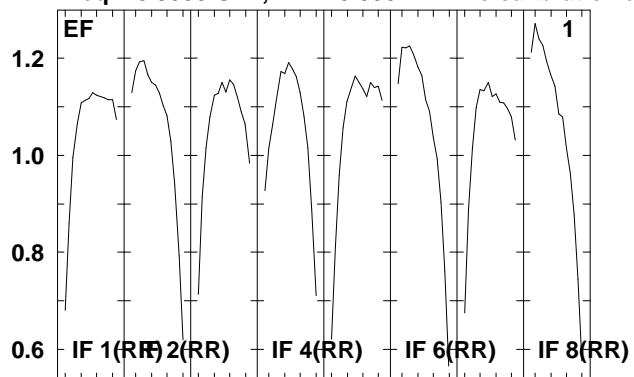

Lower frame: Real Jy  
Total-power spectrum Antenna: \*  
Timerange: 00/21:11:16 to 00/21:12:44



Plot file version 81 created 05-OCT-2009 09:28:29

NGC6240 EH023B 2.UVDATA.1

Freq = 8.3535 GHz, Bw = 8.000 MH No calibration applied and no bandpass applied

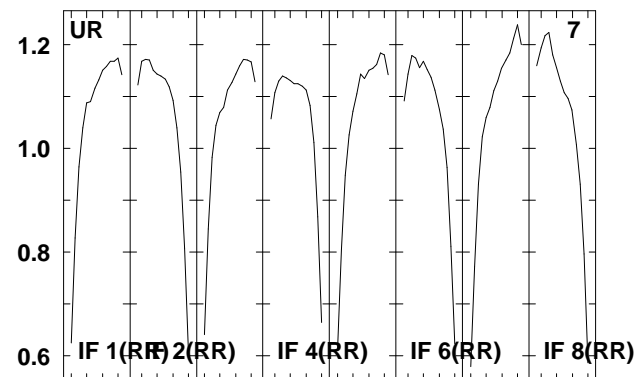
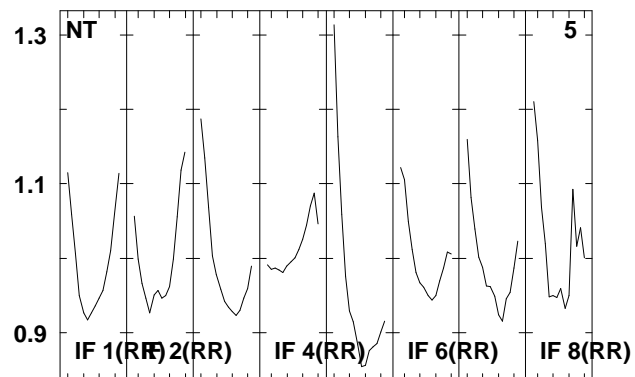
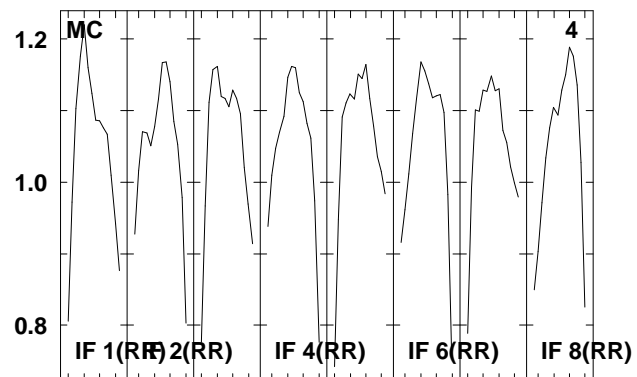
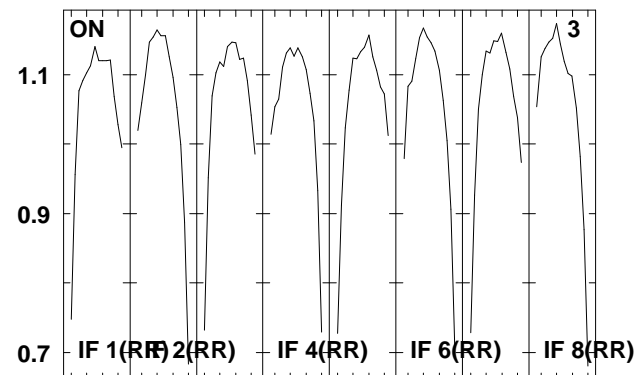
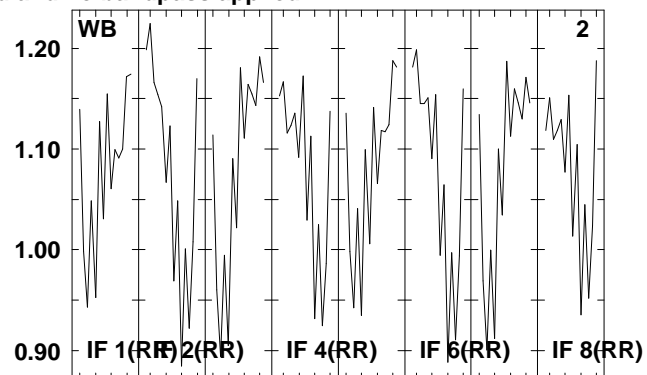
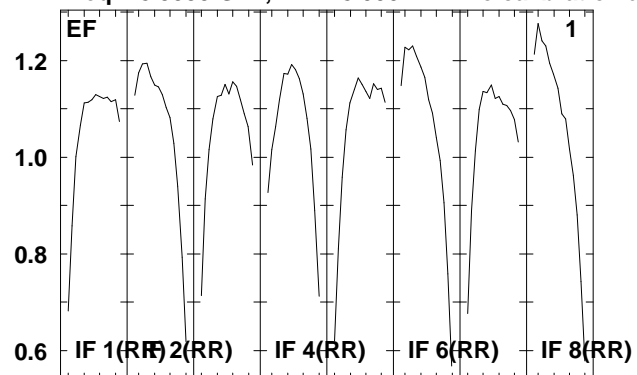

Lower frame: Real Jy  
Total-power spectrum Antenna: \*  
Timerange: 00/21:12:46 to 00/21:16:14

Plot file version 82 created 05-OCT-2009 09:28:29

J1651+01 EH023B 2.UVDATA.1

Freq = 8.3535 GHz, Bw = 8.000 MH No calibration applied and no bandpass applied

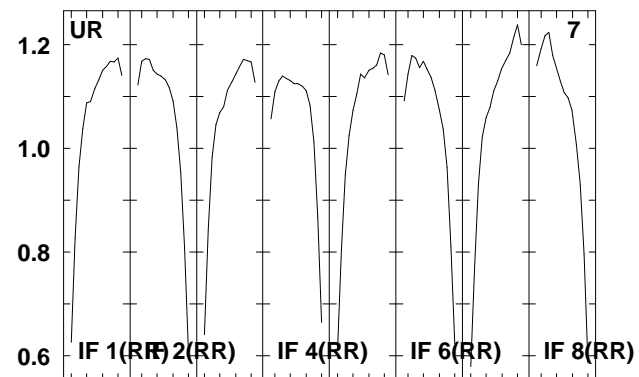
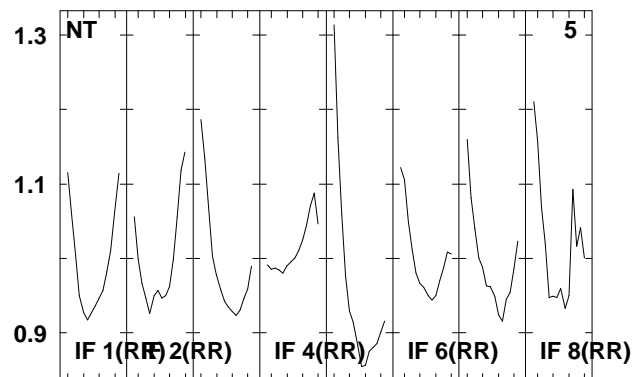
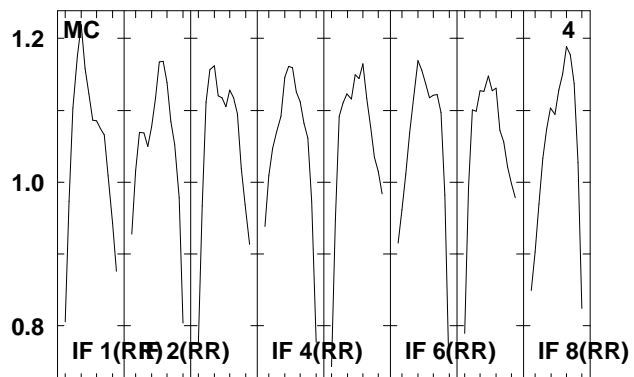
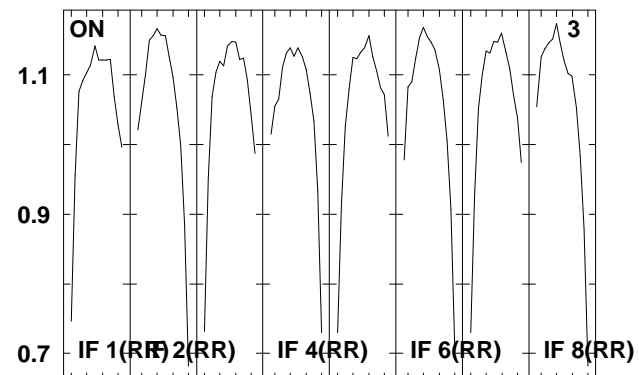
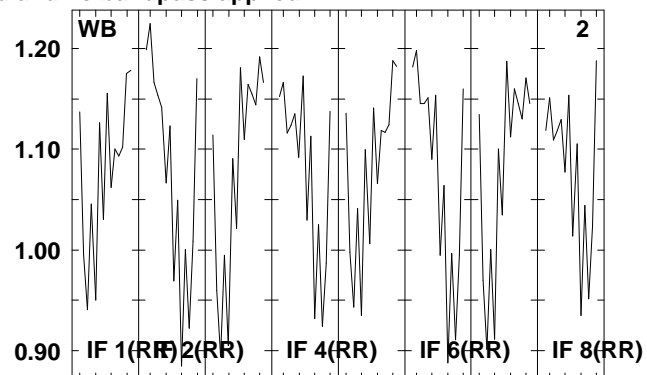
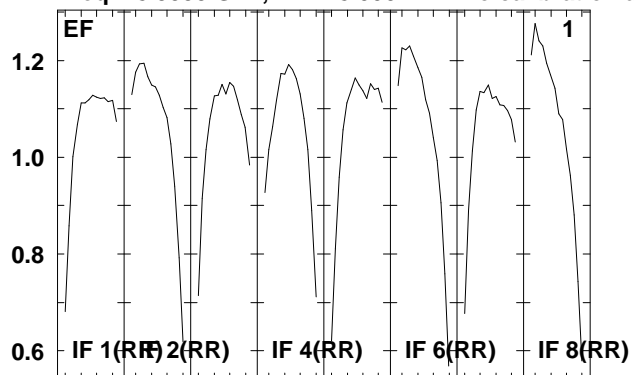

Lower frame: Real Jy  
Total-power spectrum Antenna: \*  
Timerange: 00/21:16:16 to 00/21:17:44

Plot file version 83 created 05-OCT-2009 09:28:29

NGC6240 EH023B 2.UVDATA.1

Freq = 8.3535 GHz, Bw = 8.000 MH No calibration applied and no bandpass applied

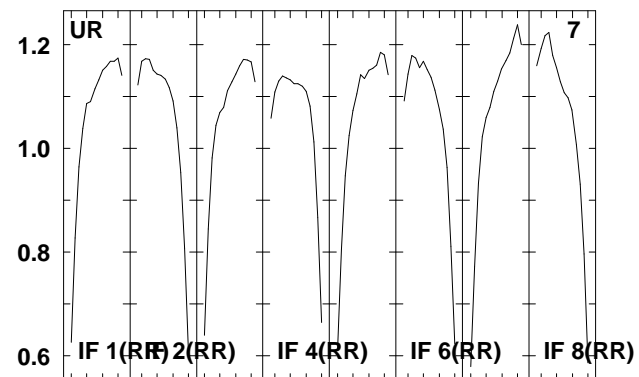
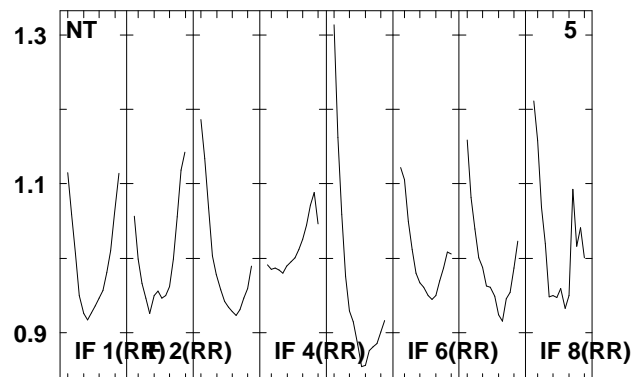
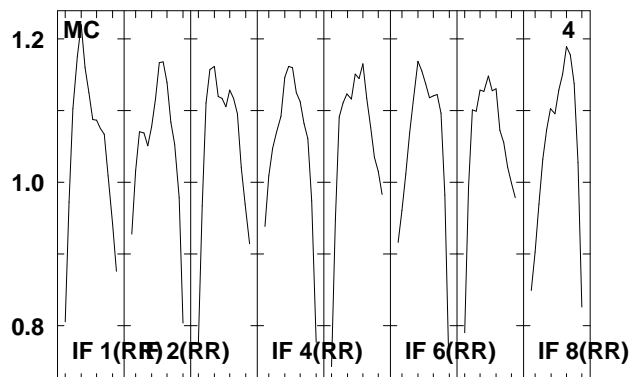
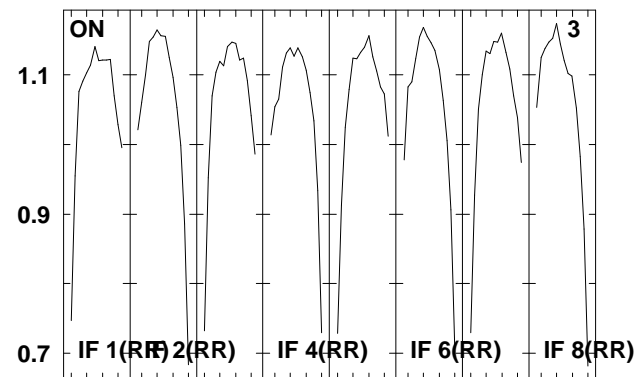
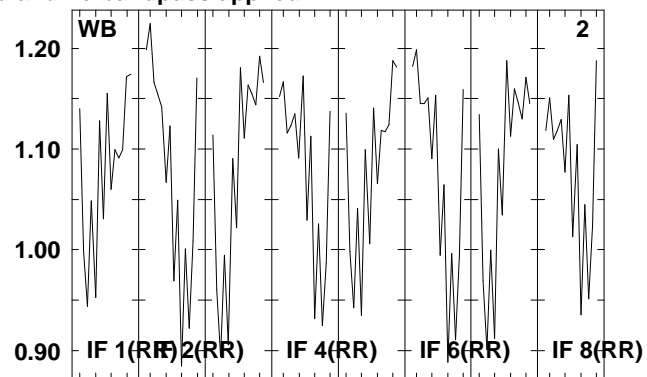
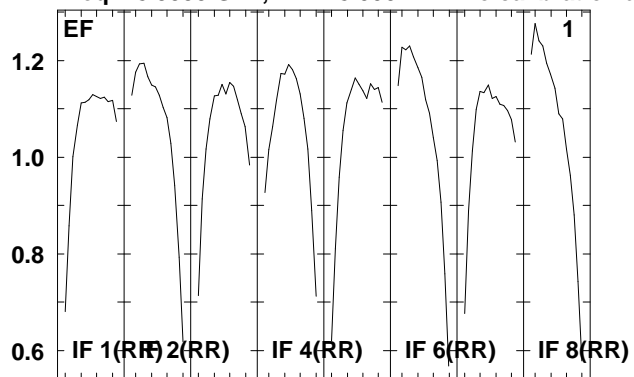

Lower frame: Real Jy  
Total-power spectrum Antenna: \*  
Timerange: 00/21:17:46 to 00/21:21:14

Plot file version 84 created 05-OCT-2009 09:28:30

J1651+01 EH023B 2.UVDATA.1

Freq = 8.3535 GHz, Bw = 8.000 MH No calibration applied and no bandpass applied

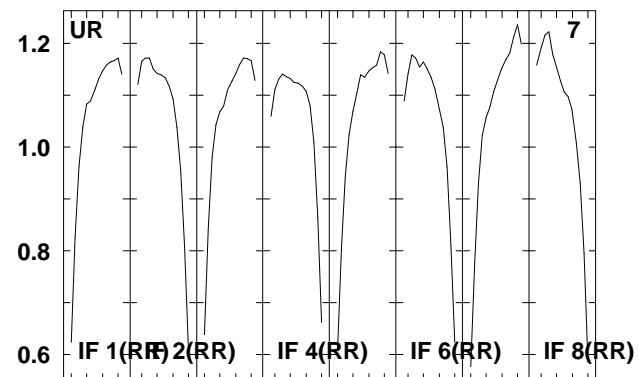
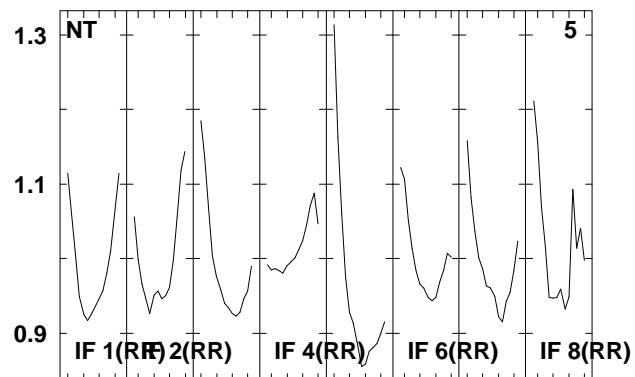
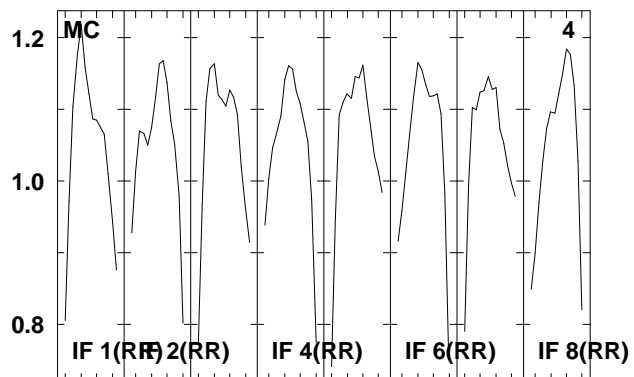
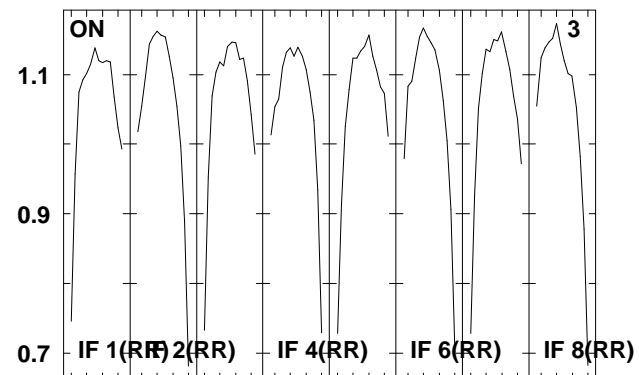
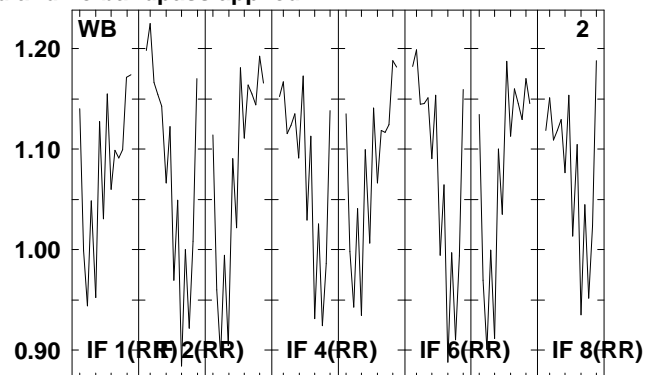
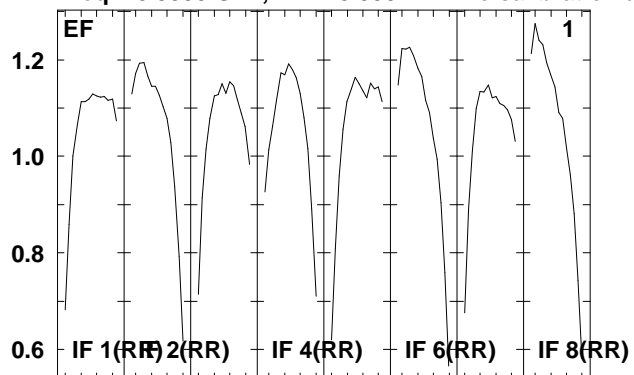

Lower frame: Real Jy  
Total-power spectrum Antenna: \*  
Timerange: 00/21:21:46 to 00/21:23:14

Plot file version 85 created 05-OCT-2009 09:28:30

NGC6240 EH023B 2.UVDATA.1

Freq = 8.3535 GHz, Bw = 8.000 MH No calibration applied and no bandpass applied

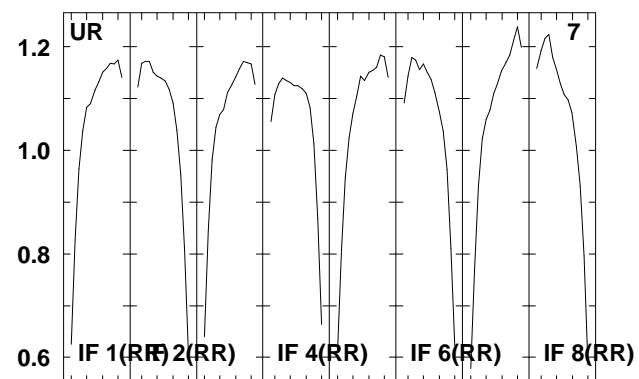
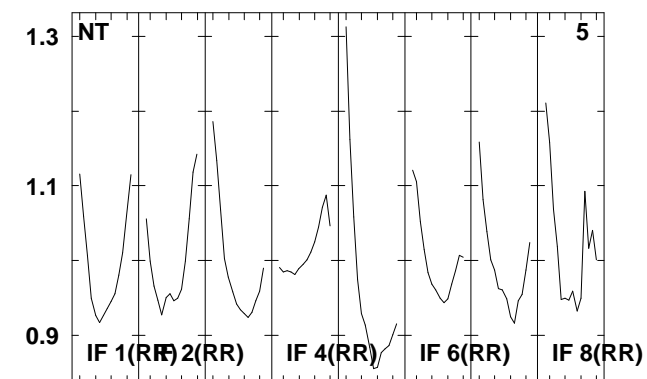
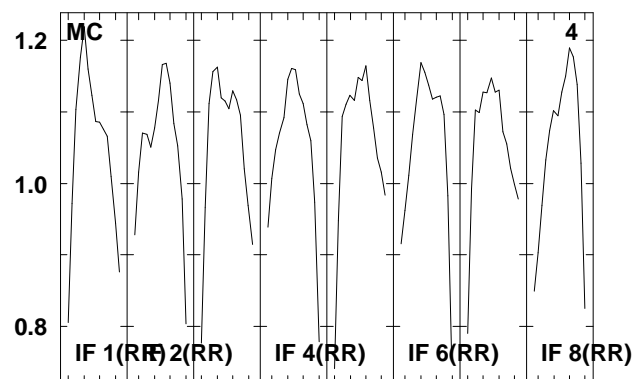
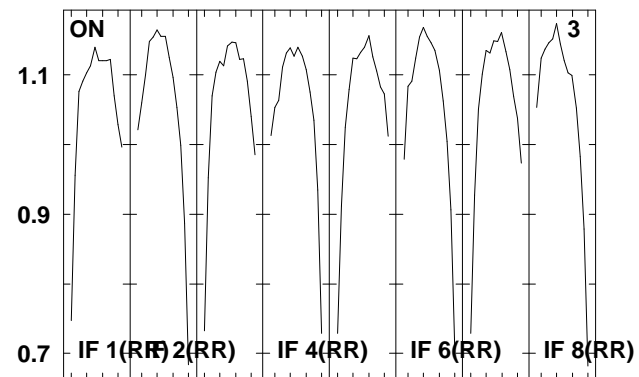
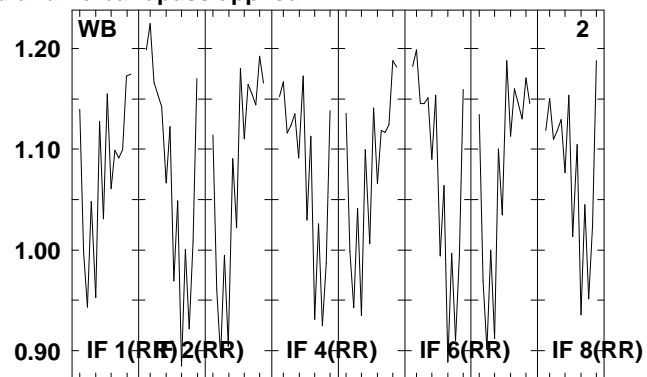
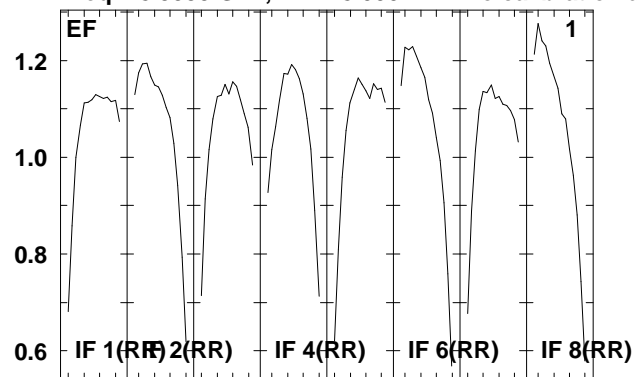

Lower frame: Real Jy  
Total-power spectrum Antenna: \*  
Timerange: 00/21:23:16 to 00/21:26:44

Plot file version 86 created 05-OCT-2009 09:28:30

J1651+01 EH023B 2.UVDATA.1

Freq = 8.3535 GHz, Bw = 8.000 MH No calibration applied and no bandpass applied

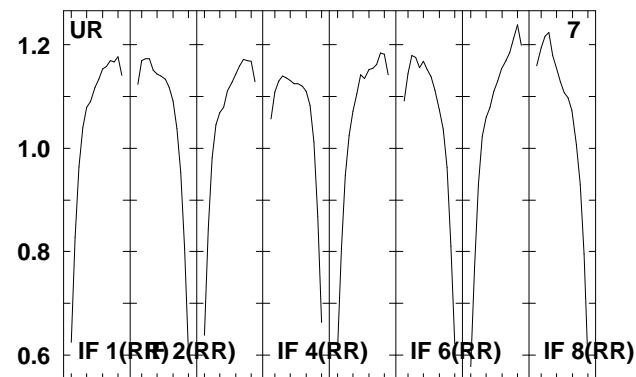
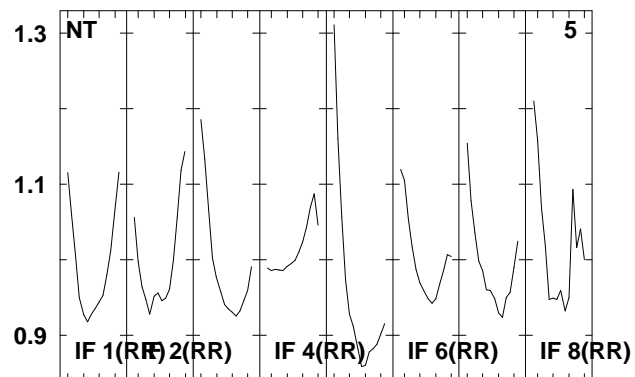
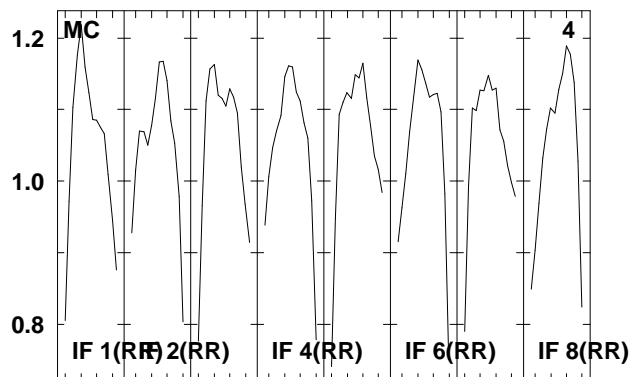
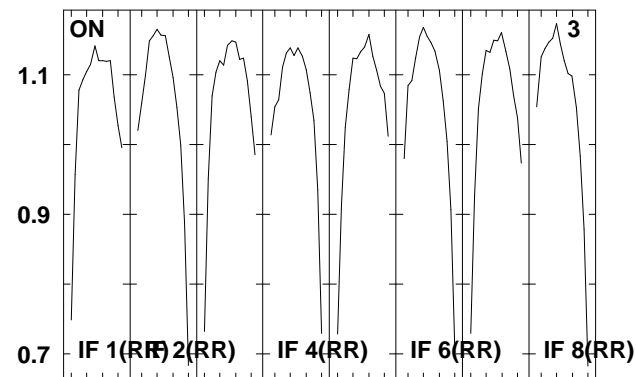
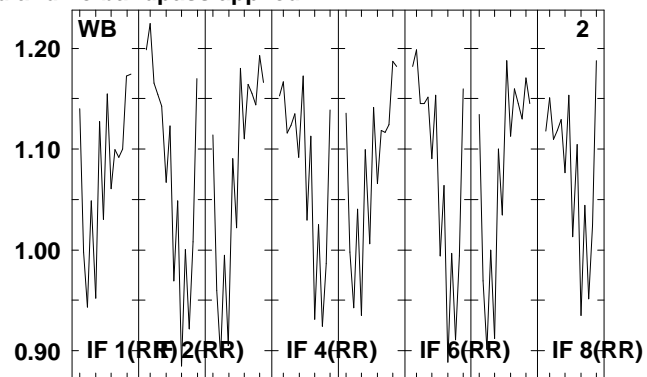
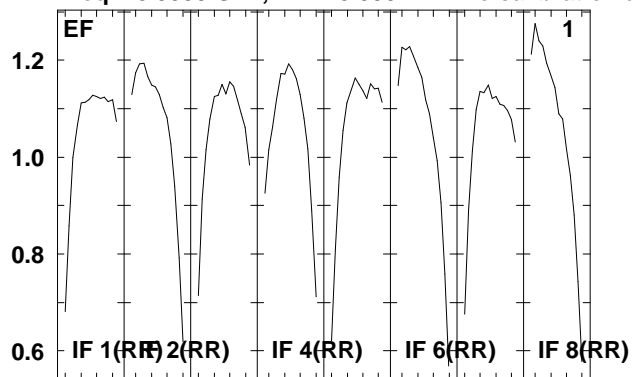

Lower frame: Real Jy  
Total-power spectrum Antenna: \*  
Timerange: 00/21:26:46 to 00/21:28:14

Plot file version 87 created 05-OCT-2009 09:28:30

NGC6240 EH023B 2.UVDATA.1

Freq = 8.3535 GHz, Bw = 8.000 MH No calibration applied and no bandpass applied

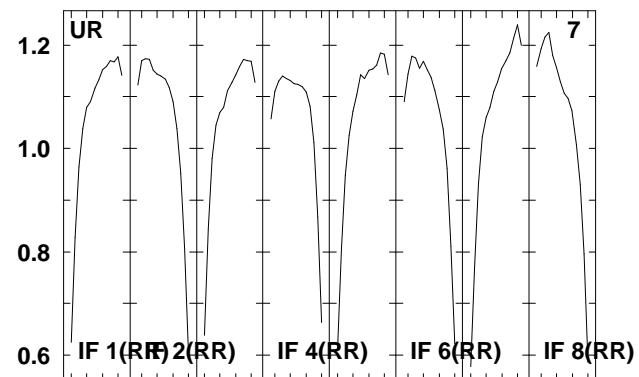
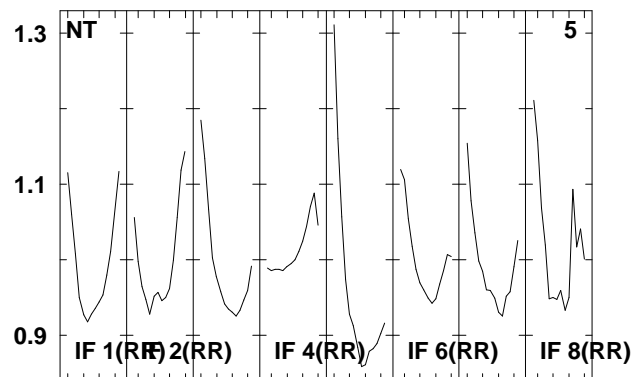
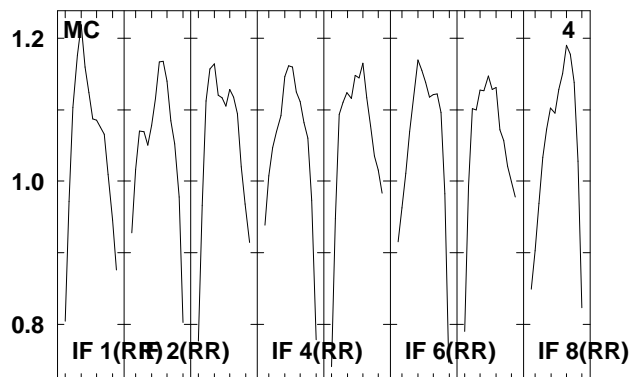
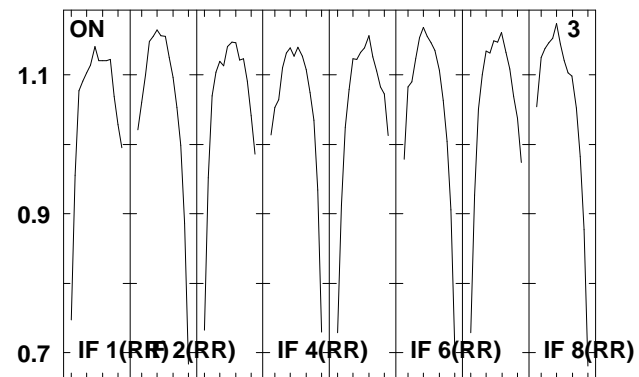
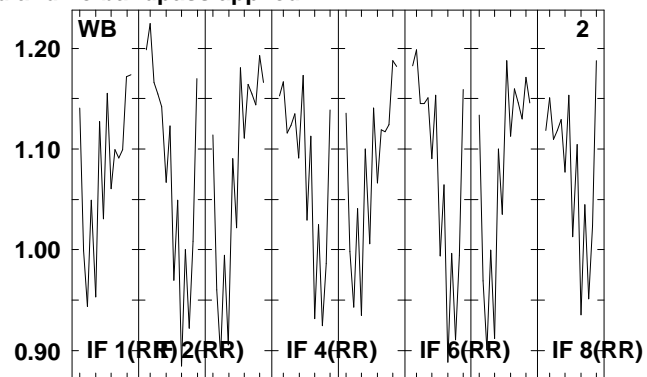
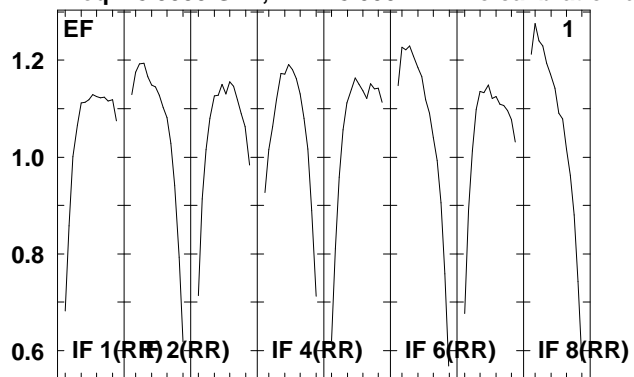

Lower frame: Real Jy  
Total-power spectrum Antenna: \*  
Timerange: 00/21:28:16 to 00/21:31:44

Plot file version 88 created 05-OCT-2009 09:28:30

J1651+01 EH023B 2.UVDATA.1

Freq = 8.3535 GHz, Bw = 8.000 MH No calibration applied and no bandpass applied

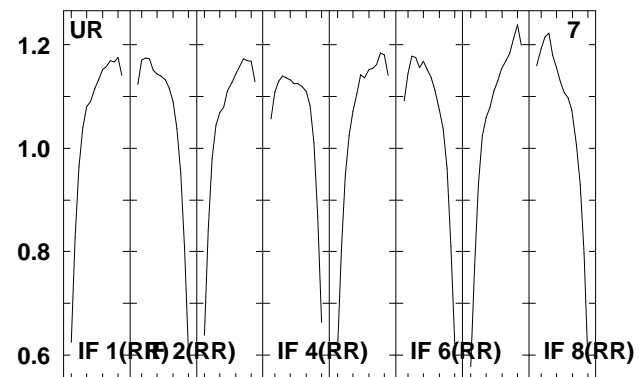
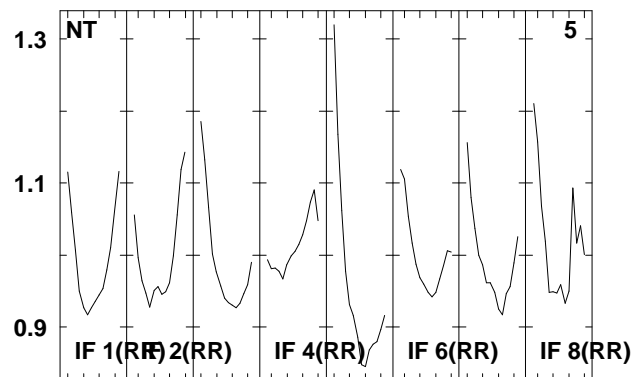
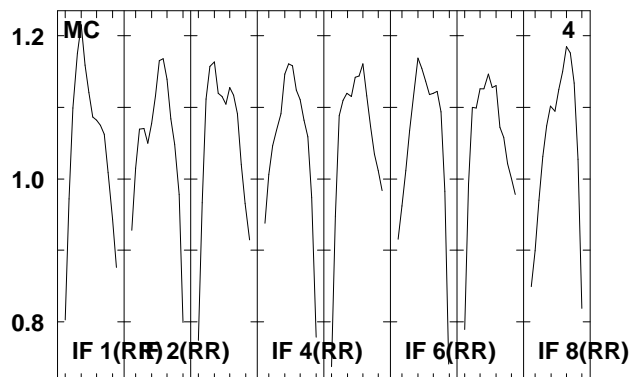
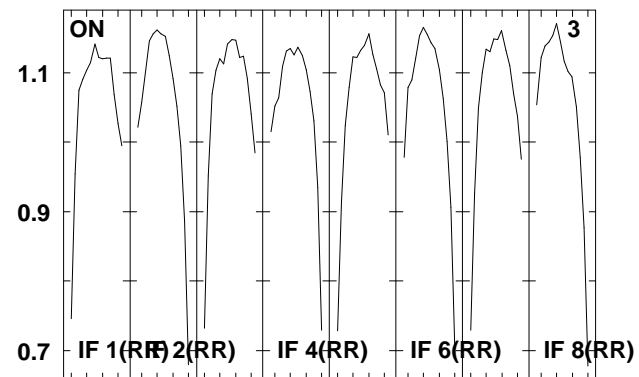
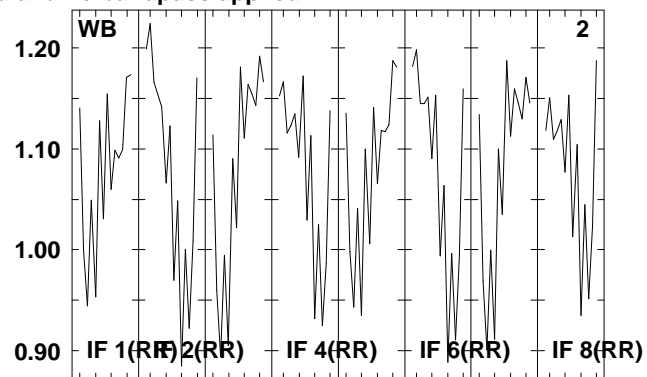
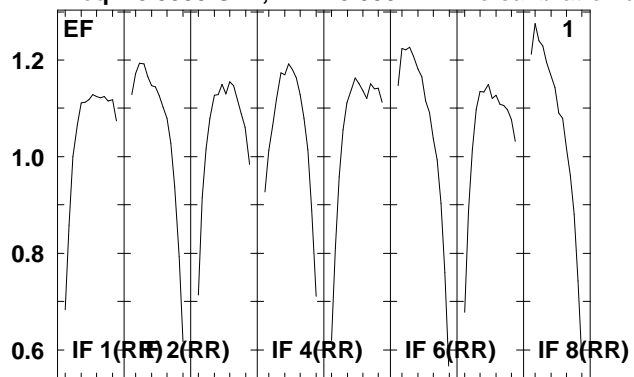

Lower frame: Real Jy  
Total-power spectrum Antenna: \*  
Timerange: 00/21:32:16 to 00/21:33:44



Plot file version 89 created 05-OCT-2009 09:28:30

NGC6240 EH023B 2.UVDATA.1

Freq = 8.3535 GHz, Bw = 8.000 MH No calibration applied and no bandpass applied

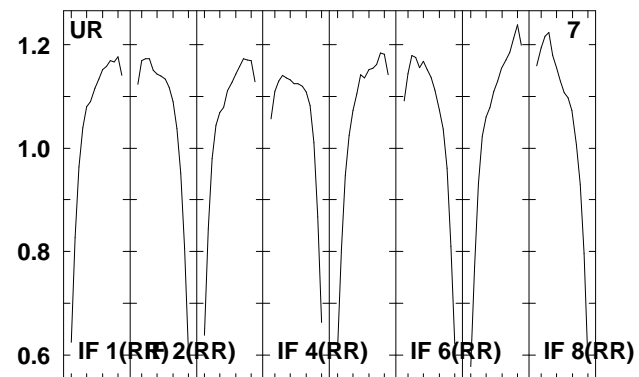
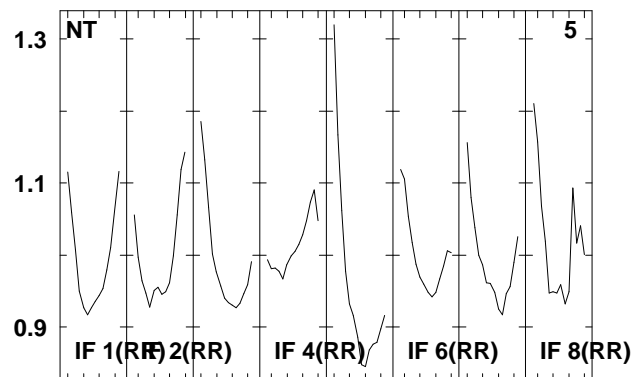
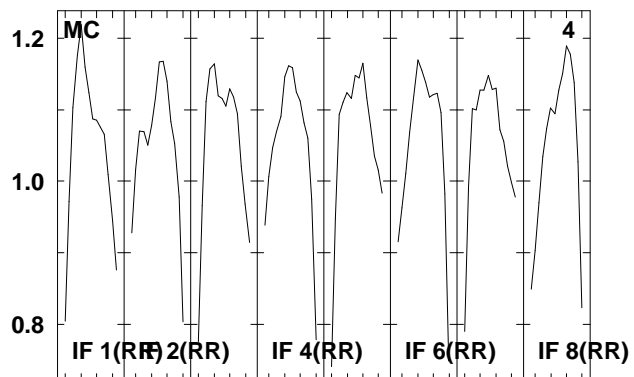
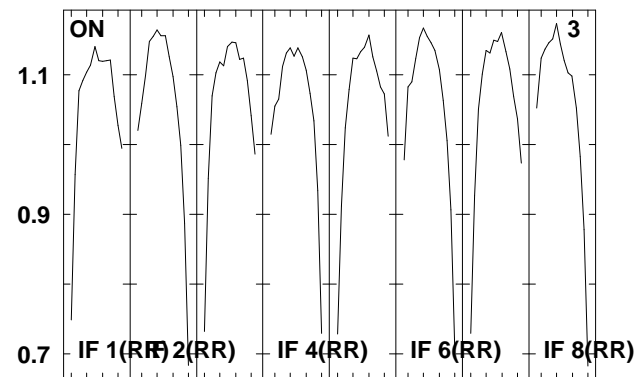
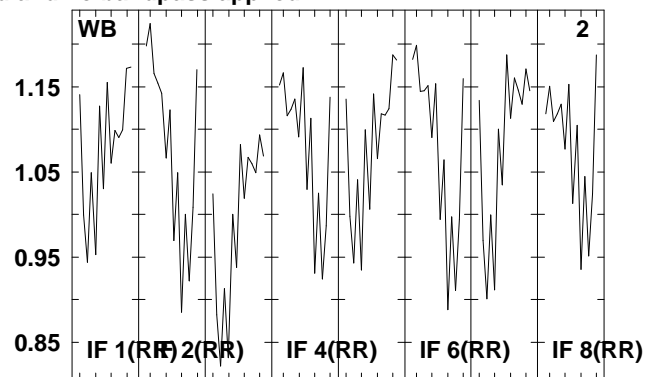
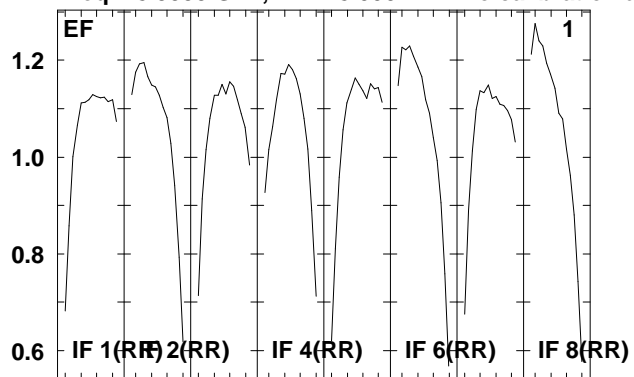

Lower frame: Real Jy  
Total-power spectrum Antenna: \*  
Timerange: 00/21:33:46 to 00/21:37:14

Plot file version 90 created 05-OCT-2009 09:28:31

J1651+01 EH023B 2.UVDATA.1

Freq = 8.3535 GHz, Bw = 8.000 MH No calibration applied and no bandpass applied

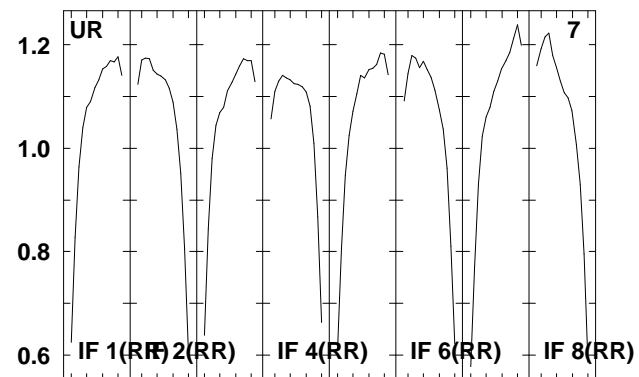
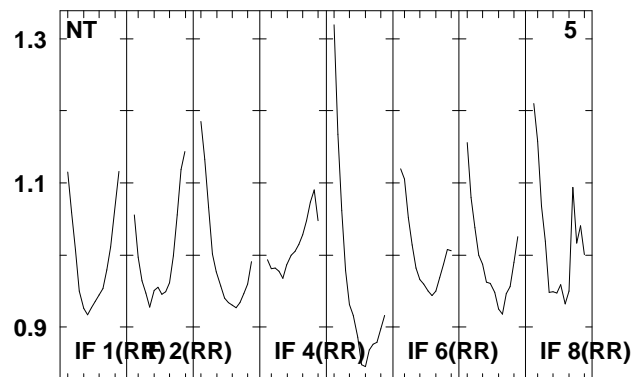
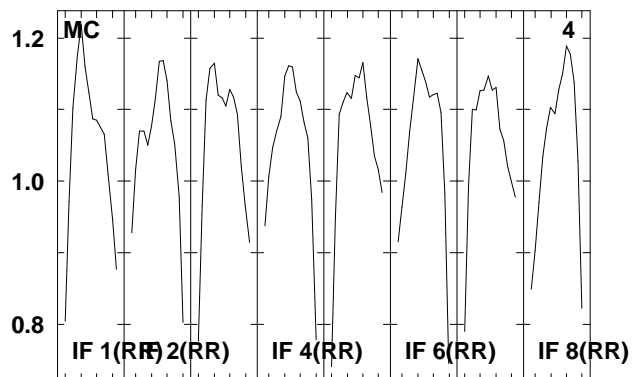
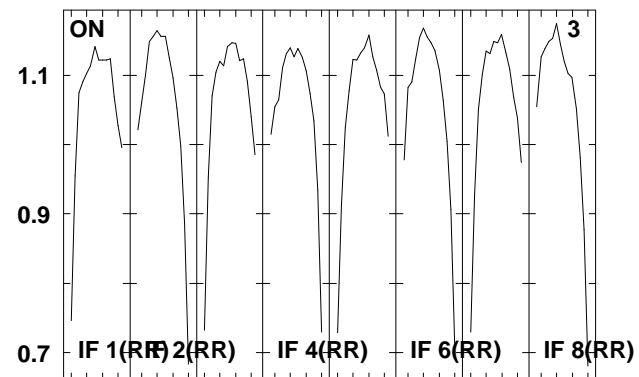
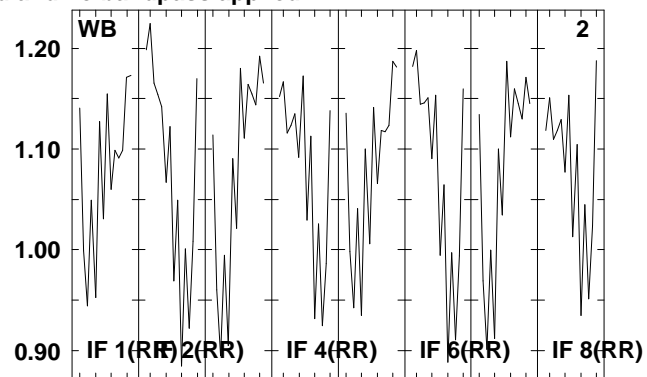
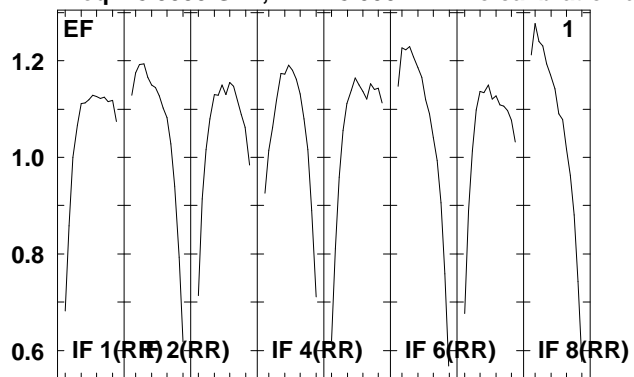

Lower frame: Real Jy  
Total-power spectrum Antenna: \*  
Timerange: 00/21:37:16 to 00/21:38:44

Plot file version 91 created 05-OCT-2009 09:28:31

NGC6240 EH023B 2.UVDATA.1

Freq = 8.3535 GHz, Bw = 8.000 MH No calibration applied and no bandpass applied

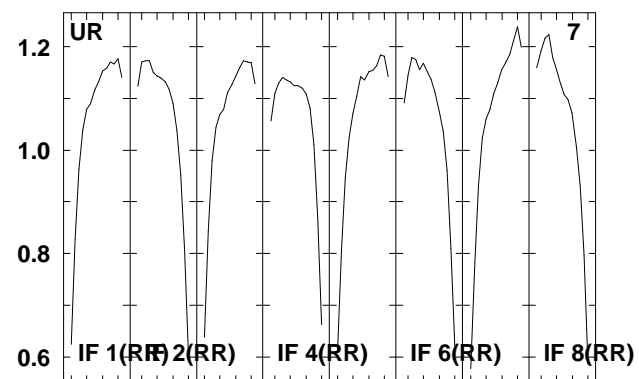
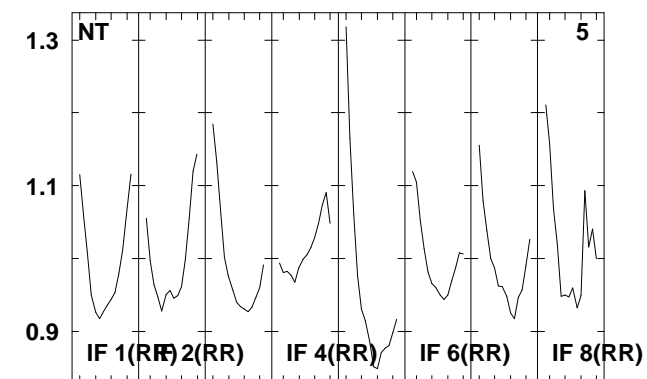
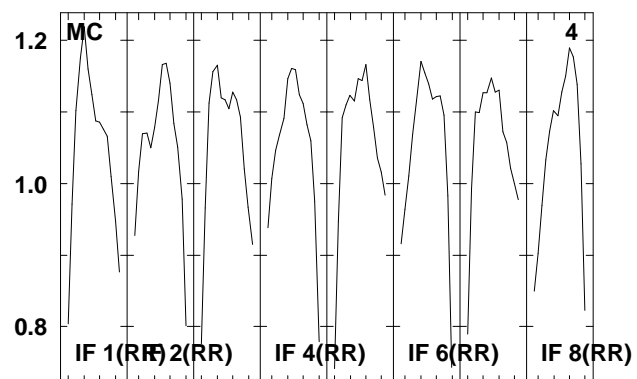
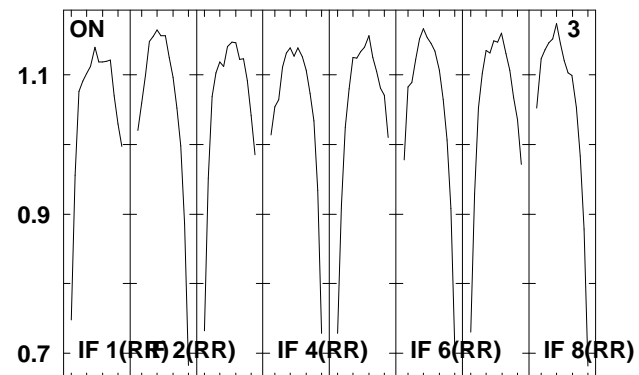
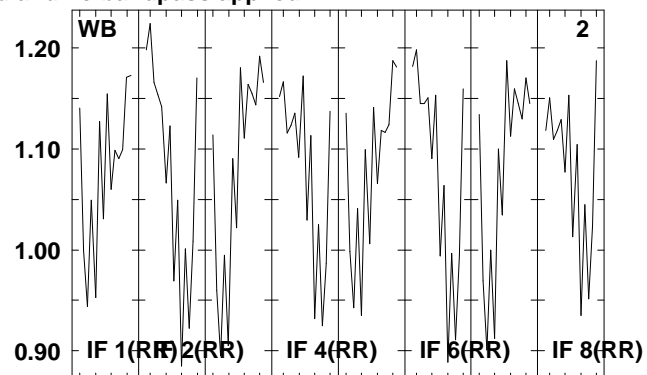
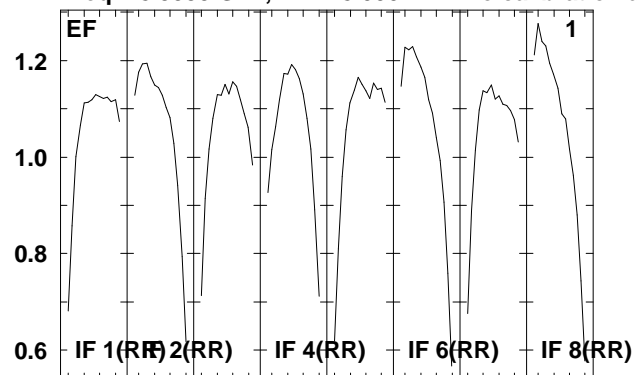

Lower frame: Real Jy  
Total-power spectrum Antenna: \*  
Timerange: 00/21:38:46 to 00/21:42:14

Plot file version 92 created 05-OCT-2009 09:28:31

J1651+01 EH023B 2.UVDATA.1

Freq = 8.3535 GHz, Bw = 8.000 MH No calibration applied and no bandpass applied

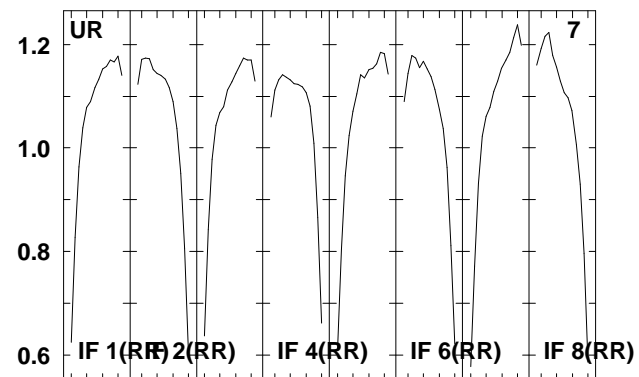
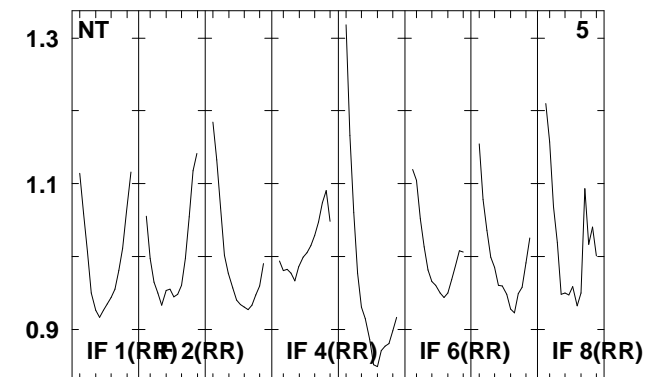
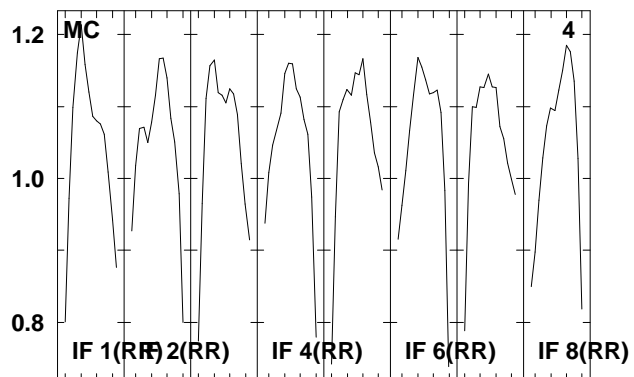
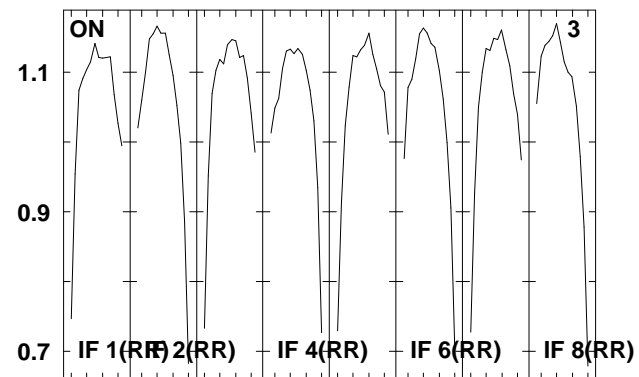
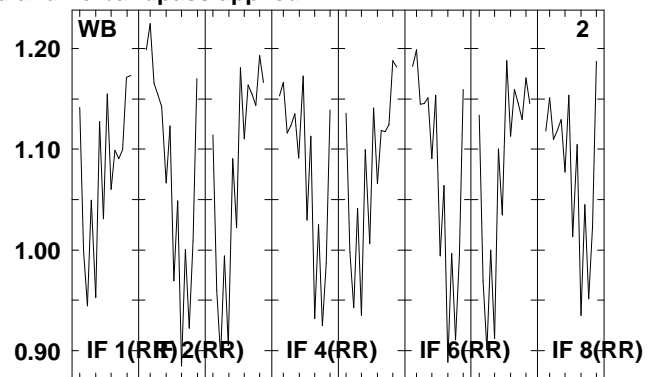
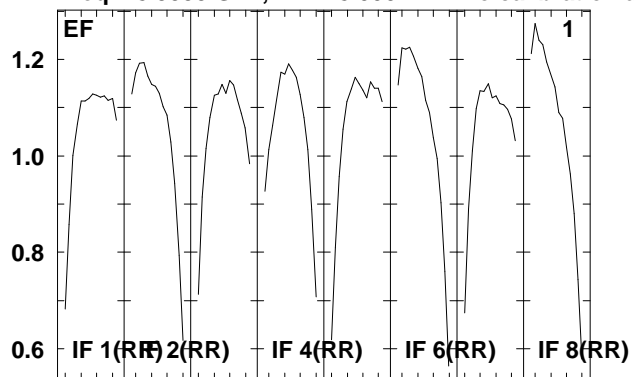

Lower frame: Real Jy  
Total-power spectrum Antenna: \*  
Timerange: 00/21:42:46 to 00/21:44:14

Plot file version 93 created 05-OCT-2009 09:28:31

NGC6240 EH023B 2.UVDATA.1

Freq = 8.3535 GHz, Bw = 8.000 MH No calibration applied and no bandpass applied

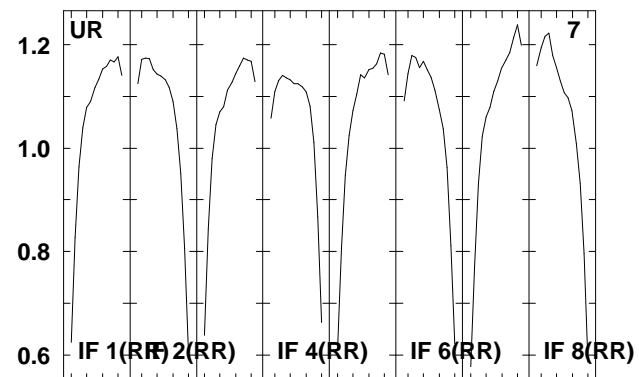
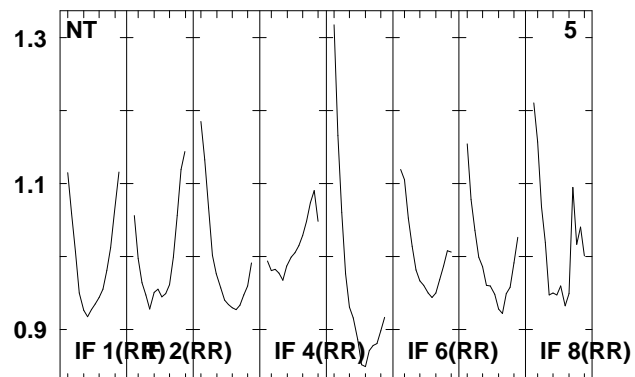
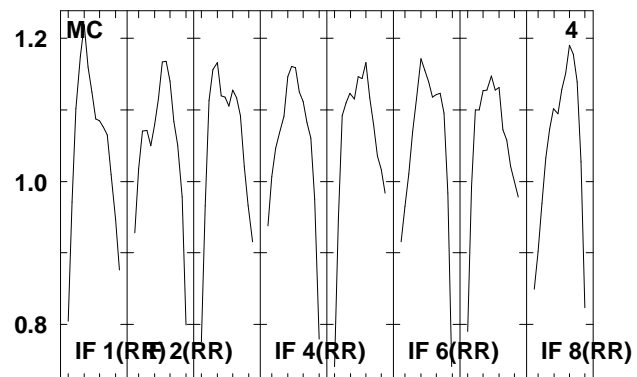
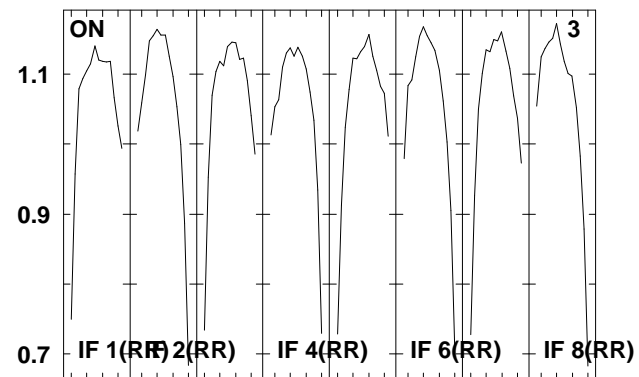
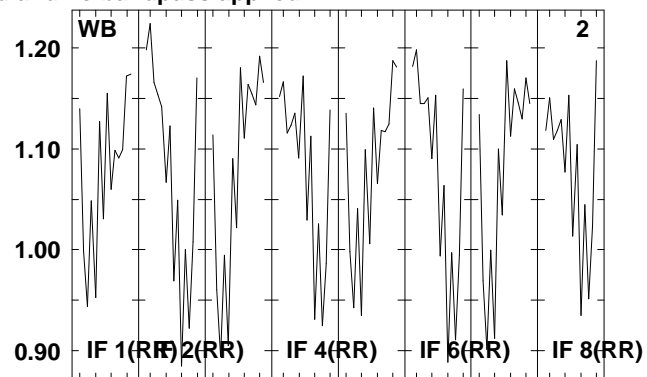
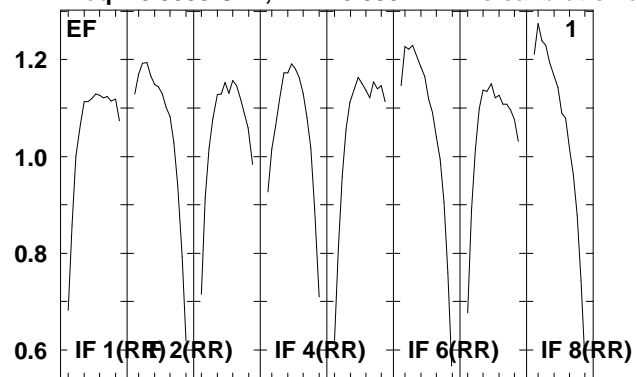

Lower frame: Real Jy  
Total-power spectrum Antenna: \*  
Timerange: 00/21:44:16 to 00/21:47:44

Plot file version 94 created 05-OCT-2009 09:28:31

J1651+01 EH023B 2.UVDATA.1

Freq = 8.3535 GHz, Bw = 8.000 MH No calibration applied and no bandpass applied

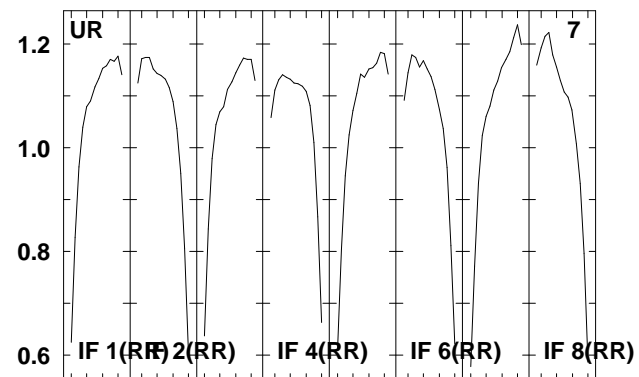
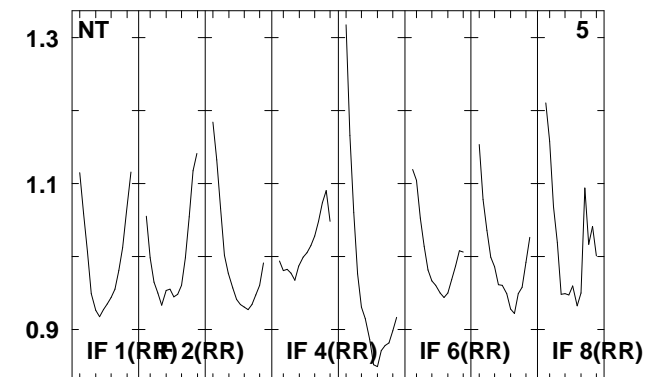
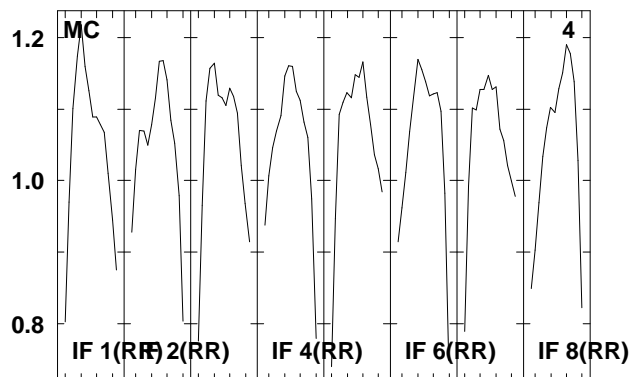
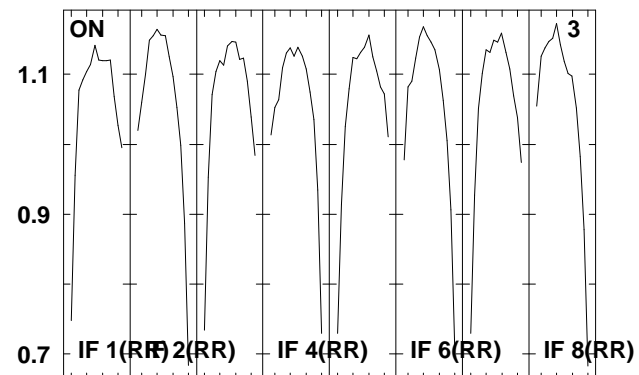
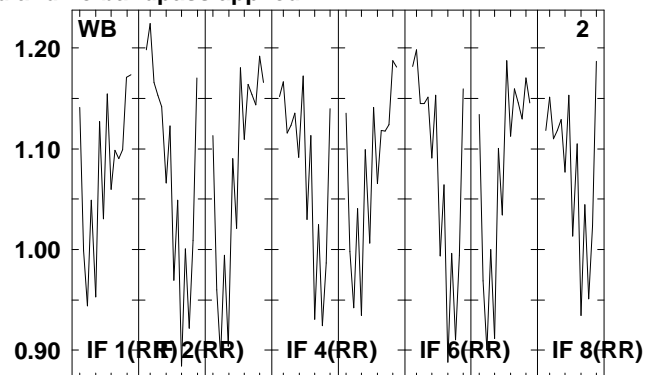
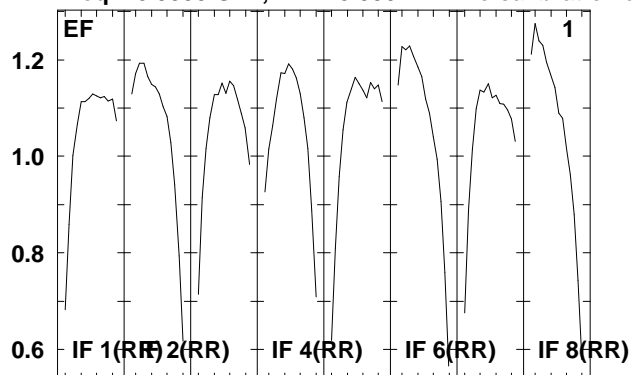

Lower frame: Real Jy  
Total-power spectrum Antenna: \*  
Timerange: 00/21:47:46 to 00/21:49:14

Plot file version 95 created 05-OCT-2009 09:28:31

NGC6240 EH023B 2.UVDATA.1

Freq = 8.3535 GHz, Bw = 8.000 MH No calibration applied and no bandpass applied

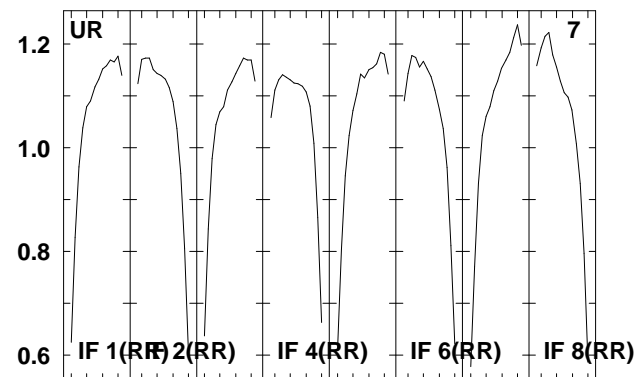
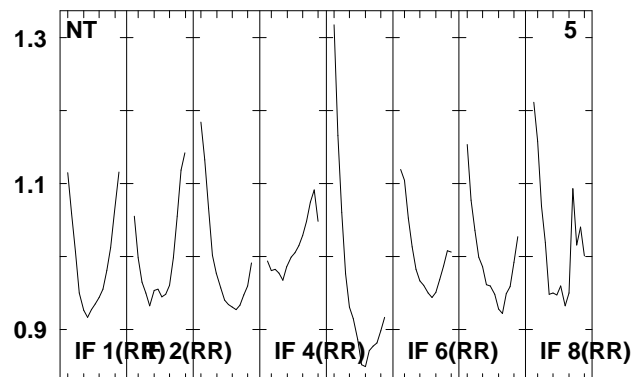
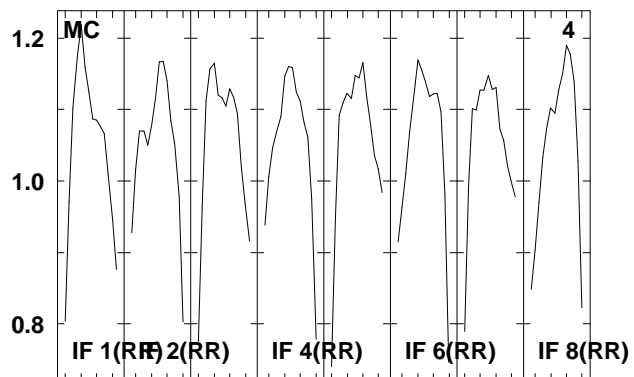
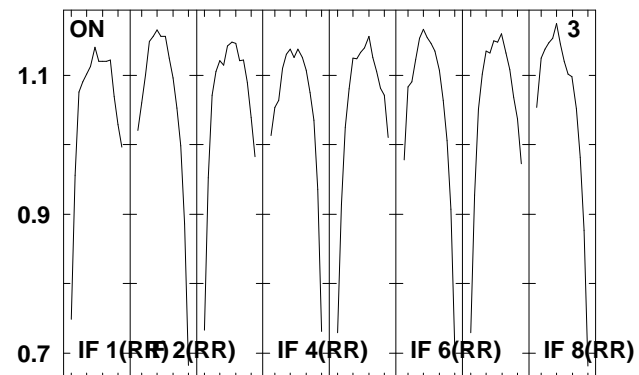
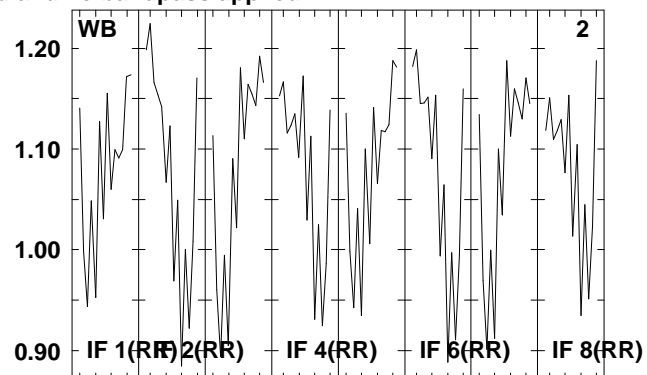
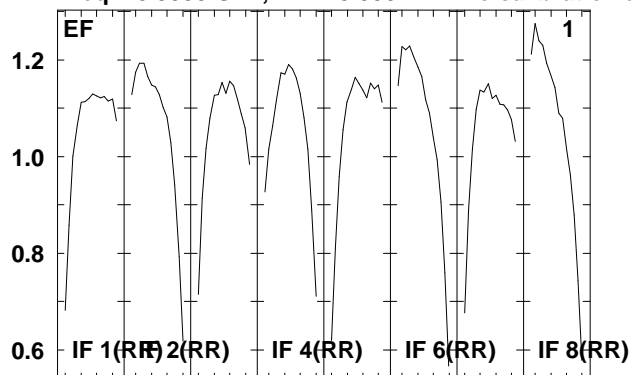

Lower frame: Real Jy  
Total-power spectrum Antenna: \*  
Timerange: 00/21:49:16 to 00/21:52:44

Plot file version 96 created 05-OCT-2009 09:28:32

J1651+01 EH023B 2.UVDATA.1

Freq = 8.3535 GHz, Bw = 8.000 MH No calibration applied and no bandpass applied

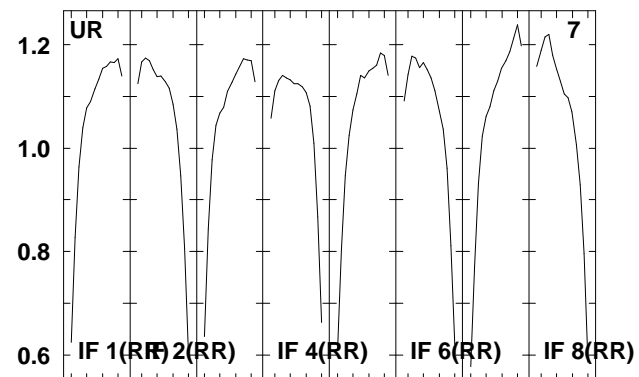
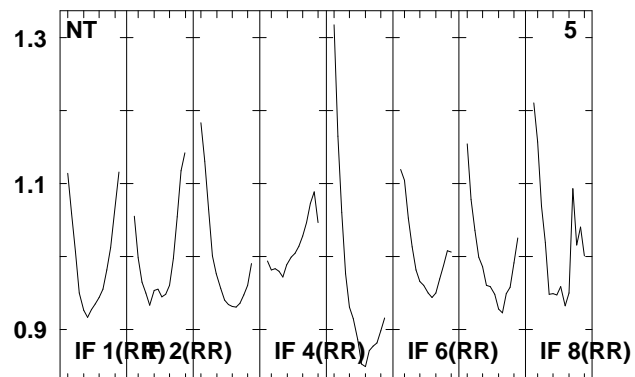
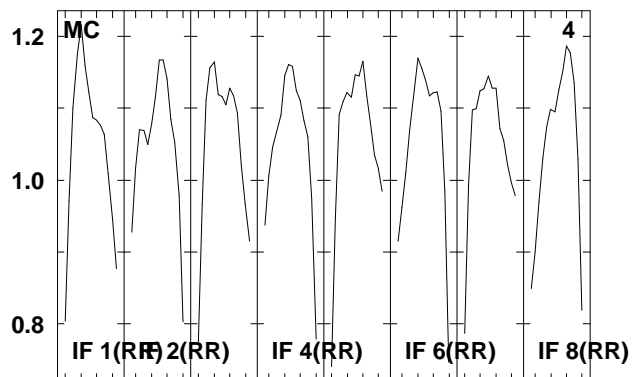
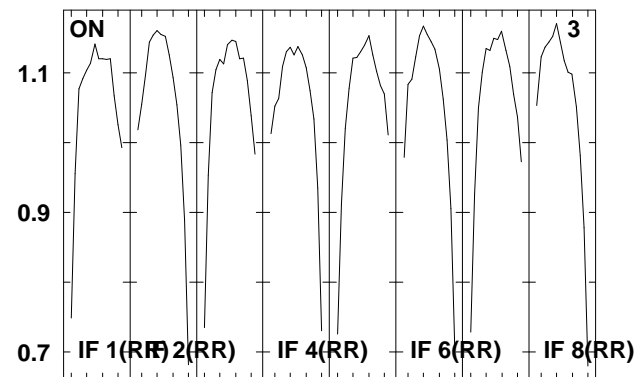
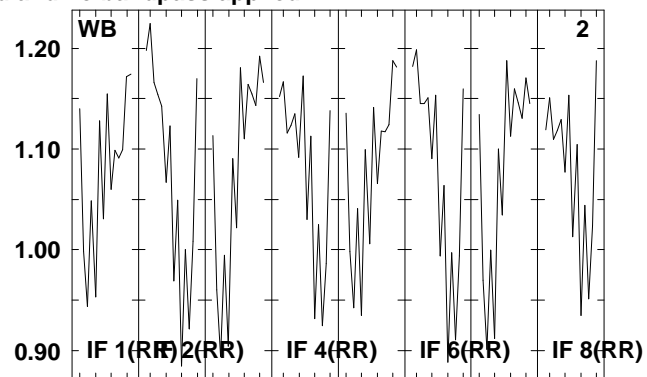
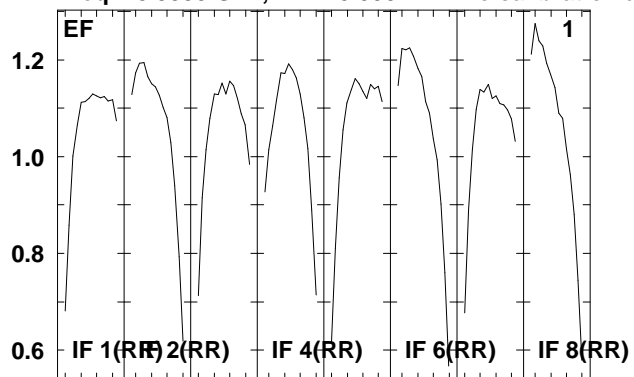

Lower frame: Real Jy  
Total-power spectrum Antenna: \*  
Timerange: 00/21:53:16 to 00/21:54:44



Plot file version 97 created 05-OCT-2009 09:28:32

NGC6240 EH023B 2.UVDATA.1

Freq = 8.3535 GHz, Bw = 8.000 MH No calibration applied and no bandpass applied

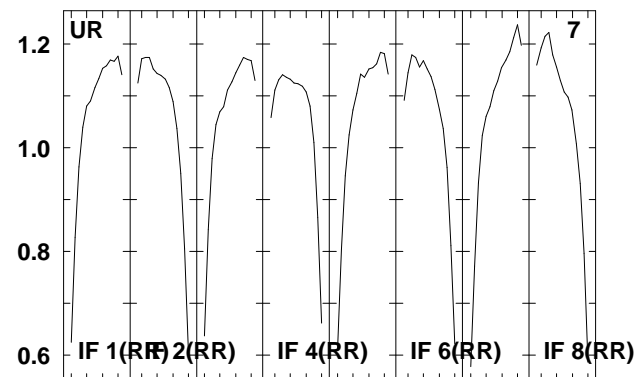
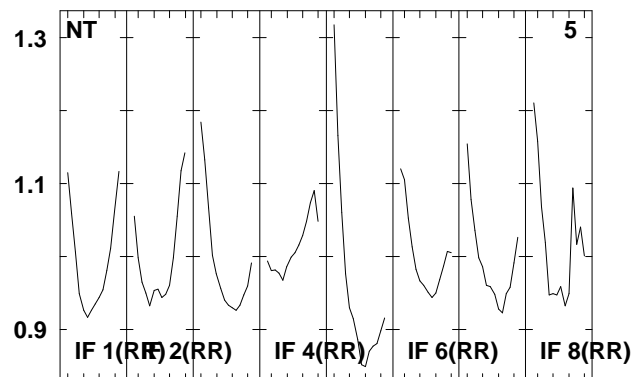
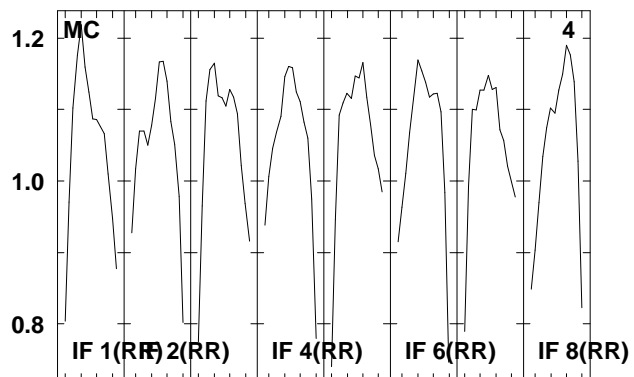
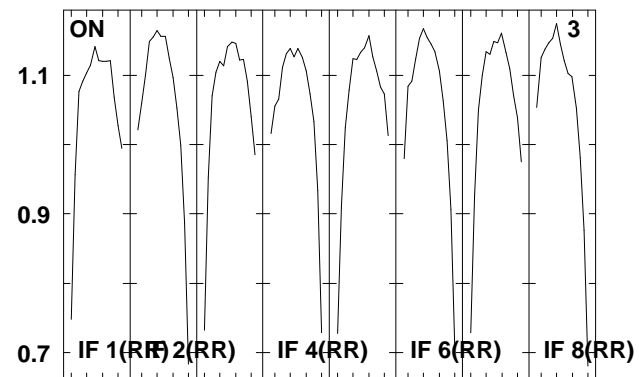
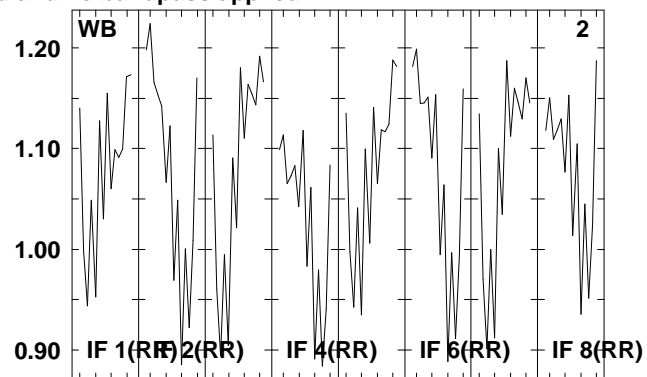
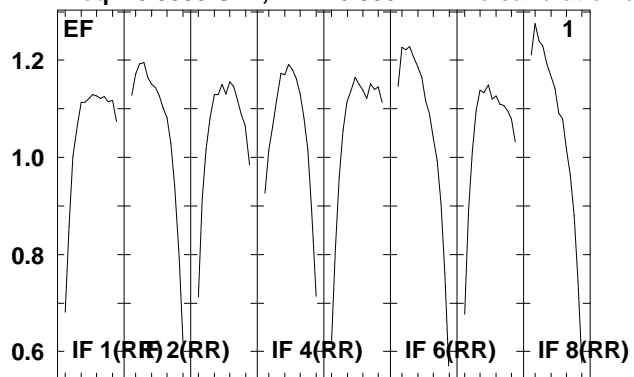

Lower frame: Real Jy  
Total-power spectrum Antenna: \*  
Timerange: 00/21:54:46 to 00/21:58:14

Plot file version 98 created 05-OCT-2009 09:28:32

J1651+01 EH023B 2.UVDATA.1

Freq = 8.3535 GHz, Bw = 8.000 MH No calibration applied and no bandpass applied

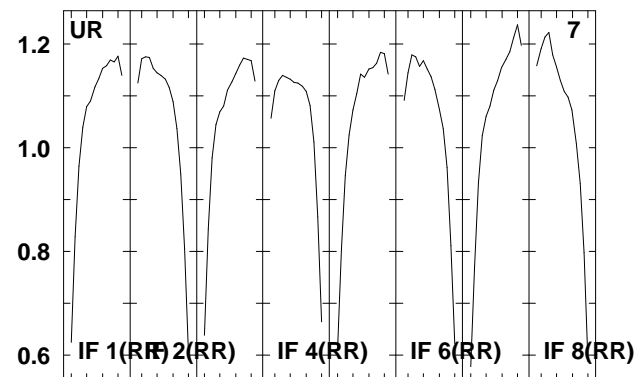
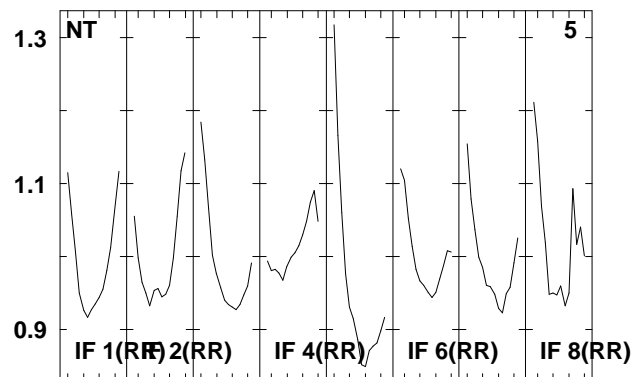
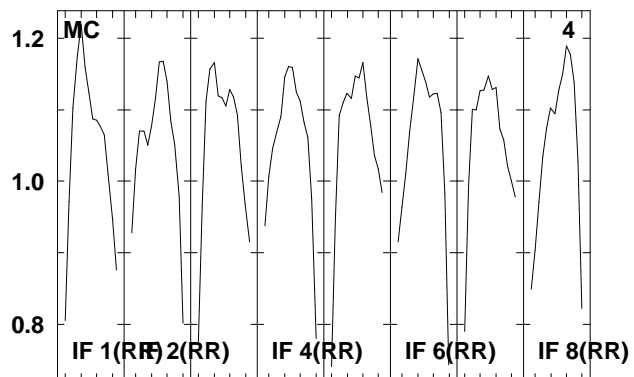
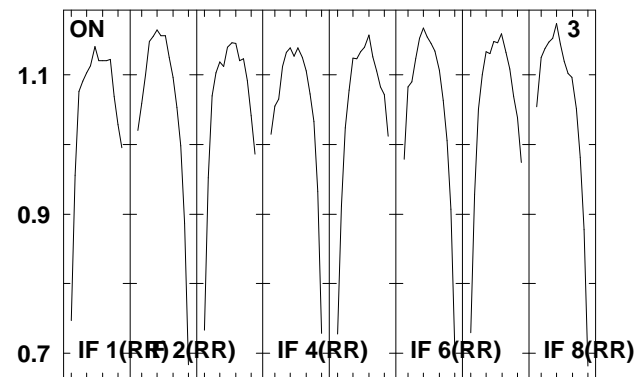
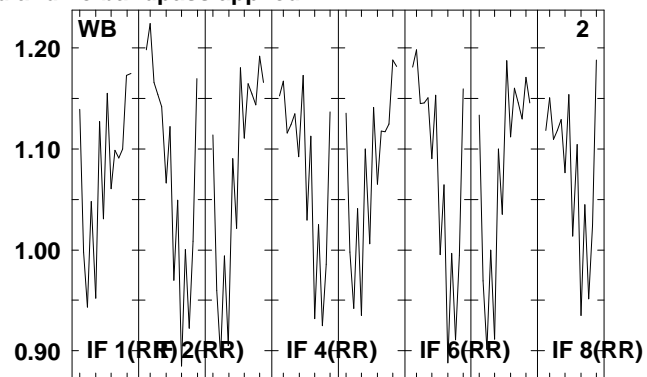
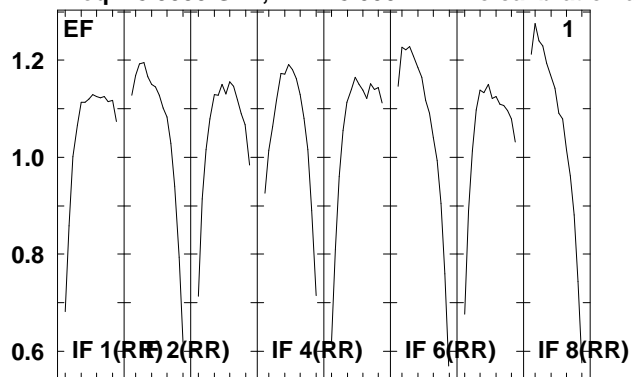

Lower frame: Real Jy  
Total-power spectrum Antenna: \*  
Timerange: 00/21:58:16 to 00/21:59:44

Plot file version 99 created 05-OCT-2009 09:28:32

NGC6240 EH023B 2.UVDATA.1

Freq = 8.3535 GHz, Bw = 8.000 MH No calibration applied and no bandpass applied

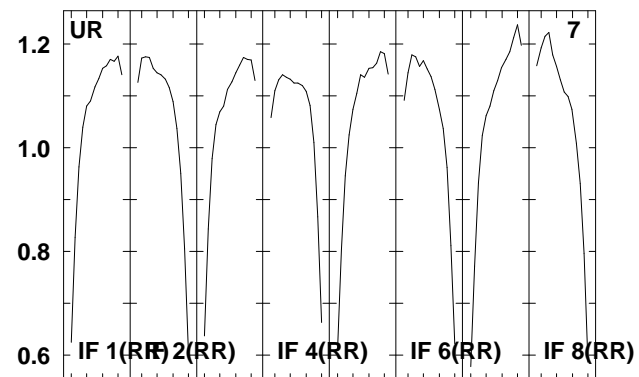
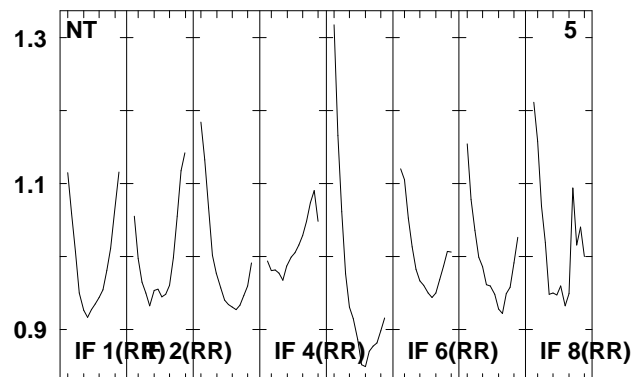
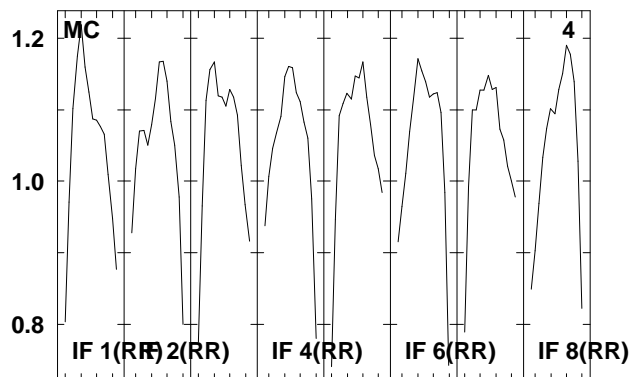
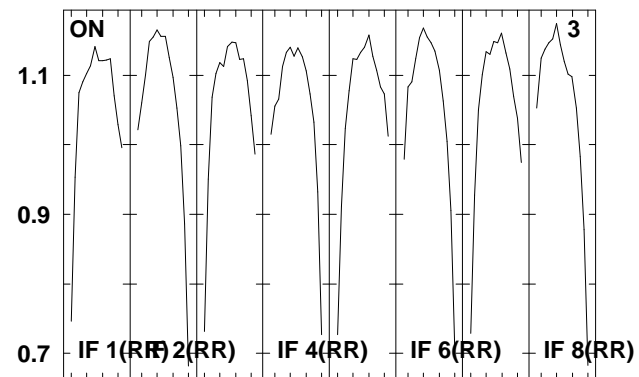
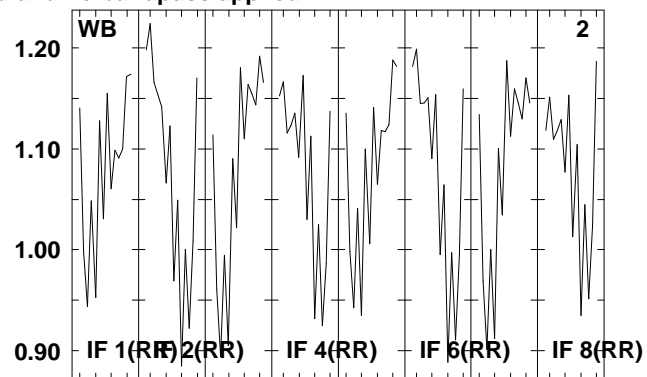
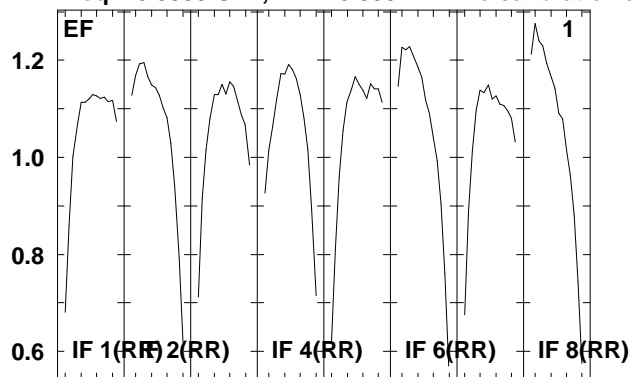

Lower frame: Real Jy  
Total-power spectrum Antenna: \*  
Timerange: 00/21:59:46 to 00/22:03:14

Plot file version 100 created 05-OCT-2009 09:28:32

J1651+01 EH023B 2.UVDATA.1

Freq = 8.3535 GHz, Bw = 8.000 MH No calibration applied and no bandpass applied

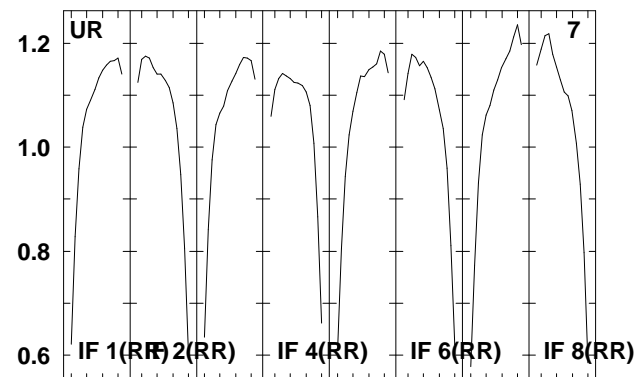
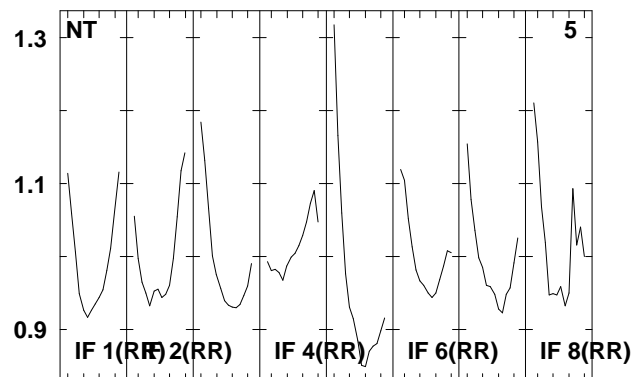
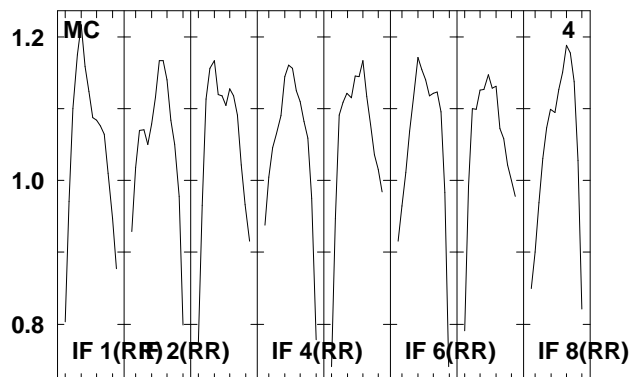
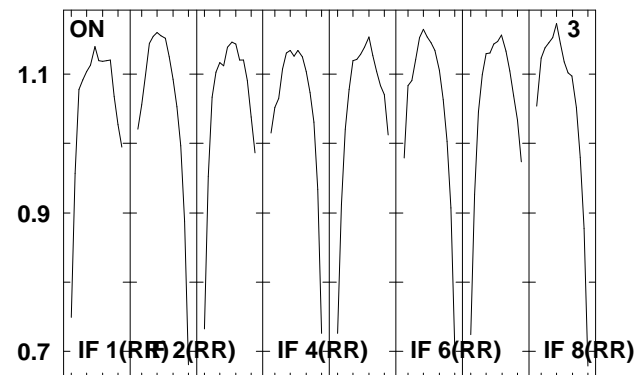
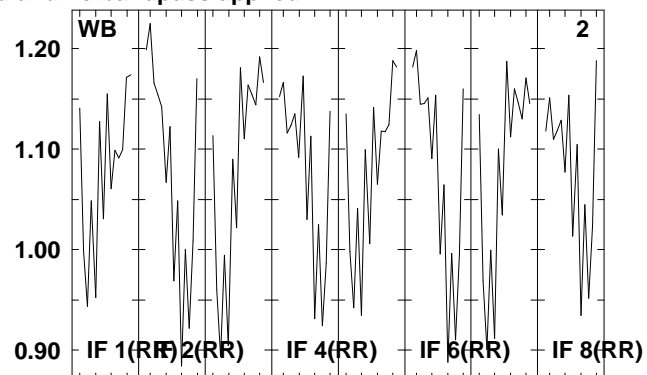
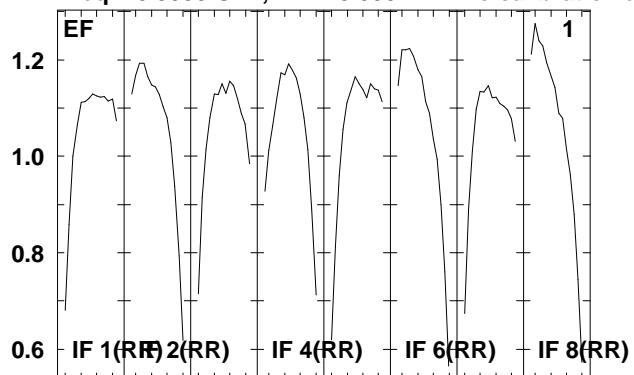

Lower frame: Real Jy  
Total-power spectrum Antenna: \*  
Timerange: 00/22:03:46 to 00/22:05:14

Plot file version 101 created 05-OCT-2009 09:28:32

NGC6240 EH023B 2.UVDATA.1

Freq = 8.3535 GHz, Bw = 8.000 MH No calibration applied and no bandpass applied

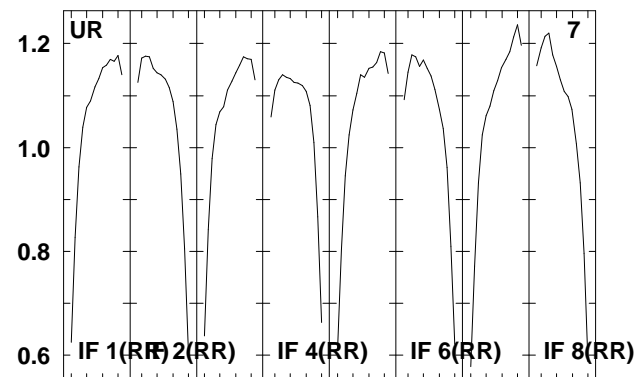
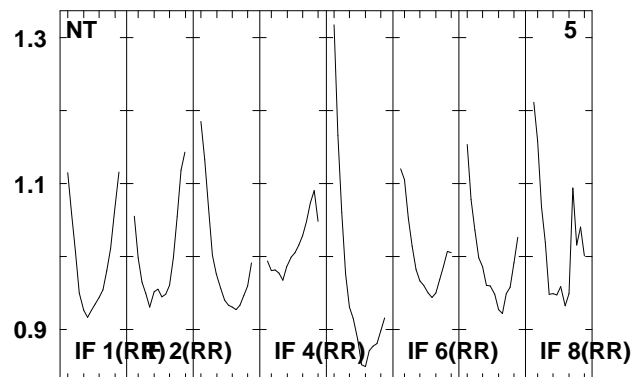
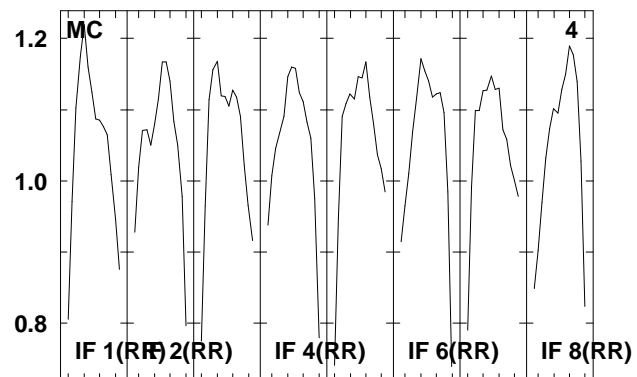
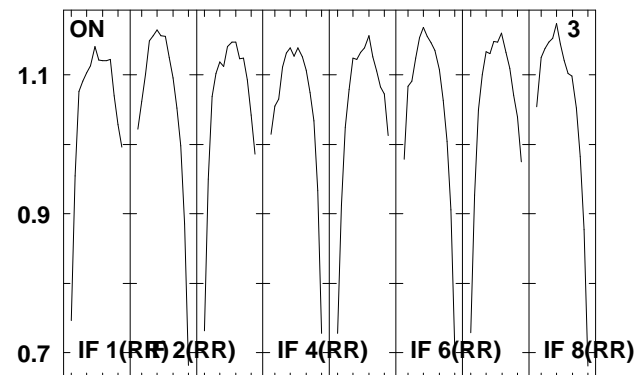
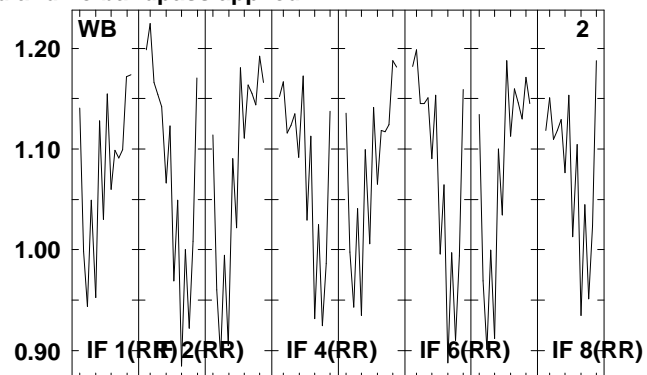
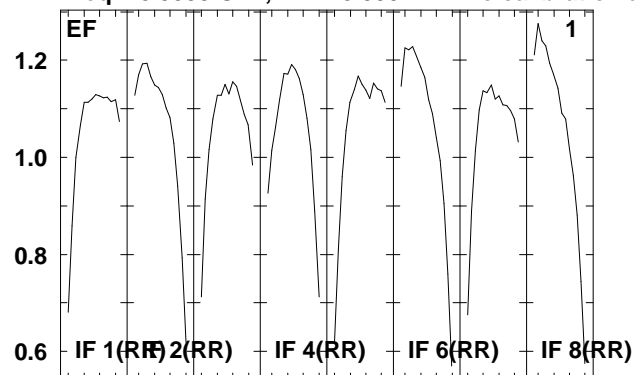

Lower frame: Real Jy  
Total-power spectrum Antenna: \*  
Timerange: 00/22:05:16 to 00/22:08:44

Plot file version 102 created 05-OCT-2009 09:28:33

J1651+01 EH023B 2.UVDATA.1

Freq = 8.3535 GHz, Bw = 8.000 MH No calibration applied and no bandpass applied

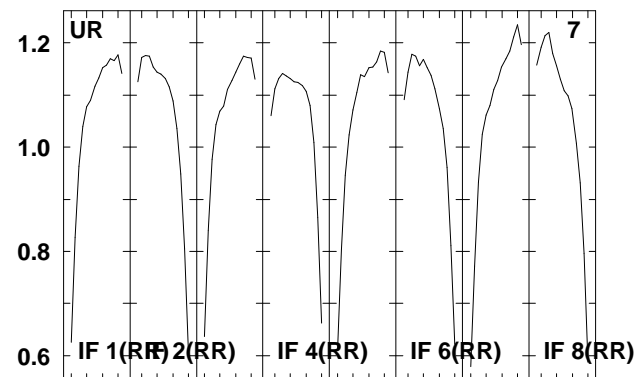
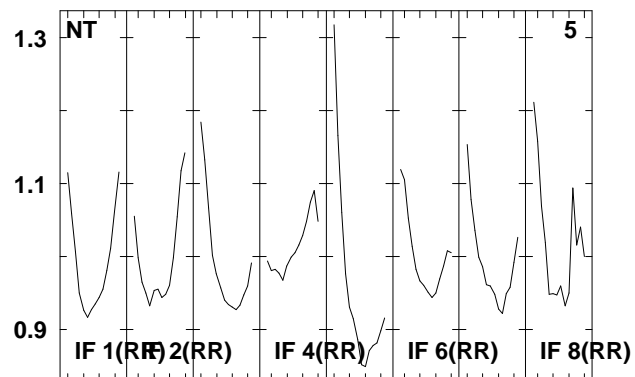
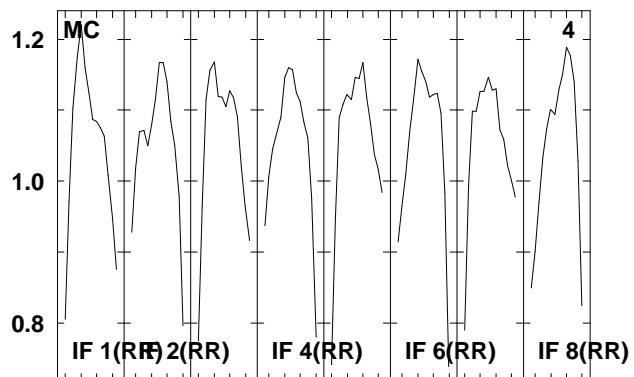
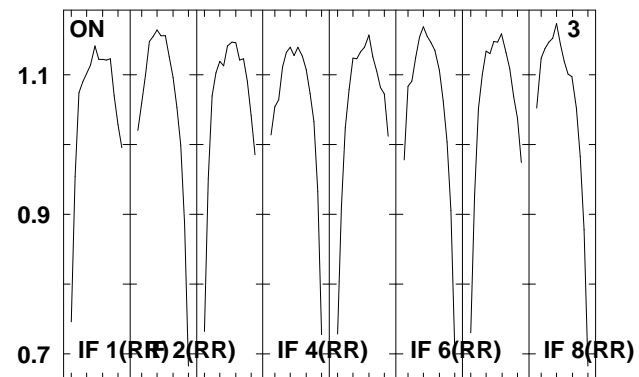
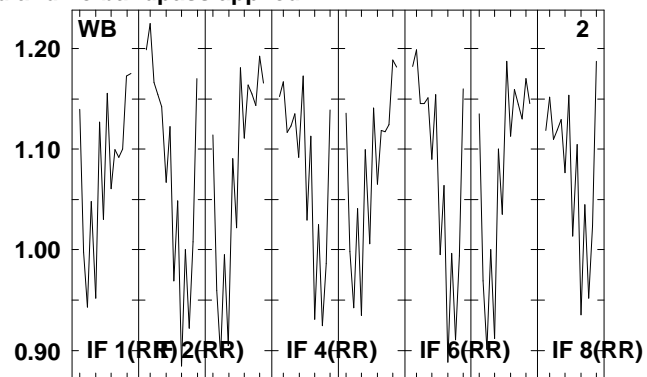
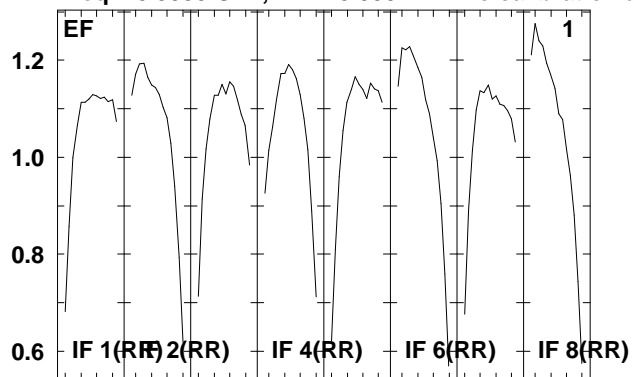

Lower frame: Real Jy  
Total-power spectrum Antenna: \*  
Timerange: 00/22:08:46 to 00/22:10:14

Plot file version 103 created 05-OCT-2009 09:28:33

NGC6240 EH023B 2.UVDATA.1

Freq = 8.3535 GHz, Bw = 8.000 MH No calibration applied and no bandpass applied

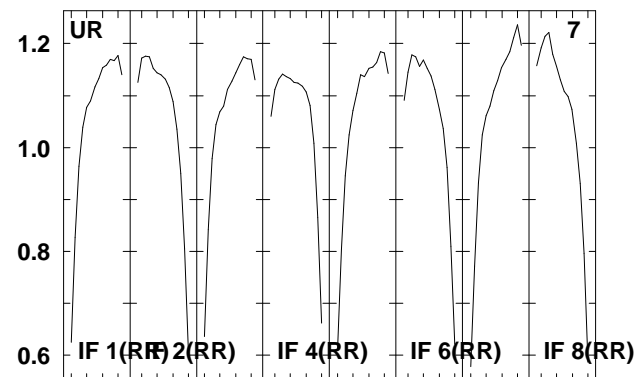
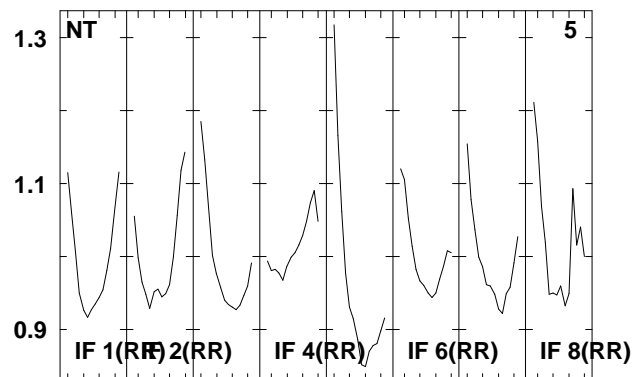
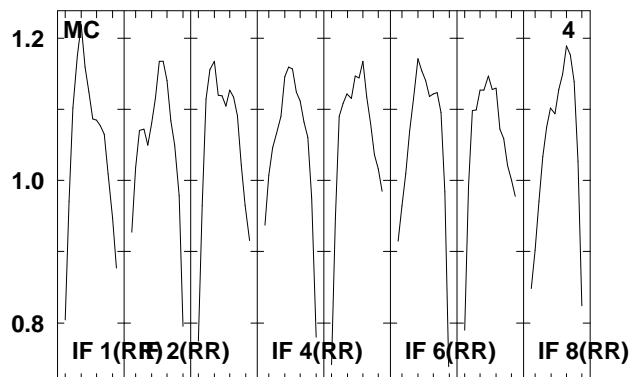
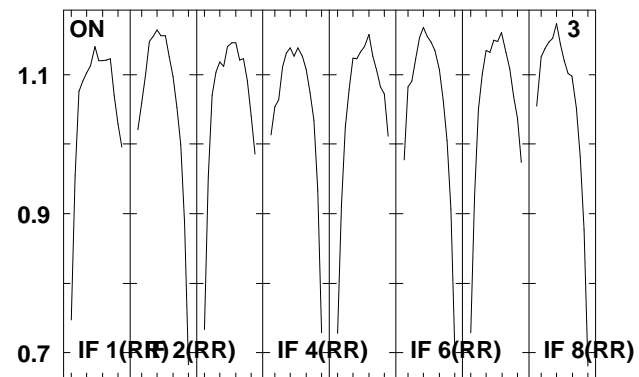
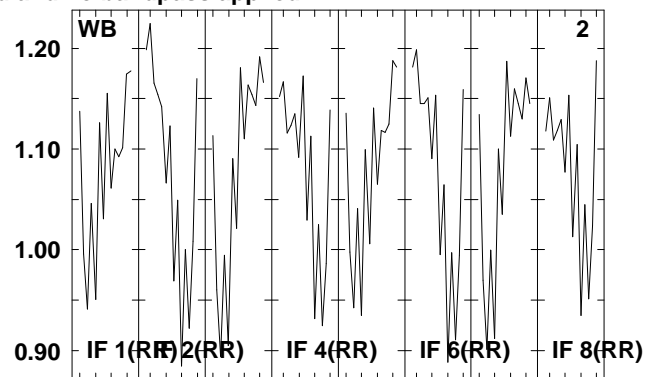
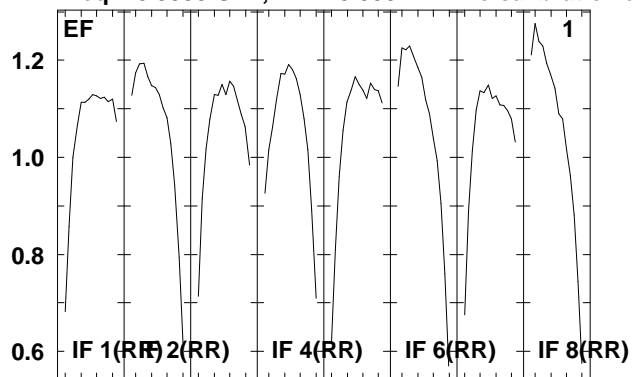

Lower frame: Real Jy  
Total-power spectrum Antenna: \*  
Timerange: 00/22:10:16 to 00/22:13:42

Plot file version 104 created 05-OCT-2009 09:28:33

J1651+01 EH023B 2.UVDATA.1

Freq = 8.3535 GHz, Bw = 8.000 MH No calibration applied and no bandpass applied

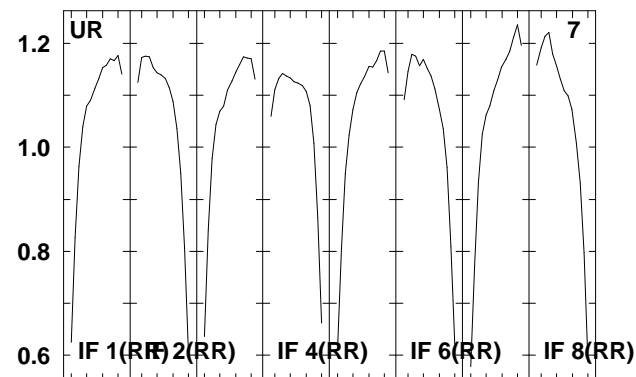
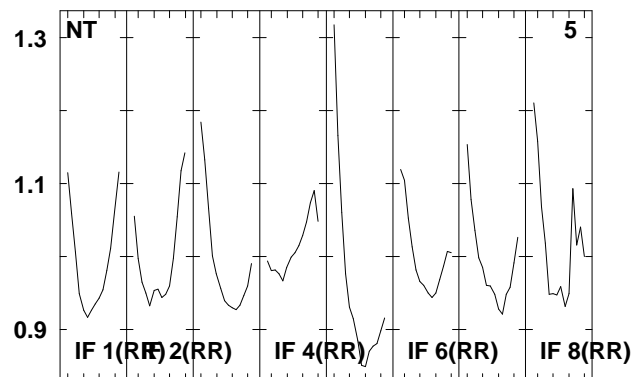
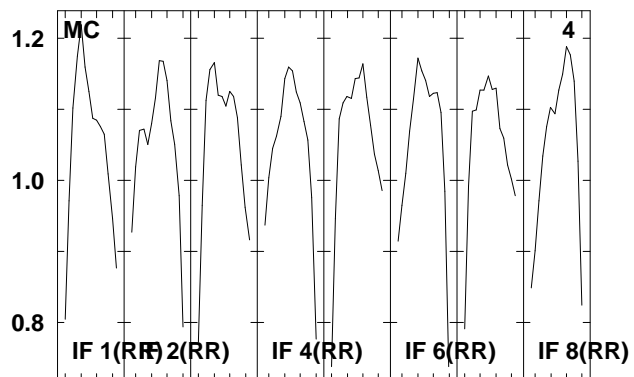
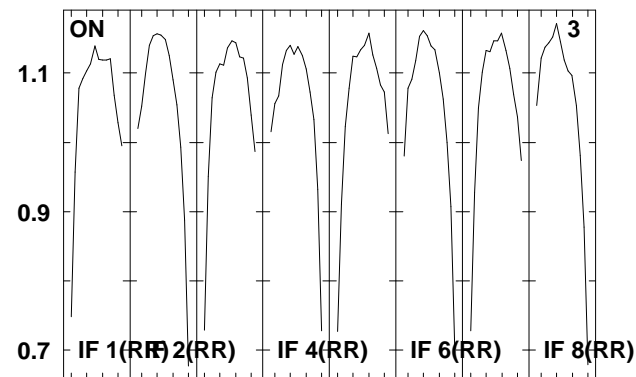
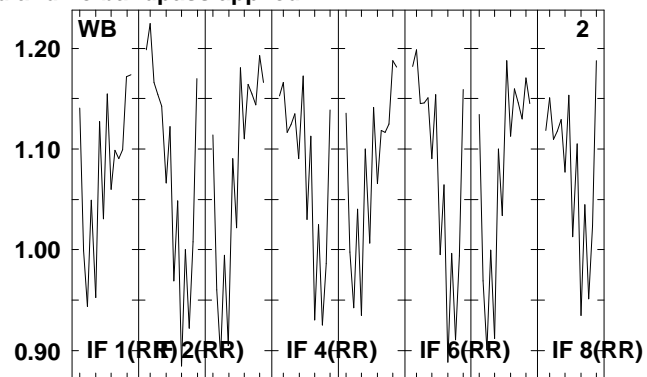
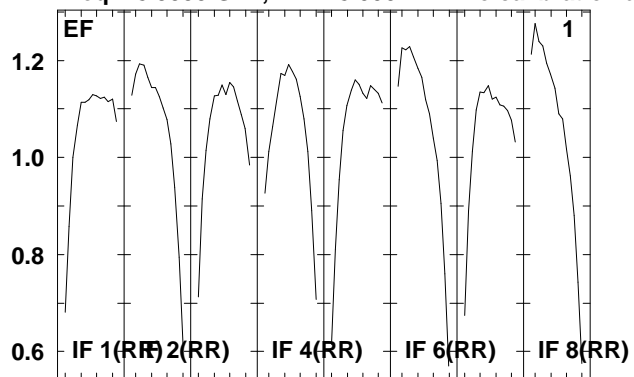

Lower frame: Real Jy  
Total-power spectrum Antenna: \*  
Timerange: 00/22:14:16 to 00/22:15:44



Plot file version 105 created 05-OCT-2009 09:28:33

NGC6240 EH023B 2.UVDATA.1

Freq = 8.3535 GHz, Bw = 8.000 MH No calibration applied and no bandpass applied

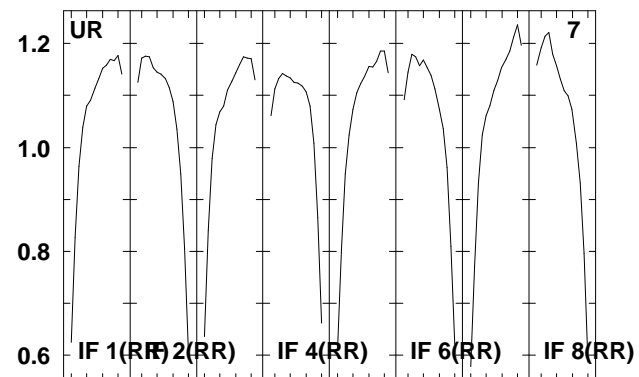
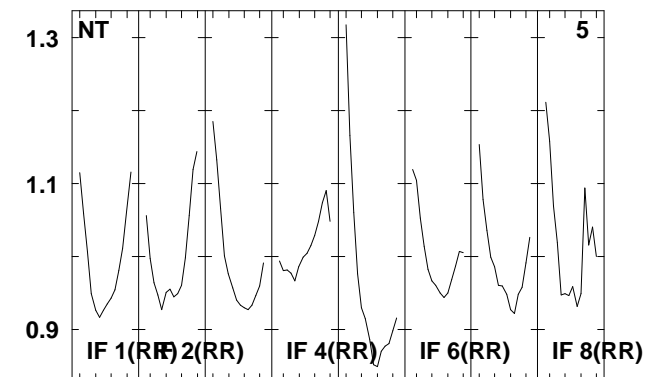
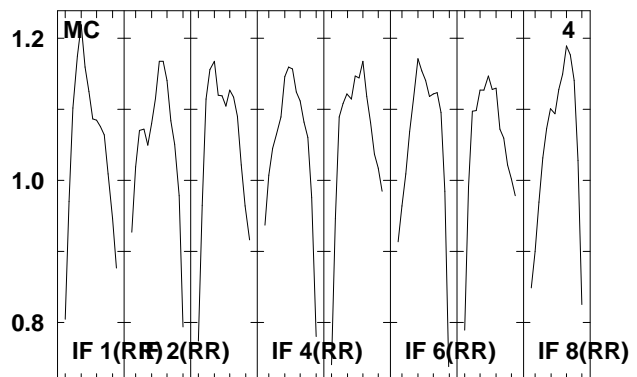
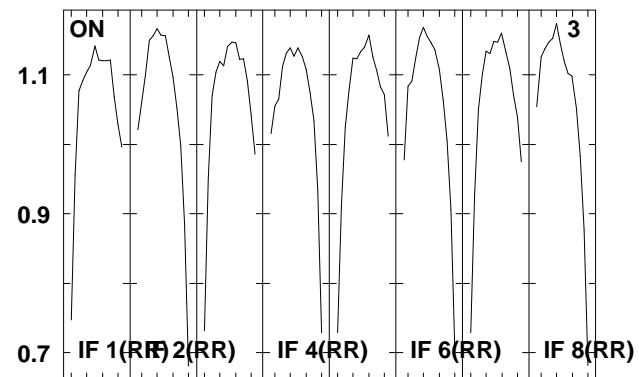
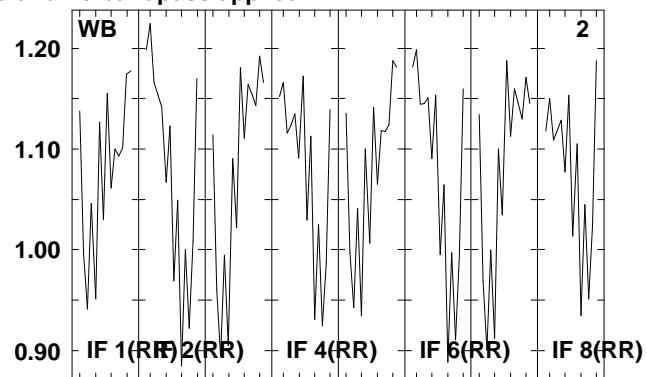
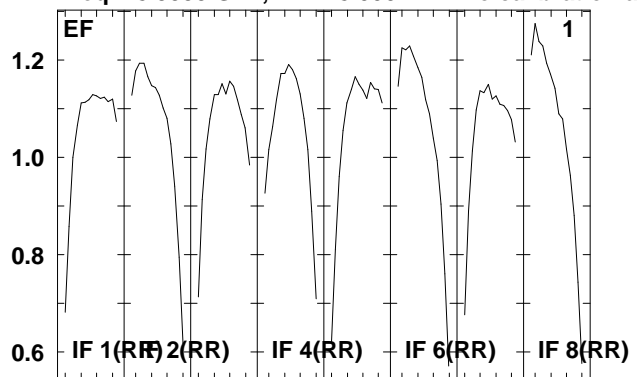

Lower frame: Real Jy  
Total-power spectrum Antenna: \*  
Timerange: 00/22:15:46 to 00/22:19:14

Plot file version 106 created 05-OCT-2009 09:28:33

J1651+01 EH023B 2.UVDATA.1

Freq = 8.3535 GHz, Bw = 8.000 MH No calibration applied and no bandpass applied

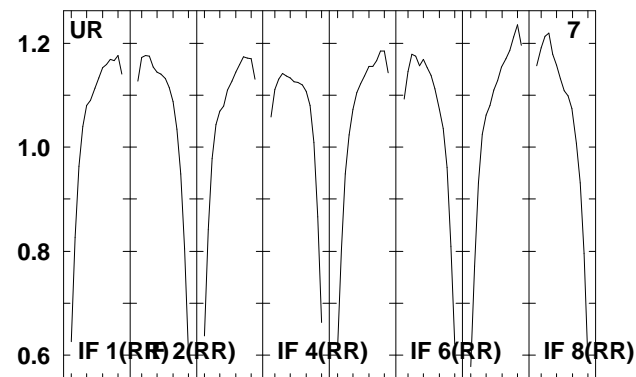
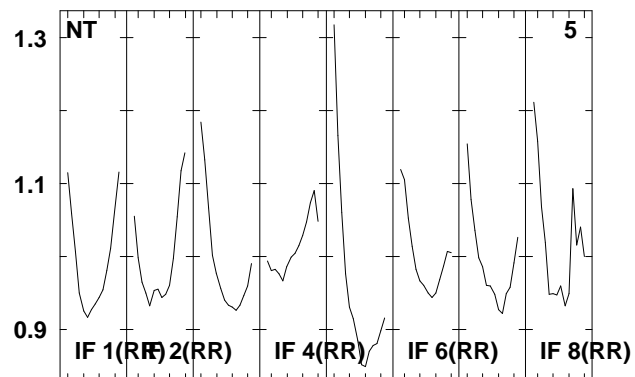
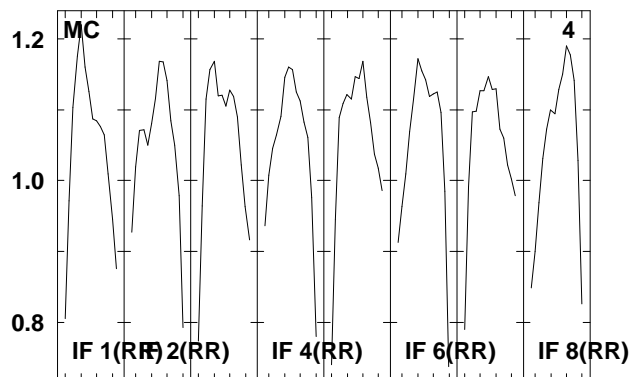
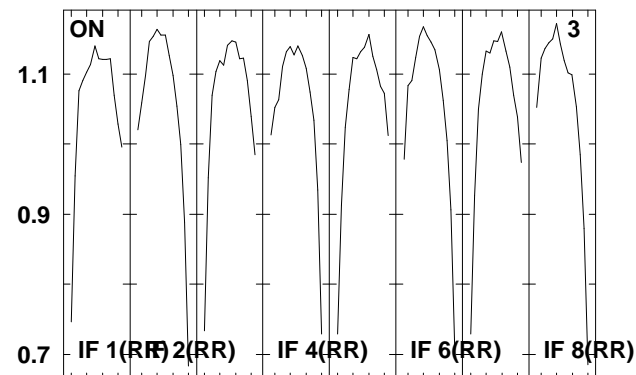
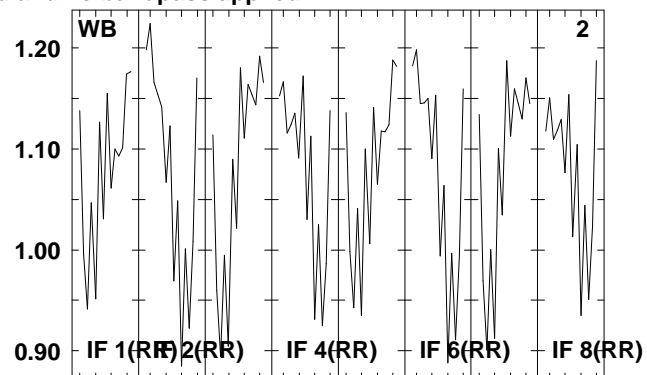
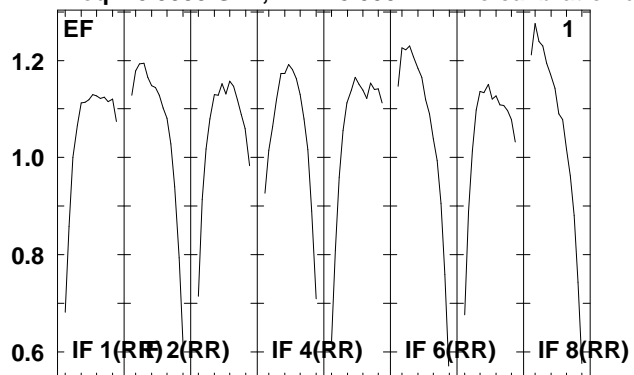

Lower frame: Real Jy  
Total-power spectrum Antenna: \*  
Timerange: 00/22:19:16 to 00/22:20:44

Plot file version 107 created 05-OCT-2009 09:28:33

NGC6240 EH023B 2.UVDATA.1

Freq = 8.3535 GHz, Bw = 8.000 MH No calibration applied and no bandpass applied

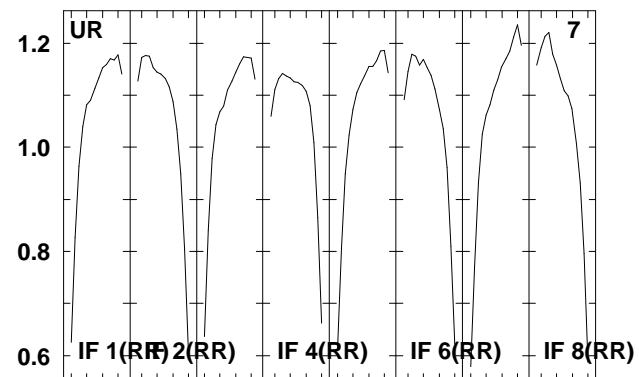
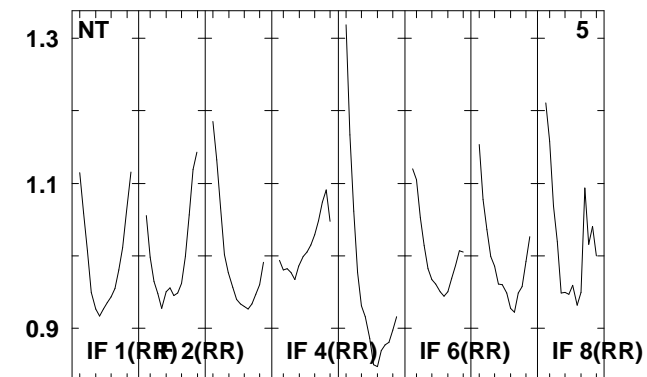
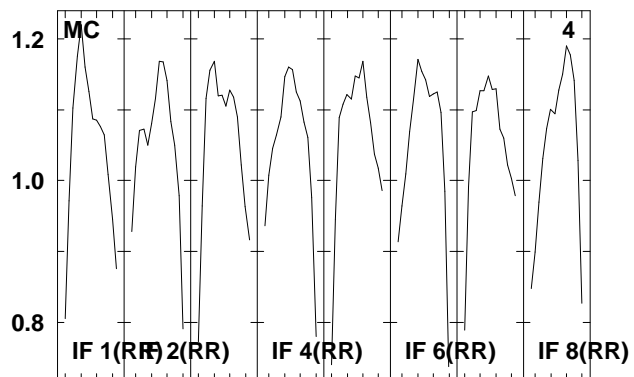
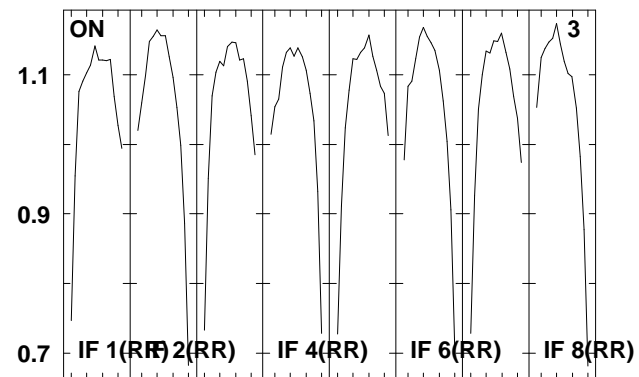
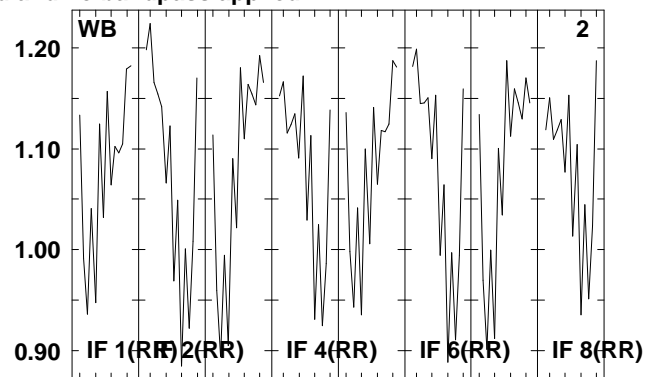
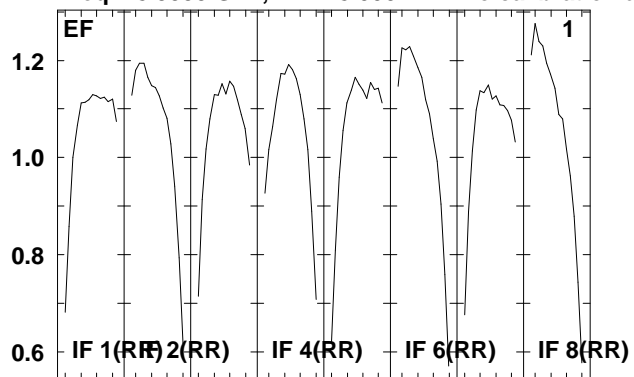

Lower frame: Real Jy  
Total-power spectrum Antenna: \*  
Timerange: 00/22:20:46 to 00/22:24:14

Plot file version 108 created 05-OCT-2009 09:28:33

J1651+01 EH023B 2.UVDATA.1

Freq = 8.3535 GHz, Bw = 8.000 MH No calibration applied and no bandpass applied

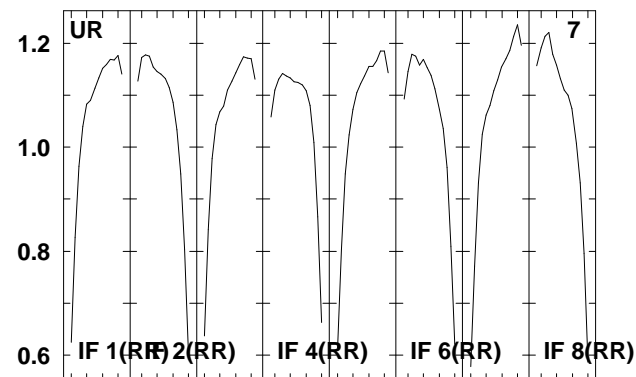
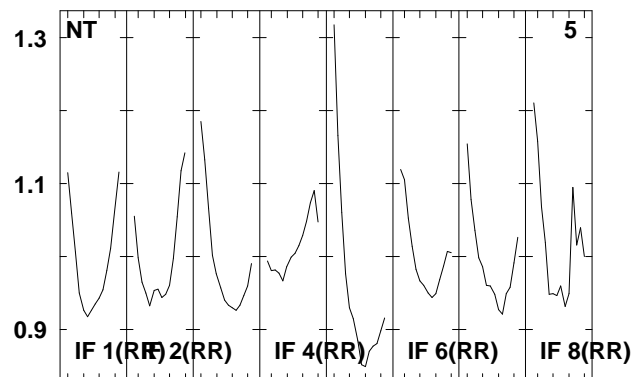
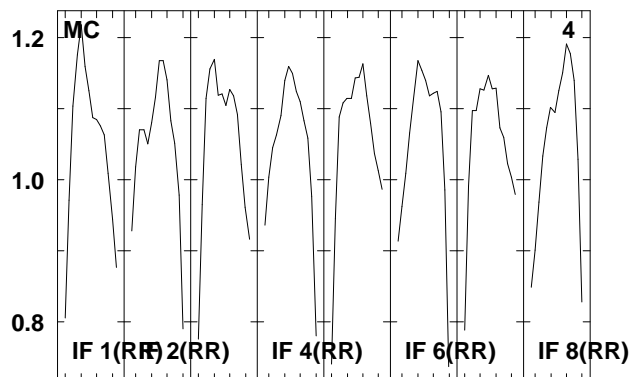
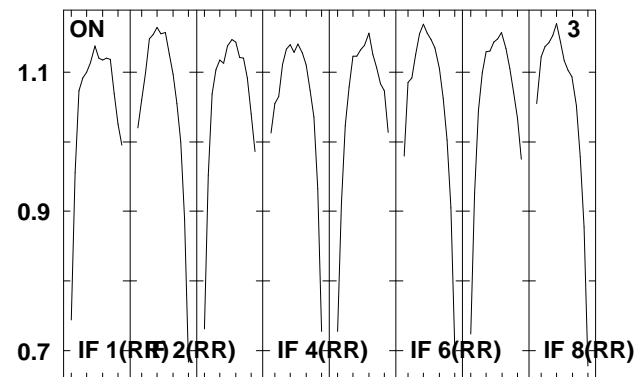
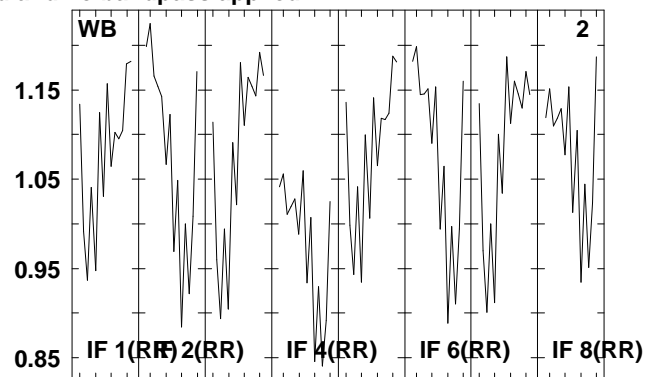
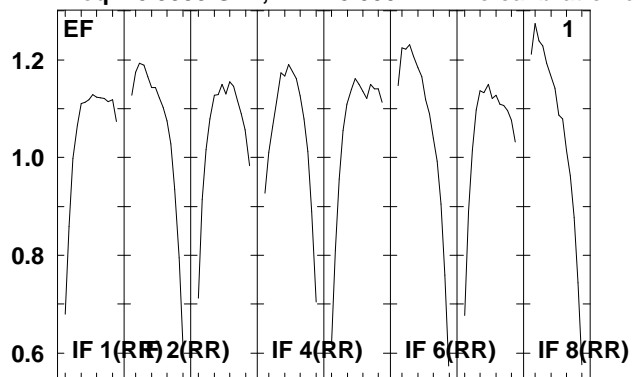

Lower frame: Real Jy  
Total-power spectrum Antenna: \*  
Timerange: 00/22:24:46 to 00/22:26:14

Plot file version 109 created 05-OCT-2009 09:28:34

NGC6240 EH023B 2.UVDATA.1

Freq = 8.3535 GHz, Bw = 8.000 MH No calibration applied and no bandpass applied

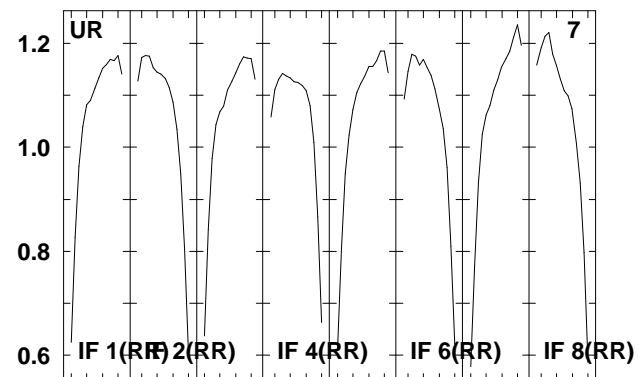
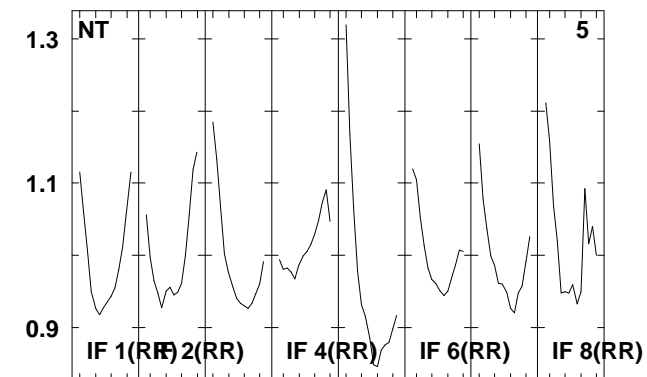
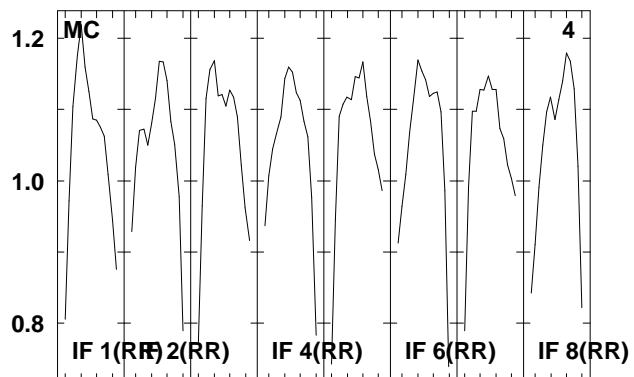
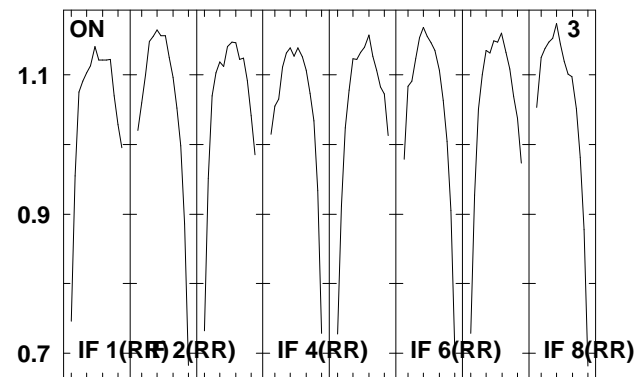
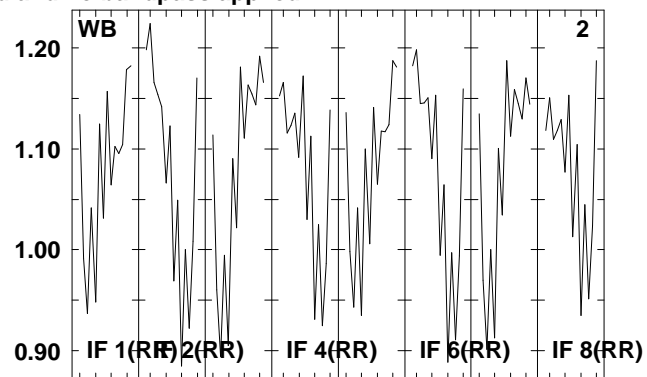
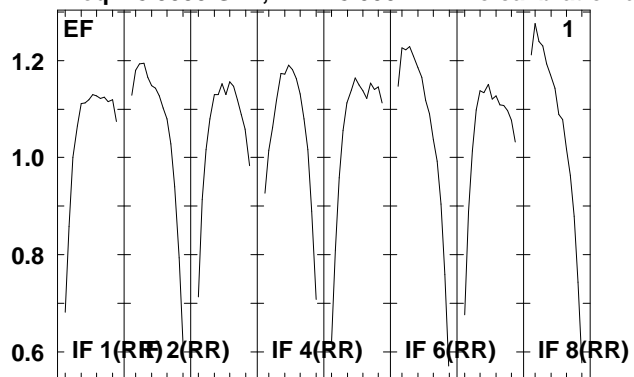

Lower frame: Real Jy  
Total-power spectrum Antenna: \*  
Timerange: 00/22:26:16 to 00/22:29:44

Plot file version 110 created 05-OCT-2009 09:28:34

J1651+01 EH023B 2.UVDATA.1

Freq = 8.3535 GHz, Bw = 8.000 MH No calibration applied and no bandpass applied

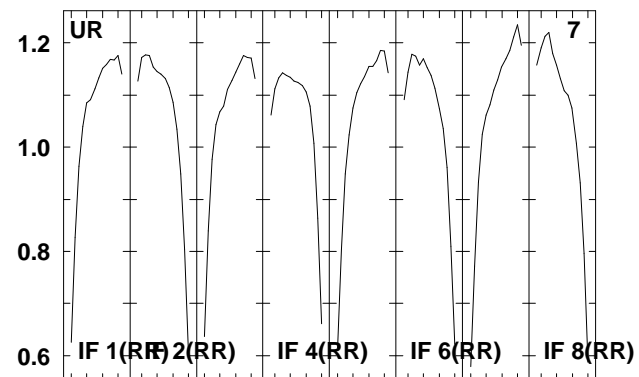
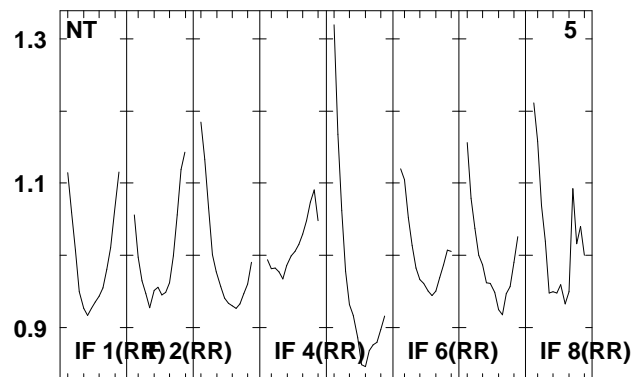
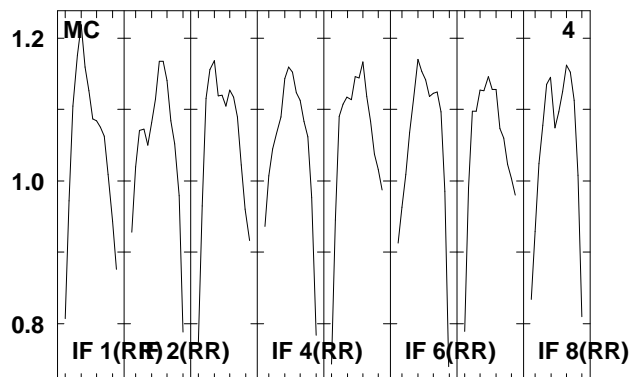
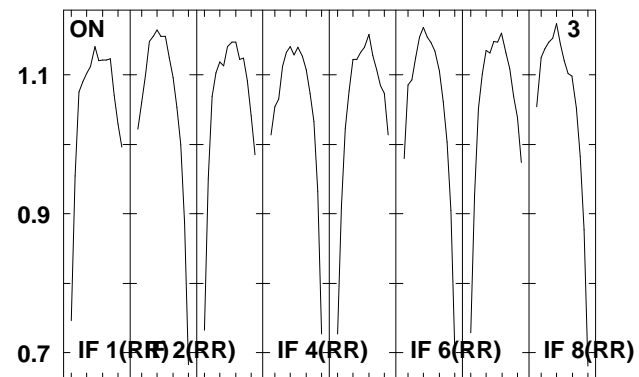
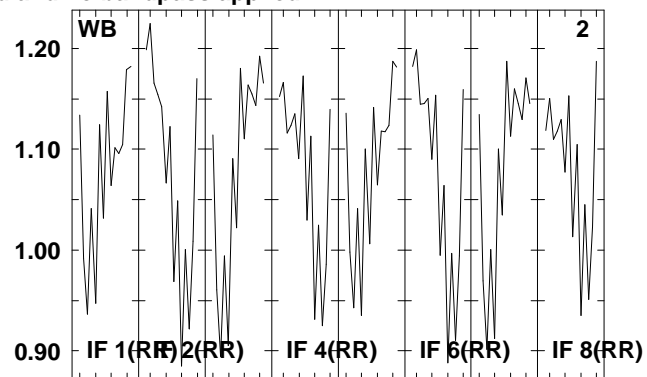
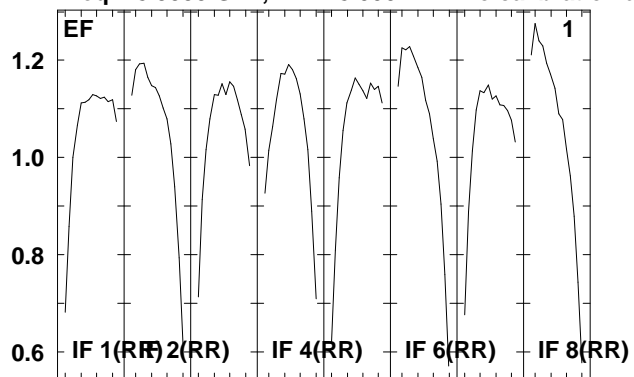

Lower frame: Real Jy  
Total-power spectrum Antenna: \*  
Timerange: 00/22:29:46 to 00/22:31:14

Plot file version 111 created 05-OCT-2009 09:28:34

NGC6240 EH023B 2.UVDATA.1

Freq = 8.3535 GHz, Bw = 8.000 MH No calibration applied and no bandpass applied

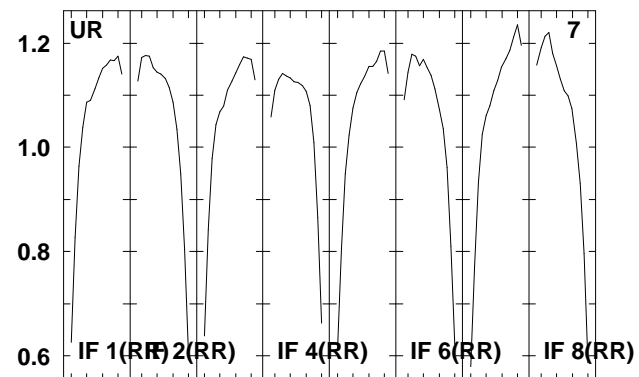
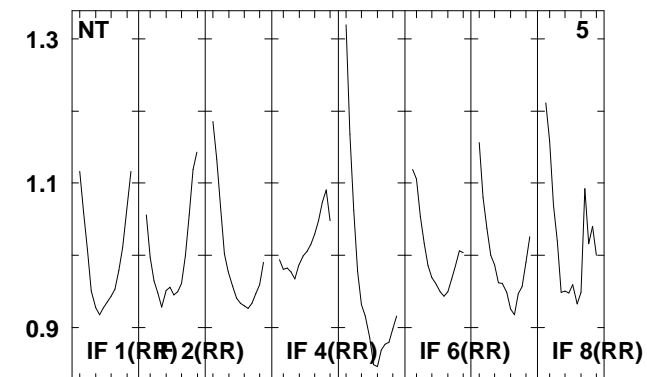
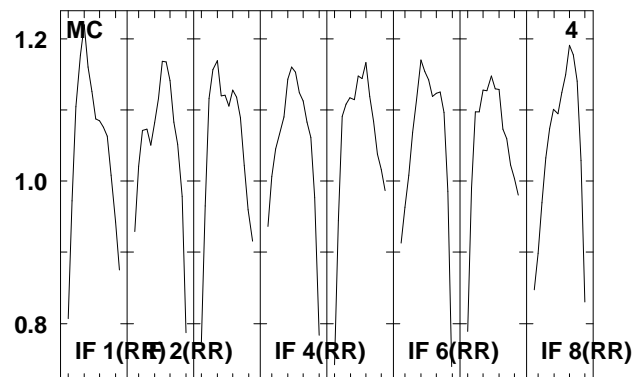
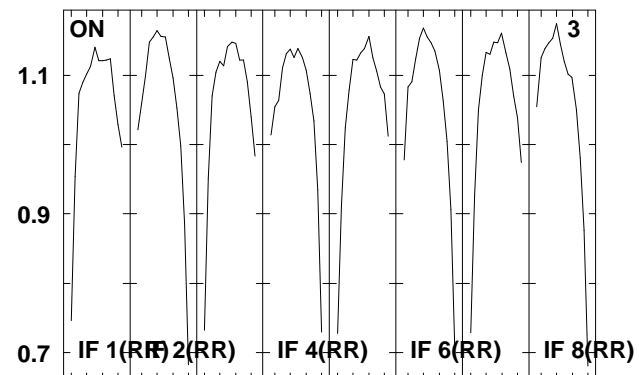
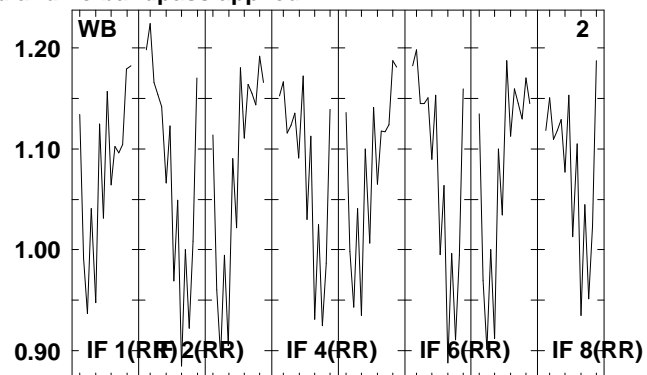
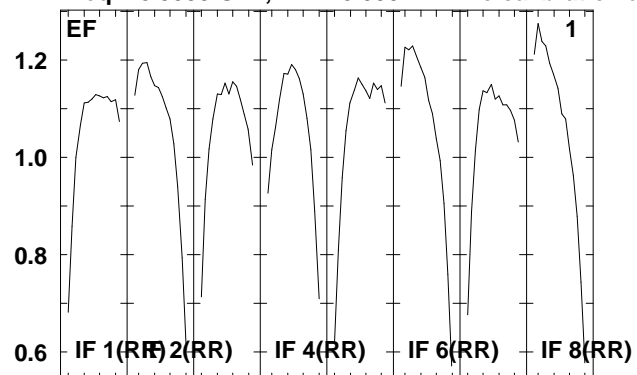

Lower frame: Real Jy  
Total-power spectrum Antenna: \*  
Timerange: 00/22:31:16 to 00/22:34:44

Plot file version 112 created 05-OCT-2009 09:28:34

J1651+01 EH023B 2.UVDATA.1

Freq = 8.3535 GHz, Bw = 8.000 MH No calibration applied and no bandpass applied

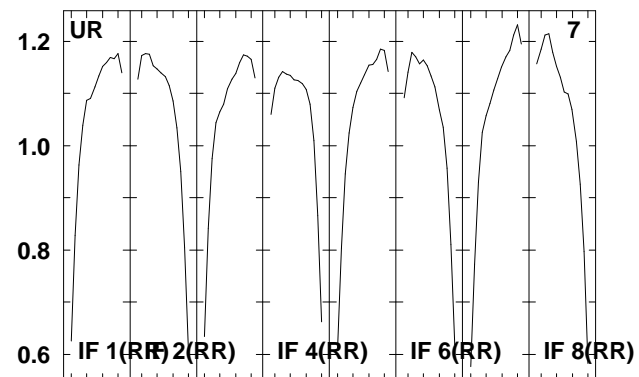
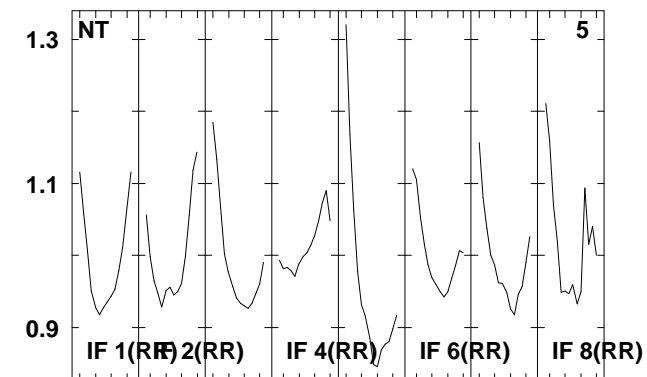
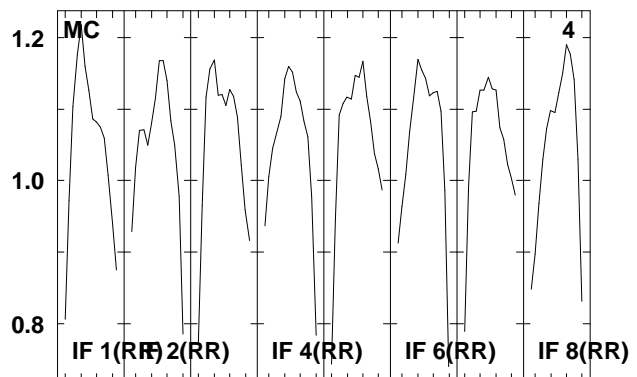
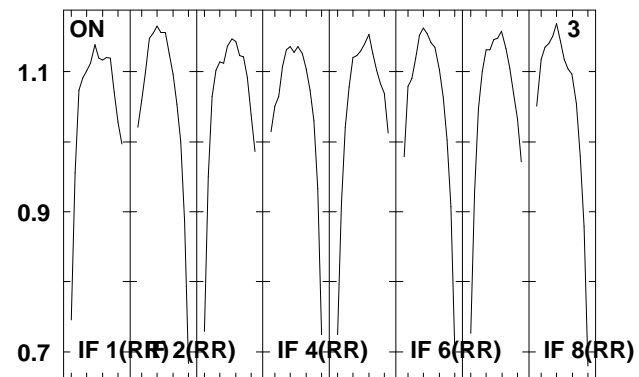
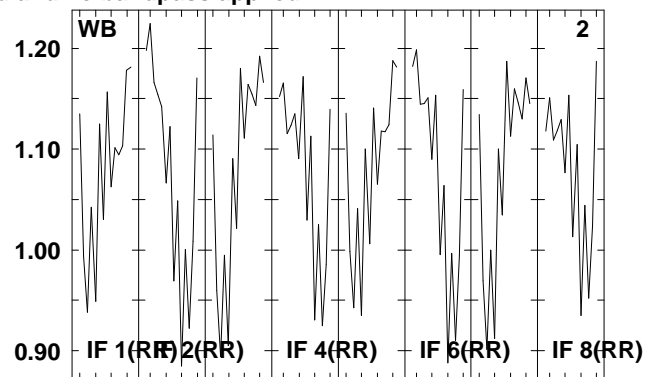
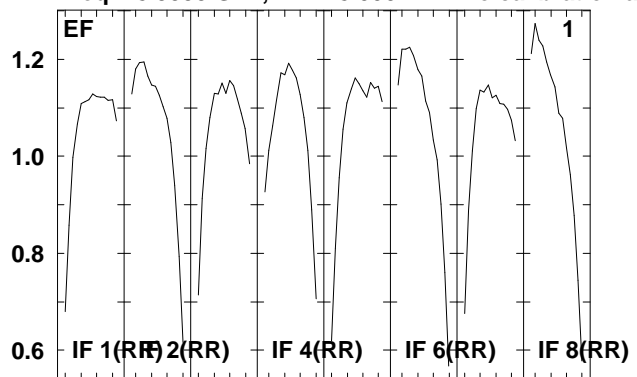

Lower frame: Real Jy  
Total-power spectrum Antenna: \*  
Timerange: 00/22:35:16 to 00/22:36:44



Plot file version 113 created 05-OCT-2009 09:28:34

NGC6240 EH023B 2.UVDATA.1

Freq = 8.3535 GHz, Bw = 8.000 MH No calibration applied and no bandpass applied

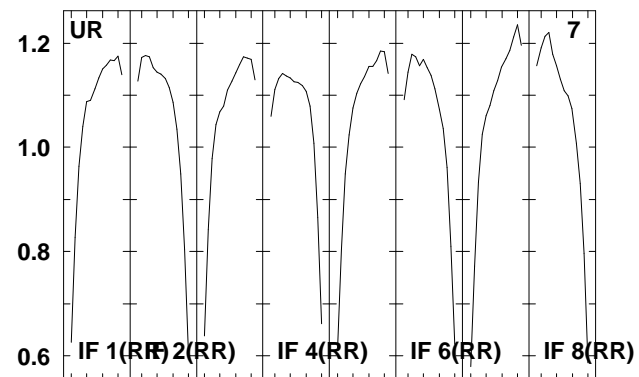
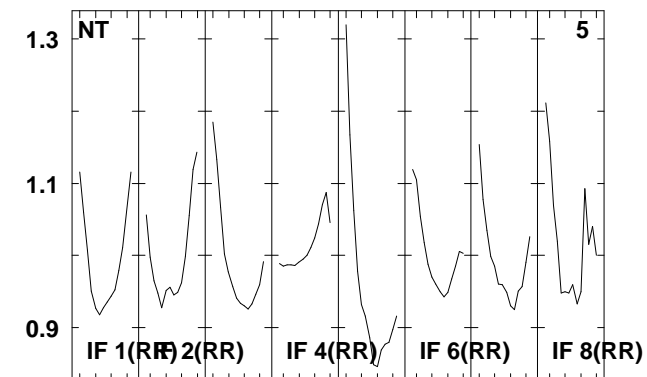
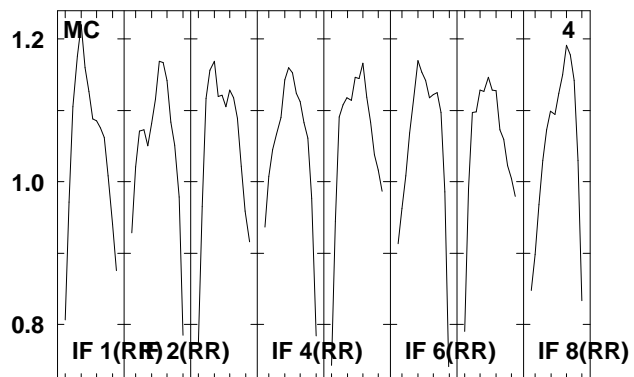
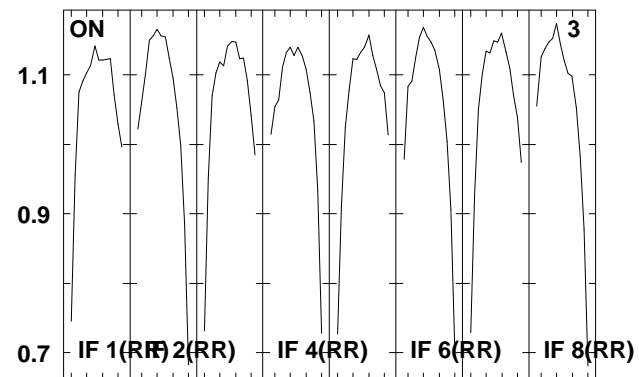
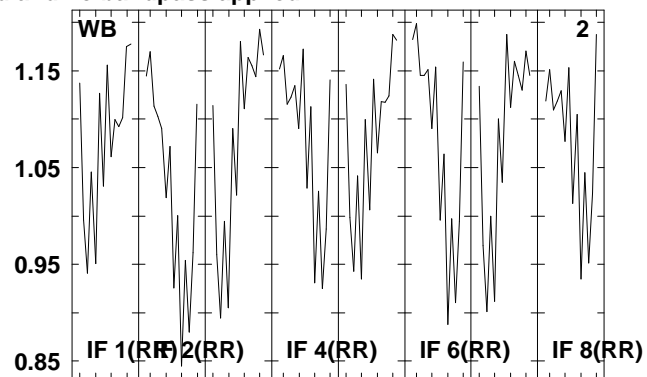
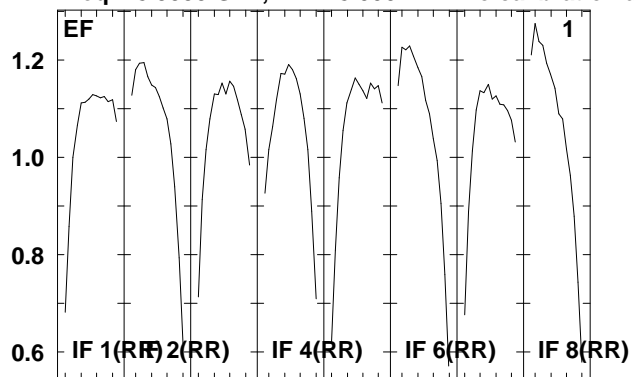

Lower frame: Real Jy  
Total-power spectrum Antenna: \*  
Timerange: 00/22:36:46 to 00/22:40:14

Plot file version 114 created 05-OCT-2009 09:28:35

J1651+01 EH023B 2.UVDATA.1

Freq = 8.3535 GHz, Bw = 8.000 MH No calibration applied and no bandpass applied

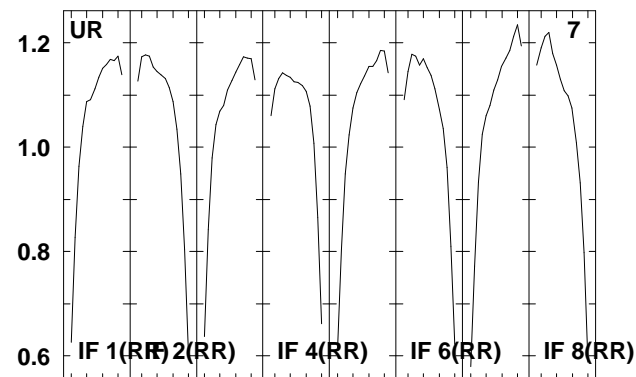
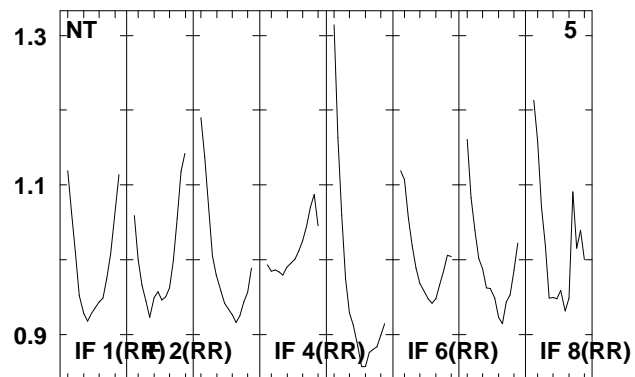
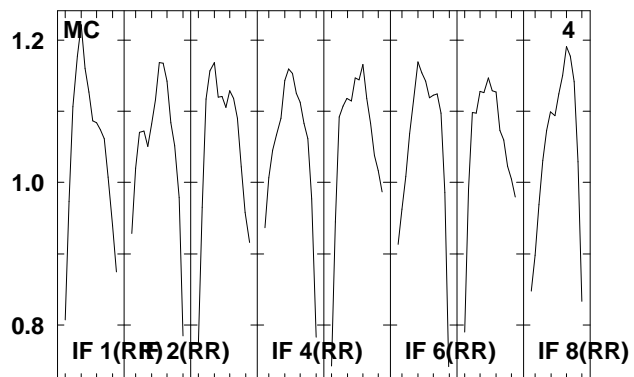
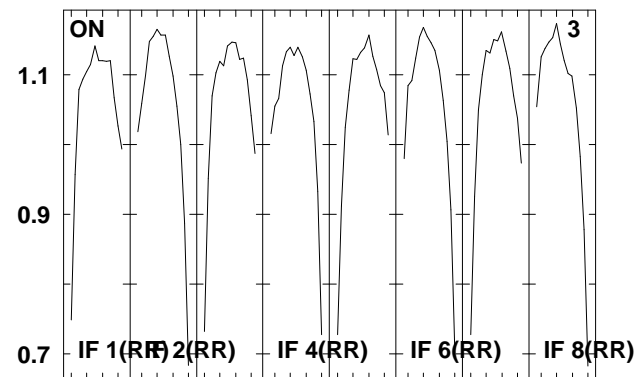
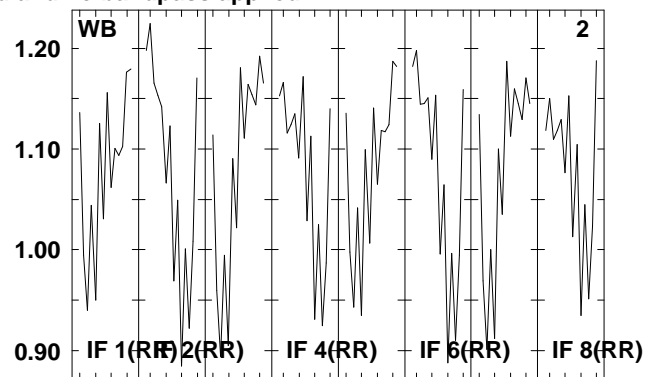
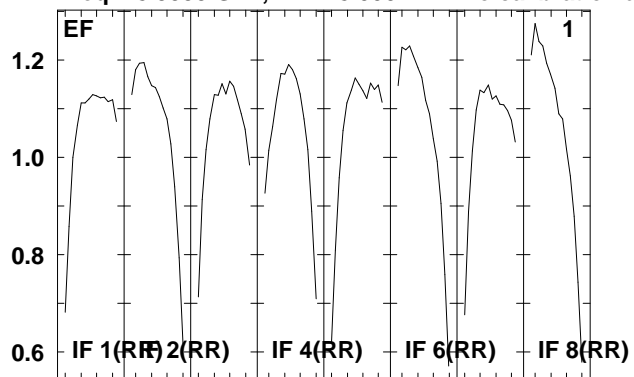

Lower frame: Real Jy  
Total-power spectrum Antenna: \*  
Timerange: 00/22:40:16 to 00/22:41:44

Plot file version 115 created 05-OCT-2009 09:28:35

NGC6240 EH023B 2.UVDATA.1

Freq = 8.3535 GHz, Bw = 8.000 MH No calibration applied and no bandpass applied

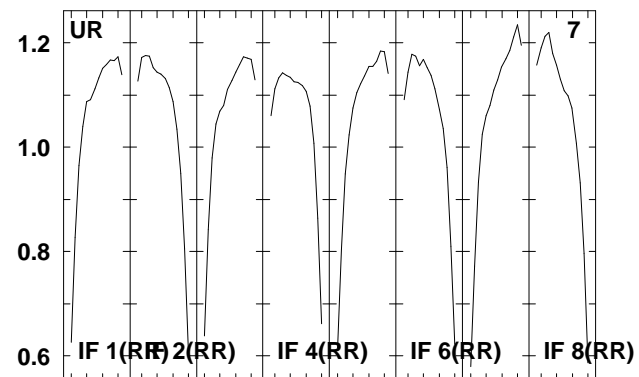
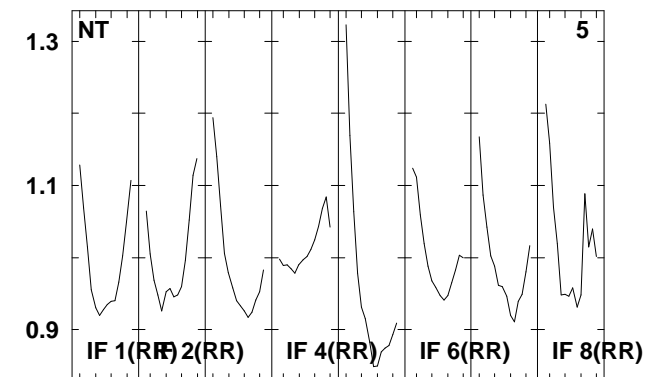
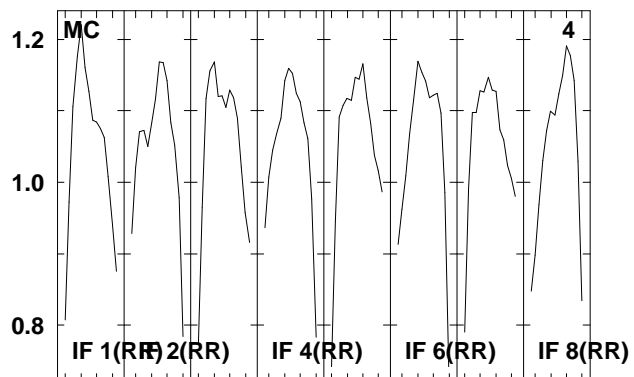
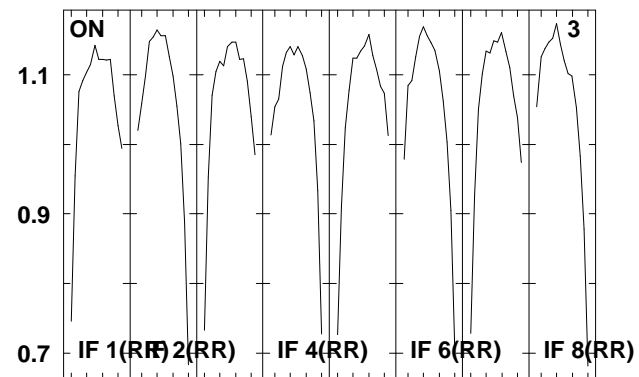
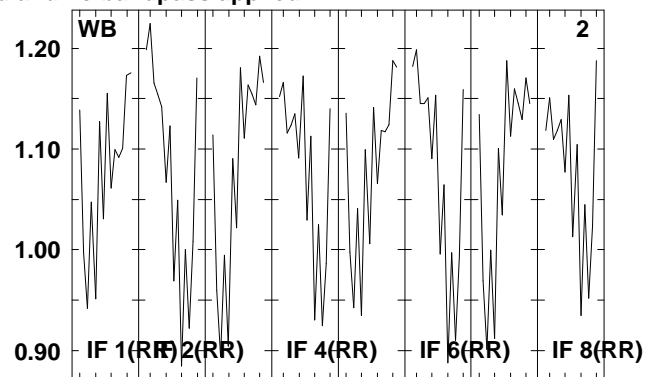
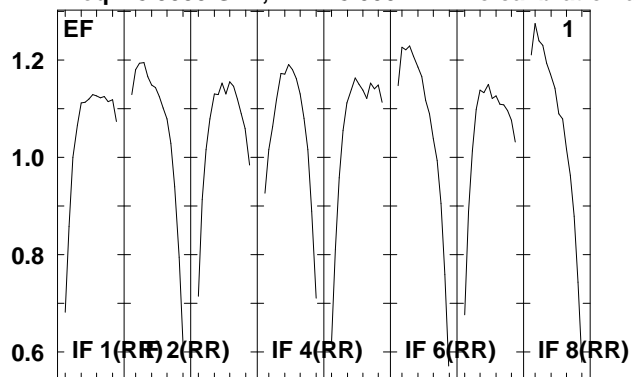

Lower frame: Real Jy  
Total-power spectrum Antenna: \*  
Timerange: 00/22:41:46 to 00/22:45:14

Plot file version 116 created 05-OCT-2009 09:28:35

J1651+01 EH023B 2.UVDATA.1

Freq = 8.3535 GHz, Bw = 8.000 MH No calibration applied and no bandpass applied

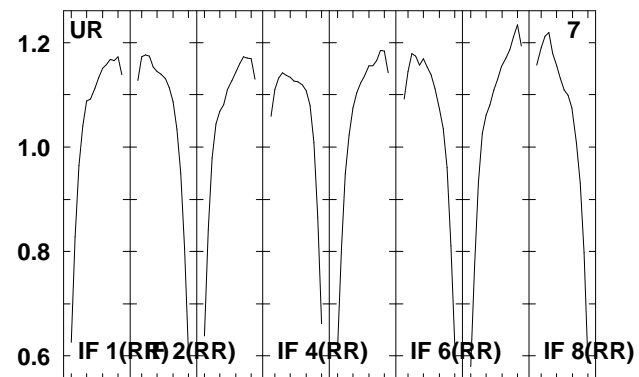
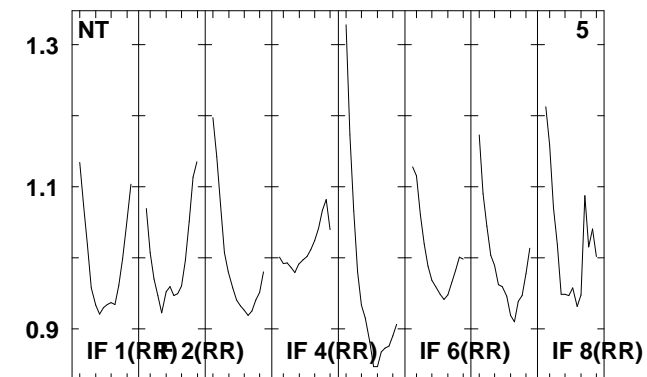
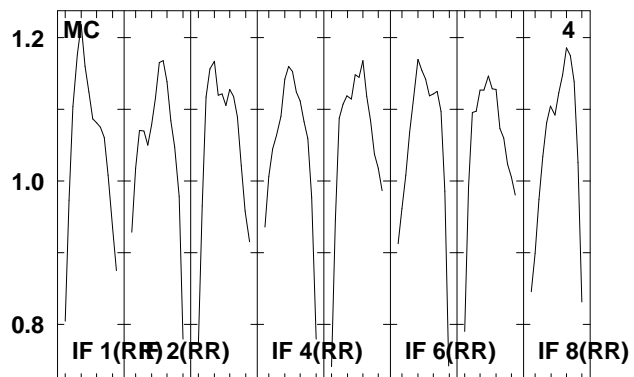
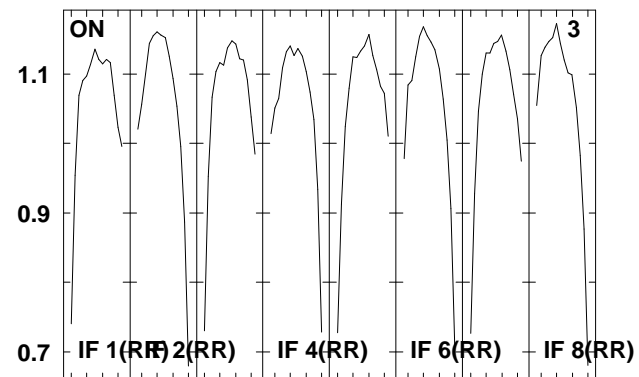
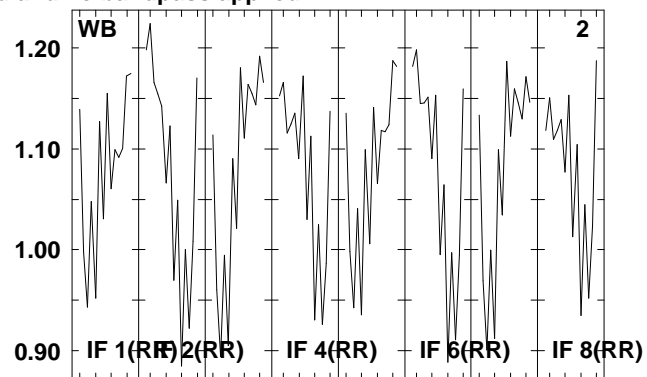
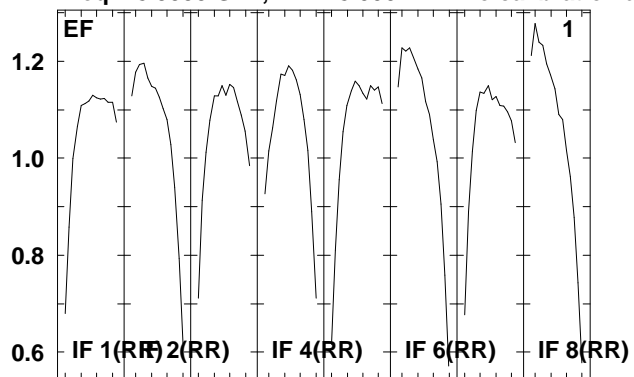

Lower frame: Real Jy  
Total-power spectrum Antenna: \*  
Timerange: 00/22:45:46 to 00/22:47:14

Plot file version 117 created 05-OCT-2009 09:28:35

NGC6240 EH023B 2.UVDATA.1

Freq = 8.3535 GHz, Bw = 8.000 MH No calibration applied and no bandpass applied

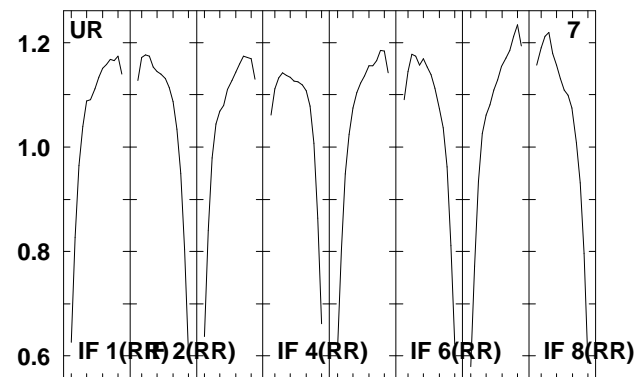
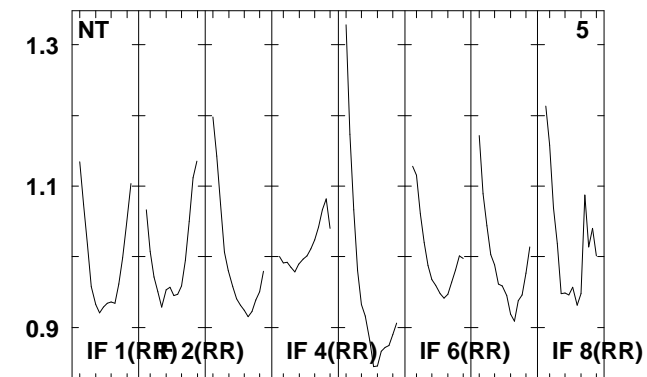
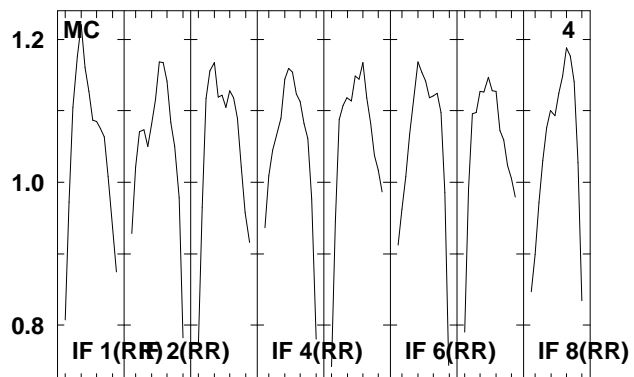
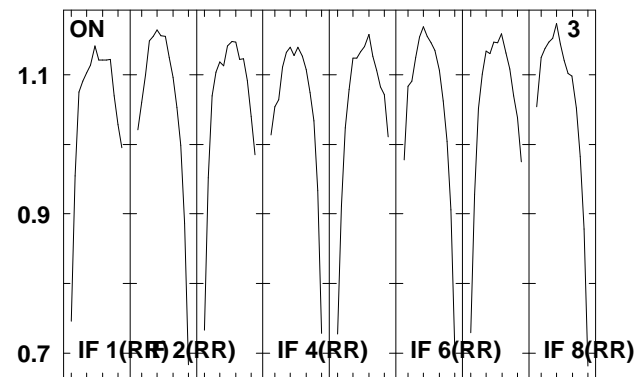
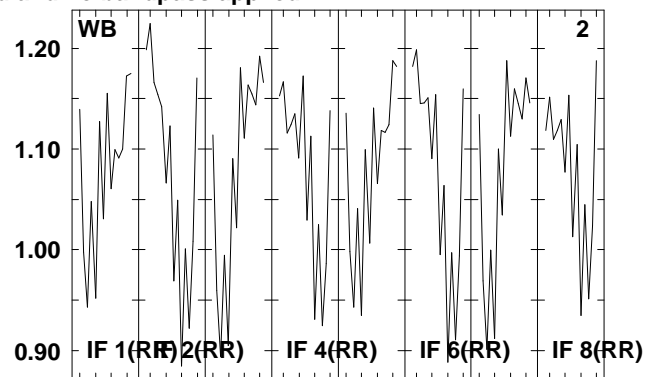
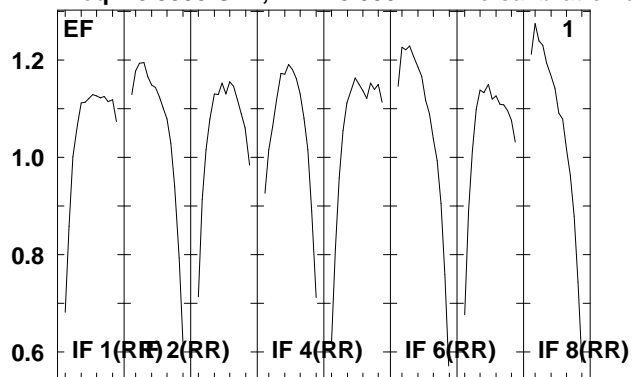

Lower frame: Real Jy  
Total-power spectrum Antenna: \*  
Timerange: 00/22:47:16 to 00/22:50:44

Plot file version 118 created 05-OCT-2009 09:28:35

J1651+01 EH023B 2.UVDATA.1

Freq = 8.3535 GHz, Bw = 8.000 MH No calibration applied and no bandpass applied

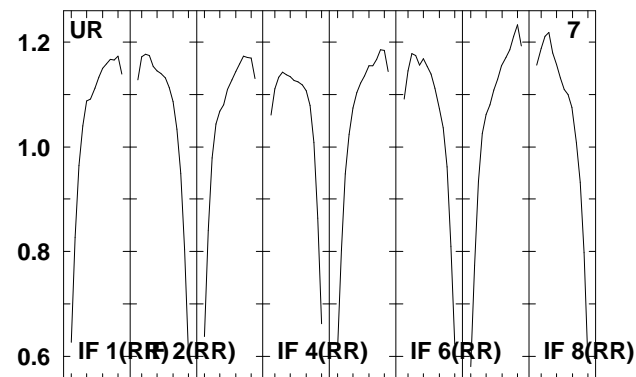
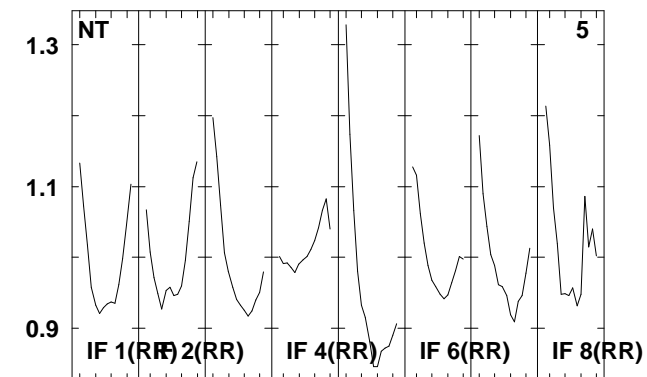
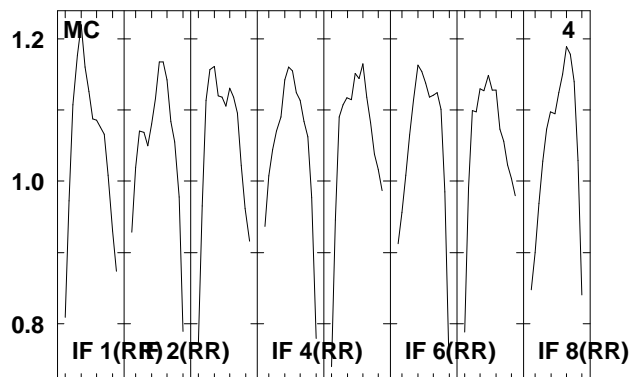
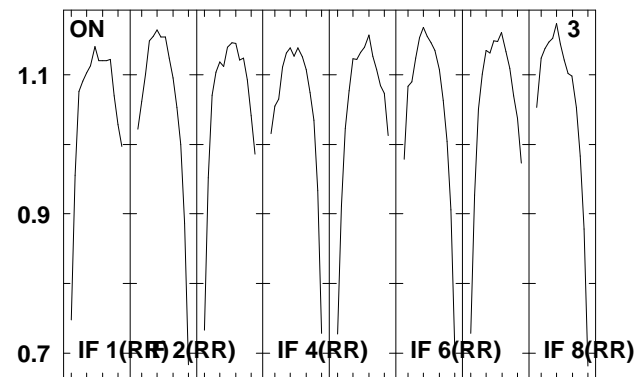
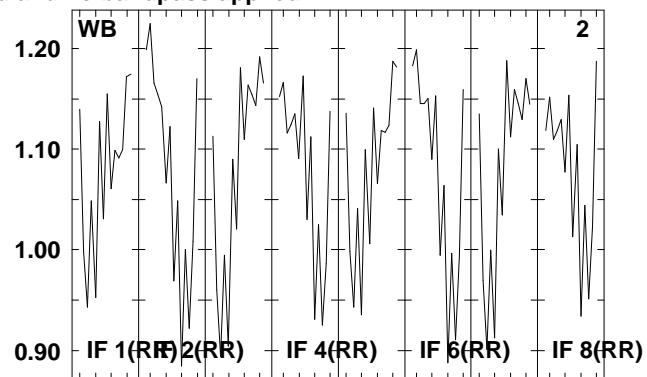
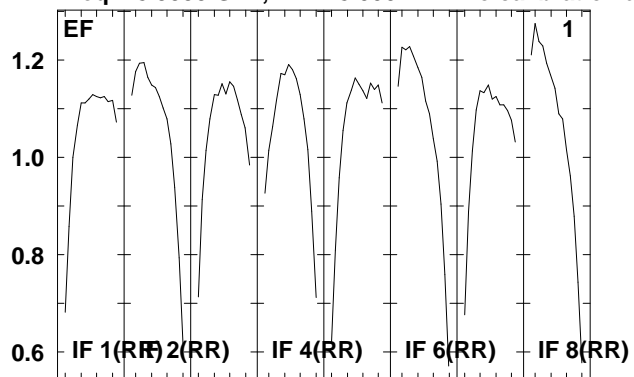

Lower frame: Real Jy  
Total-power spectrum Antenna: \*  
Timerange: 00/22:50:46 to 00/22:52:14

Plot file version 119 created 05-OCT-2009 09:28:35

NGC6240 EH023B 2.UVDATA.1

Freq = 8.3535 GHz, Bw = 8.000 MH No calibration applied and no bandpass applied

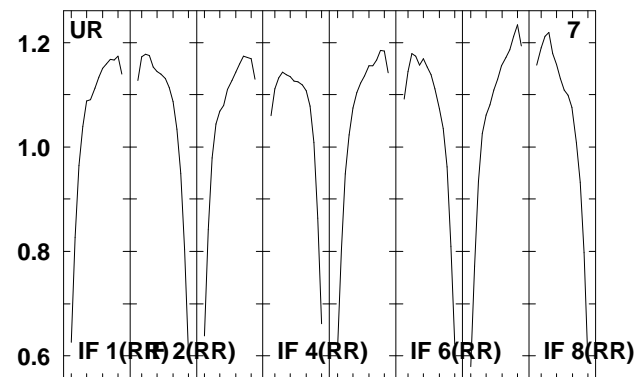
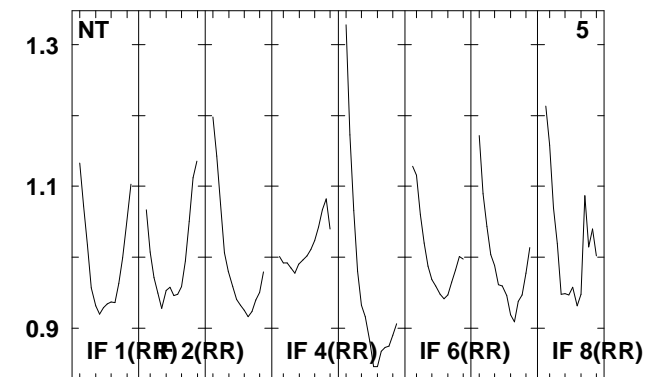
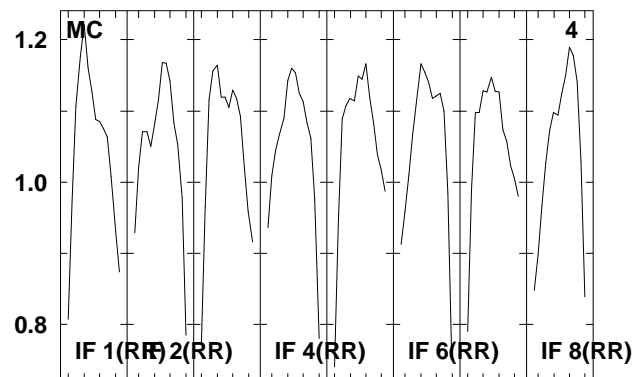
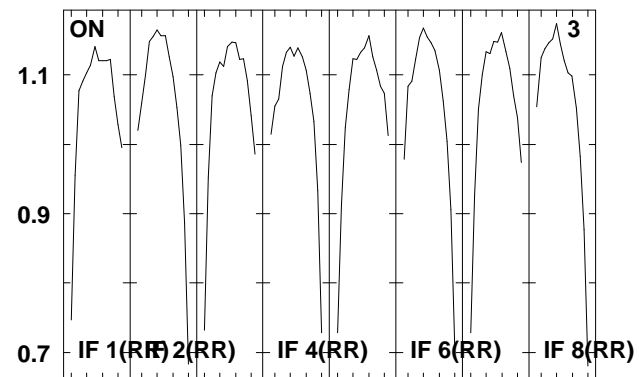
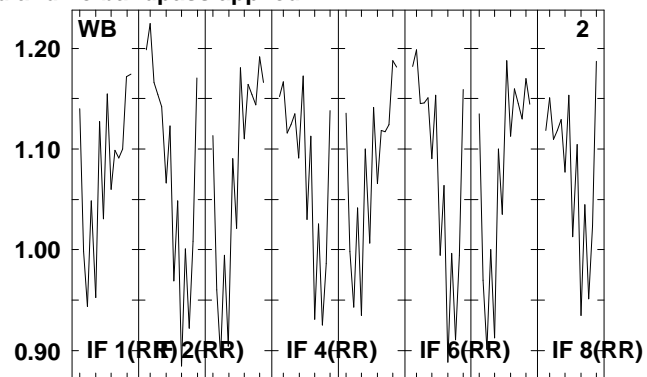
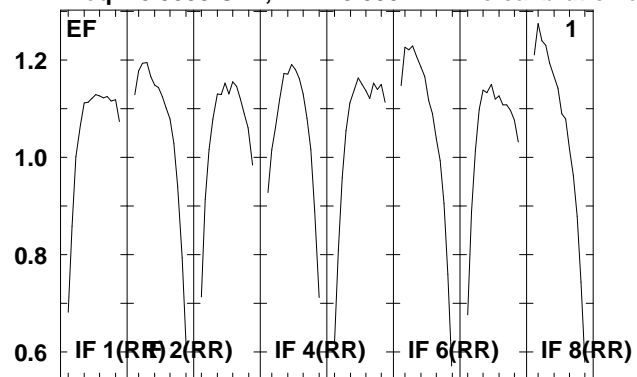

Lower frame: Real Jy  
Total-power spectrum Antenna: \*  
Timerange: 00/22:52:16 to 00/22:55:44

Plot file version 120 created 05-OCT-2009 09:28:36

J1651+01 EH023B 2.UVDATA.1

Freq = 8.3535 GHz, Bw = 8.000 MH No calibration applied and no bandpass applied

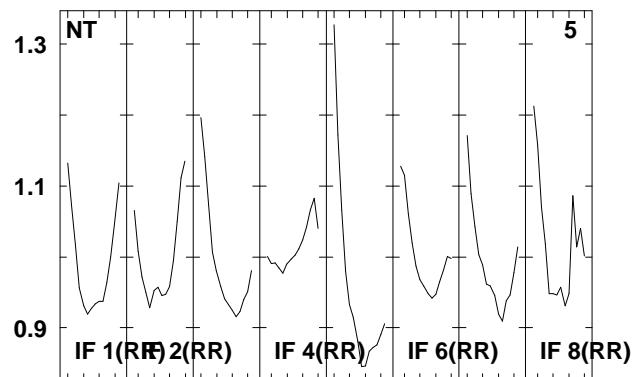
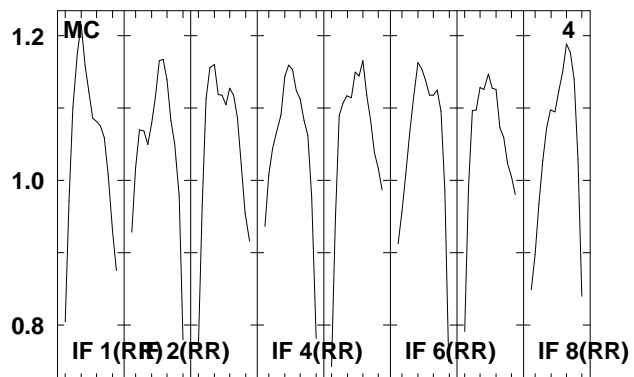
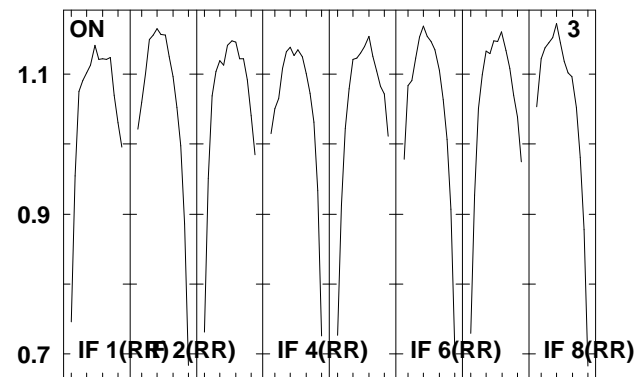
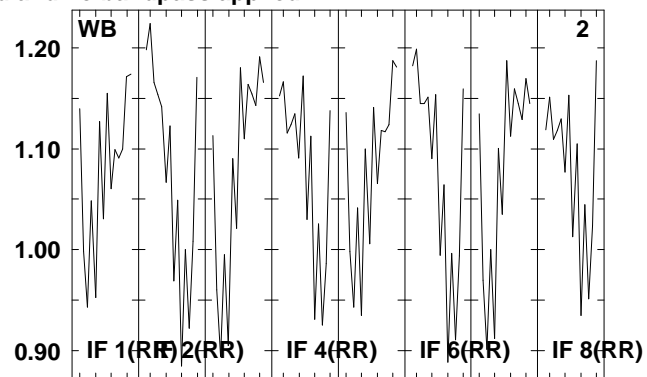
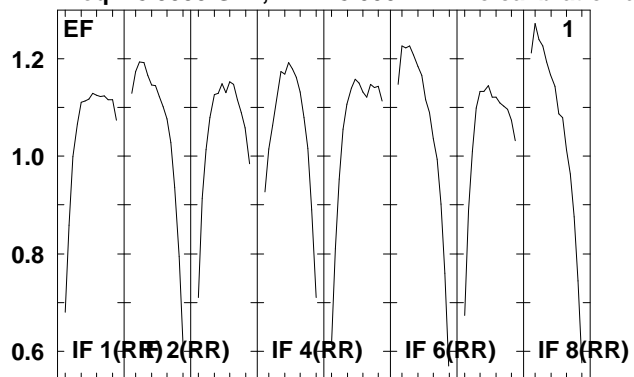

Lower frame: Real Jy  
Total-power spectrum Antenna: \*  
Timerange: 00/22:56:16 to 00/22:57:44



Plot file version 121 created 05-OCT-2009 09:28:36

NGC6240 EH023B 2.UVDATA.1

Freq = 8.3535 GHz, Bw = 8.000 MH No calibration applied and no bandpass applied

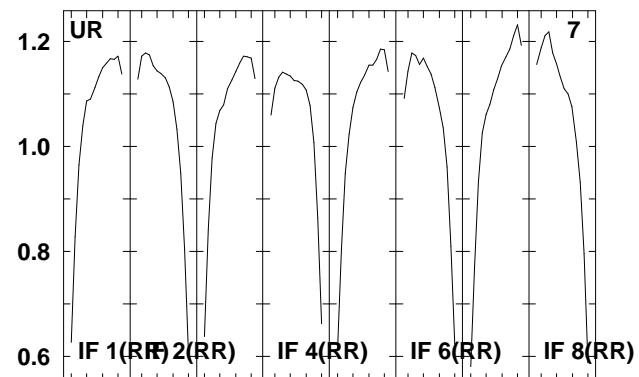
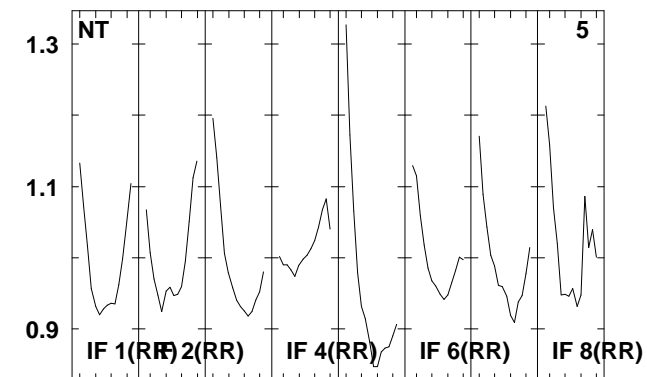
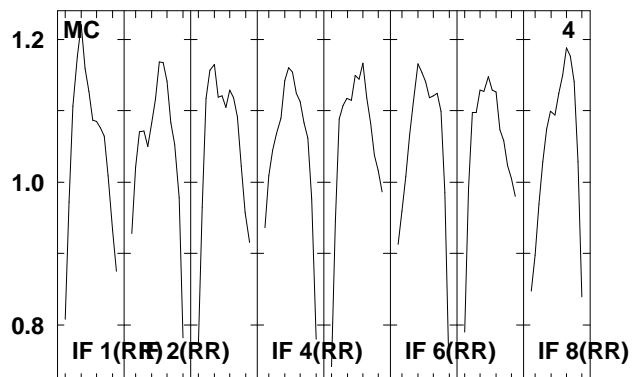
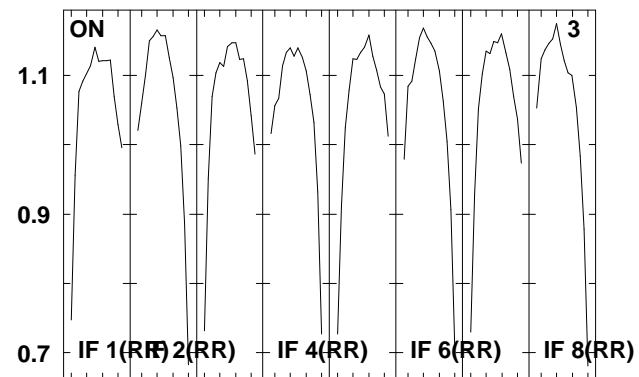
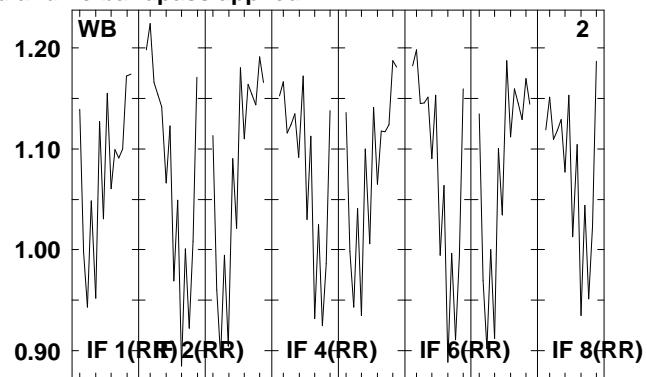
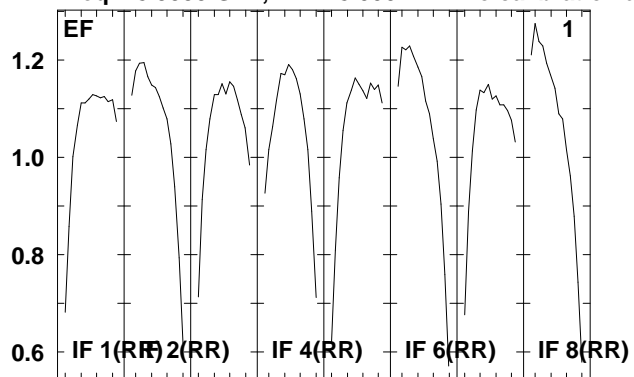

Lower frame: Real Jy  
Total-power spectrum Antenna: \*  
Timerange: 00/22:57:46 to 00/23:01:14

Plot file version 122 created 05-OCT-2009 09:28:36

J1651+01 EH023B 2.UVDATA.1

Freq = 8.3535 GHz, Bw = 8.000 MH No calibration applied and no bandpass applied

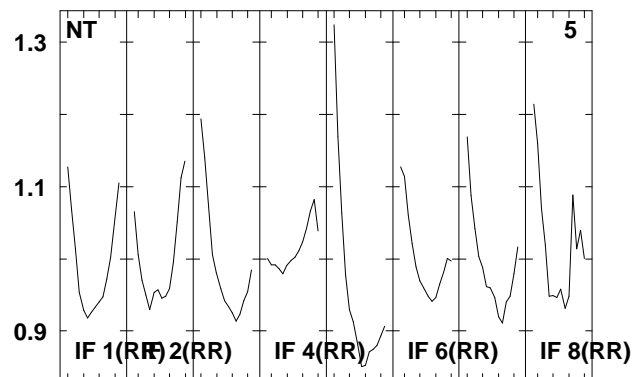
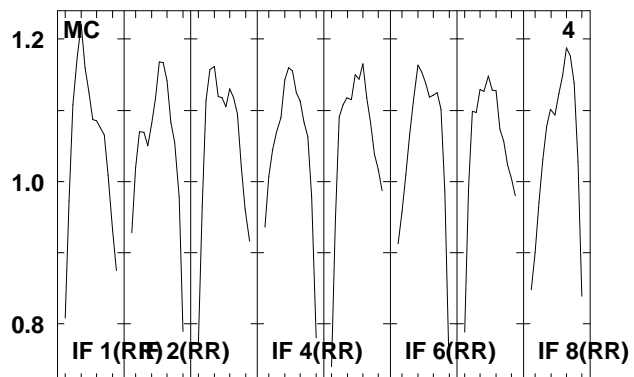
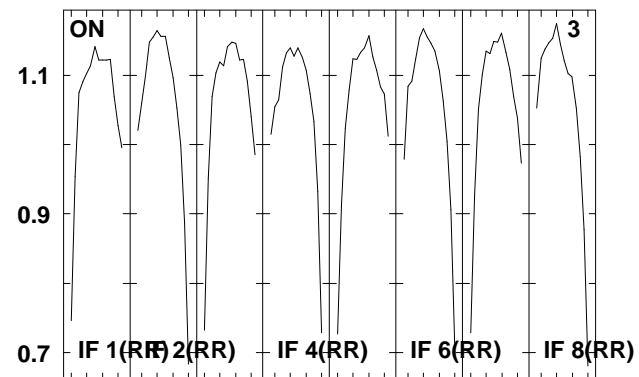
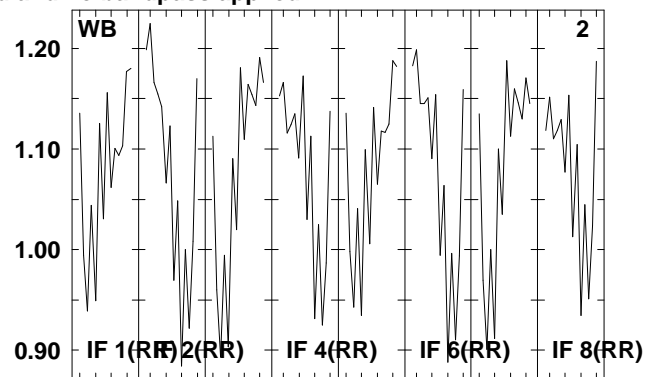
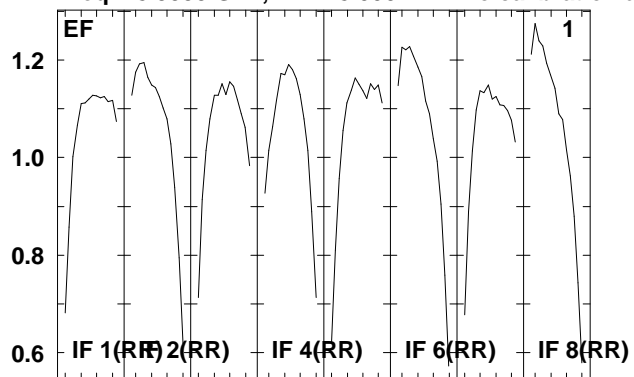

Lower frame: Real Jy  
Total-power spectrum Antenna: \*  
Timerange: 00/23:01:16 to 00/23:02:44

Plot file version 123 created 05-OCT-2009 09:28:36

NGC6240 EH023B 2.UVDATA.1

Freq = 8.3535 GHz, Bw = 8.000 MH No calibration applied and no bandpass applied

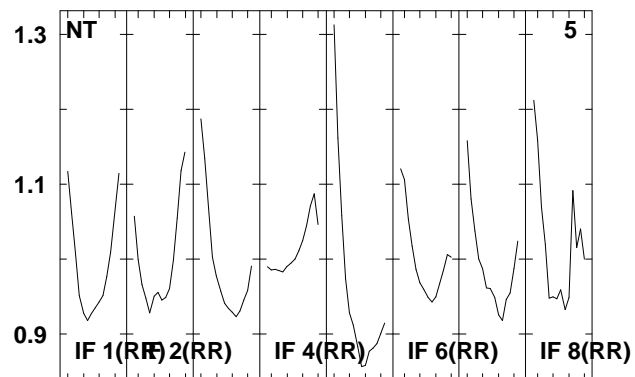
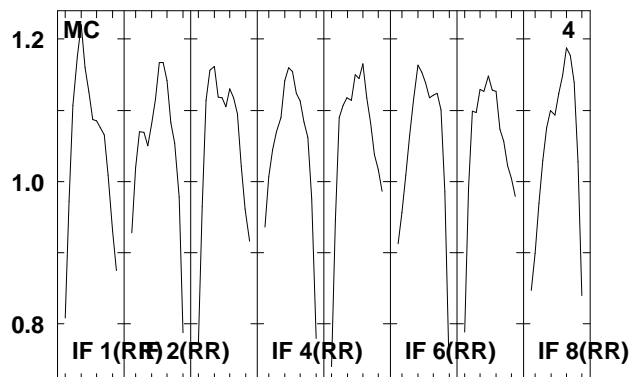
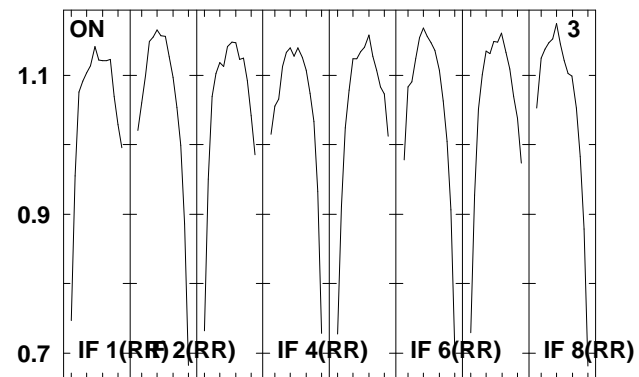
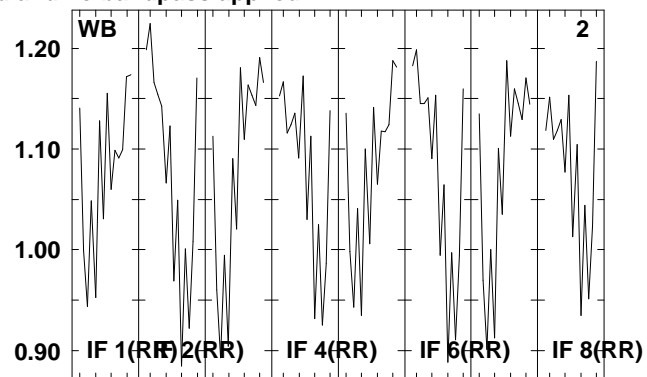
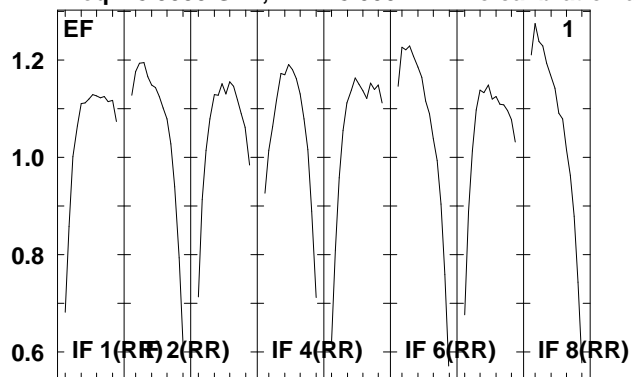

Lower frame: Real Jy  
Total-power spectrum Antenna: \*  
Timerange: 00/23:02:46 to 00/23:06:14

Plot file version 124 created 05-OCT-2009 09:28:36

J1651+01 EH023B 2.UVDATA.1

Freq = 8.3535 GHz, Bw = 8.000 MH No calibration applied and no bandpass applied

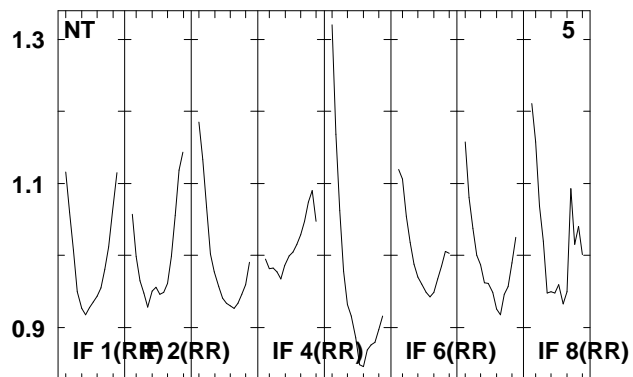
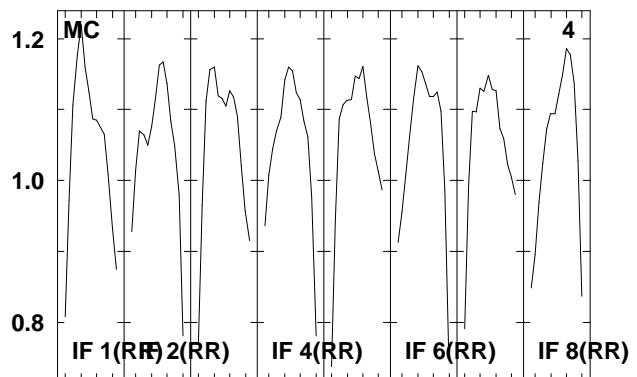
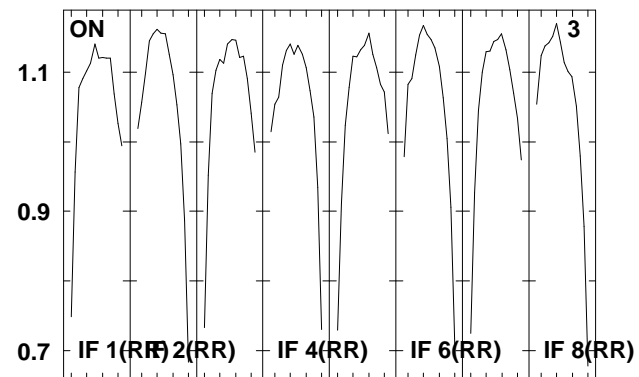
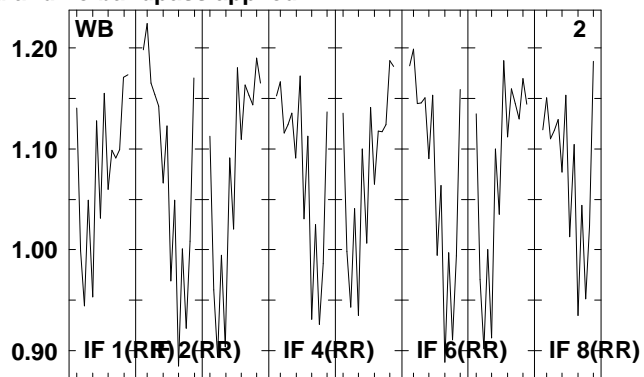
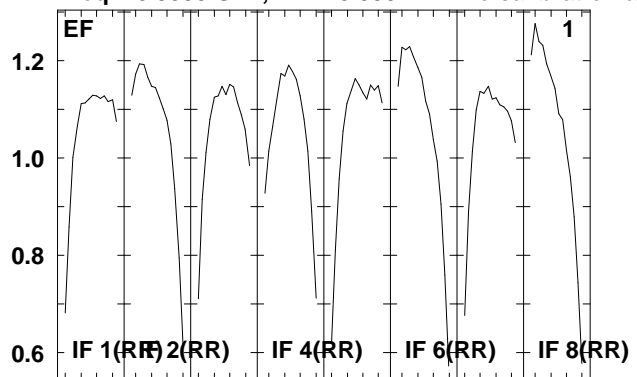

Lower frame: Real Jy  
Total-power spectrum Antenna: \*  
Timerange: 00/23:06:46 to 00/23:08:14

Plot file version 125 created 05-OCT-2009 09:28:36

NGC6240 EH023B 2.UVDATA.1

Freq = 8.3535 GHz, Bw = 8.000 MH No calibration applied and no bandpass applied

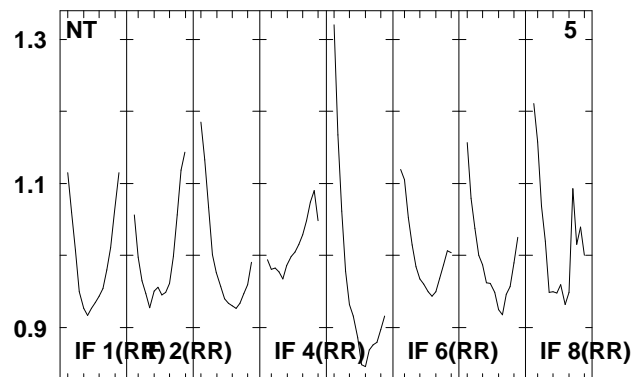
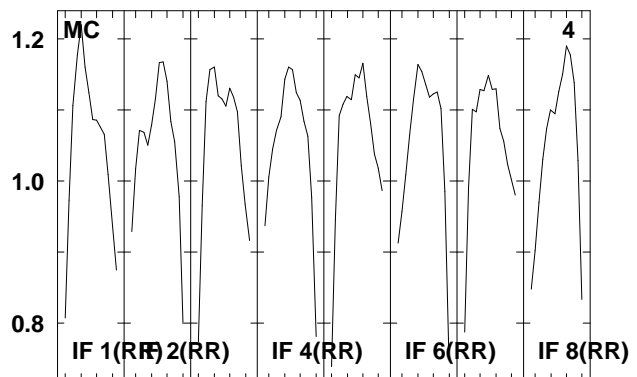
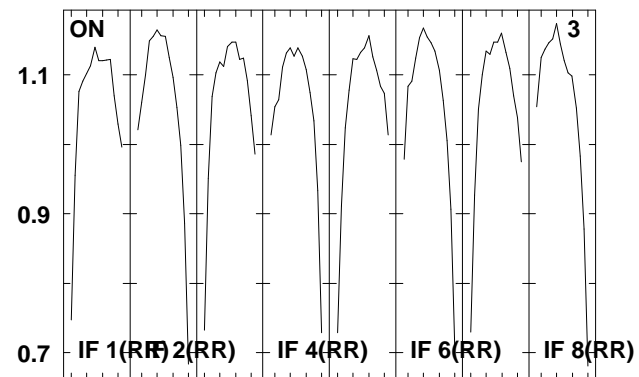
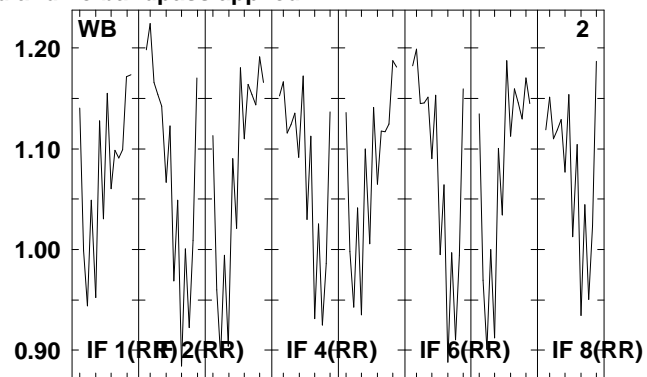
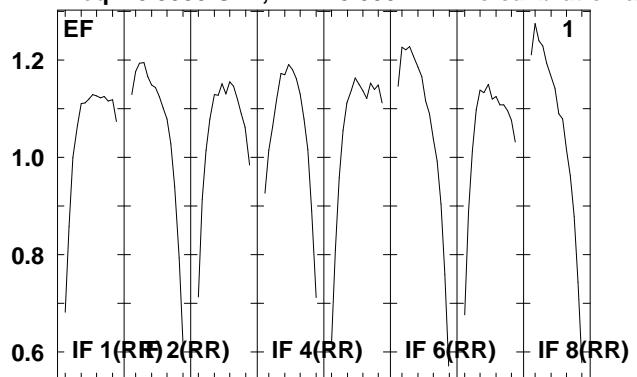

Lower frame: Real Jy  
Total-power spectrum Antenna: \*  
Timerange: 00/23:08:16 to 00/23:11:44

Plot file version 126 created 05-OCT-2009 09:28:36

J1651+01 EH023B 2.UVDATA.1

Freq = 8.3535 GHz, Bw = 8.000 MH No calibration applied and no bandpass applied

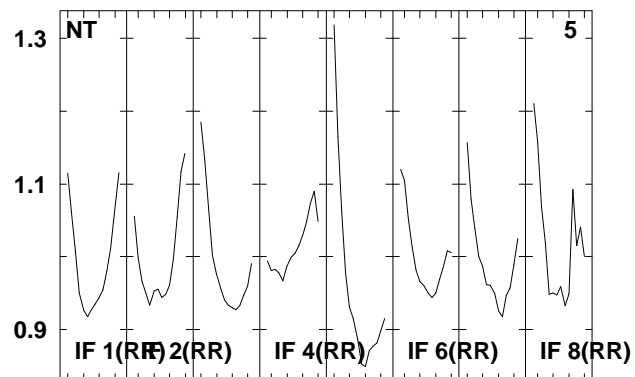
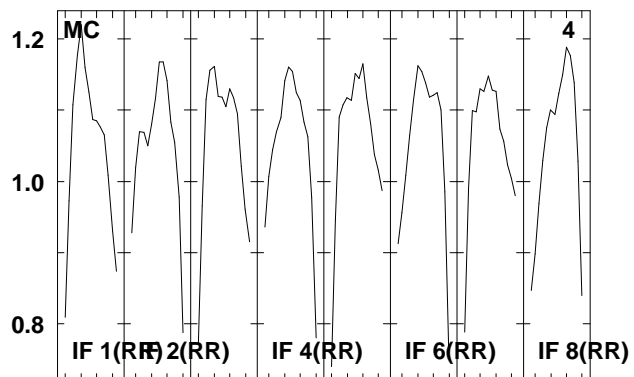
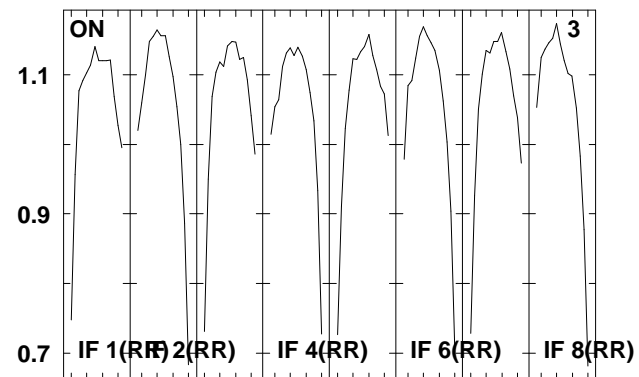
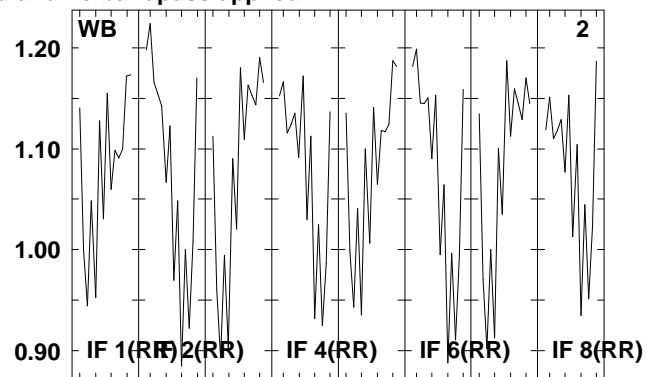
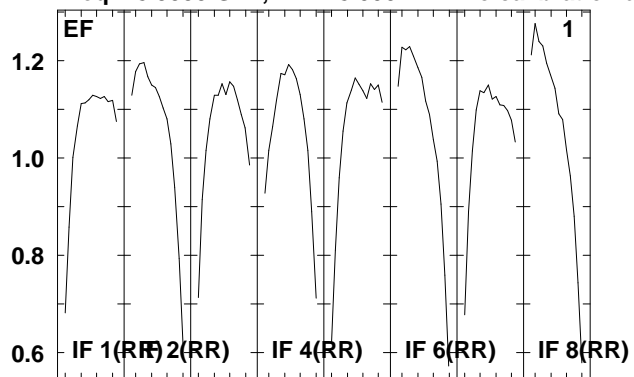

Lower frame: Real Jy  
Total-power spectrum Antenna: \*  
Timerange: 00/23:11:46 to 00/23:13:14

Plot file version 127 created 05-OCT-2009 09:28:37

NGC6240 EH023B 2.UVDATA.1

Freq = 8.3535 GHz, Bw = 8.000 MH No calibration applied and no bandpass applied

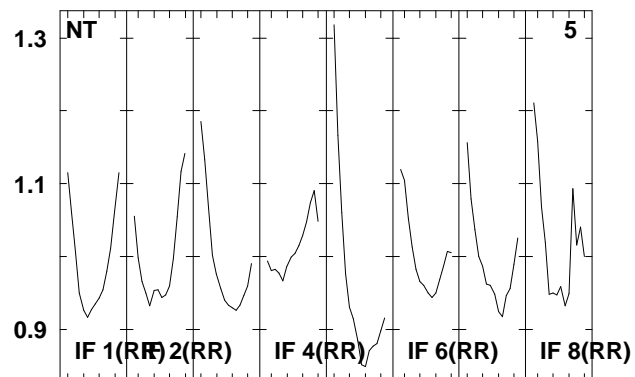
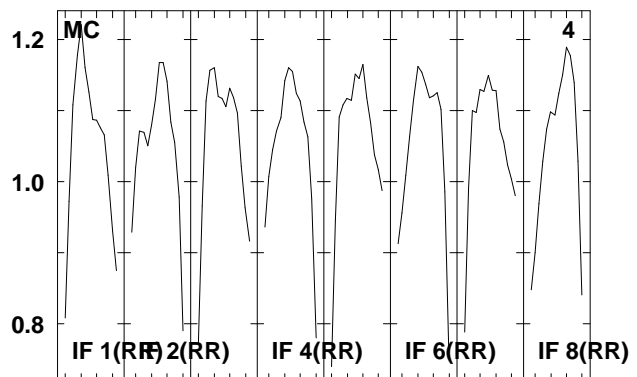
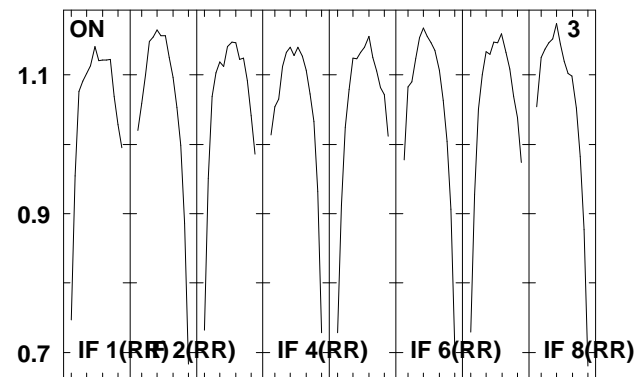
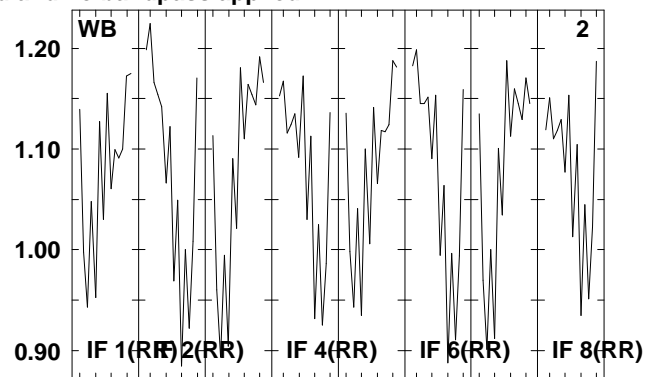
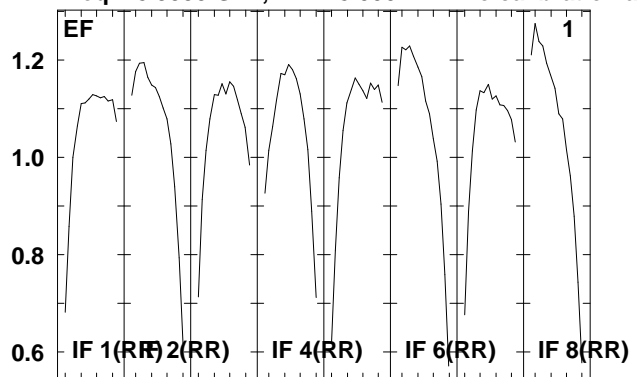

Lower frame: Real Jy  
Total-power spectrum Antenna: \*  
Timerange: 00/23:13:16 to 00/23:16:44

Plot file version 128 created 05-OCT-2009 09:28:37

J1651+01 EH023B 2.UVDATA.1

Freq = 8.3535 GHz, Bw = 8.000 MH No calibration applied and no bandpass applied

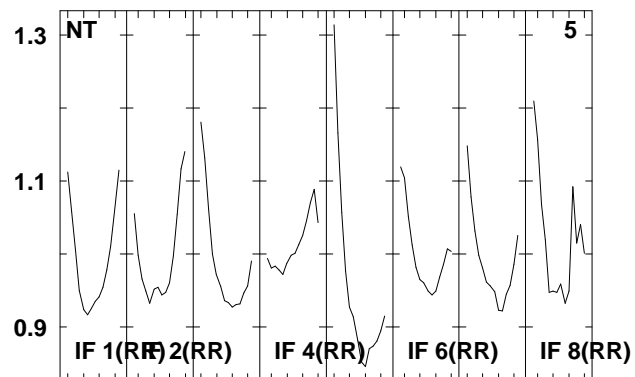
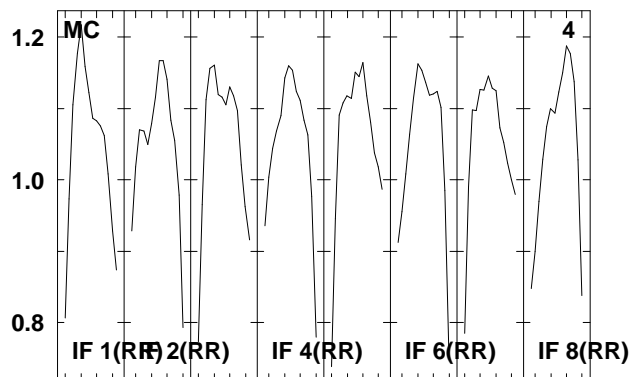
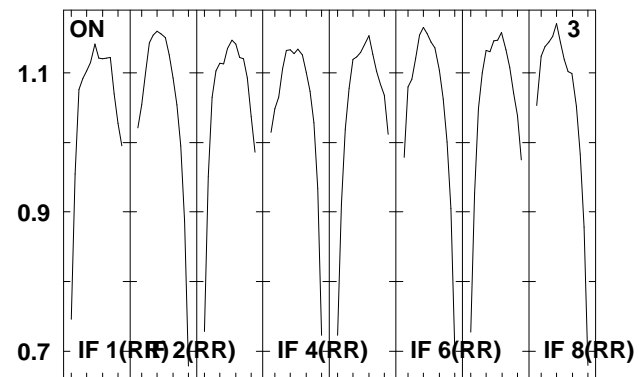
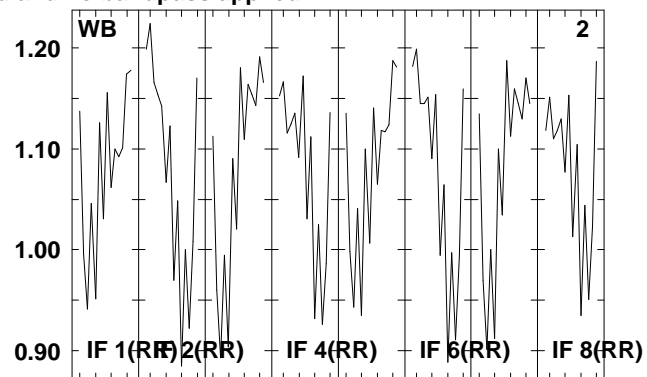
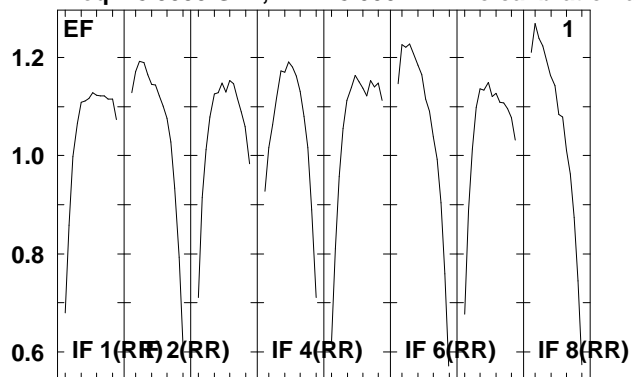

Lower frame: Real Jy  
Total-power spectrum Antenna: \*  
Timerange: 00/23:17:16 to 00/23:18:44



Plot file version 129 created 05-OCT-2009 09:28:37

NGC6240 EH023B 2.UVDATA.1

Freq = 8.3535 GHz, Bw = 8.000 MH No calibration applied and no bandpass applied

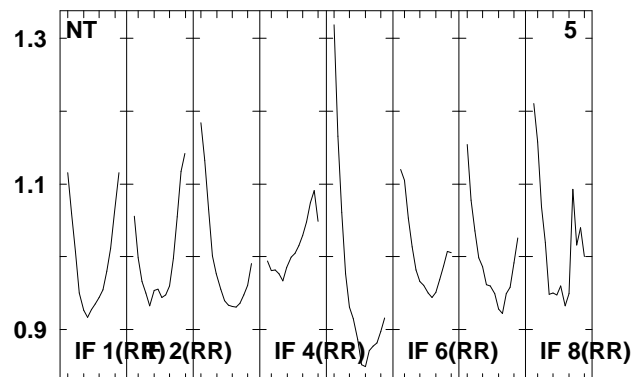
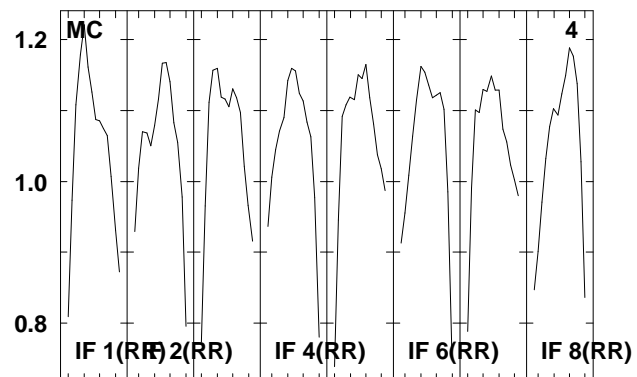
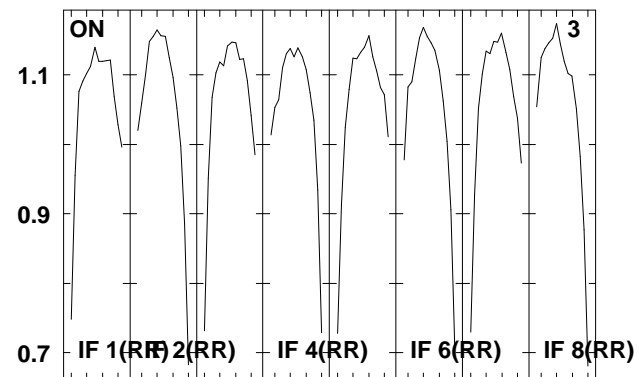
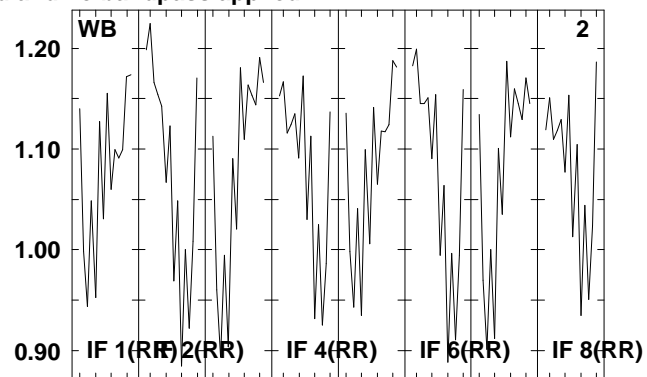
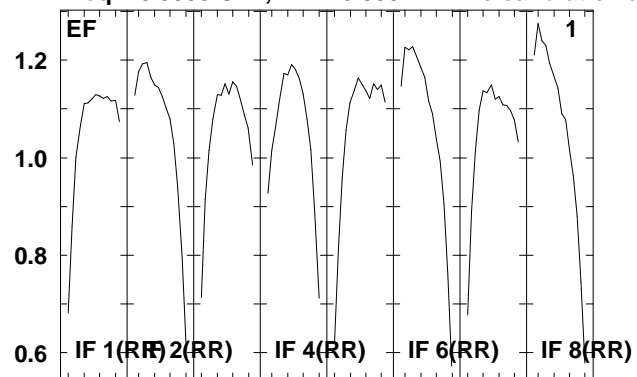

Lower frame: Real Jy  
Total-power spectrum Antenna: \*  
Timerange: 00/23:18:46 to 00/23:22:14

Plot file version 130 created 05-OCT-2009 09:28:37

J1651+01 EH023B 2.UVDATA.1

Freq = 8.3535 GHz, Bw = 8.000 MH No calibration applied and no bandpass applied

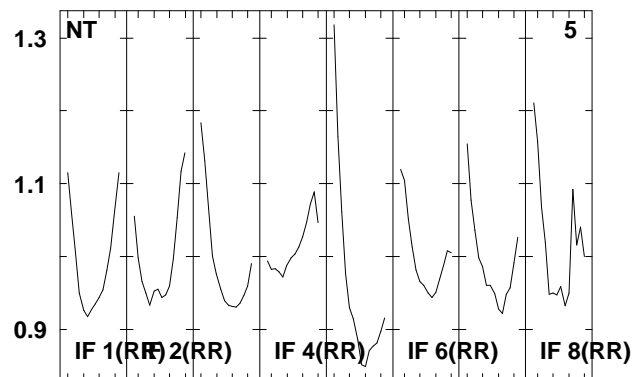
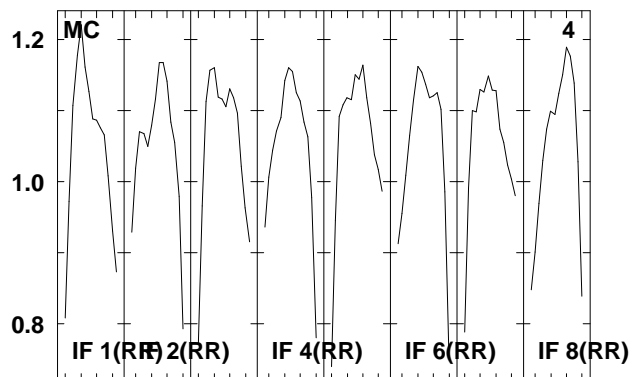
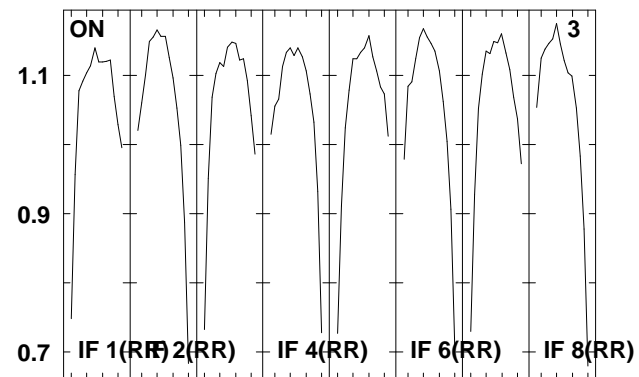
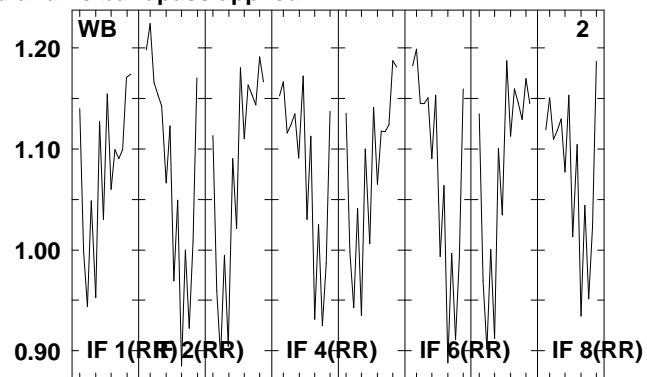
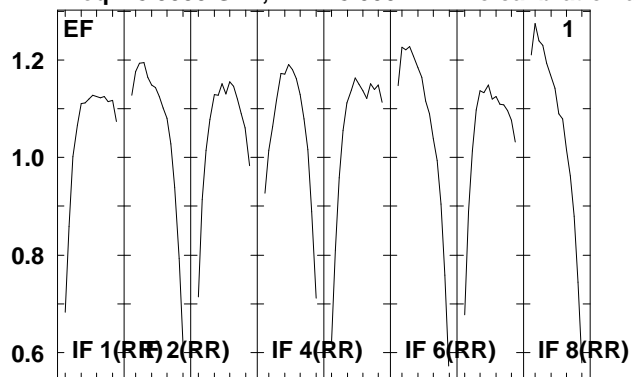

Lower frame: Real Jy  
Total-power spectrum Antenna: \*  
Timerange: 00/23:22:16 to 00/23:23:44

Plot file version 131 created 05-OCT-2009 09:28:37

NGC6240 EH023B 2.UVDATA.1

Freq = 8.3535 GHz, Bw = 8.000 MH No calibration applied and no bandpass applied

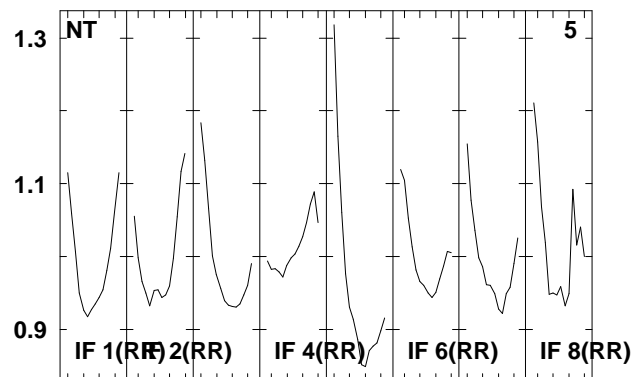
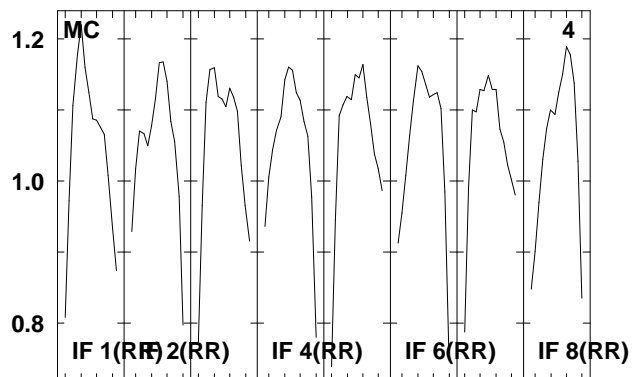
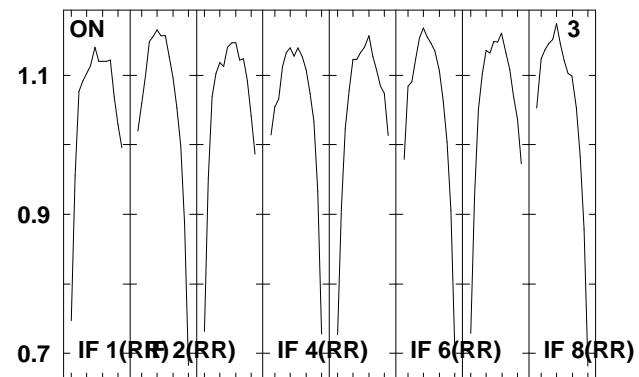
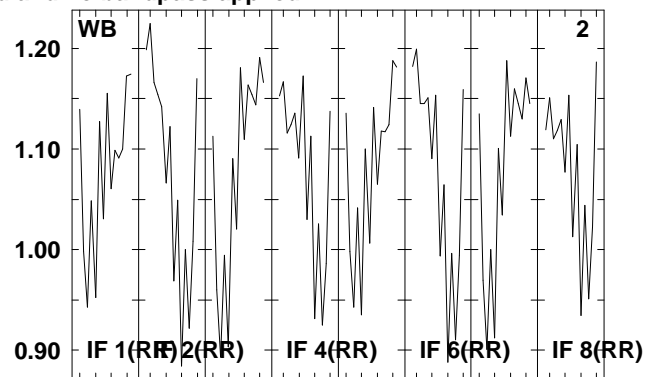
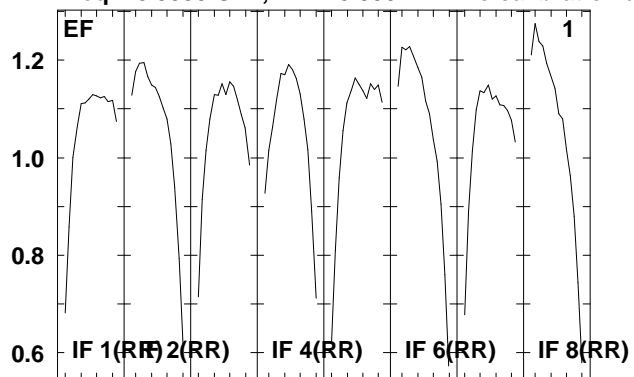

Lower frame: Real Jy  
Total-power spectrum Antenna: \*  
Timerange: 00/23:23:46 to 00/23:27:14

Plot file version 132 created 05-OCT-2009 09:28:37

J1651+01 EH023B 2.UVDATA.1

Freq = 8.3535 GHz, Bw = 8.000 MH No calibration applied and no bandpass applied

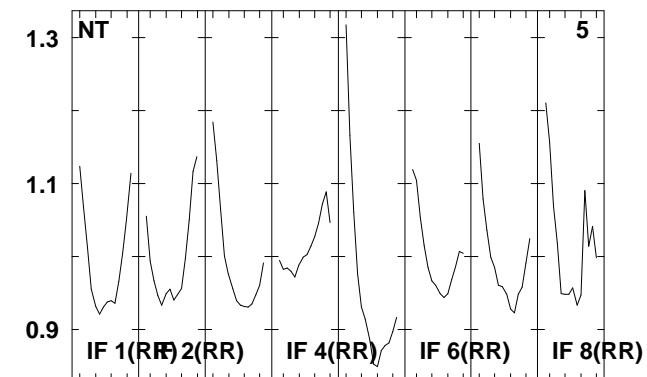
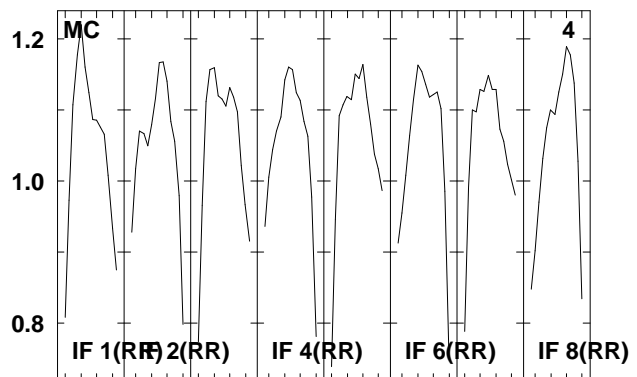
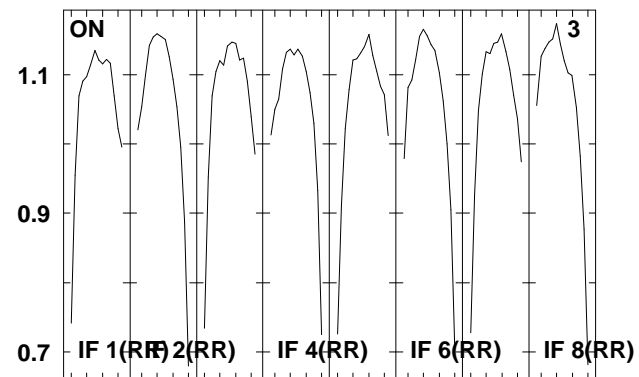
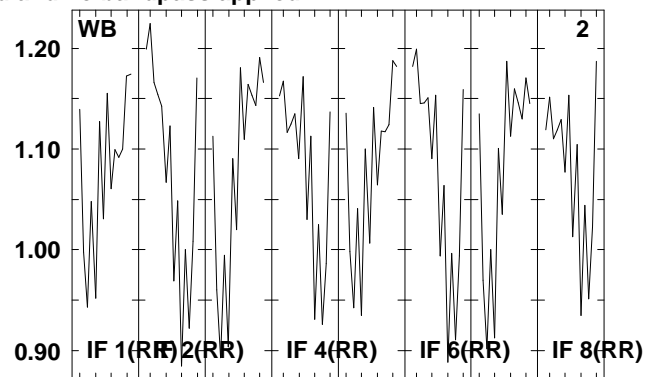
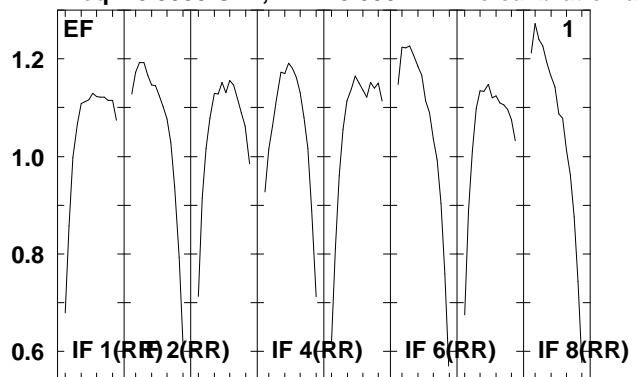

Lower frame: Real Jy  
Total-power spectrum Antenna: \*  
Timerange: 00/23:27:46 to 00/23:29:14

Plot file version 133 created 05-OCT-2009 09:28:37

NGC6240 EH023B 2.UVDATA.1

Freq = 8.3535 GHz, Bw = 8.000 MH No calibration applied and no bandpass applied

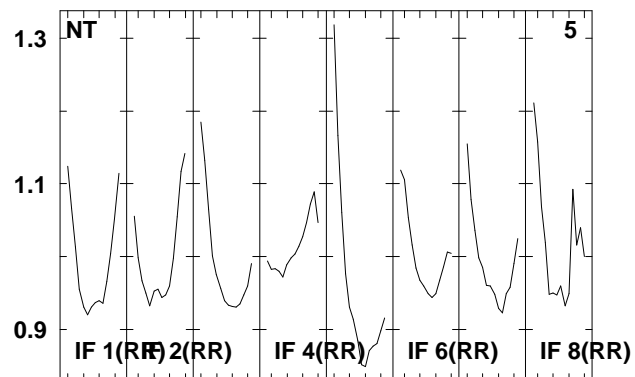
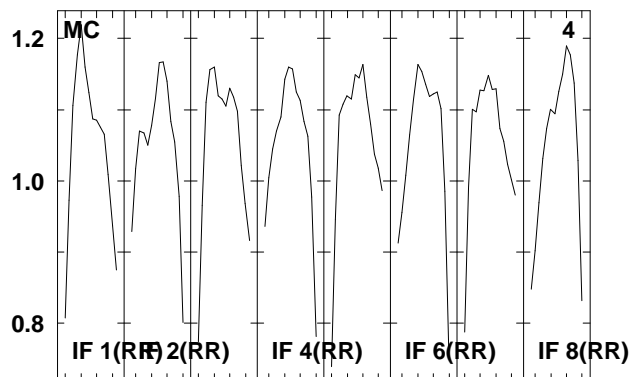
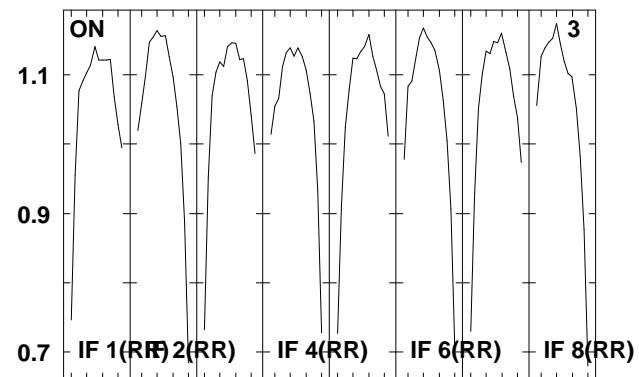
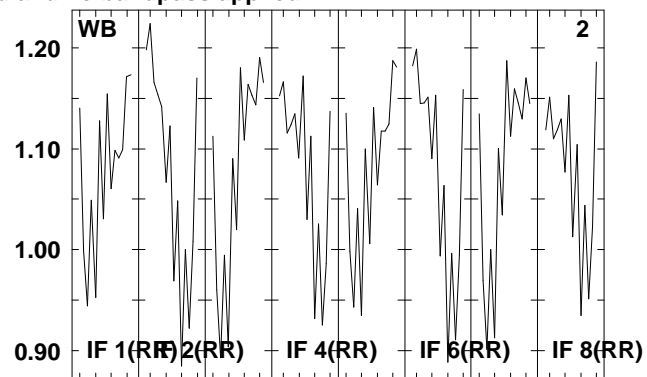
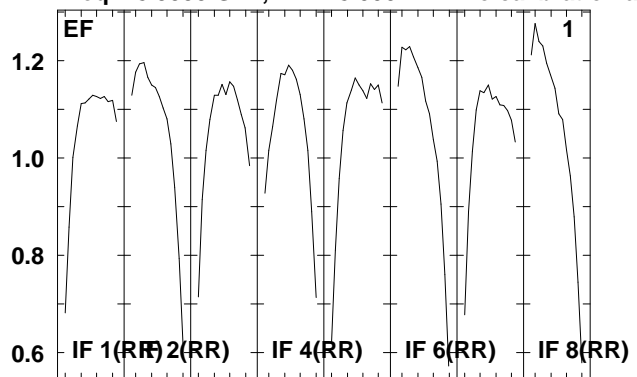

Lower frame: Real Jy  
Total-power spectrum Antenna: \*  
Timerange: 00/23:29:16 to 00/23:32:44

Plot file version 134 created 05-OCT-2009 09:28:37

J1651+01 EH023B 2.UVDATA.1

Freq = 8.3535 GHz, Bw = 8.000 MH No calibration applied and no bandpass applied

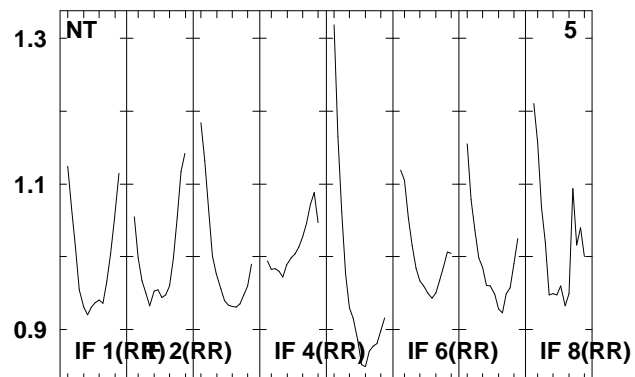
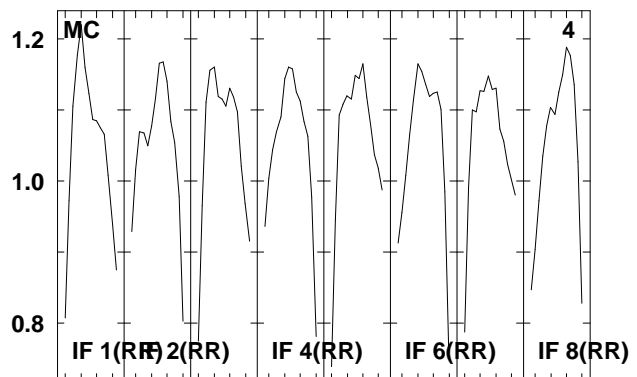
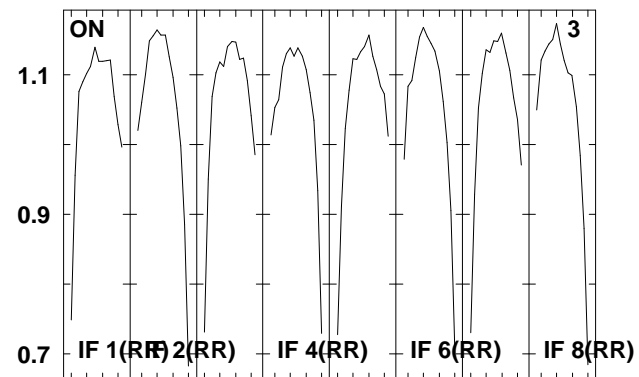
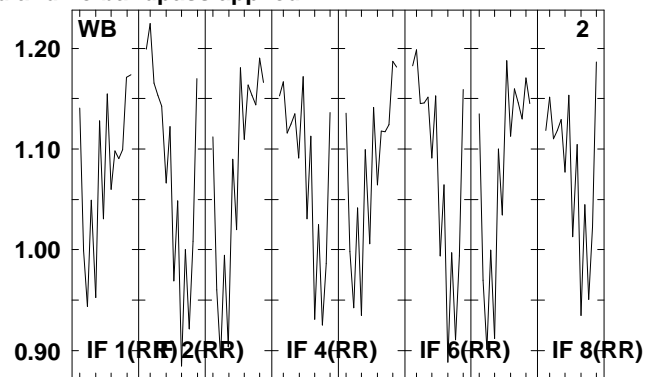
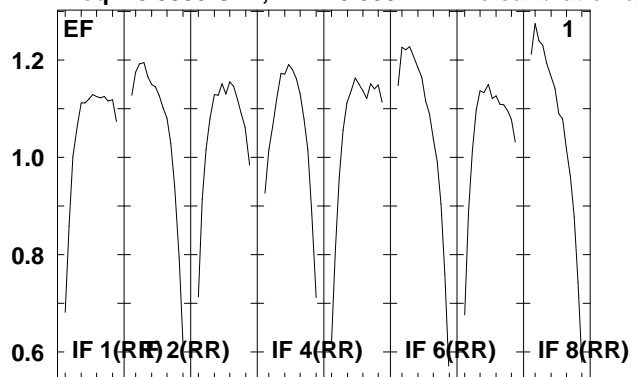

Lower frame: Real Jy  
Total-power spectrum Antenna: \*  
Timerange: 00/23:32:46 to 00/23:34:14

Plot file version 135 created 05-OCT-2009 09:28:38

NGC6240 EH023B 2.UVDATA.1

Freq = 8.3535 GHz, Bw = 8.000 MH No calibration applied and no bandpass applied

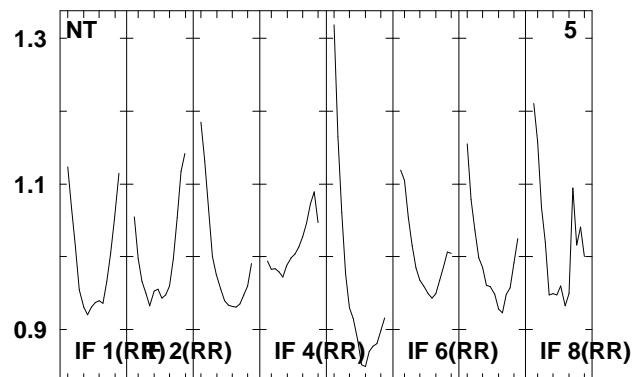
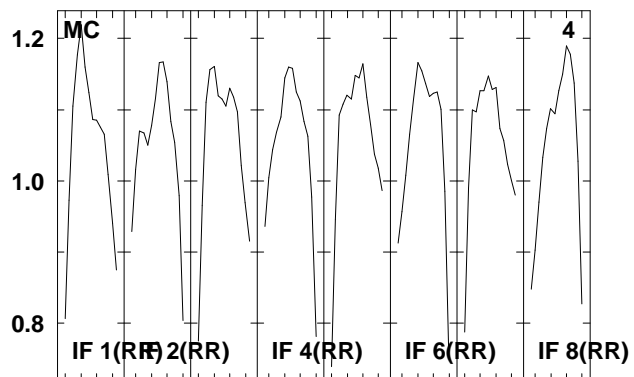
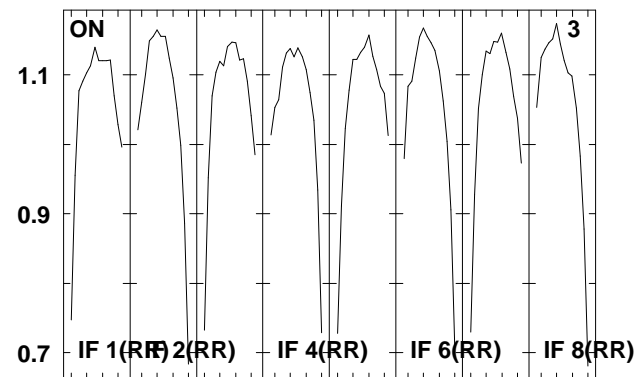
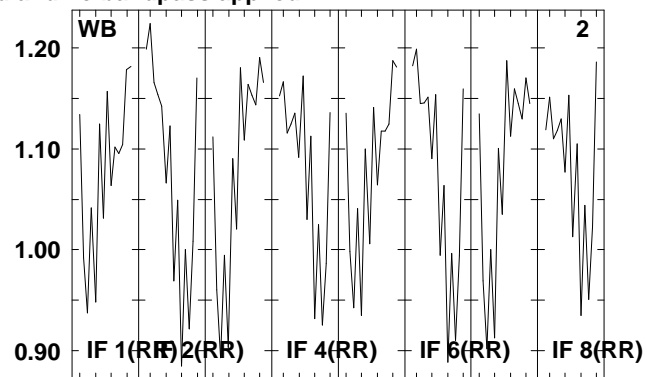
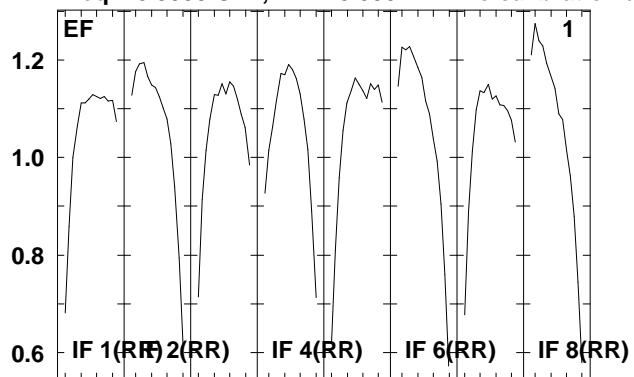

Lower frame: Real Jy  
Total-power spectrum Antenna: \*  
Timerange: 00/23:34:16 to 00/23:37:44

Plot file version 136 created 05-OCT-2009 09:28:38

J1651+01 EH023B 2.UVDATA.1

Freq = 8.3535 GHz, Bw = 8.000 MH No calibration applied and no bandpass applied

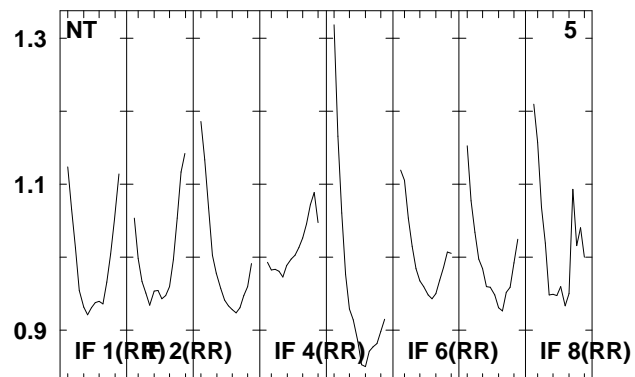
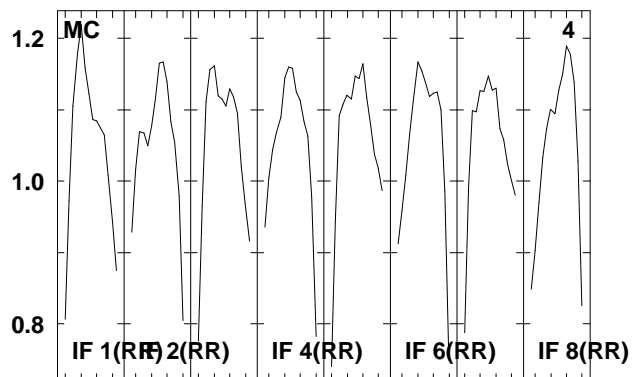
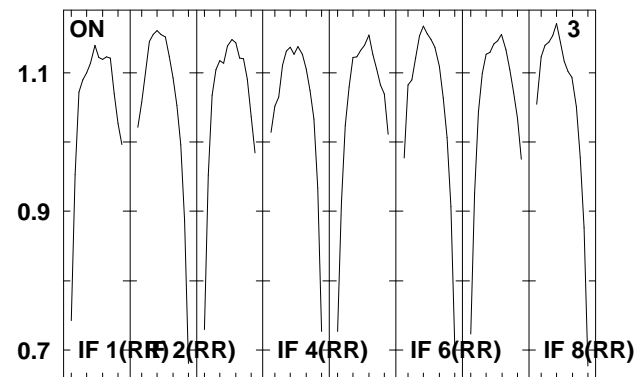
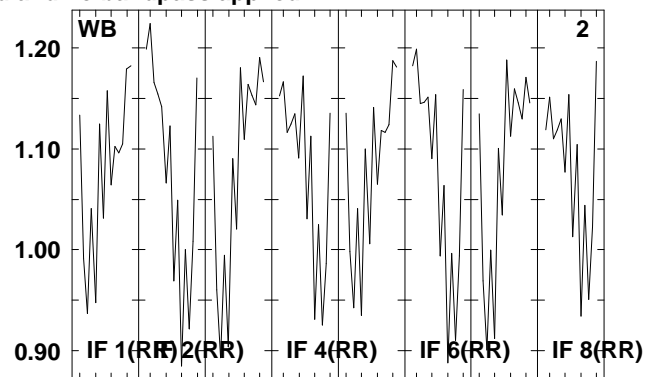
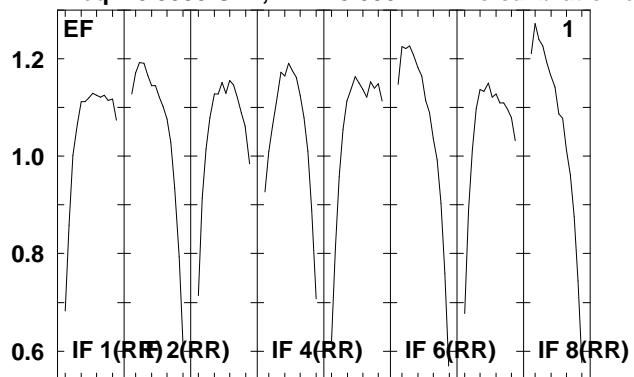

Lower frame: Real Jy  
Total-power spectrum Antenna: \*  
Timerange: 00/23:38:16 to 00/23:39:44



Plot file version 137 created 05-OCT-2009 09:28:38

NGC6240 EH023B 2.UVDATA.1

Freq = 8.3535 GHz, Bw = 8.000 MH No calibration applied and no bandpass applied

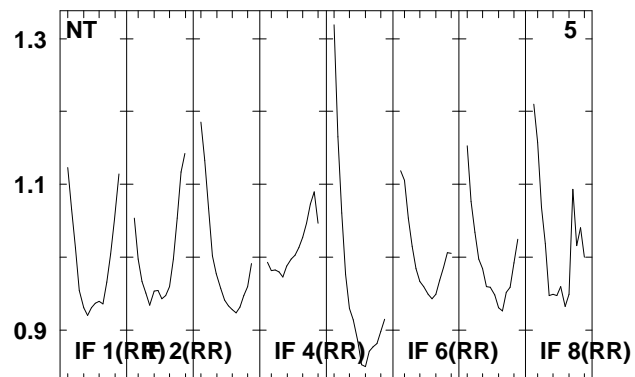
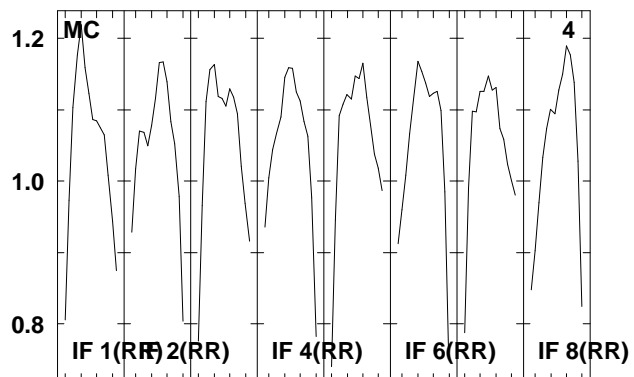
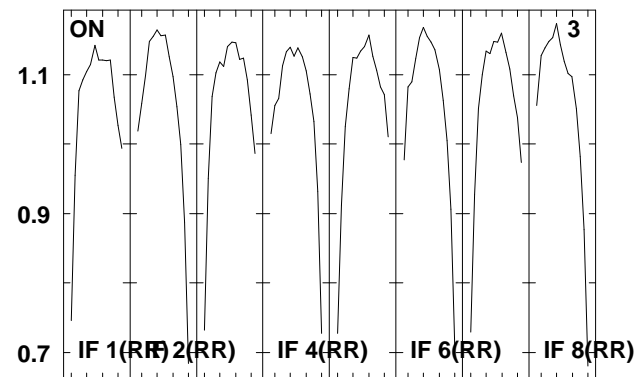
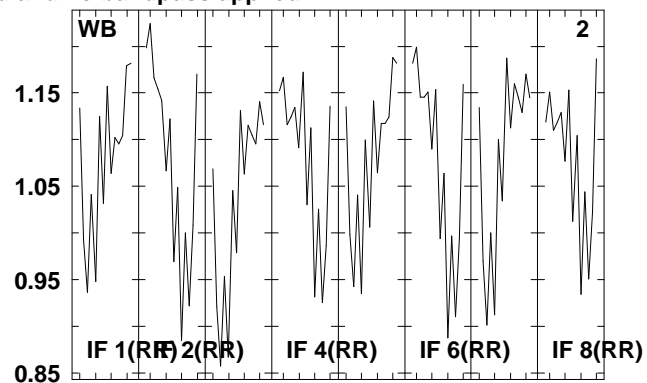
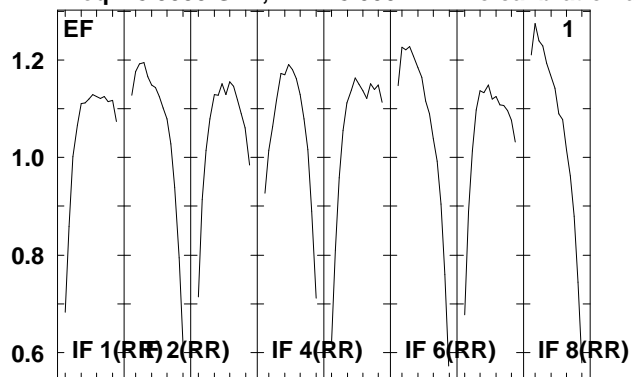

Lower frame: Real Jy  
Total-power spectrum Antenna: \*  
Timerange: 00/23:39:46 to 00/23:43:14

Plot file version 138 created 05-OCT-2009 09:28:38

J1651+01 EH023B 2.UVDATA.1

Freq = 8.3535 GHz, Bw = 8.000 MH No calibration applied and no bandpass applied

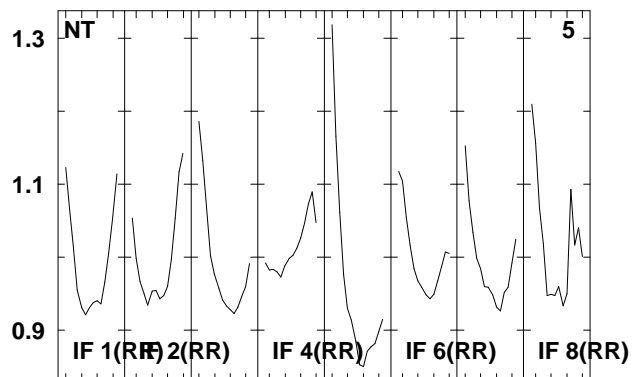
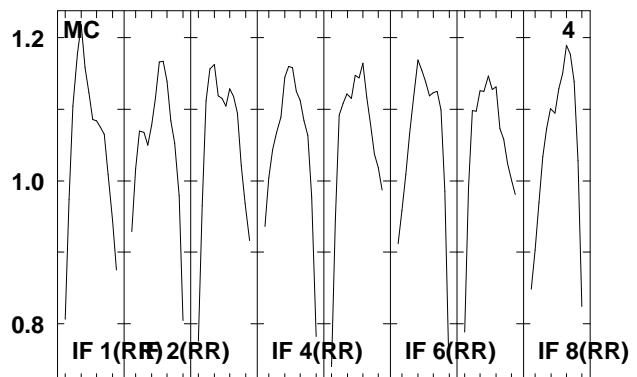
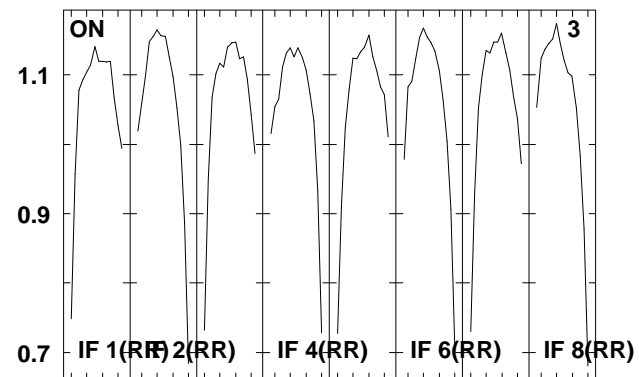
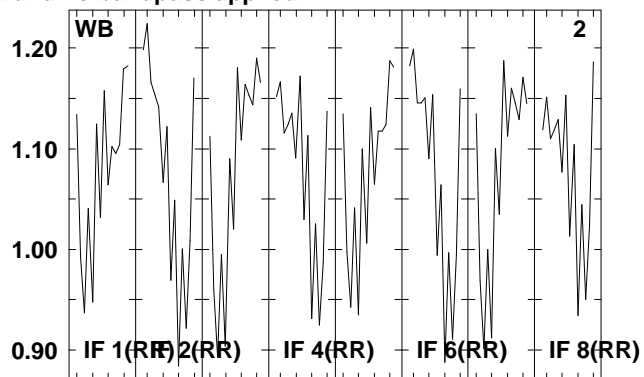
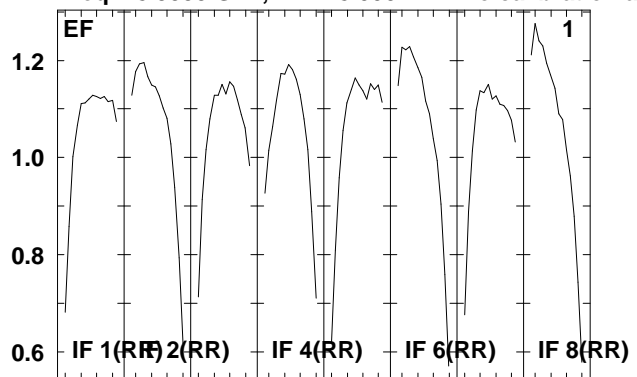

Lower frame: Real Jy  
Total-power spectrum Antenna: \*  
Timerange: 00/23:43:16 to 00/23:44:44

Plot file version 139 created 05-OCT-2009 09:28:38

NGC6240 EH023B 2.UVDATA.1

Freq = 8.3535 GHz, Bw = 8.000 MH No calibration applied and no bandpass applied

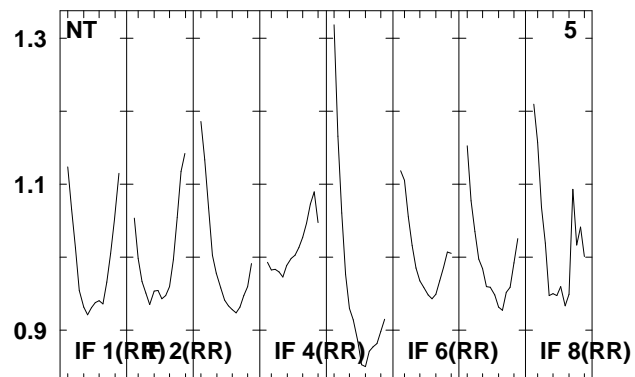
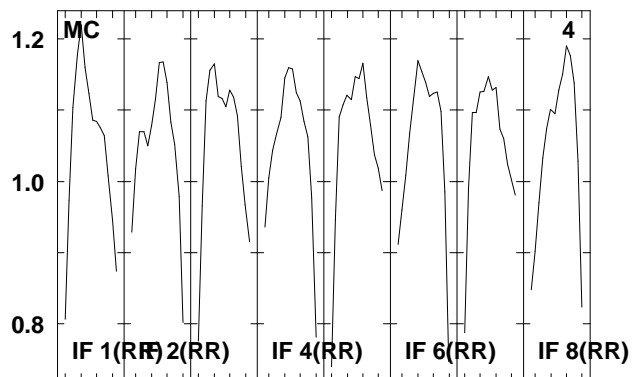
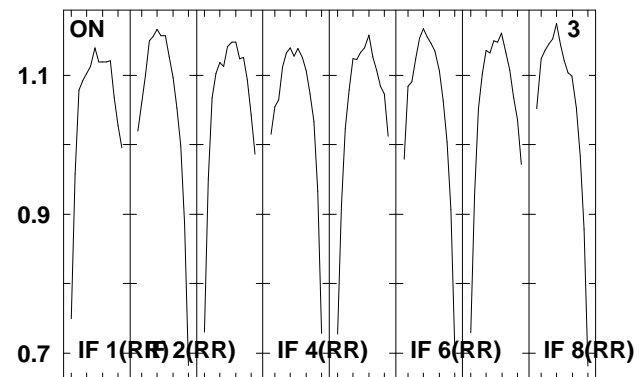
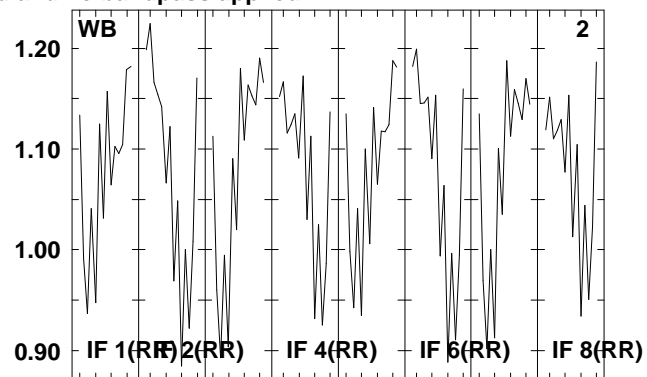
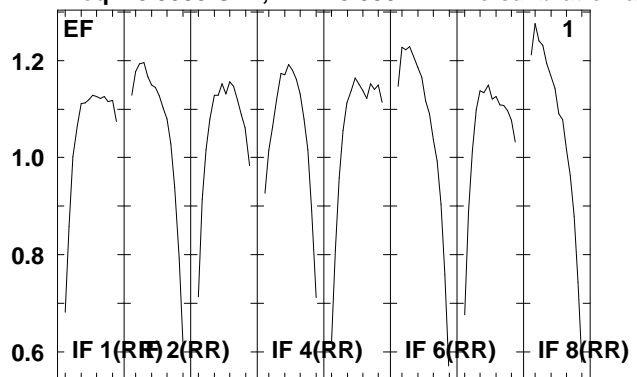

Lower frame: Real Jy  
Total-power spectrum Antenna: \*  
Timerange: 00/23:44:46 to 00/23:48:14

Plot file version 140 created 05-OCT-2009 09:28:38

J1651+01 EH023B 2.UVDATA.1

Freq = 8.3535 GHz, Bw = 8.000 MH No calibration applied and no bandpass applied

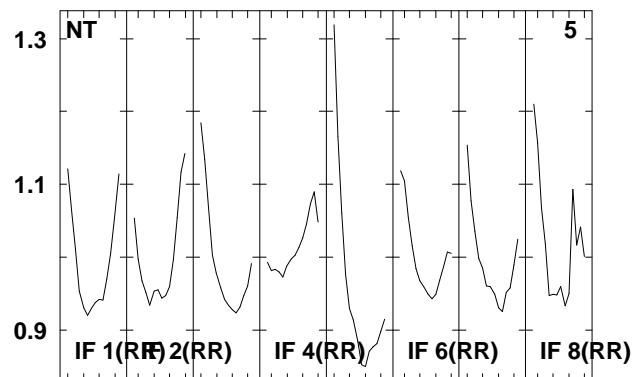
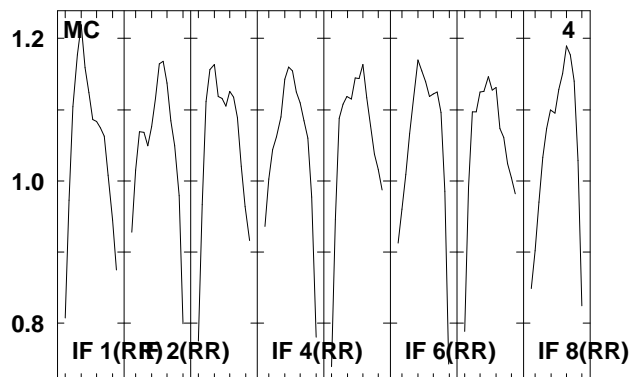
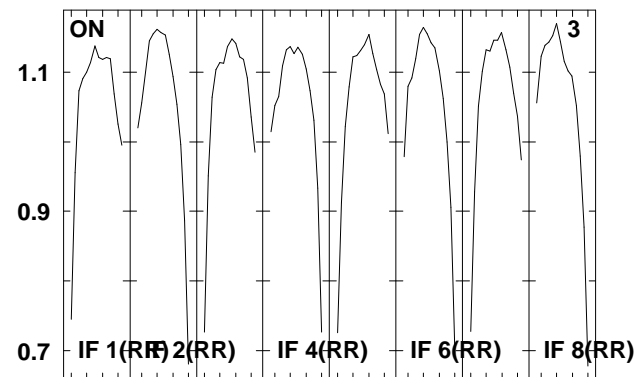
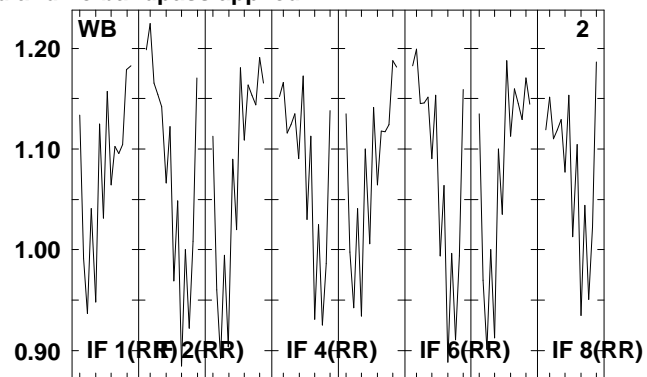
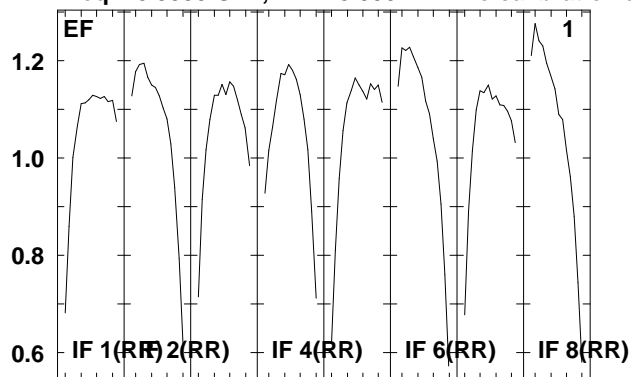

Lower frame: Real Jy  
Total-power spectrum Antenna: \*  
Timerange: 00/23:48:46 to 00/23:50:14

Plot file version 141 created 05-OCT-2009 09:28:38

3C345 EH023B 2.UVDATA.1

Freq = 8.3535 GHz, Bw = 8.000 MH No calibration applied and no bandpass applied

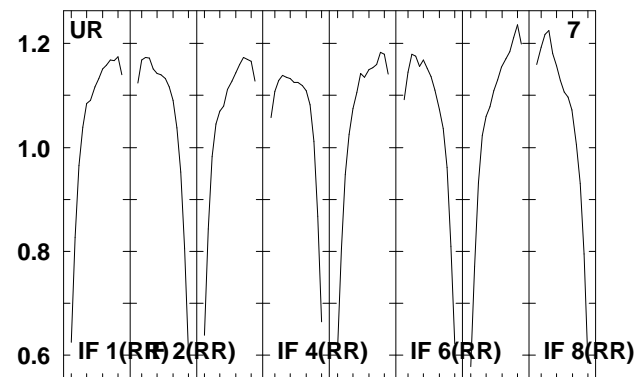
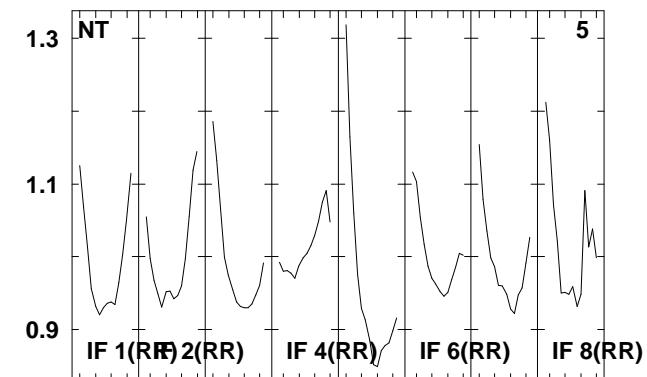
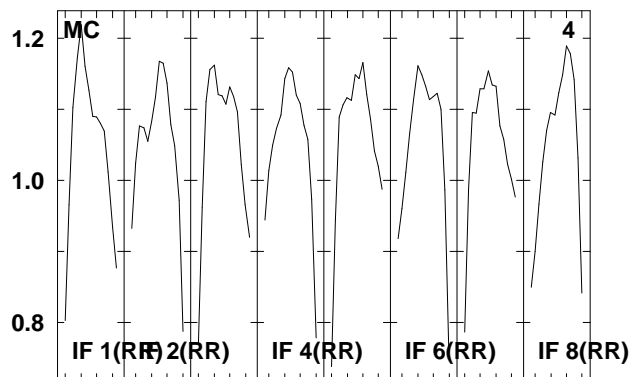
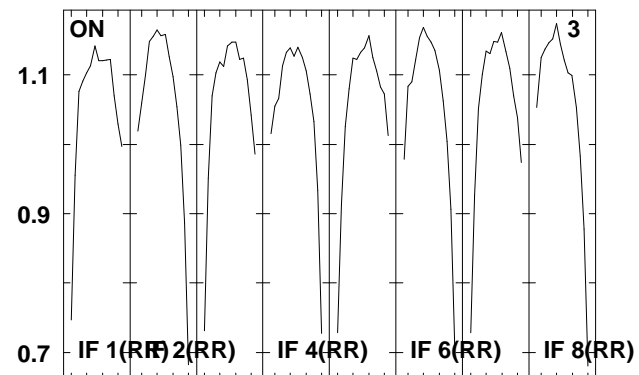
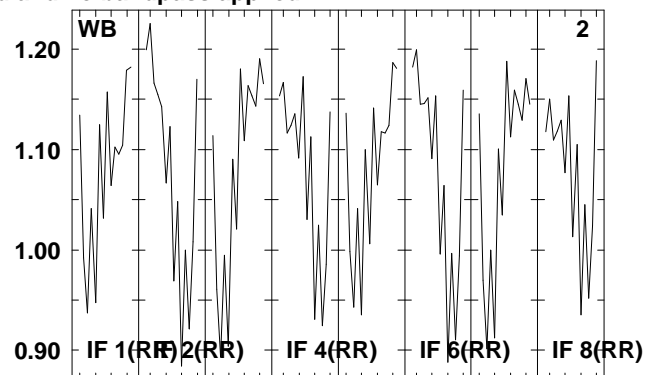
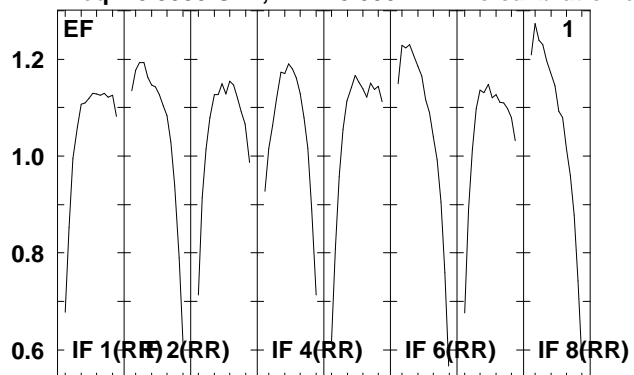

Lower frame: Real Jy  
Total-power spectrum Antenna: \*  
Timerange: 00/23:52:52 to 00/23:57:46

Plot file version 142 created 05-OCT-2009 09:28:39

J1651+01 EH023B 2.UVDATA.1

Freq = 8.3535 GHz, Bw = 8.000 MH No calibration applied and no bandpass applied

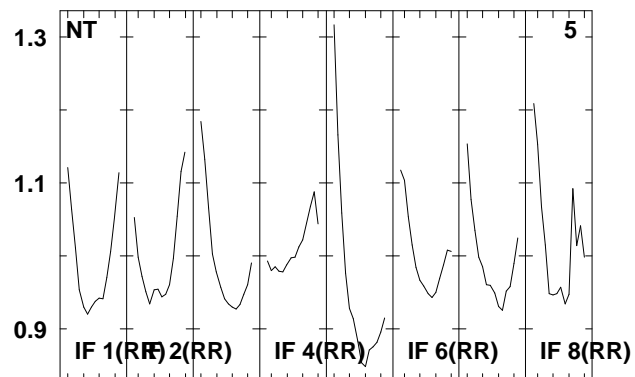
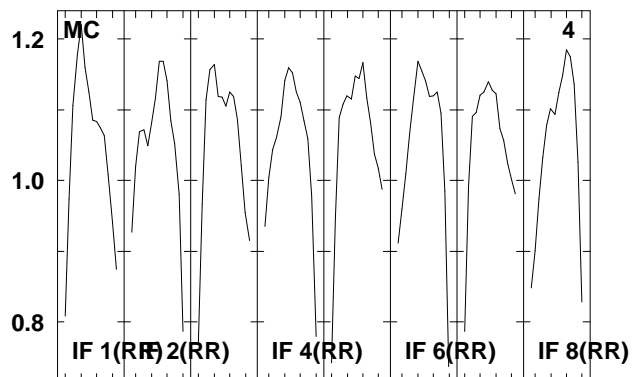
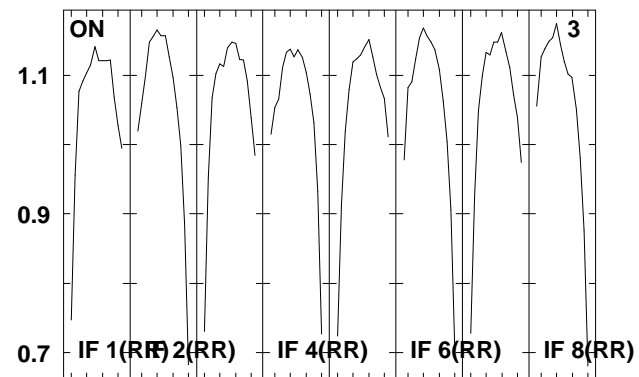
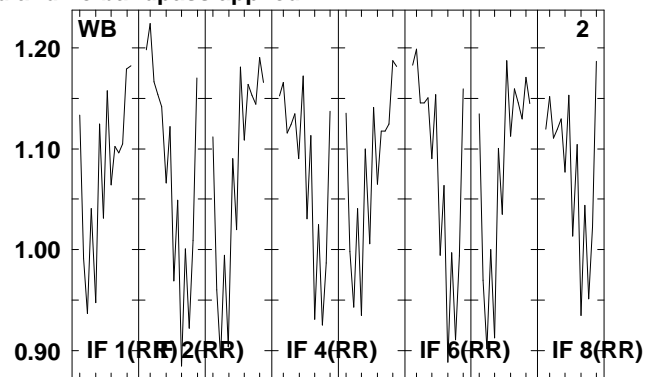
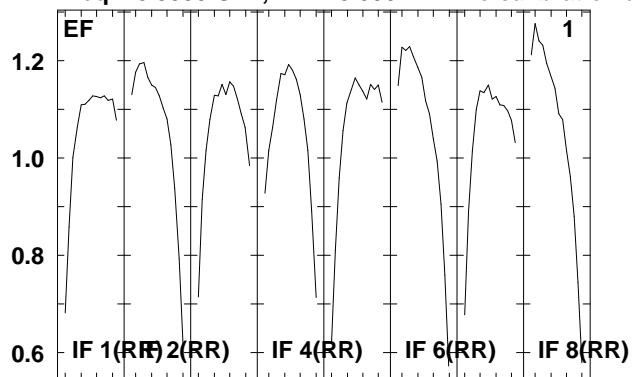

Lower frame: Real Jy  
Total-power spectrum Antenna: \*  
Timerange: 01/00:00:26 to 01/00:01:52

Plot file version 143 created 05-OCT-2009 09:28:39

NGC6240 EH023B 2.UVDATA.1

Freq = 8.3535 GHz, Bw = 8.000 MH No calibration applied and no bandpass applied

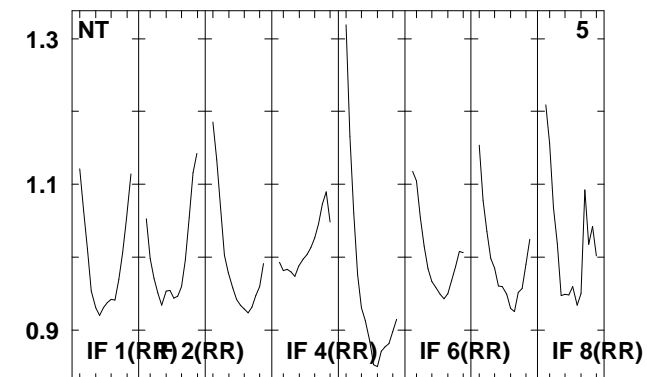
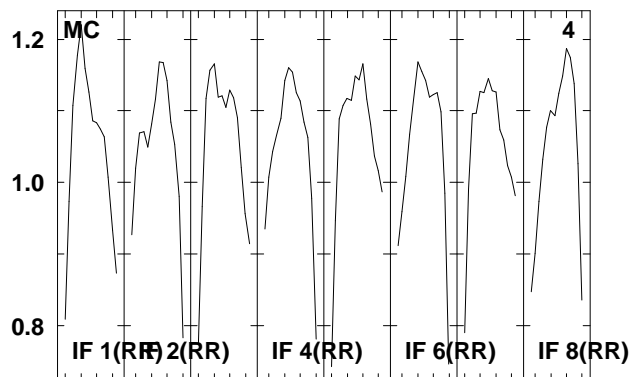
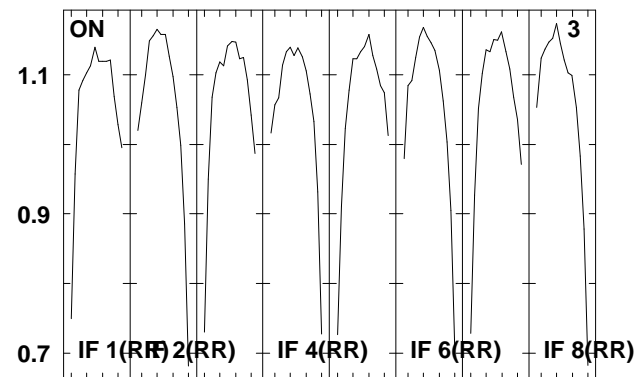
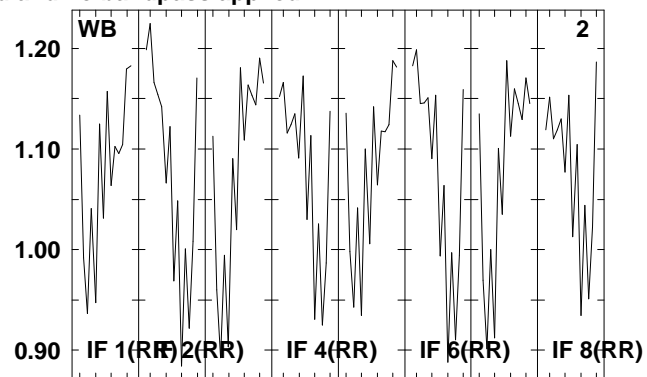
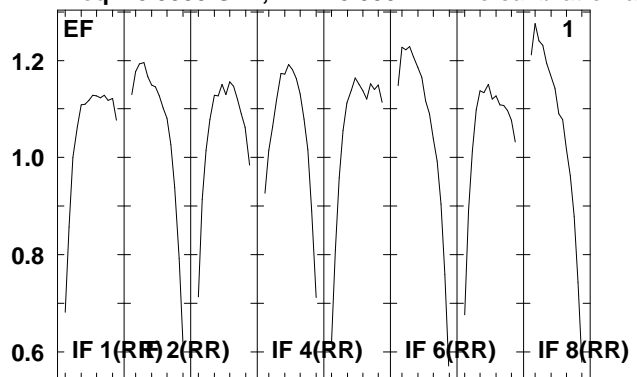

Lower frame: Real Jy  
Total-power spectrum Antenna: \*  
Timerange: 01/00:01:58 to 01/00:05:24

Plot file version 144 created 05-OCT-2009 09:28:39

J1651+01 EH023B 2.UVDATA.1

Freq = 8.3535 GHz, Bw = 8.000 MH No calibration applied and no bandpass applied

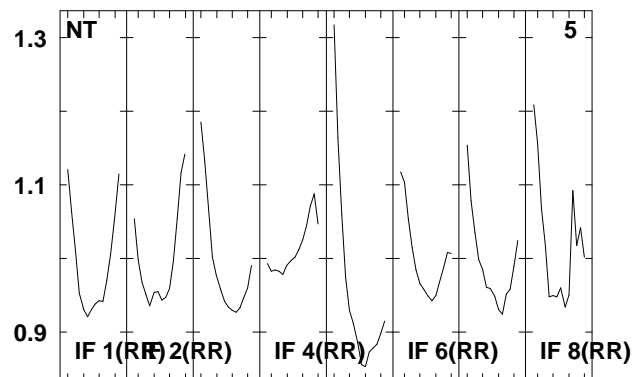
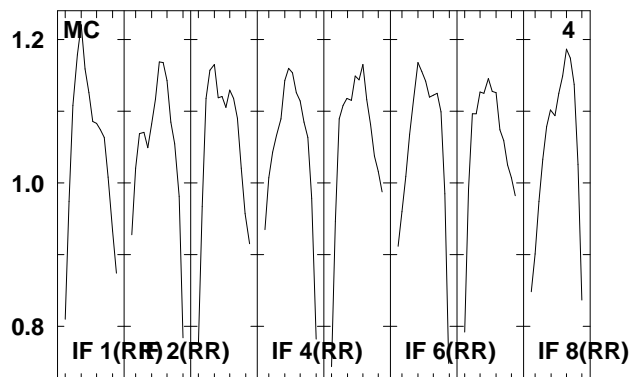
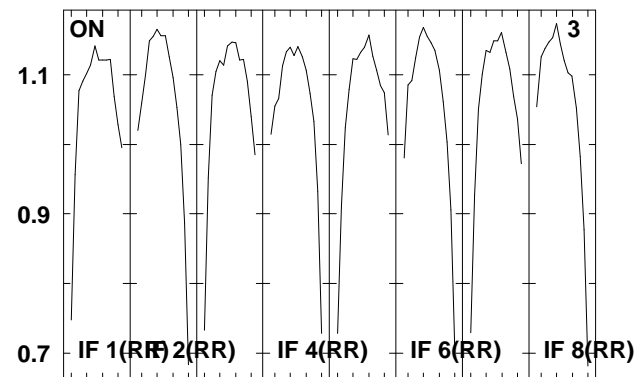
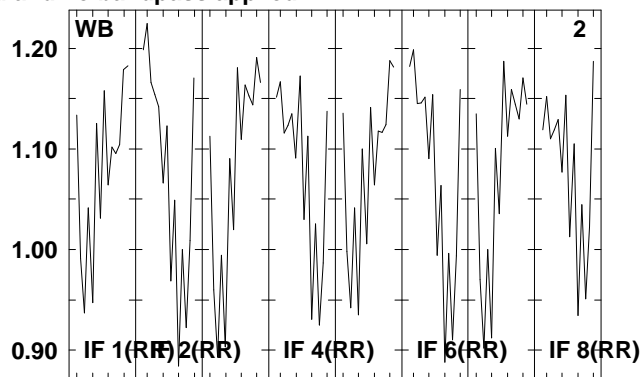
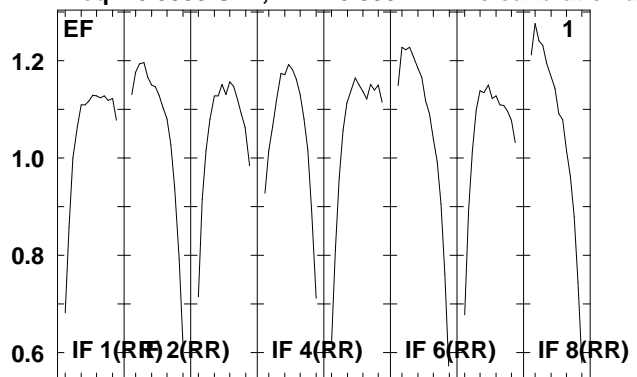

Lower frame: Real Jy  
Total-power spectrum Antenna: \*  
Timerange: 01/00:05:26 to 01/00:06:54



Plot file version 145 created 05-OCT-2009 09:28:39

NGC6240 EH023B 2.UVDATA.1

Freq = 8.3535 GHz, Bw = 8.000 MH No calibration applied and no bandpass applied

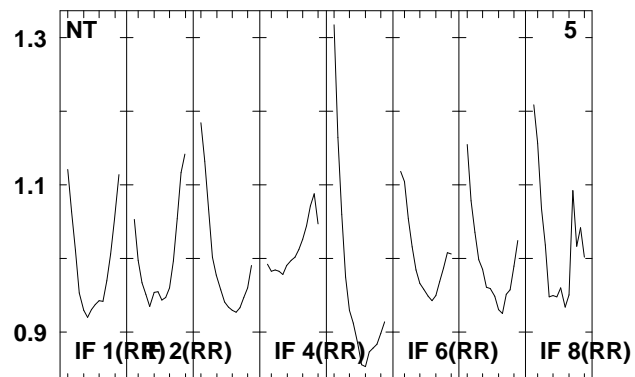
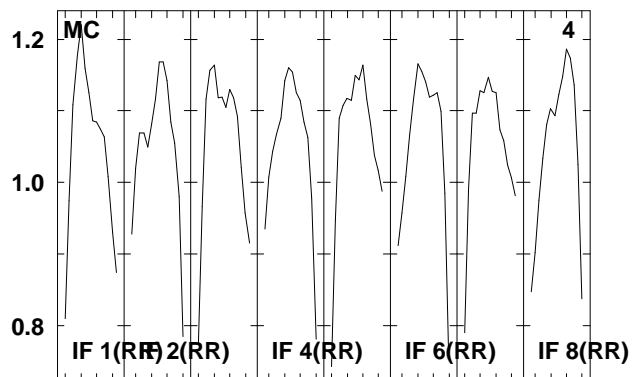
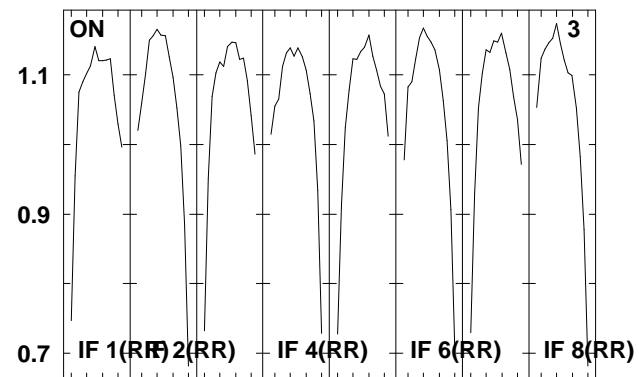
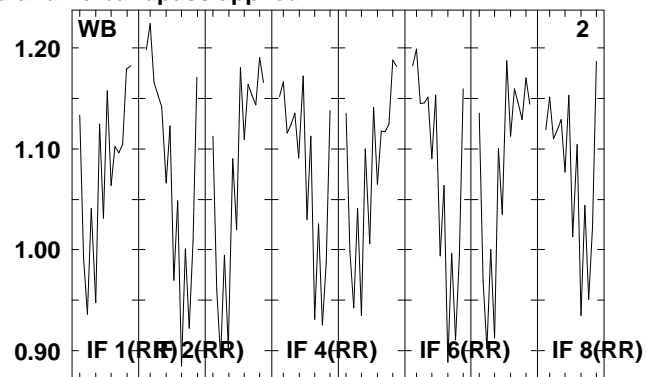
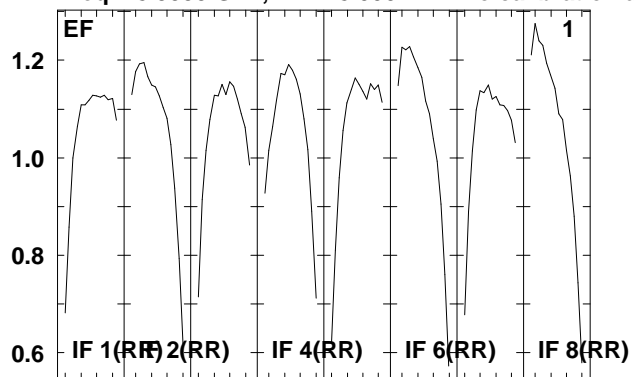

Lower frame: Real Jy  
Total-power spectrum Antenna: \*  
Timerange: 01/00:06:56 to 01/00:10:24

Plot file version 146 created 05-OCT-2009 09:28:39

J1651+01 EH023B 2.UVDATA.1

Freq = 8.3535 GHz, Bw = 8.000 MH No calibration applied and no bandpass applied

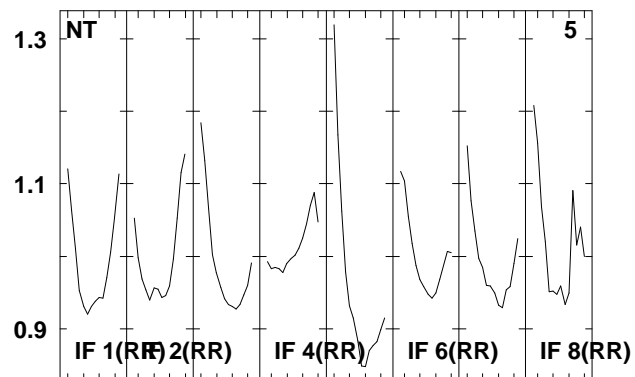
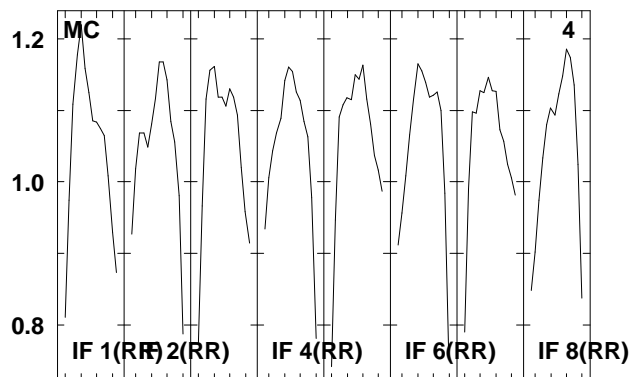
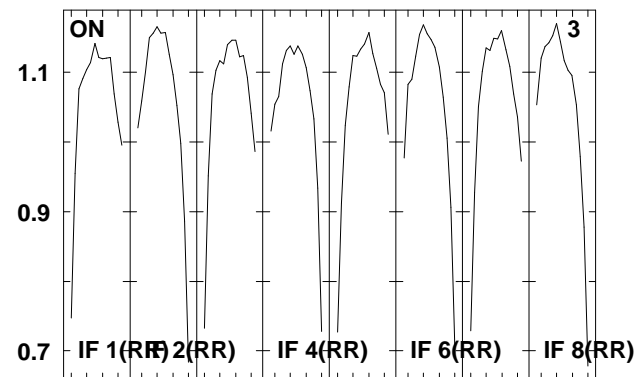
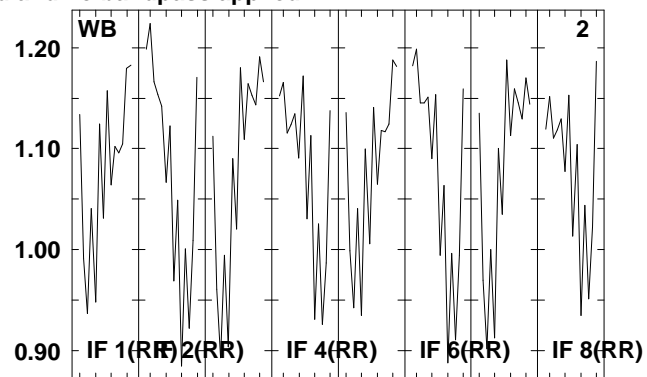
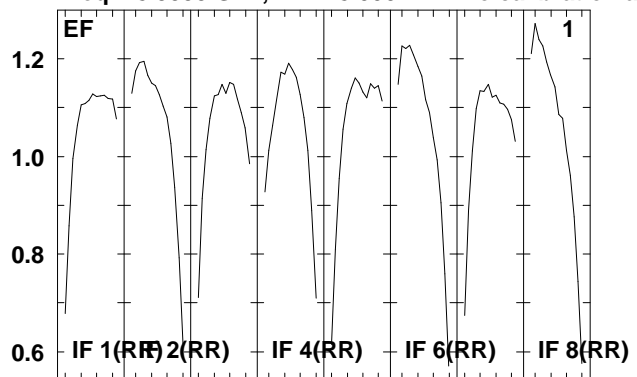

Lower frame: Real Jy  
Total-power spectrum Antenna: \*  
Timerange: 01/00:10:56 to 01/00:12:24

Plot file version 147 created 05-OCT-2009 09:28:40

NGC6240 EH023B 2.UVDATA.1

Freq = 8.3535 GHz, Bw = 8.000 MH No calibration applied and no bandpass applied

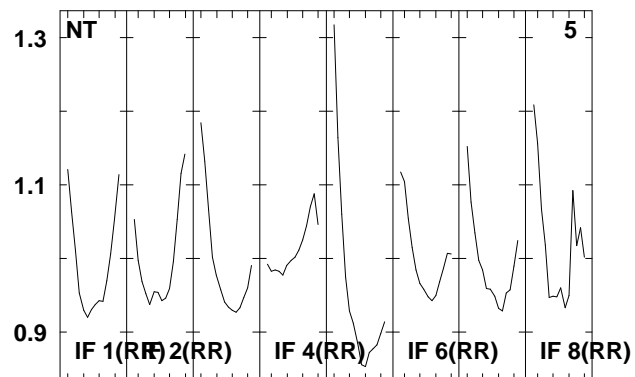
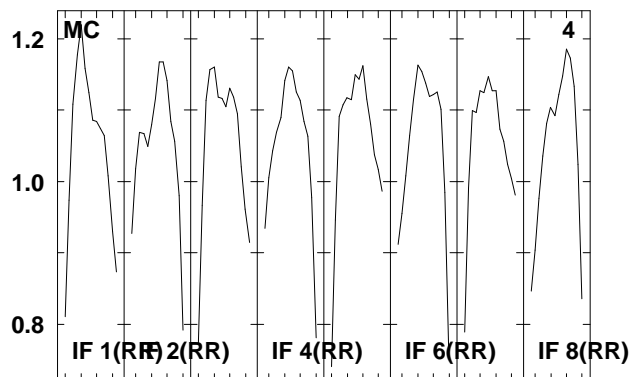
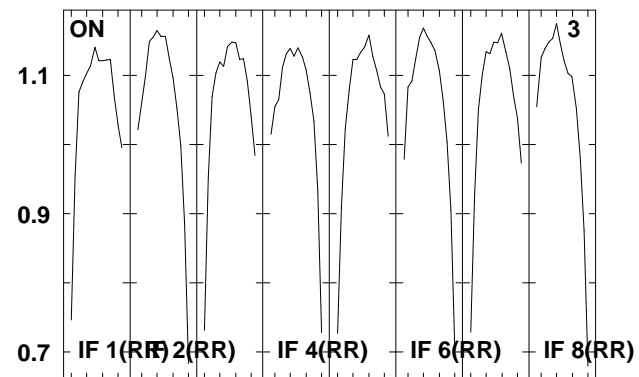
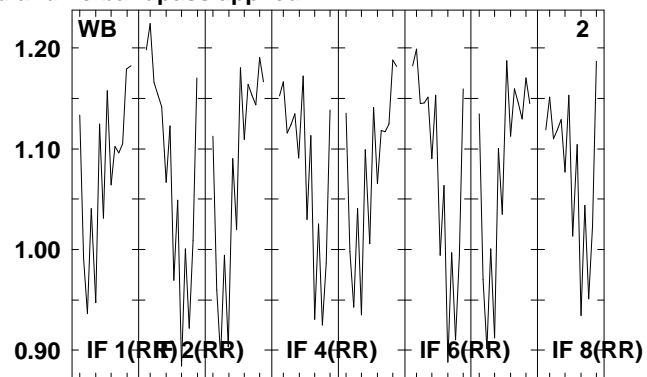
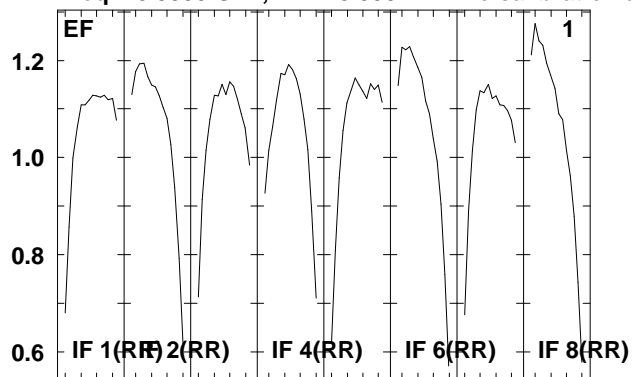

Lower frame: Real Jy  
Total-power spectrum Antenna: \*  
Timerange: 01/00:12:26 to 01/00:15:54

Plot file version 148 created 05-OCT-2009 09:28:40

J1651+01 EH023B 2.UVDATA.1

Freq = 8.3535 GHz, Bw = 8.000 MH No calibration applied and no bandpass applied

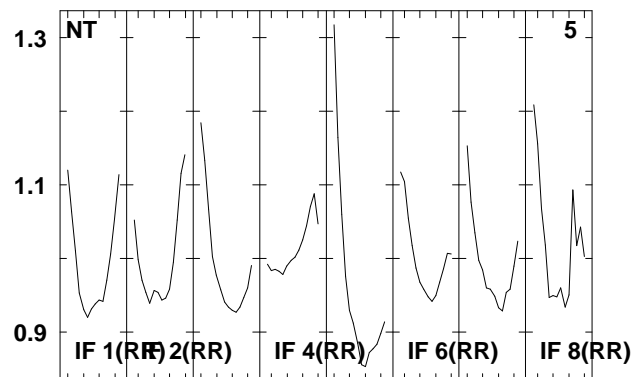
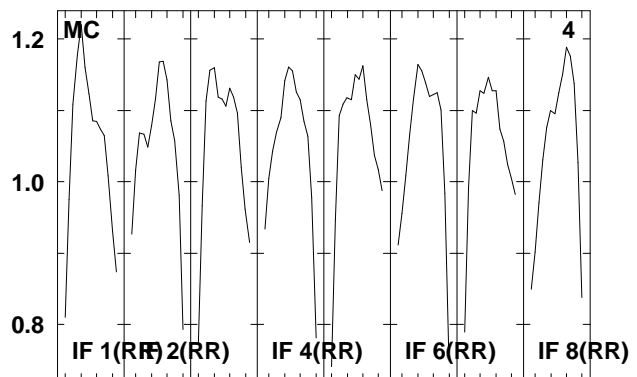
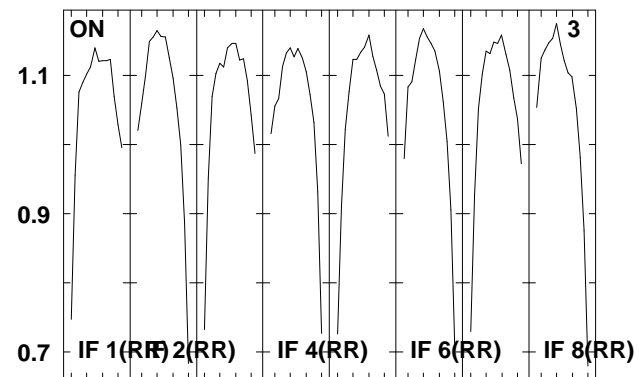
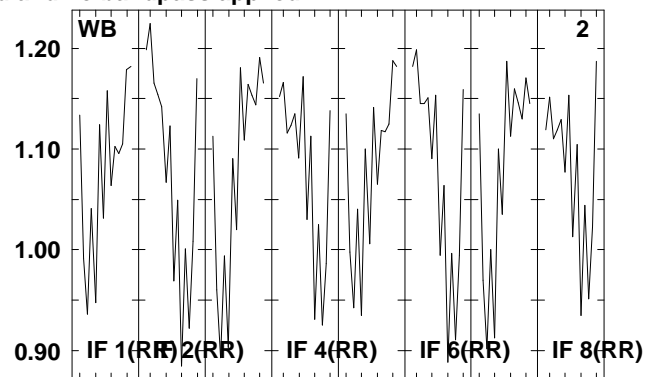
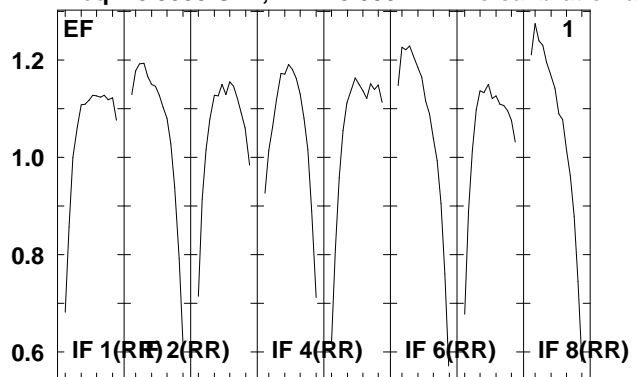

Lower frame: Real Jy  
Total-power spectrum Antenna: \*  
Timerange: 01/00:15:56 to 01/00:17:24

Plot file version 149 created 05-OCT-2009 09:28:40

NGC6240 EH023B 2.UVDATA.1

Freq = 8.3535 GHz, Bw = 8.000 MH No calibration applied and no bandpass applied

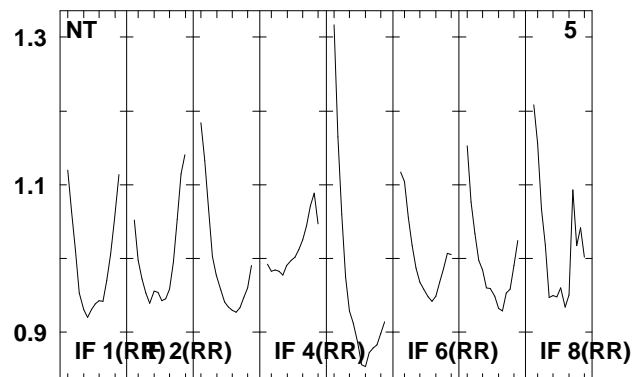
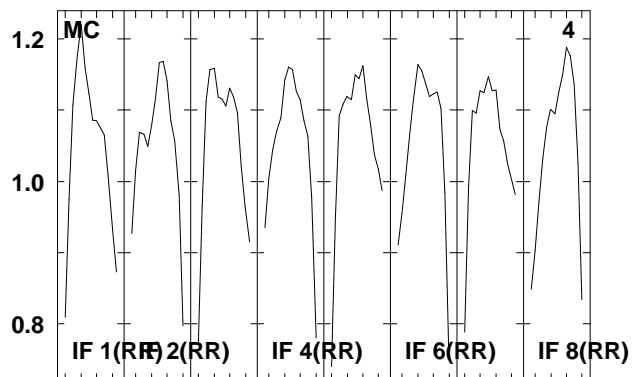
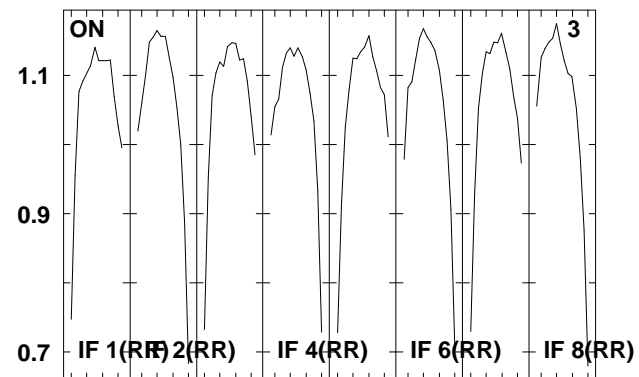
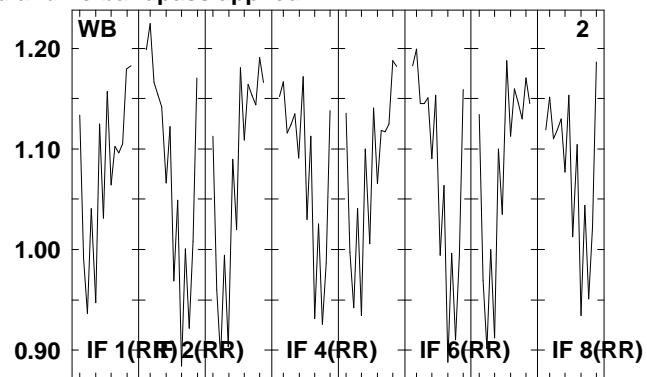
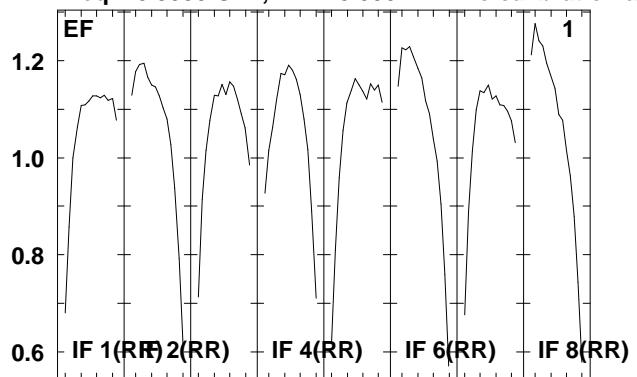

Lower frame: Real Jy  
Total-power spectrum Antenna: \*  
Timerange: 01/00:17:26 to 01/00:20:54

Plot file version 150 created 05-OCT-2009 09:28:40

J1651+01 EH023B 2.UVDATA.1

Freq = 8.3535 GHz, Bw = 8.000 MH No calibration applied and no bandpass applied

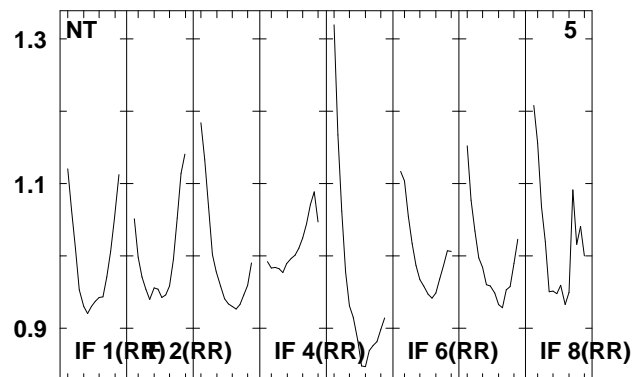
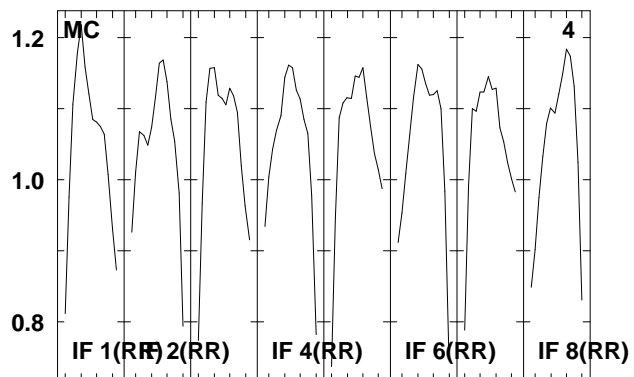
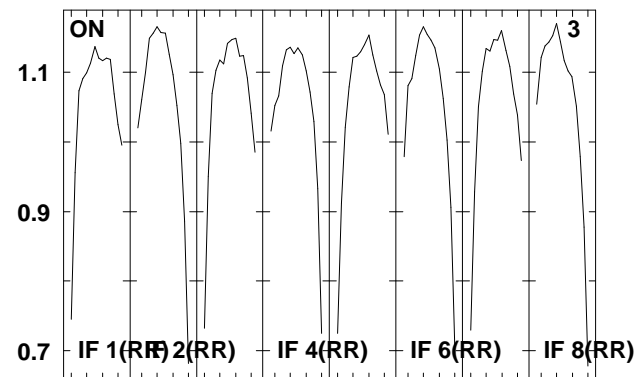
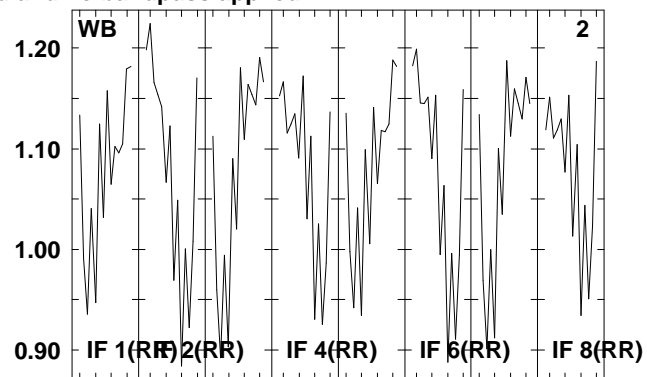
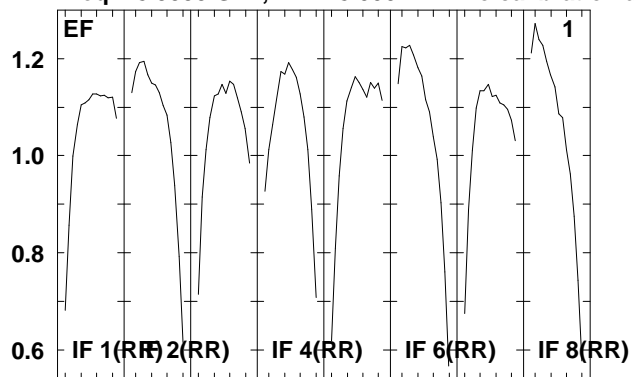

Lower frame: Real Jy  
Total-power spectrum Antenna: \*  
Timerange: 01/00:21:26 to 01/00:22:54

Plot file version 151 created 05-OCT-2009 09:28:40

NGC6240 EH023B 2.UVDATA.1

Freq = 8.3535 GHz, Bw = 8.000 MH No calibration applied and no bandpass applied

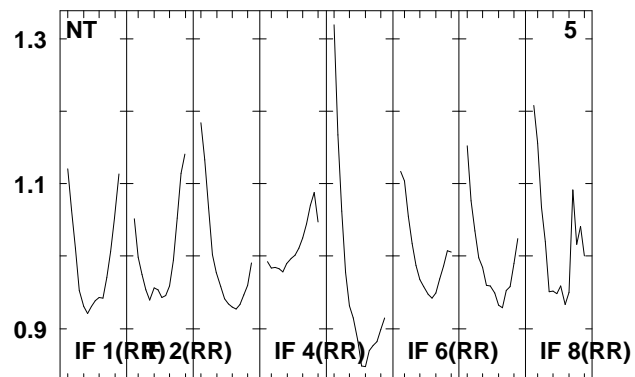
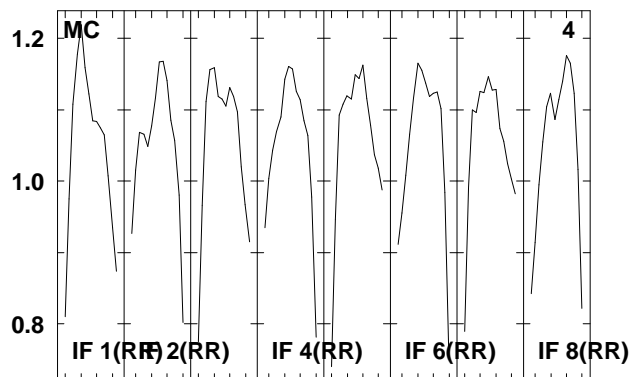
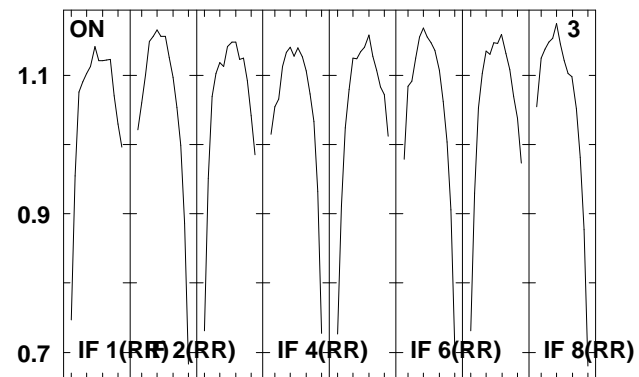
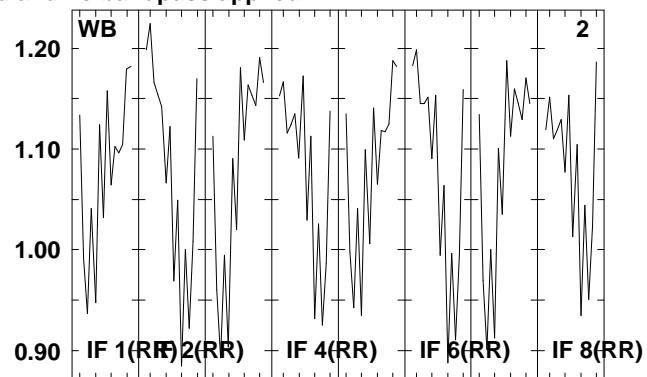
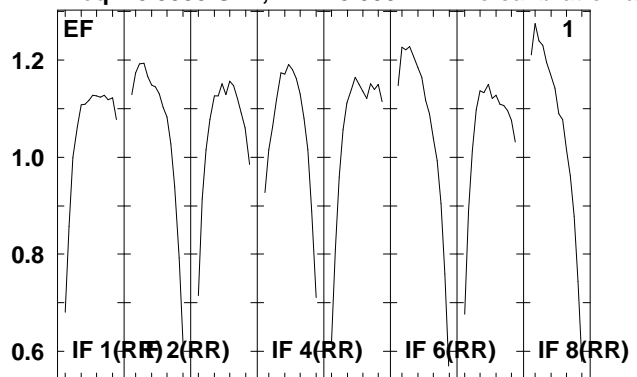

Lower frame: Real Jy  
Total-power spectrum Antenna: \*  
Timerange: 01/00:22:56 to 01/00:26:24

Plot file version 152 created 05-OCT-2009 09:28:40

J1651+01 EH023B 2.UVDATA.1

Freq = 8.3535 GHz, Bw = 8.000 MH No calibration applied and no bandpass applied

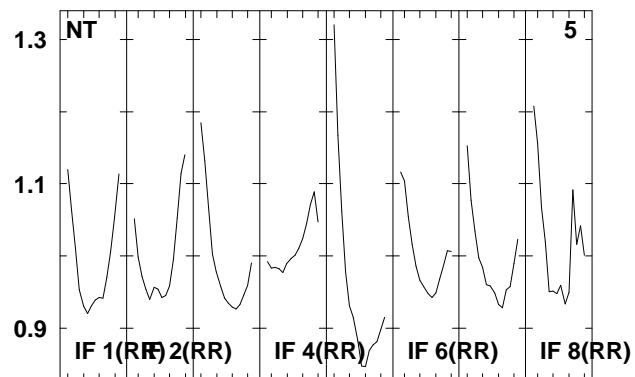
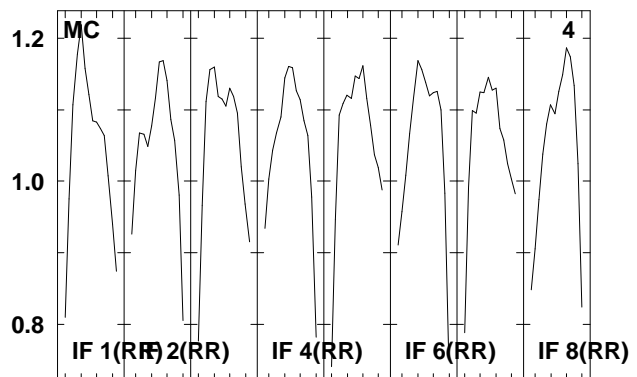
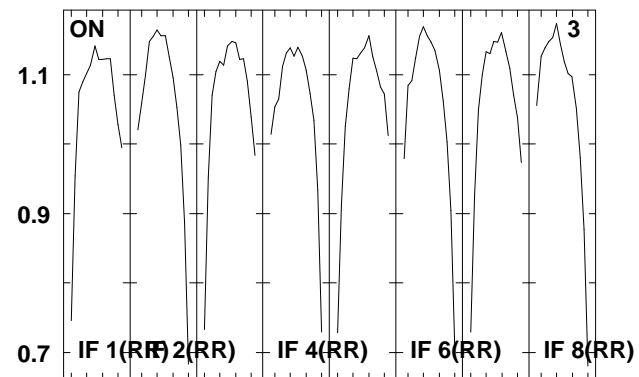
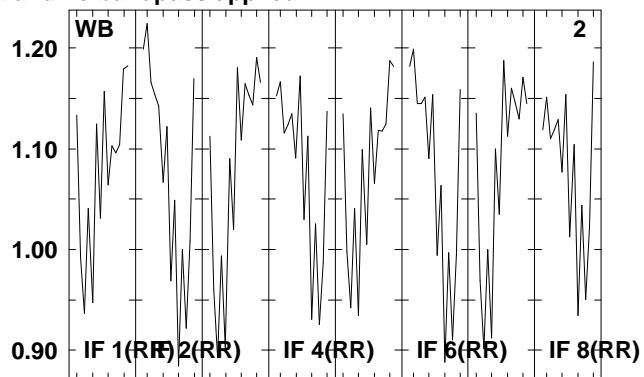
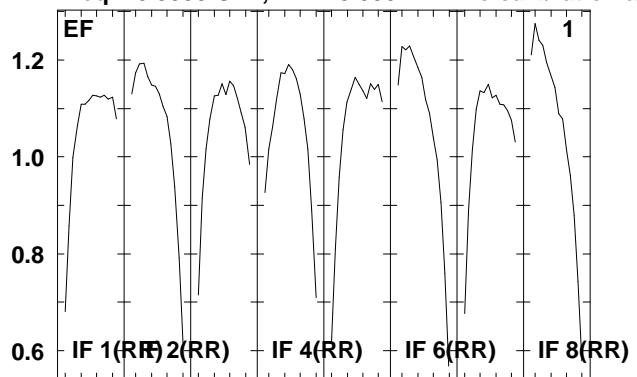

Lower frame: Real Jy  
Total-power spectrum Antenna: \*  
Timerange: 01/00:26:26 to 01/00:27:54



Plot file version 153 created 05-OCT-2009 09:28:40

NGC6240 EH023B 2.UVDATA.1

Freq = 8.3535 GHz, Bw = 8.000 MH No calibration applied and no bandpass applied

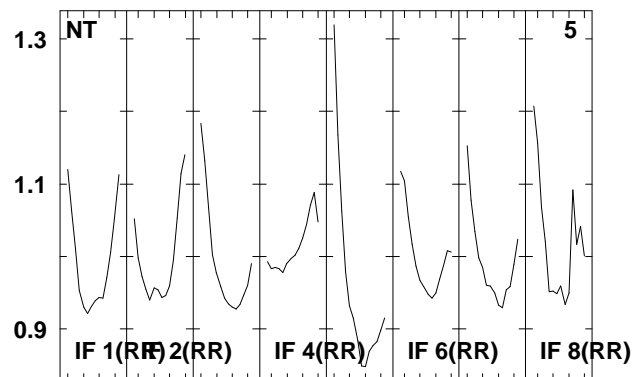
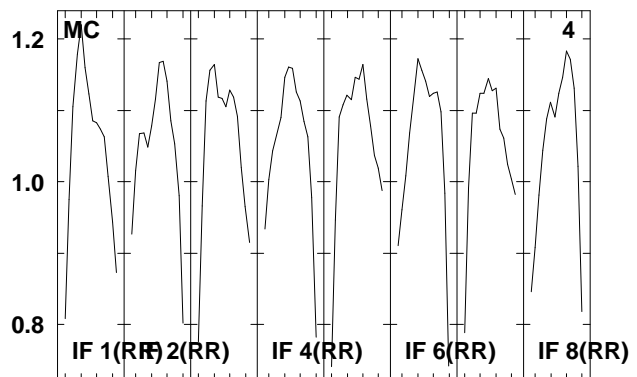
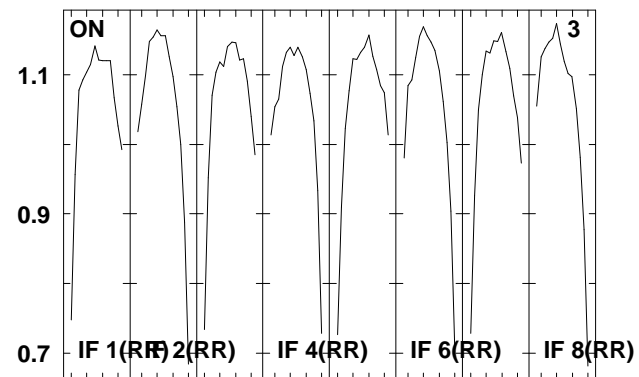
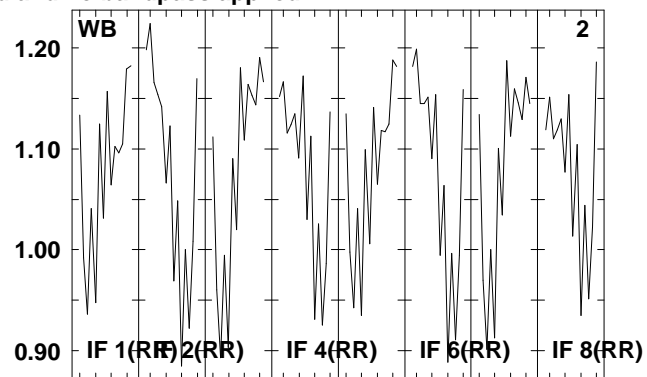
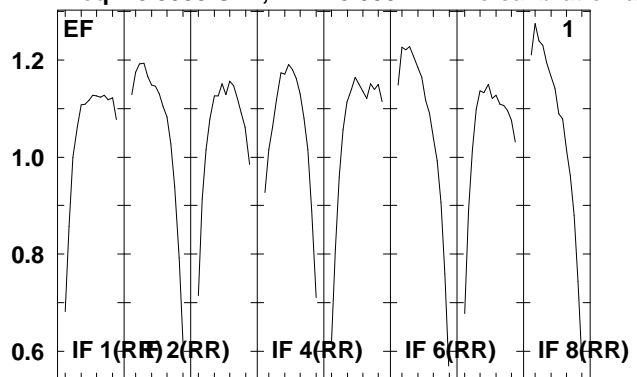

Lower frame: Real Jy  
Total-power spectrum Antenna: \*  
Timerange: 01/00:27:56 to 01/00:31:24

Plot file version 154 created 05-OCT-2009 09:28:40

J1651+01 EH023B 2.UVDATA.1

Freq = 8.3535 GHz, Bw = 8.000 MH No calibration applied and no bandpass applied

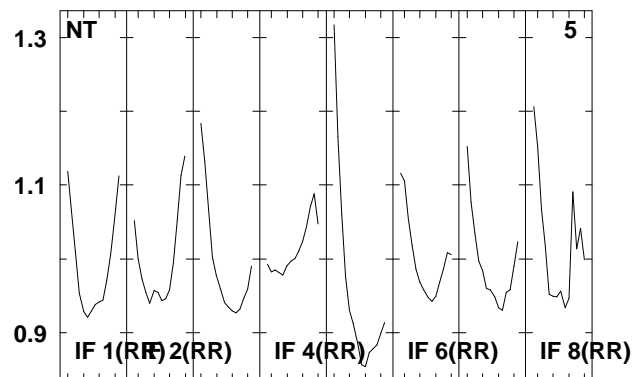
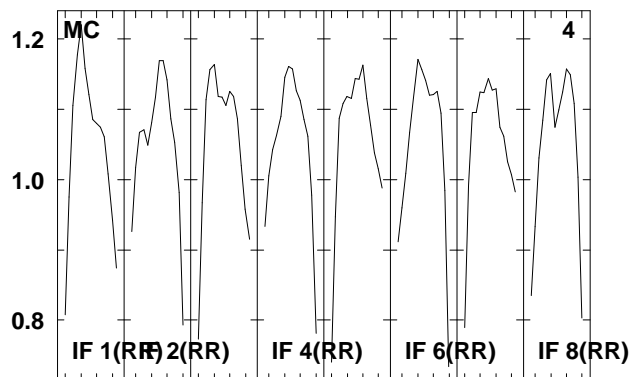
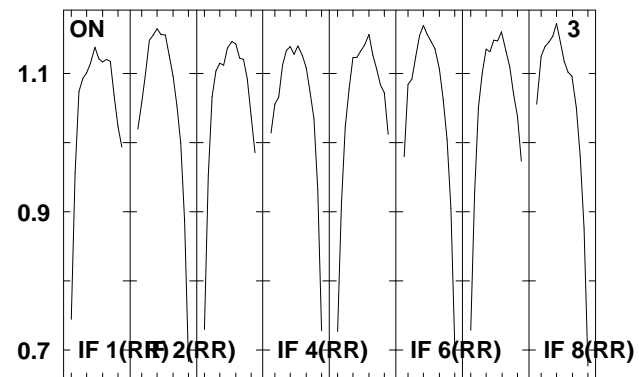
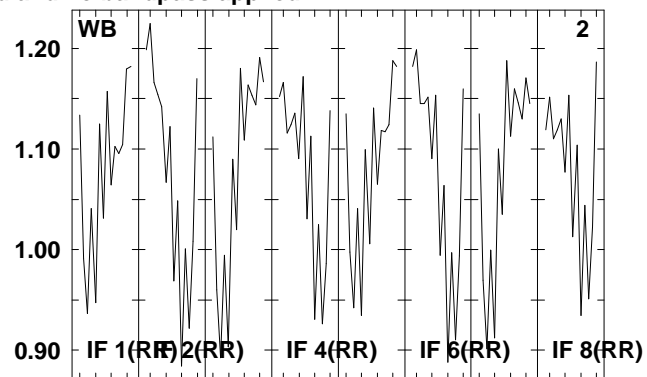
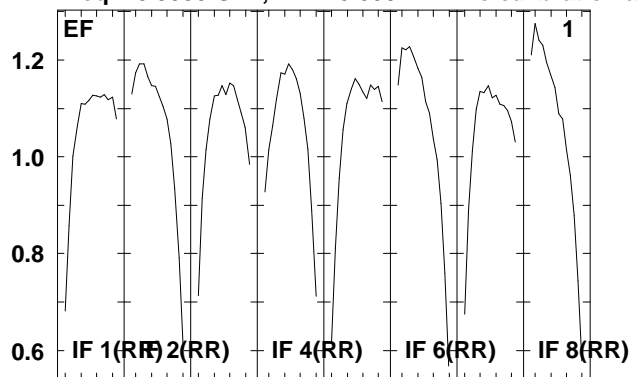

Lower frame: Real Jy  
Total-power spectrum Antenna: \*  
Timerange: 01/00:31:56 to 01/00:33:24

Plot file version 155 created 05-OCT-2009 09:28:41

NGC6240 EH023B 2.UVDATA.1

Freq = 8.3535 GHz, Bw = 8.000 MH No calibration applied and no bandpass applied

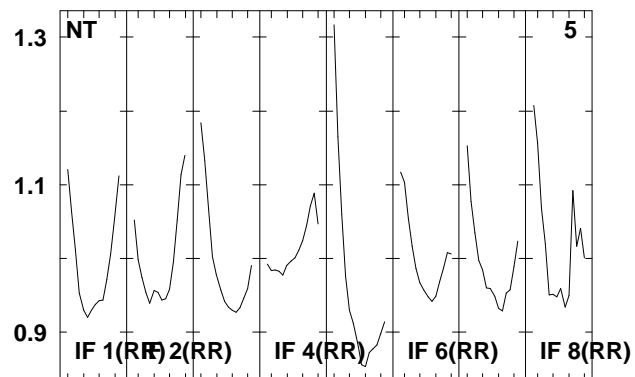
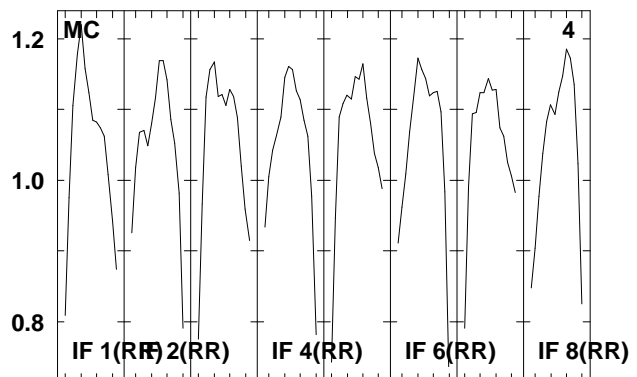
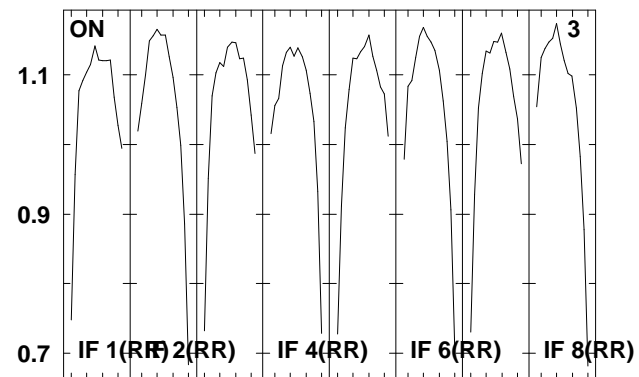
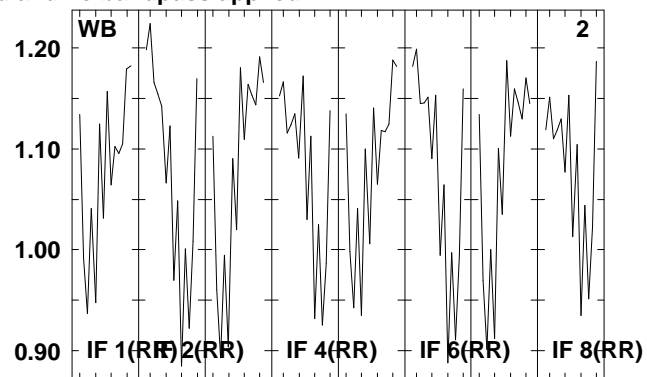
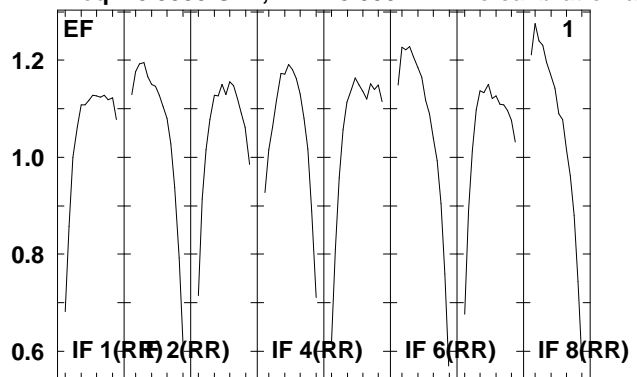

Lower frame: Real Jy  
Total-power spectrum Antenna: \*  
Timerange: 01/00:33:26 to 01/00:36:54

Plot file version 156 created 05-OCT-2009 09:28:41

J1651+01 EH023B 2.UVDATA.1

Freq = 8.3535 GHz, Bw = 8.000 MH No calibration applied and no bandpass applied

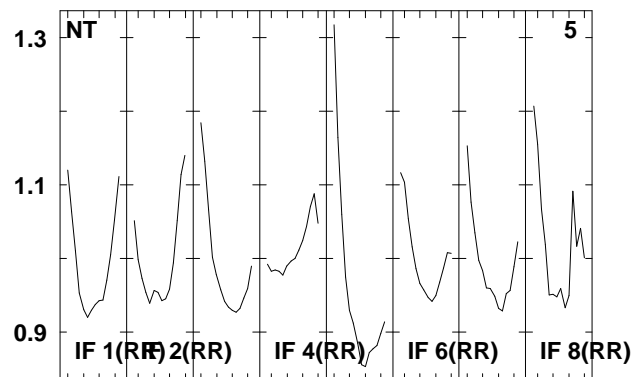
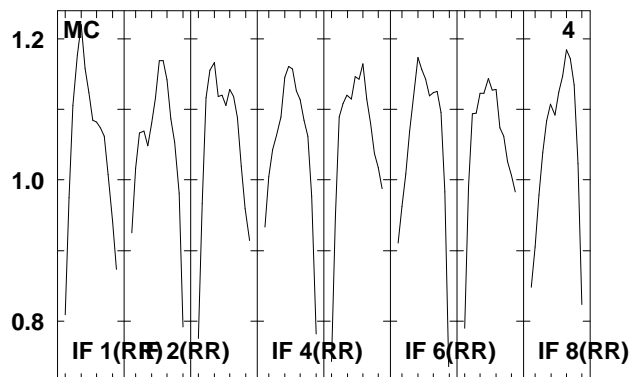
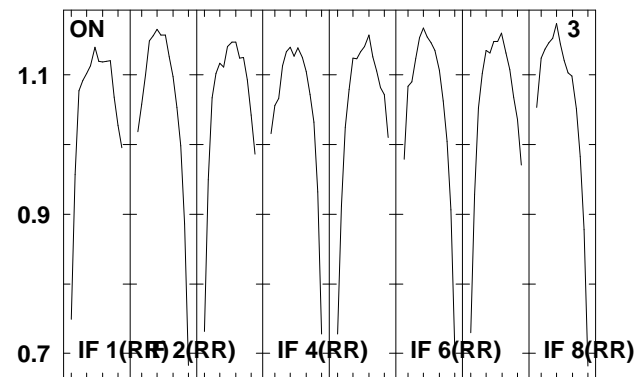
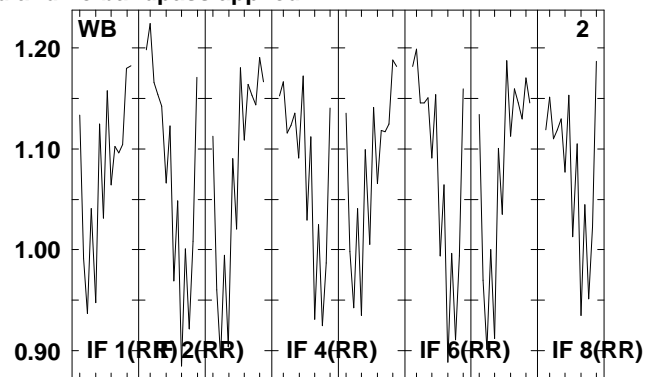
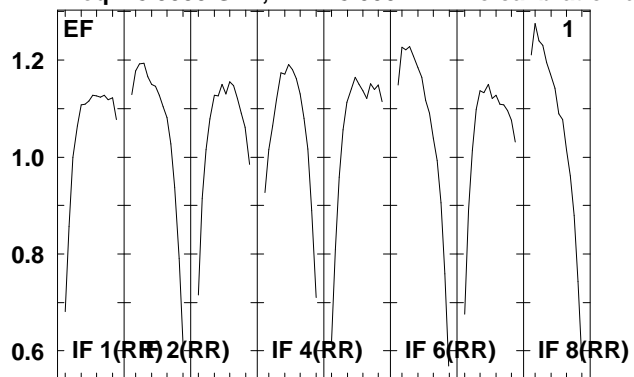

Lower frame: Real Jy  
Total-power spectrum Antenna: \*  
Timerange: 01/00:36:56 to 01/00:38:24

Plot file version 157 created 05-OCT-2009 09:28:41

NGC6240 EH023B 2.UVDATA.1

Freq = 8.3535 GHz, Bw = 8.000 MH No calibration applied and no bandpass applied

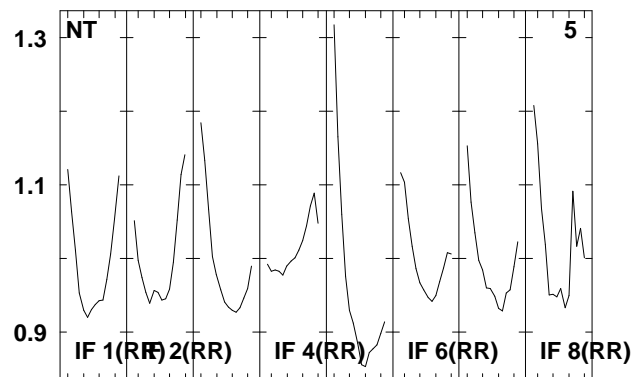
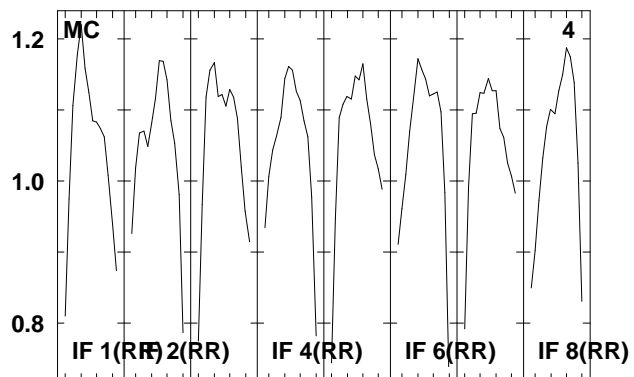
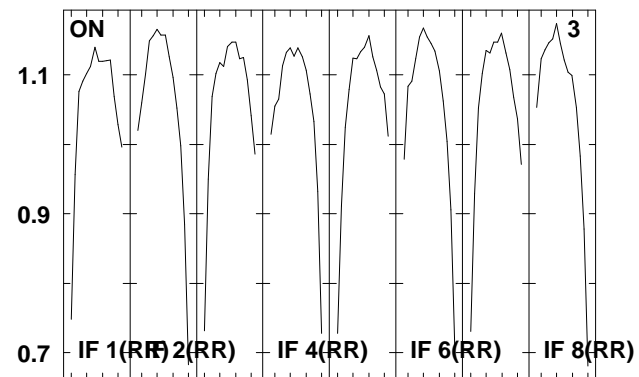
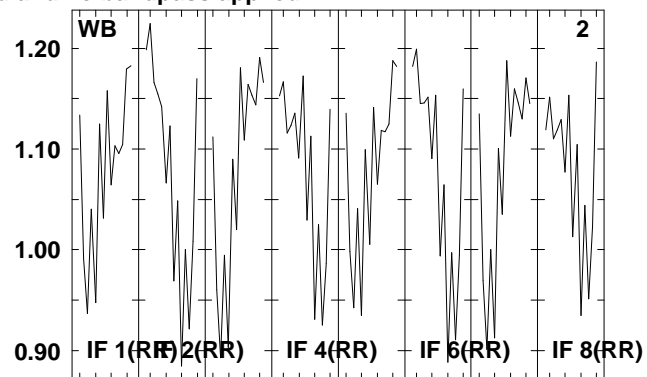
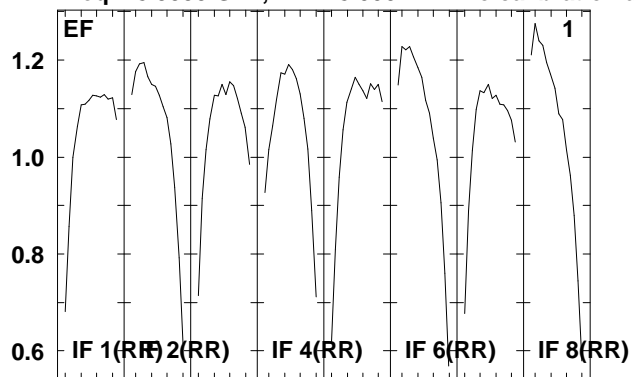

Lower frame: Real Jy  
Total-power spectrum Antenna: \*  
Timerange: 01/00:38:26 to 01/00:41:54

Plot file version 158 created 05-OCT-2009 09:28:41

J1651+01 EH023B 2.UVDATA.1

Freq = 8.3535 GHz, Bw = 8.000 MH No calibration applied and no bandpass applied

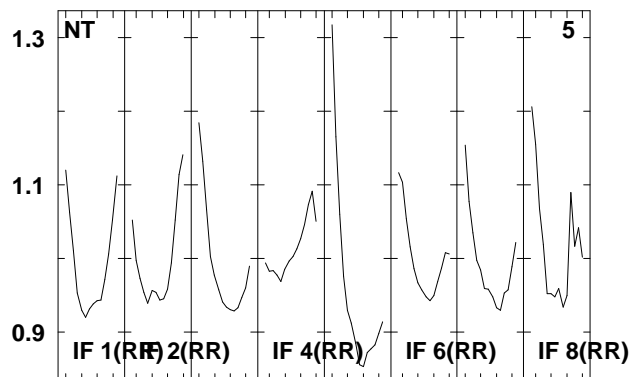
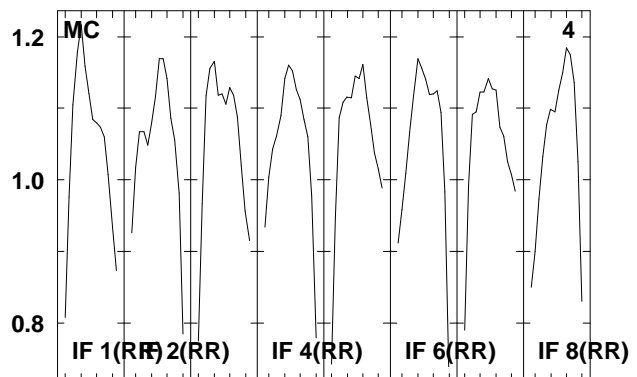
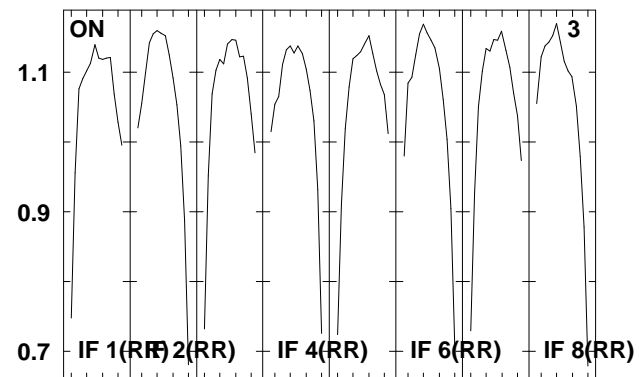
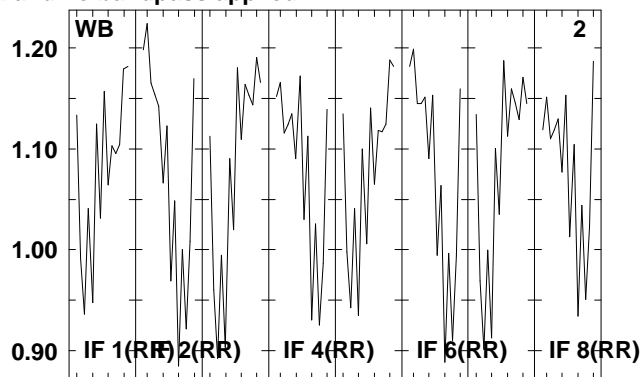
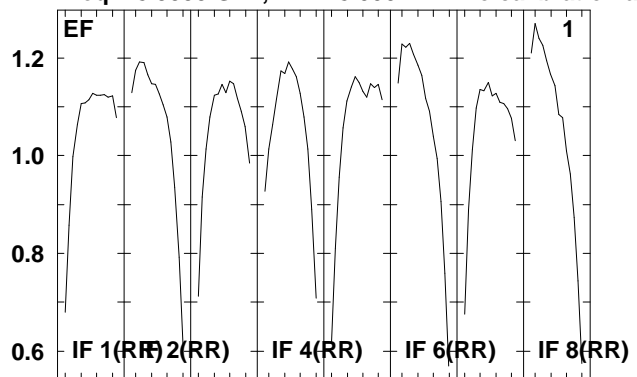

Lower frame: Real Jy  
Total-power spectrum Antenna: \*  
Timerange: 01/00:42:26 to 01/00:43:54

Plot file version 159 created 05-OCT-2009 09:28:41

NGC6240 EH023B 2.UVDATA.1

Freq = 8.3535 GHz, Bw = 8.000 MH No calibration applied and no bandpass applied

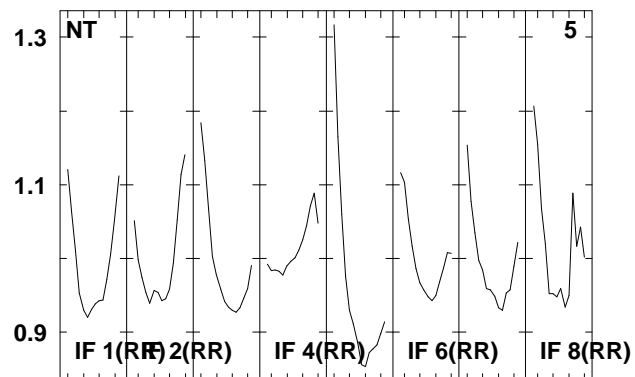
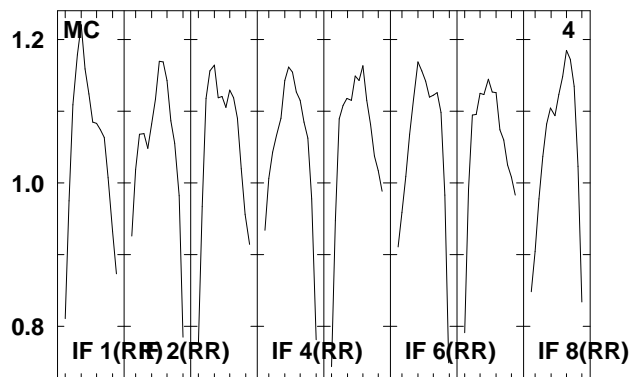
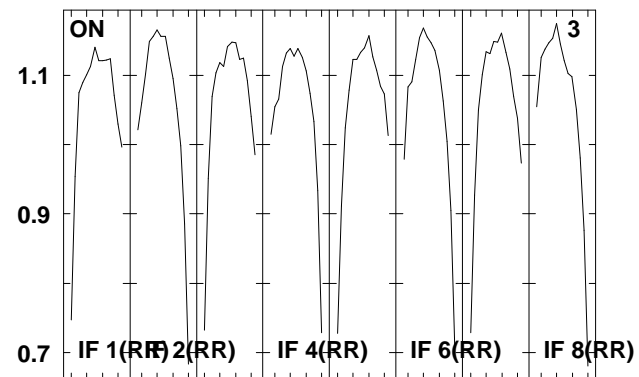
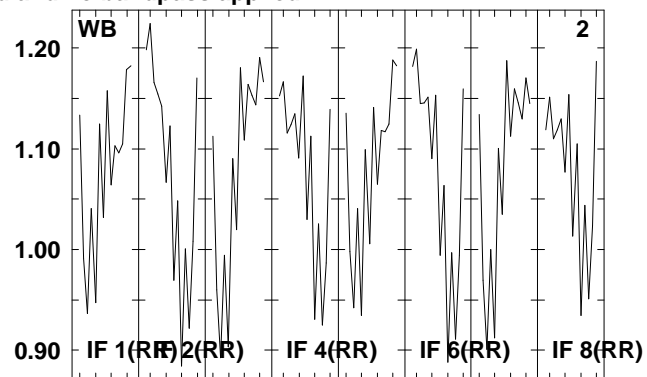
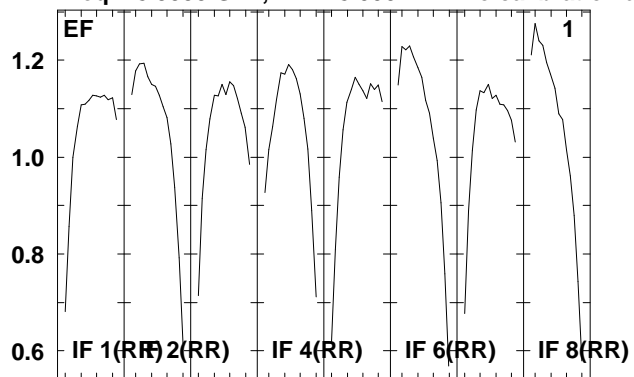

Lower frame: Real Jy  
Total-power spectrum Antenna: \*  
Timerange: 01/00:43:56 to 01/00:47:24

Plot file version 160 created 05-OCT-2009 09:28:41

J1651+01 EH023B 2.UVDATA.1

Freq = 8.3535 GHz, Bw = 8.000 MH No calibration applied and no bandpass applied

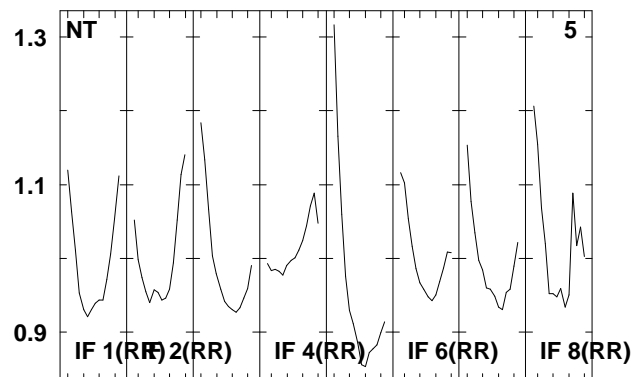
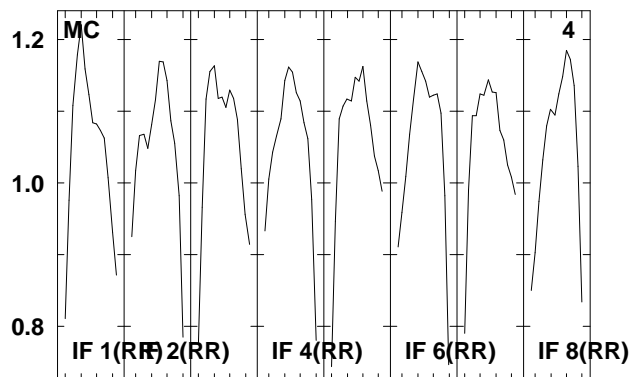
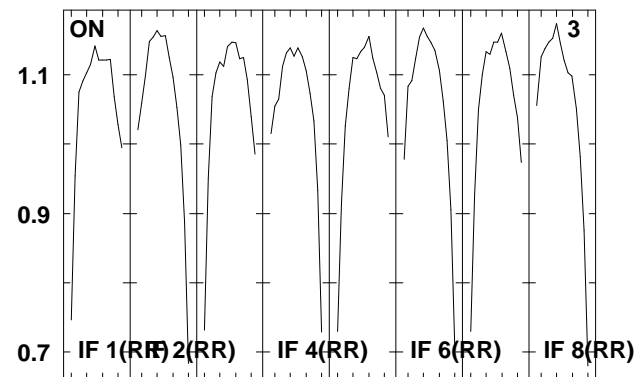
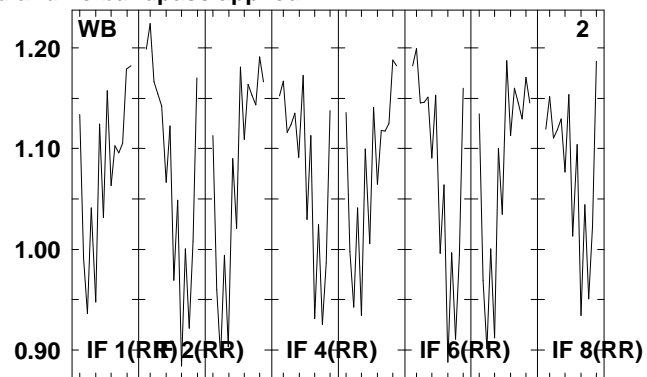
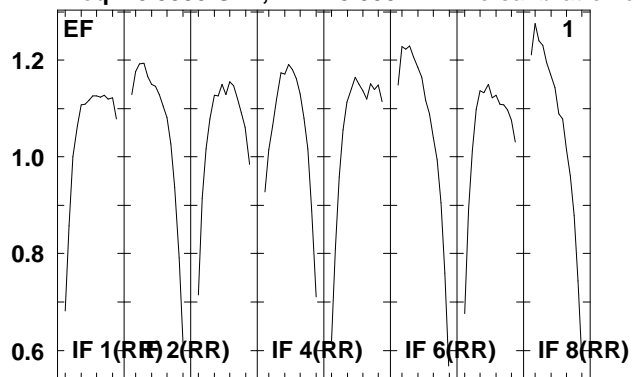

Lower frame: Real Jy  
Total-power spectrum Antenna: \*  
Timerange: 01/00:47:26 to 01/00:48:54



Plot file version 161 created 05-OCT-2009 09:28:41

NGC6240 EH023B 2.UVDATA.1

Freq = 8.3535 GHz, Bw = 8.000 MH No calibration applied and no bandpass applied

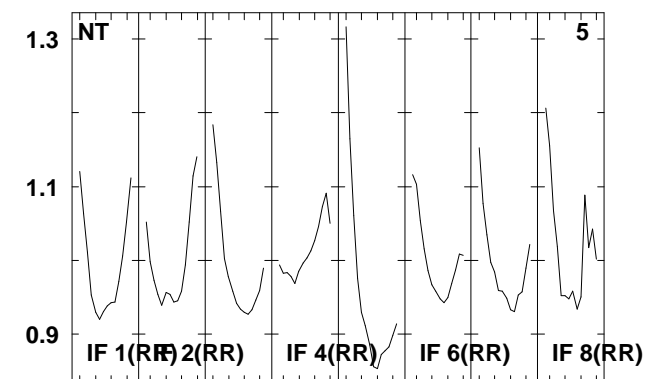
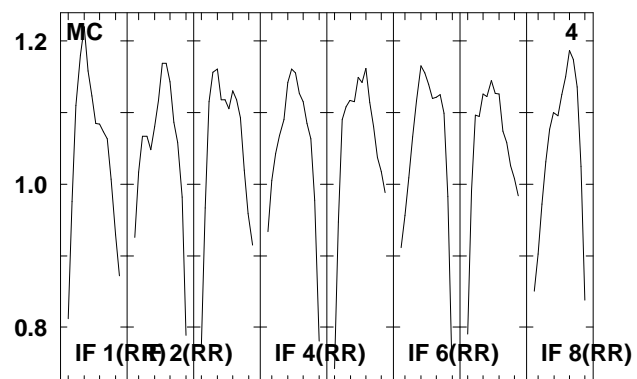
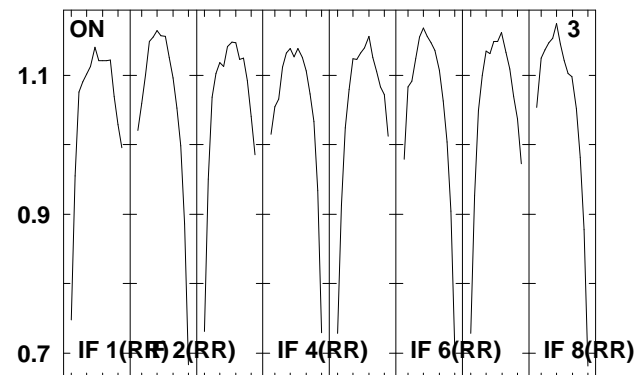
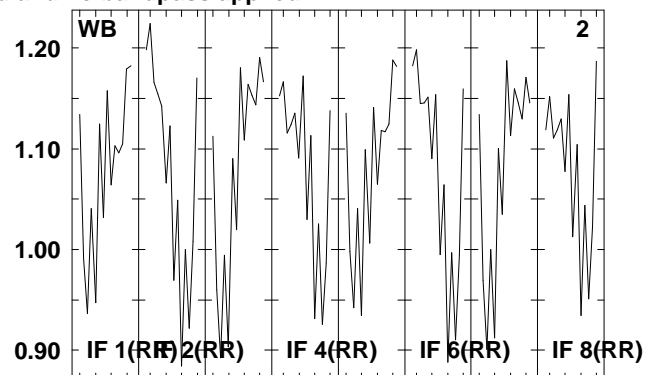
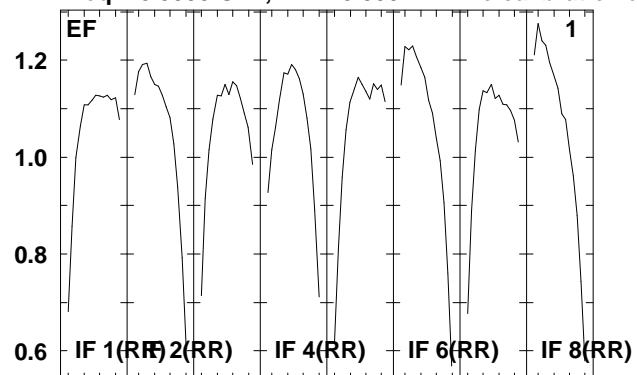

Lower frame: Real Jy  
Total-power spectrum Antenna: \*  
Timerange: 01/00:48:56 to 01/00:52:24

Plot file version 162 created 05-OCT-2009 09:28:42

J1651+01 EH023B 2.UVDATA.1

Freq = 8.3535 GHz, Bw = 8.000 MH No calibration applied and no bandpass applied

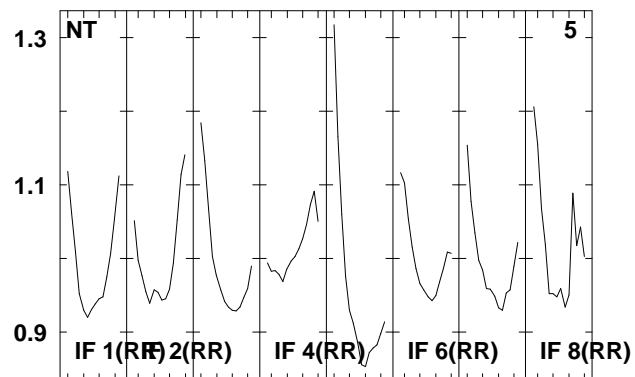
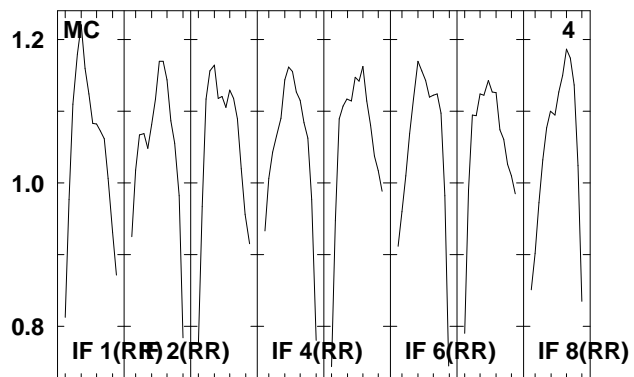
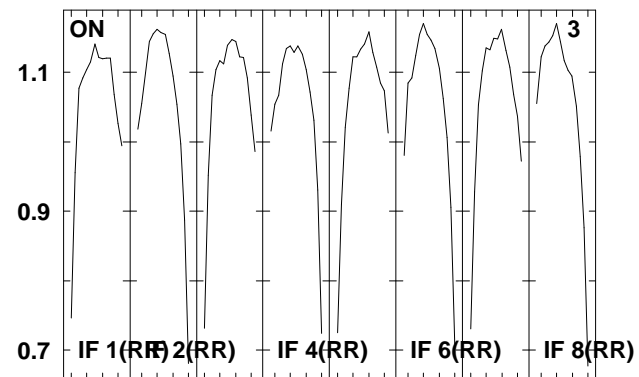
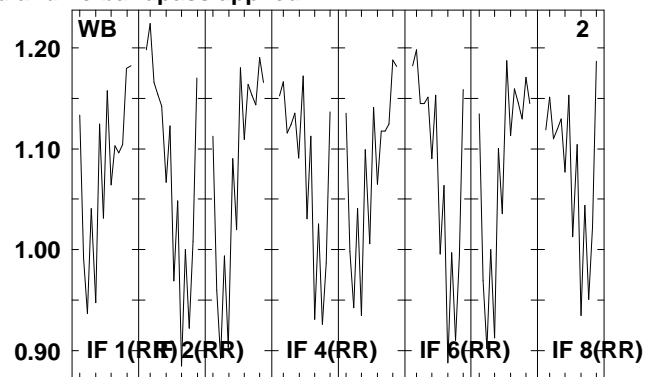
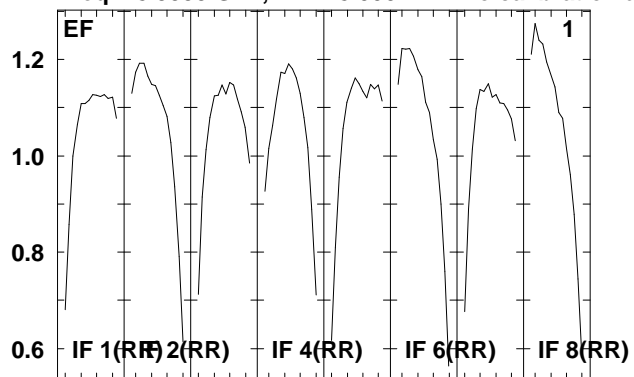

Lower frame: Real Jy  
Total-power spectrum Antenna: \*  
Timerange: 01/00:52:56 to 01/00:54:24

Plot file version 163 created 05-OCT-2009 09:28:42

NGC6240 EH023B 2.UVDATA.1

Freq = 8.3535 GHz, Bw = 8.000 MH No calibration applied and no bandpass applied

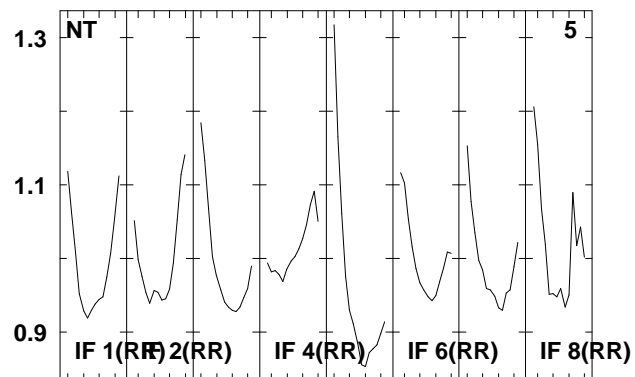
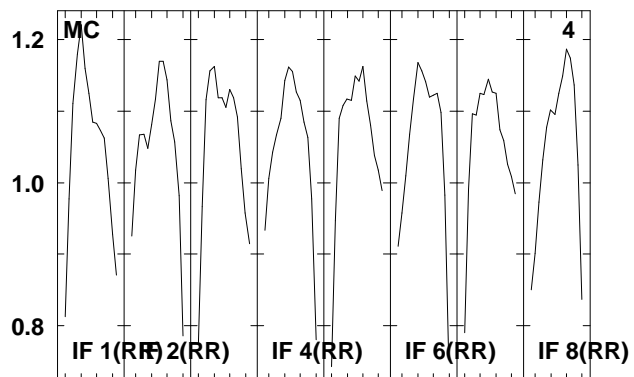
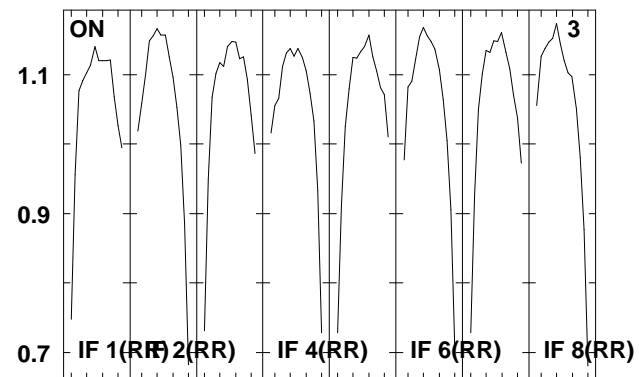
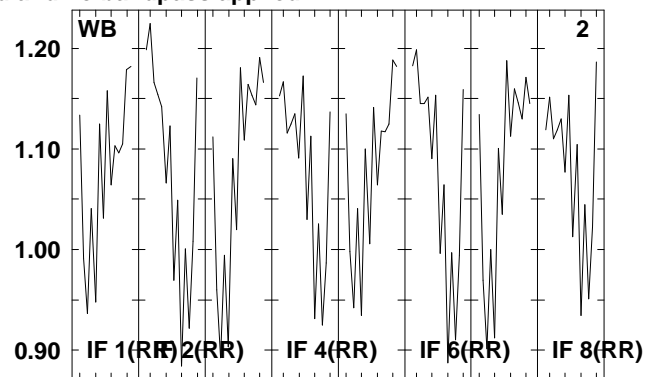
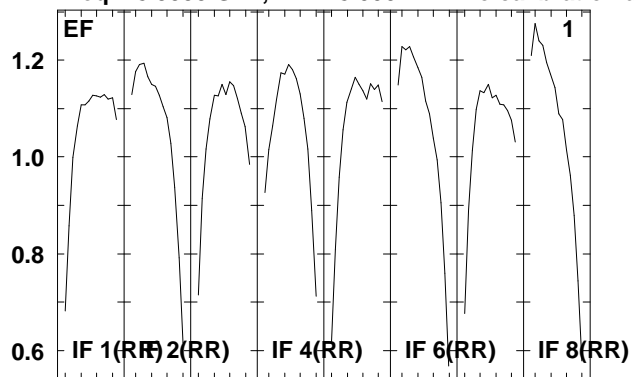

Lower frame: Real Jy  
Total-power spectrum Antenna: \*  
Timerange: 01/00:54:26 to 01/00:57:54

Plot file version 164 created 05-OCT-2009 09:28:42

J1651+01 EH023B 2.UVDATA.1

Freq = 8.3535 GHz, Bw = 8.000 MH No calibration applied and no bandpass applied

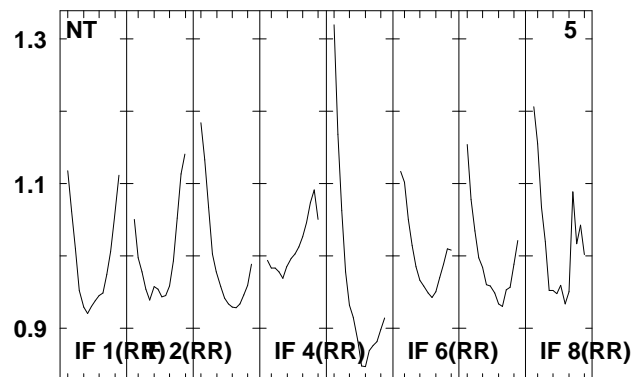
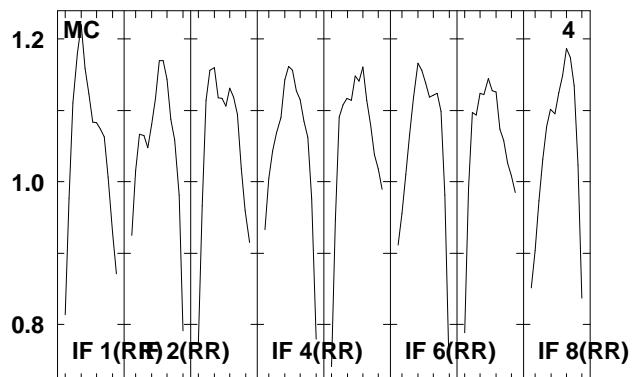
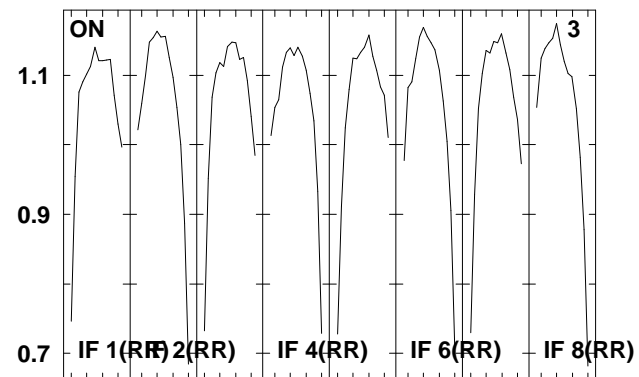
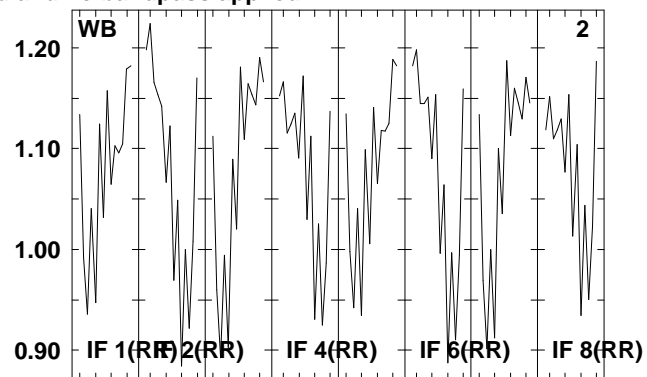
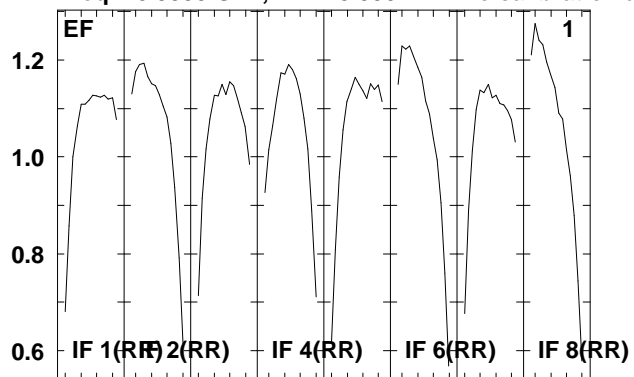

Lower frame: Real Jy  
Total-power spectrum Antenna: \*  
Timerange: 01/00:57:56 to 01/00:59:24

Plot file version 165 created 05-OCT-2009 09:28:42

NGC6240 EH023B 2.UVDATA.1

Freq = 8.3535 GHz, Bw = 8.000 MH No calibration applied and no bandpass applied

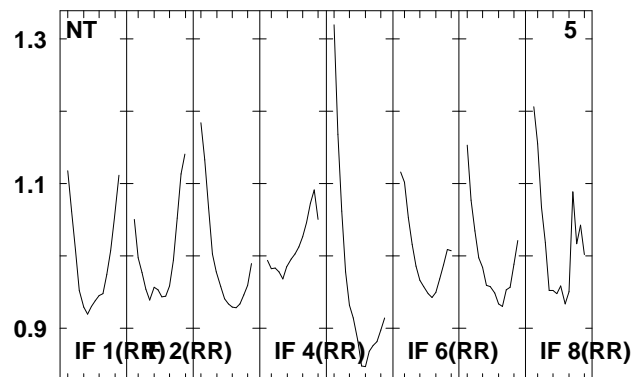
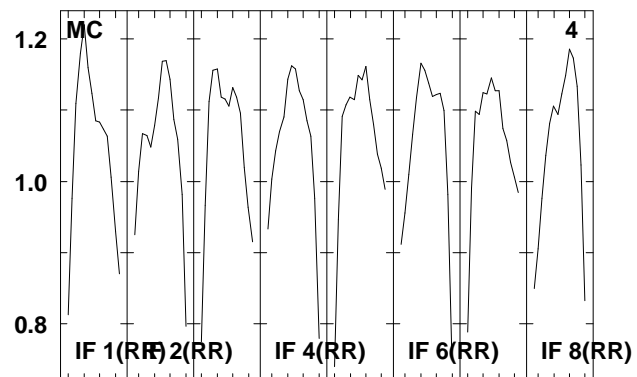
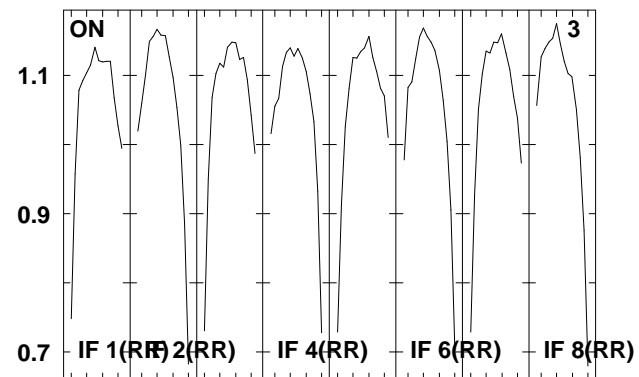
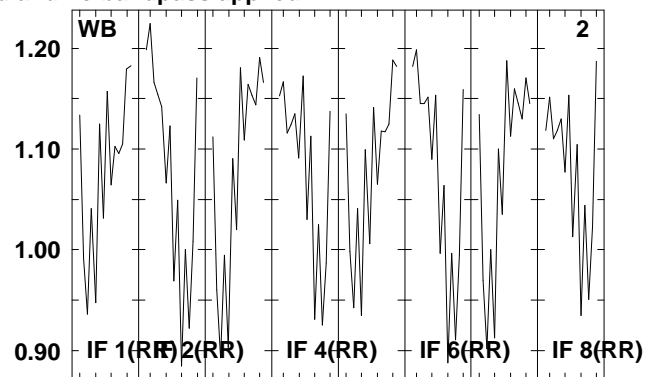
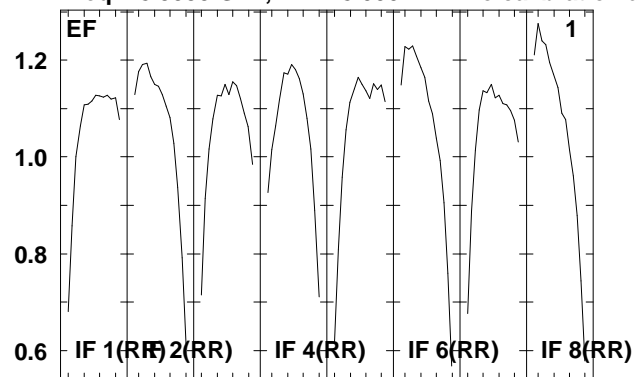

Lower frame: Real Jy  
Total-power spectrum Antenna: \*  
Timerange: 01/00:59:26 to 01/01:02:54

Plot file version 166 created 05-OCT-2009 09:28:42

J1651+01 EH023B 2.UVDATA.1

Freq = 8.3535 GHz, Bw = 8.000 MH No calibration applied and no bandpass applied

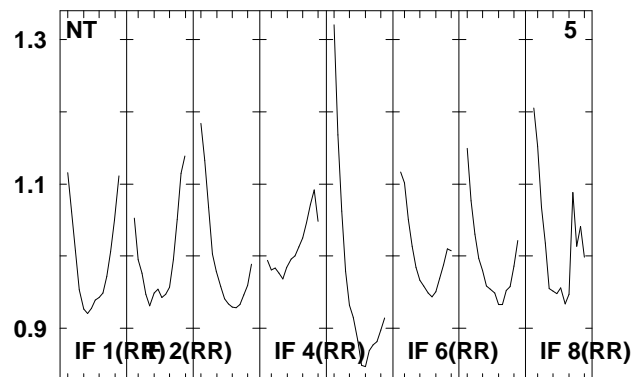
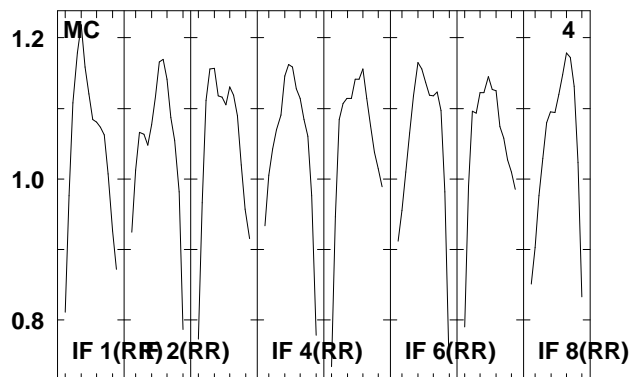
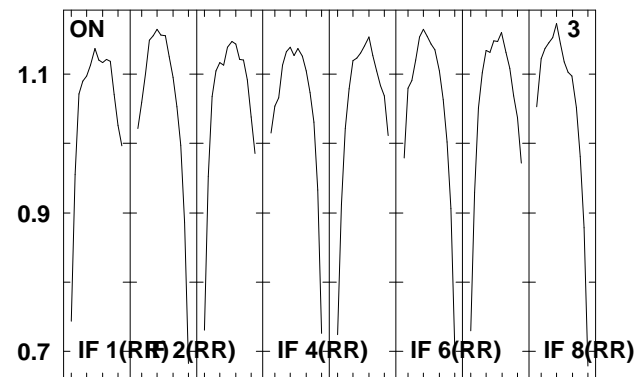
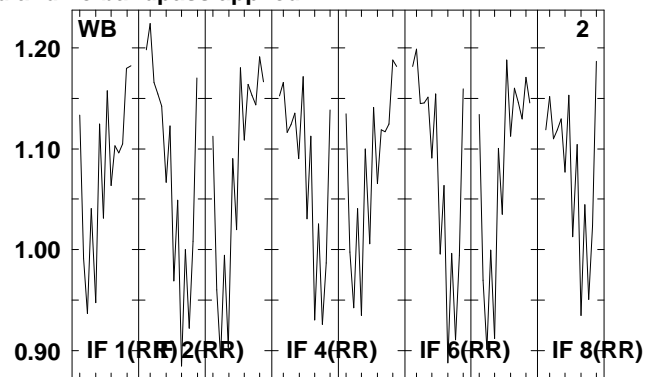
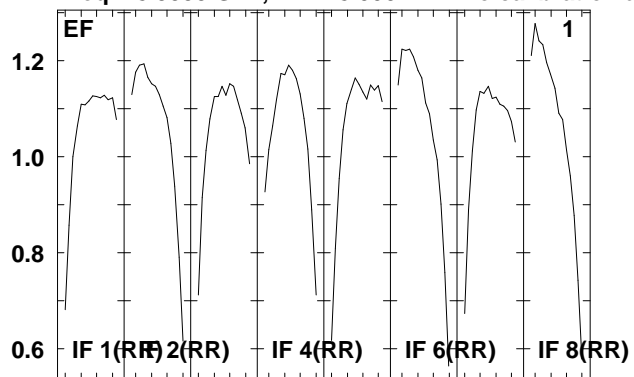

Lower frame: Real Jy  
Total-power spectrum Antenna: \*  
Timerange: 01/01:03:26 to 01/01:04:54

Plot file version 167 created 05-OCT-2009 09:28:42

NGC6240 EH023B 2.UVDATA.1

Freq = 8.3535 GHz, Bw = 8.000 MH No calibration applied and no bandpass applied

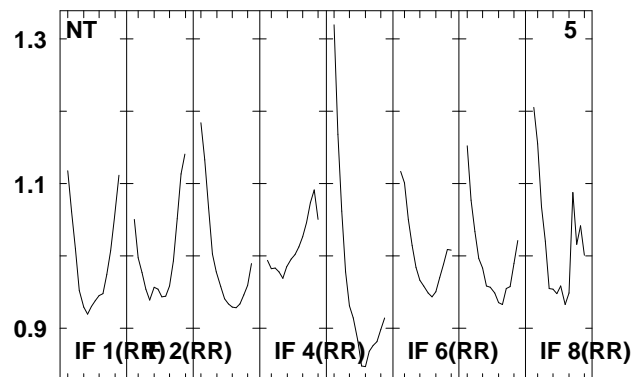
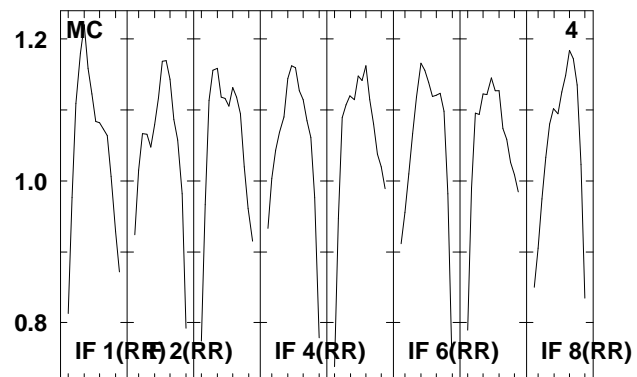
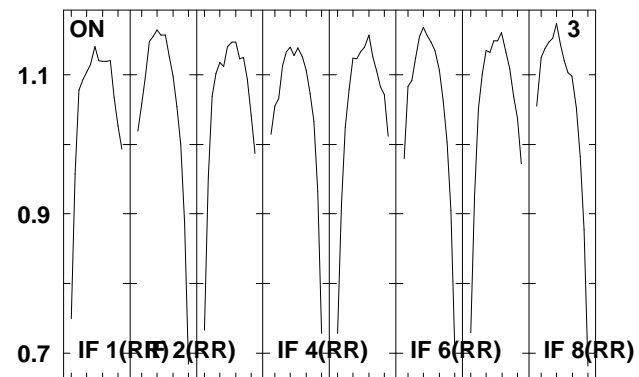
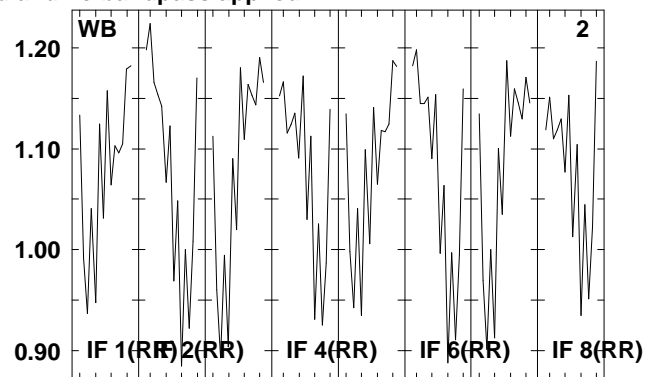
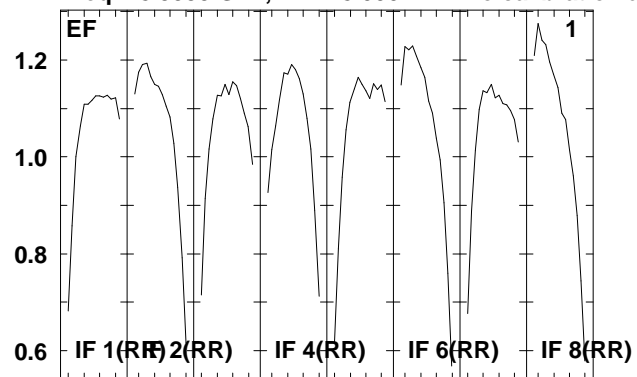

Lower frame: Real Jy  
Total-power spectrum Antenna: \*  
Timerange: 01/01:04:56 to 01/01:08:24

Plot file version 168 created 05-OCT-2009 09:28:42

J1651+01 EH023B 2.UVDATA.1

Freq = 8.3535 GHz, Bw = 8.000 MH No calibration applied and no bandpass applied

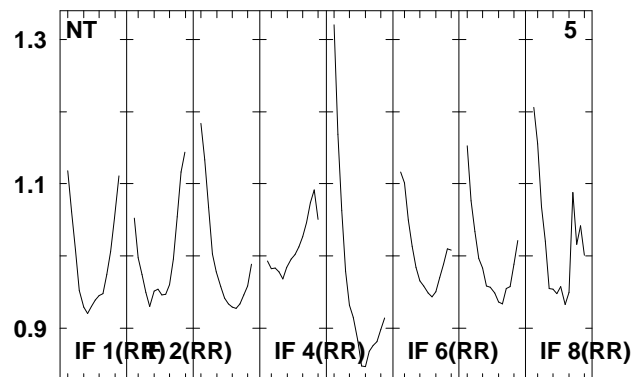
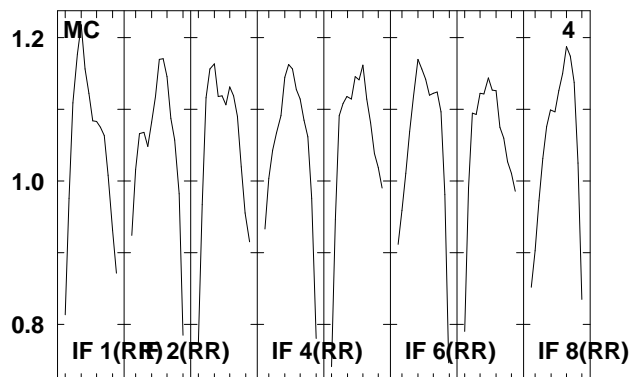
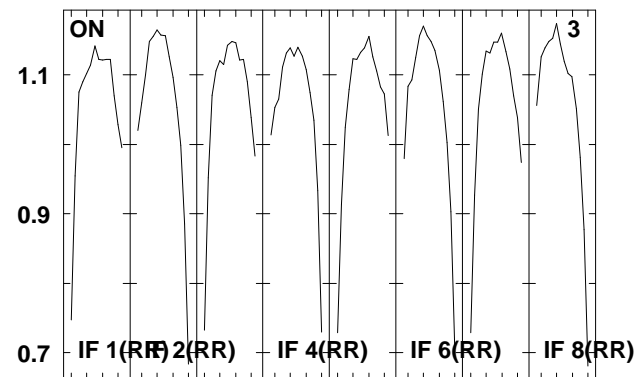
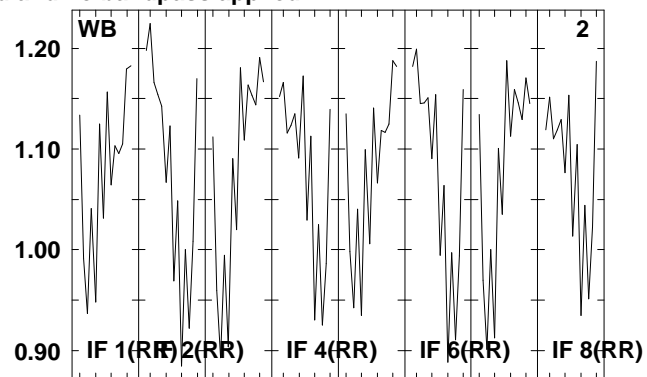
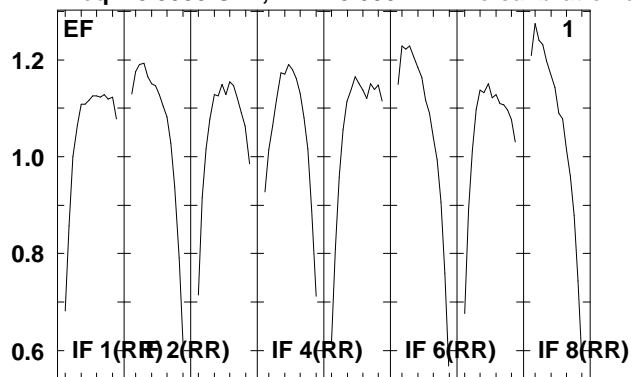

Lower frame: Real Jy  
Total-power spectrum Antenna: \*  
Timerange: 01/01:08:26 to 01/01:09:54



Plot file version 169 created 05-OCT-2009 09:28:42

NGC6240 EH023B 2.UVDATA.1

Freq = 8.3535 GHz, Bw = 8.000 MH No calibration applied and no bandpass applied

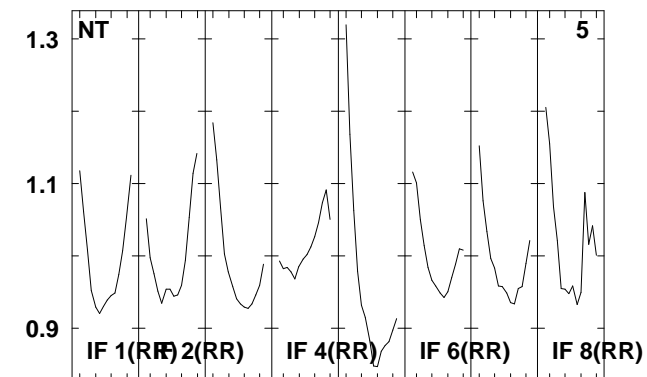
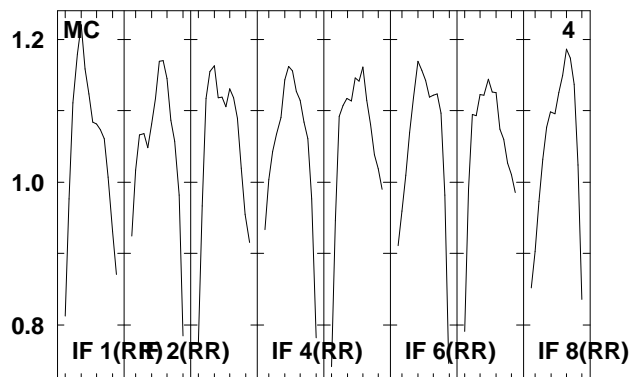
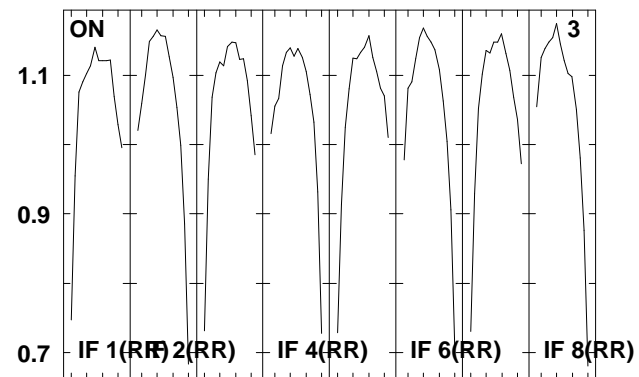
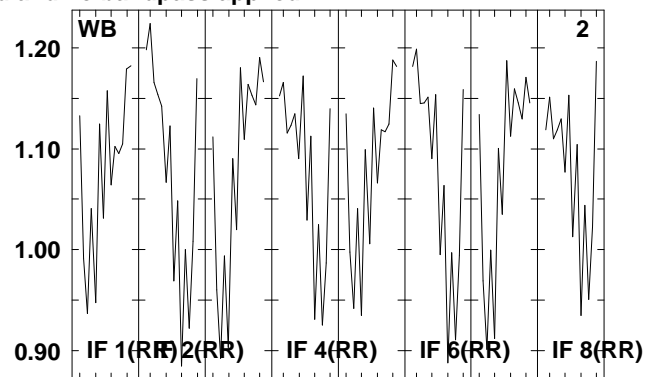
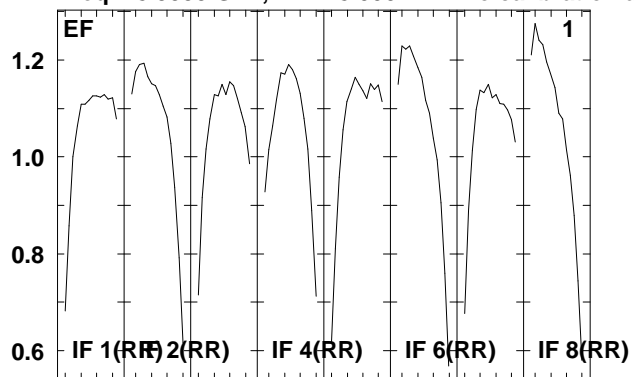

Lower frame: Real Jy  
Total-power spectrum Antenna: \*  
Timerange: 01/01:09:56 to 01/01:13:24

Plot file version 170 created 05-OCT-2009 09:28:43

J1651+01 EH023B 2.UVDATA.1

Freq = 8.3535 GHz, Bw = 8.000 MH No calibration applied and no bandpass applied

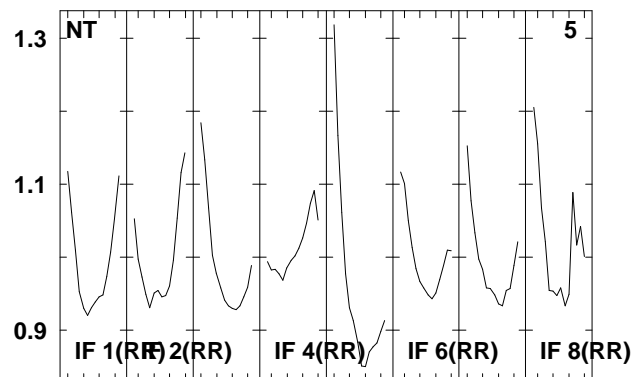
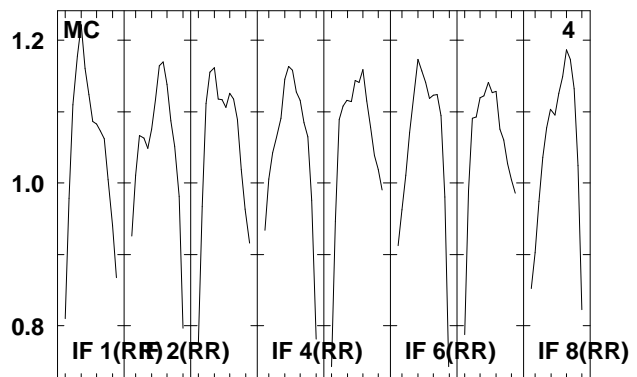
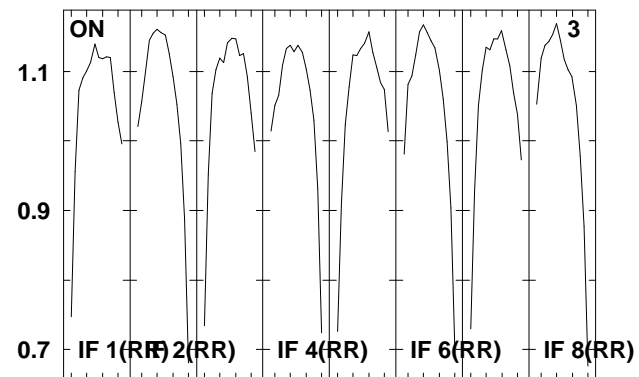
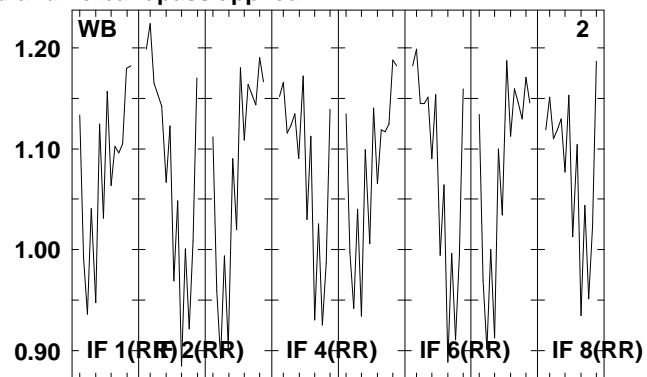
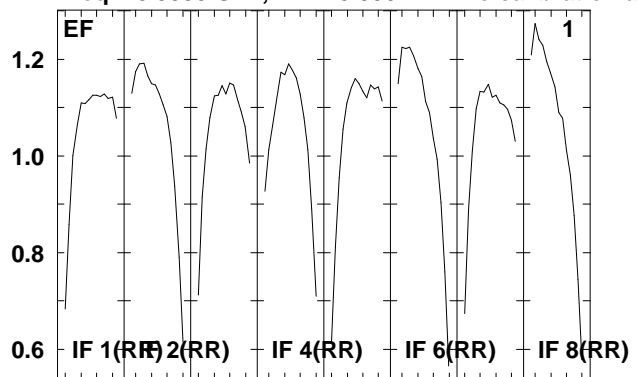

Lower frame: Real Jy  
Total-power spectrum Antenna: \*  
Timerange: 01/01:13:56 to 01/01:15:24

Plot file version 171 created 05-OCT-2009 09:28:43

NGC6240 EH023B 2.UVDATA.1

Freq = 8.3535 GHz, Bw = 8.000 MH No calibration applied and no bandpass applied

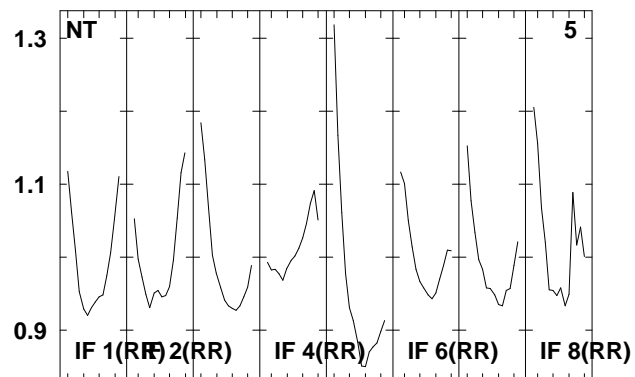
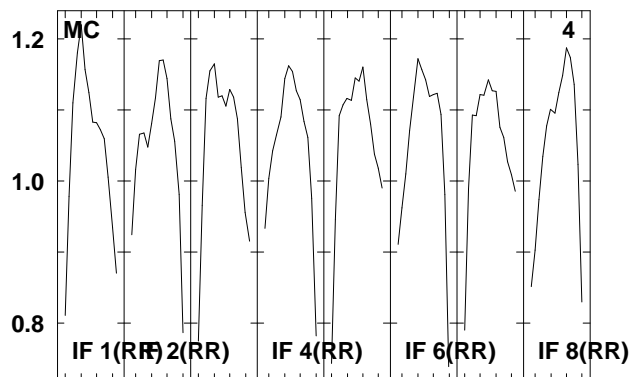
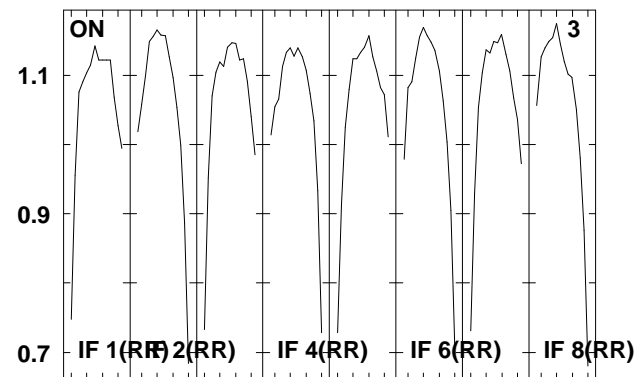
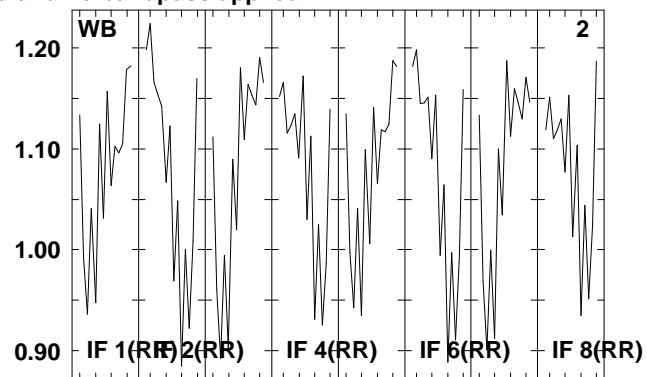
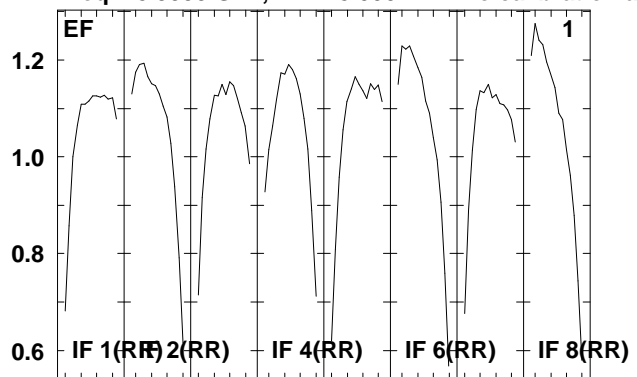

Lower frame: Real Jy  
Total-power spectrum Antenna: \*  
Timerange: 01/01:15:26 to 01/01:18:54

Plot file version 172 created 05-OCT-2009 09:28:43

J1651+01 EH023B 2.UVDATA.1

Freq = 8.3535 GHz, Bw = 8.000 MH No calibration applied and no bandpass applied

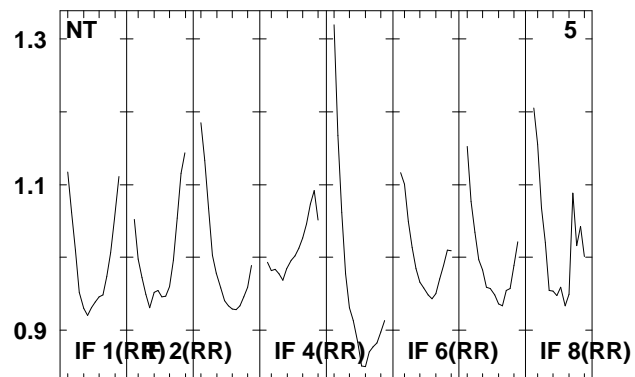
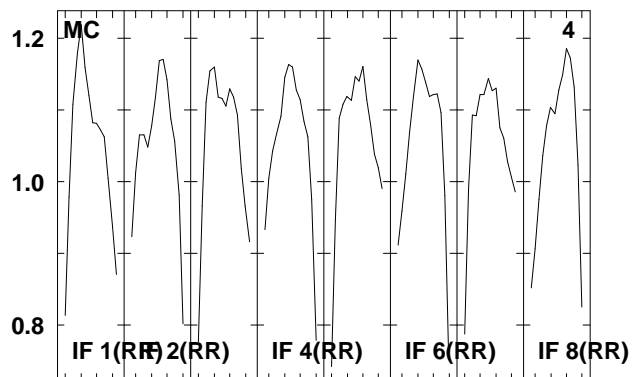
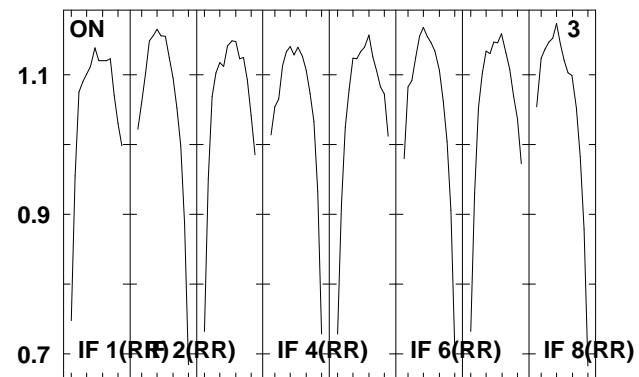
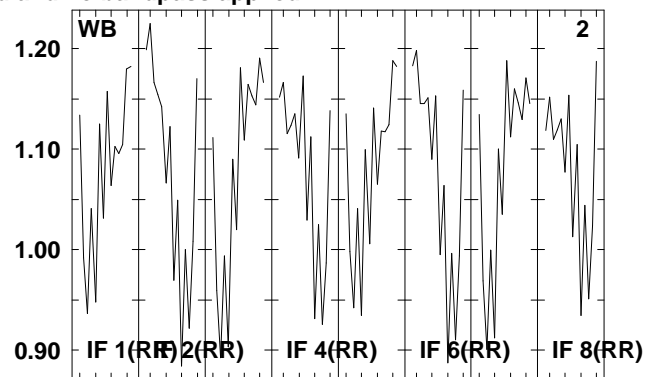
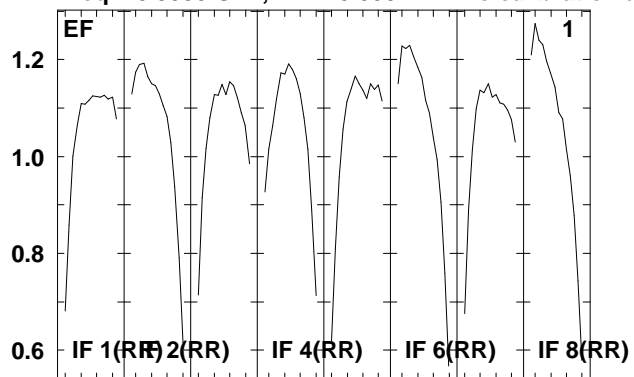

Lower frame: Real Jy  
Total-power spectrum Antenna: \*  
Timerange: 01/01:18:56 to 01/01:20:24

Plot file version 173 created 05-OCT-2009 09:28:43

NGC6240 EH023B 2.UVDATA.1

Freq = 8.3535 GHz, Bw = 8.000 MH No calibration applied and no bandpass applied

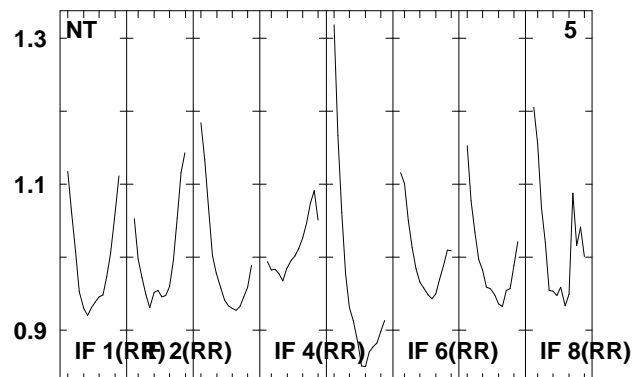
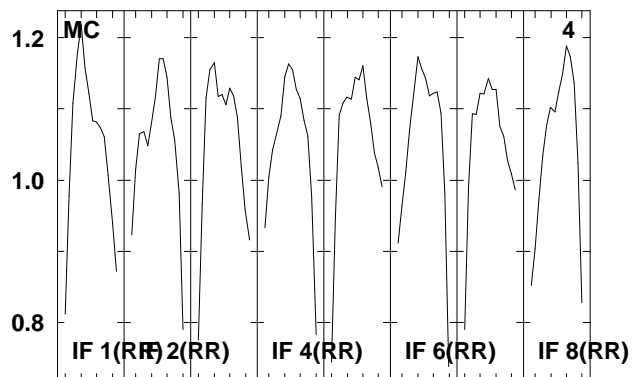
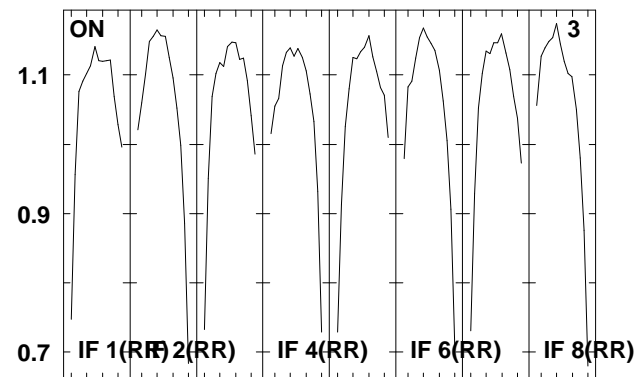
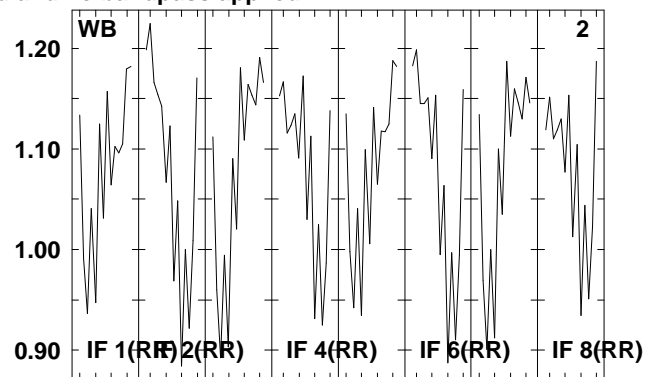
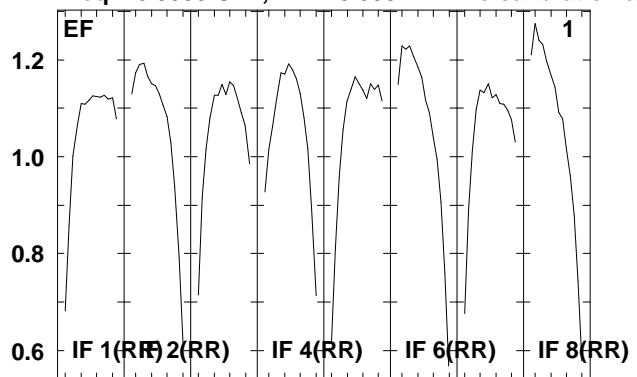

Lower frame: Real Jy  
Total-power spectrum Antenna: \*  
Timerange: 01/01:20:26 to 01/01:23:54

Plot file version 174 created 05-OCT-2009 09:28:43

J1651+01 EH023B 2.UVDATA.1

Freq = 8.3535 GHz, Bw = 8.000 MH No calibration applied and no bandpass applied

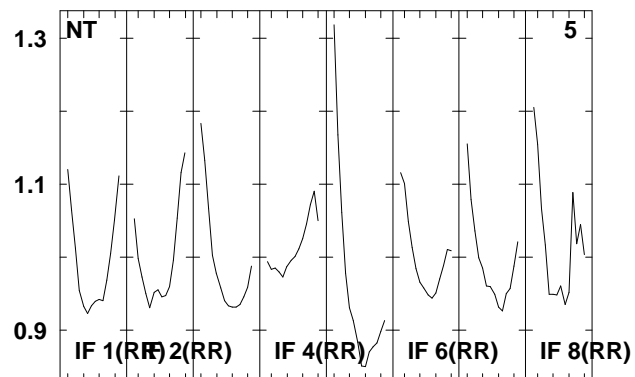
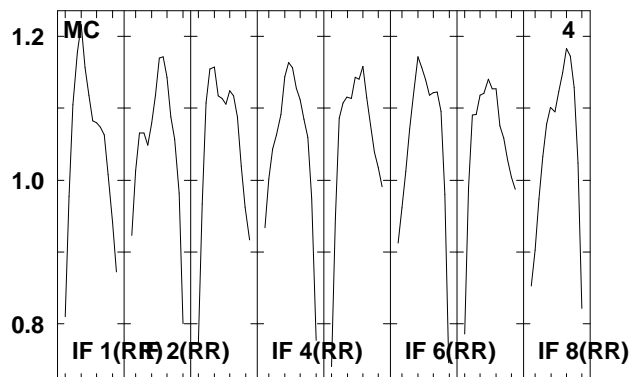
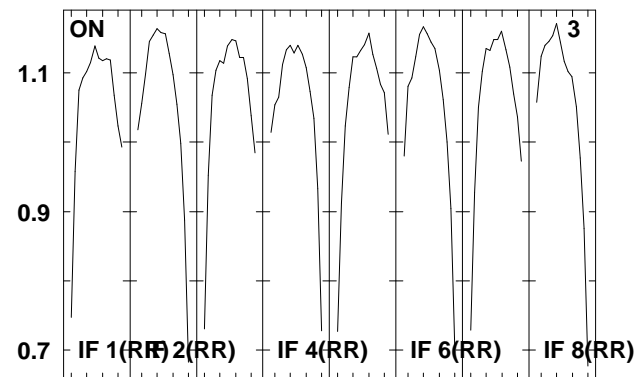
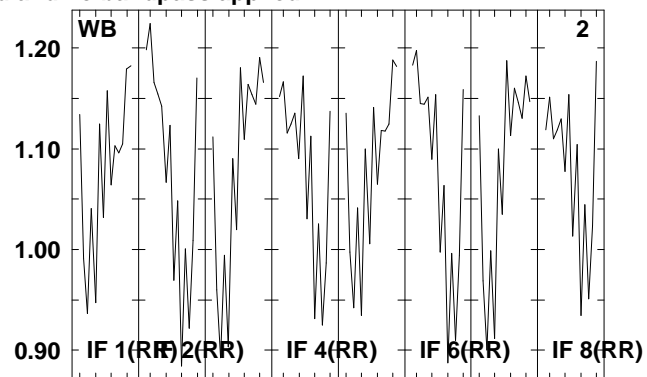
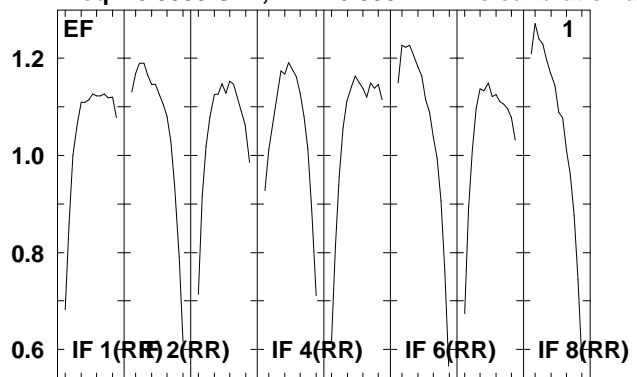

Lower frame: Real Jy  
Total-power spectrum Antenna: \*  
Timerange: 01/01:24:26 to 01/01:25:54

Plot file version 175 created 05-OCT-2009 09:28:43

NGC6240 EH023B 2.UVDATA.1

Freq = 8.3535 GHz, Bw = 8.000 MH No calibration applied and no bandpass applied

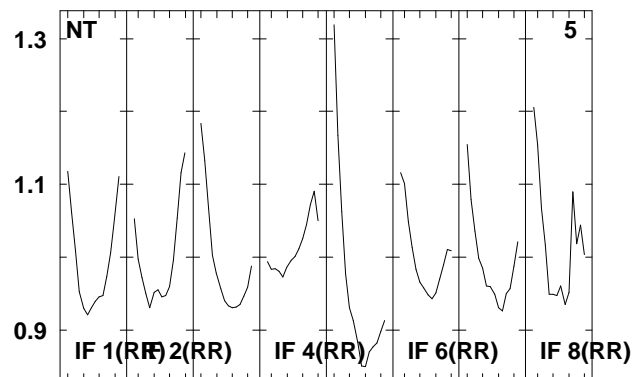
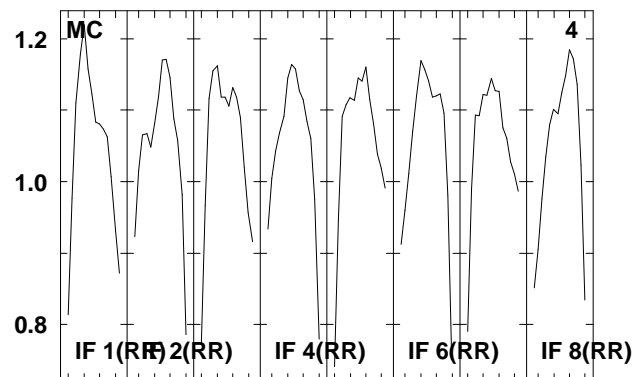
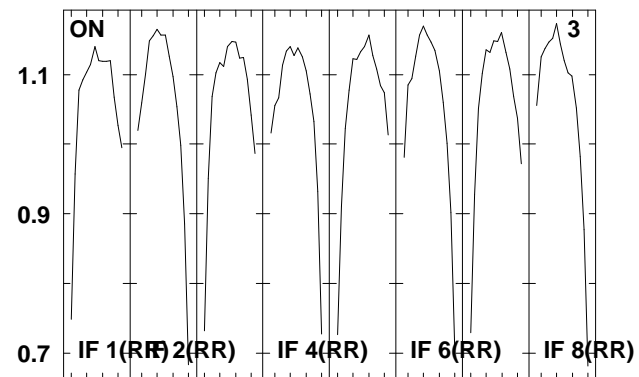
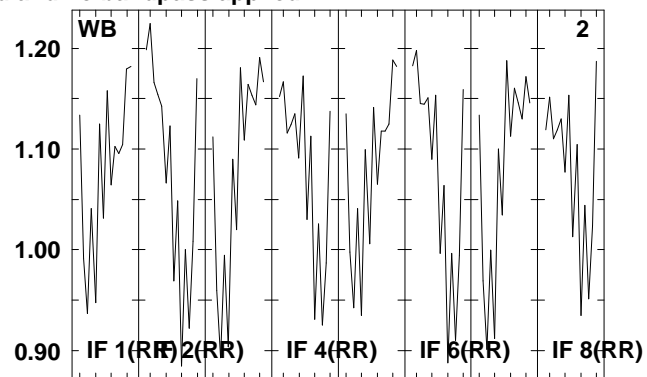
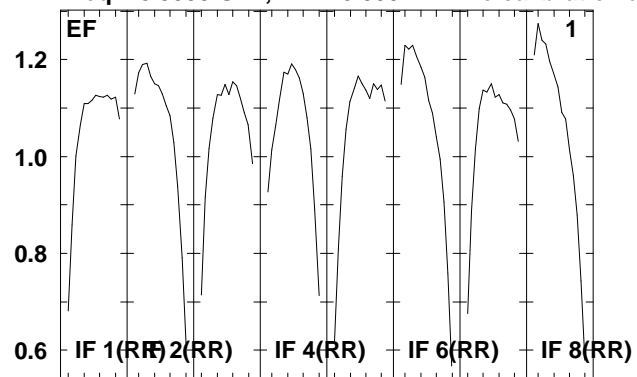

Lower frame: Real Jy  
Total-power spectrum Antenna: \*  
Timerange: 01/01:25:56 to 01/01:29:24

Plot file version 176 created 05-OCT-2009 09:28:43

J1651+01 EH023B 2.UVDATA.1

Freq = 8.3535 GHz, Bw = 8.000 MH No calibration applied and no bandpass applied

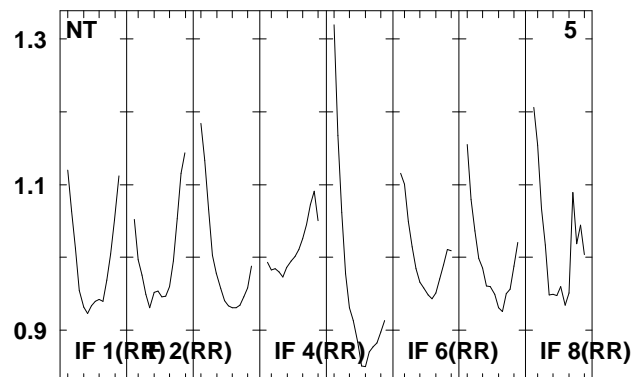
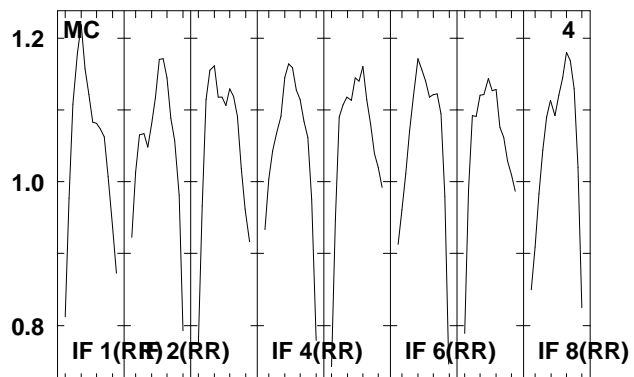
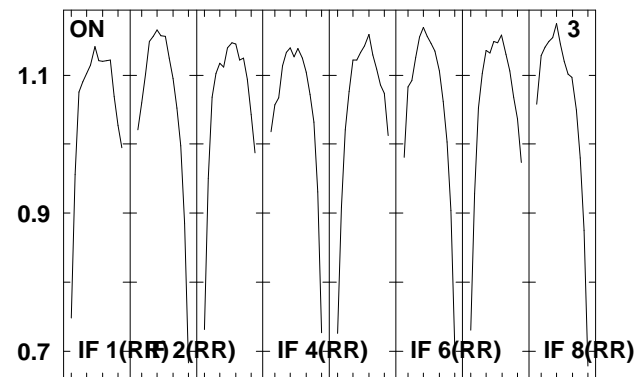
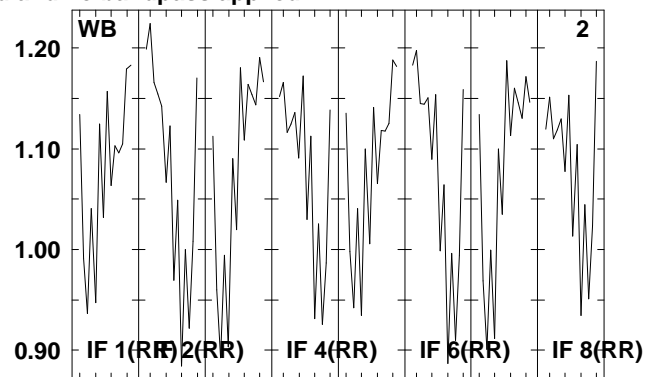
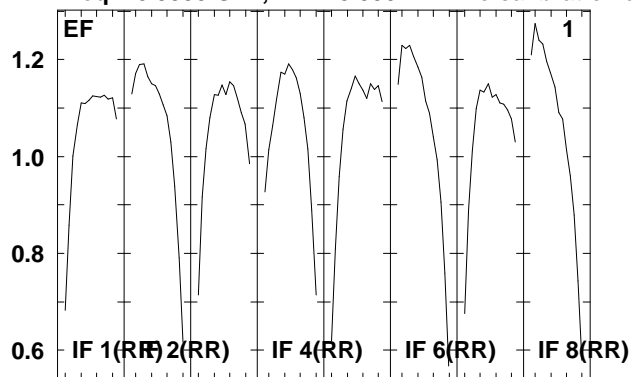

Lower frame: Real Jy  
Total-power spectrum Antenna: \*  
Timerange: 01/01:29:26 to 01/01:30:54



Plot file version 177 created 05-OCT-2009 09:28:44

NGC6240 EH023B 2.UVDATA.1

Freq = 8.3535 GHz, Bw = 8.000 MH No calibration applied and no bandpass applied

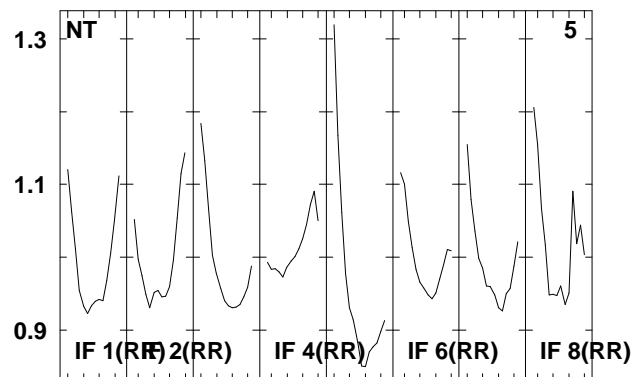
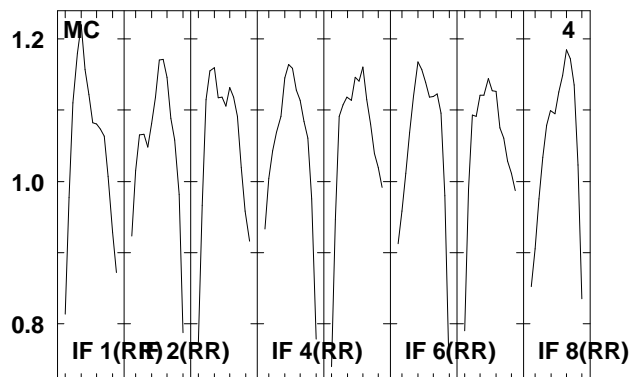
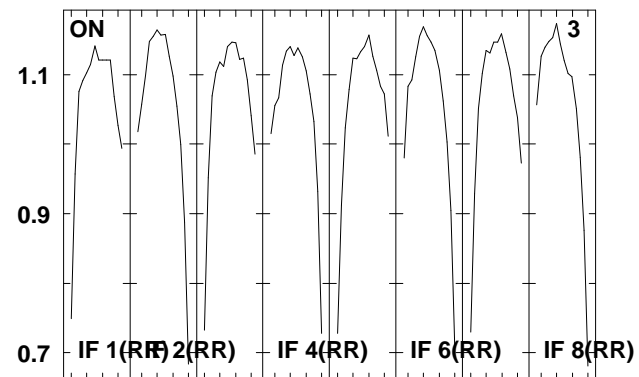
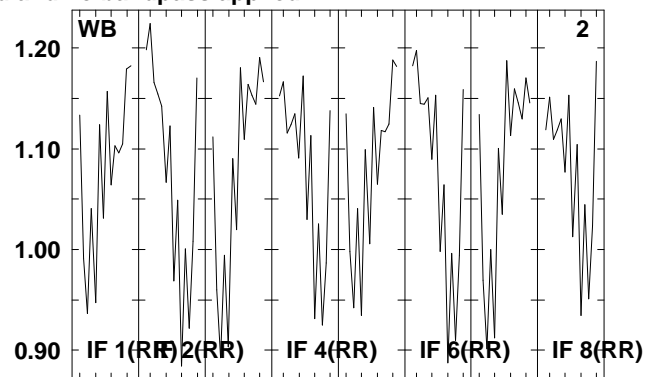
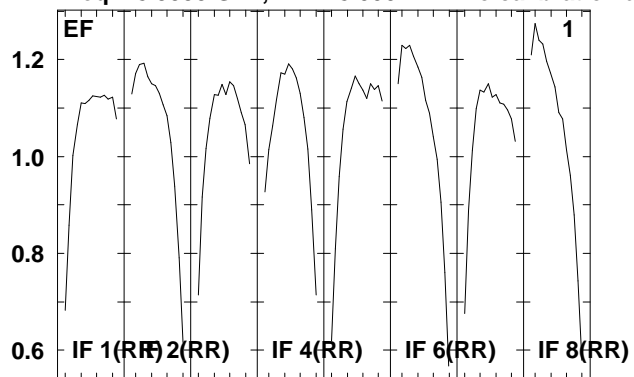

Lower frame: Real Jy  
Total-power spectrum Antenna: \*  
Timerange: 01/01:30:56 to 01/01:34:24

Plot file version 178 created 05-OCT-2009 09:28:44

J1651+01 EH023B 2.UVDATA.1

Freq = 8.3535 GHz, Bw = 8.000 MH No calibration applied and no bandpass applied

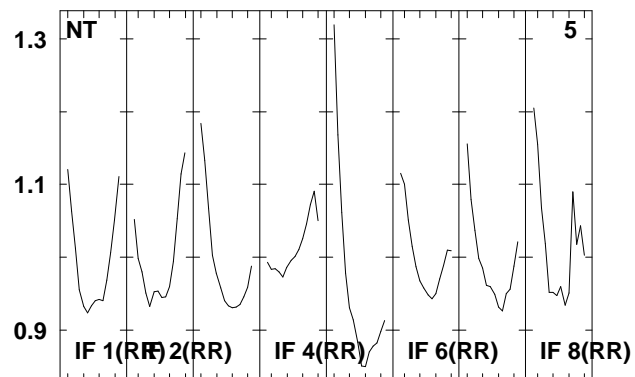
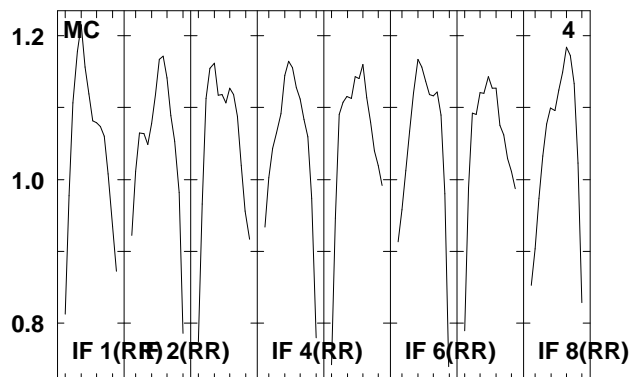
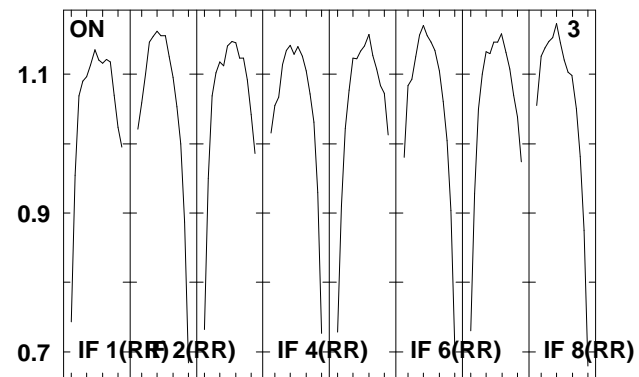
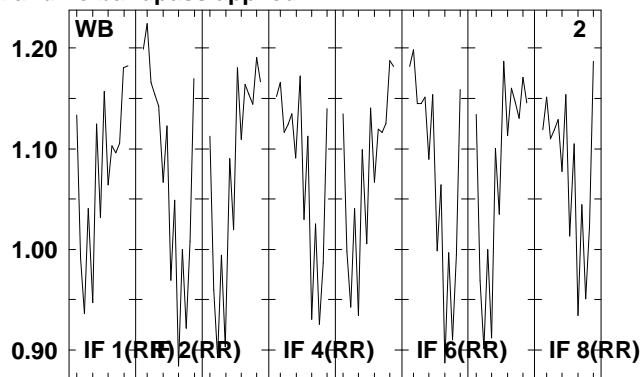
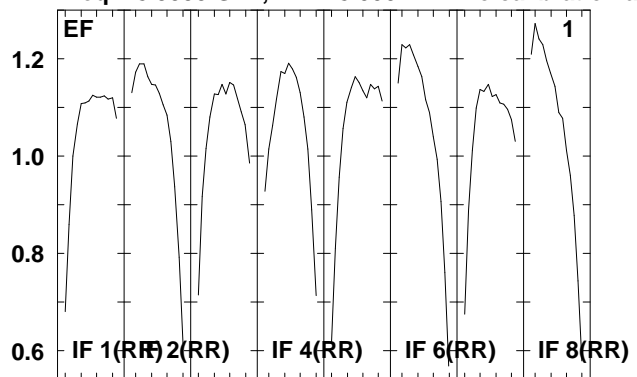

Lower frame: Real Jy  
Total-power spectrum Antenna: \*  
Timerange: 01/01:34:56 to 01/01:36:24

Plot file version 179 created 05-OCT-2009 09:28:44

NGC6240 EH023B 2.UVDATA.1

Freq = 8.3535 GHz, Bw = 8.000 MH No calibration applied and no bandpass applied

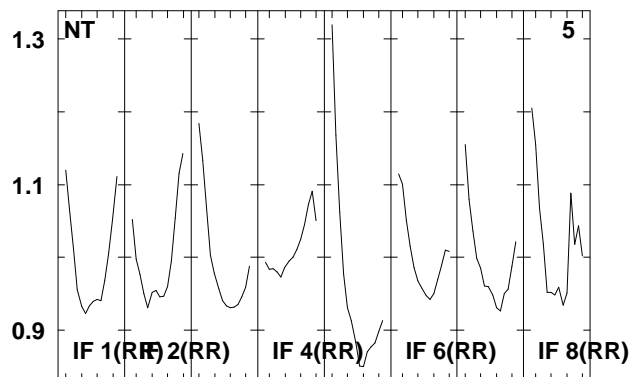
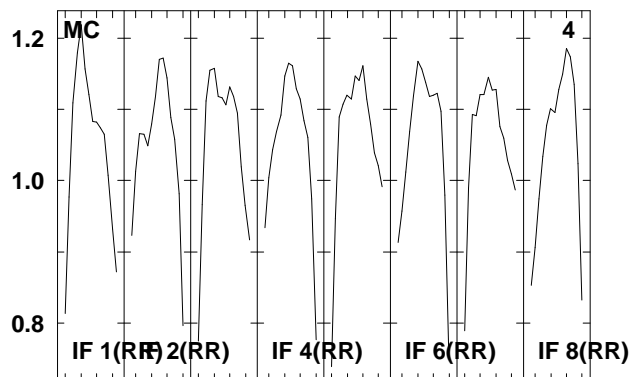
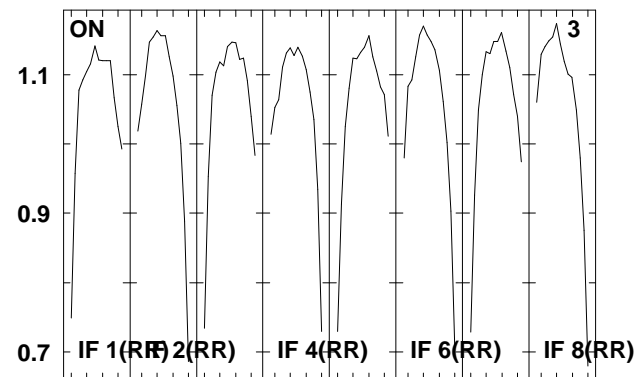
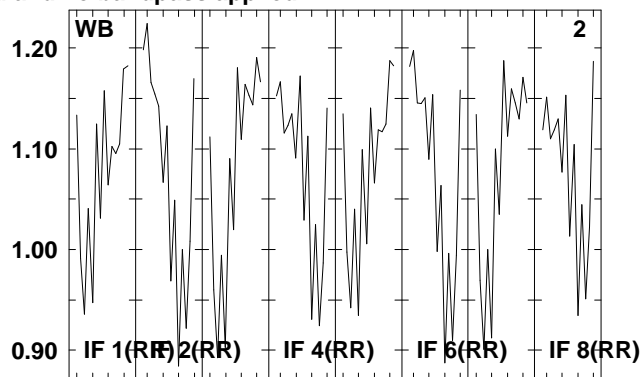
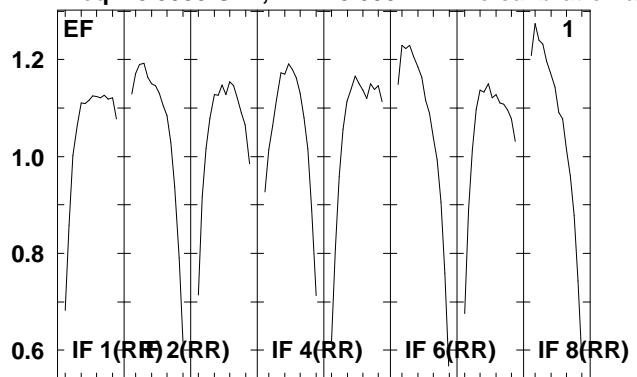

Lower frame: Real Jy  
Total-power spectrum Antenna: \*  
Timerange: 01/01:36:26 to 01/01:39:54

Plot file version 180 created 05-OCT-2009 09:28:44

J1651+01 EH023B 2.UVDATA.1

Freq = 8.3535 GHz, Bw = 8.000 MH No calibration applied and no bandpass applied

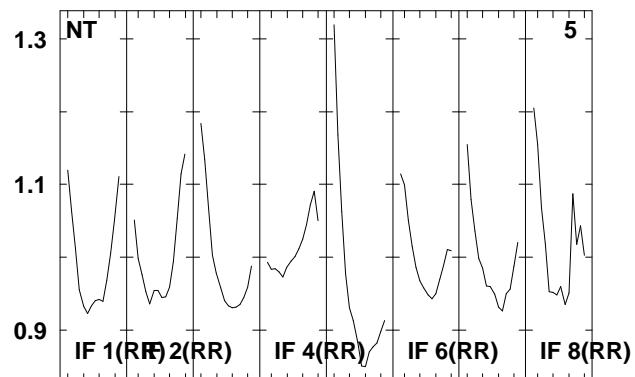
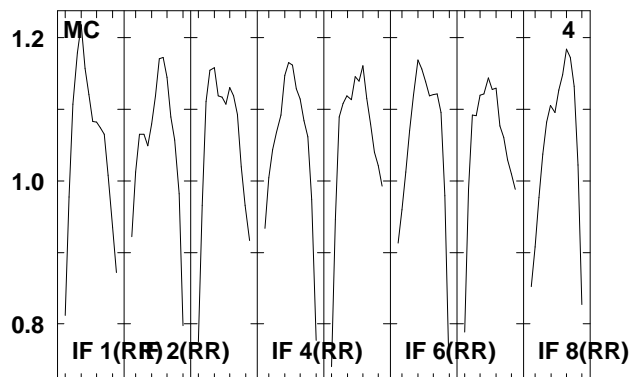
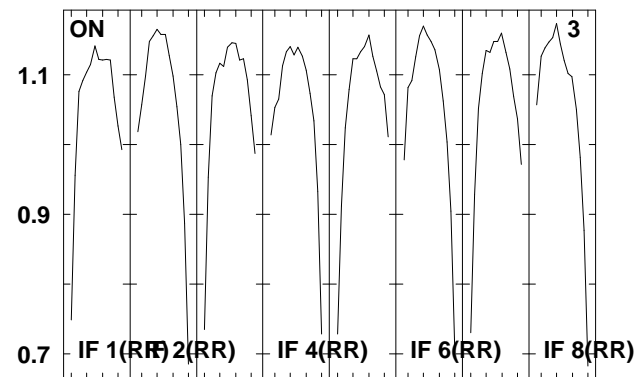
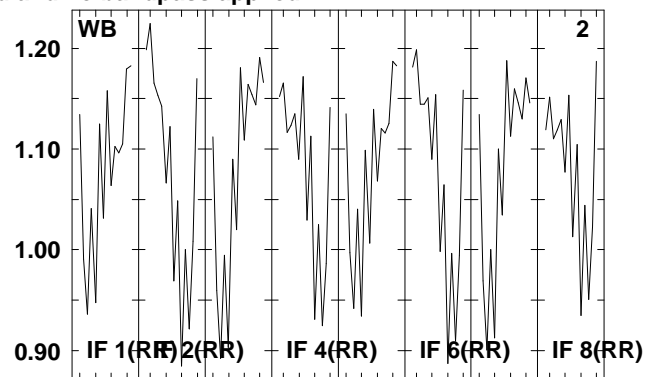
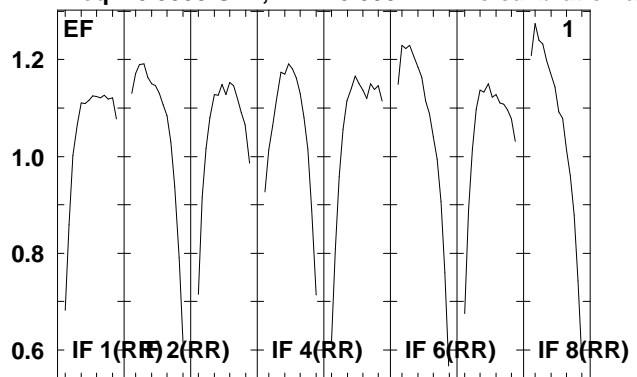

Lower frame: Real Jy  
Total-power spectrum Antenna: \*  
Timerange: 01/01:39:56 to 01/01:41:24

Plot file version 181 created 05-OCT-2009 09:28:44

NGC6240 EH023B 2.UVDATA.1

Freq = 8.3535 GHz, Bw = 8.000 MH No calibration applied and no bandpass applied

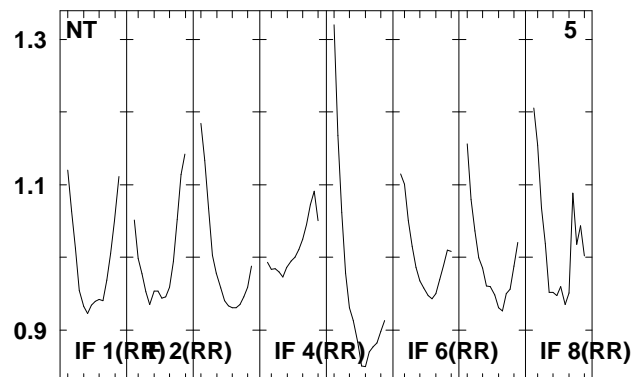
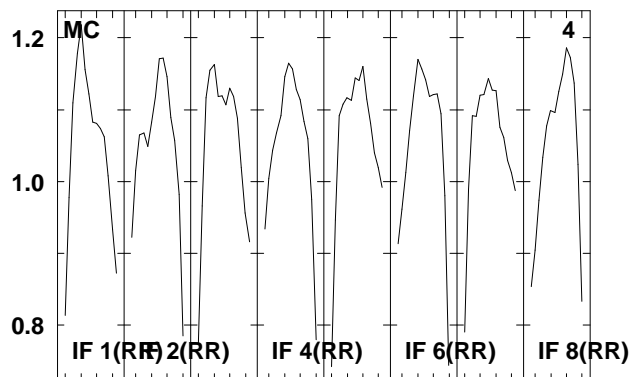
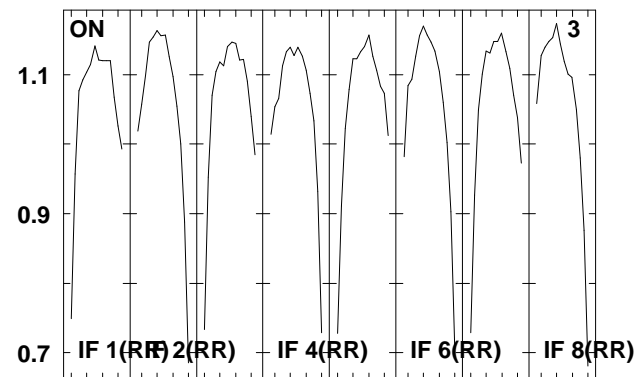
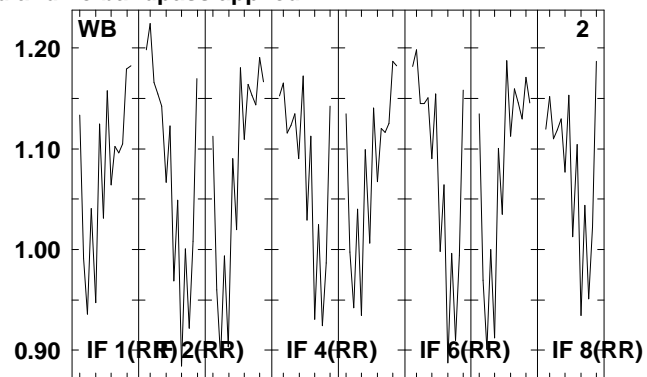
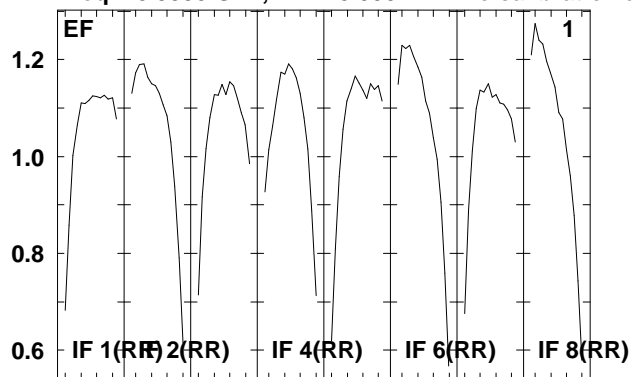

Lower frame: Real Jy  
Total-power spectrum Antenna: \*  
Timerange: 01/01:41:26 to 01/01:44:54

Plot file version 182 created 05-OCT-2009 09:28:45

J1651+01 EH023B 2.UVDATA.1

Freq = 8.3535 GHz, Bw = 8.000 MH No calibration applied and no bandpass applied

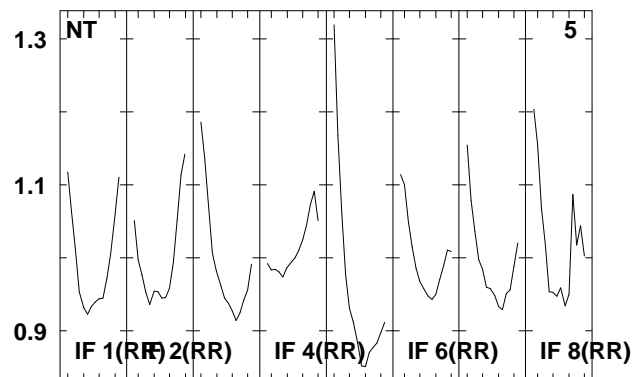
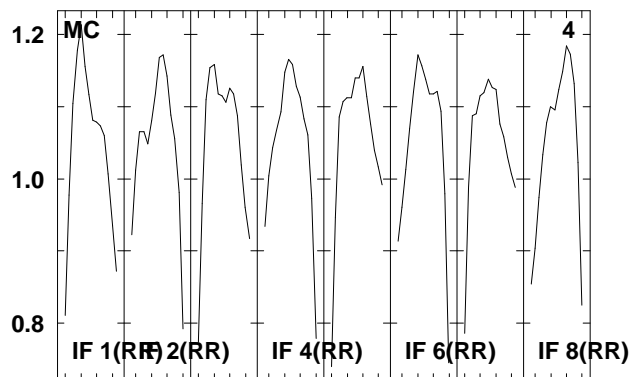
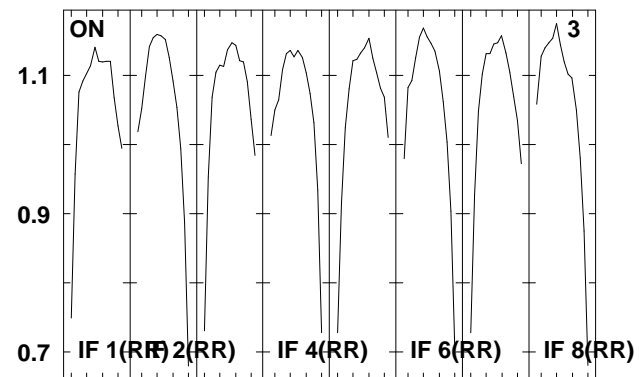
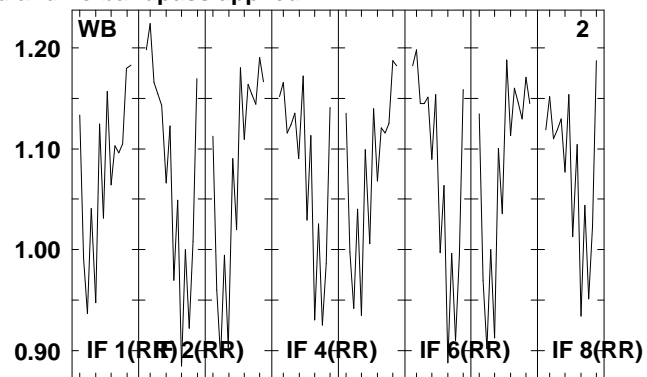
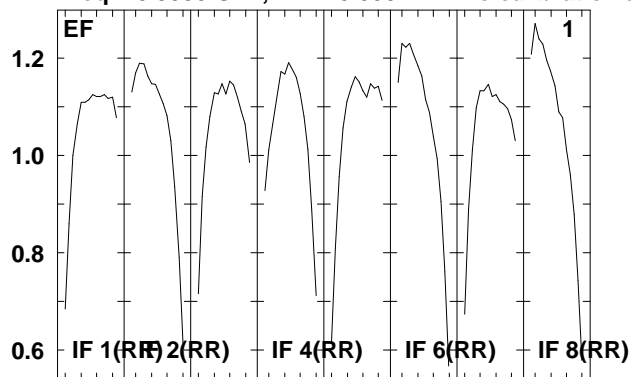

Lower frame: Real Jy  
Total-power spectrum Antenna: \*  
Timerange: 01/01:45:26 to 01/01:46:54

Plot file version 183 created 05-OCT-2009 09:28:45

NGC6240 EH023B 2.UVDATA.1

Freq = 8.3535 GHz, Bw = 8.000 MH No calibration applied and no bandpass applied

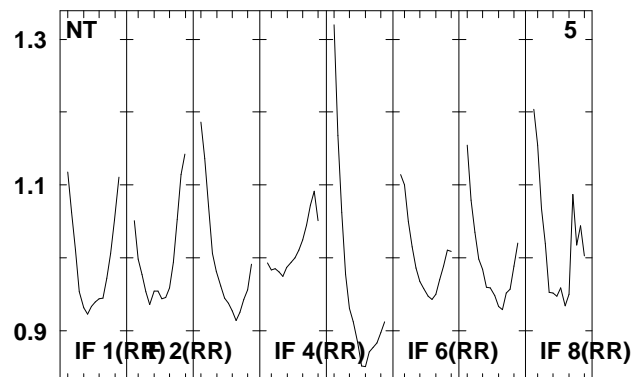
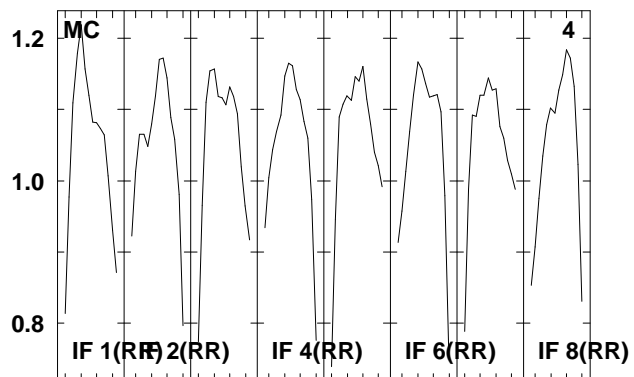
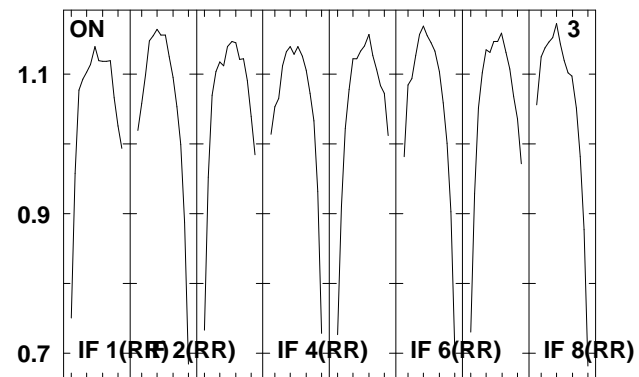
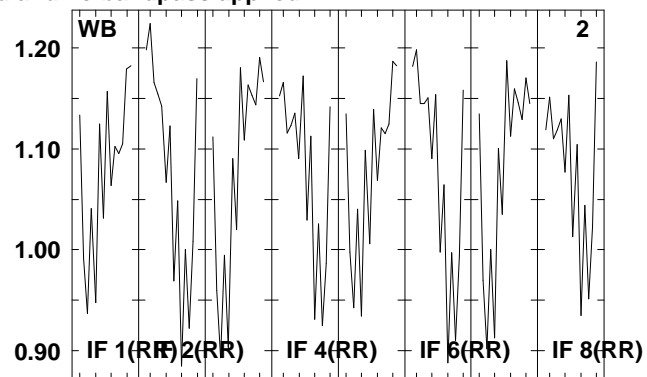
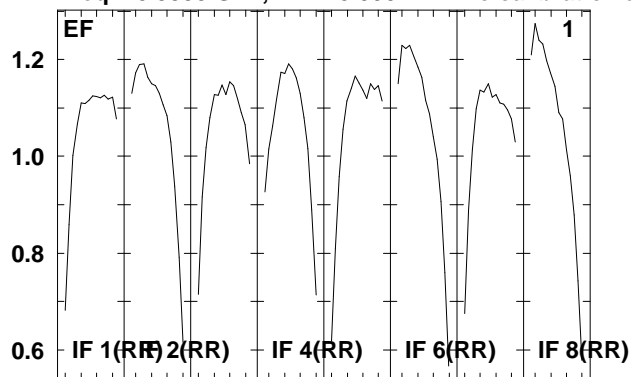

Lower frame: Real Jy  
Total-power spectrum Antenna: \*  
Timerange: 01/01:46:56 to 01/01:50:24

Plot file version 184 created 05-OCT-2009 09:28:45

J1651+01 EH023B 2.UVDATA.1

Freq = 8.3535 GHz, Bw = 8.000 MH No calibration applied and no bandpass applied

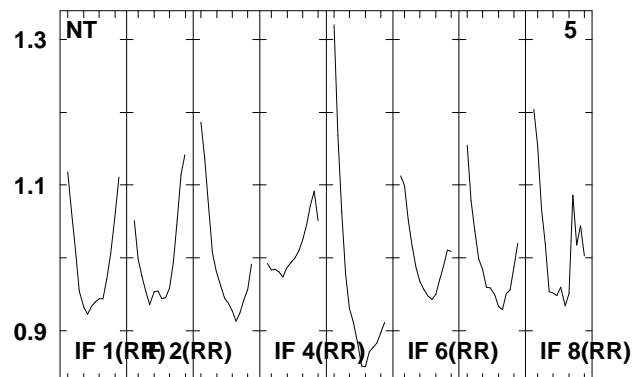
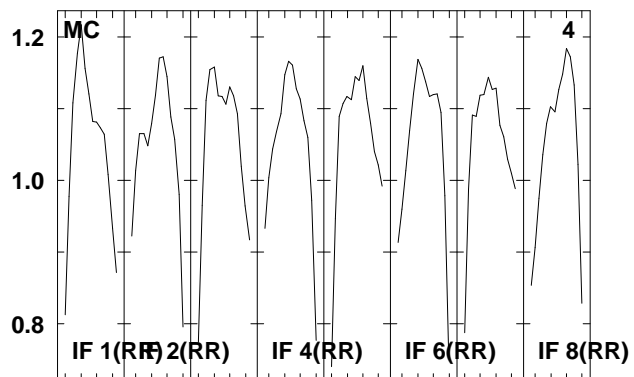
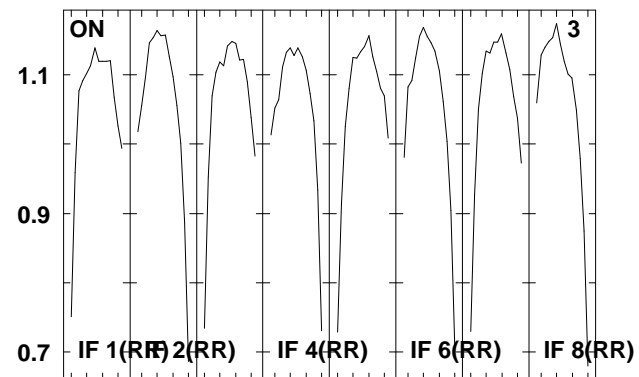
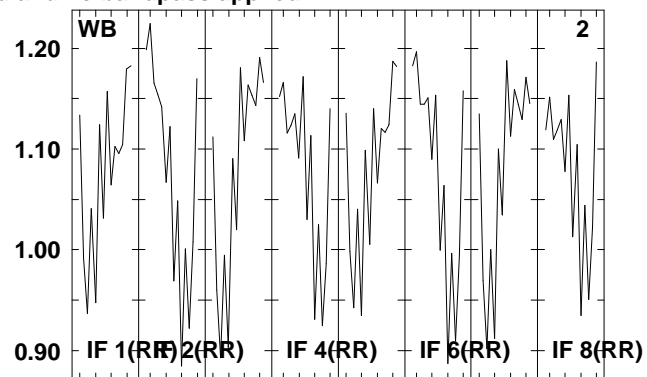
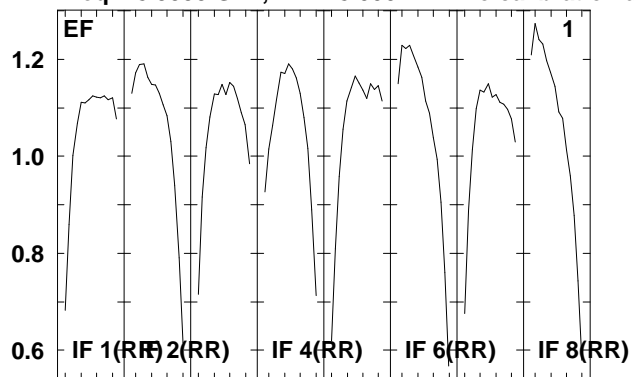

Lower frame: Real Jy  
Total-power spectrum Antenna: \*  
Timerange: 01/01:50:26 to 01/01:51:54



Plot file version 185 created 05-OCT-2009 09:28:45

NGC6240 EH023B 2.UVDATA.1

Freq = 8.3535 GHz, Bw = 8.000 MH No calibration applied and no bandpass applied

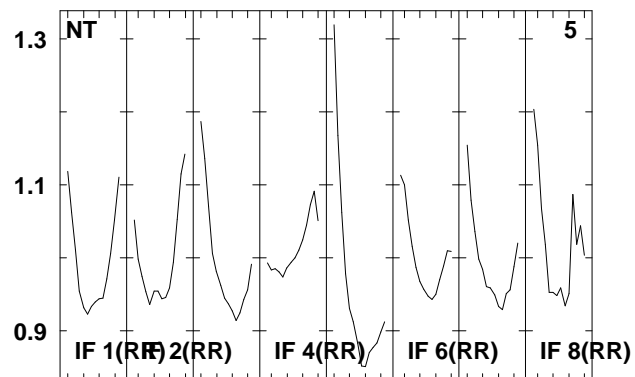
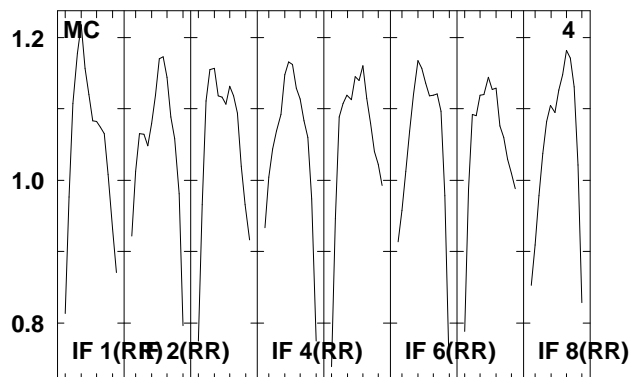
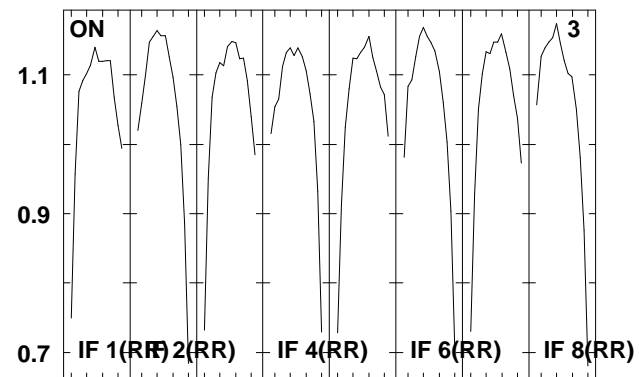
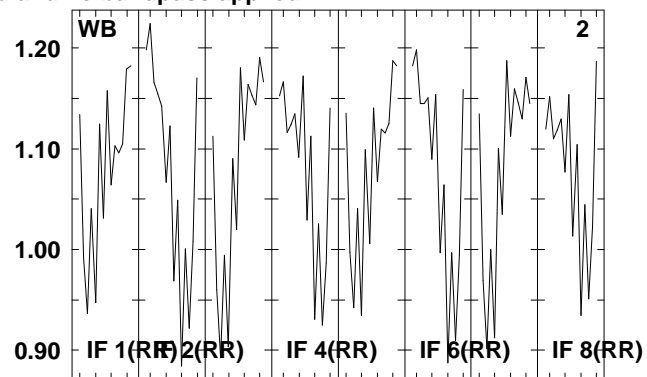
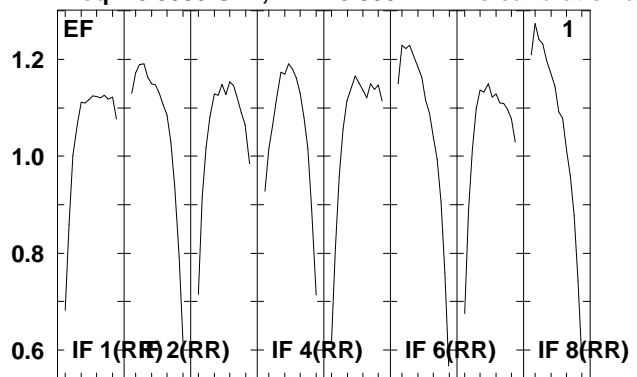

Lower frame: Real Jy  
Total-power spectrum Antenna: \*  
Timerange: 01/01:51:56 to 01/01:55:24

Plot file version 186 created 05-OCT-2009 09:28:45

J1651+01 EH023B 2.UVDATA.1

Freq = 8.3535 GHz, Bw = 8.000 MH No calibration applied and no bandpass applied

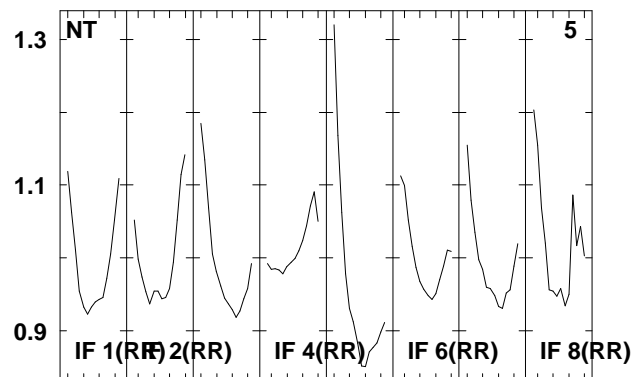
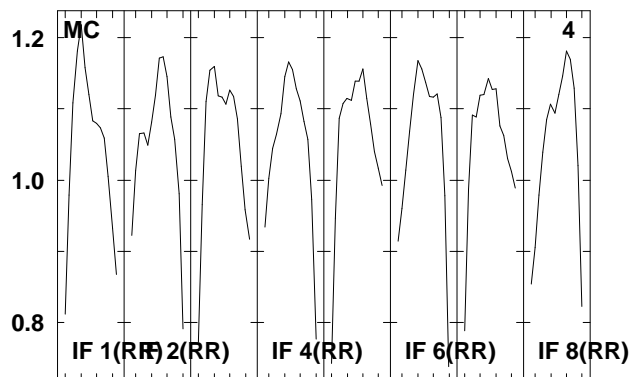
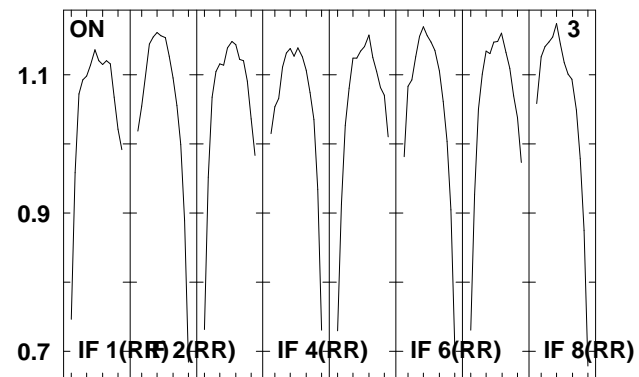
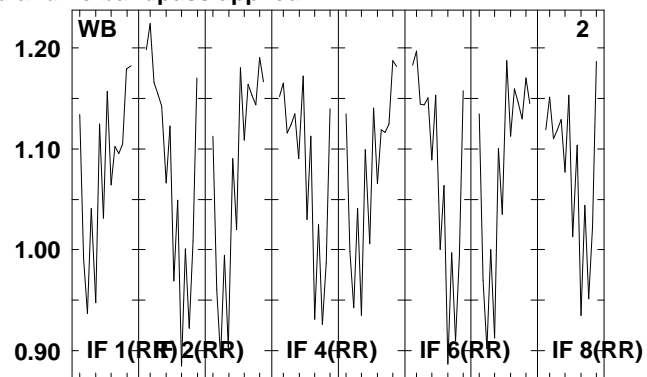
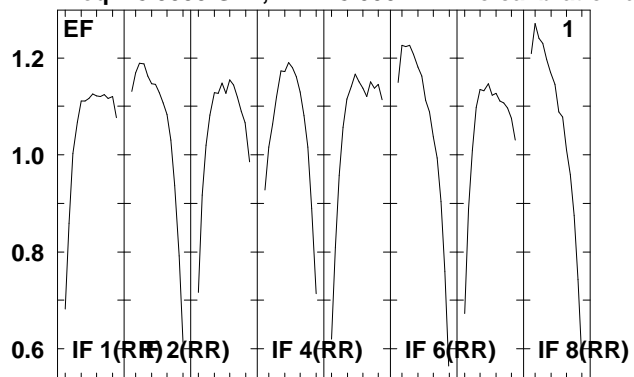

Lower frame: Real Jy  
Total-power spectrum Antenna: \*  
Timerange: 01/01:55:56 to 01/01:57:24

Plot file version 187 created 05-OCT-2009 09:28:45

NGC6240 EH023B 2.UVDATA.1

Freq = 8.3535 GHz, Bw = 8.000 MH No calibration applied and no bandpass applied

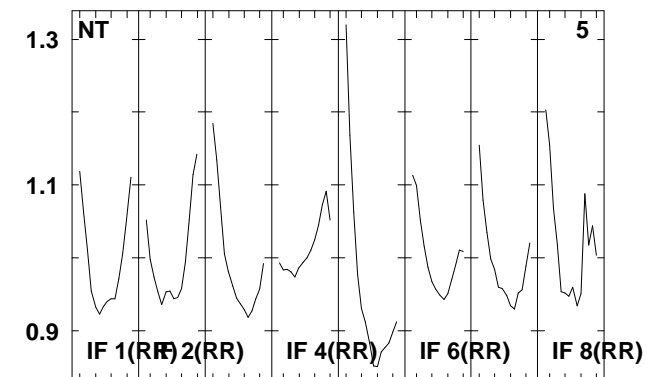
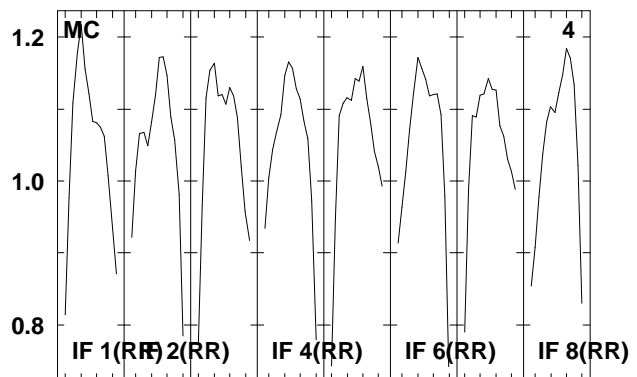
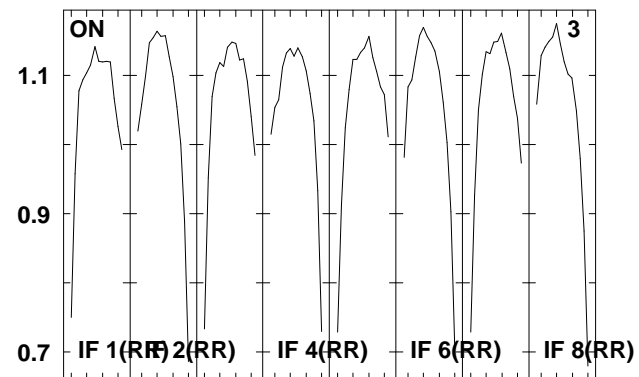
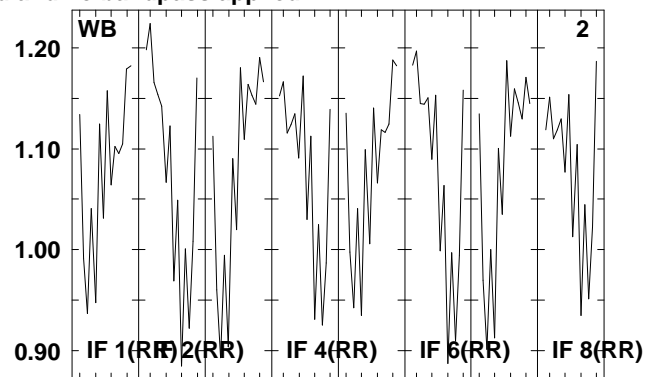
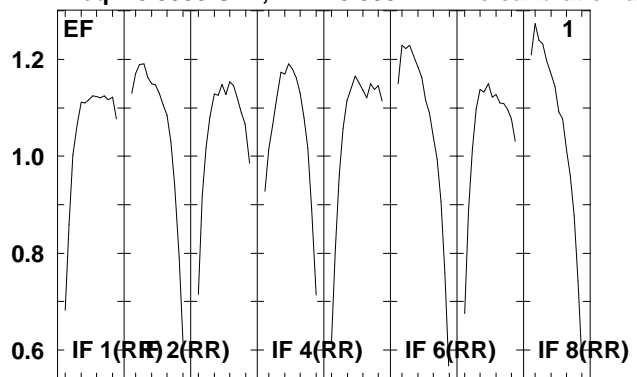

Lower frame: Real Jy  
Total-power spectrum Antenna: \*  
Timerange: 01/01:57:26 to 01/02:00:54

Plot file version 188 created 05-OCT-2009 09:28:45

J1651+01 EH023B 2.UVDATA.1

Freq = 8.3535 GHz, Bw = 8.000 MH No calibration applied and no bandpass applied

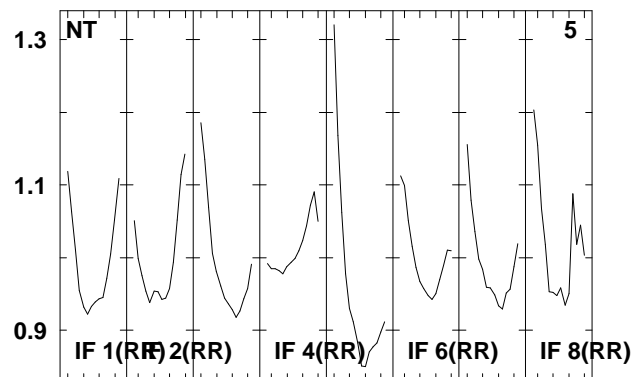
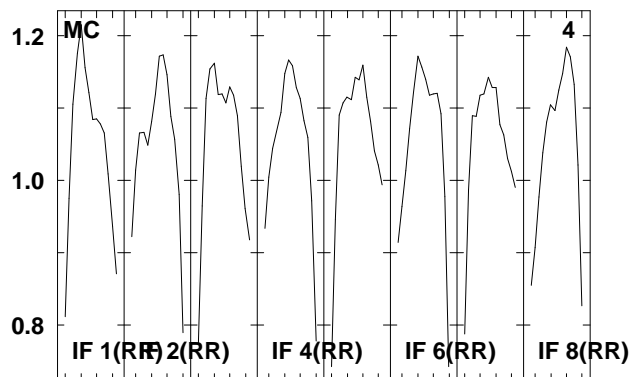
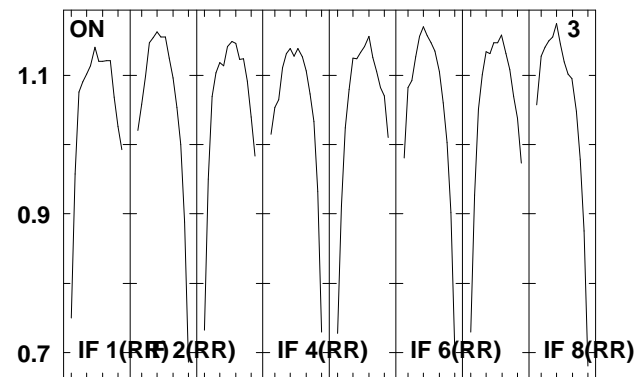
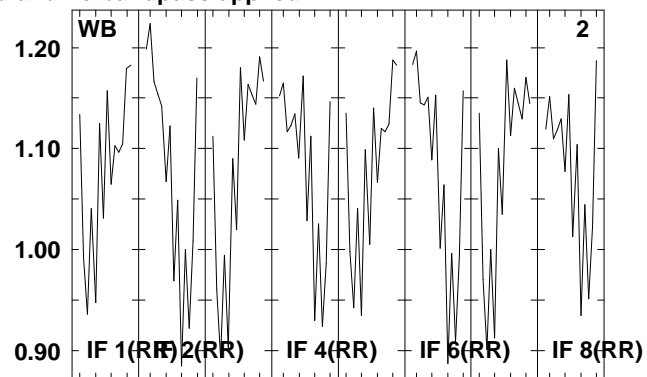
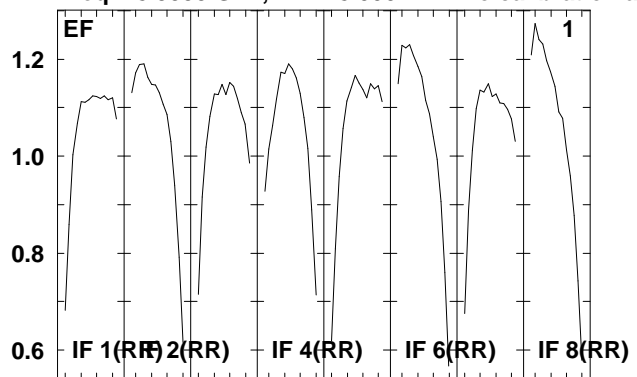

Lower frame: Real Jy  
Total-power spectrum Antenna: \*  
Timerange: 01/02:00:56 to 01/02:02:24

Plot file version 189 created 05-OCT-2009 09:28:46

NGC6240 EH023B 2.UVDATA.1

Freq = 8.3535 GHz, Bw = 8.000 MH No calibration applied and no bandpass applied

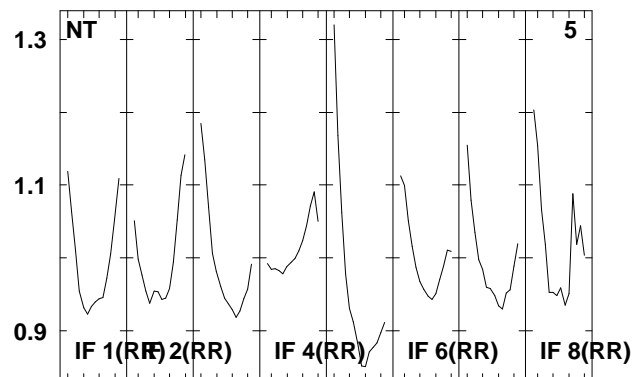
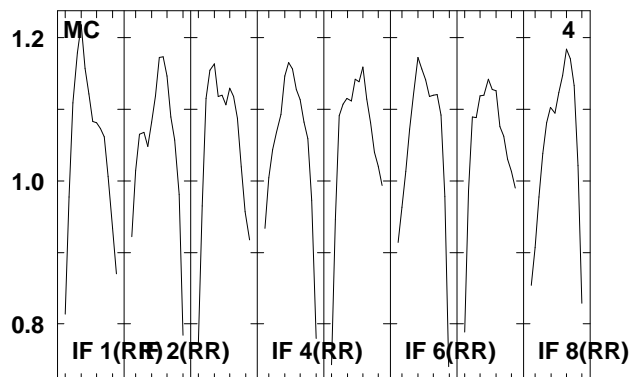
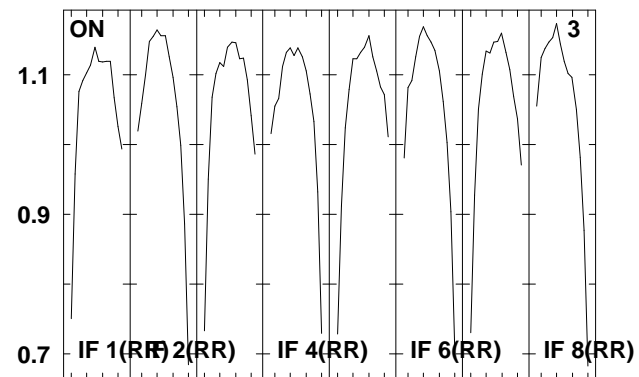
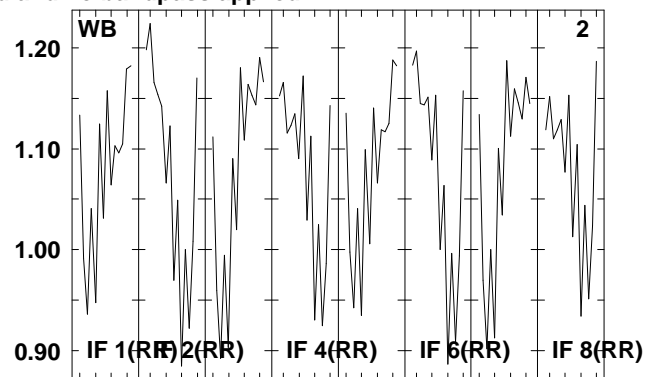
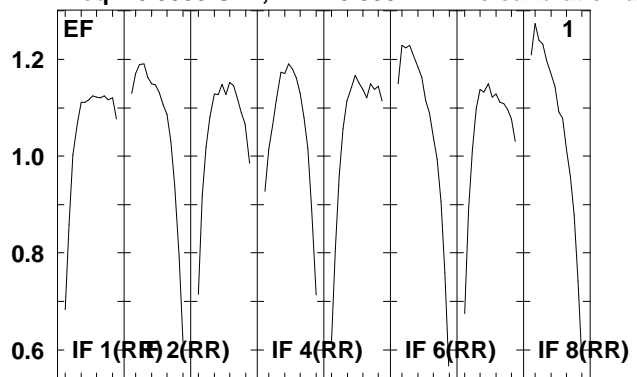

Lower frame: Real Jy  
Total-power spectrum Antenna: \*  
Timerange: 01/02:02:26 to 01/02:05:54

Plot file version 190 created 05-OCT-2009 09:28:46

J1651+01 EH023B 2.UVDATA.1

Freq = 8.3535 GHz, Bw = 8.000 MH No calibration applied and no bandpass applied

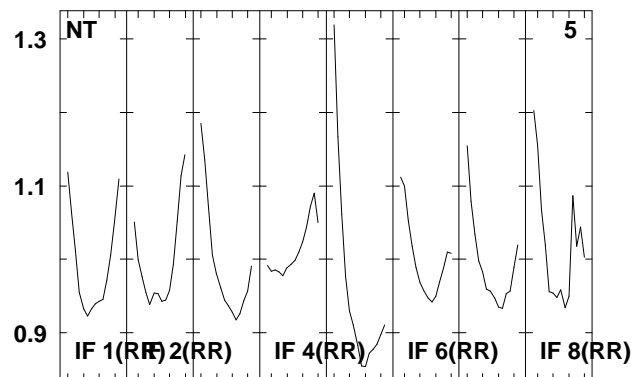
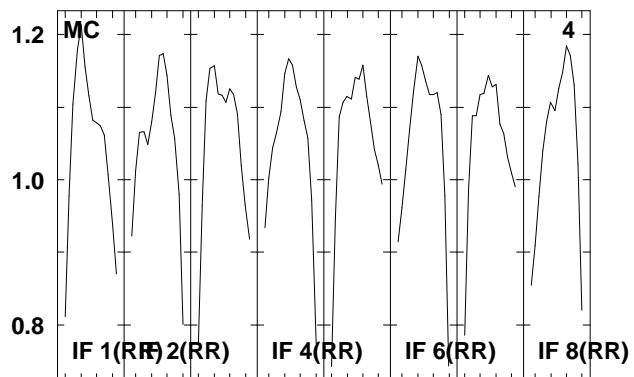
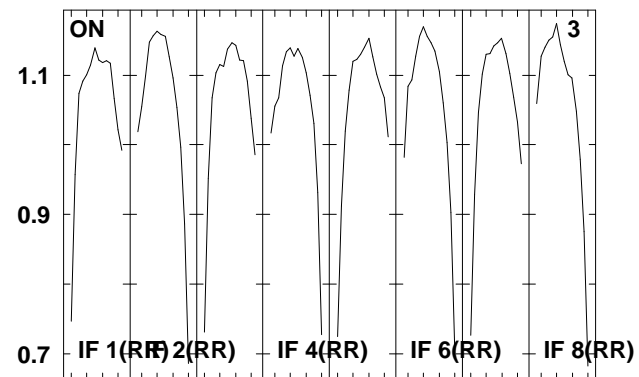
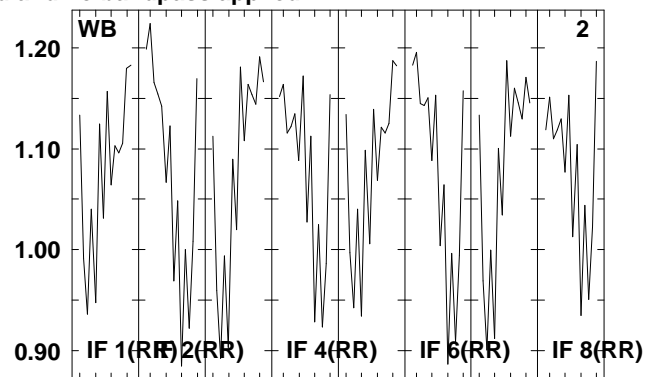
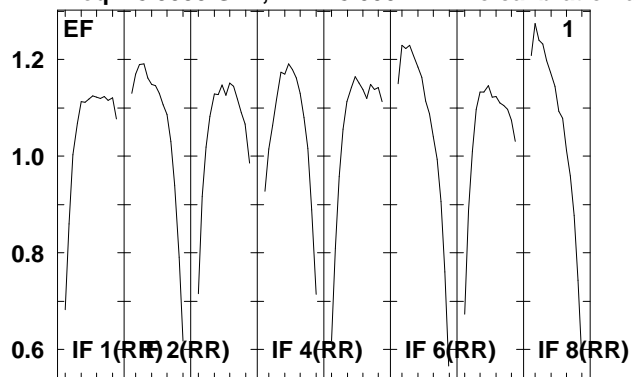

Lower frame: Real Jy  
Total-power spectrum Antenna: \*  
Timerange: 01/02:06:26 to 01/02:07:54

Plot file version 191 created 05-OCT-2009 09:28:46

NGC6240 EH023B 2.UVDATA.1

Freq = 8.3535 GHz, Bw = 8.000 MH No calibration applied and no bandpass applied

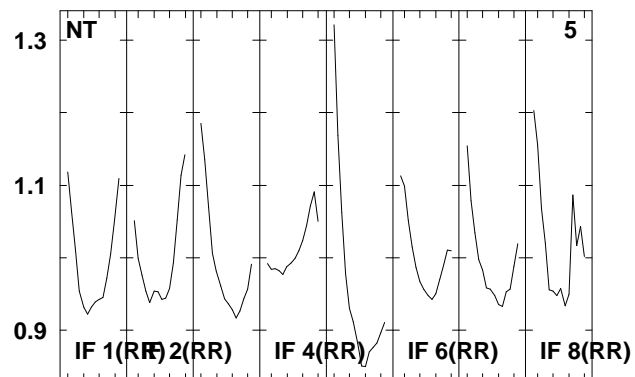
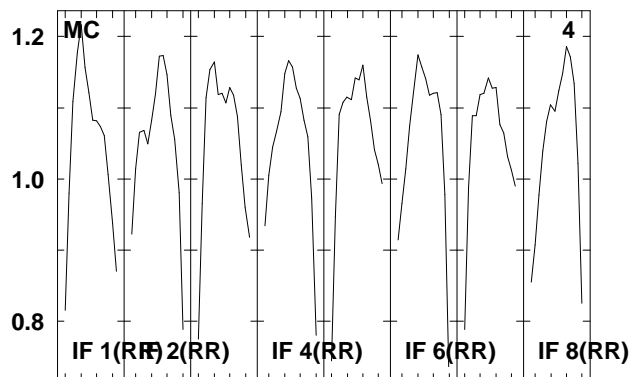
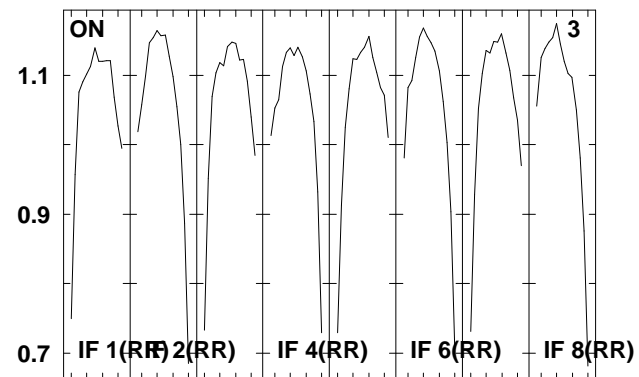
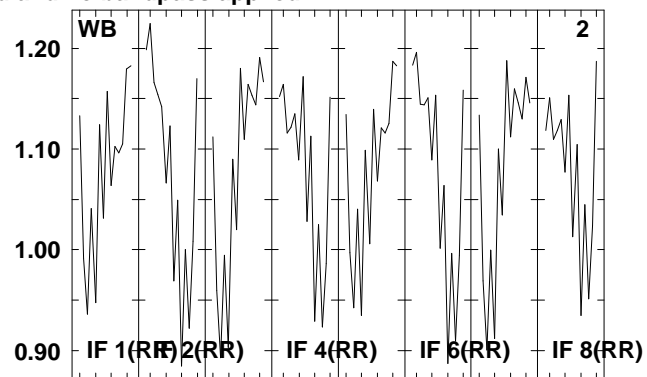
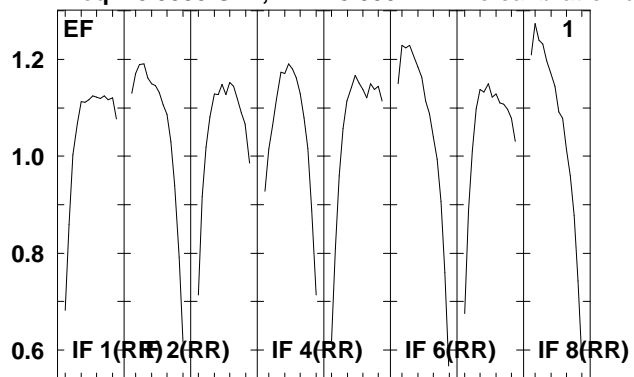

Lower frame: Real Jy  
Total-power spectrum Antenna: \*  
Timerange: 01/02:07:56 to 01/02:11:24

Plot file version 192 created 05-OCT-2009 09:28:46

J1651+01 EH023B 2.UVDATA.1

Freq = 8.3535 GHz, Bw = 8.000 MH No calibration applied and no bandpass applied

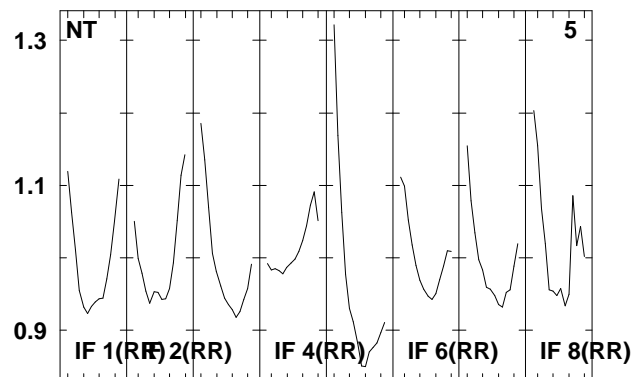
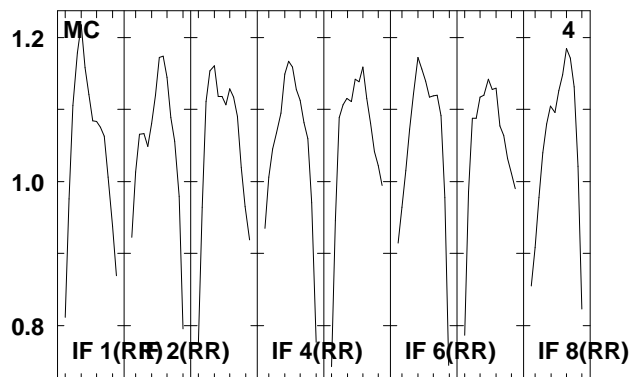
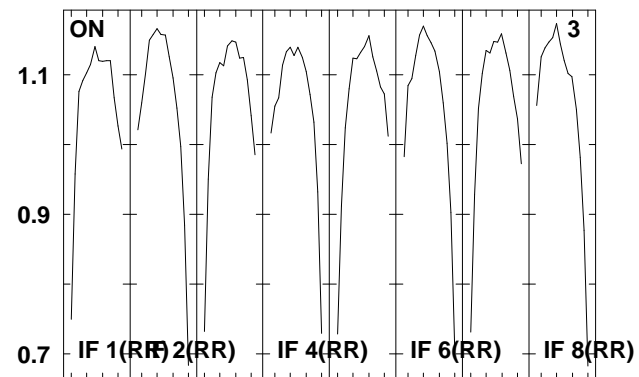
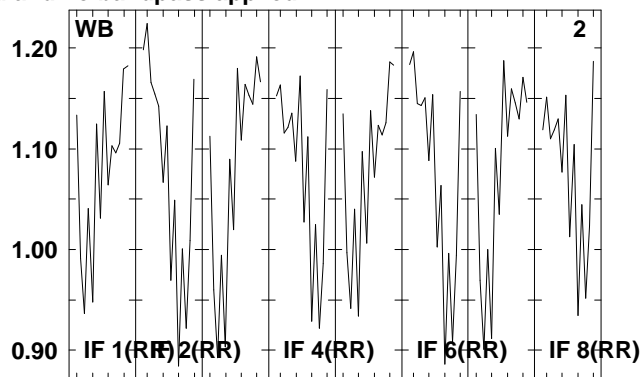
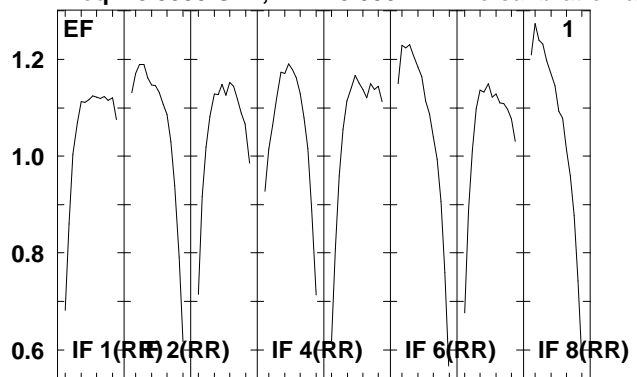

Lower frame: Real Jy  
Total-power spectrum Antenna: \*  
Timerange: 01/02:11:26 to 01/02:12:54



Plot file version 193 created 05-OCT-2009 09:28:46

NGC6240 EH023B 2.UVDATA.1

Freq = 8.3535 GHz, Bw = 8.000 MH No calibration applied and no bandpass applied

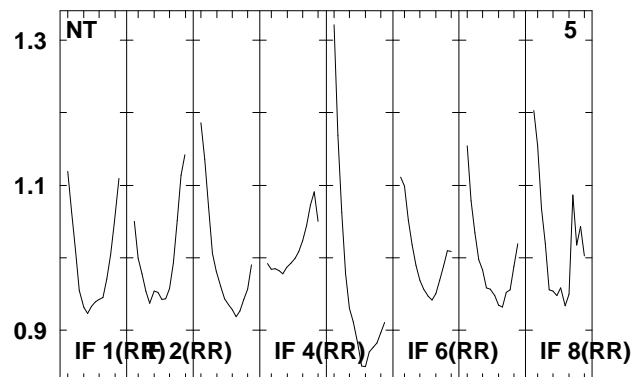
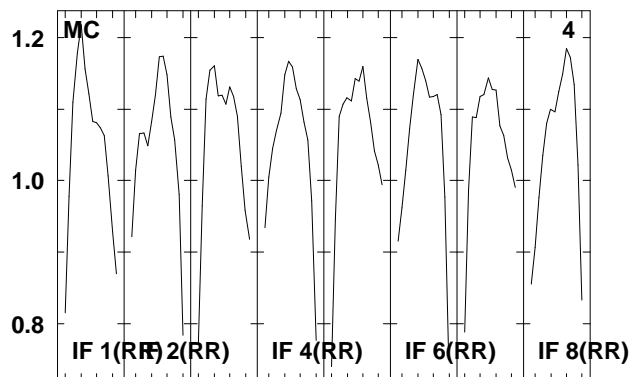
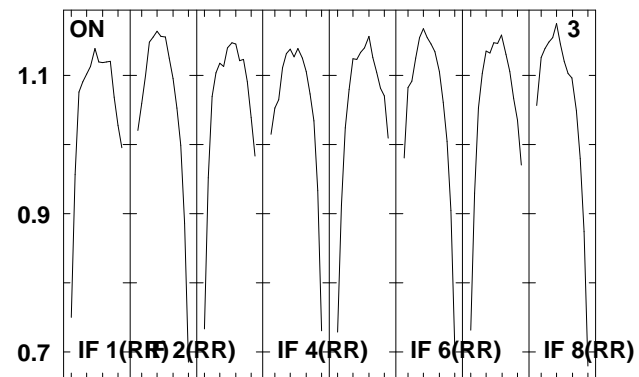
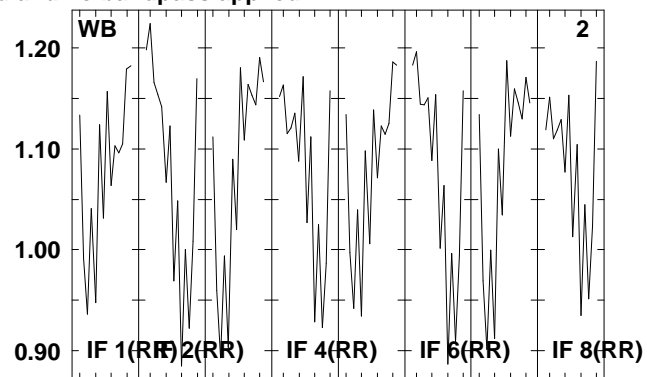
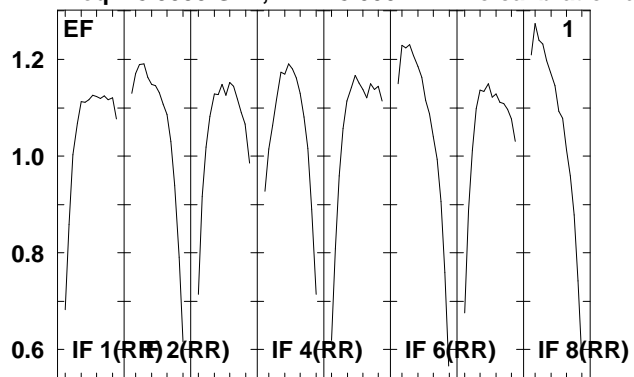

Lower frame: Real Jy  
Total-power spectrum Antenna: \*  
Timerange: 01/02:12:56 to 01/02:16:24

Plot file version 194 created 05-OCT-2009 09:28:46

J1651+01 EH023B 2.UVDATA.1

Freq = 8.3535 GHz, Bw = 8.000 MH No calibration applied and no bandpass applied

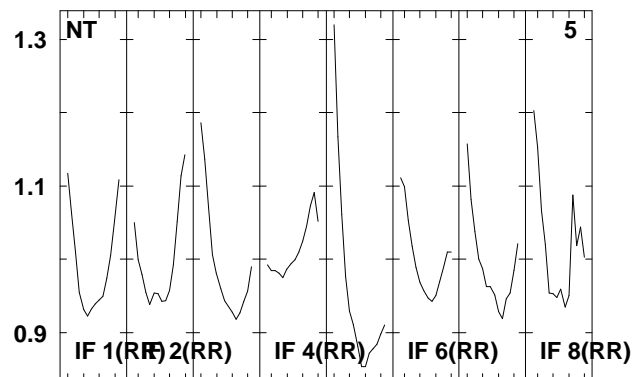
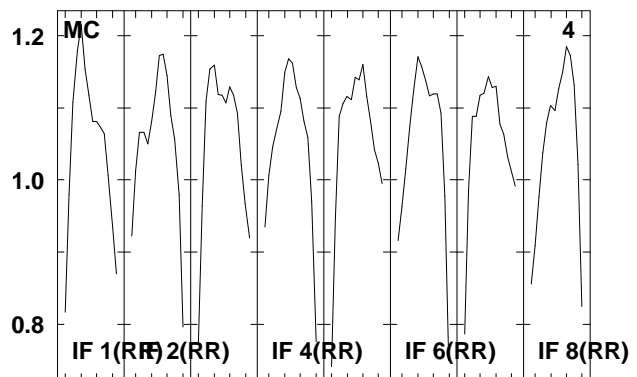
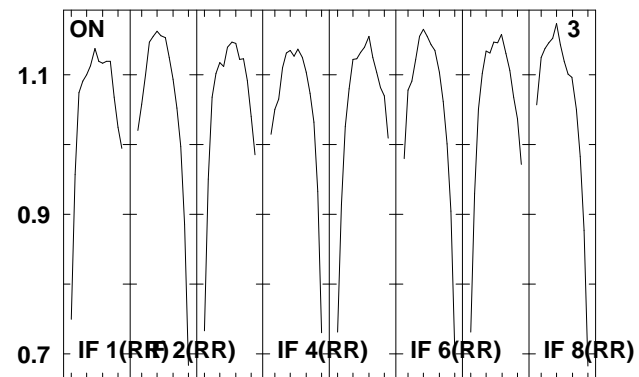
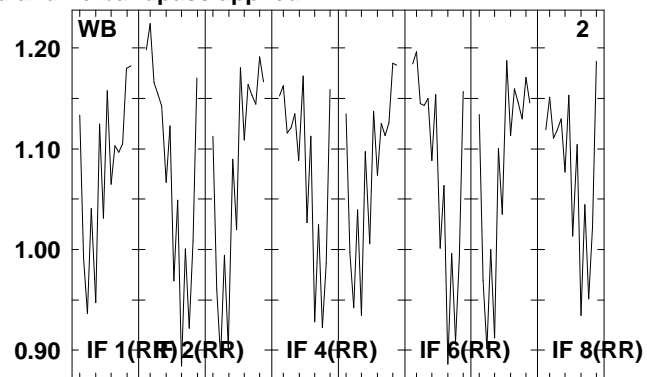
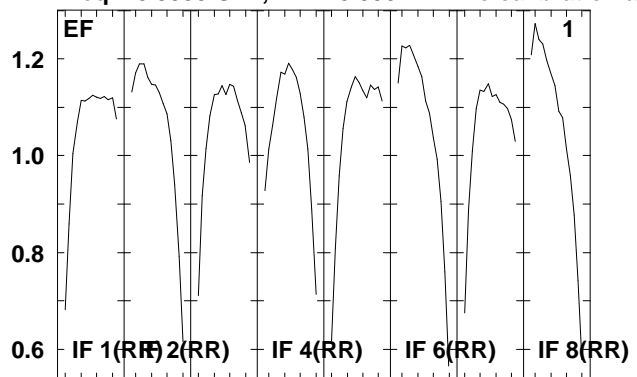

Lower frame: Real Jy  
Total-power spectrum Antenna: \*  
Timerange: 01/02:16:56 to 01/02:18:24

Plot file version 195 created 05-OCT-2009 09:28:46

NGC6240 EH023B 2.UVDATA.1

Freq = 8.3535 GHz, Bw = 8.000 MH No calibration applied and no bandpass applied

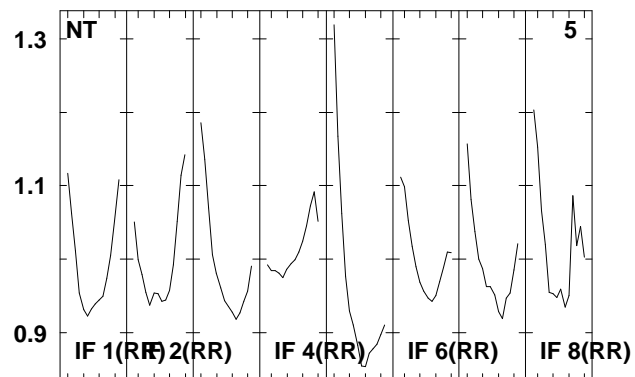
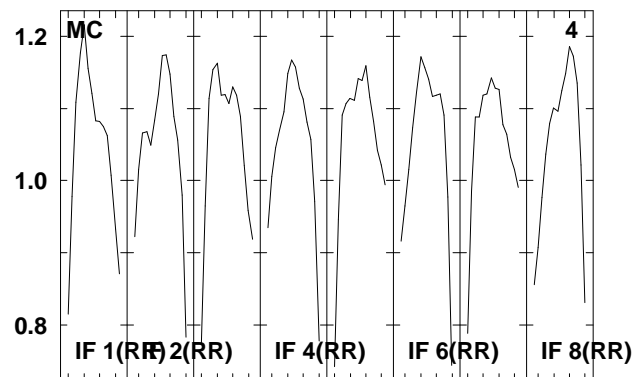
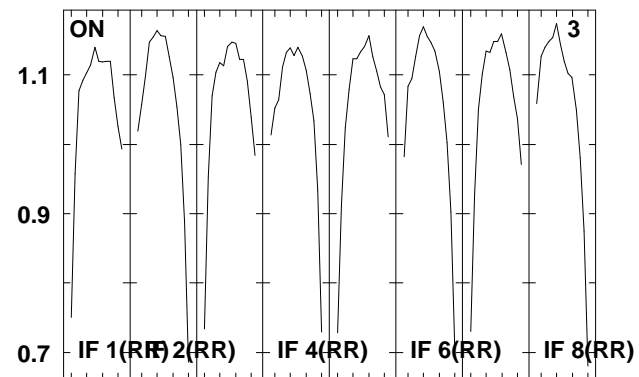
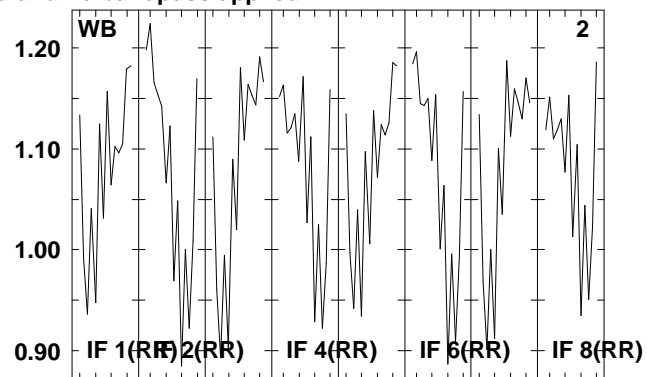
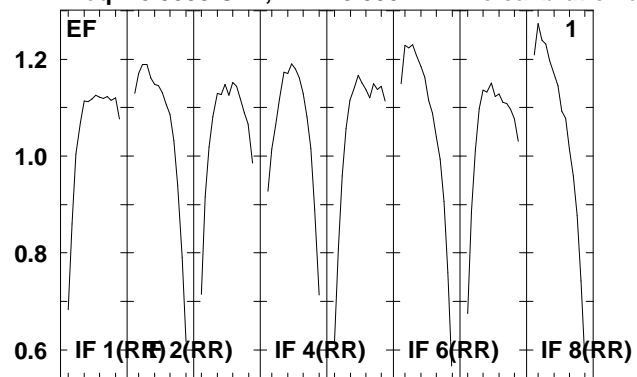

Lower frame: Real Jy  
Total-power spectrum Antenna: \*  
Timerange: 01/02:18:26 to 01/02:21:54

Plot file version 196 created 05-OCT-2009 09:28:46

J1651+01 EH023B 2.UVDATA.1

Freq = 8.3535 GHz, Bw = 8.000 MH No calibration applied and no bandpass applied

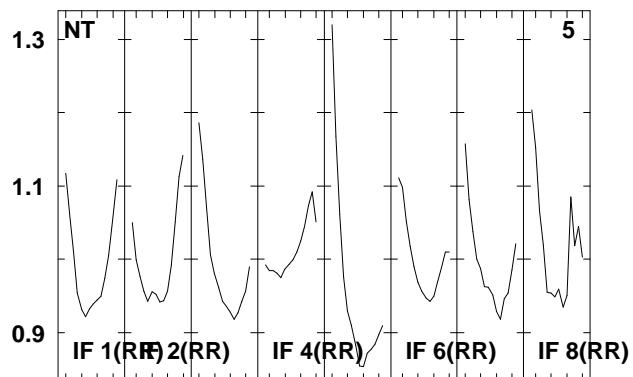
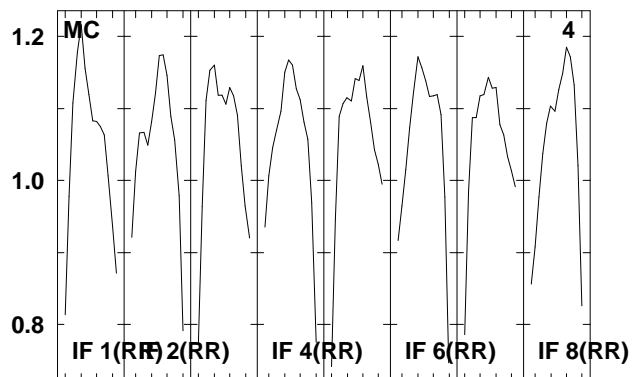
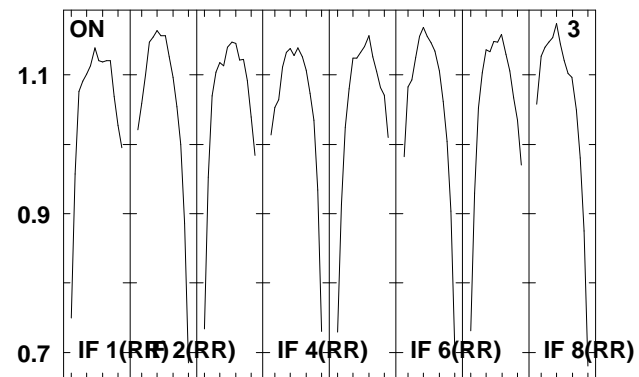
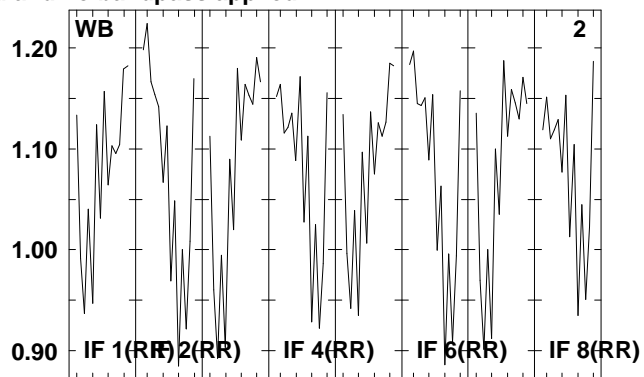
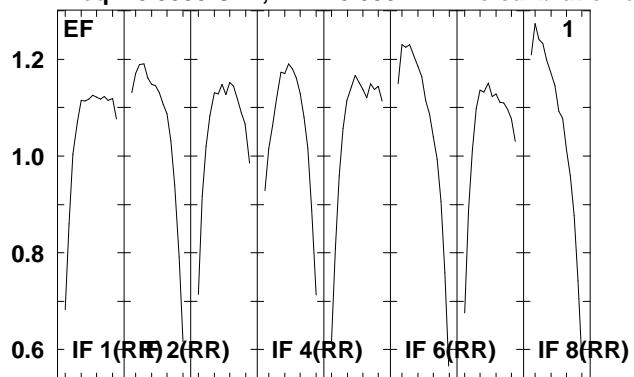

Lower frame: Real Jy  
Total-power spectrum Antenna: \*  
Timerange: 01/02:21:56 to 01/02:23:24

Plot file version 197 created 05-OCT-2009 09:28:47

NGC6240 EH023B 2.UVDATA.1

Freq = 8.3535 GHz, Bw = 8.000 MH No calibration applied and no bandpass applied

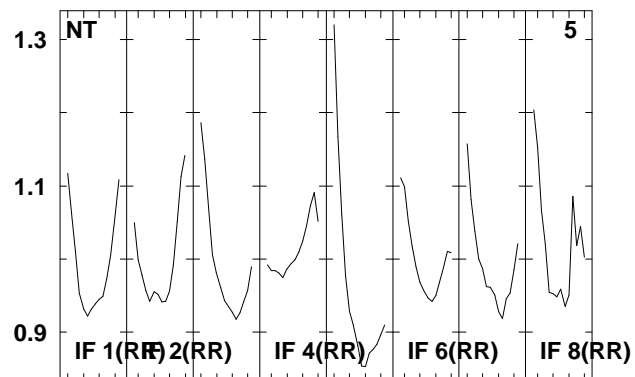
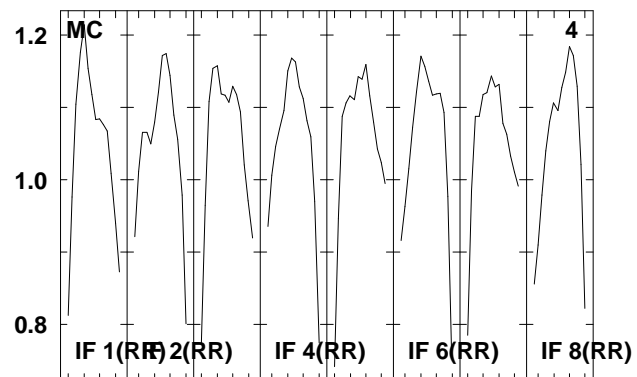
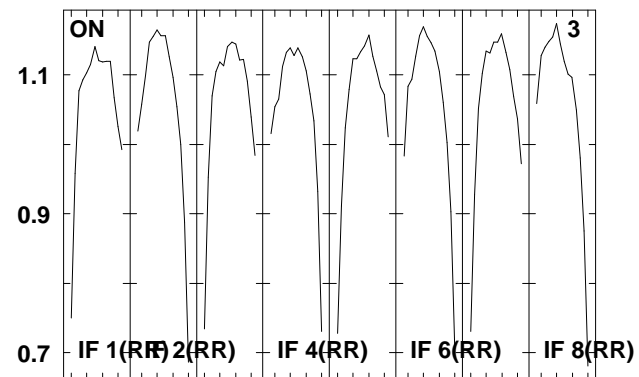
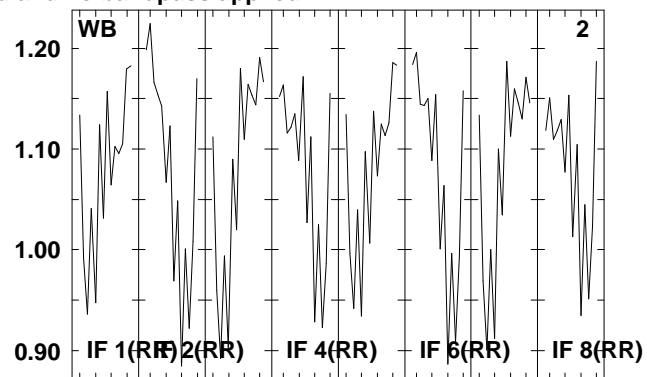
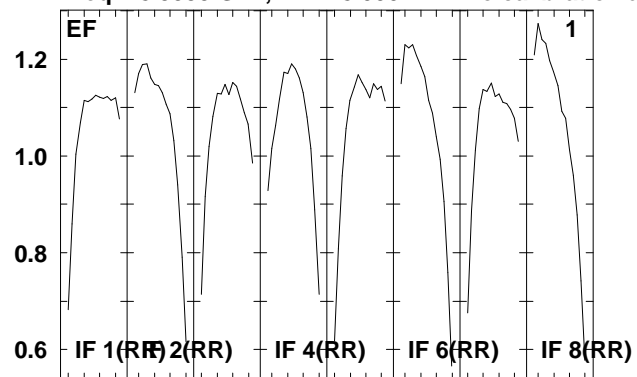

Lower frame: Real Jy  
Total-power spectrum Antenna: \*  
Timerange: 01/02:23:26 to 01/02:26:54

Plot file version 198 created 05-OCT-2009 09:28:47

J1651+01 EH023B 2.UVDATA.1

Freq = 8.3535 GHz, Bw = 8.000 MH No calibration applied and no bandpass applied

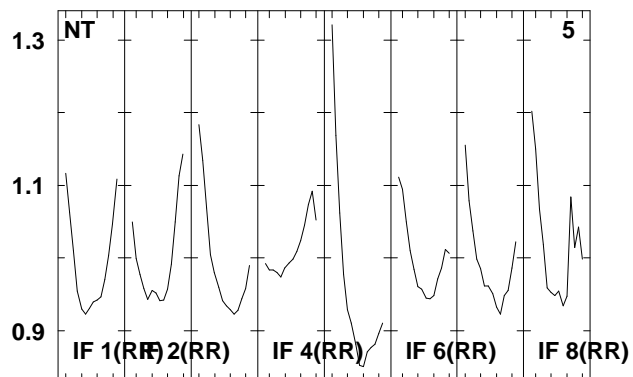
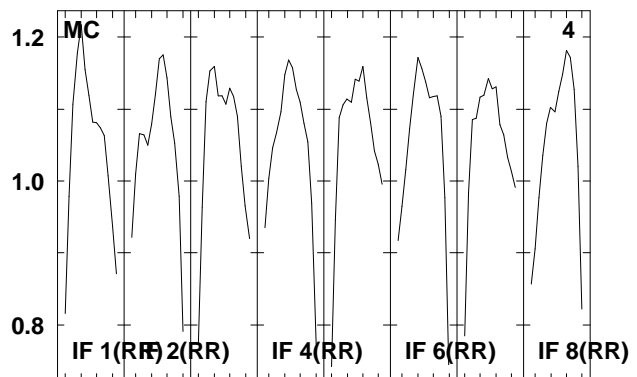
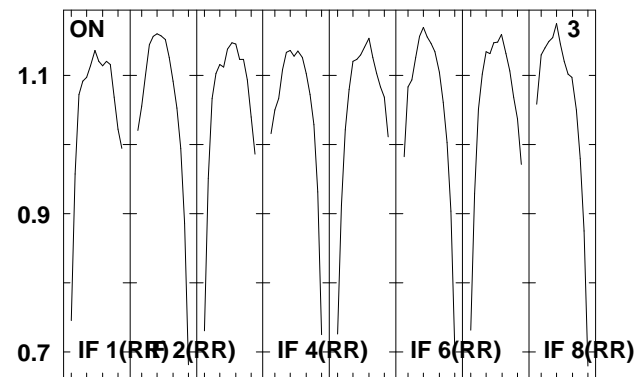
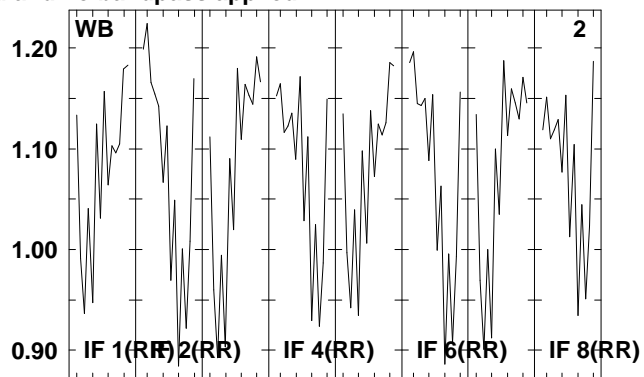
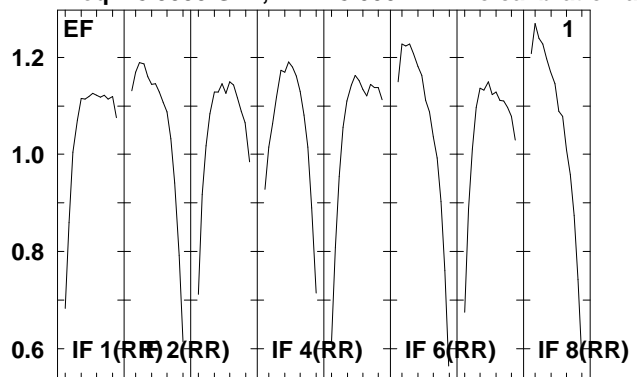

Lower frame: Real Jy  
Total-power spectrum Antenna: \*  
Timerange: 01/02:27:26 to 01/02:28:54

Plot file version 199 created 05-OCT-2009 09:28:47

NGC6240 EH023B 2.UVDATA.1

Freq = 8.3535 GHz, Bw = 8.000 MH No calibration applied and no bandpass applied

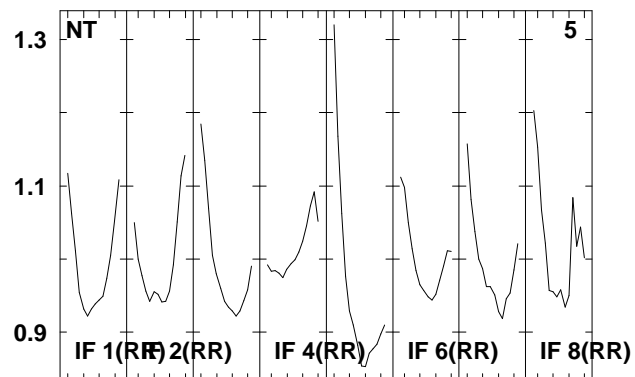
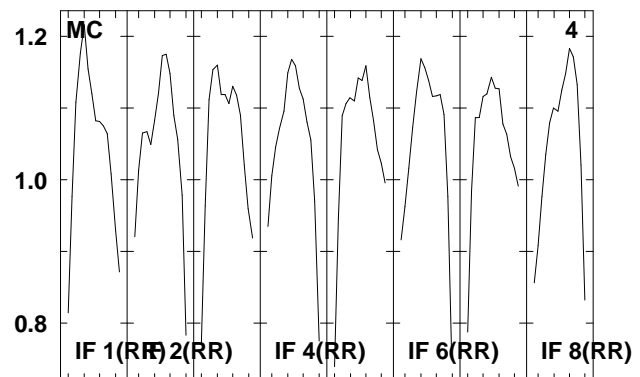
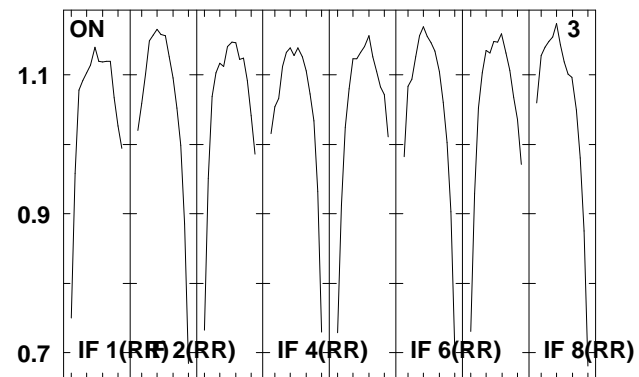
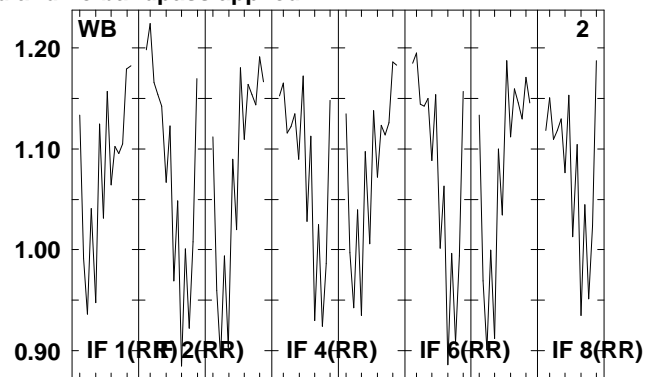
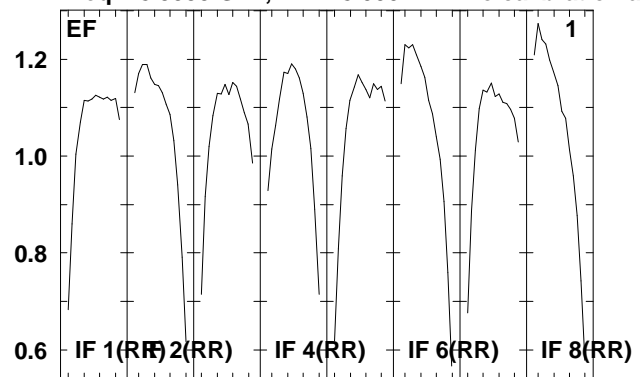

Lower frame: Real Jy  
Total-power spectrum Antenna: \*  
Timerange: 01/02:28:56 to 01/02:32:24

Plot file version 200 created 05-OCT-2009 09:28:47

J1651+01 EH023B 2.UVDATA.1

Freq = 8.3535 GHz, Bw = 8.000 MH No calibration applied and no bandpass applied

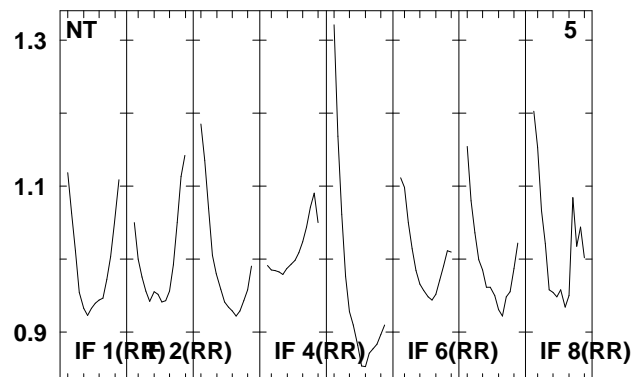
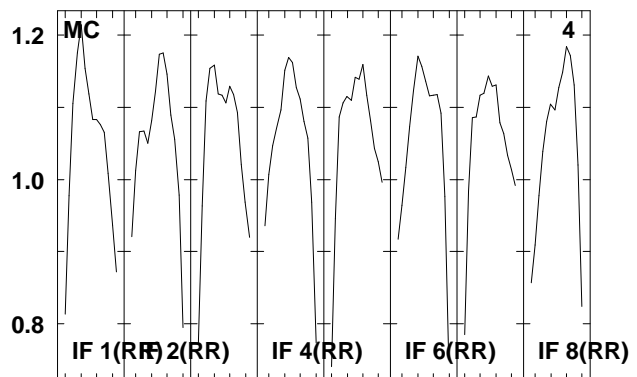
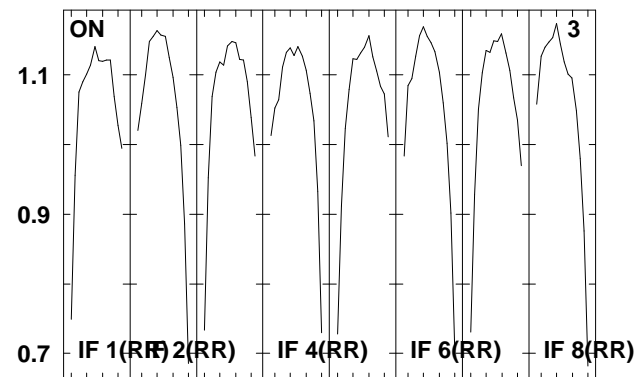
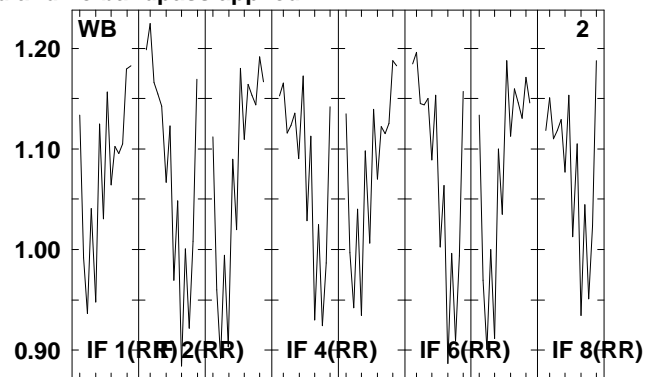
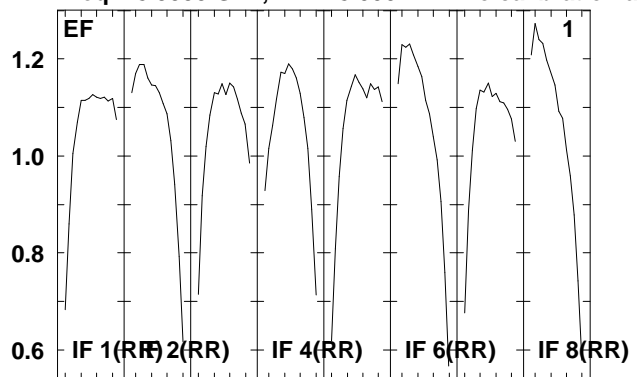

Lower frame: Real Jy  
Total-power spectrum Antenna: \*  
Timerange: 01/02:32:26 to 01/02:33:54



Plot file version 201 created 05-OCT-2009 09:28:47

NGC6240 EH023B 2.UVDATA.1

Freq = 8.3535 GHz, Bw = 8.000 MH No calibration applied and no bandpass applied

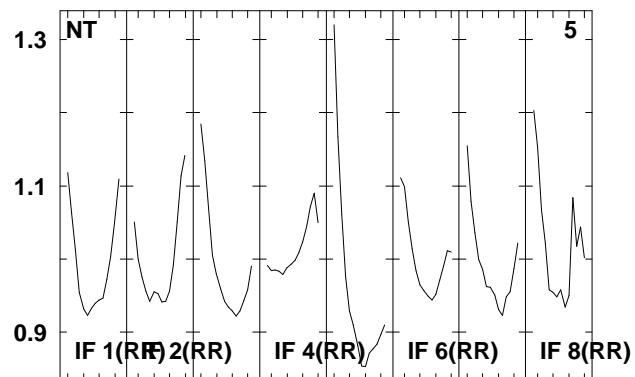
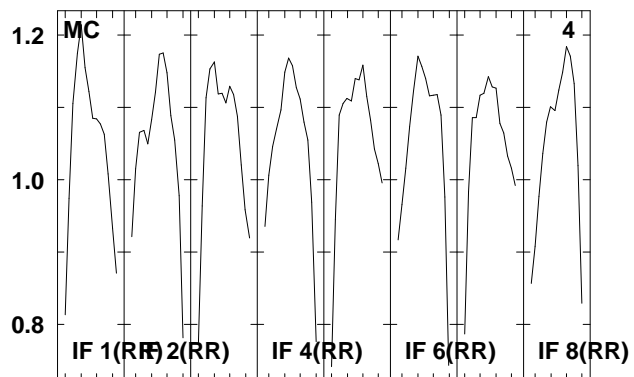
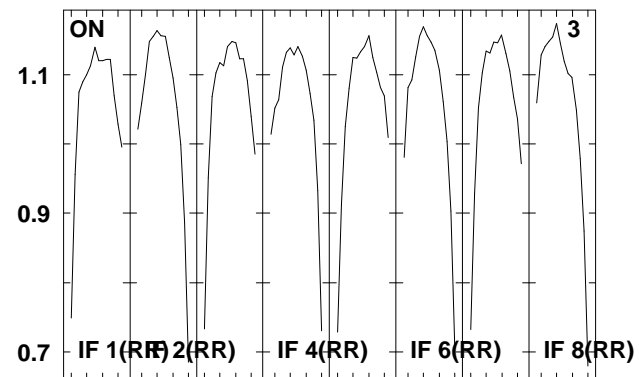
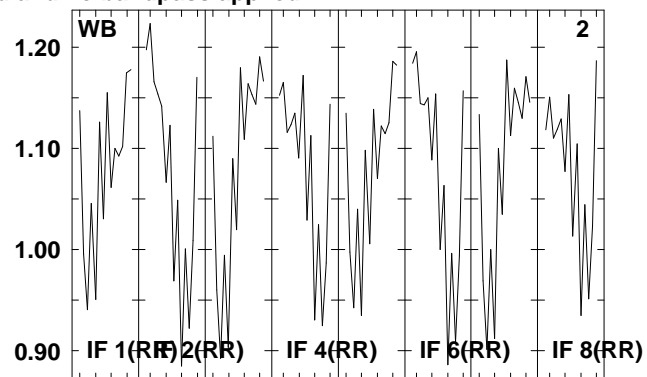
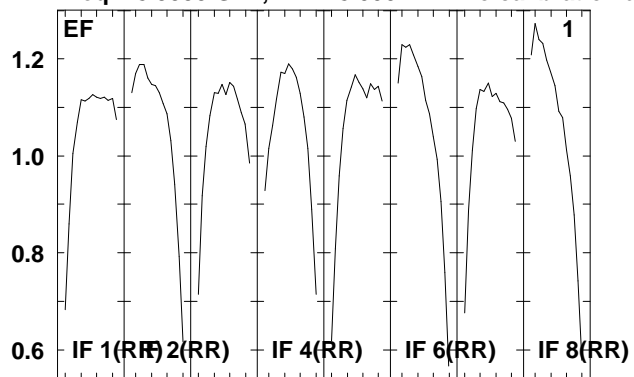

Lower frame: Real Jy  
Total-power spectrum Antenna: \*  
Timerange: 01/02:33:56 to 01/02:37:22

Plot file version 202 created 05-OCT-2009 09:28:47

J1651+01 EH023B 2.UVDATA.1

Freq = 8.3535 GHz, Bw = 8.000 MH No calibration applied and no bandpass applied

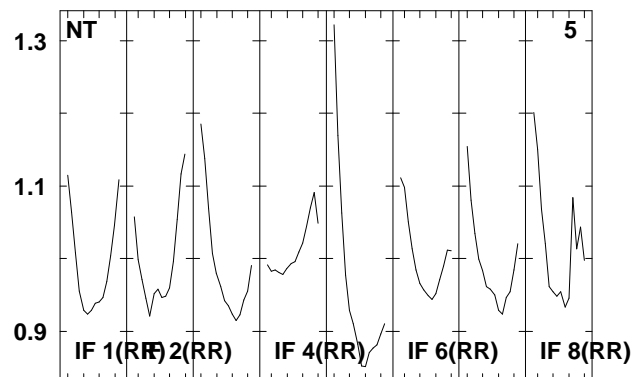
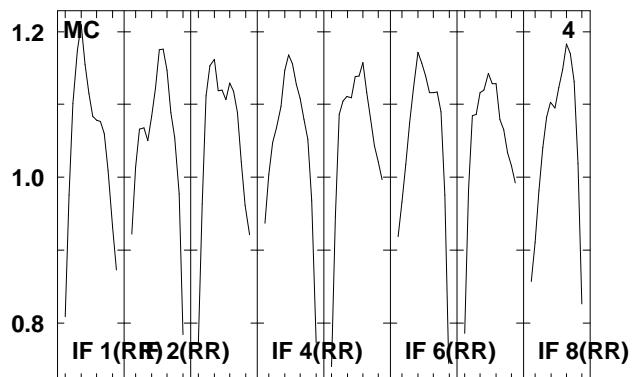
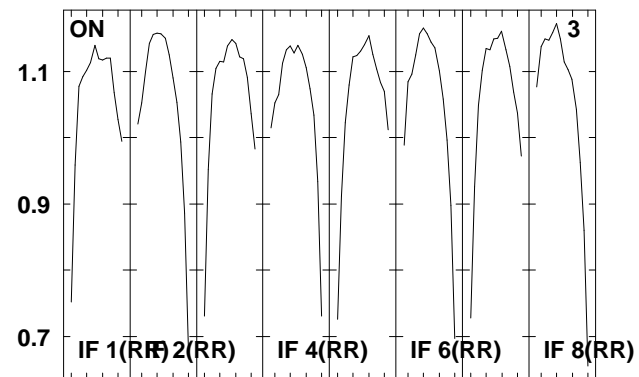
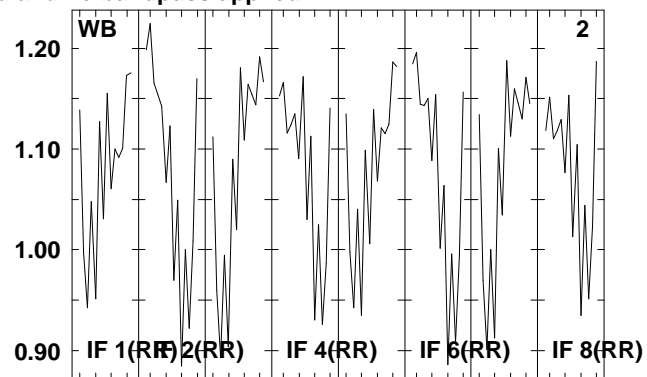
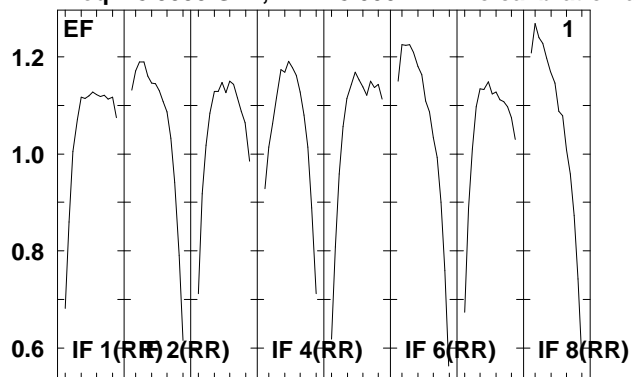

Lower frame: Real Jy  
Total-power spectrum Antenna: \*  
Timerange: 01/02:37:56 to 01/02:39:22

Plot file version 203 created 05-OCT-2009 09:28:47

NGC6240 EH023B 2.UVDATA.1

Freq = 8.3535 GHz, Bw = 8.000 MH No calibration applied and no bandpass applied

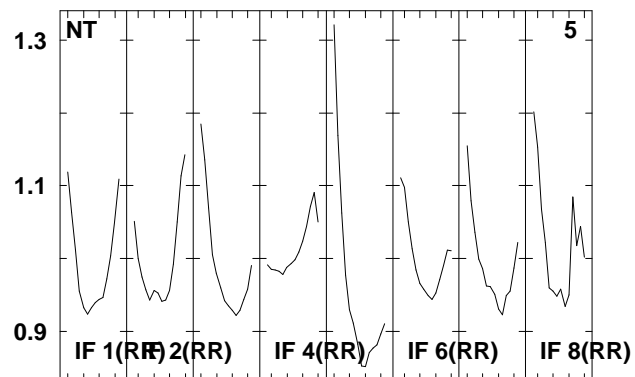
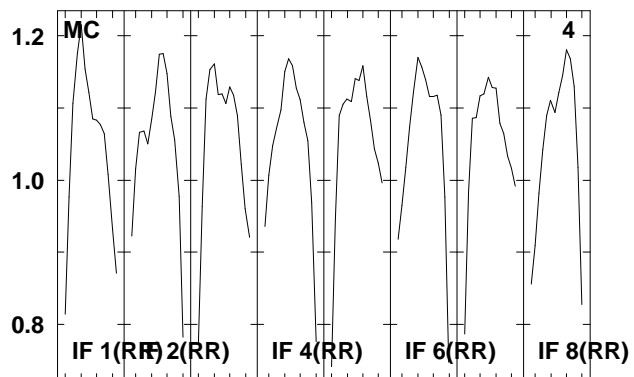
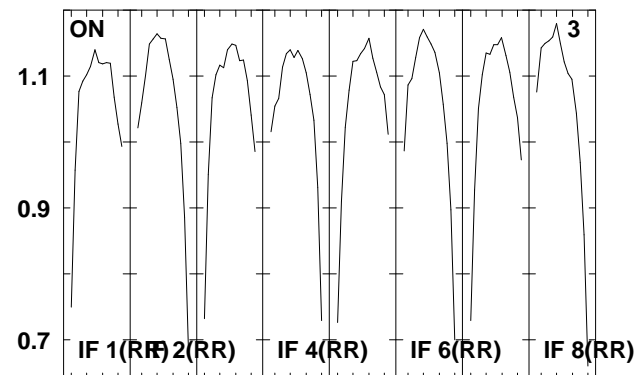
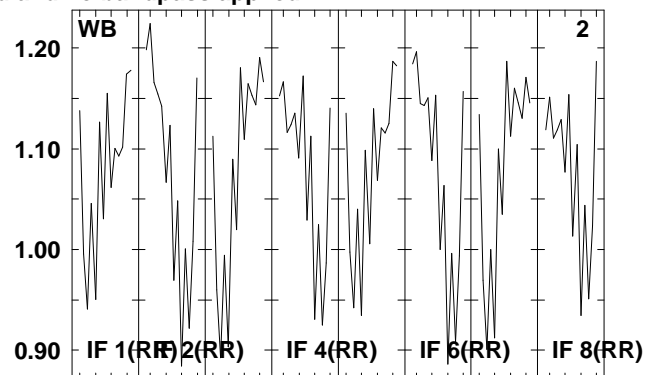
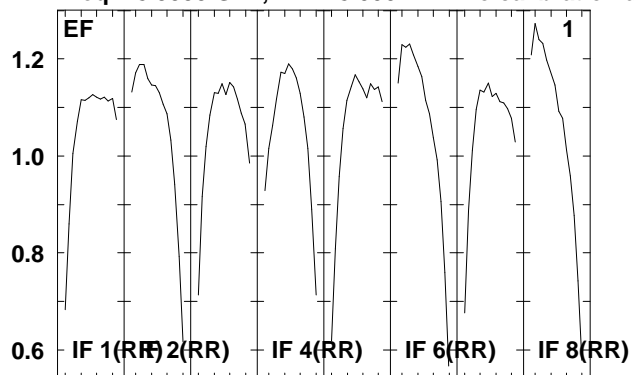

Lower frame: Real Jy  
Total-power spectrum Antenna: \*  
Timerange: 01/02:39:28 to 01/02:42:54

Plot file version 204 created 05-OCT-2009 09:28:48

J1651+01 EH023B 2.UVDATA.1

Freq = 8.3535 GHz, Bw = 8.000 MH No calibration applied and no bandpass applied

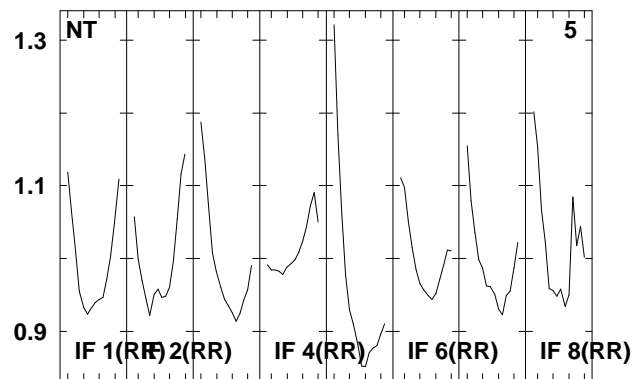
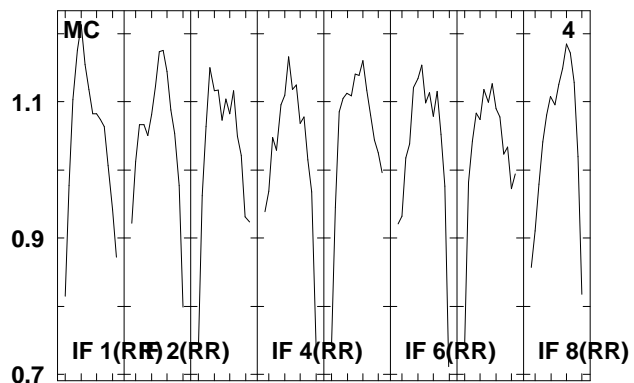
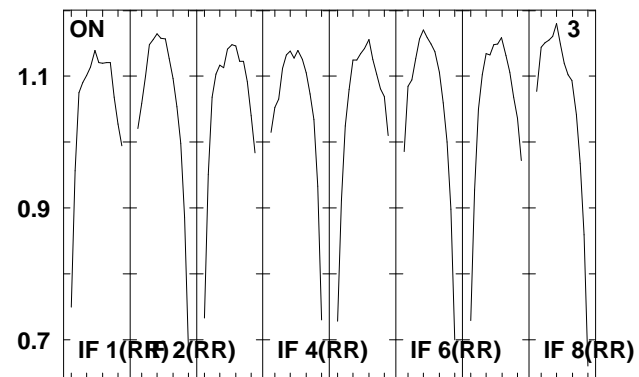
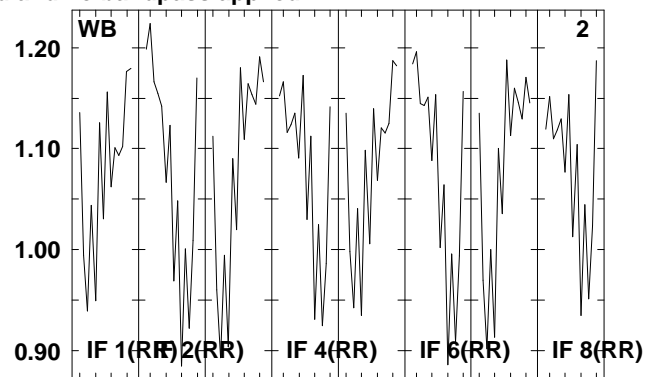
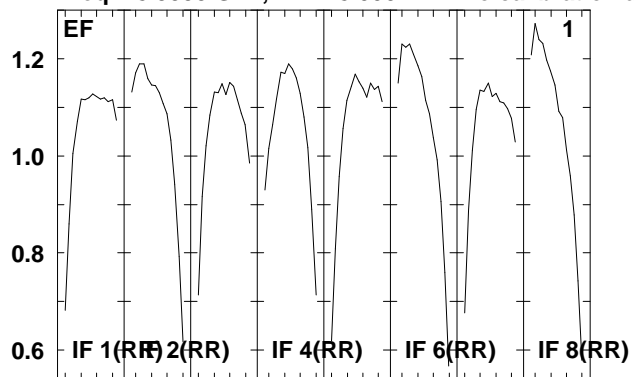

Lower frame: Real Jy  
Total-power spectrum Antenna: \*  
Timerange: 01/02:42:56 to 01/02:44:22

Plot file version 205 created 05-OCT-2009 09:28:48

NGC6240 EH023B 2.UVDATA.1

Freq = 8.3535 GHz, Bw = 8.000 MH No calibration applied and no bandpass applied

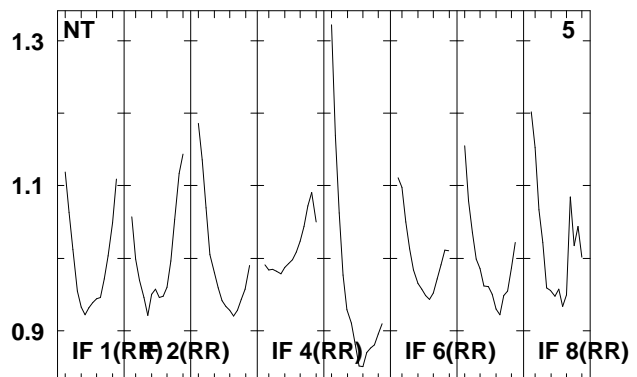
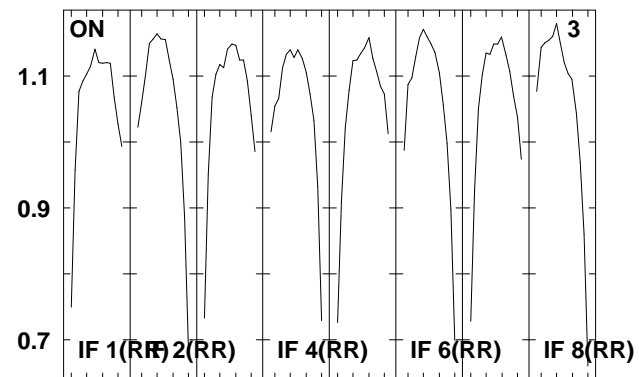
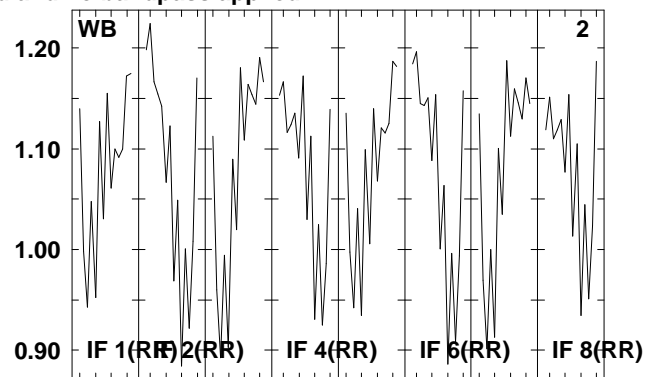
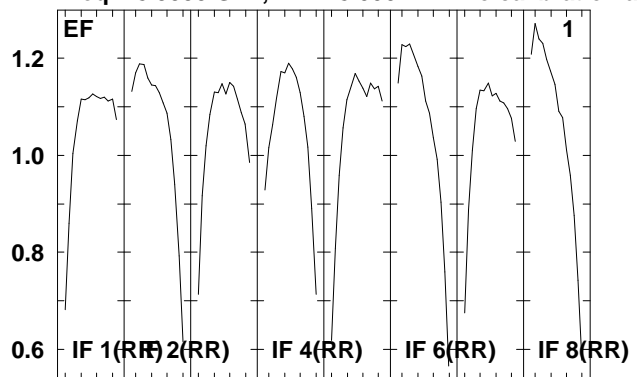

Lower frame: Real Jy  
Total-power spectrum Antenna: \*  
Timerange: 01/02:44:28 to 01/02:47:52

Plot file version 206 created 05-OCT-2009 09:28:48

J1651+01 EH023B 2.UVDATA.1

Freq = 8.3535 GHz, Bw = 8.000 MH No calibration applied and no bandpass applied

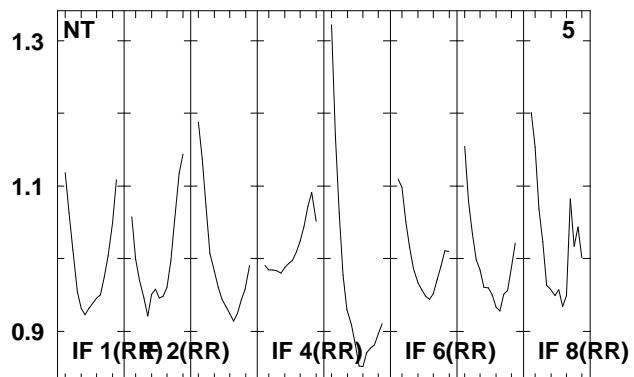
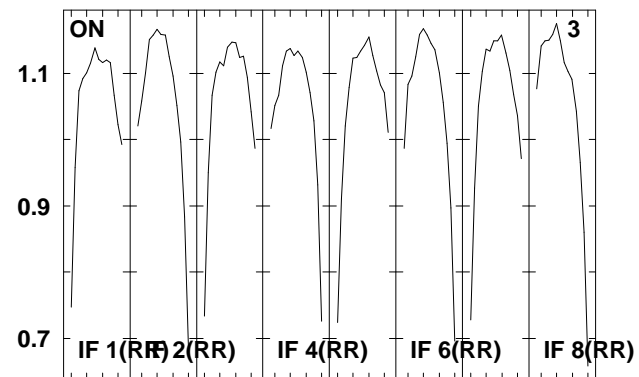
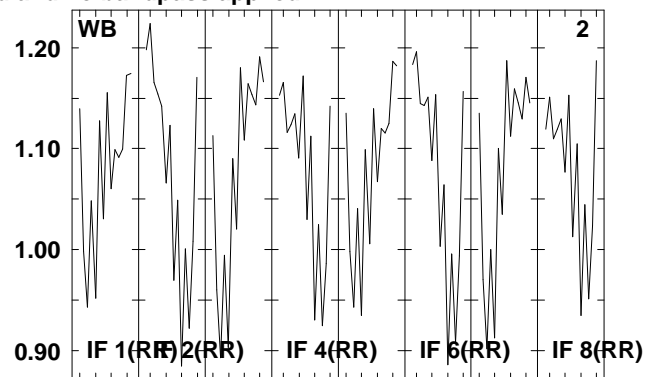
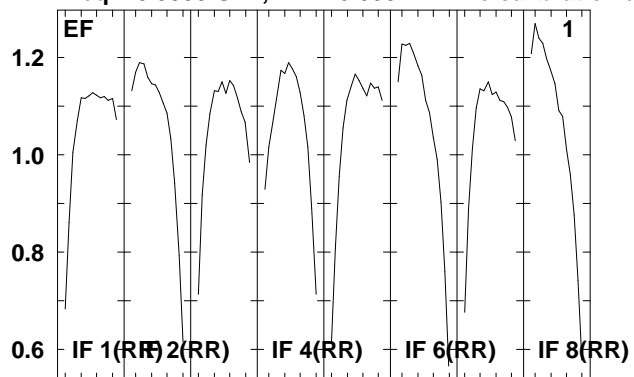

Lower frame: Real Jy  
Total-power spectrum Antenna: \*  
Timerange: 01/02:48:26 to 01/02:49:54

Plot file version 207 created 05-OCT-2009 09:28:48

3C345 EH023B 2.UVDATA.1

Freq = 8.3535 GHz, Bw = 8.000 MH No calibration applied and no bandpass applied

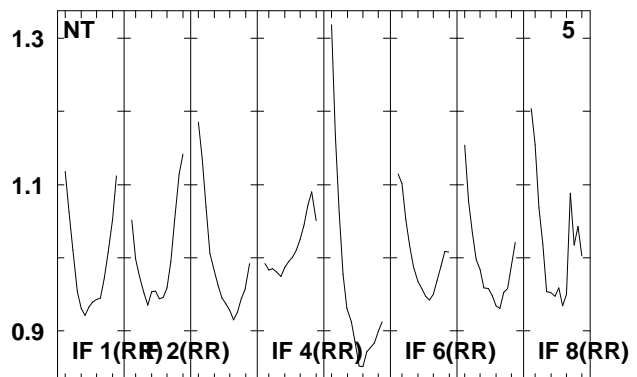
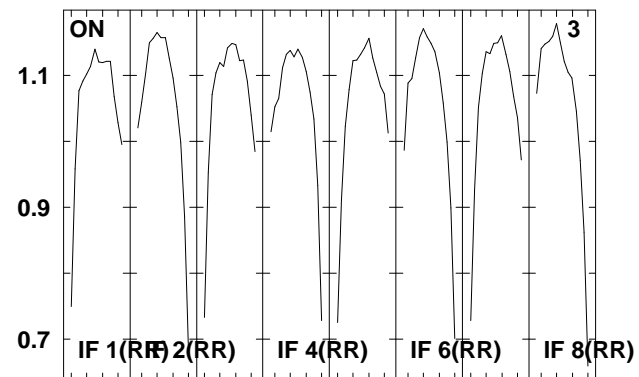
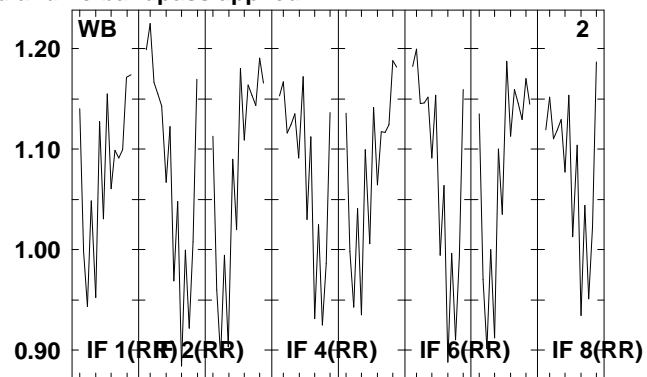
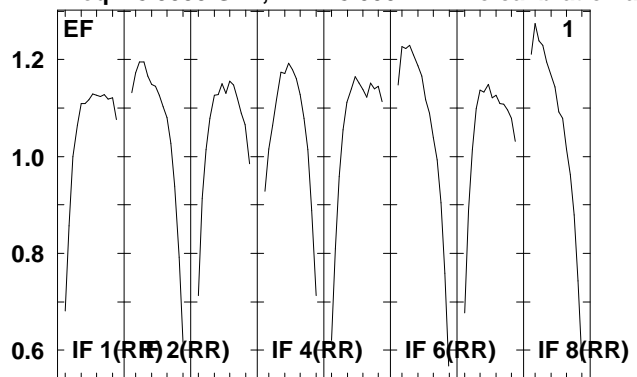

Lower frame: Real Jy  
Total-power spectrum Antenna: \*  
Timerange: 01/02:52:16 to 01/02:57:12