

Plot file version 1 created 20-NOV-2015 13:43:49

3C454.3 EO013 1.UVDATA.1

Freq = 1.3181 GHz, Bw = 32.000 MH No calibration applied and no bandpass applied

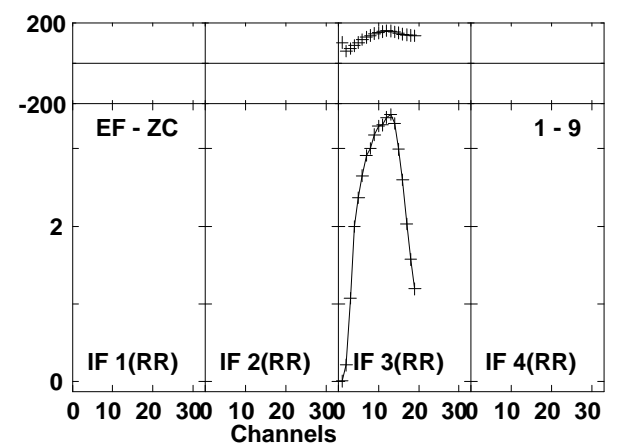
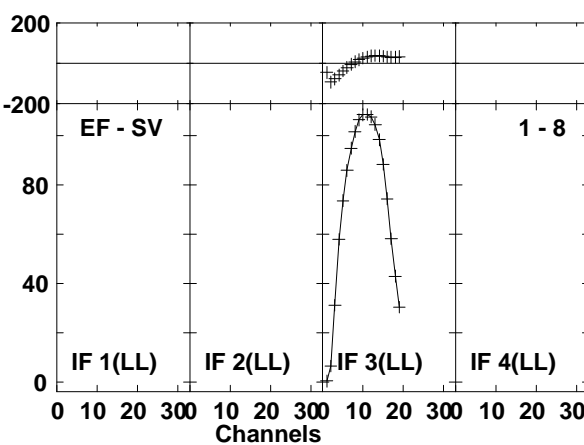
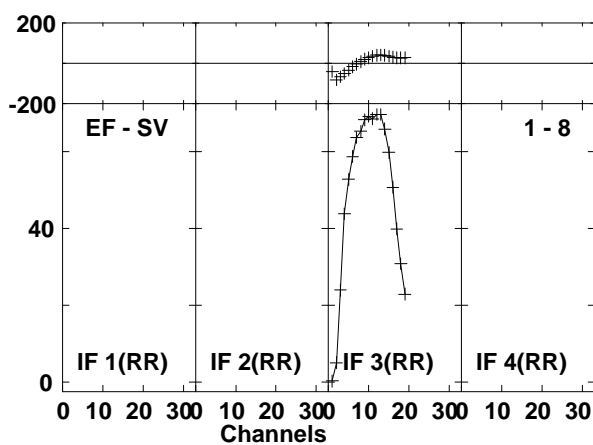
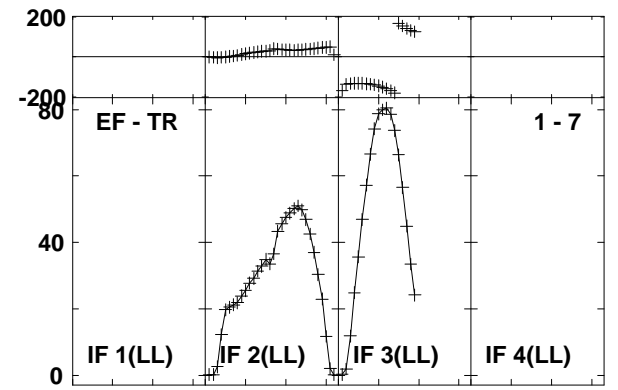
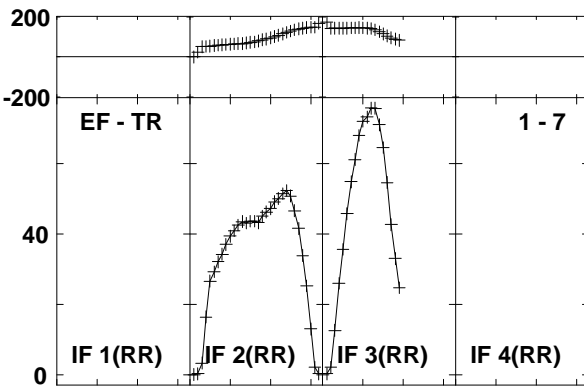
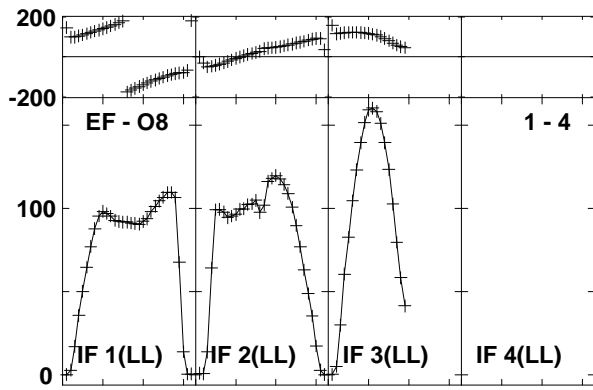
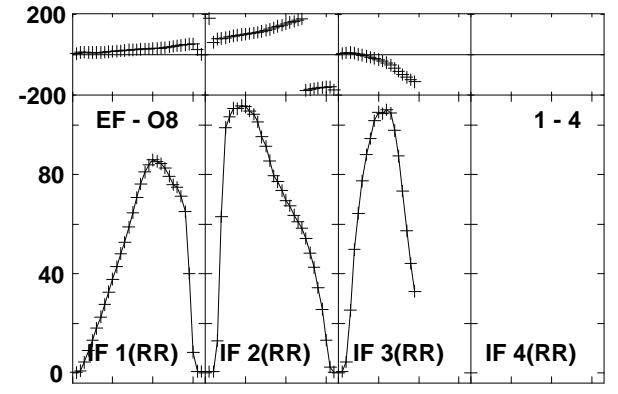
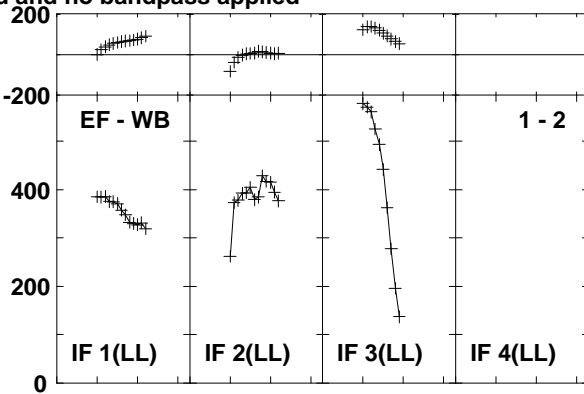
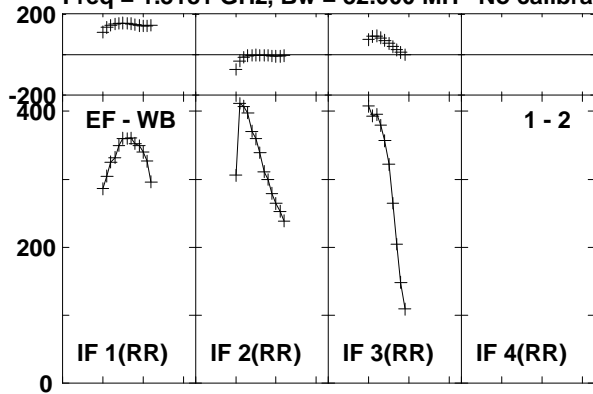

Lower frame: Milli Ampl Jy Top frame: Phas deg
Vector averaged cross-power spectrum Baseline: EF (01) - WB (02)
Timerange: 00/02:15:03 to 00/02:24:59

Plot file version 2 created 20-NOV-2015 13:43:49
 3C454.3 EO013 1.UVDATA.1
 Freq = 1.3181 GHz, Bw = 32.000 MH No calibration applied and no bandpass applied

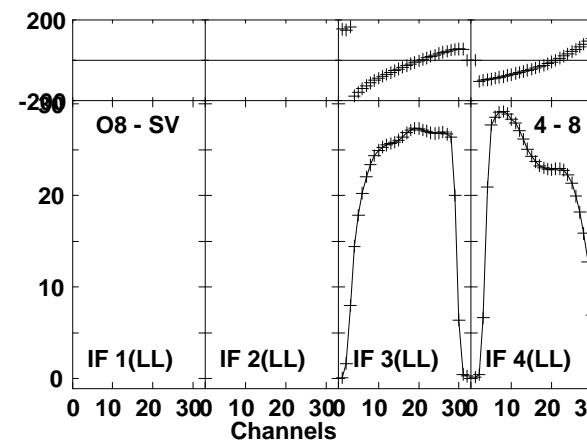
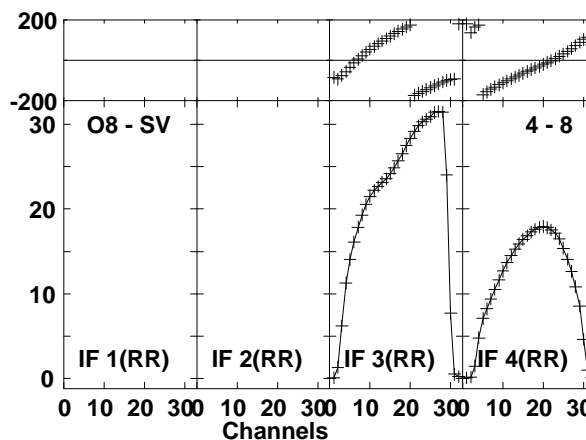
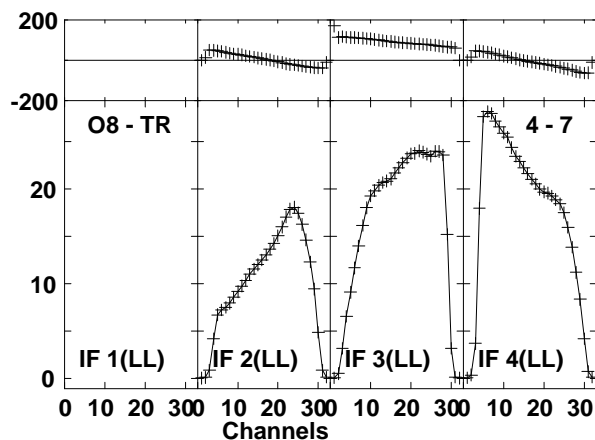
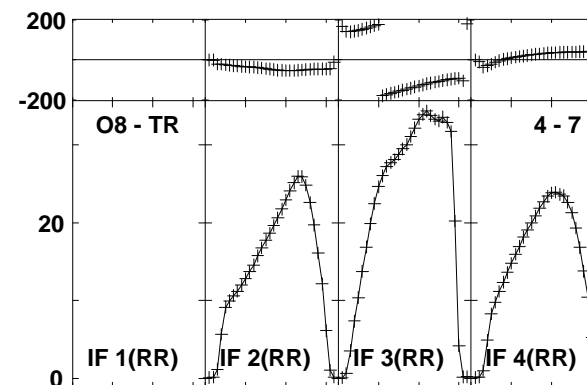
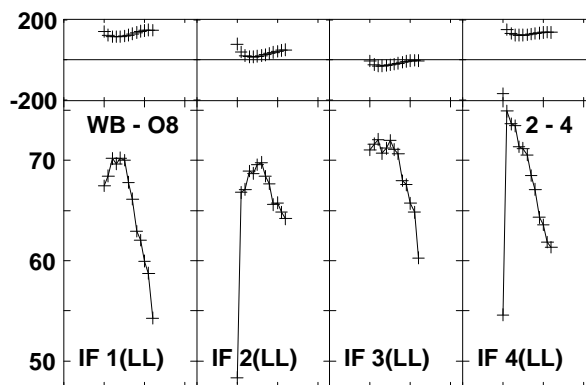
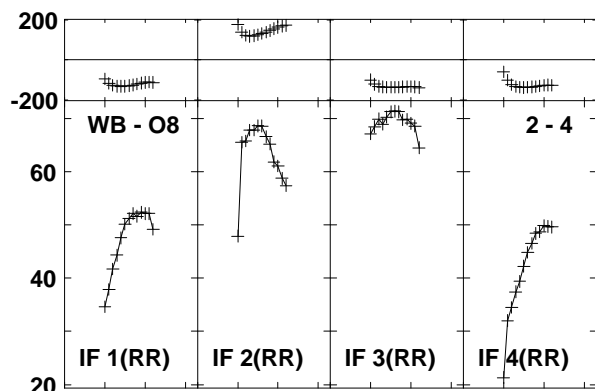
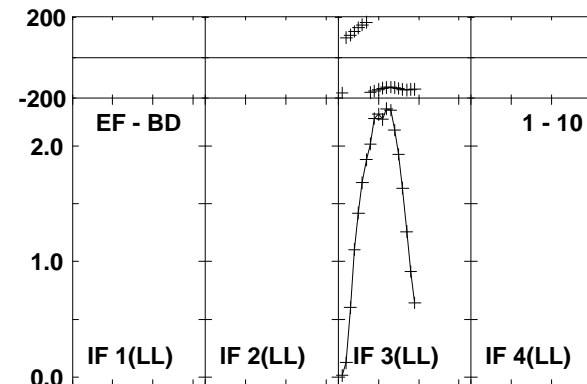
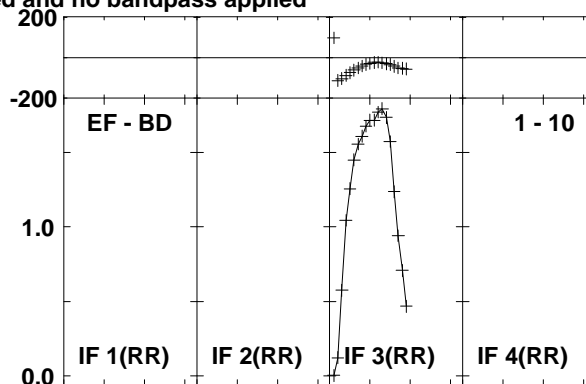
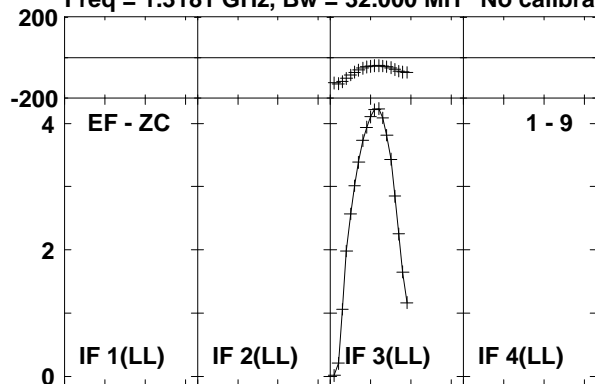

Lower frame: Milli Ampl Jy Top frame: Phas deg
 Vector averaged cross-power spectrum Baseline: EF (01) - ZC (09)
 Timerange: 00/02:15:03 to 00/02:24:59

Plot file version 3 created 20-NOV-2015 13:43:49
 3C454.3 EO013 1.UVDATA.1
 Freq = 1.3181 GHz, Bw = 32.000 MH No calibration applied and no bandpass applied

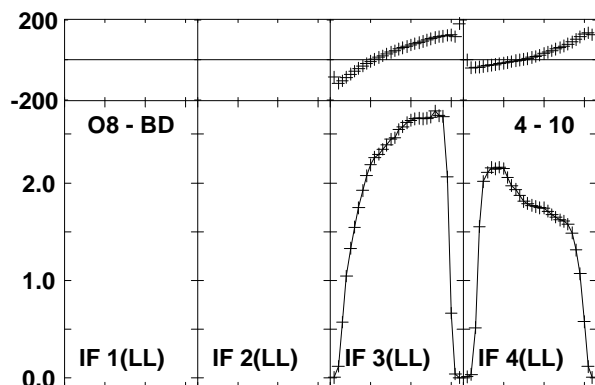
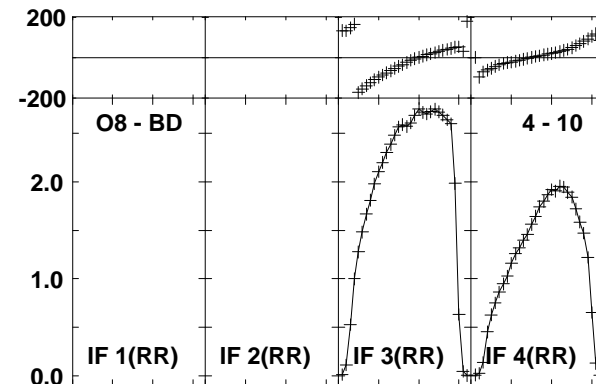
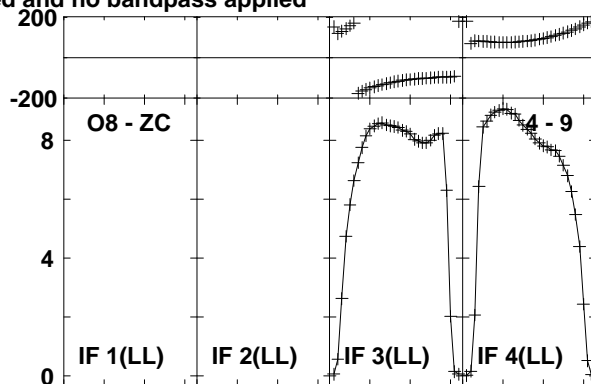
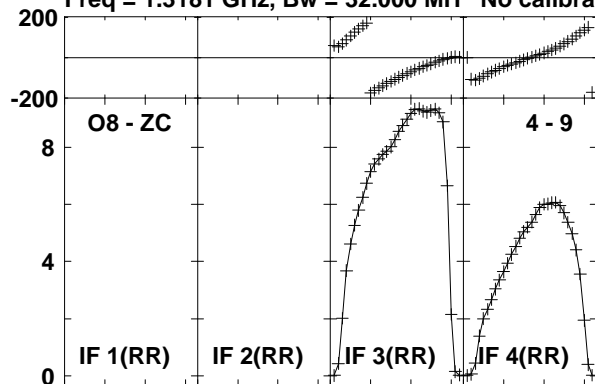

Lower frame: Milli Ampl Jy Top frame: Phas deg
 Vector averaged cross-power spectrum Baseline: O8 (04) - ZC (09)
 Timerange: 00/02:15:03 to 00/02:24:59

Plot file version 4 created 20-NOV-2015 13:43:49

3C454.3 EO013 1.UVDATA.1

Freq = 1.3181 GHz, Bw = 32.000 MH No calibration applied and no bandpass applied

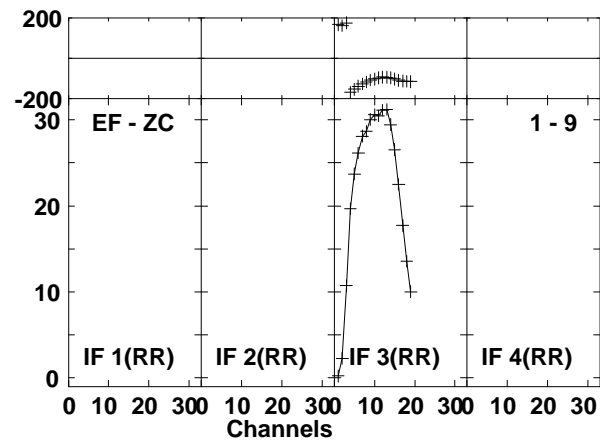
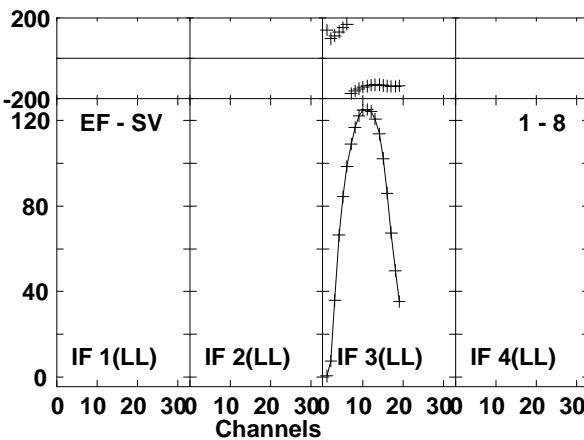
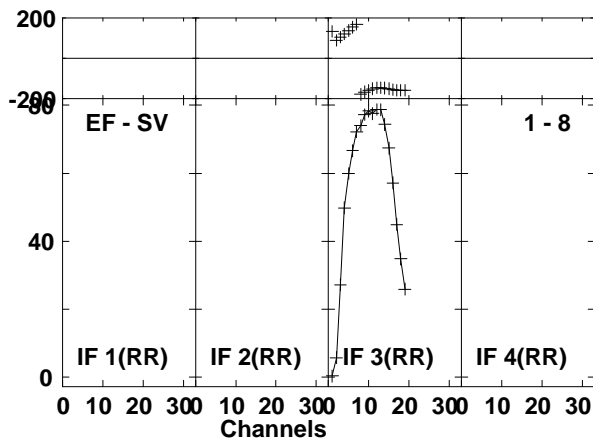
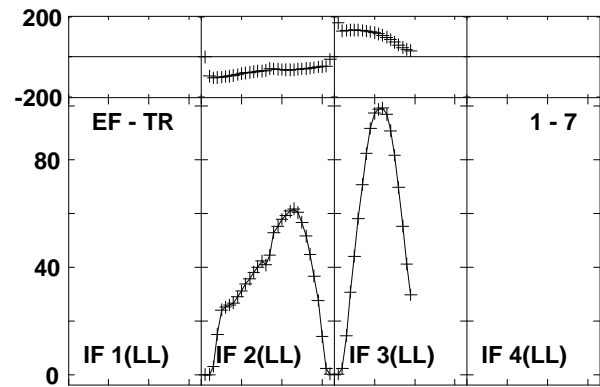
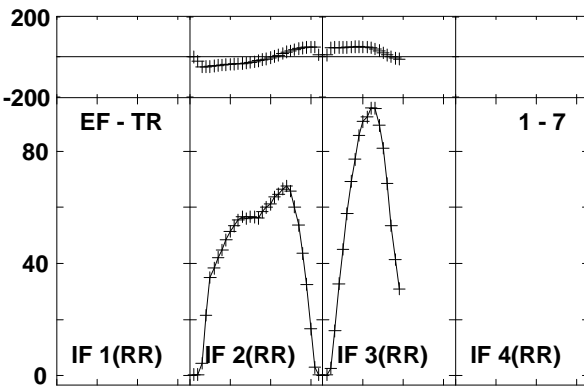
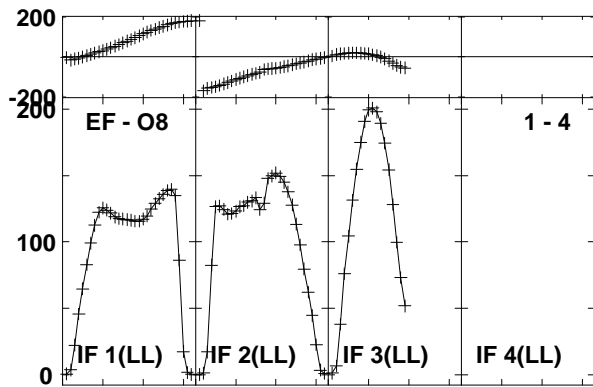
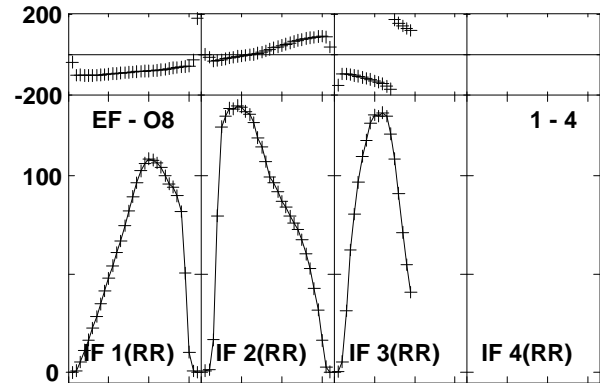
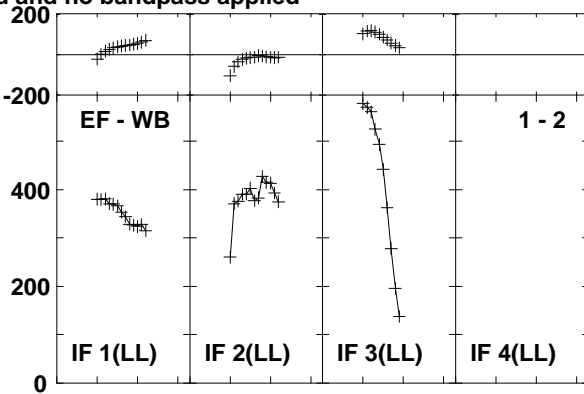
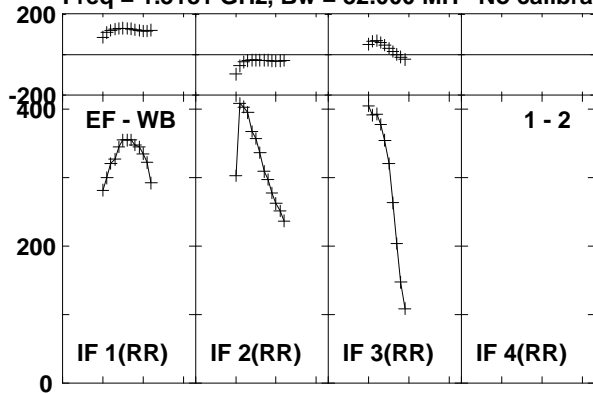

Lower frame: Milli Ampl Jy Top frame: Phas deg
Vector averaged cross-power spectrum Baseline: EF (01) - WB (02)
Timerange: 00/02:25:33 to 00/02:30:29

Plot file version 5 created 20-NOV-2015 13:43:49
 3C454.3 EO013 1.UVDATA.1
 Freq = 1.3181 GHz, Bw = 32.000 MH No calibration applied and no bandpass applied

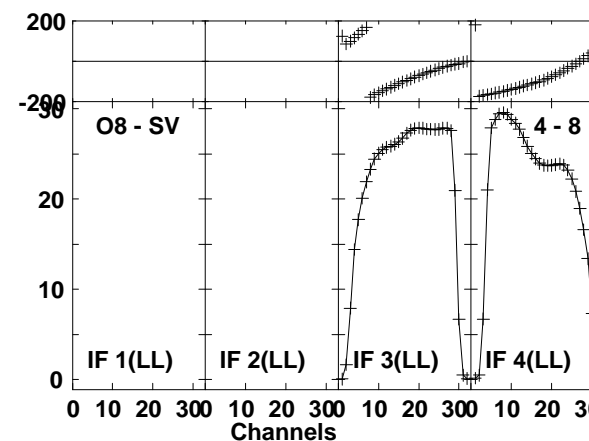
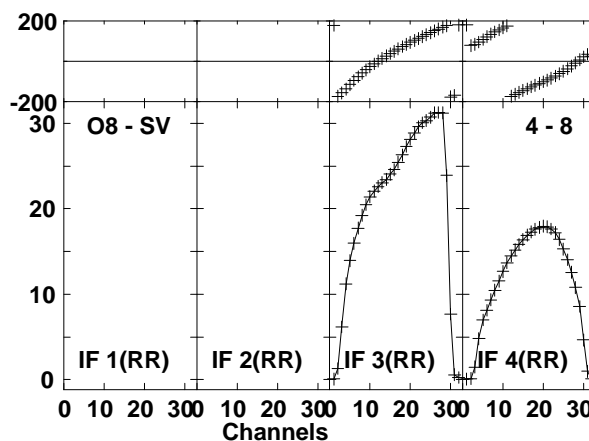
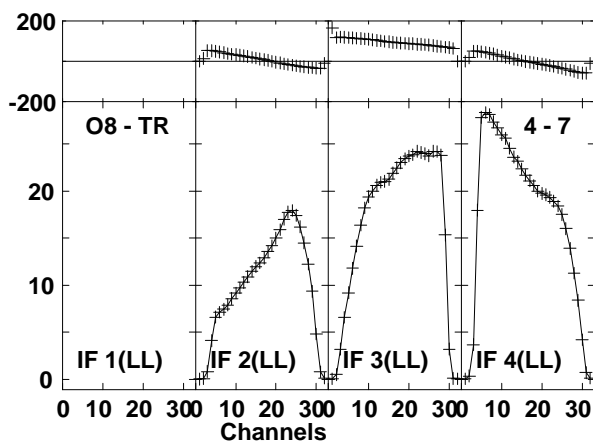
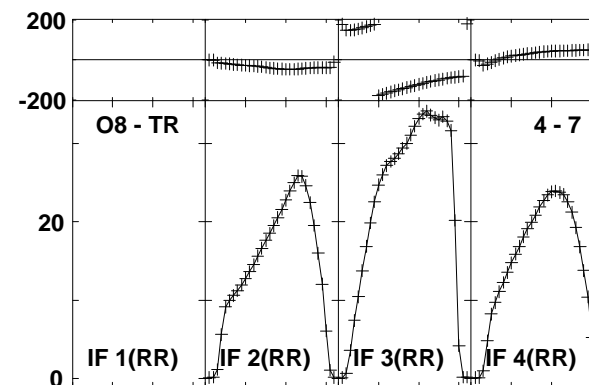
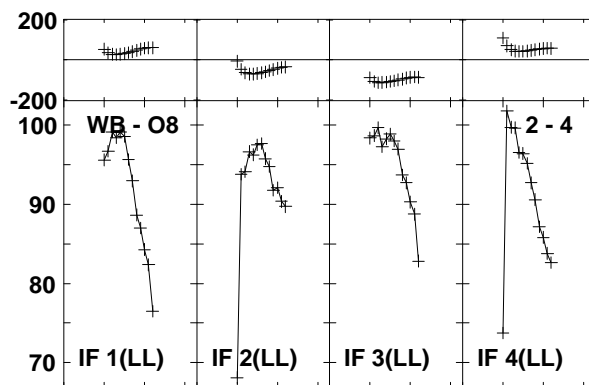
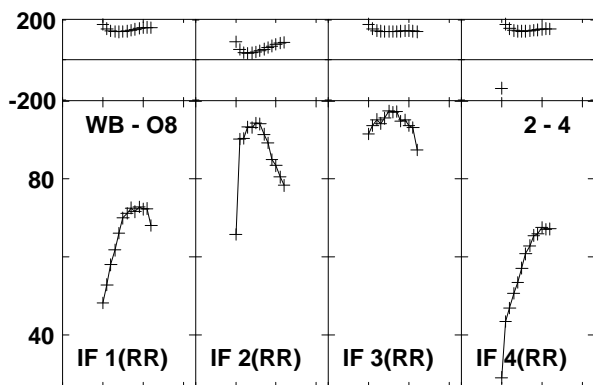
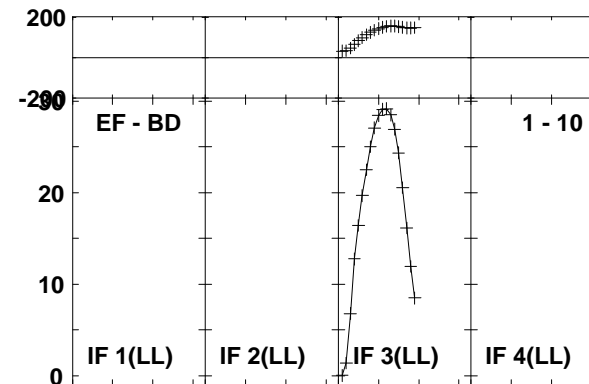
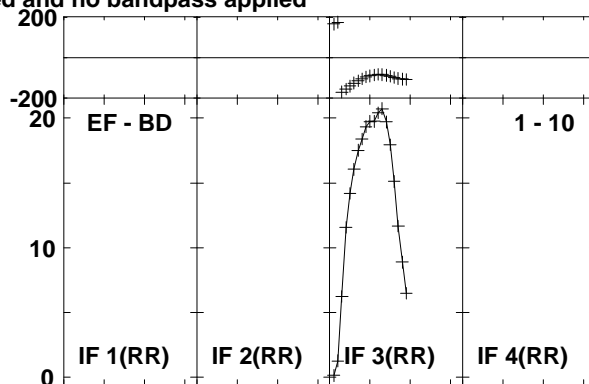
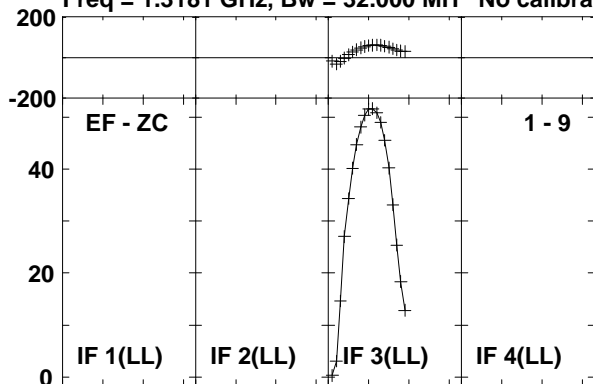

Lower frame: Milli Ampl Jy Top frame: Phas deg
 Vector averaged cross-power spectrum Baseline: EF (01) - ZC (09)
 Timerange: 00/02:25:33 to 00/02:30:29

Plot file version 6 created 20-NOV-2015 13:43:49
3C454.3 EO013 1.UVDATA.1
Freq = 1.3181 GHz, Bw = 32.000 MH No calibration applied and no bandpass applied

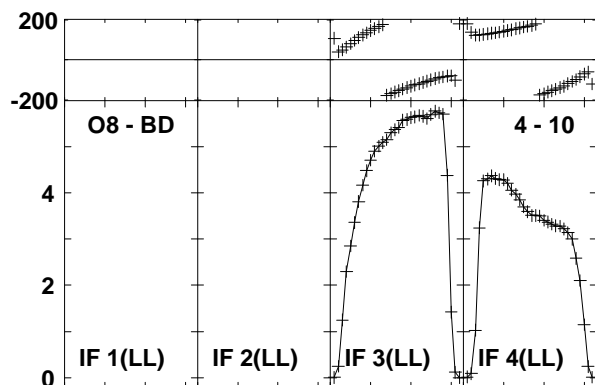
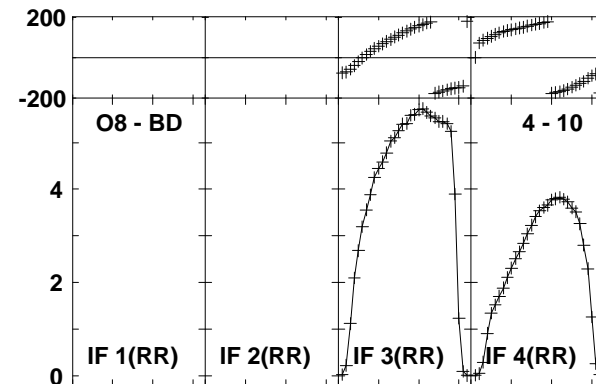
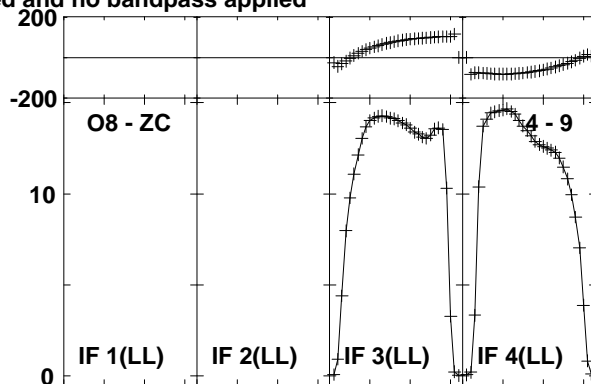
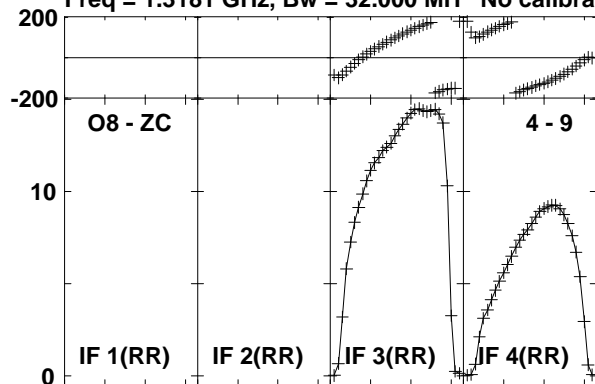

Lower frame: Milli Ampl Jy Top frame: Phas deg
Vector averaged cross-power spectrum Baseline: O8 (04) - ZC (09)
Timerange: 00/02:25:33 to 00/02:30:29

Plot file version 7 created 20-NOV-2015 13:43:49

3C84 EO013 1.UVDATA.1

Freq = 1.3181 GHz, Bw = 32.000 MH No calibration applied and no bandpass applied

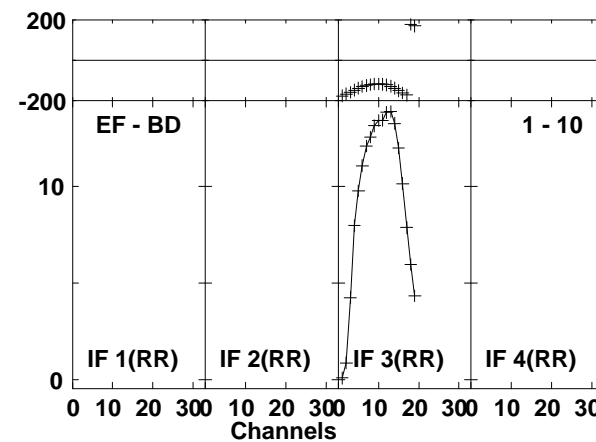
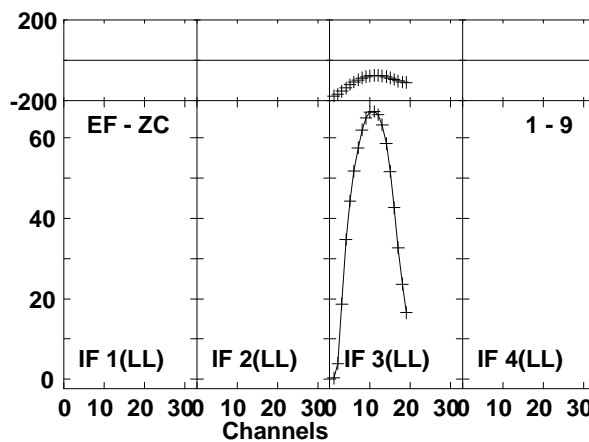
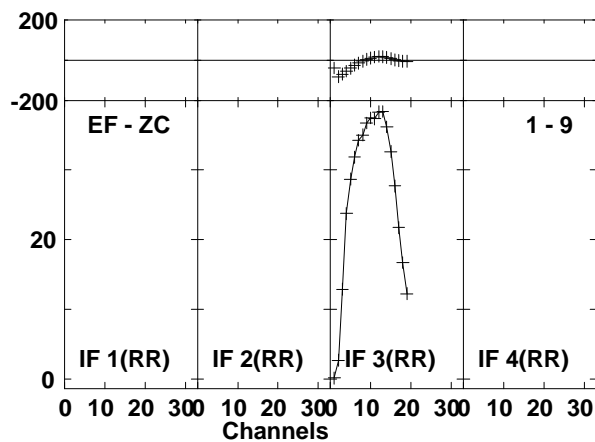
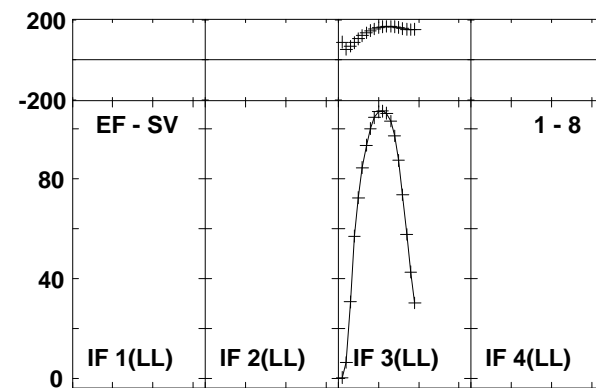
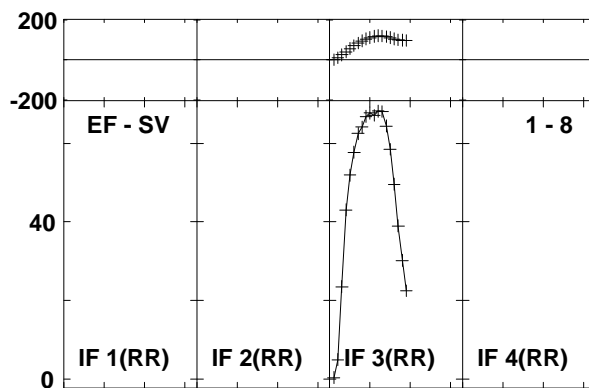
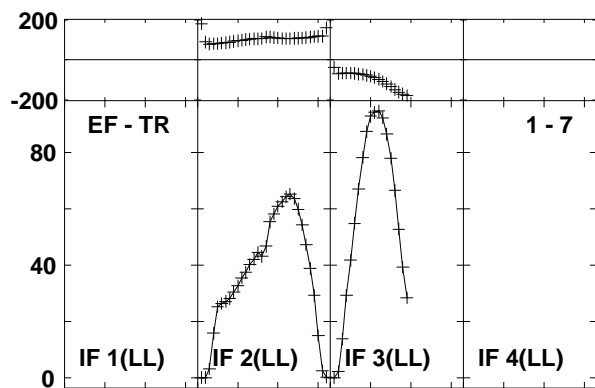
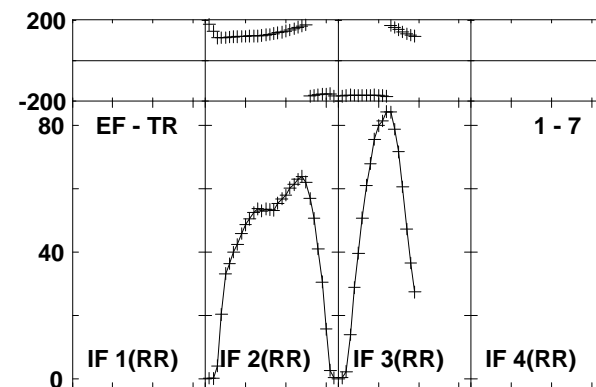
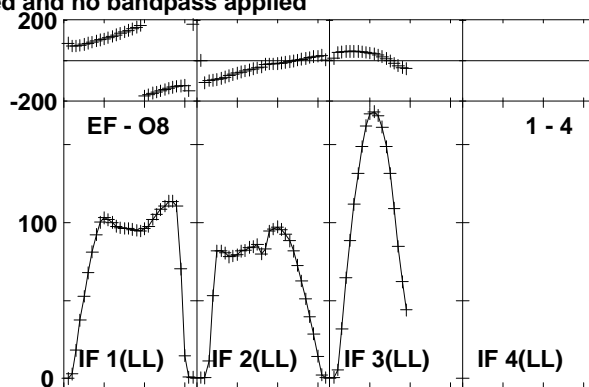
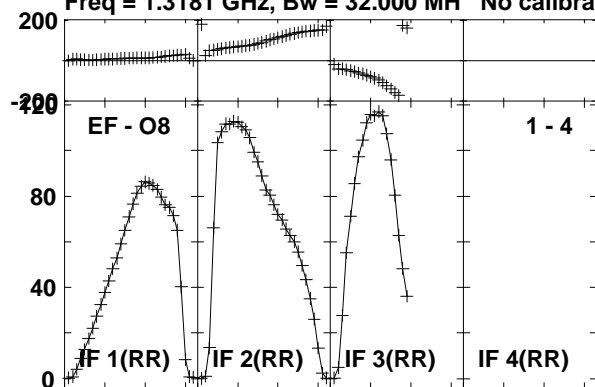

Lower frame: Milli Ampl Jy Top frame: Phas deg
Vector averaged cross-power spectrum Baseline: EF (01) - O8 (04)
Timerange: 00/02:35:33 to 00/02:45:29

Plot file version 8 created 20-NOV-2015 13:43:49
 3C84 EO013 1.UVDATA.1
 Freq = 1.3181 GHz, Bw = 32.000 MH No calibration applied and no bandpass applied

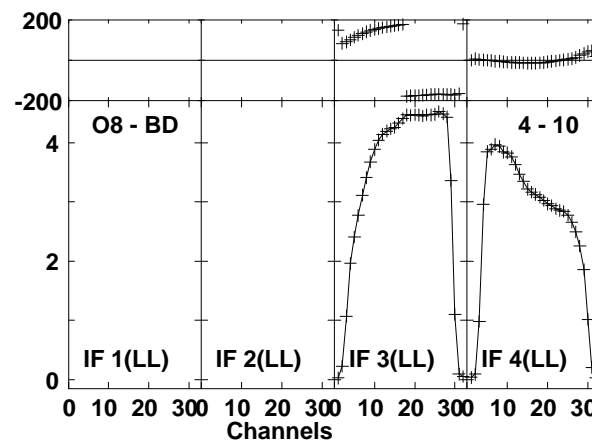
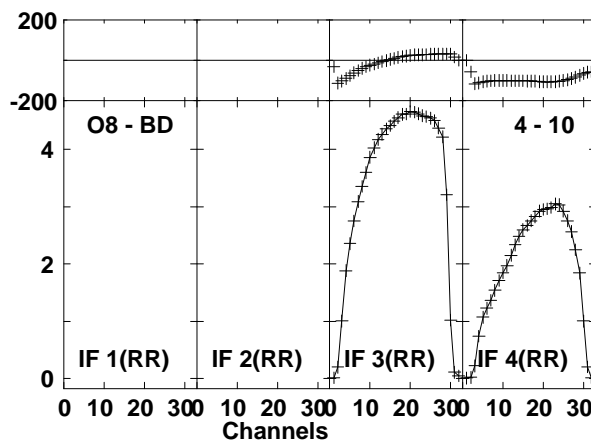
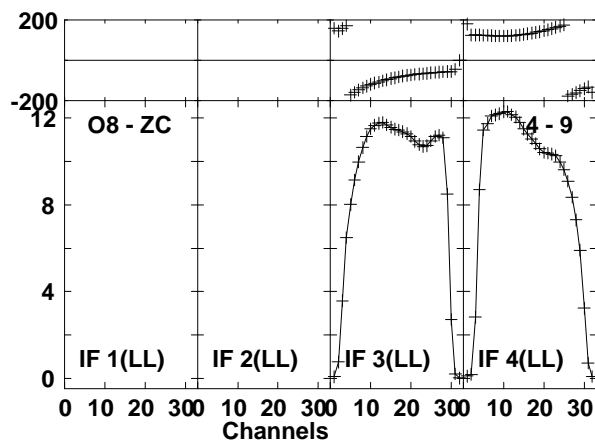
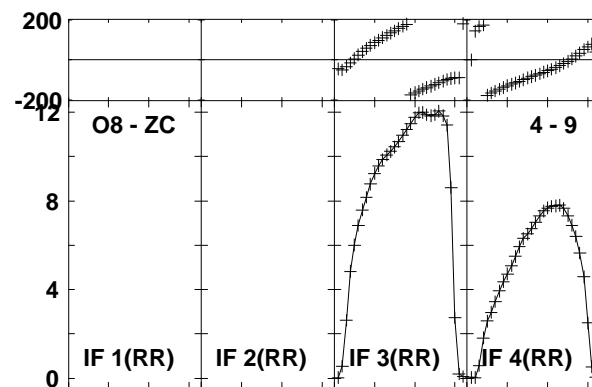
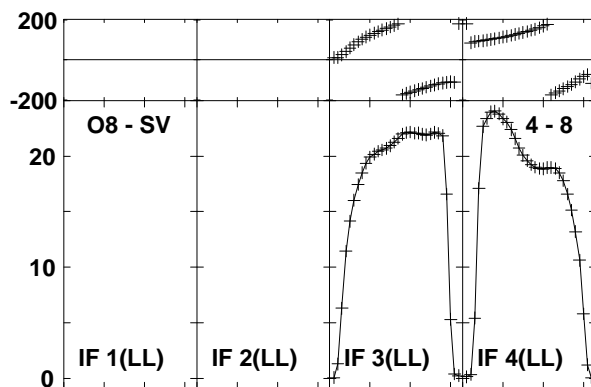
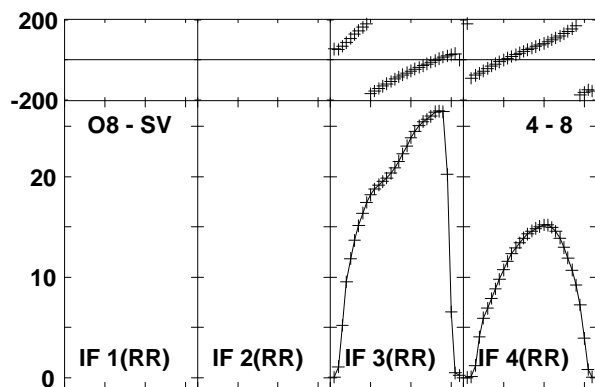
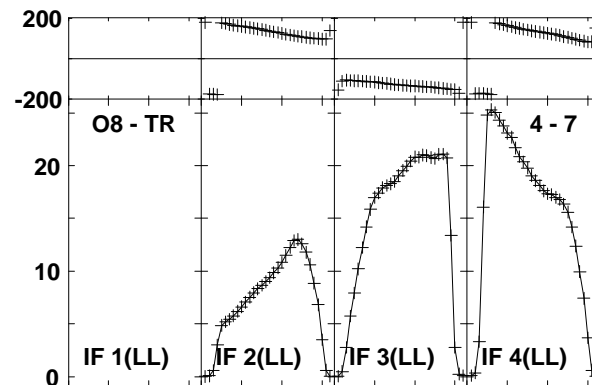
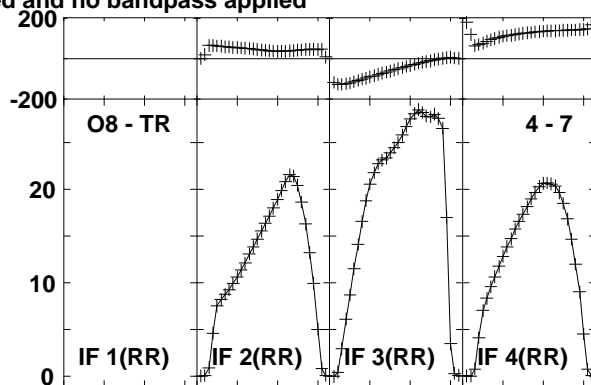
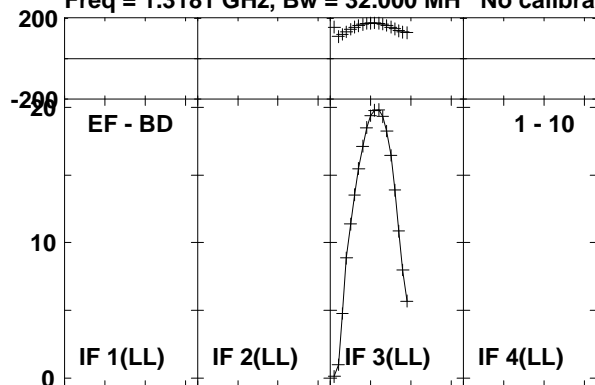

Lower frame: Milli Ampl Jy Top frame: Phas deg
 Vector averaged cross-power spectrum Baseline: EF (01) - BD (10)
 Timerange: 00/02:35:33 to 00/02:45:29

Plot file version 9 created 20-NOV-2015 13:43:49

3C84 EO013 1.UVDATA.1

Freq = 1.3181 GHz, Bw = 32.000 MH No calibration applied and no bandpass applied

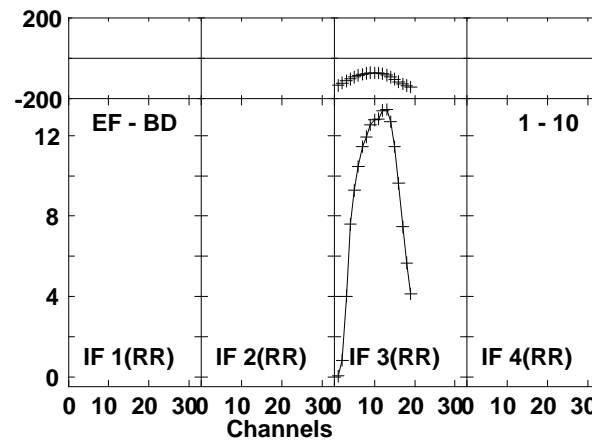
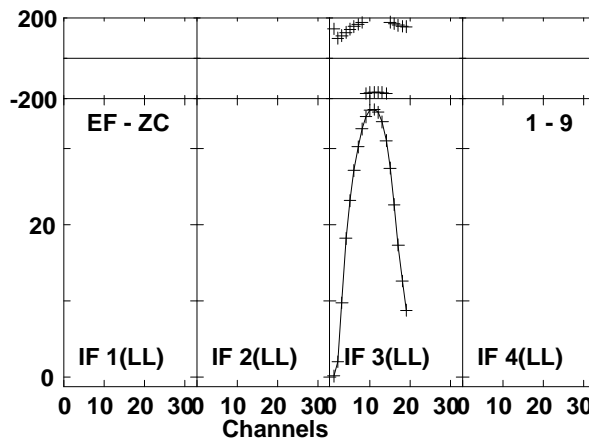
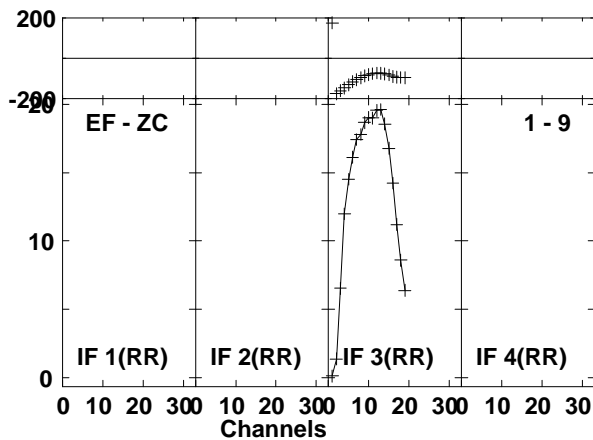
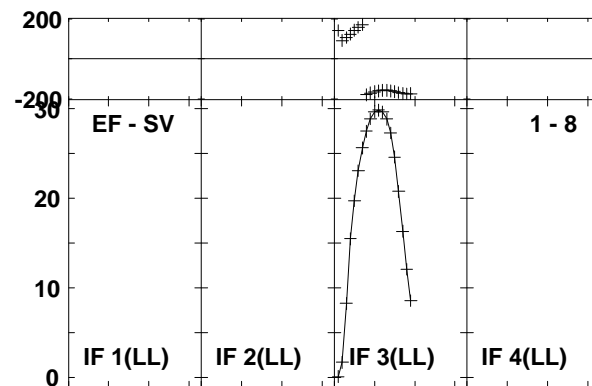
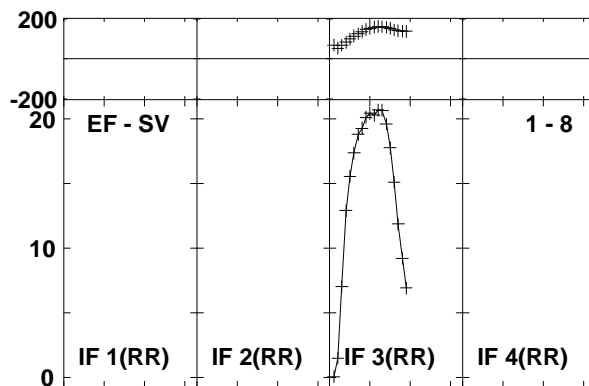
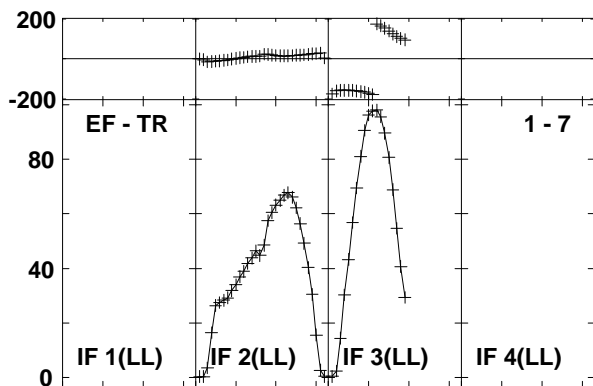
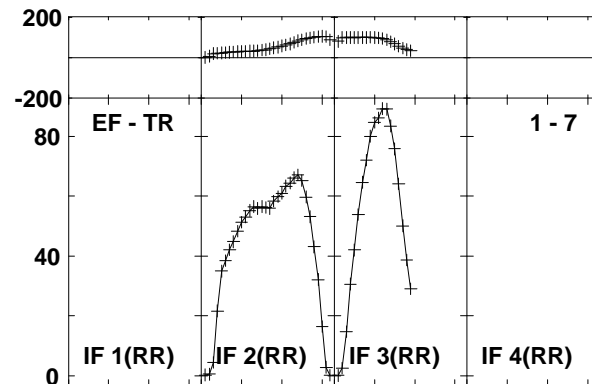
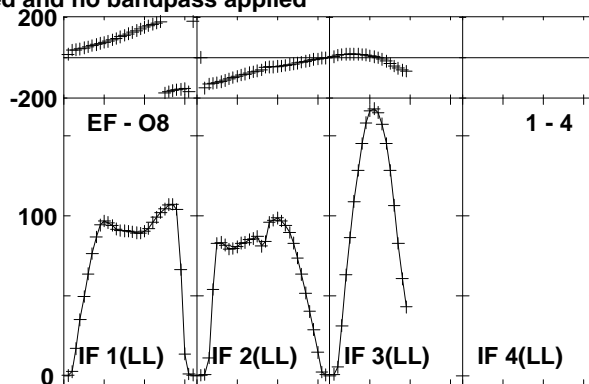
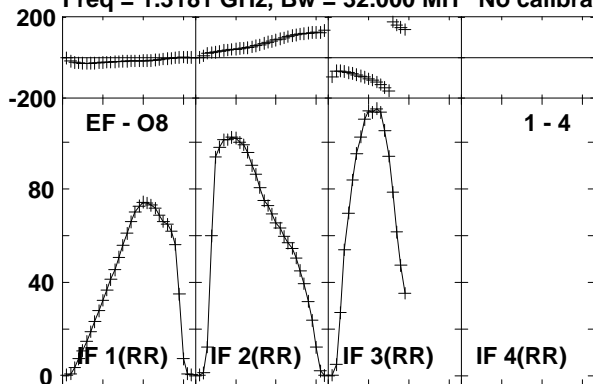

Lower frame: Milli Ampl Jy Top frame: Phas deg
Vector averaged cross-power spectrum Baseline: EF (01) - O8 (04)
Timerange: 00/02:46:03 to 00/02:55:59

Plot file version 10 created 20-NOV-2015 13:43:49
 3C84 EO013 1.UVDATA.1
 Freq = 1.3181 GHz, Bw = 32.000 MH No calibration applied and no bandpass applied

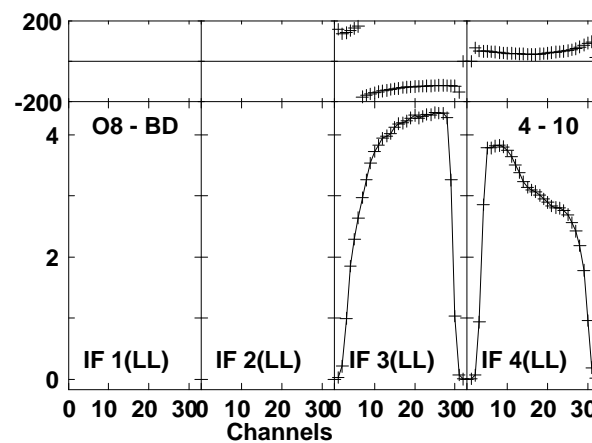
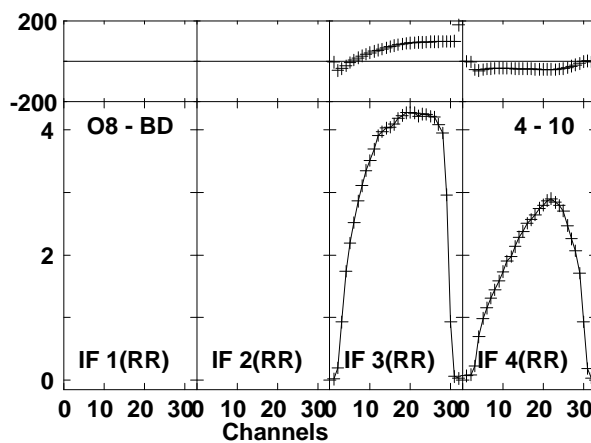
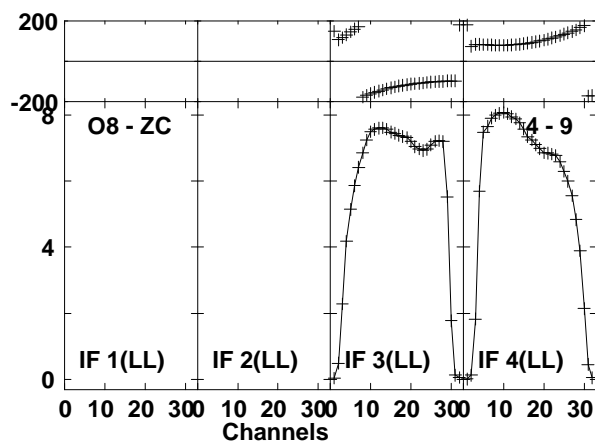
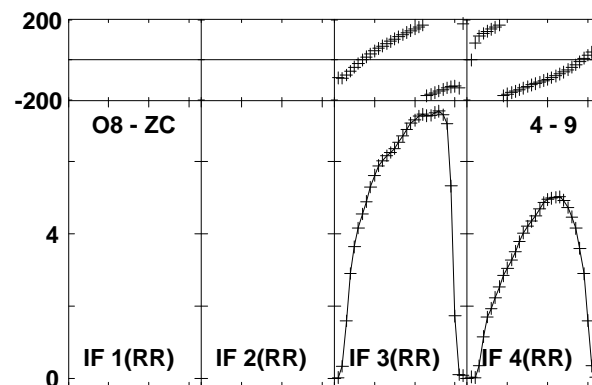
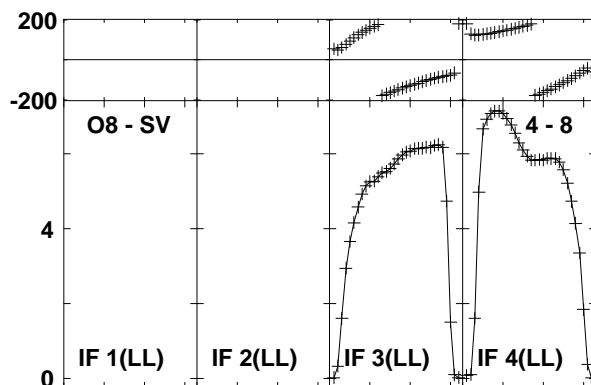
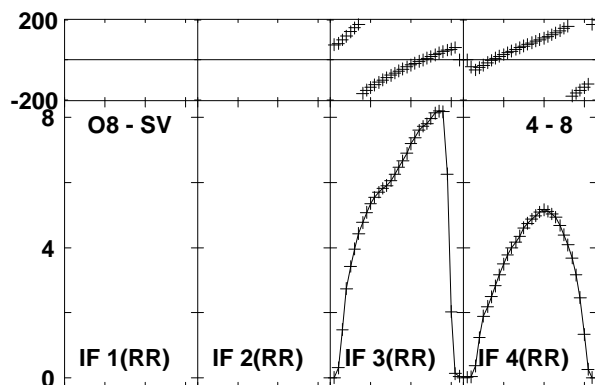
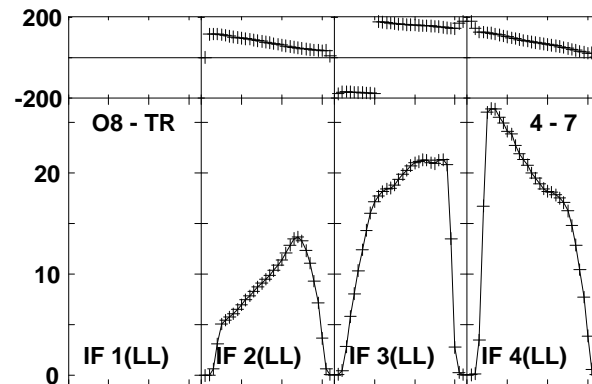
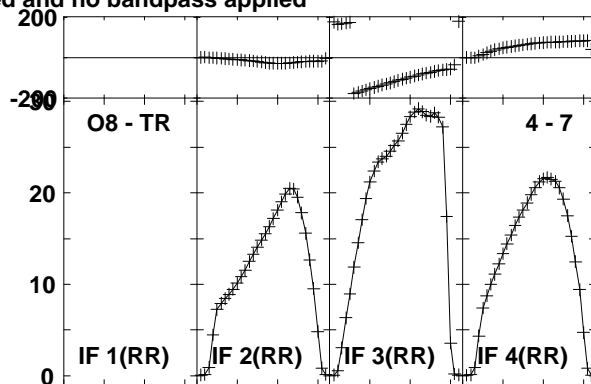
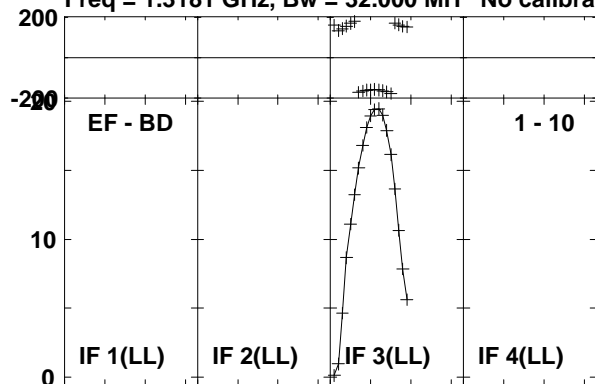

Lower frame: Milli Ampl Jy Top frame: Phas deg
 Vector averaged cross-power spectrum Baseline: EF (01) - BD (10)
 Timerange: 00/02:46:03 to 00/02:55:59

Plot file version 11 created 20-NOV-2015 13:43:50

3C84 EO013 1.UVDATA.1

Freq = 1.3181 GHz, Bw = 32.000 MH No calibration applied and no bandpass applied

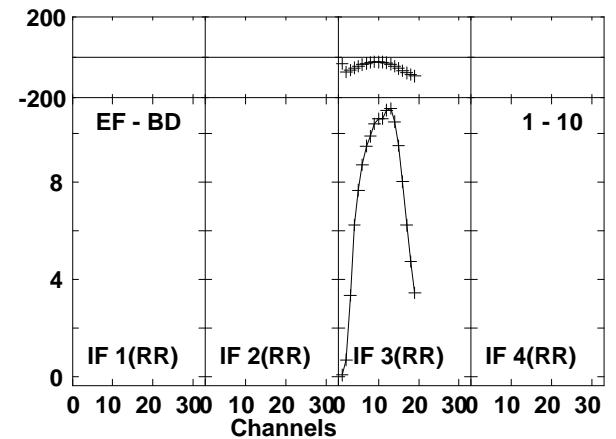
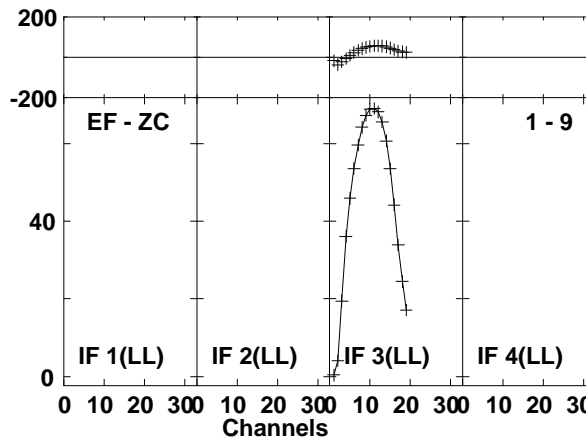
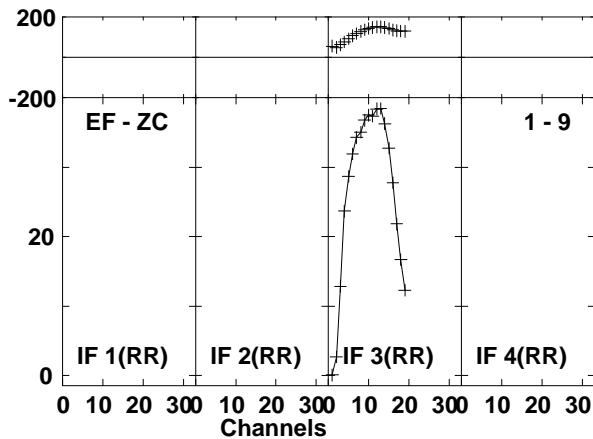
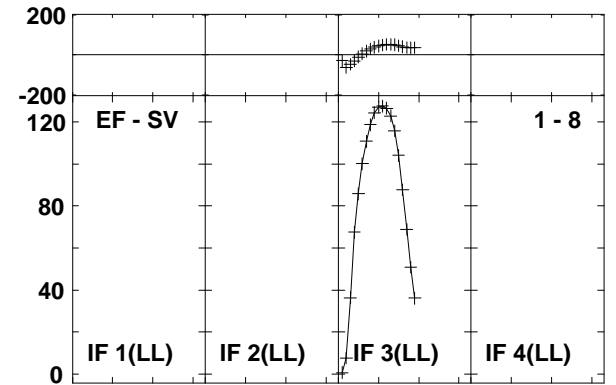
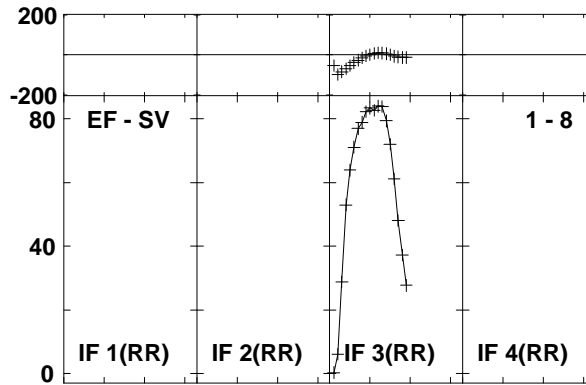
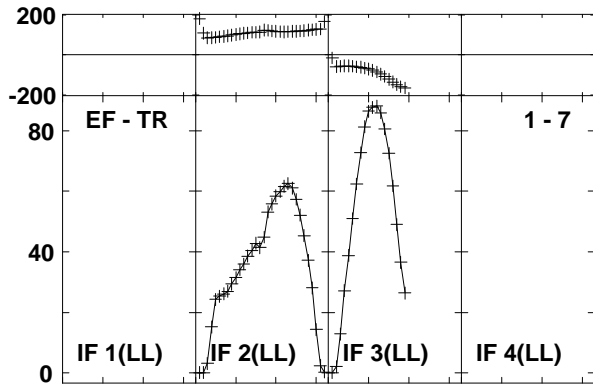
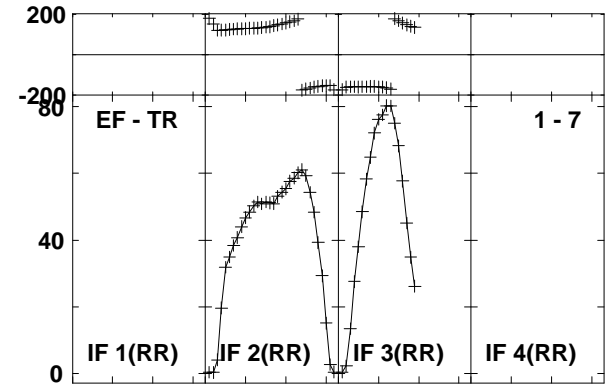
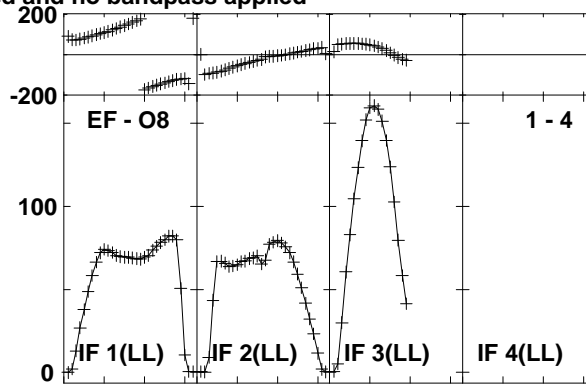
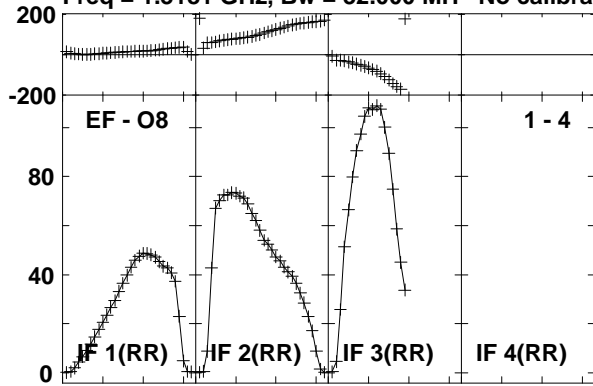

Lower frame: Milli Ampl Jy Top frame: Phas deg
Vector averaged cross-power spectrum Baseline: EF (01) - O8 (04)
Timerange: 00/02:56:33 to 00/03:06:29

Plot file version 12 created 20-NOV-2015 13:43:50

3C84 EO013 1.UVDATA.1

Freq = 1.3181 GHz, Bw = 32.000 MH No calibration applied and no bandpass applied

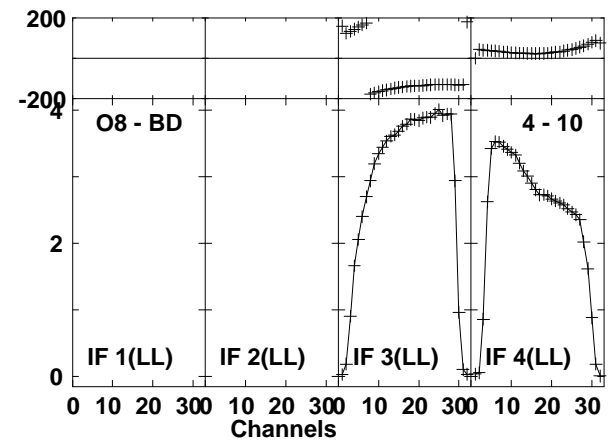
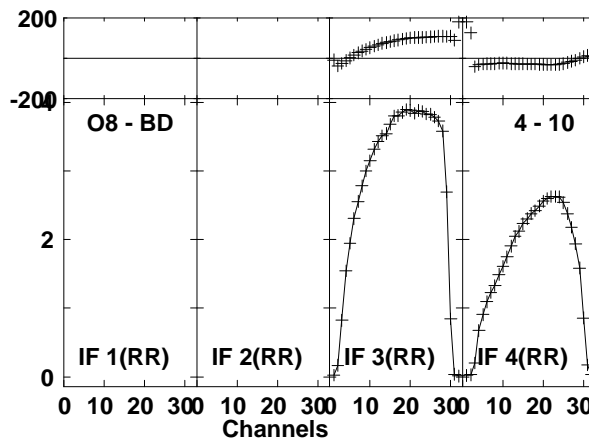
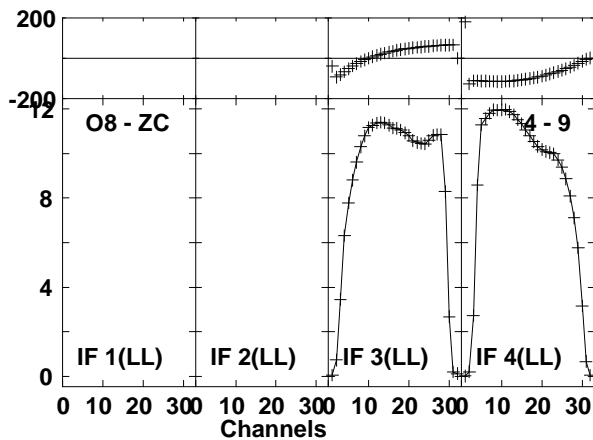
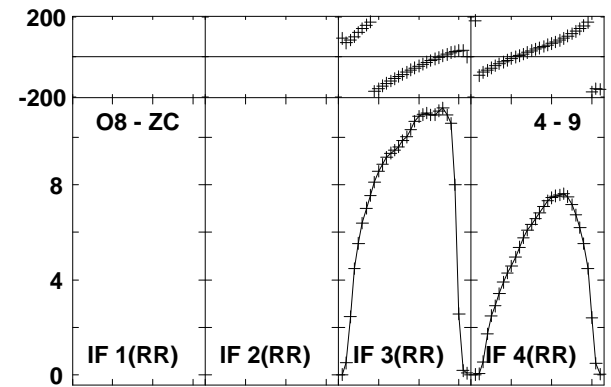
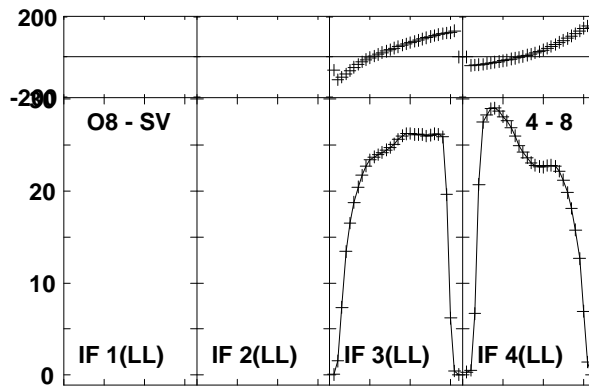
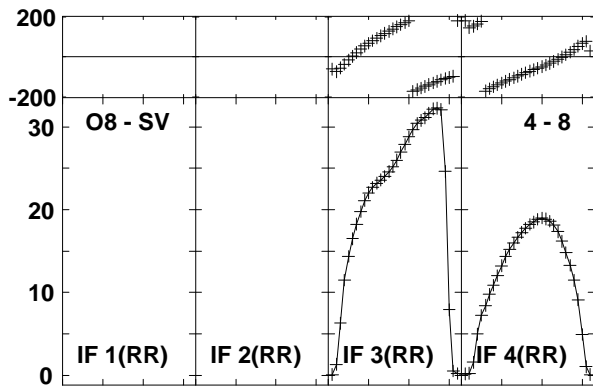
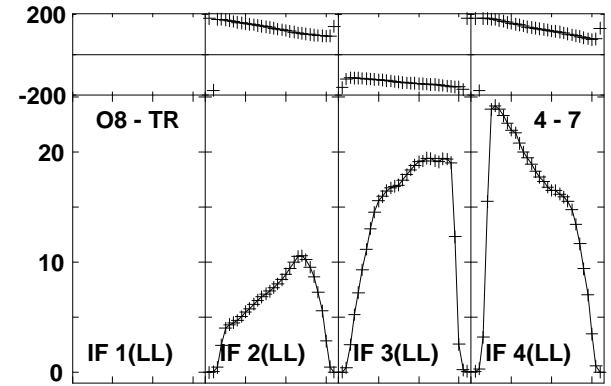
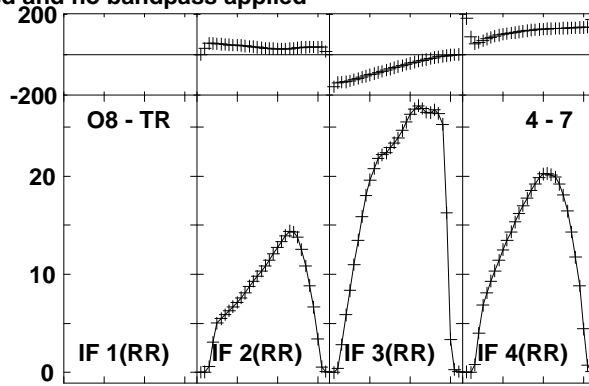
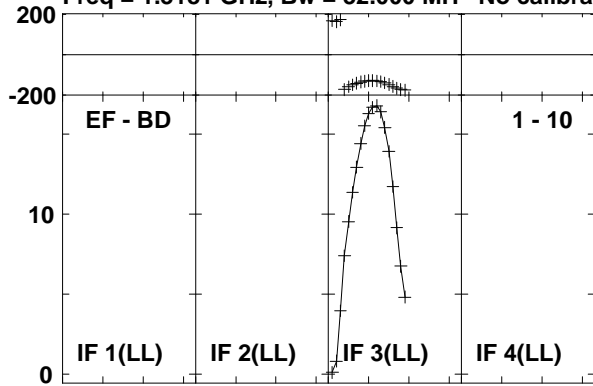

Lower frame: Milli Ampl Jy Top frame: Phas deg
Vector averaged cross-power spectrum Baseline: EF (01) - BD (10)
Timerange: 00/02:56:33 to 00/03:06:29

Plot file version 13 created 20-NOV-2015 13:43:50

3C84 EO013 1.UVDATA.1

Freq = 1.3181 GHz, Bw = 32.000 MH No calibration applied and no bandpass applied

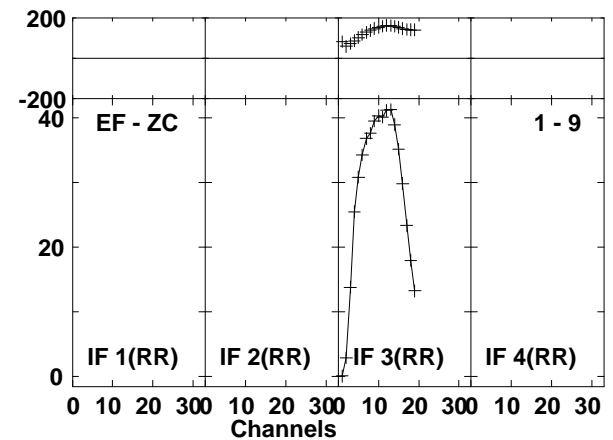
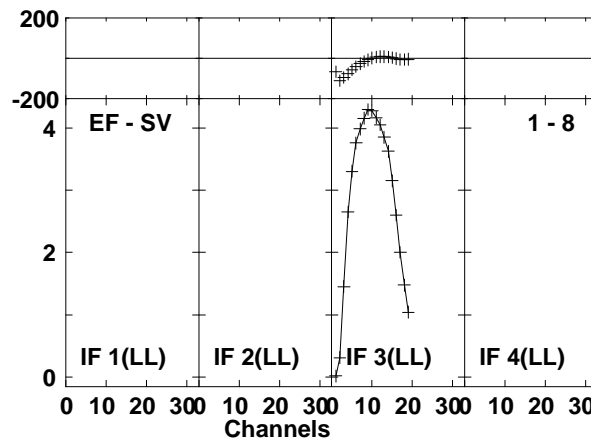
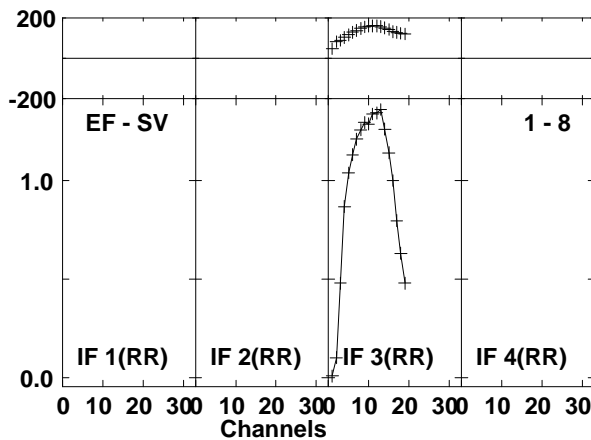
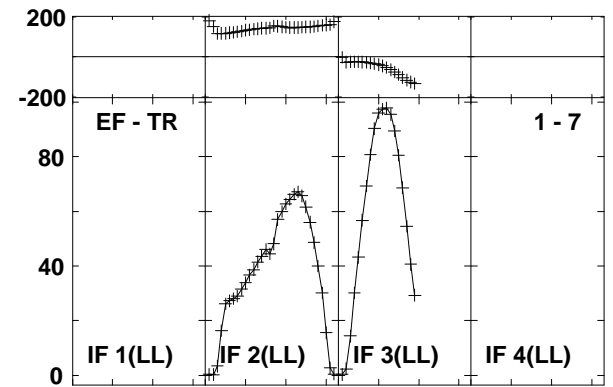
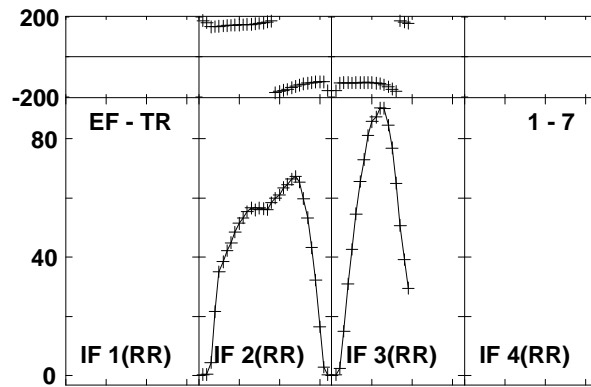
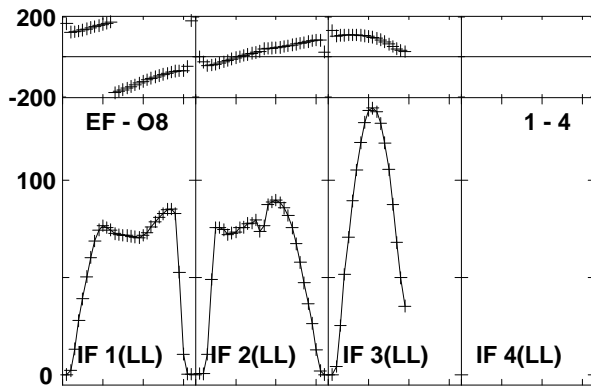
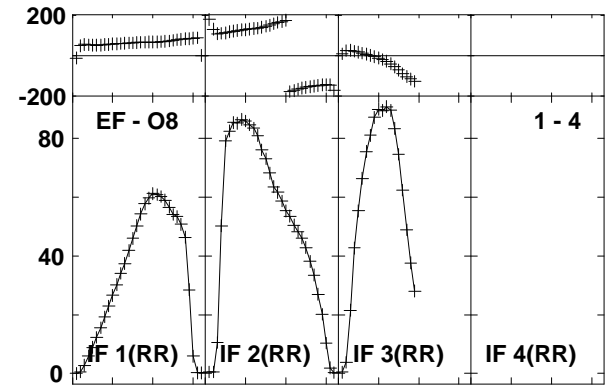
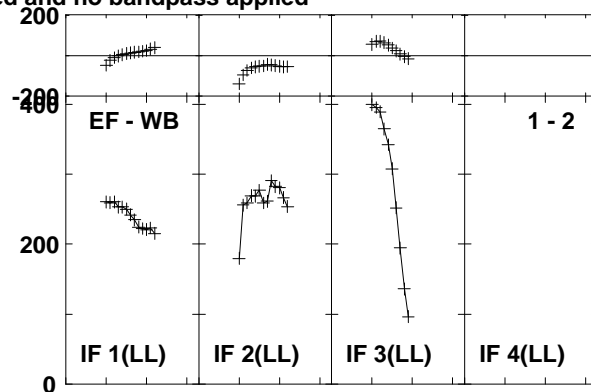
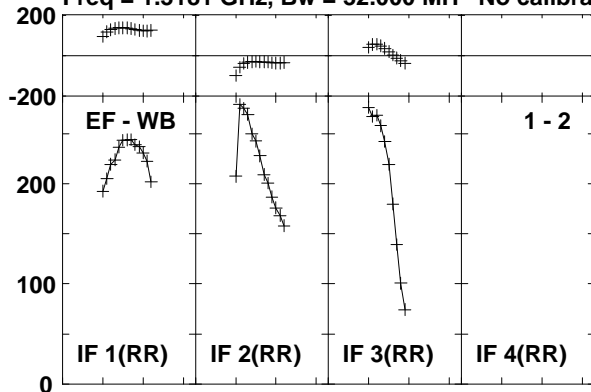

Lower frame: Milli Ampl Jy Top frame: Phas deg
Vector averaged cross-power spectrum Baseline: EF (01) - WB (02)
Timerange: 00/03:07:03 to 00/03:16:59

Plot file version 14 created 20-NOV-2015 13:43:50

3C84 EO013 1.UVDATA.1

Freq = 1.3181 GHz, Bw = 32.000 MH No calibration applied and no bandpass applied

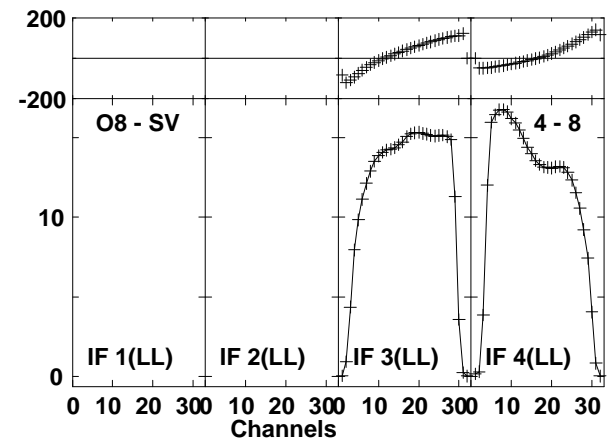
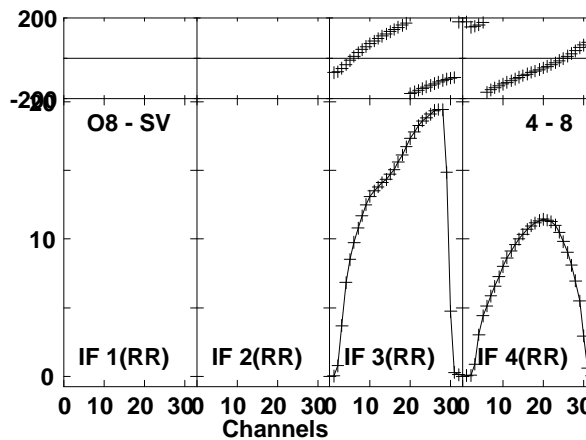
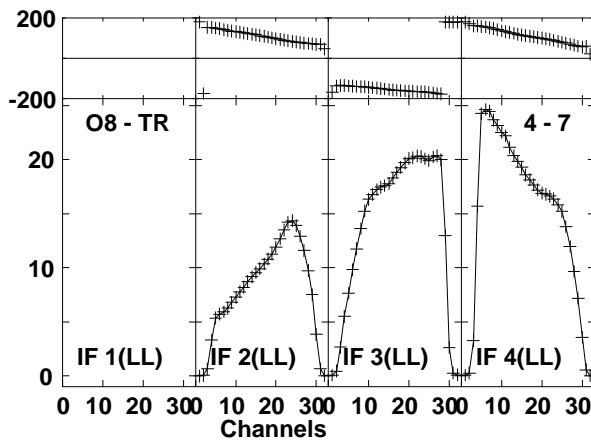
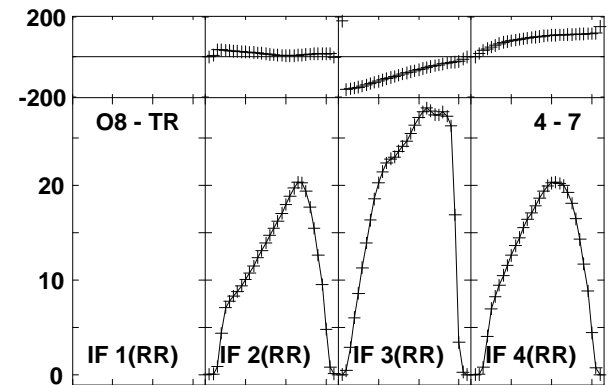
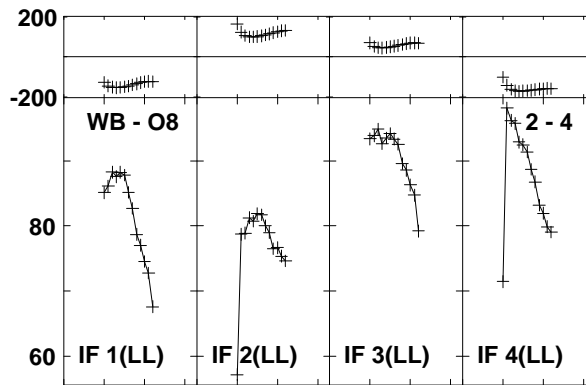
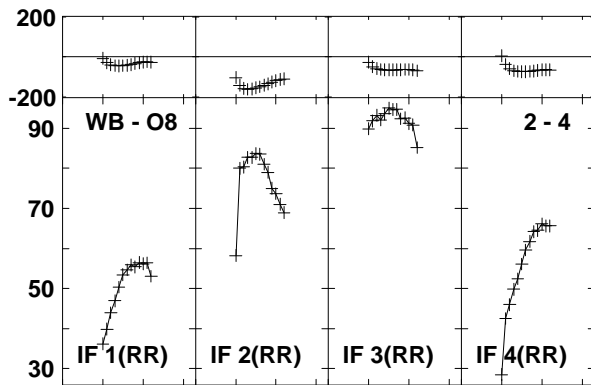
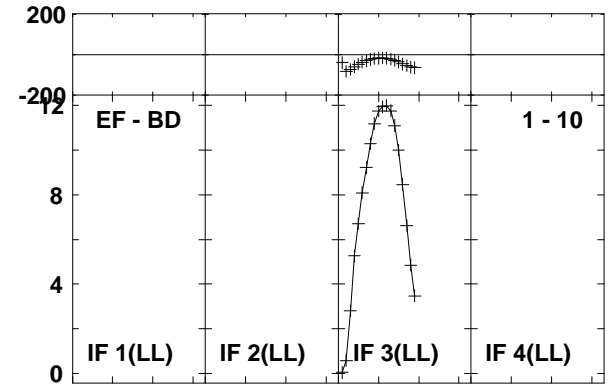
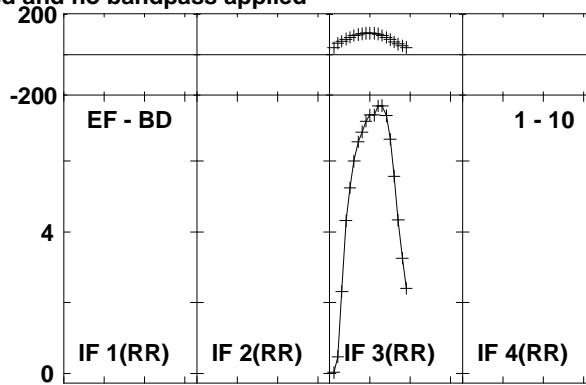
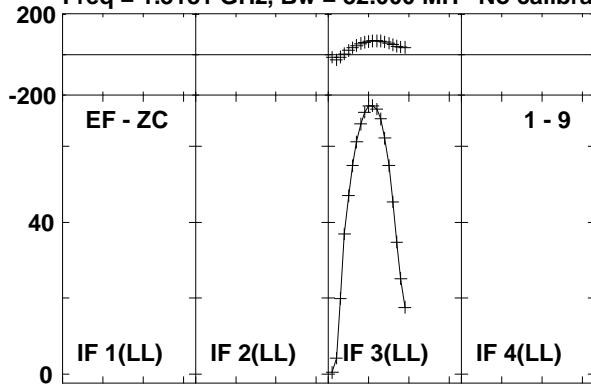

Lower frame: Milli Ampl Jy Top frame: Phas deg
Vector averaged cross-power spectrum Baseline: EF (01) - ZC (09)
Timerange: 00/03:07:03 to 00/03:16:59

Plot file version 15 created 20-NOV-2015 13:43:50

3C84 EO013 1.UVDATA.1

Freq = 1.3181 GHz, Bw = 32.000 MH No calibration applied and no bandpass applied

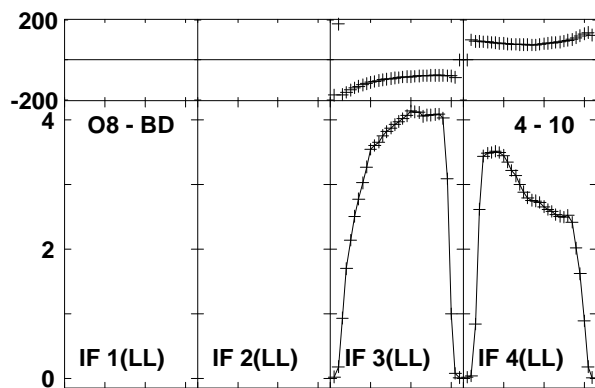
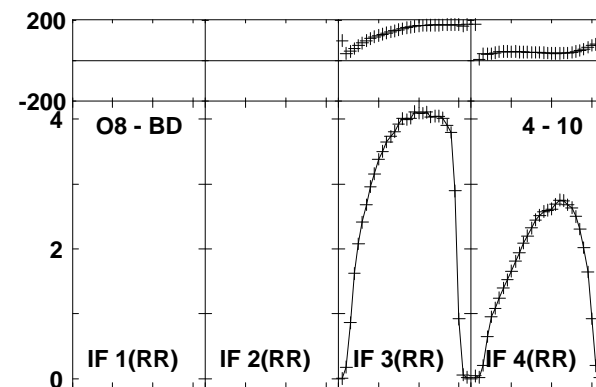
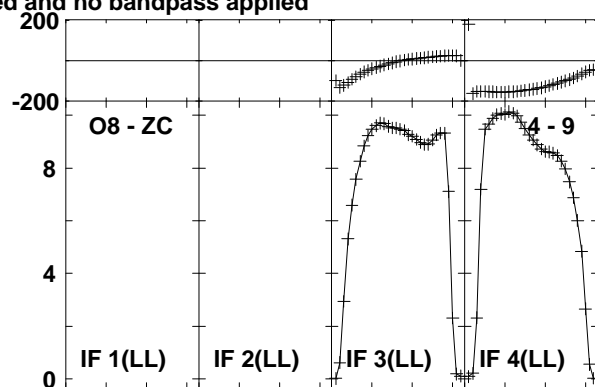
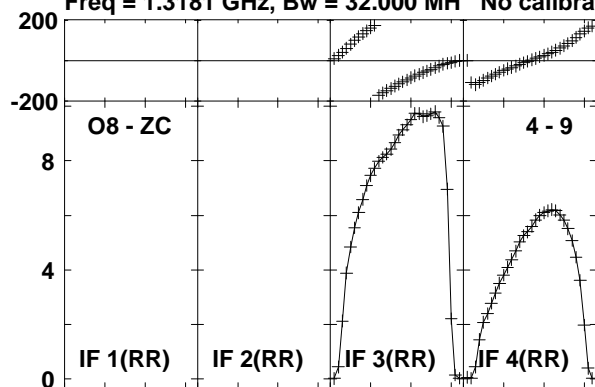

Lower frame: Milli Ampl Jy Top frame: Phas deg
Vector averaged cross-power spectrum Baseline: O8 (04) - ZC (09)
Timerange: 00/03:07:03 to 00/03:16:59

Plot file version 16 created 20-NOV-2015 13:43:50

3C454.3 EO013 1.UVDATA.1

Freq = 1.3181 GHz, Bw = 32.000 MH No calibration applied and no bandpass applied

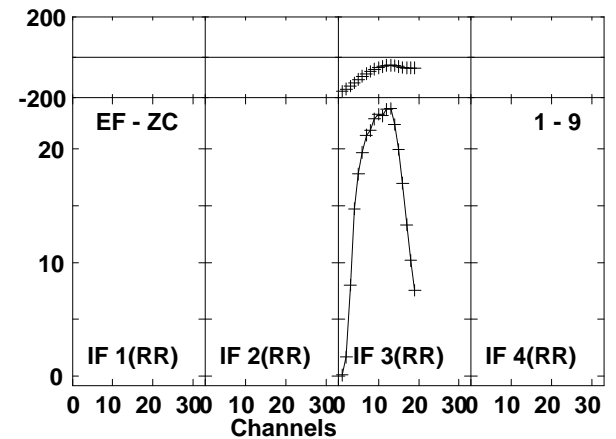
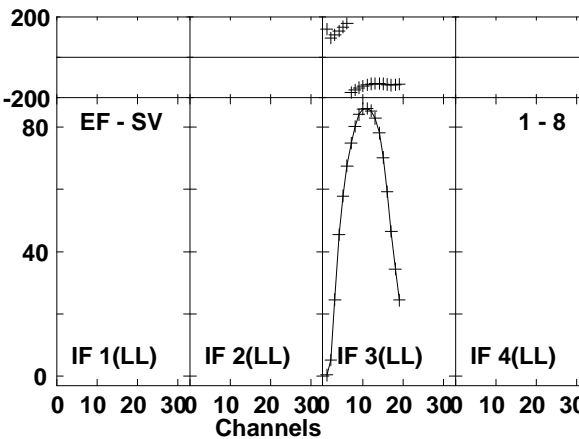
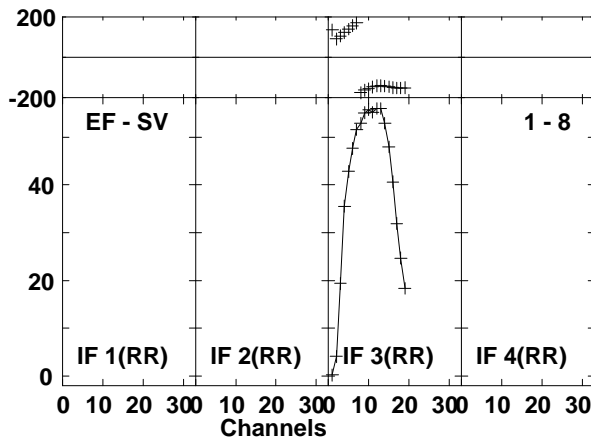
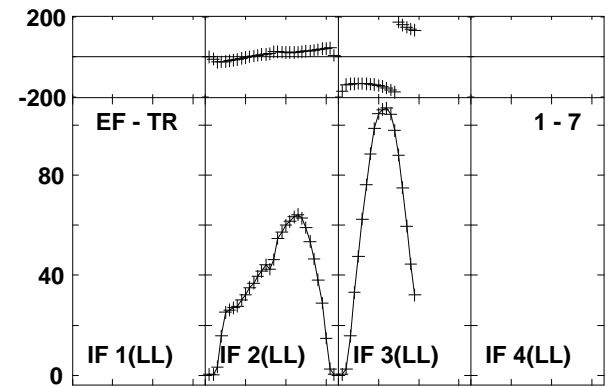
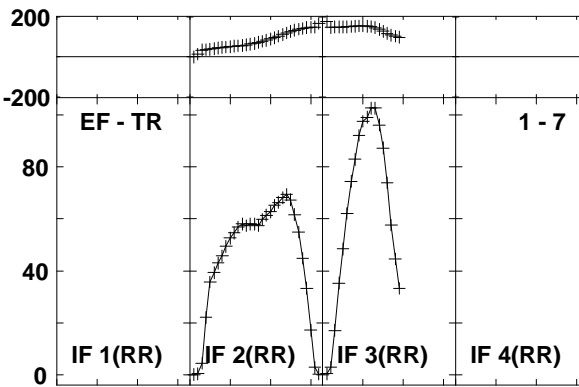
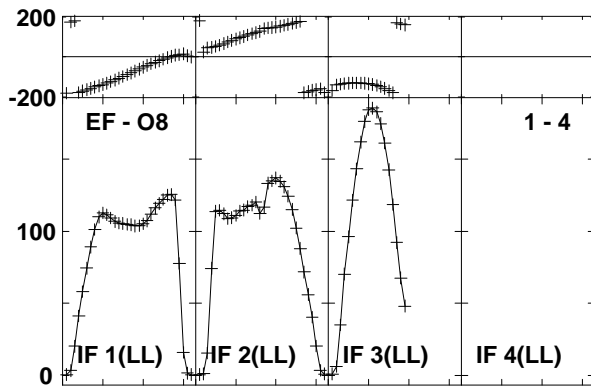
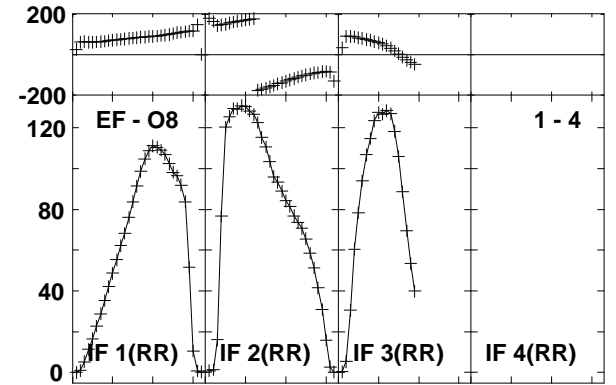
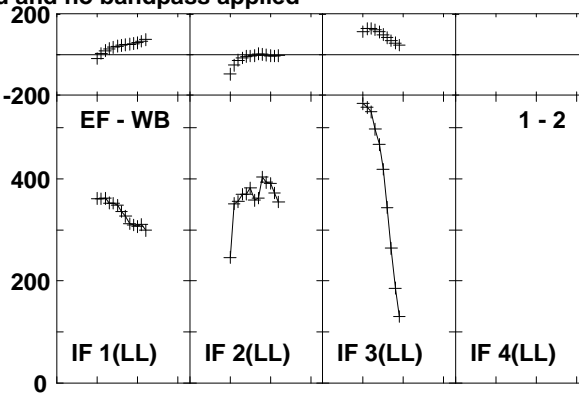
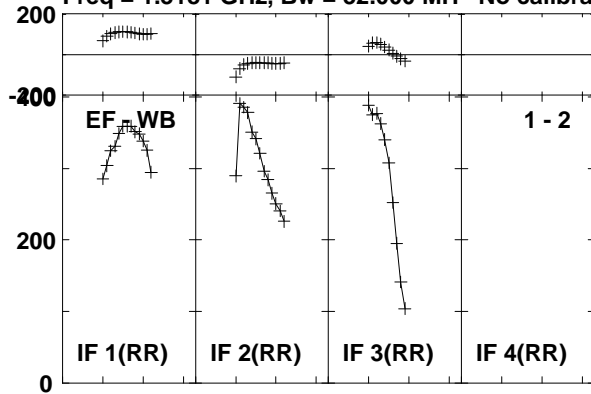

Lower frame: Milli Ampl Jy Top frame: Phas deg
Vector averaged cross-power spectrum Baseline: EF (01) - WB (02)
Timerange: 00/03:22:43 to 00/03:32:39

Plot file version 17 created 20-NOV-2015 13:43:50

3C454.3 EO013 1.UVDATA.1

Freq = 1.3181 GHz, Bw = 32.000 MH No calibration applied and no bandpass applied

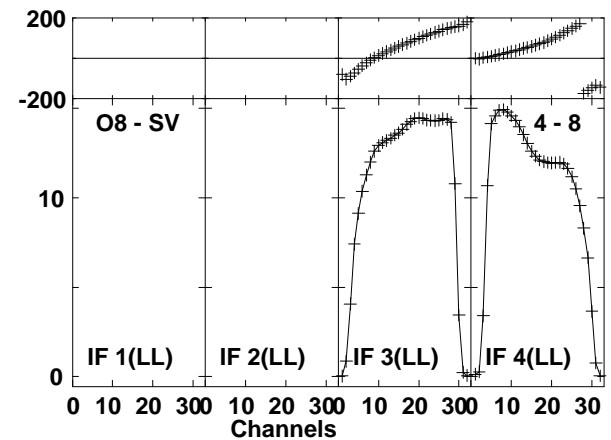
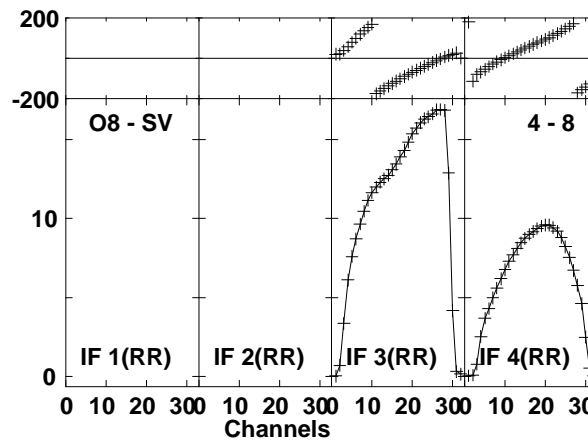
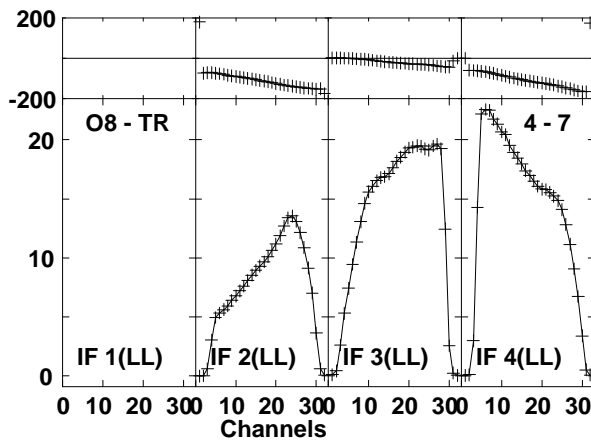
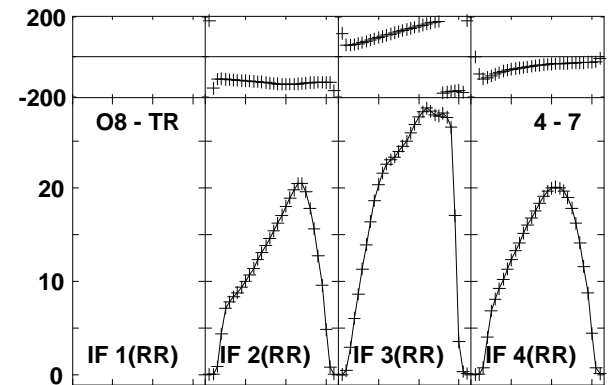
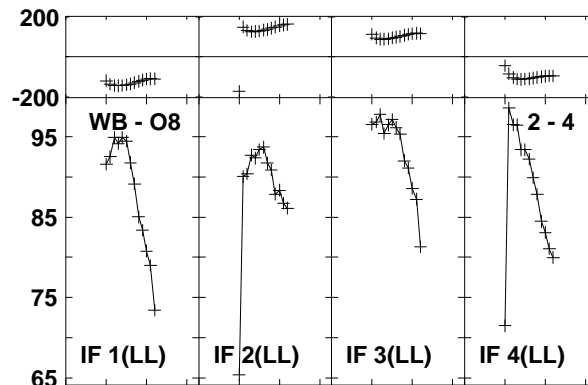
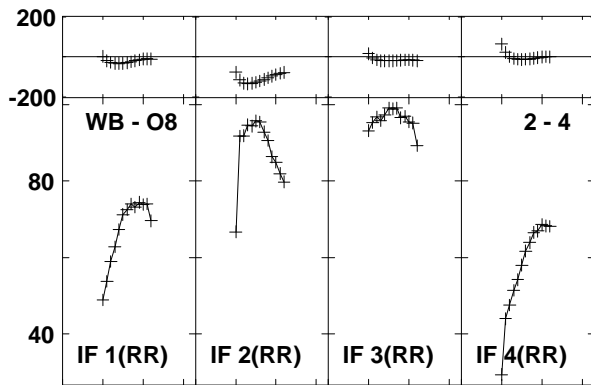
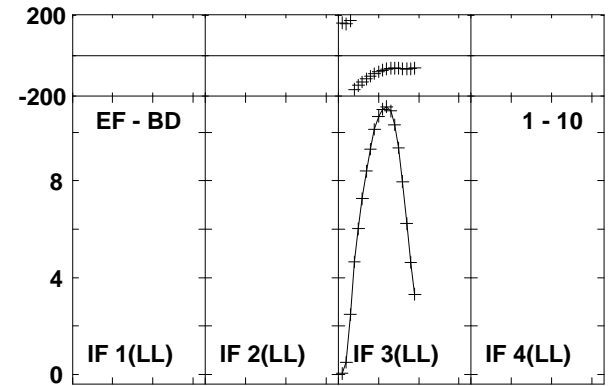
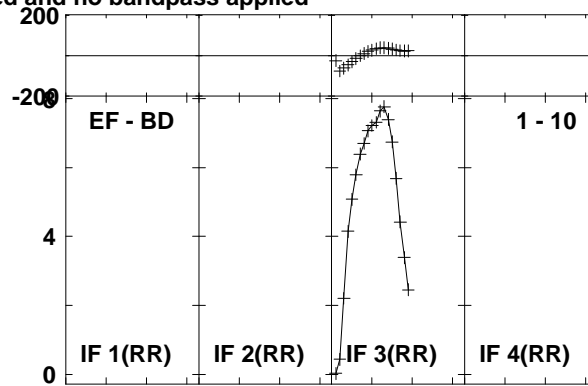
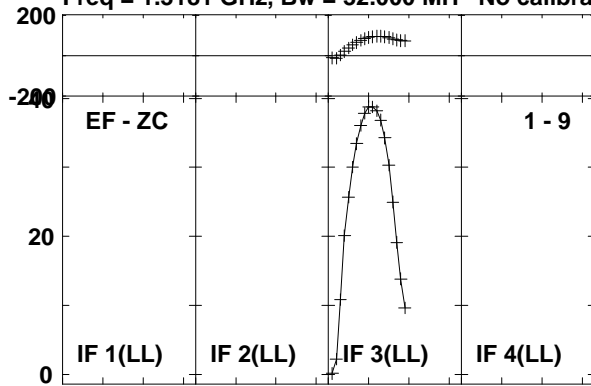

Lower frame: Milli Ampl Jy Top frame: Phas deg
Vector averaged cross-power spectrum Baseline: EF (01) - ZC (09)
Timerange: 00/03:22:43 to 00/03:32:39

Plot file version 18 created 20-NOV-2015 13:43:50
 3C454.3 EO013 1.UVDATA.1
 Freq = 1.3181 GHz, Bw = 32.000 MH No calibration applied and no bandpass applied

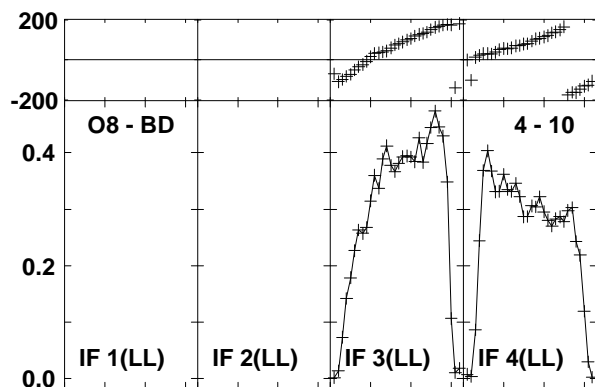
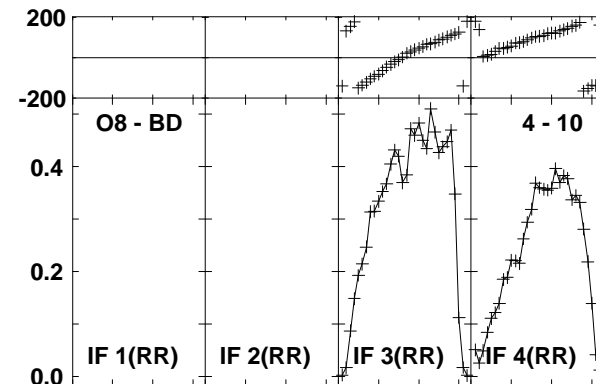
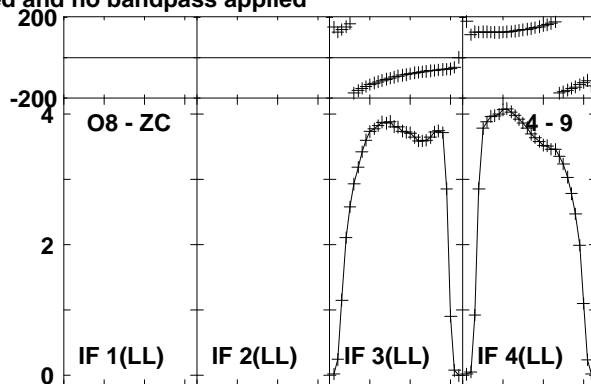
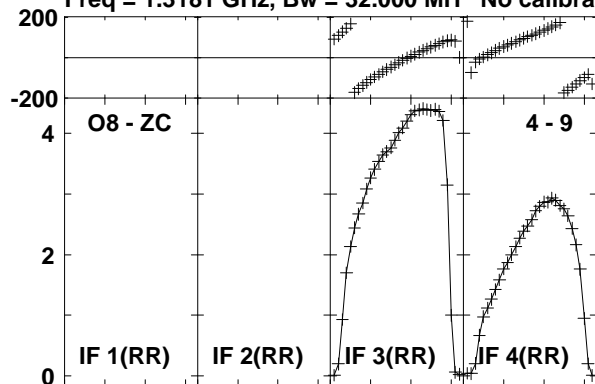

Lower frame: Milli Ampl Jy Top frame: Phas deg
 Vector averaged cross-power spectrum Baseline: O8 (04) - ZC (09)
 Timerange: 00/03:22:43 to 00/03:32:39

Plot file version 19 created 20-NOV-2015 13:43:50

3C454.3 EO013 1.UVDATA.1

Freq = 1.3181 GHz, Bw = 32.000 MH No calibration applied and no bandpass applied

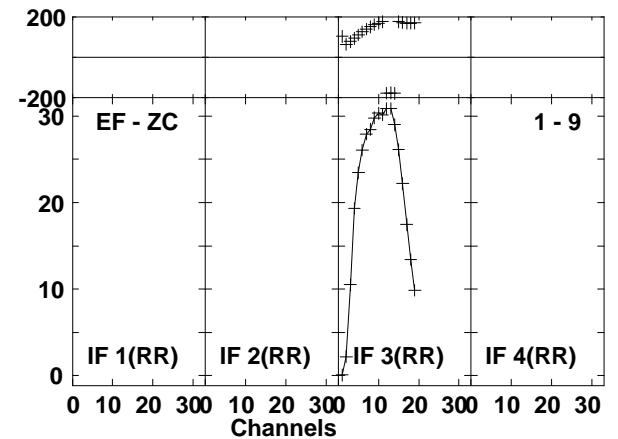
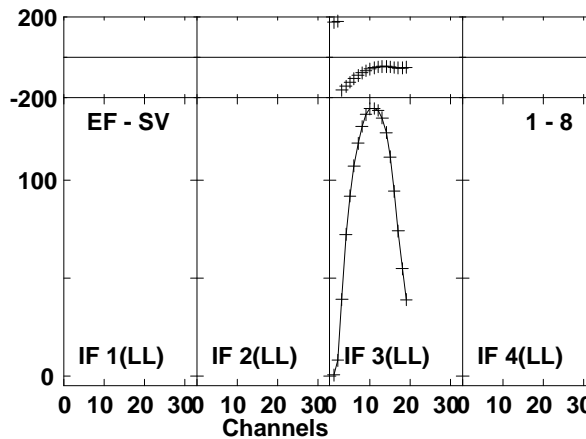
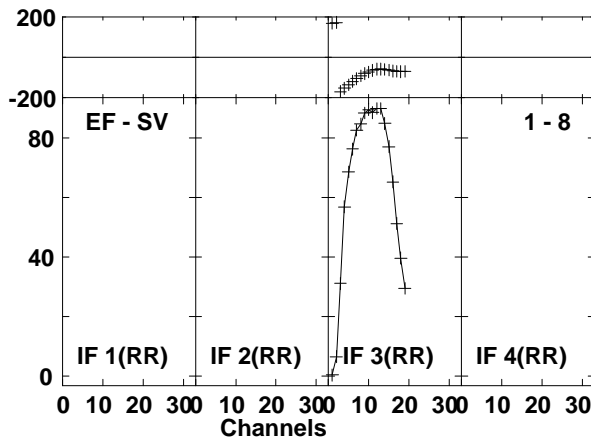
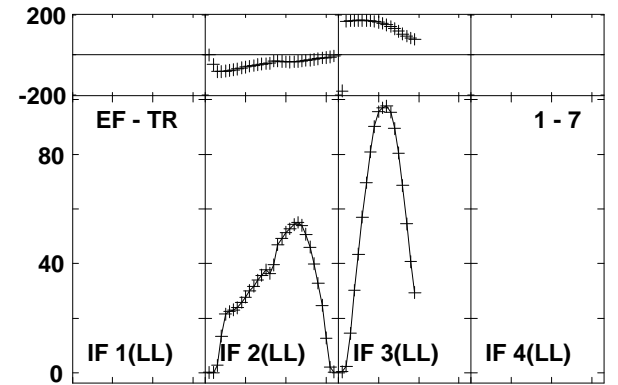
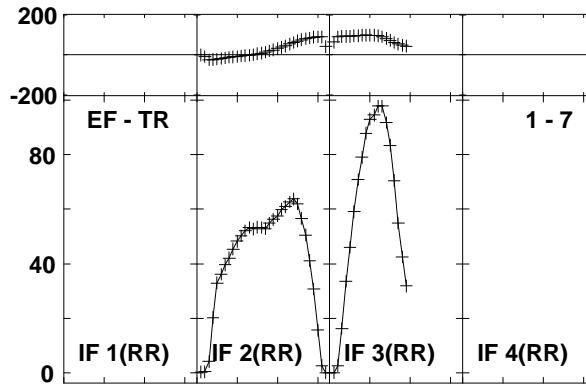
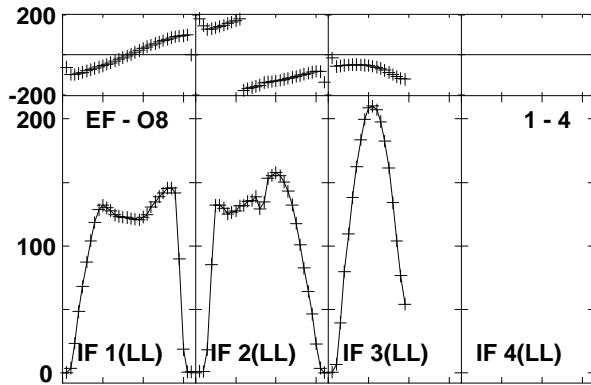
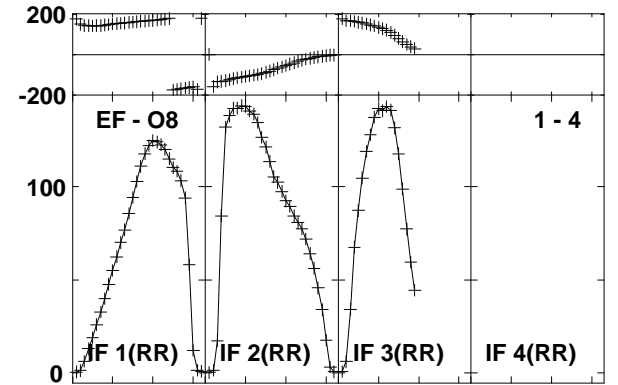
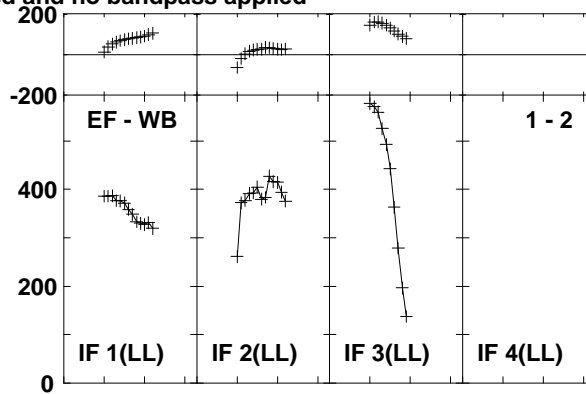
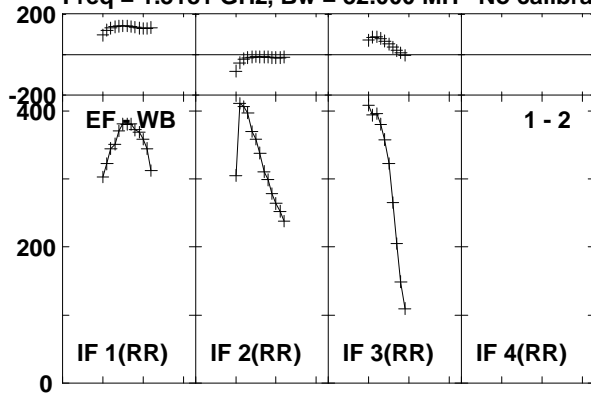

Lower frame: Milli Ampl Jy Top frame: Phas deg
Vector averaged cross-power spectrum Baseline: EF (01) - WB (02)
Timerange: 00/03:33:13 to 00/03:38:09

Plot file version 20 created 20-NOV-2015 13:43:50

3C454.3 EO013 1.UVDATA.1

Freq = 1.3181 GHz, Bw = 32.000 MH No calibration applied and no bandpass applied

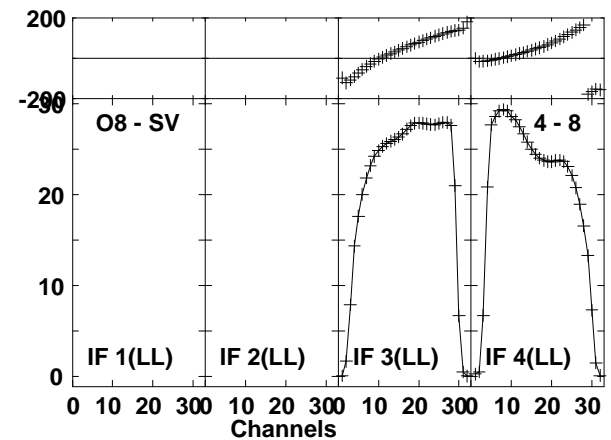
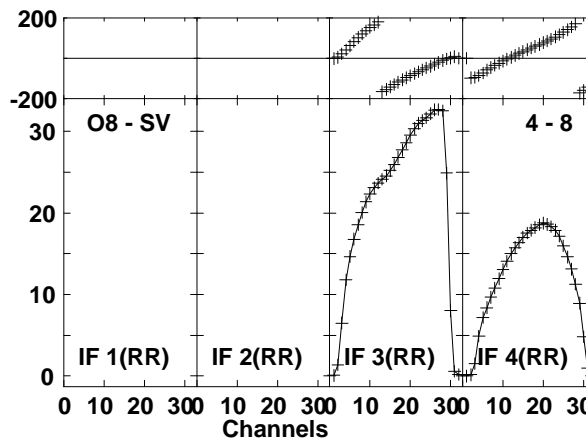
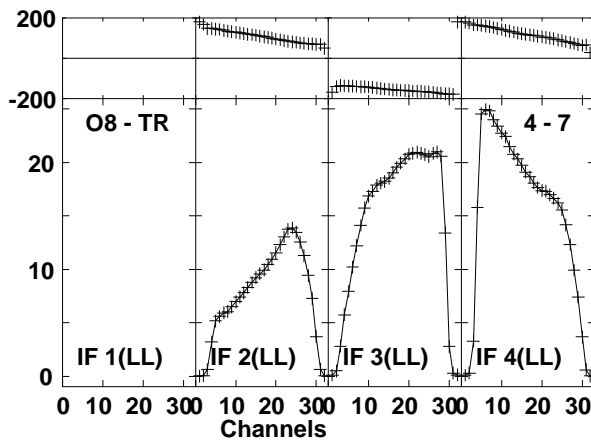
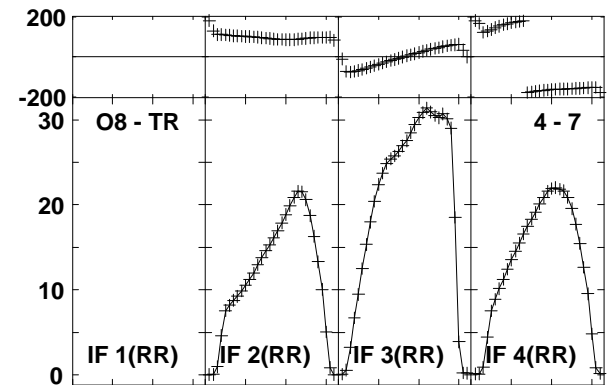
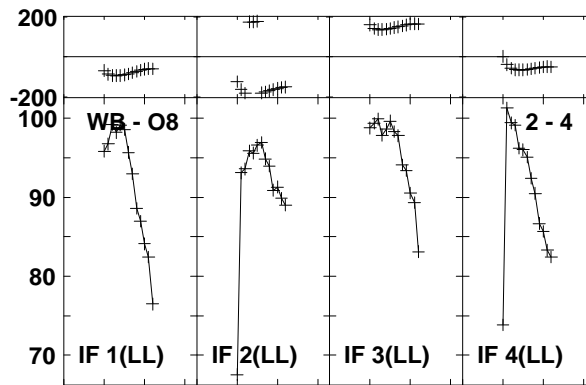
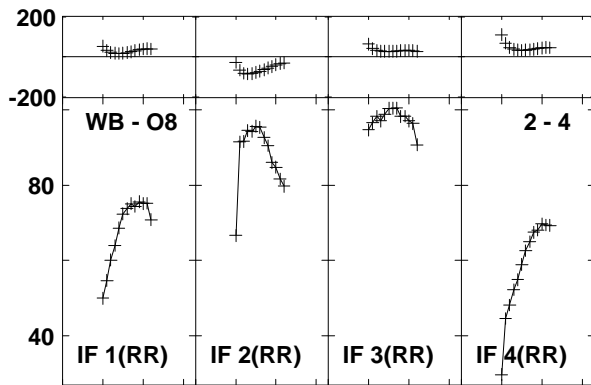
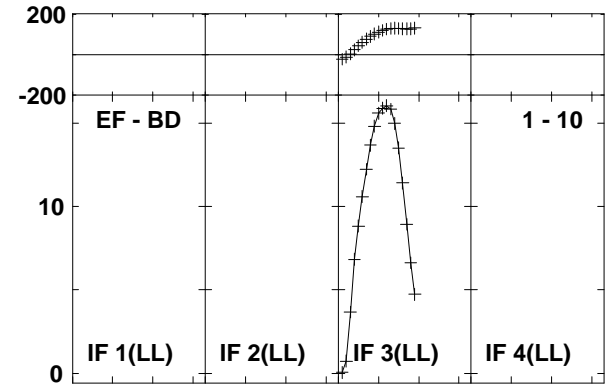
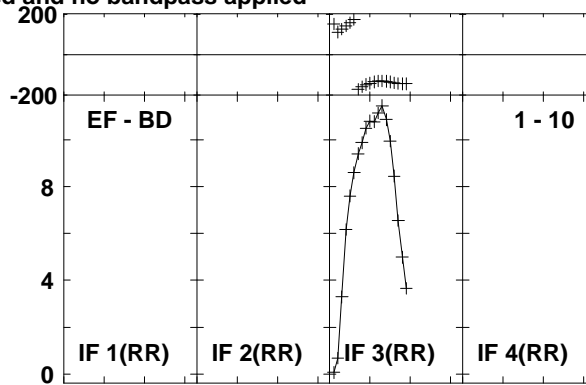
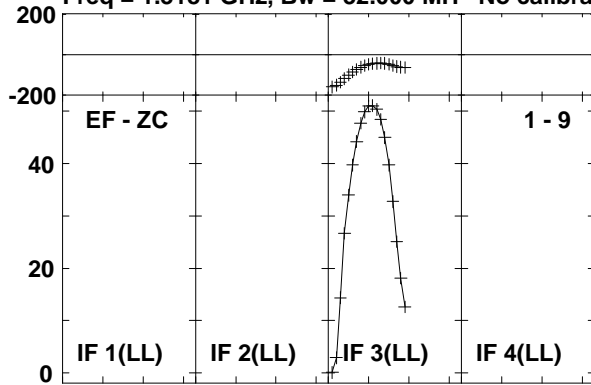

Lower frame: Milli Ampl Jy Top frame: Phas deg
Vector averaged cross-power spectrum Baseline: EF (01) - ZC (09)
Timerange: 00/03:33:13 to 00/03:38:09

Plot file version 21 created 20-NOV-2015 13:43:50

3C454.3 EO013 1.UVDATA.1

Freq = 1.3181 GHz, Bw = 32.000 MH No calibration applied and no bandpass applied

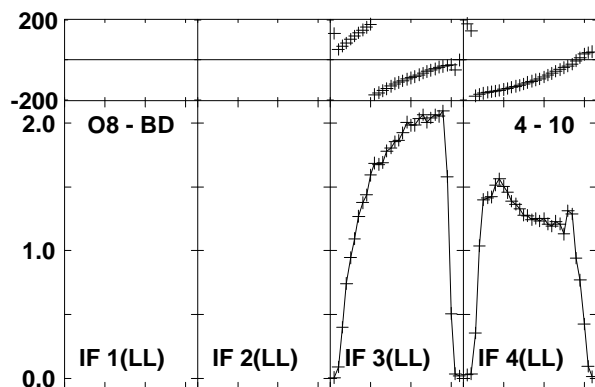
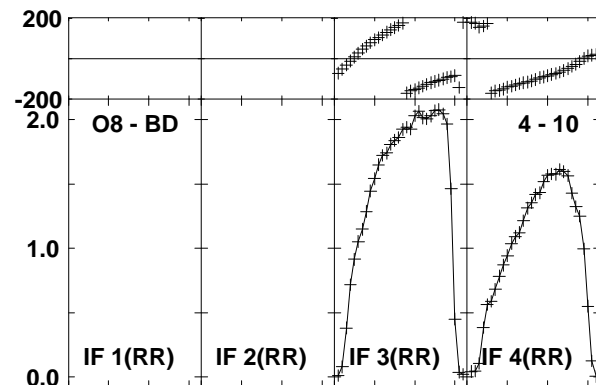
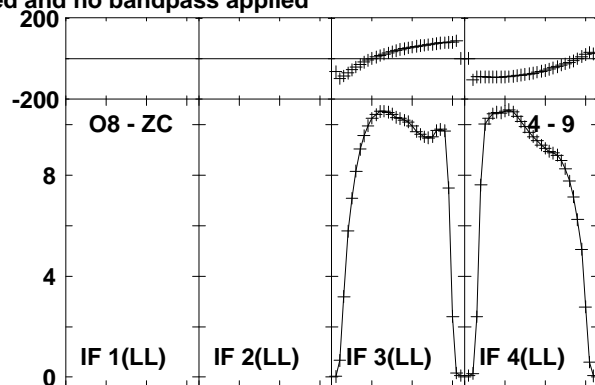
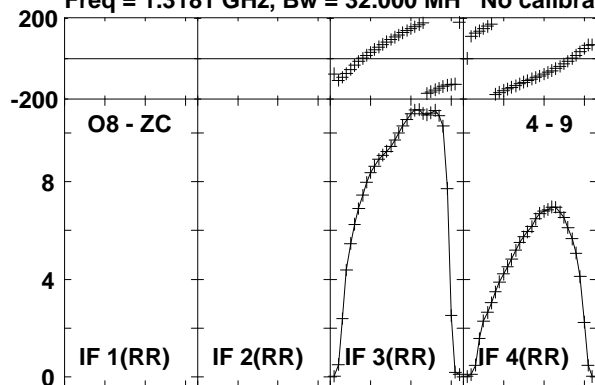

Lower frame: Milli Ampl Jy Top frame: Phas deg
Vector averaged cross-power spectrum Baseline: O8 (04) - ZC (09)
Timerange: 00/03:33:13 to 00/03:38:09

Plot file version 22 created 20-NOV-2015 13:43:50

3C84 EO013 1.UVDATA.1

Freq = 1.3181 GHz, Bw = 32.000 MH No calibration applied and no bandpass applied

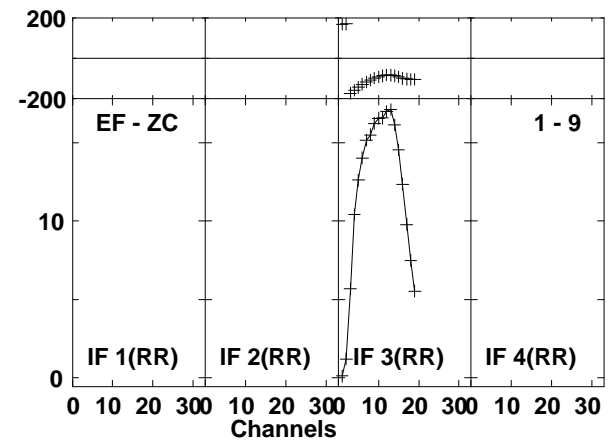
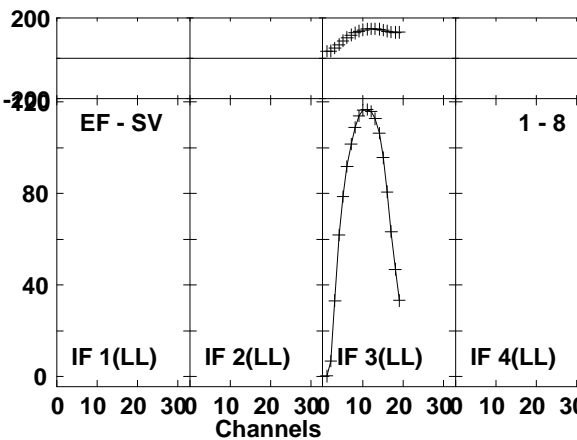
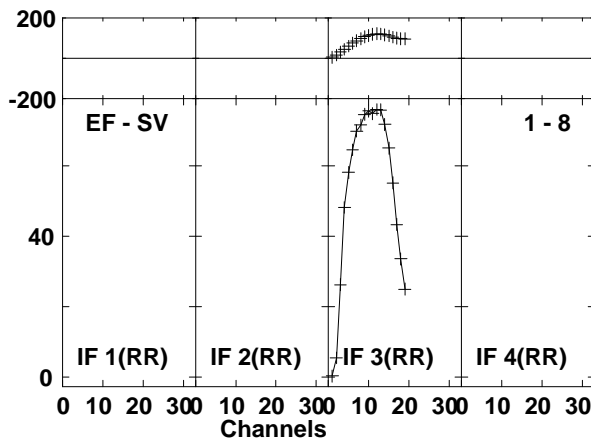
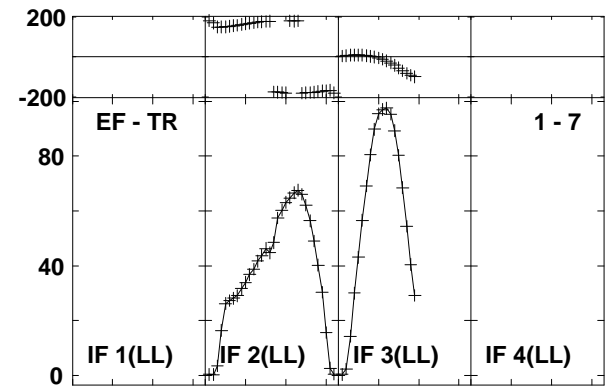
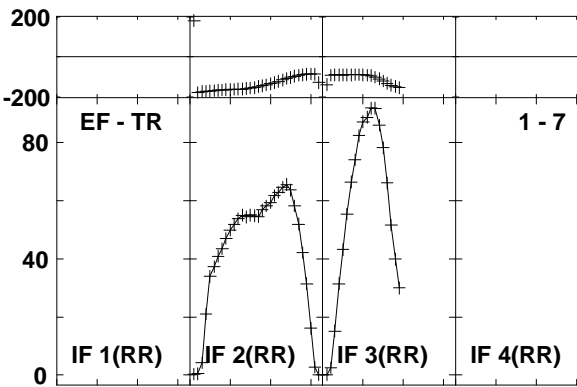
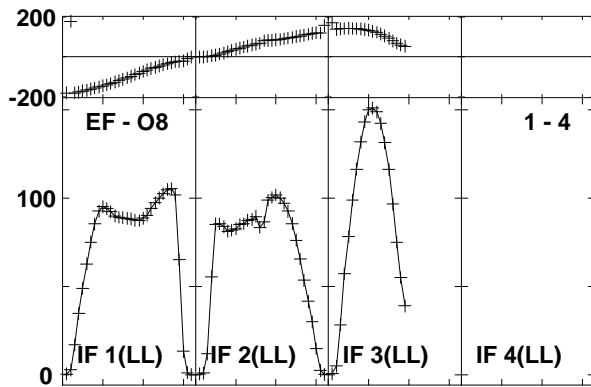
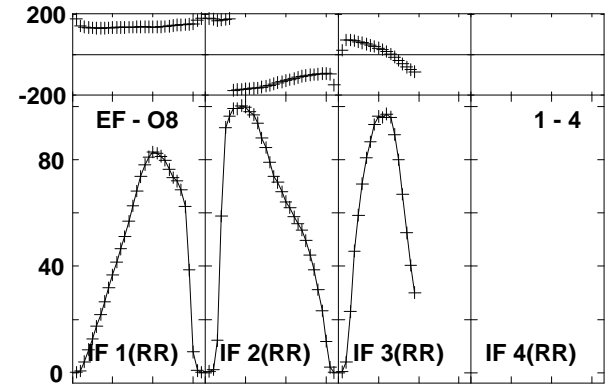
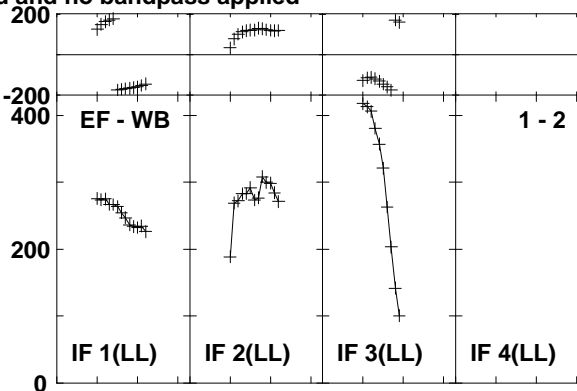
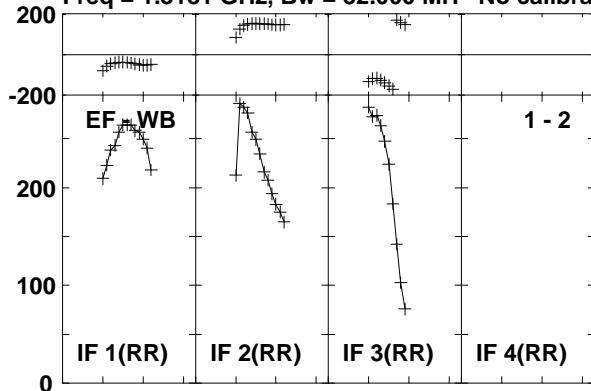

Lower frame: Milli Ampl Jy Top frame: Phas deg
Vector averaged cross-power spectrum Baseline: EF (01) - WB (02)
Timerange: 00/03:43:53 to 00/03:53:49

Plot file version 23 created 20-NOV-2015 13:43:50
 3C84 EO013 1.UVDATA.1
 Freq = 1.3181 GHz, Bw = 32.000 MH No calibration applied and no bandpass applied

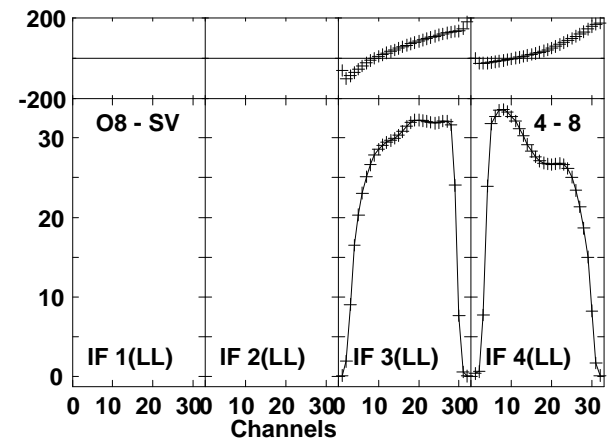
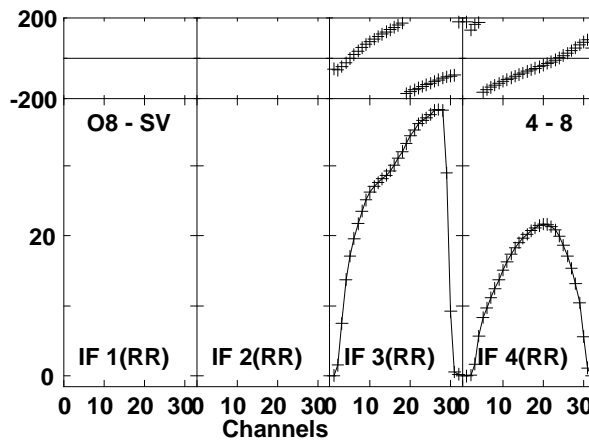
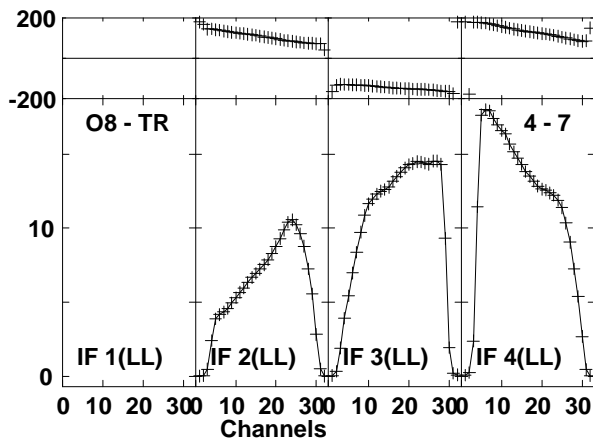
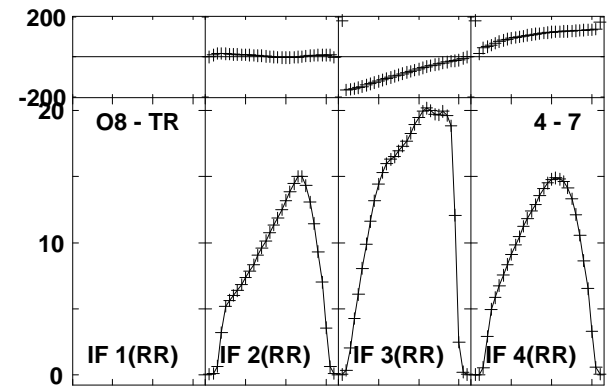
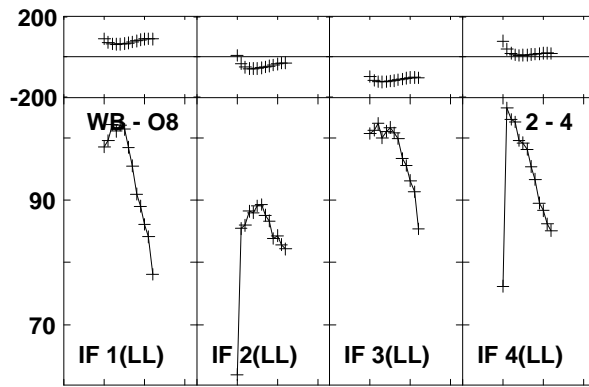
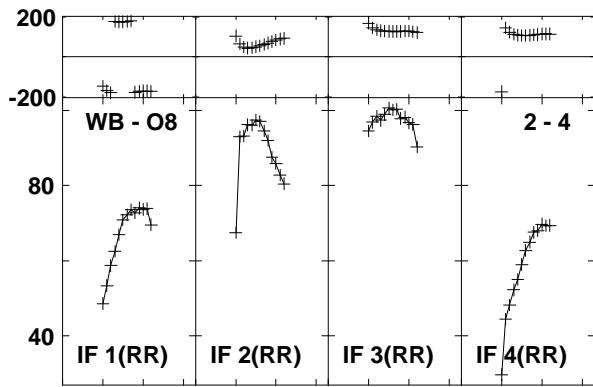
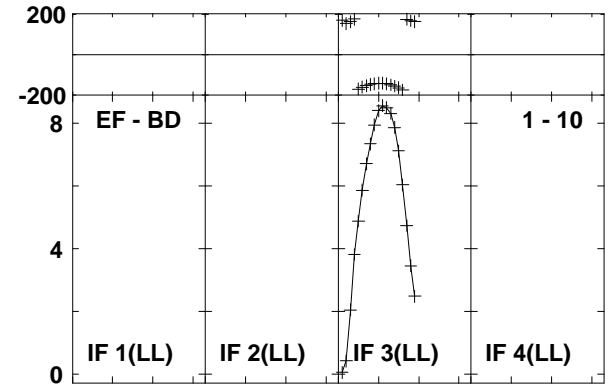
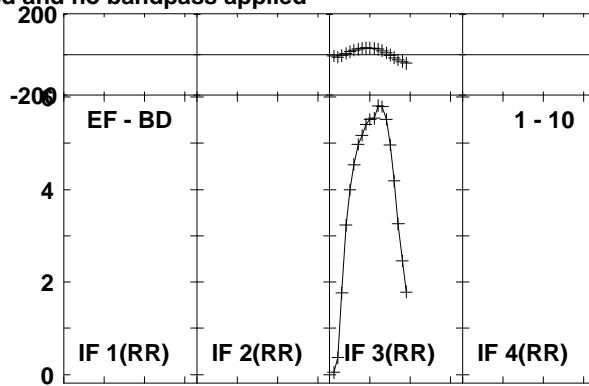
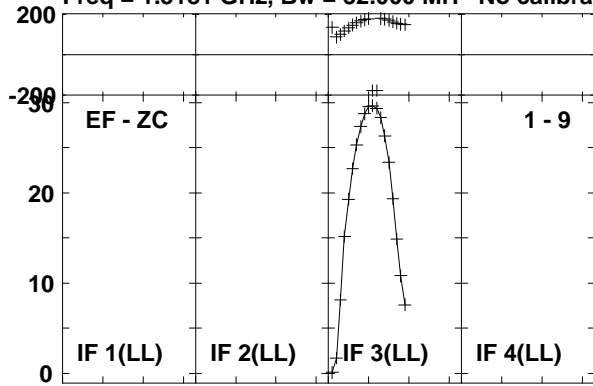

Lower frame: Milli Ampl Jy Top frame: Phas deg
 Vector averaged cross-power spectrum Baseline: EF (01) - ZC (09)
 Timerange: 00/03:43:53 to 00/03:53:49

Plot file version 24 created 20-NOV-2015 13:43:50
 3C84 EO013 1.UVDATA.1
 Freq = 1.3181 GHz, Bw = 32.000 MH No calibration applied and no bandpass applied

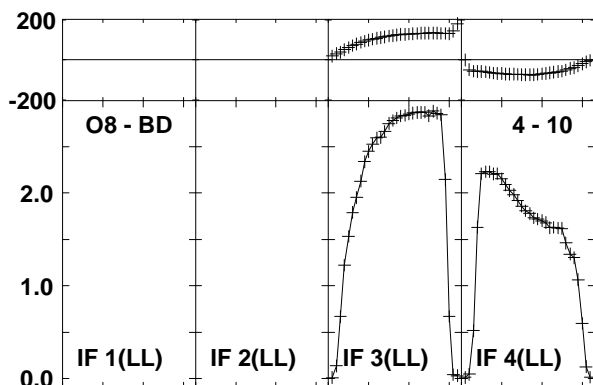
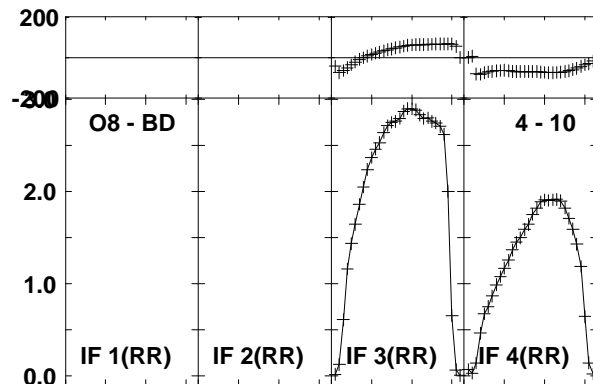
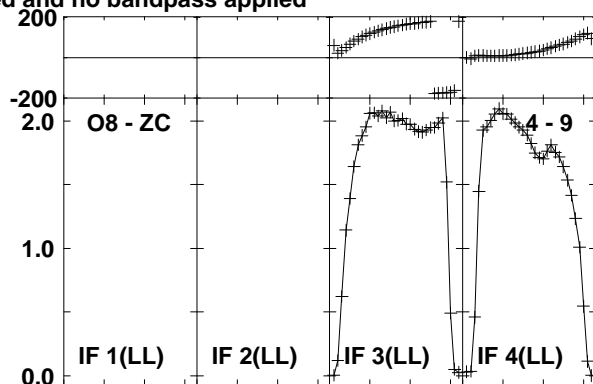
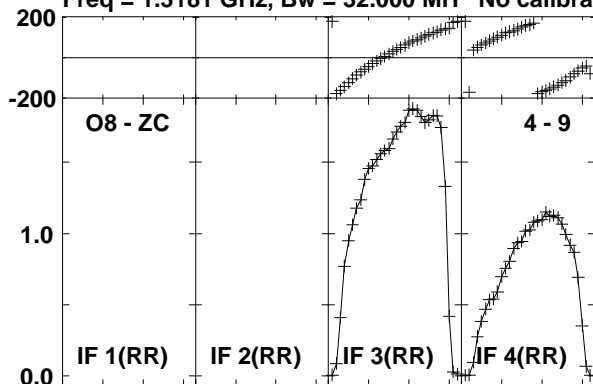

Lower frame: Milli Ampl Jy Top frame: Phas deg
 Vector averaged cross-power spectrum Baseline: O8 (04) - ZC (09)
 Timerange: 00/03:43:53 to 00/03:53:49

Plot file version 25 created 20-NOV-2015 13:43:50

3C84 EO013 1.UVDATA.1

Freq = 1.3181 GHz, Bw = 32.000 MH No calibration applied and no bandpass applied

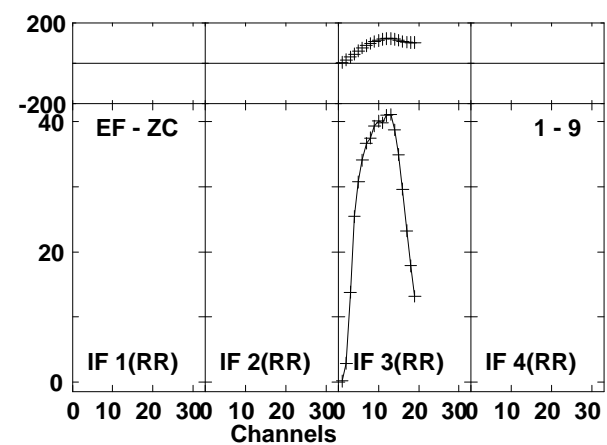
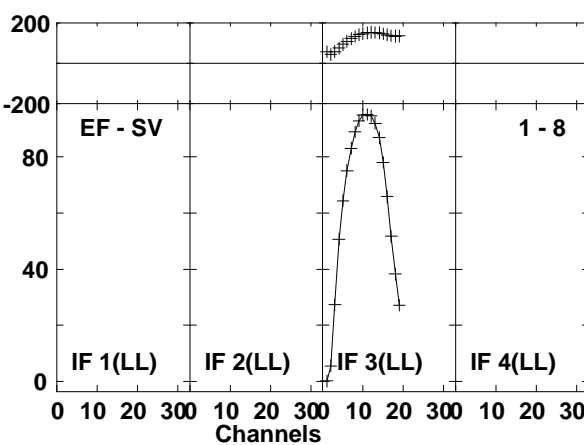
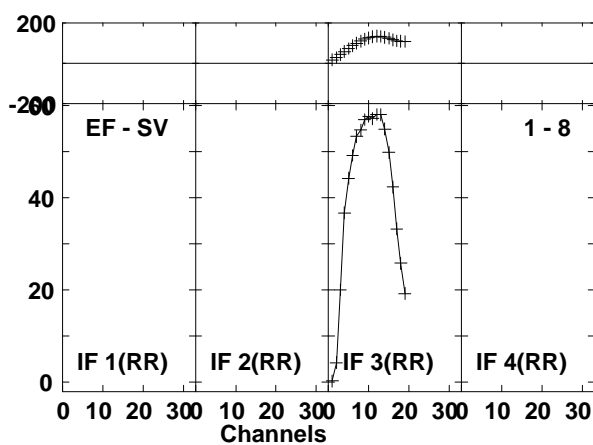
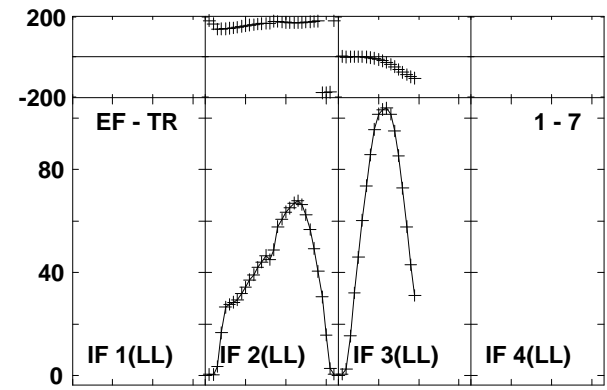
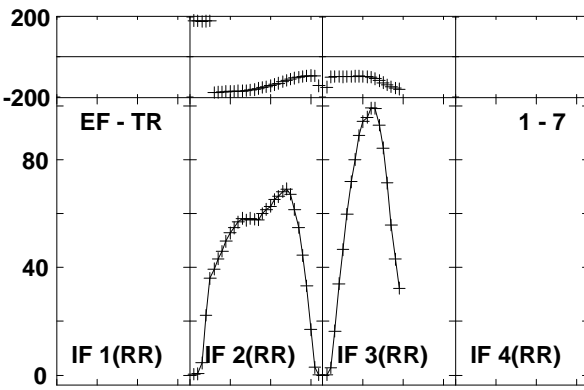
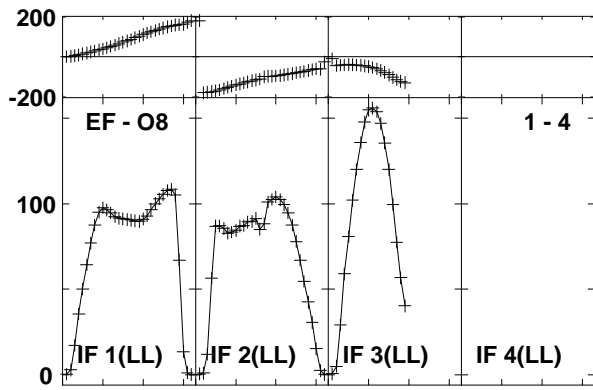
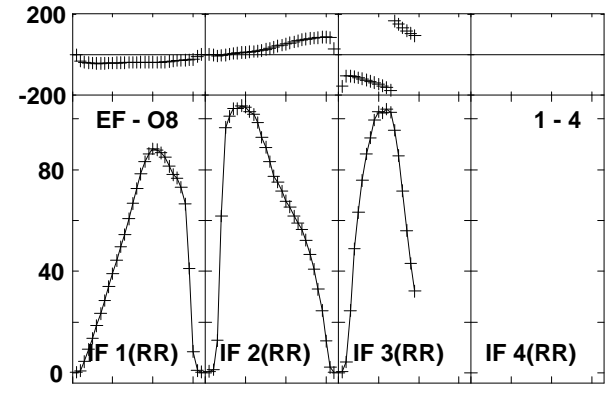
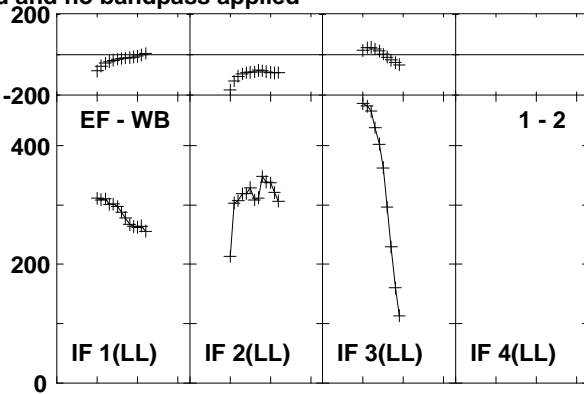
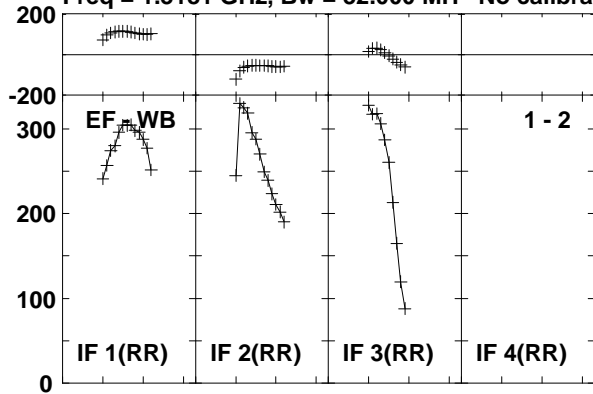

Lower frame: Milli Ampl Jy Top frame: Phas deg
Vector averaged cross-power spectrum Baseline: EF (01) - WB (02)
Timerange: 00/03:54:23 to 00/04:04:19

Plot file version 26 created 20-NOV-2015 13:43:51
 3C84 EO013 1.UVDATA.1
 Freq = 1.3181 GHz, Bw = 32.000 MH No calibration applied and no bandpass applied

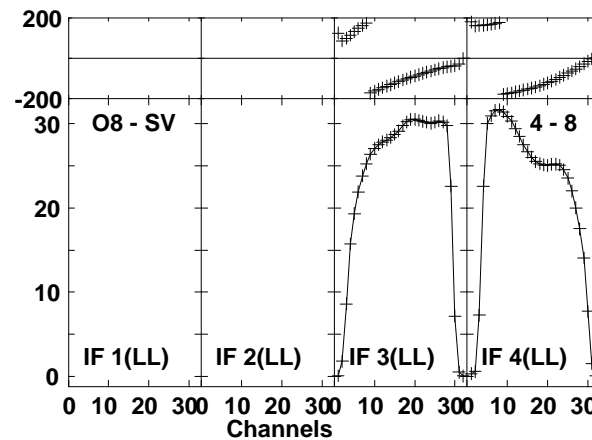
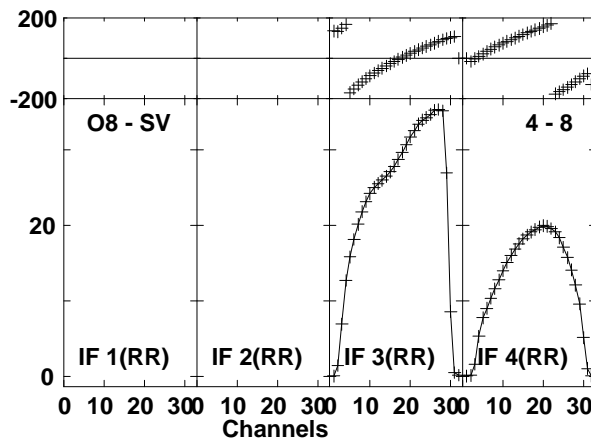
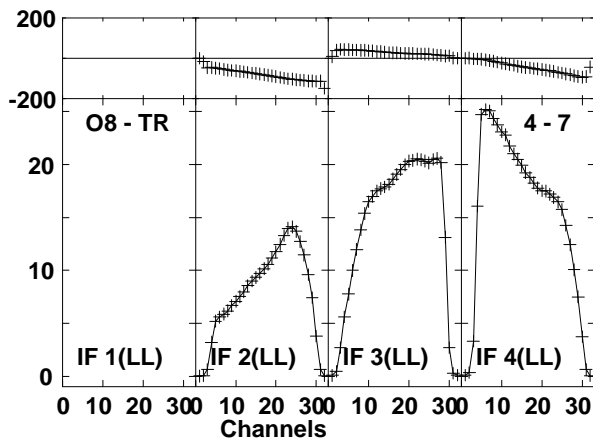
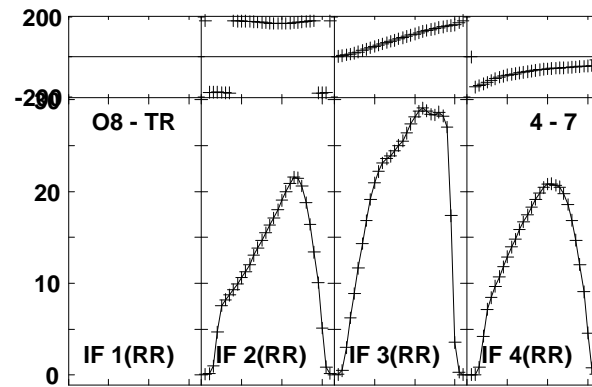
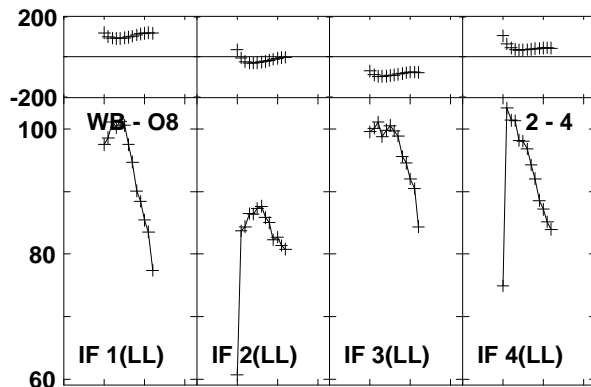
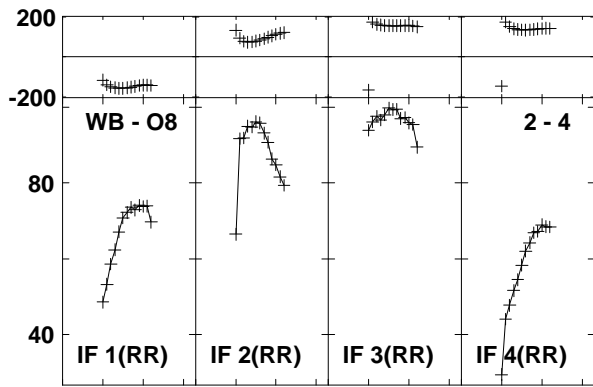
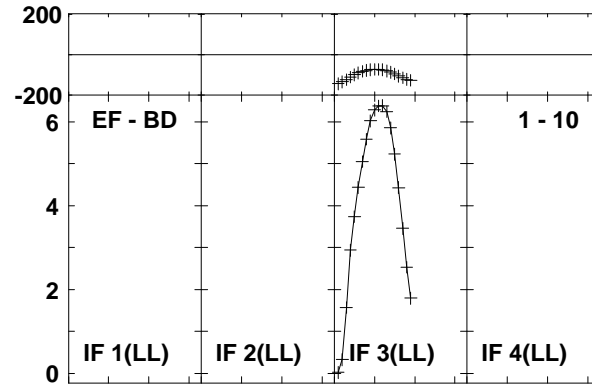
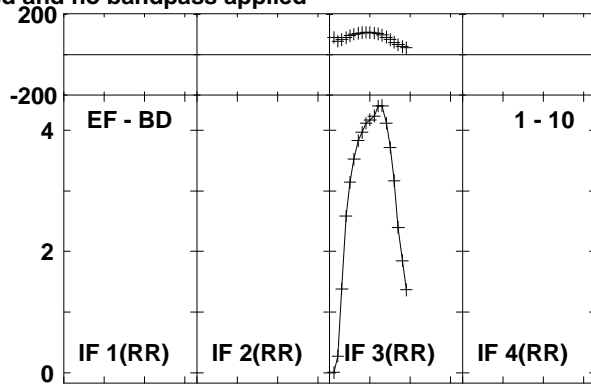
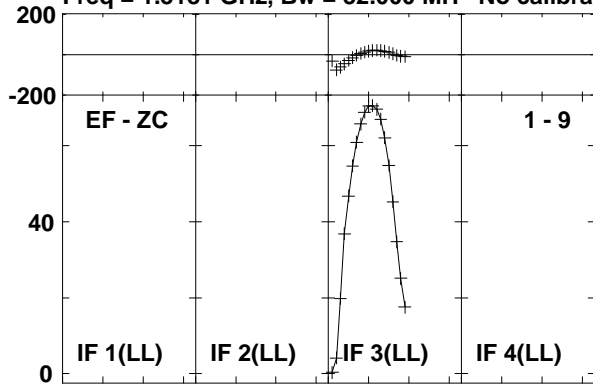

Lower frame: Milli Ampl Jy Top frame: Phas deg
 Vector averaged cross-power spectrum Baseline: EF (01) - ZC (09)
 Timerange: 00/03:54:23 to 00/04:04:19

Plot file version 27 created 20-NOV-2015 13:43:51
 3C84 EO013 1.UVDATA.1
 Freq = 1.3181 GHz, Bw = 32.000 MH No calibration applied and no bandpass applied

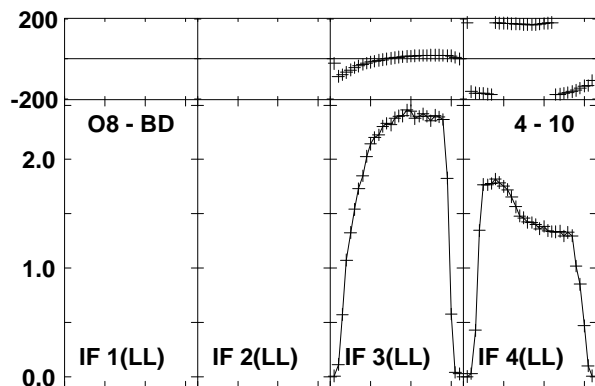
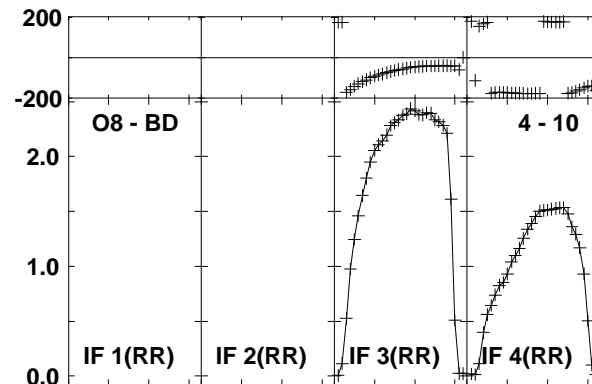
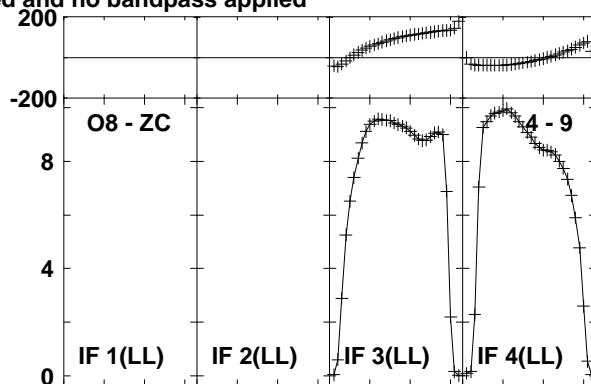
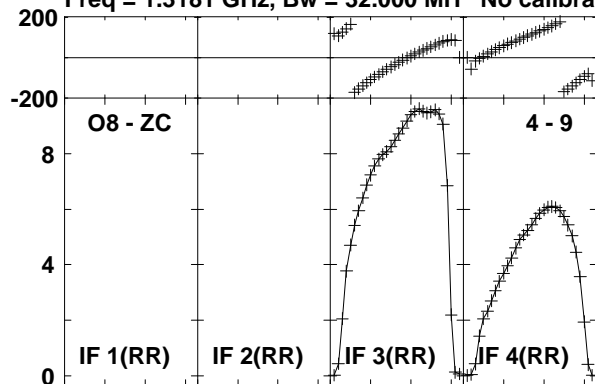

Lower frame: Milli Ampl Jy Top frame: Phas deg
 Vector averaged cross-power spectrum Baseline: O8 (04) - ZC (09)
 Timerange: 00/03:54:23 to 00/04:04:19

Plot file version 28 created 20-NOV-2015 13:43:51
 3C84 EO013 1.UVDATA.1
 Freq = 1.3181 GHz, Bw = 32.000 MH No calibration applied and no bandpass applied

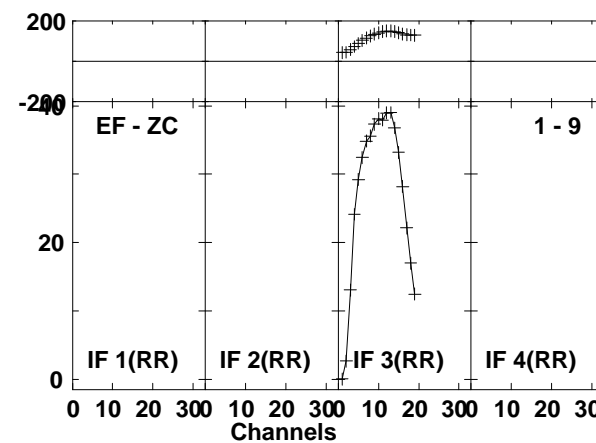
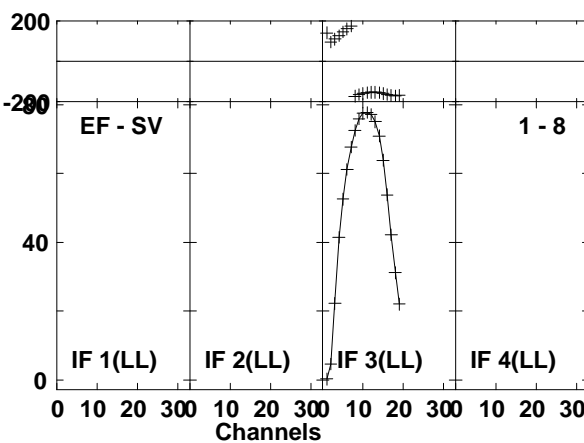
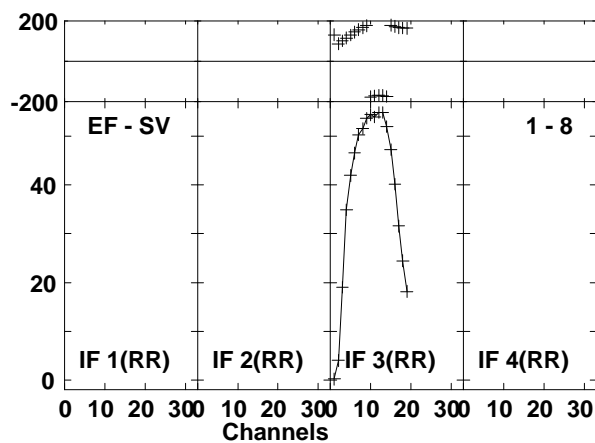
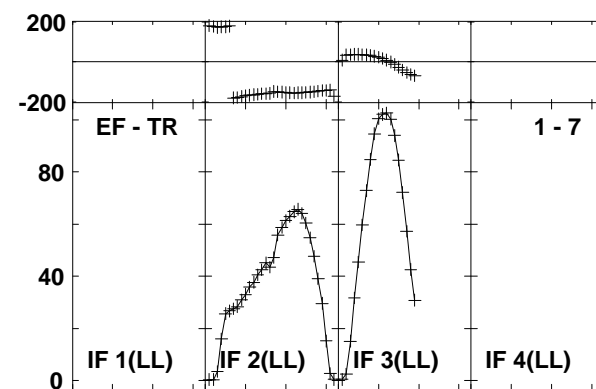
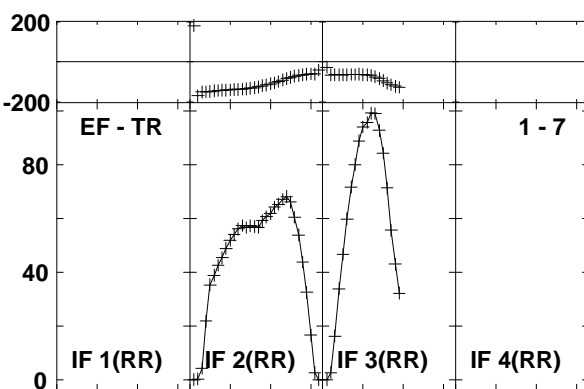
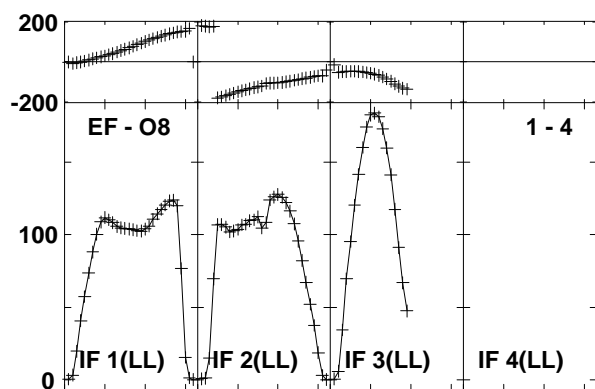
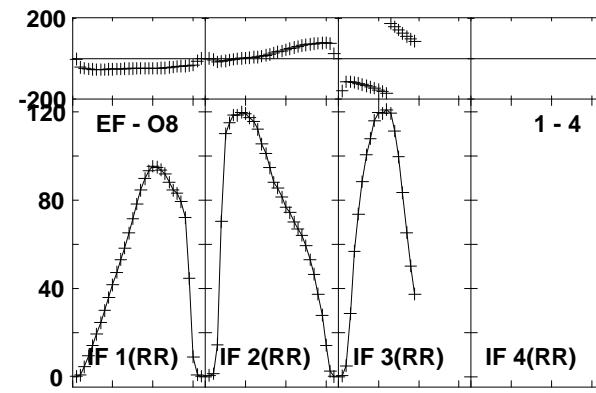
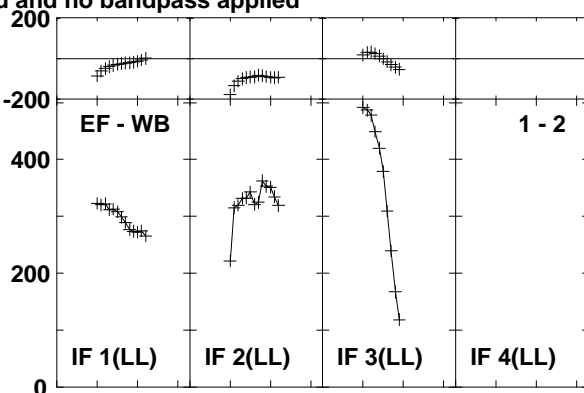
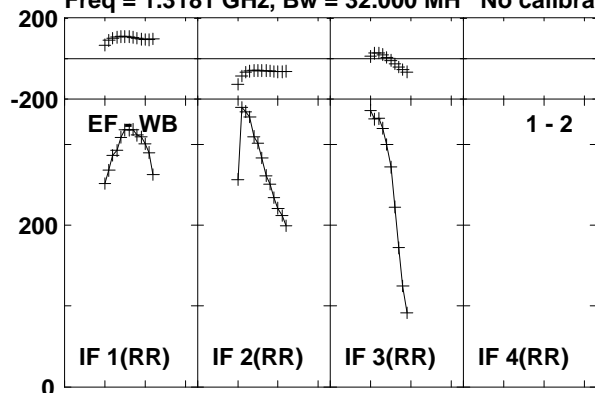

Lower frame: Milli Ampl Jy Top frame: Phas deg
 Vector averaged cross-power spectrum Baseline: EF (01) - WB (02)
 Timerange: 00/04:04:53 to 00/04:14:49

Plot file version 29 created 20-NOV-2015 13:43:51

3C84 EO013 1.UVDATA.1

Freq = 1.3181 GHz, Bw = 32.000 MH No calibration applied and no bandpass applied

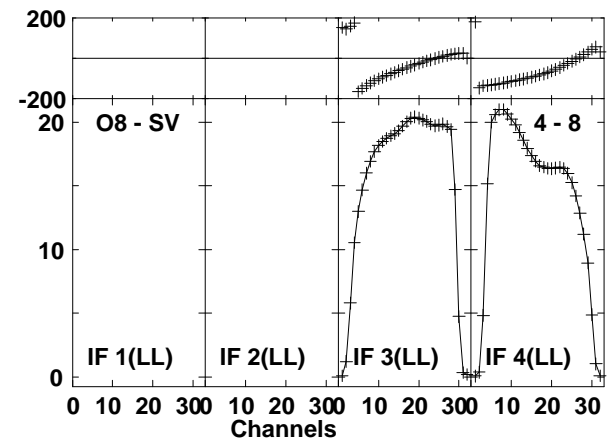
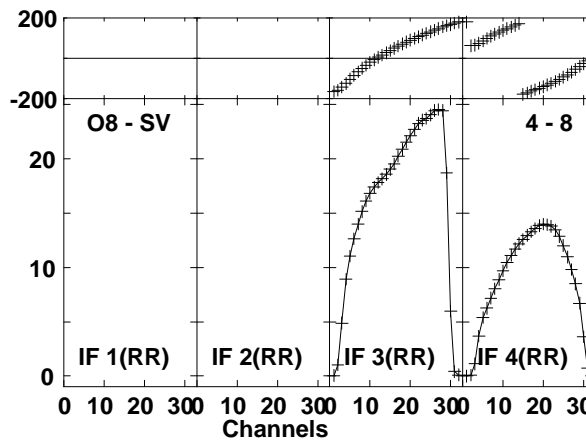
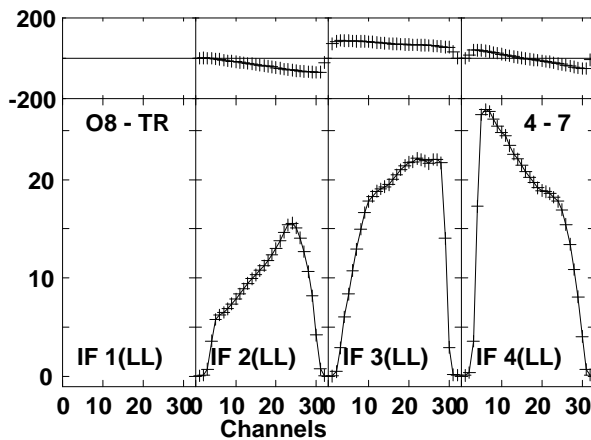
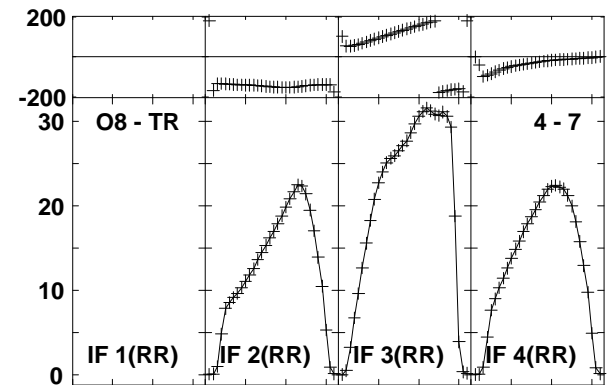
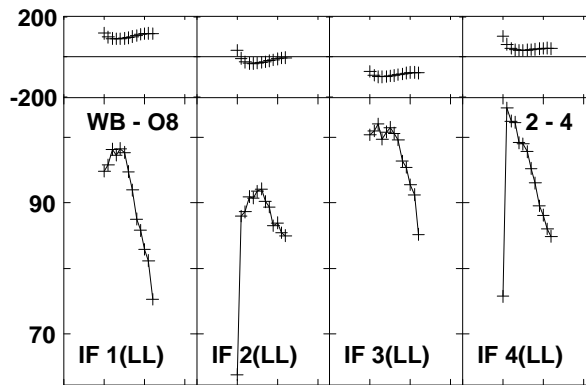
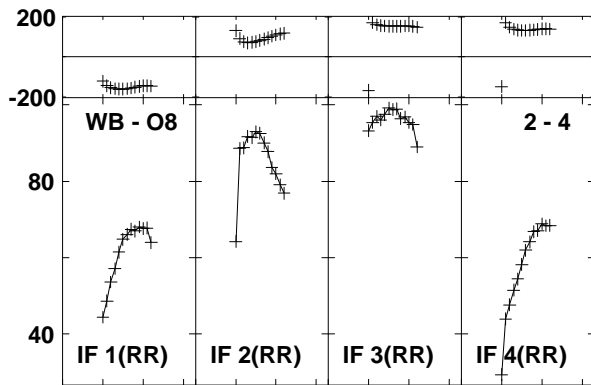
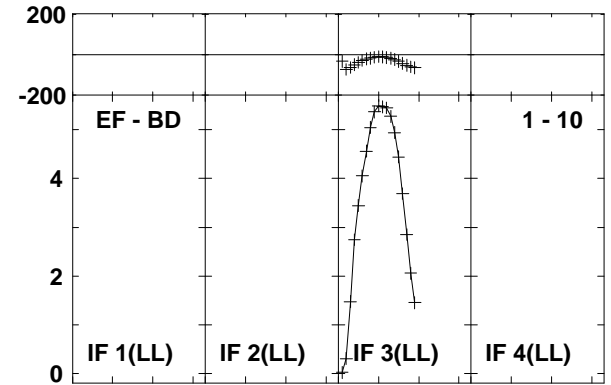
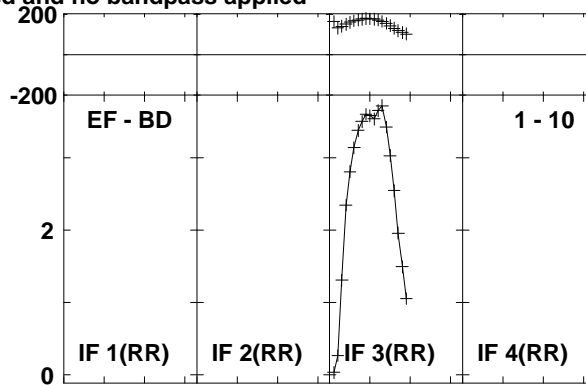
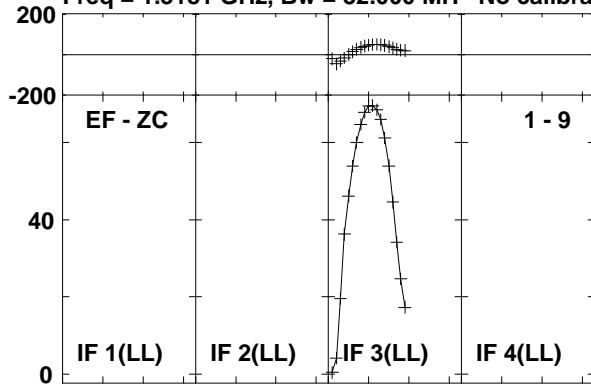

Lower frame: Milli Ampl Jy Top frame: Phas deg
Vector averaged cross-power spectrum Baseline: EF (01) - ZC (09)
Timerange: 00/04:04:53 to 00/04:14:49

Plot file version 30 created 20-NOV-2015 13:43:51
 3C84 EO013 1.UVDATA.1
 Freq = 1.3181 GHz, Bw = 32.000 MH No calibration applied and no bandpass applied

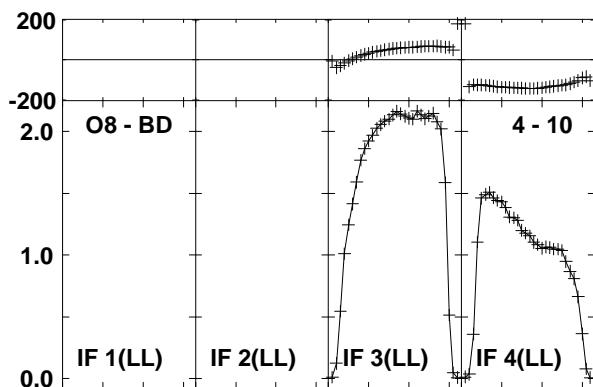
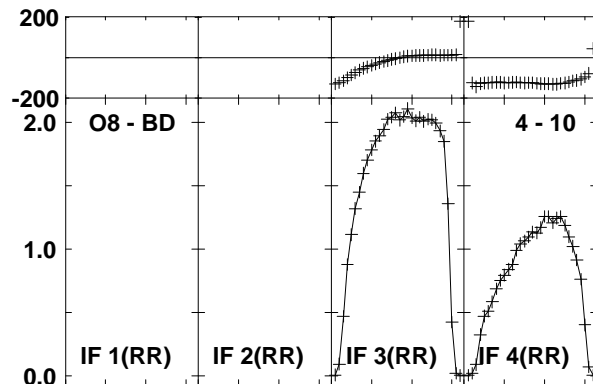
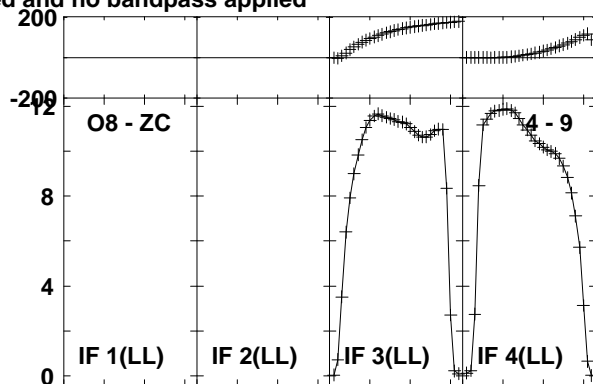
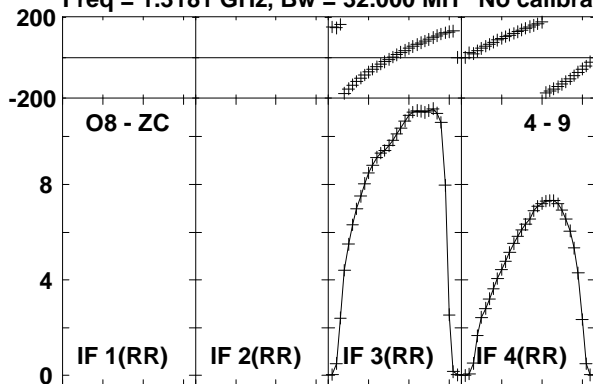

Lower frame: Milli Ampl Jy Top frame: Phas deg
 Vector averaged cross-power spectrum Baseline: O8 (04) - ZC (09)
 Timerange: 00/04:04:53 to 00/04:14:49

Plot file version 31 created 20-NOV-2015 13:43:51

3C454.3 EO013 1.UVDATA.1

Freq = 1.3181 GHz, Bw = 32.000 MH No calibration applied and no bandpass applied

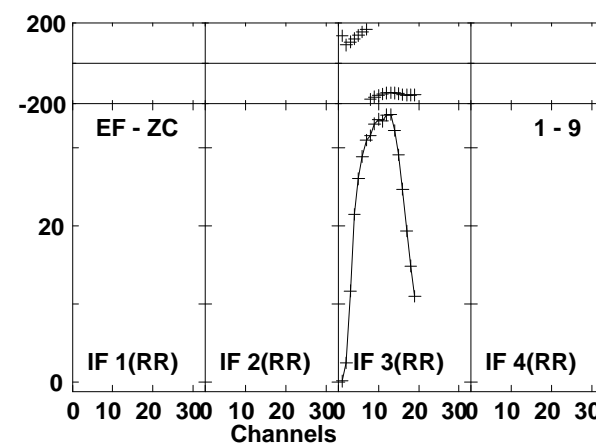
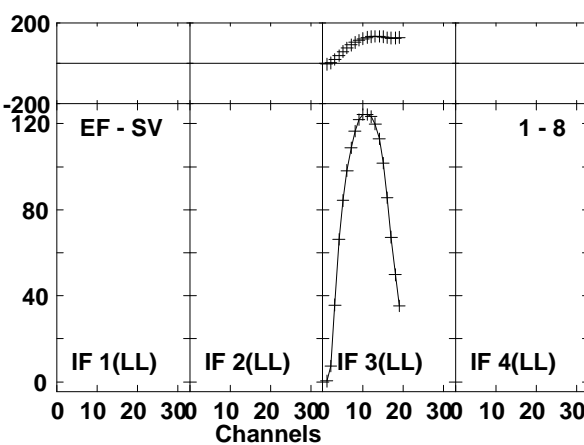
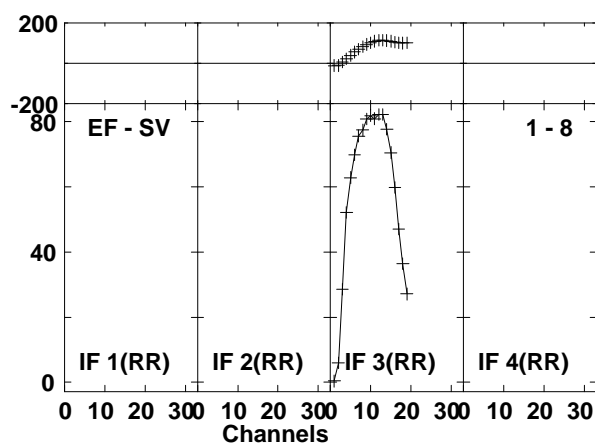
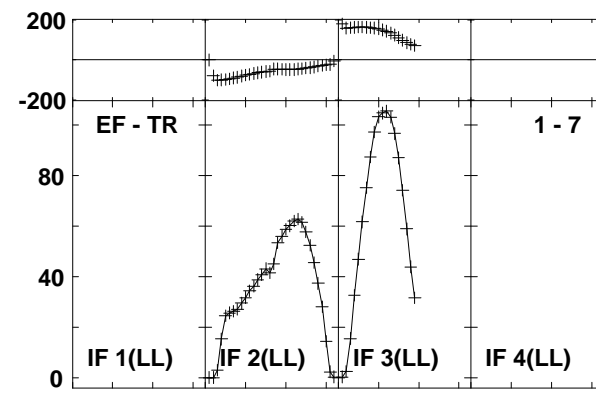
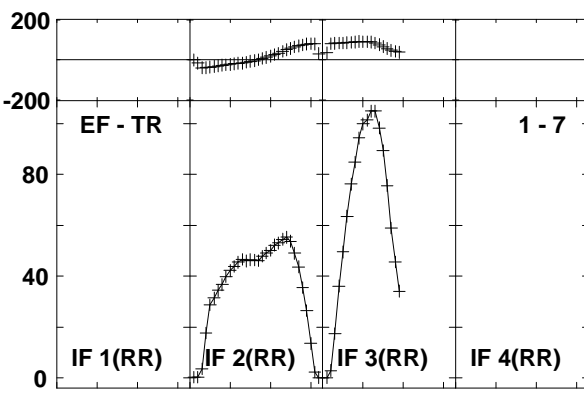
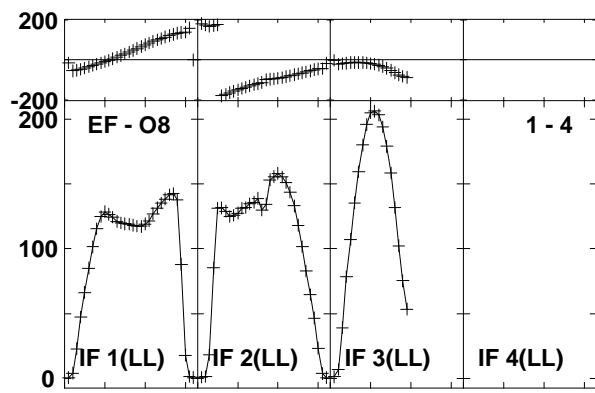
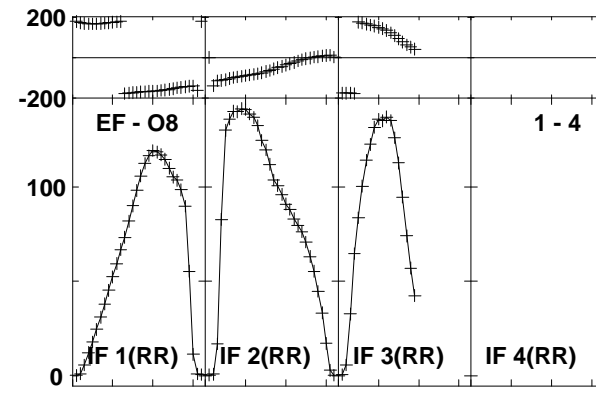
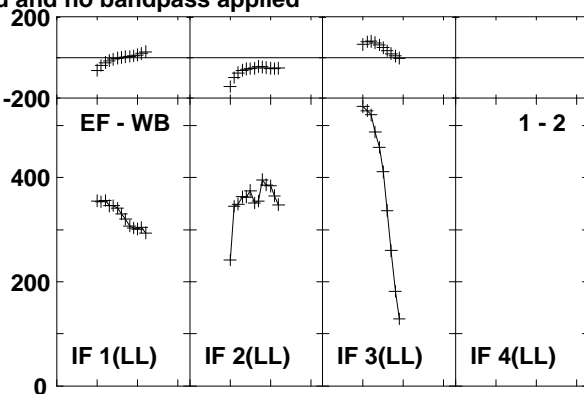
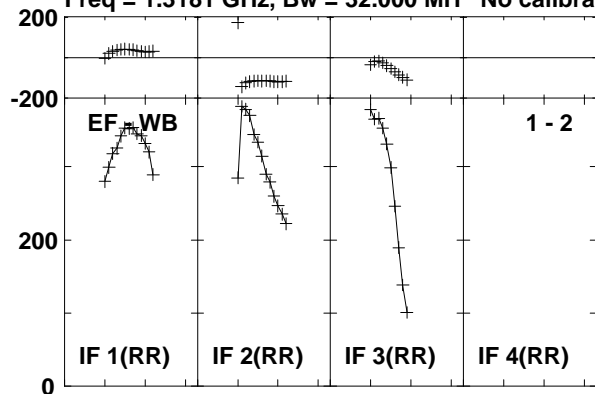

Lower frame: Milli Ampl Jy Top frame: Phas deg
Vector averaged cross-power spectrum Baseline: EF (01) - WB (02)
Timerange: 00/04:19:23 to 00/04:24:18

Plot file version 32 created 20-NOV-2015 13:43:51

3C454.3 EO013 1.UVDATA.1

Freq = 1.3181 GHz, Bw = 32.000 MH No calibration applied and no bandpass applied

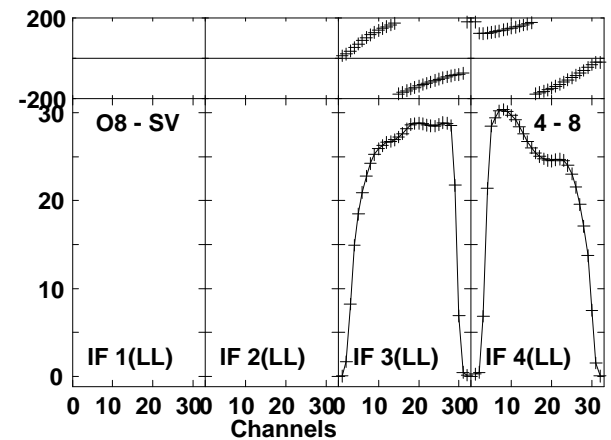
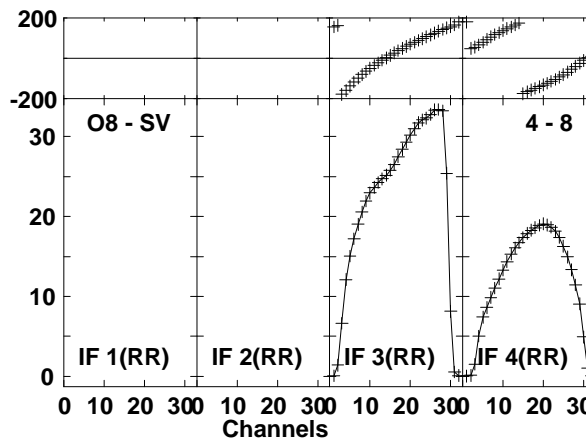
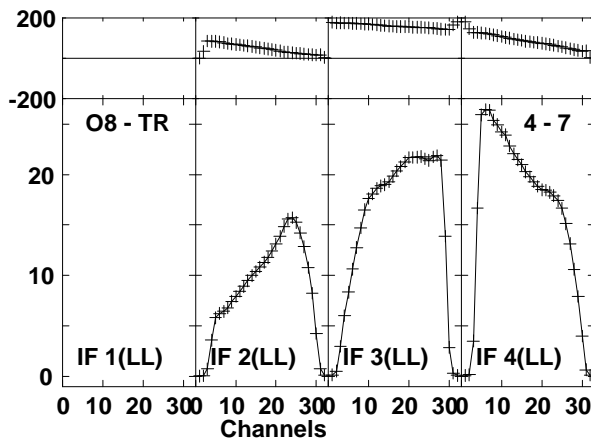
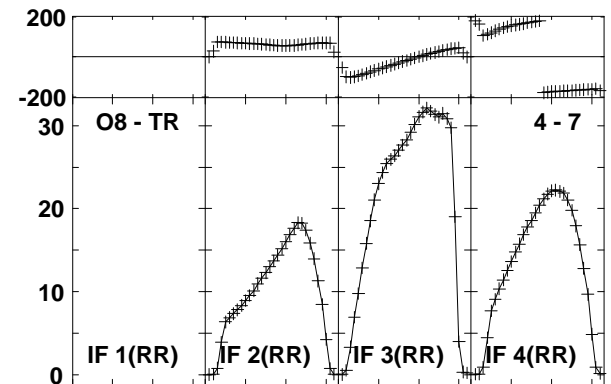
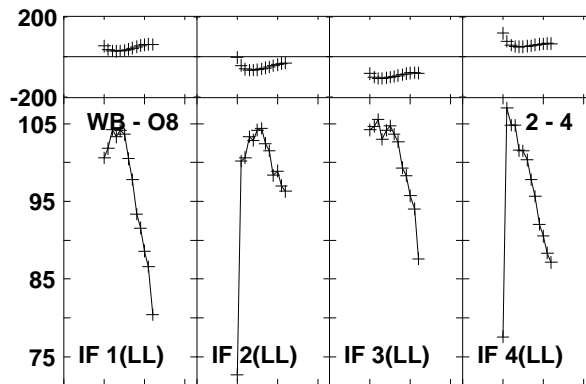
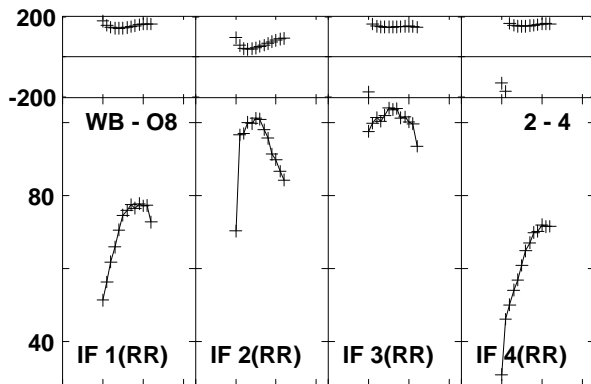
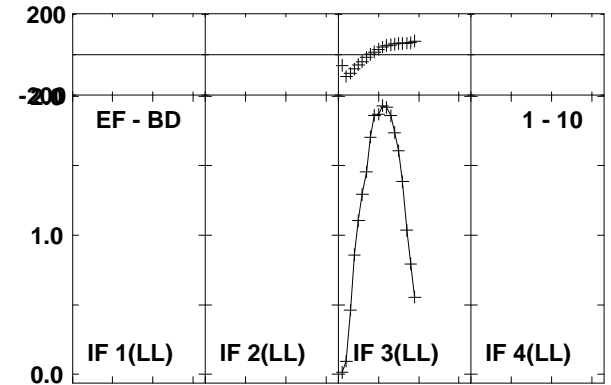
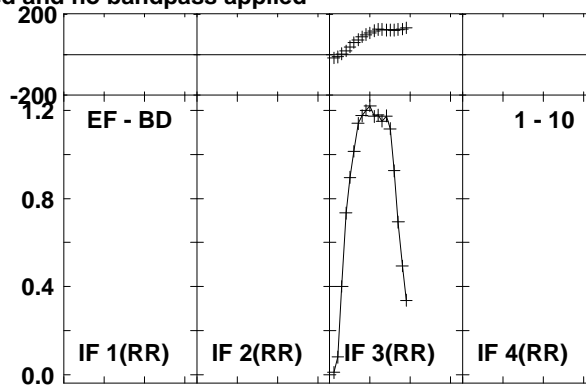
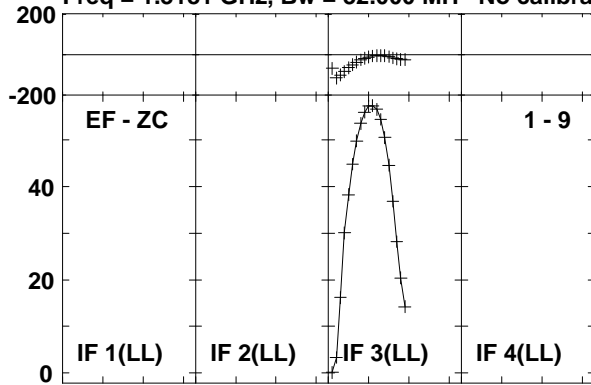

Lower frame: Milli Ampl Jy Top frame: Phas deg
Vector averaged cross-power spectrum Baseline: EF (01) - ZC (09)
Timerange: 00/04:19:23 to 00/04:24:18

Plot file version 33 created 20-NOV-2015 13:43:51
 3C454.3 EO013 1.UVDATA.1
 Freq = 1.3181 GHz, Bw = 32.000 MH No calibration applied and no bandpass applied

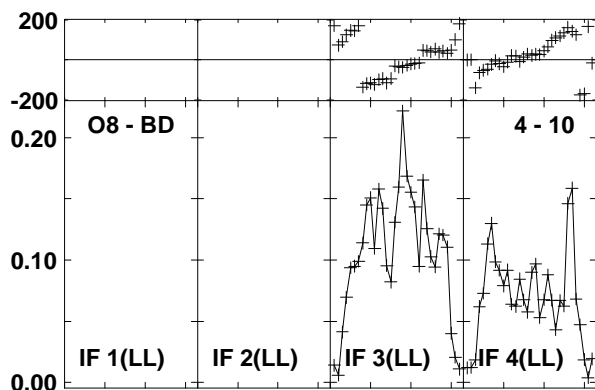
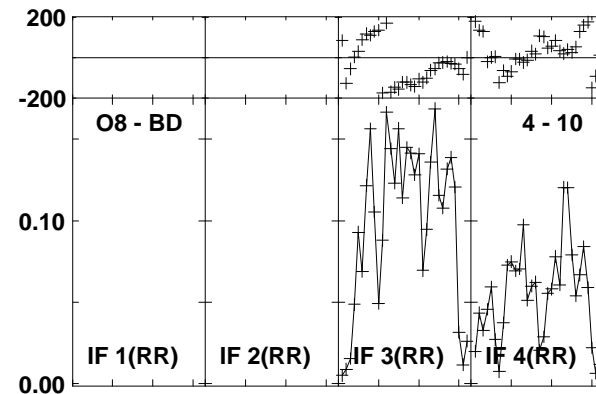
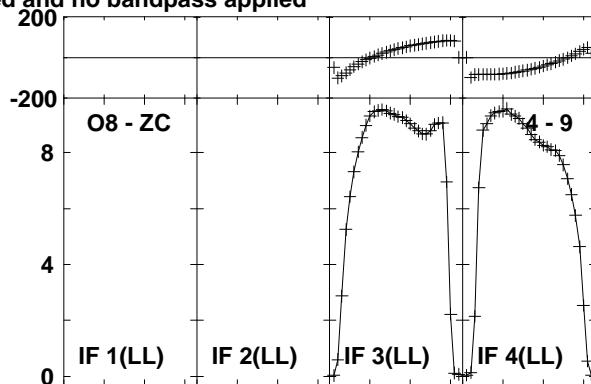
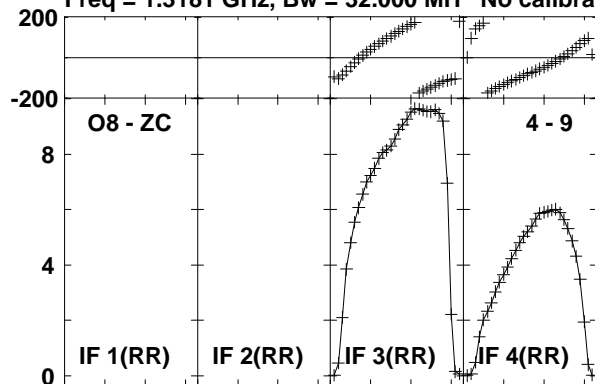

Lower frame: Milli Ampl Jy Top frame: Phas deg
 Vector averaged cross-power spectrum Baseline: O8 (04) - ZC (09)
 Timerange: 00/04:19:23 to 00/04:24:18

Plot file version 34 created 20-NOV-2015 13:43:51

3C454.3 EO013 1.UVDATA.1

Freq = 1.3181 GHz, Bw = 32.000 MH No calibration applied and no bandpass applied

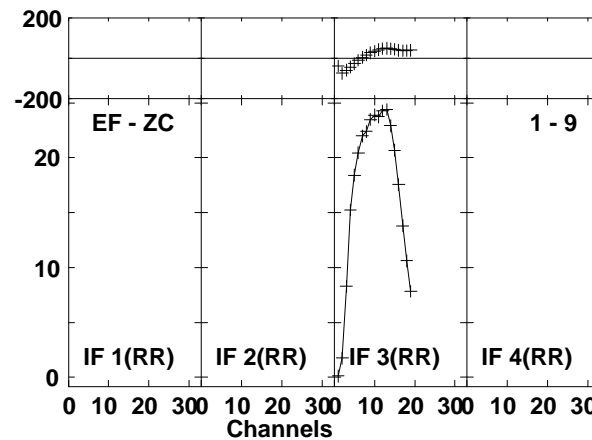
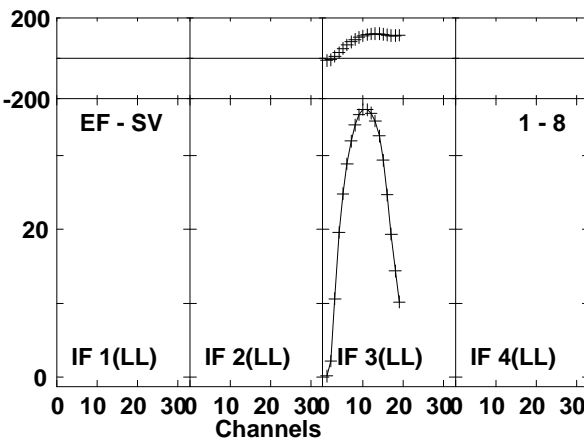
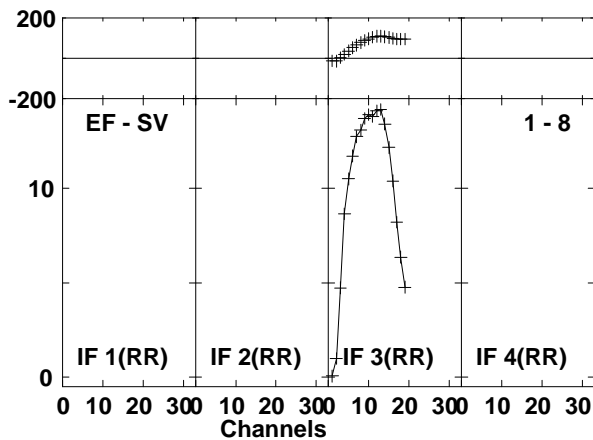
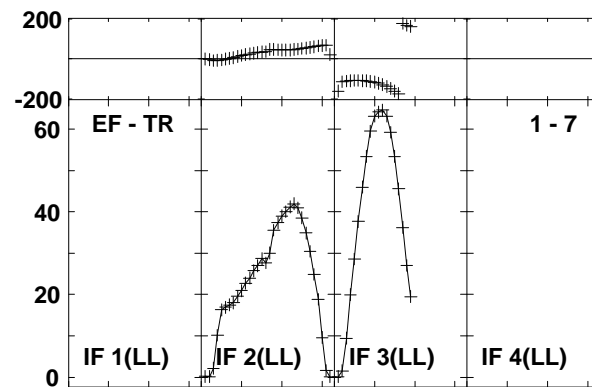
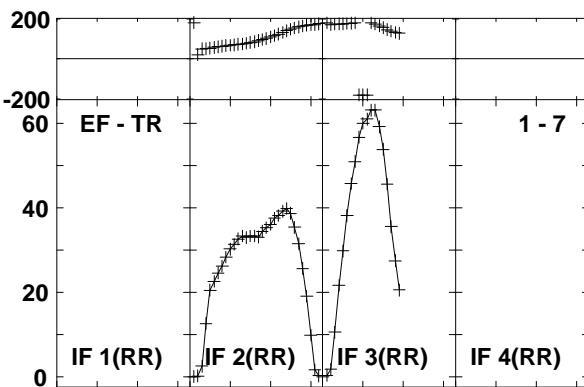
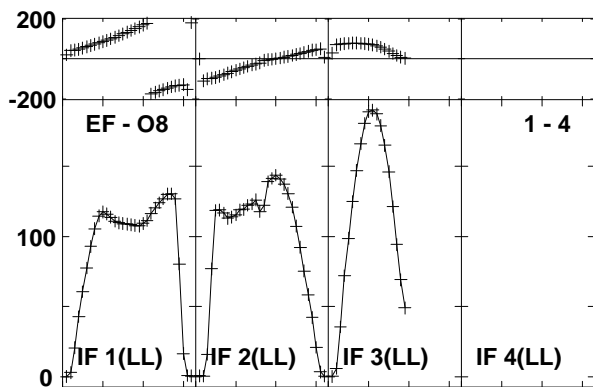
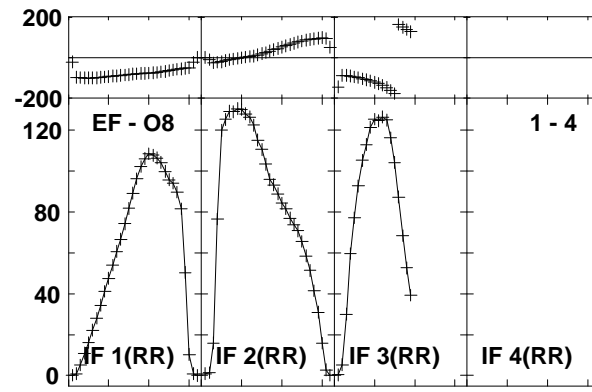
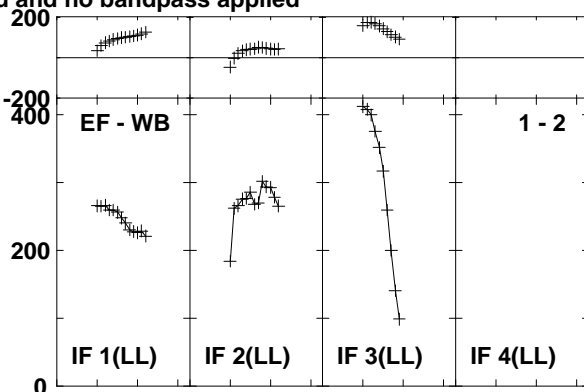
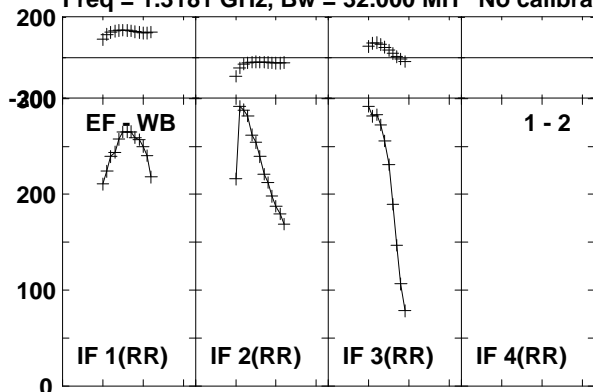

Lower frame: Milli Ampl Jy Top frame: Phas deg
Vector averaged cross-power spectrum Baseline: EF (01) - WB (02)
Timerange: 00/04:24:53 to 00/04:34:49

Plot file version 35 created 20-NOV-2015 13:43:51

3C454.3 EO013 1.UVDATA.1

Freq = 1.3181 GHz, Bw = 32.000 MH No calibration applied and no bandpass applied

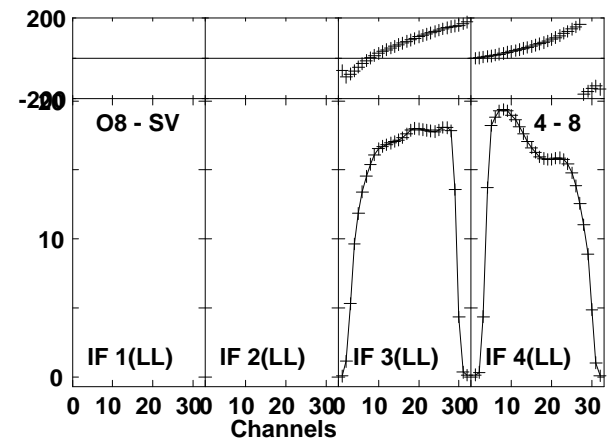
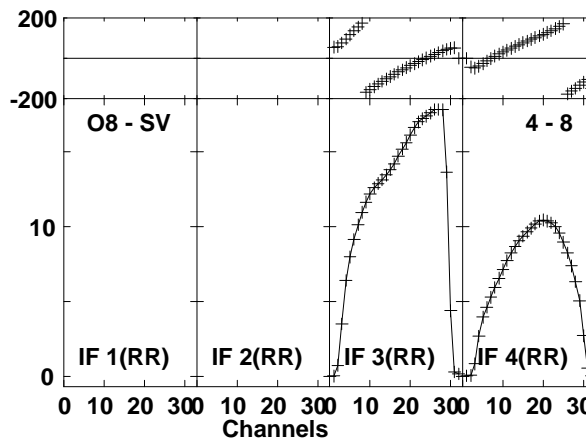
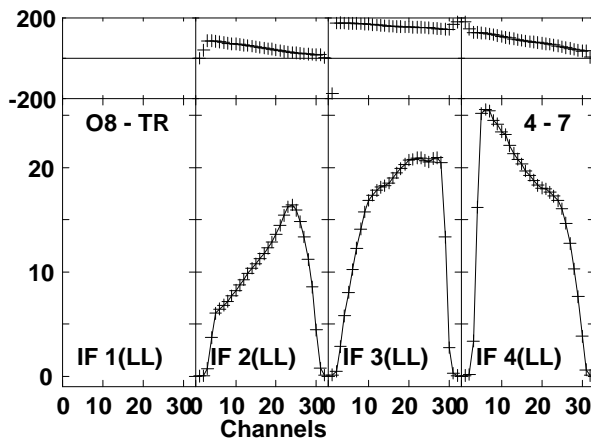
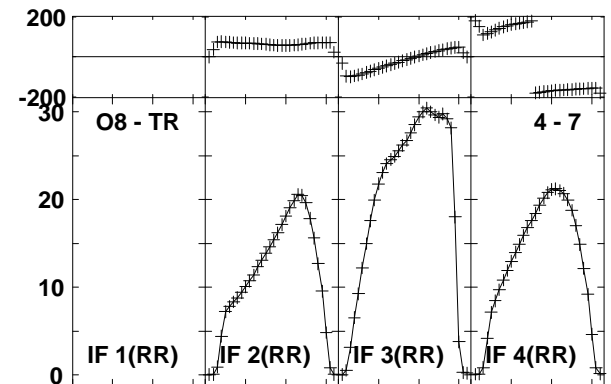
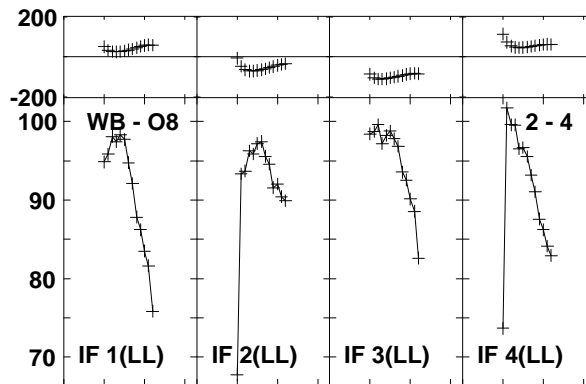
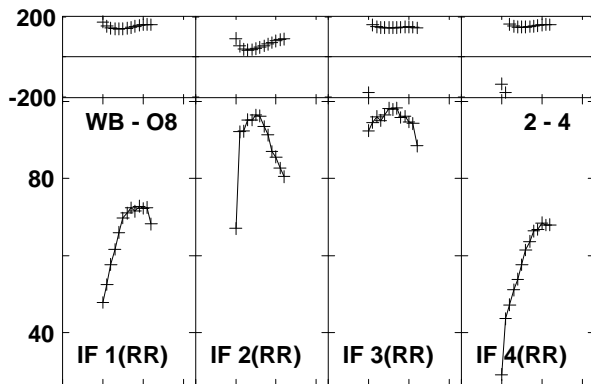
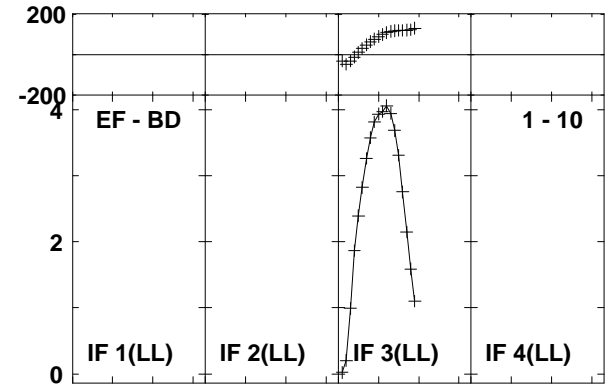
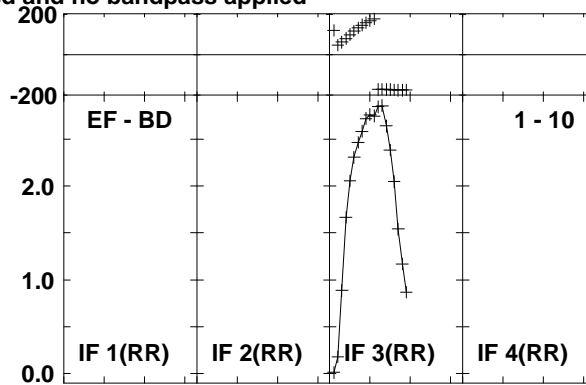
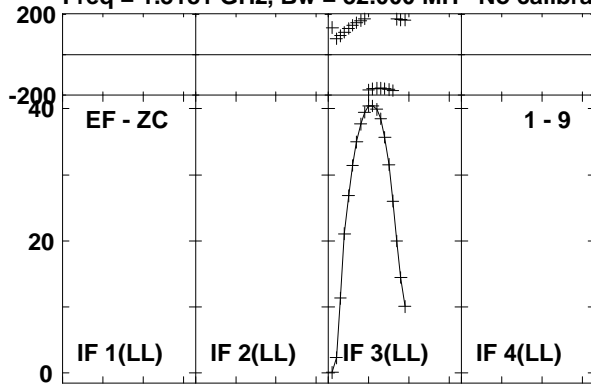

Lower frame: Milli Ampl Jy Top frame: Phas deg
Vector averaged cross-power spectrum Baseline: EF (01) - ZC (09)
Timerange: 00/04:24:53 to 00/04:34:49

Plot file version 36 created 20-NOV-2015 13:43:51
 3C454.3 EO013 1.UVDATA.1
 Freq = 1.3181 GHz, Bw = 32.000 MH No calibration applied and no bandpass applied

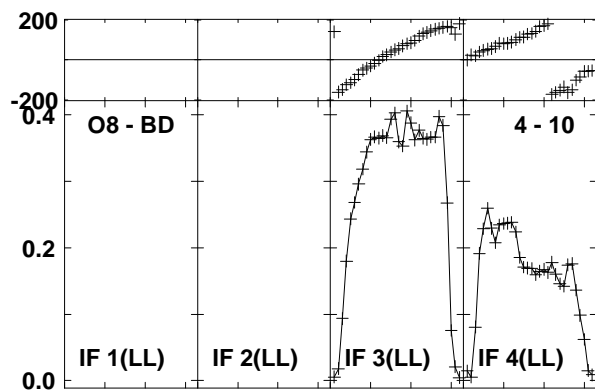
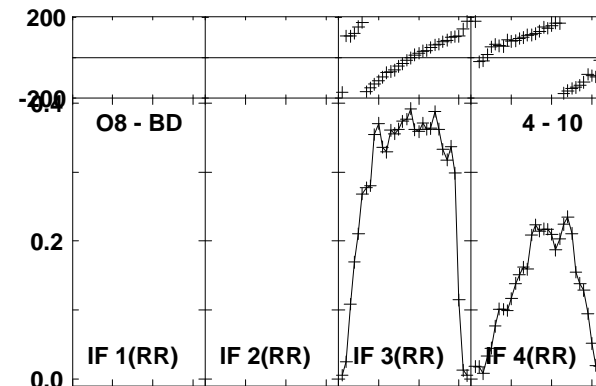
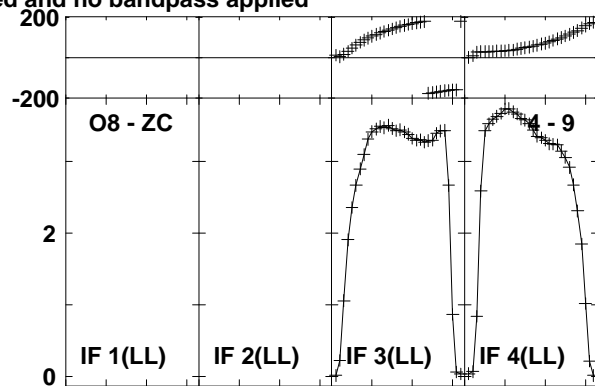
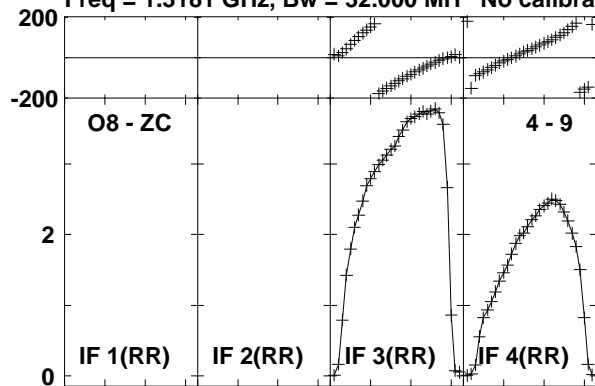

Lower frame: Milli Ampl Jy Top frame: Phas deg
 Vector averaged cross-power spectrum Baseline: O8 (04) - ZC (09)
 Timerange: 00/04:24:53 to 00/04:34:49

Plot file version 37 created 20-NOV-2015 13:43:51

3C84 EO013 1.UVDATA.1

Freq = 1.3181 GHz, Bw = 32.000 MH No calibration applied and no bandpass applied

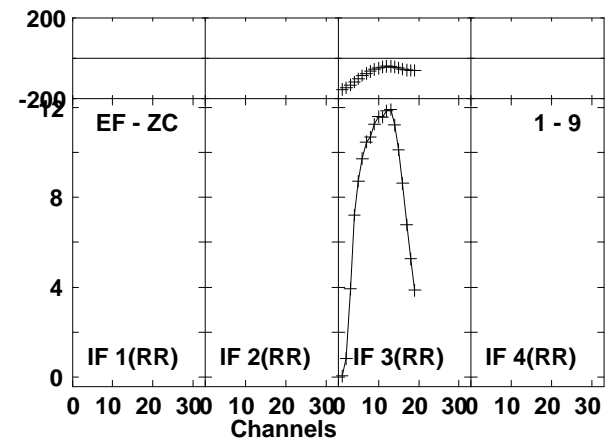
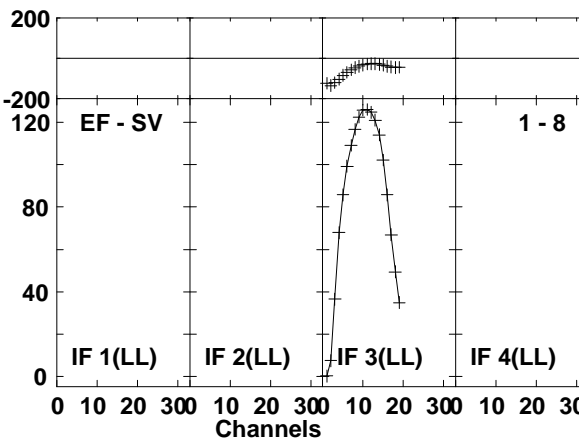
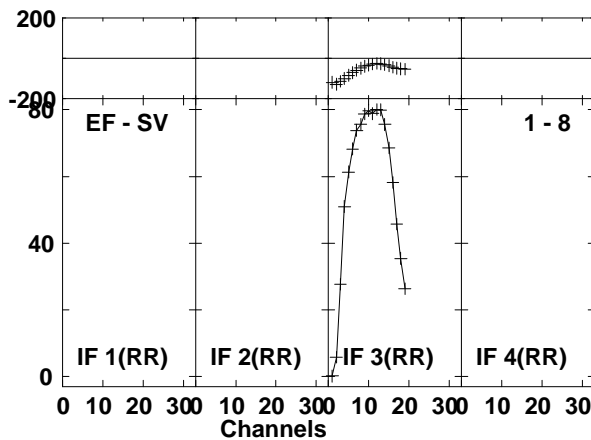
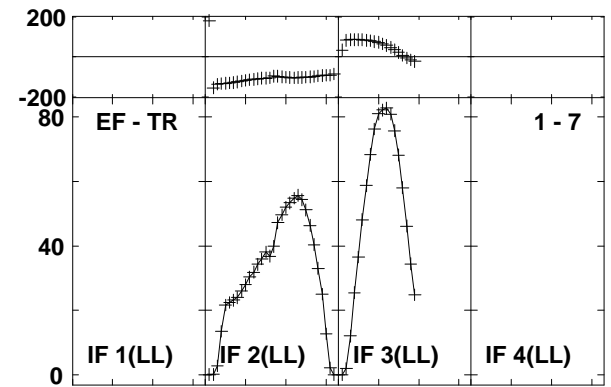
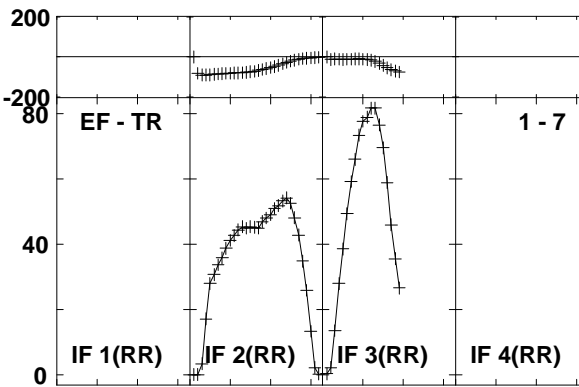
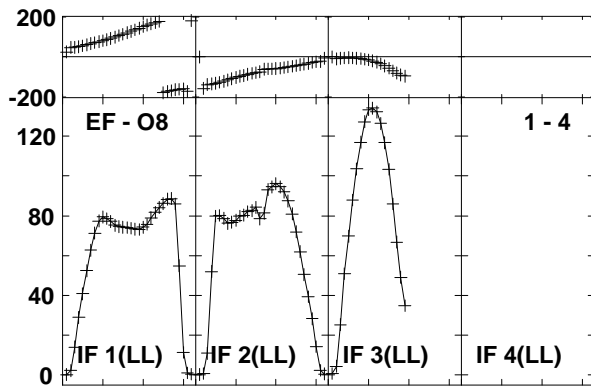
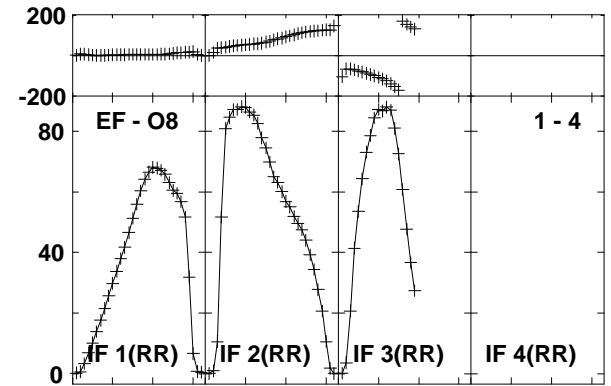
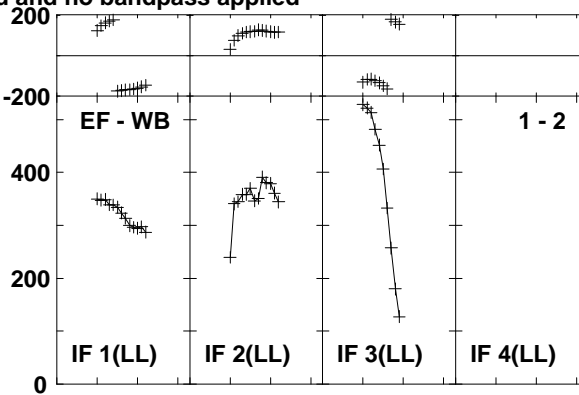
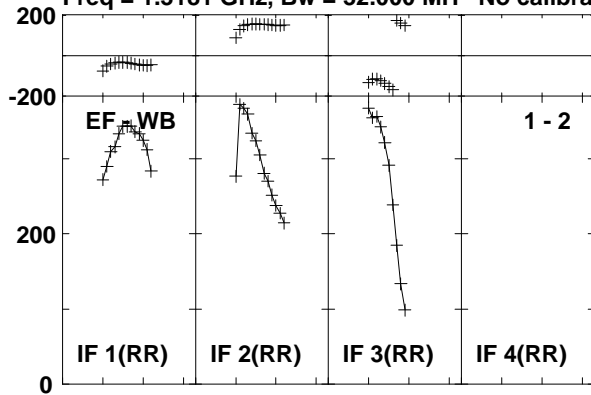

Lower frame: Milli Ampl Jy Top frame: Phas deg
Vector averaged cross-power spectrum Baseline: EF (01) - WB (02)
Timerange: 00/04:39:33 to 00/04:49:28

Plot file version 38 created 20-NOV-2015 13:43:51
 3C84 EO013 1.UVDATA.1
 Freq = 1.3181 GHz, Bw = 32.000 MH No calibration applied and no bandpass applied

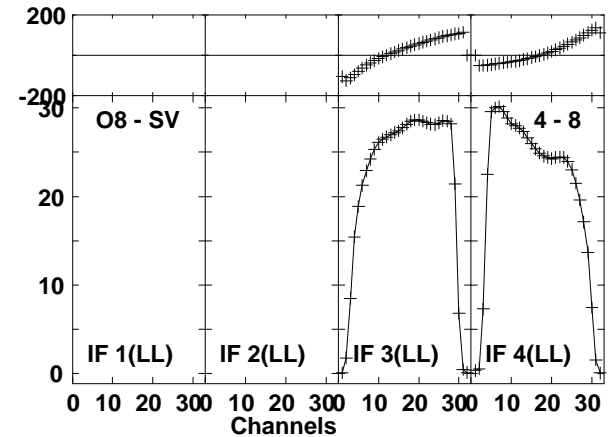
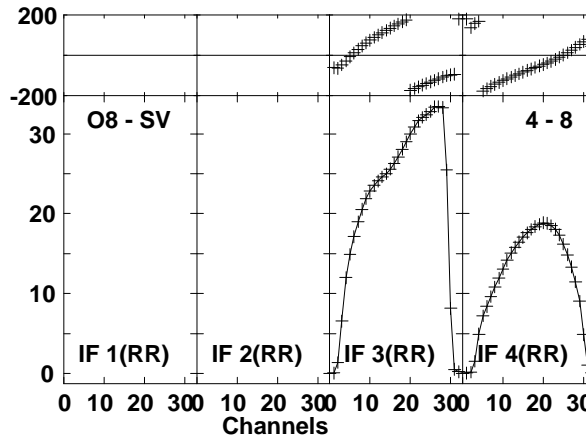
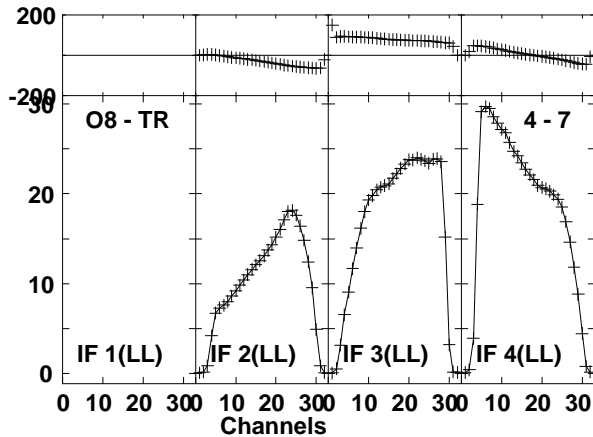
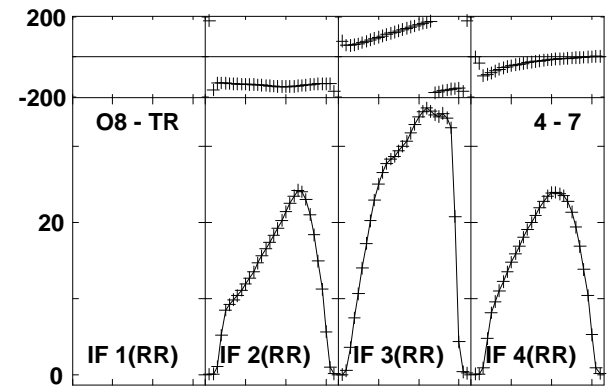
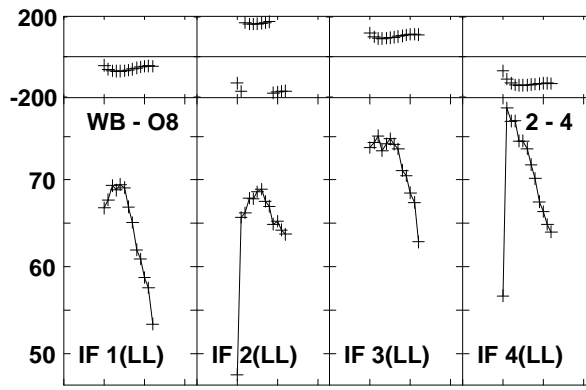
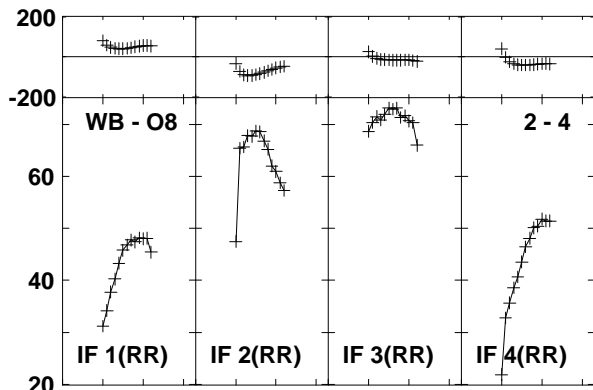
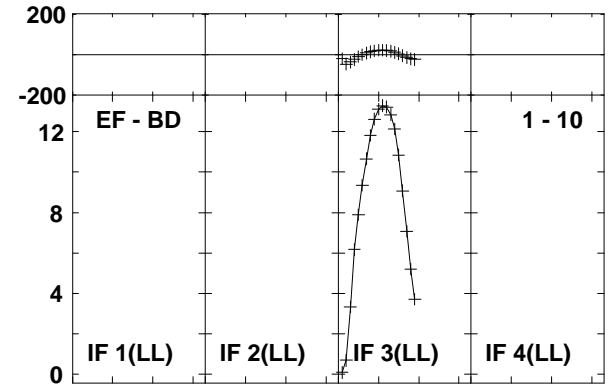
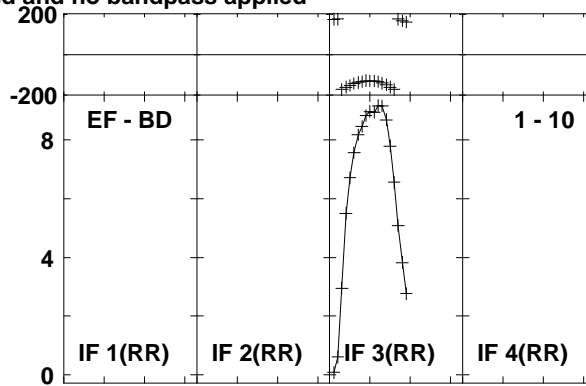
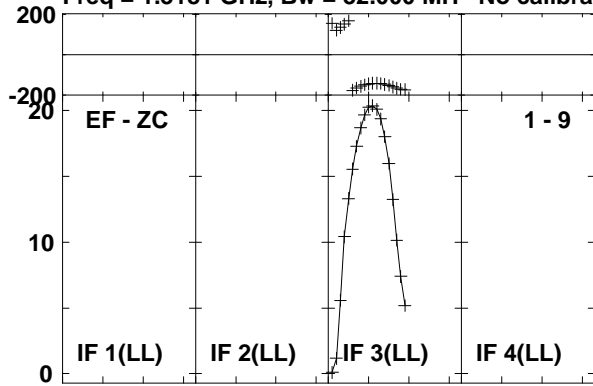

Lower frame: Milli Ampl Jy Top frame: Phas deg
 Vector averaged cross-power spectrum Baseline: EF (01) - ZC (09)
 Timerange: 00/04:39:33 to 00/04:49:28

Plot file version 39 created 20-NOV-2015 13:43:51
 3C84 EO013 1.UVDATA.1
 Freq = 1.3181 GHz, Bw = 32.000 MH No calibration applied and no bandpass applied

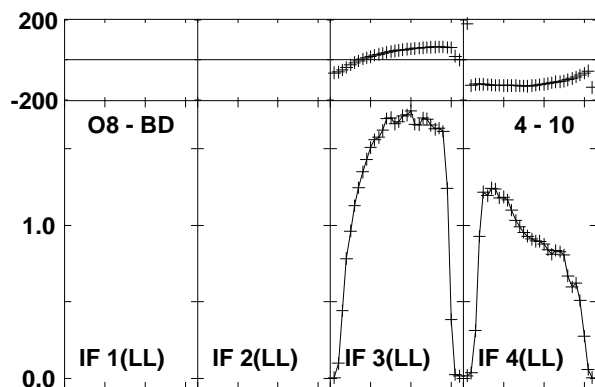
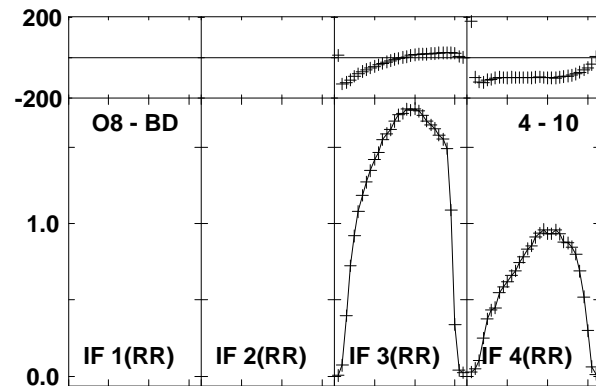
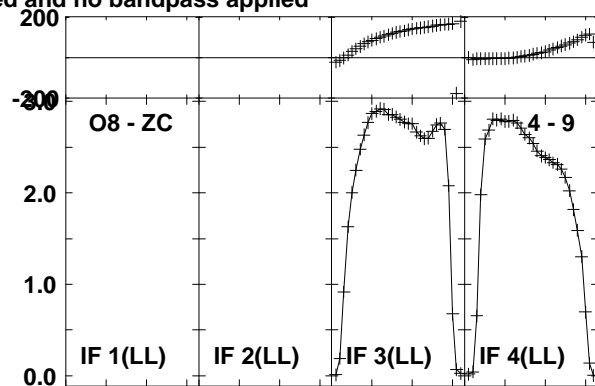
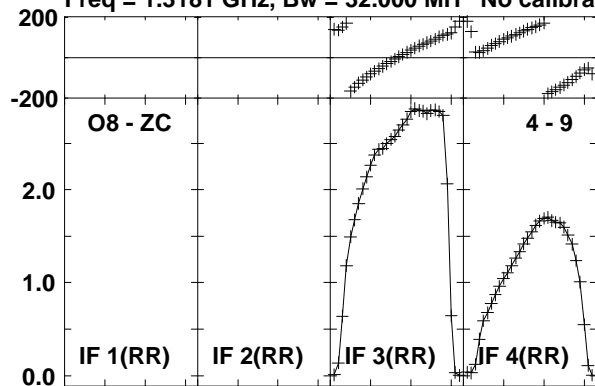

Lower frame: Milli Ampl Jy Top frame: Phas deg
 Vector averaged cross-power spectrum Baseline: O8 (04) - ZC (09)
 Timerange: 00/04:39:33 to 00/04:49:28

Plot file version 40 created 20-NOV-2015 13:43:51

3C84 EO013 1.UVDATA.1

Freq = 1.3181 GHz, Bw = 32.000 MH No calibration applied and no bandpass applied

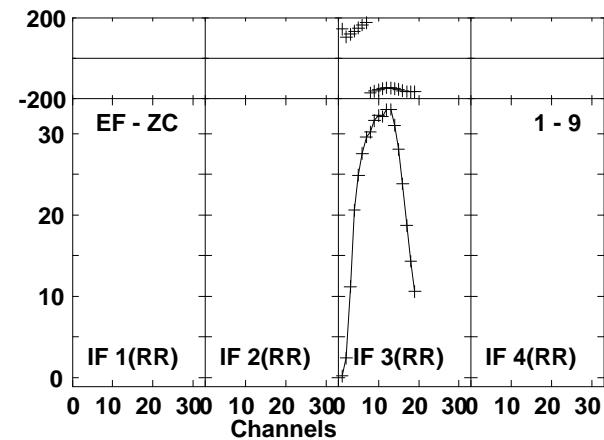
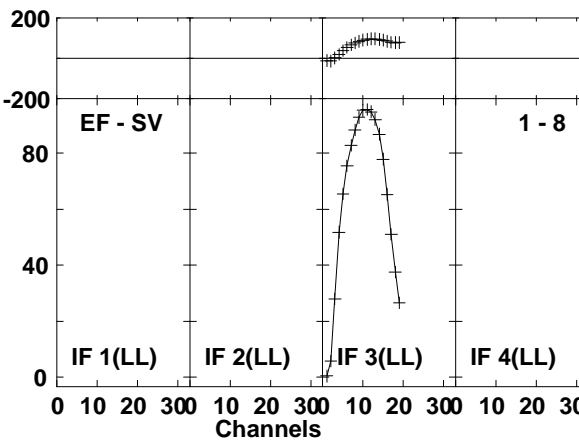
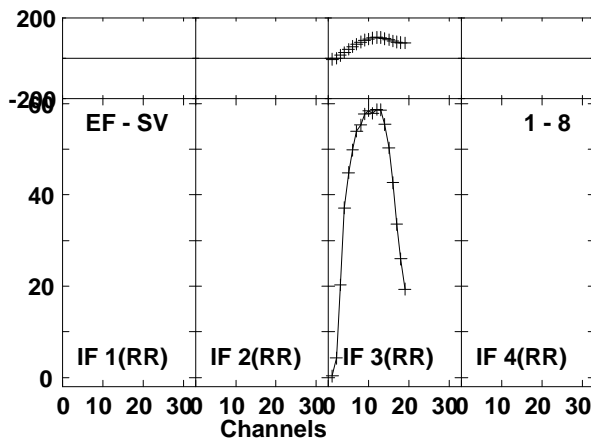
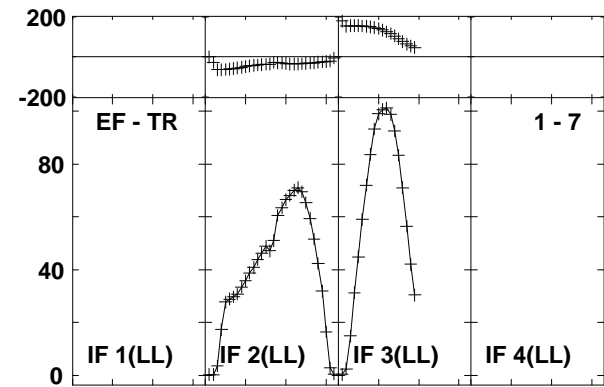
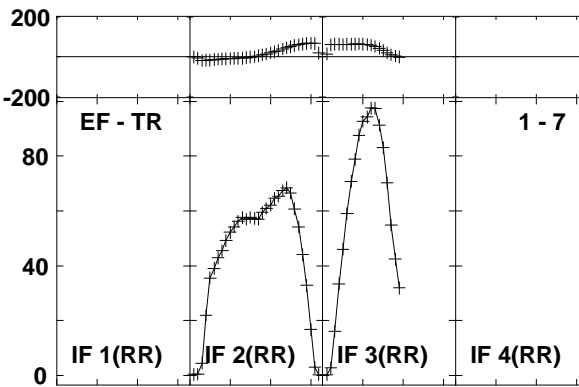
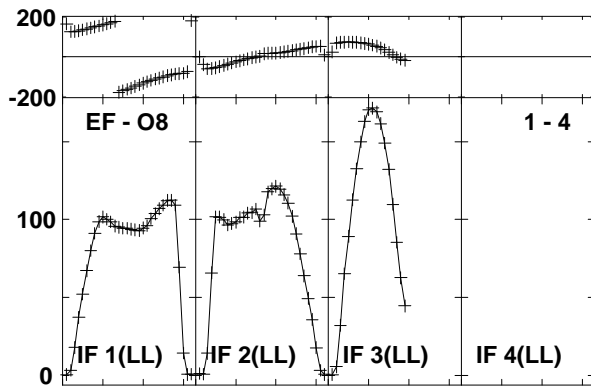
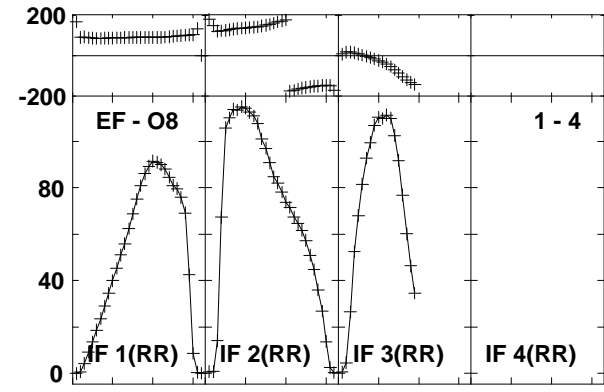
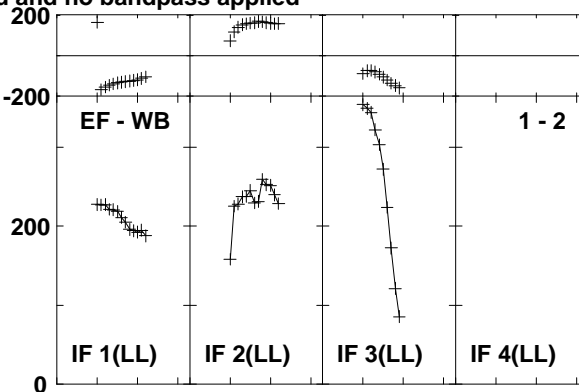
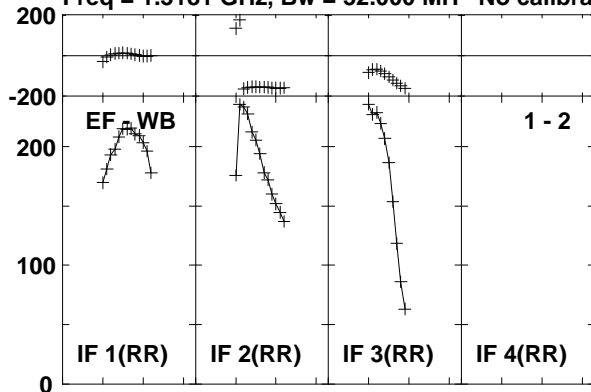

Lower frame: Milli Ampl Jy Top frame: Phas deg
Vector averaged cross-power spectrum Baseline: EF (01) - WB (02)
Timerange: 00/04:50:03 to 00/04:59:59

Plot file version 41 created 20-NOV-2015 13:43:52
 3C84 EO013 1.UVDATA.1
 Freq = 1.3181 GHz, Bw = 32.000 MH No calibration applied and no bandpass applied

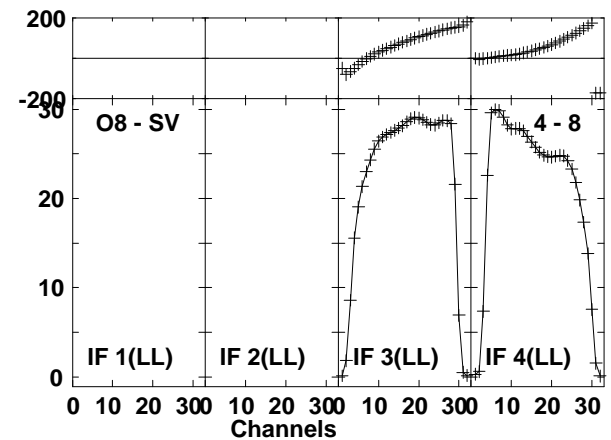
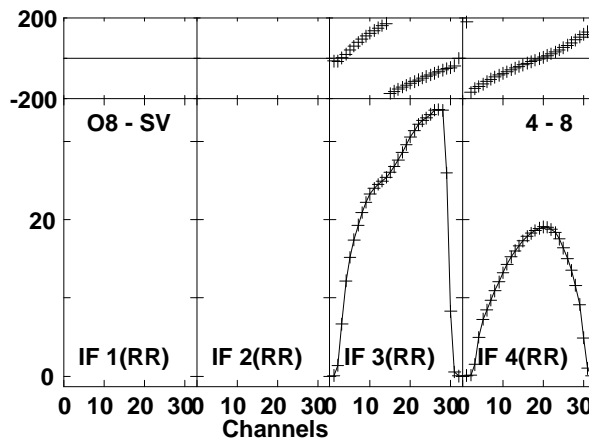
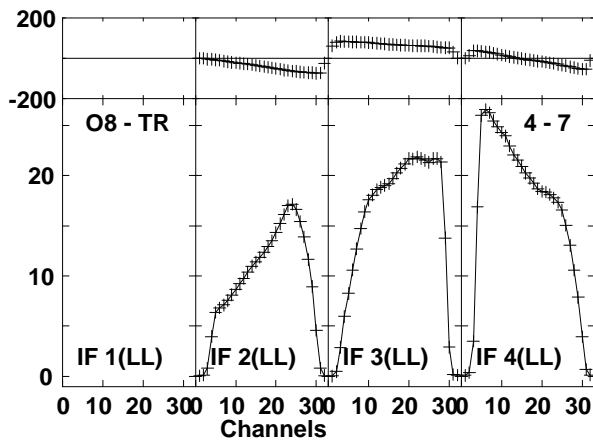
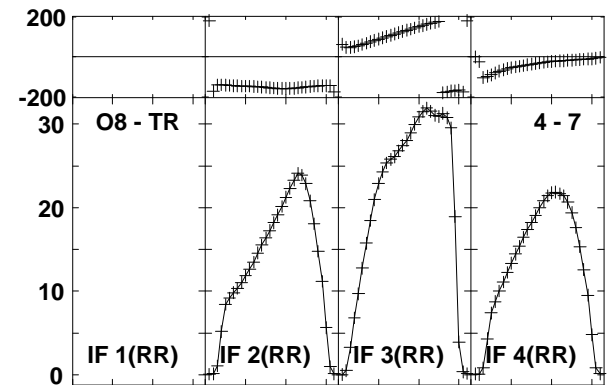
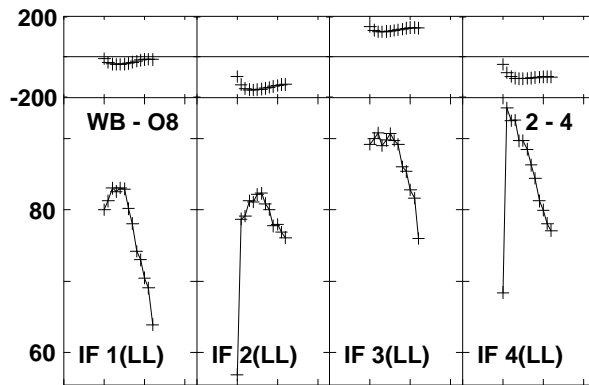
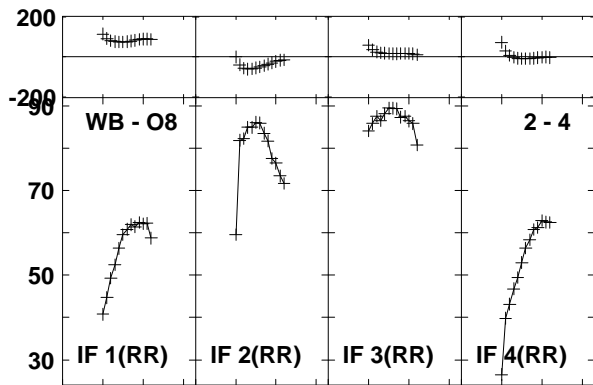
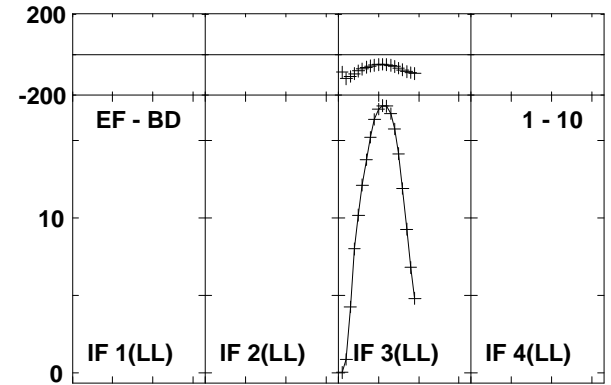
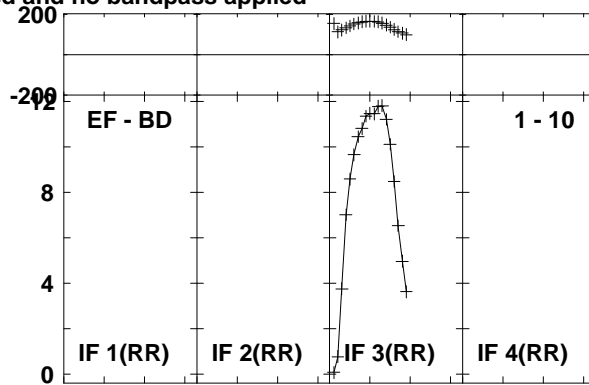
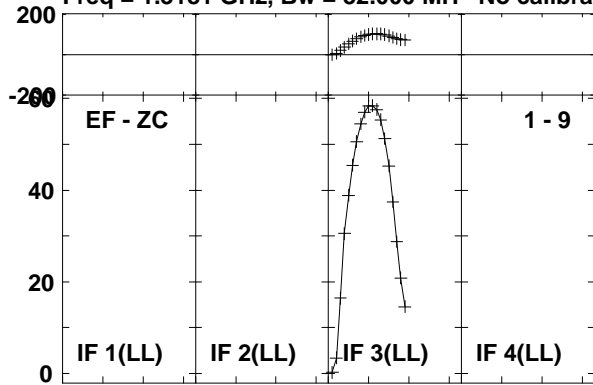

Lower frame: Milli Ampl Jy Top frame: Phas deg
 Vector averaged cross-power spectrum Baseline: EF (01) - ZC (09)
 Timerange: 00/04:50:03 to 00/04:59:59

Plot file version 42 created 20-NOV-2015 13:43:52
 3C84 EO013 1.UVDATA.1
 Freq = 1.3181 GHz, Bw = 32.000 MH No calibration applied and no bandpass applied

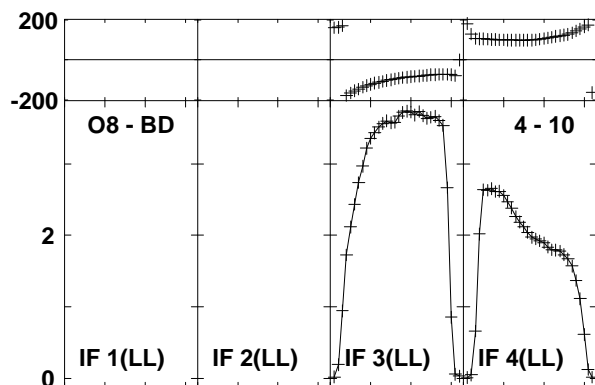
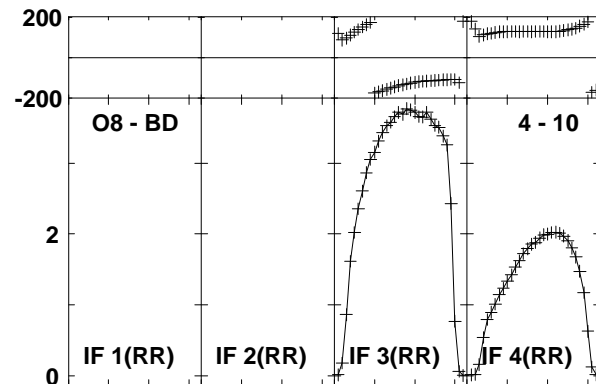
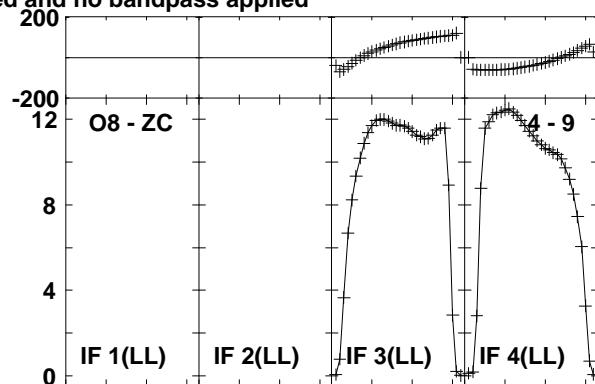
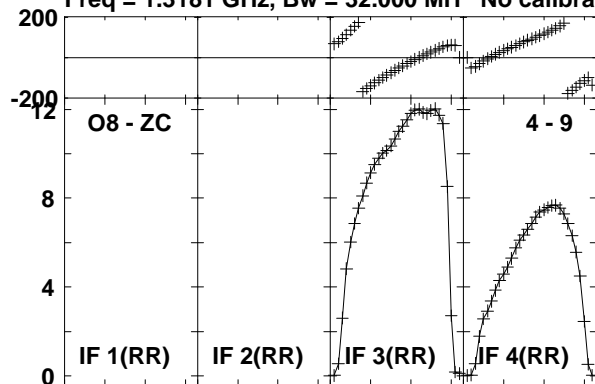

Lower frame: Milli Ampl Jy Top frame: Phas deg
 Vector averaged cross-power spectrum Baseline: O8 (04) - ZC (09)
 Timerange: 00/04:50:03 to 00/04:59:59

Plot file version 43 created 20-NOV-2015 13:43:52
 3C84 EO013 1.UVDATA.1
 Freq = 1.3181 GHz, Bw = 32.000 MH No calibration applied and no bandpass applied

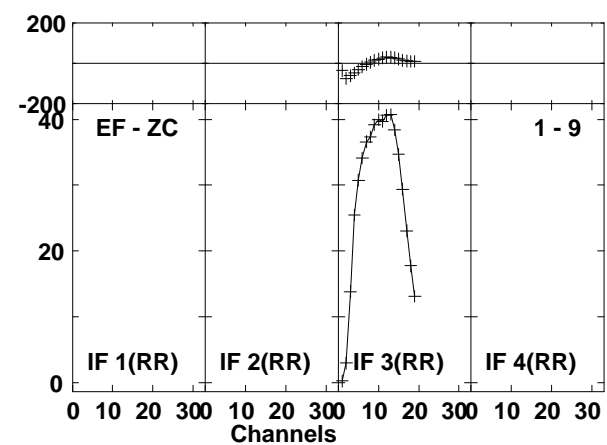
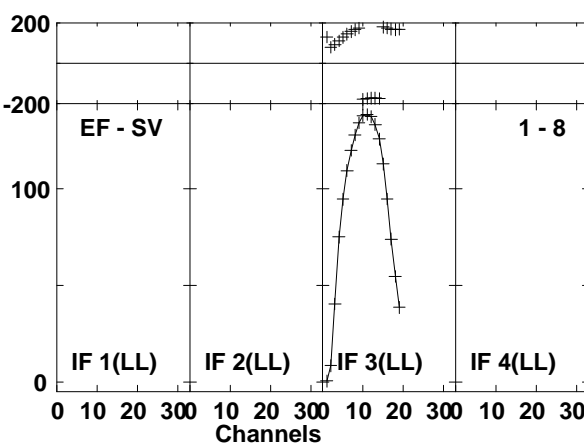
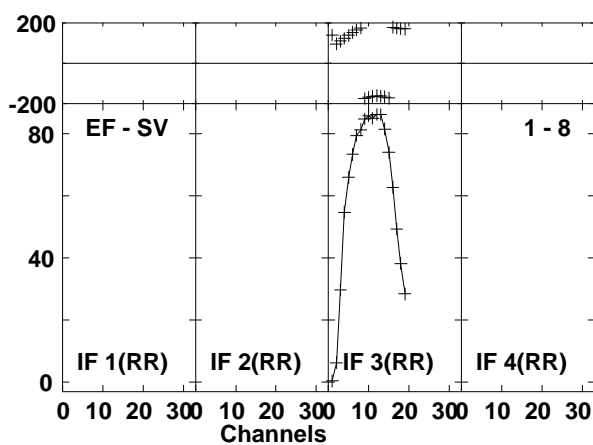
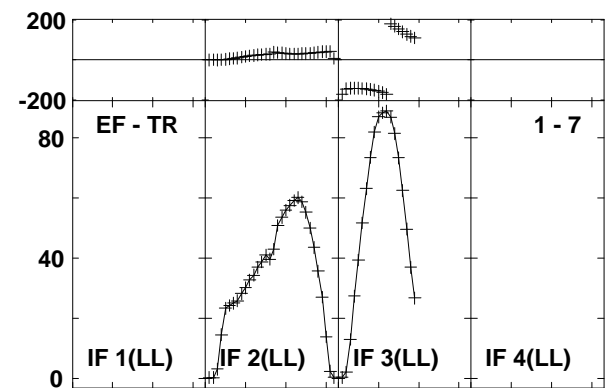
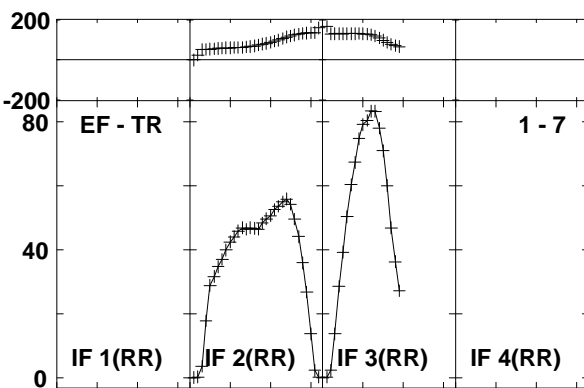
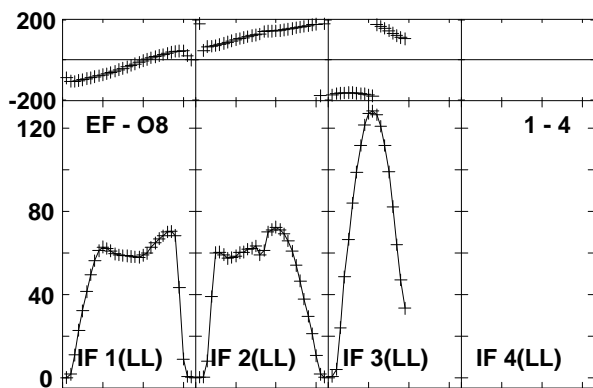
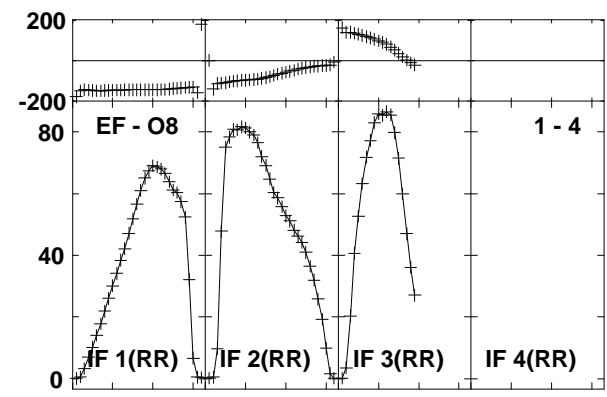
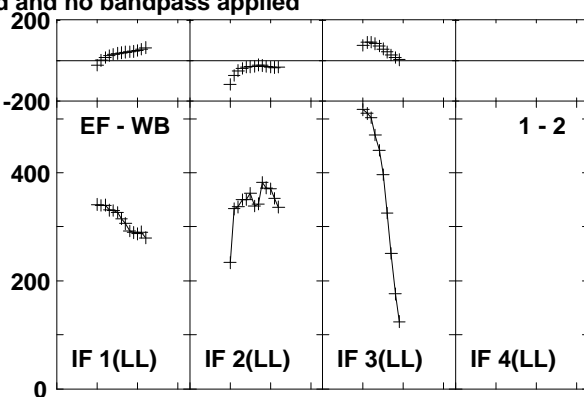
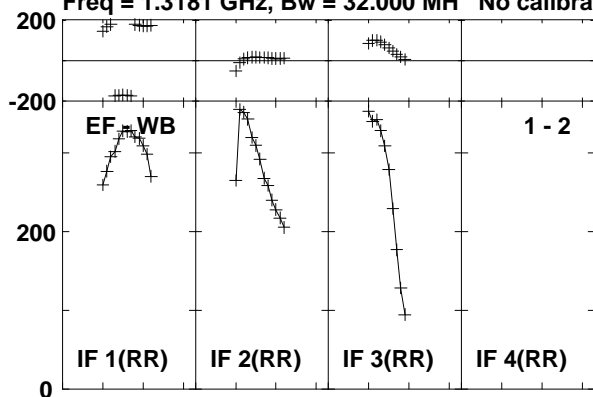

Lower frame: Milli Ampl Jy Top frame: Phas deg
 Vector averaged cross-power spectrum Baseline: EF (01) - WB (02)
 Timerange: 00/05:00:33 to 00/05:10:29

Plot file version 44 created 20-NOV-2015 13:43:52
 3C84 EO013 1.UVDATA.1
 Freq = 1.3181 GHz, Bw = 32.000 MH No calibration applied and no bandpass applied

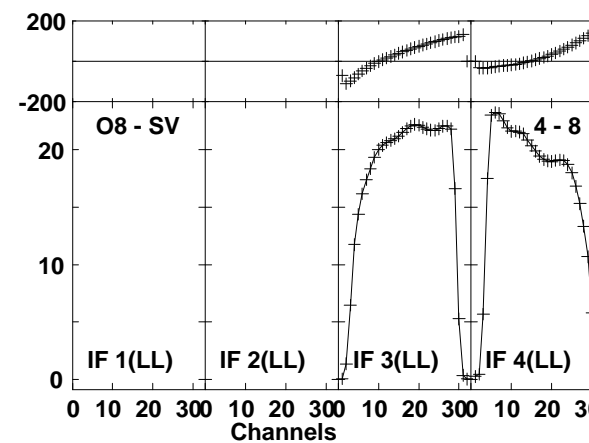
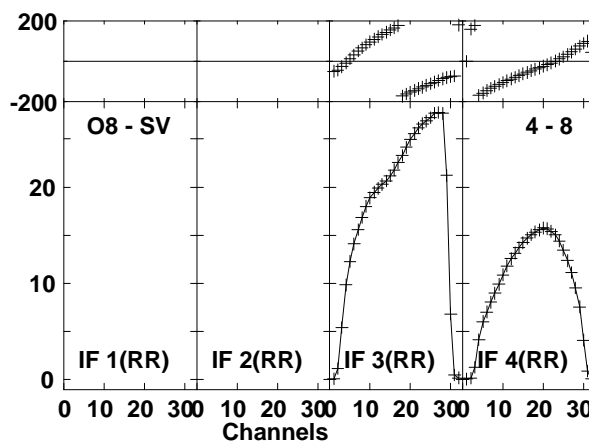
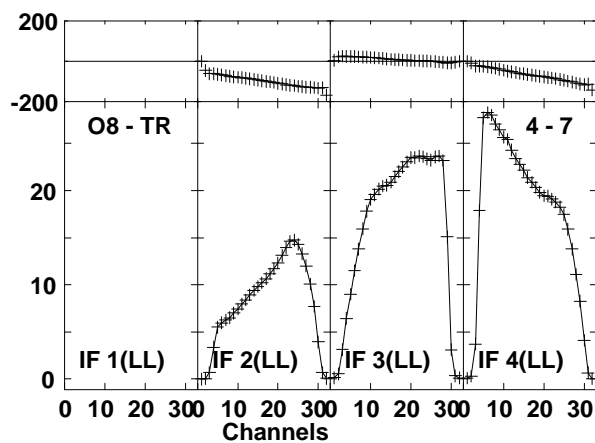
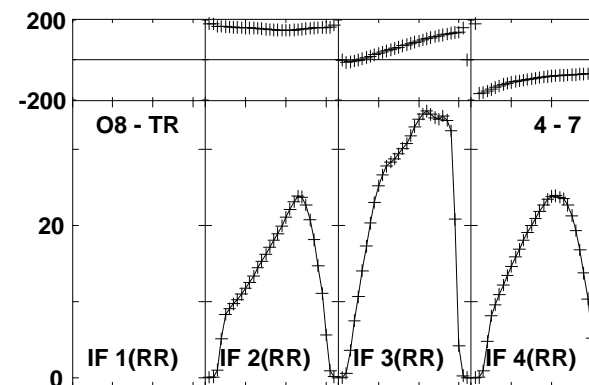
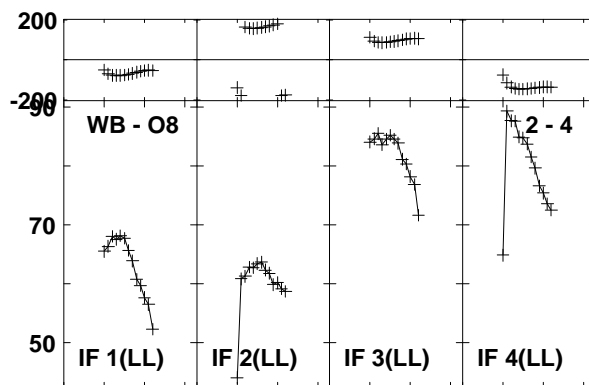
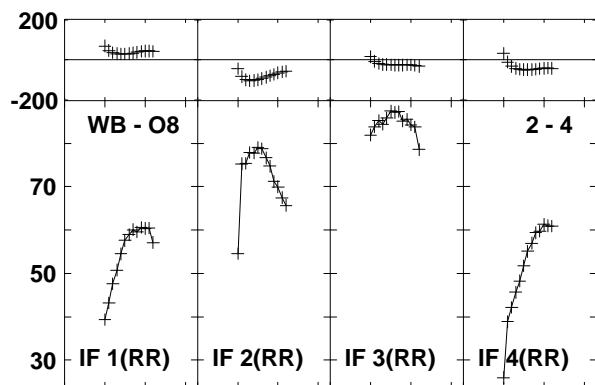
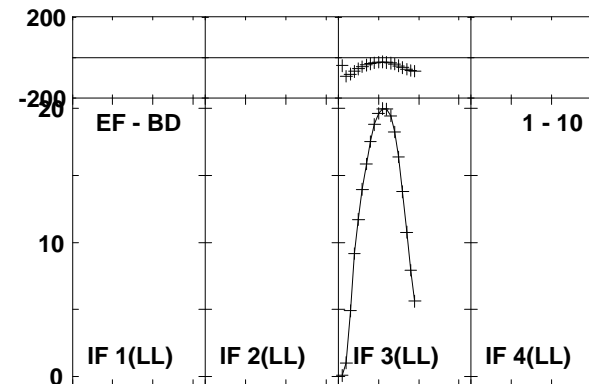
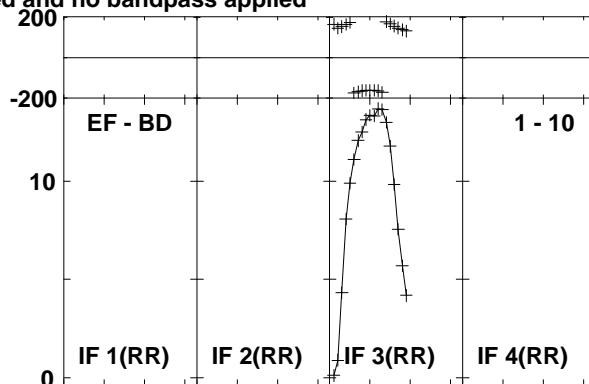
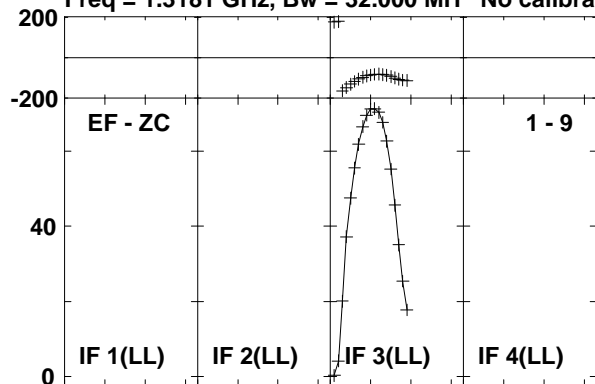

Lower frame: Milli Ampl Jy Top frame: Phas deg
 Vector averaged cross-power spectrum Baseline: EF (01) - ZC (09)
 Timerange: 00/05:00:33 to 00/05:10:29

Plot file version 45 created 20-NOV-2015 13:43:52
 3C84 EO013 1.UVDATA.1
 Freq = 1.3181 GHz, Bw = 32.000 MH No calibration applied and no bandpass applied

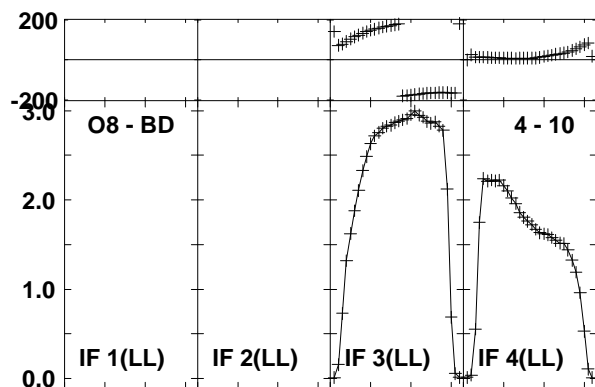
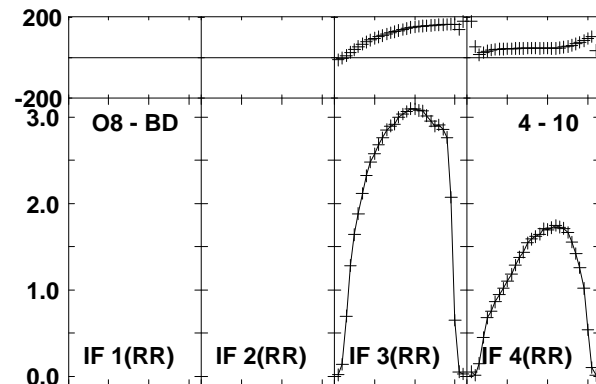
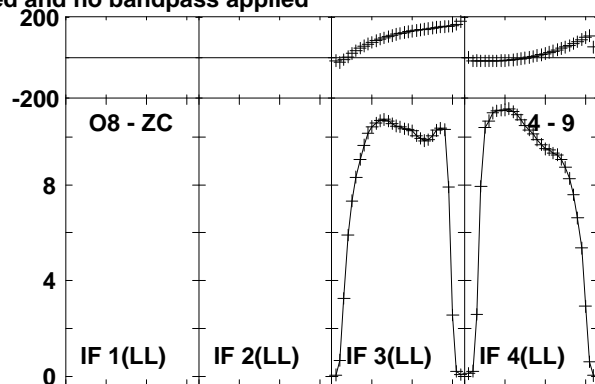
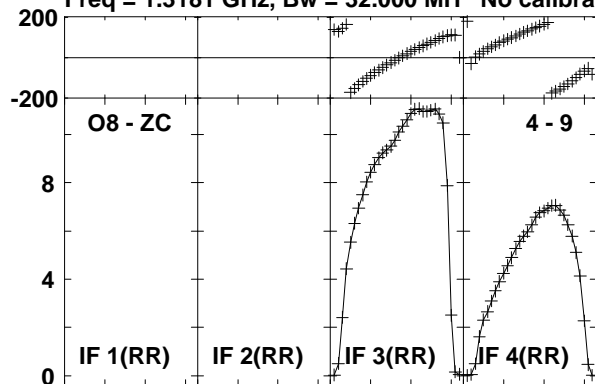

Lower frame: Milli Ampl Jy Top frame: Phas deg
 Vector averaged cross-power spectrum Baseline: O8 (04) - ZC (09)
 Timerange: 00/05:00:33 to 00/05:10:29

Plot file version 46 created 20-NOV-2015 13:43:52
 3C84 EO013 1.UVDATA.1
 Freq = 1.3181 GHz, Bw = 32.000 MH No calibration applied and no bandpass applied

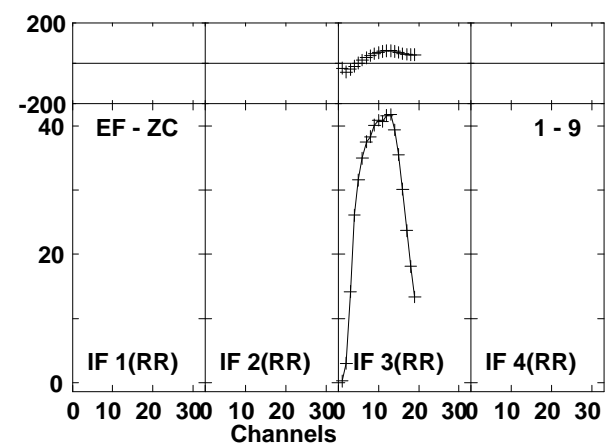
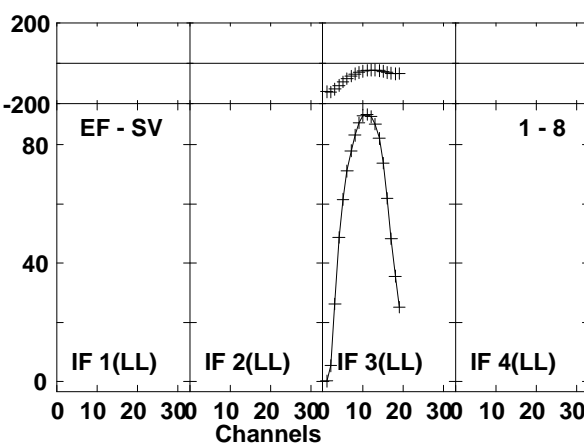
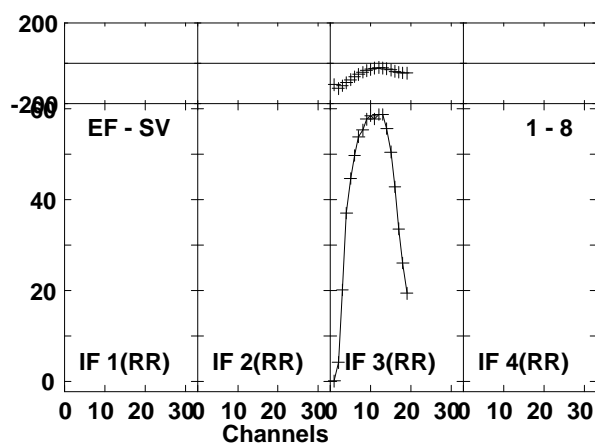
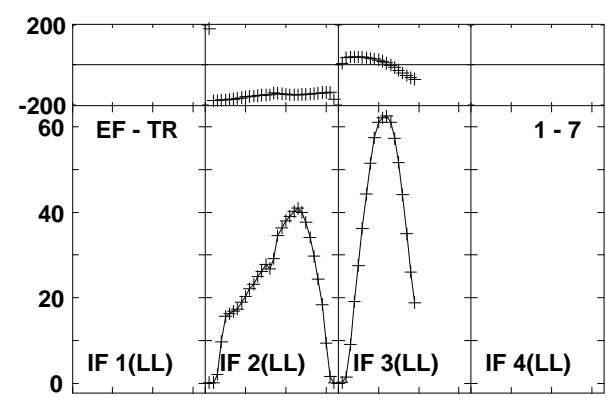
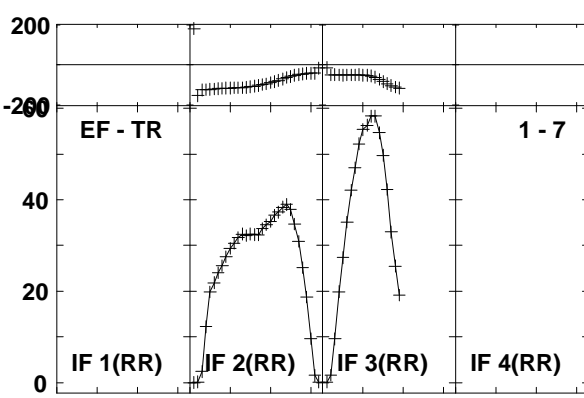
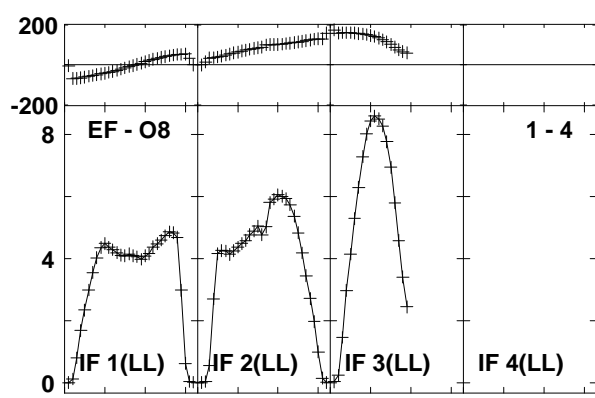
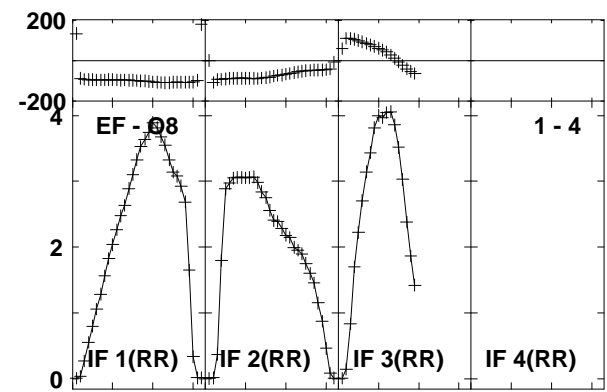
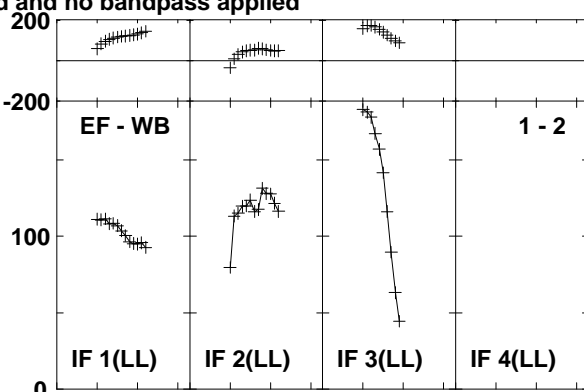
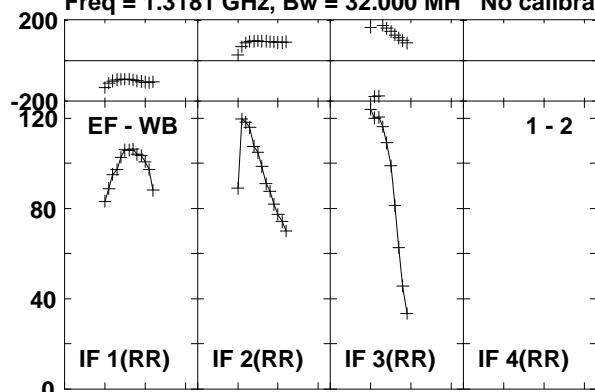

Lower frame: Milli Ampl Jy Top frame: Phas deg
 Vector averaged cross-power spectrum Baseline: EF (01) - WB (02)
 Timerange: 00/05:11:03 to 00/05:20:59

Plot file version 47 created 20-NOV-2015 13:43:52
 3C84 EO013 1.UVDATA.1
 Freq = 1.3181 GHz, Bw = 32.000 MH No calibration applied and no bandpass applied

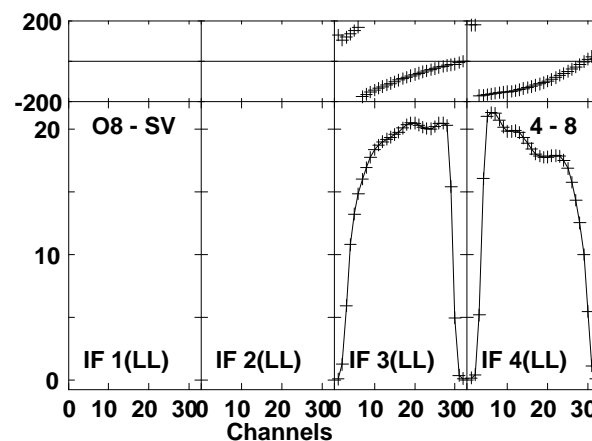
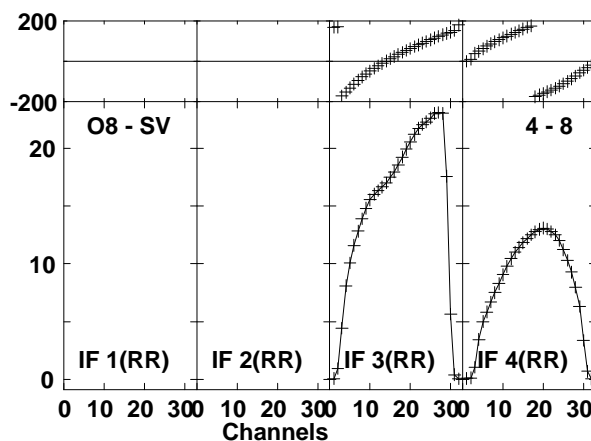
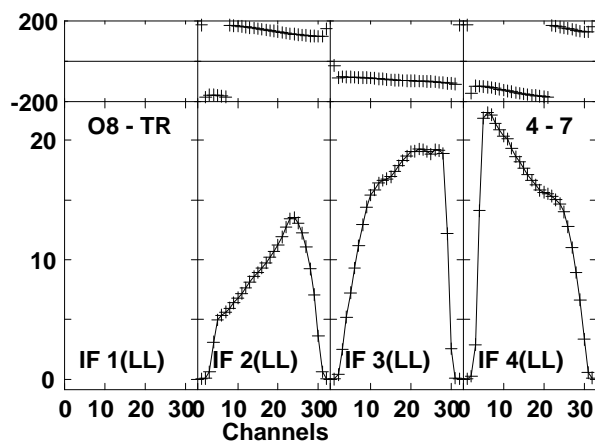
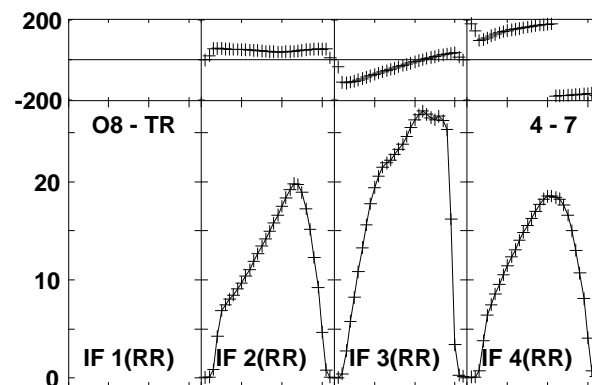
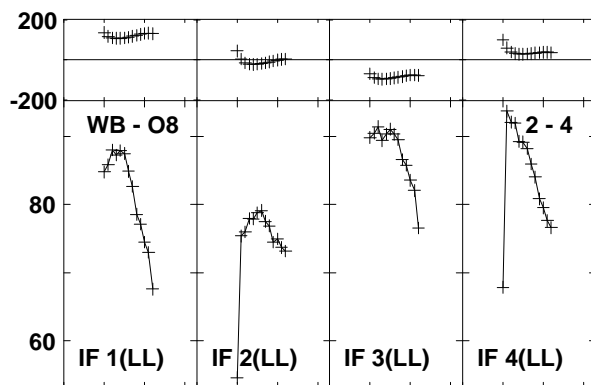
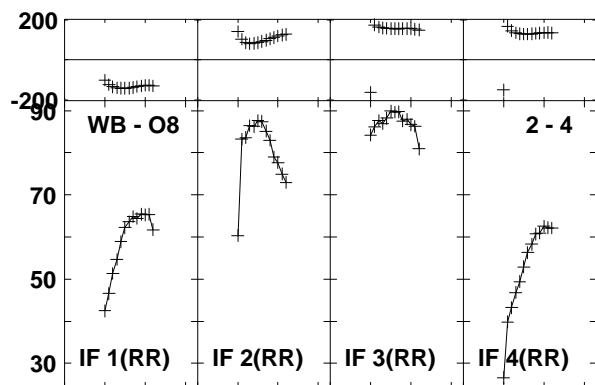
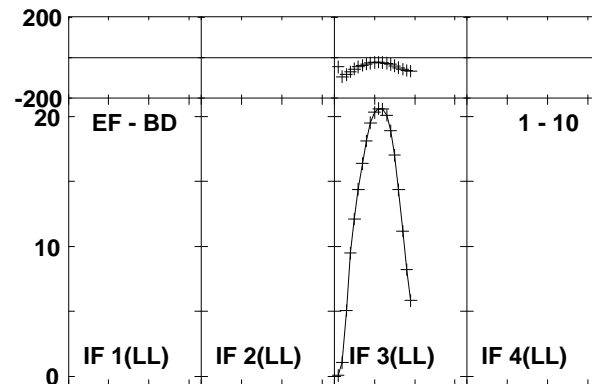
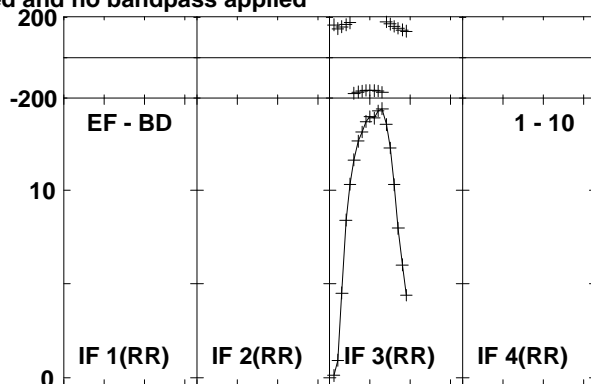
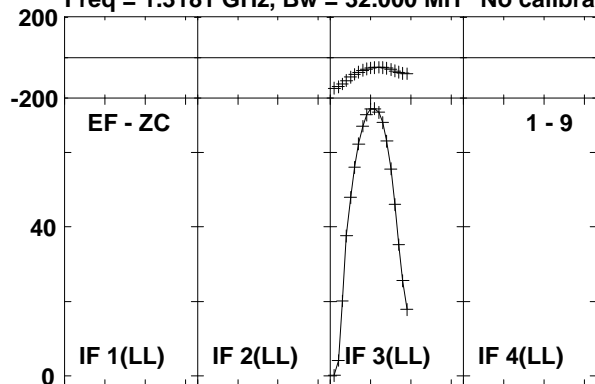

Lower frame: Milli Ampl Jy Top frame: Phas deg
 Vector averaged cross-power spectrum Baseline: EF (01) - ZC (09)
 Timerange: 00/05:11:03 to 00/05:20:59

Plot file version 48 created 20-NOV-2015 13:43:52
 3C84 EO013 1.UVDATA.1
 Freq = 1.3181 GHz, Bw = 32.000 MH No calibration applied and no bandpass applied

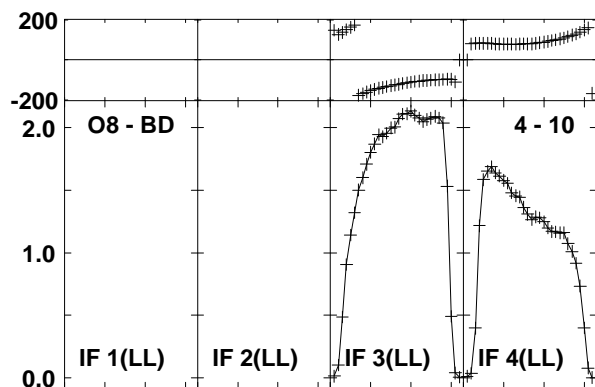
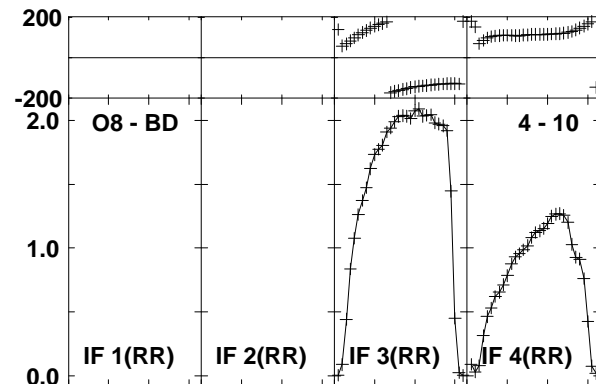
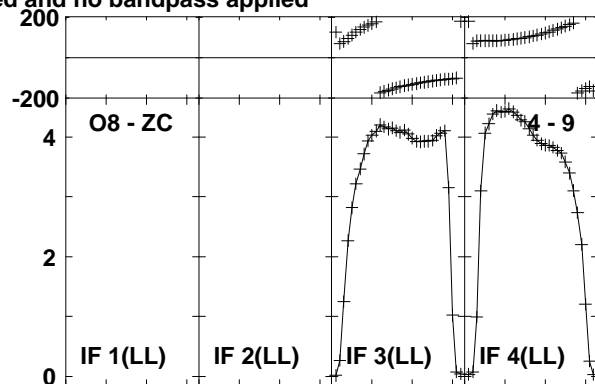
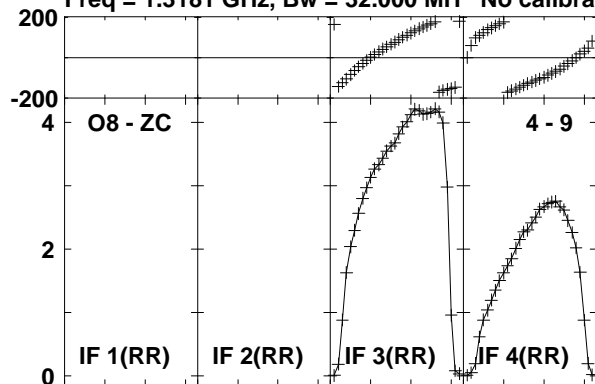

Lower frame: Milli Ampl Jy Top frame: Phas deg
 Vector averaged cross-power spectrum Baseline: O8 (04) - ZC (09)
 Timerange: 00/05:11:03 to 00/05:20:59

Plot file version 49 created 20-NOV-2015 13:43:52

3C84 EO013 1.UVDATA.1

Freq = 1.3181 GHz, Bw = 32.000 MH No calibration applied and no bandpass applied

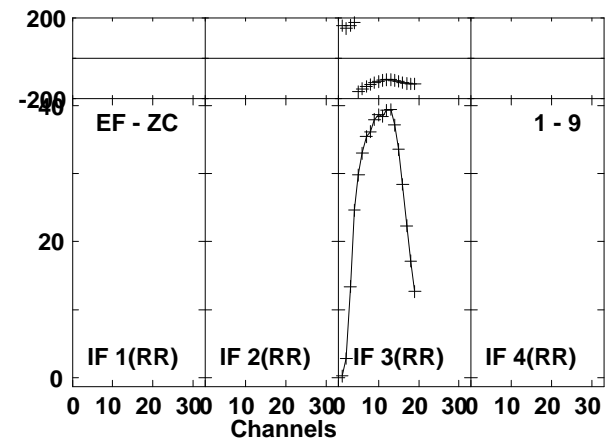
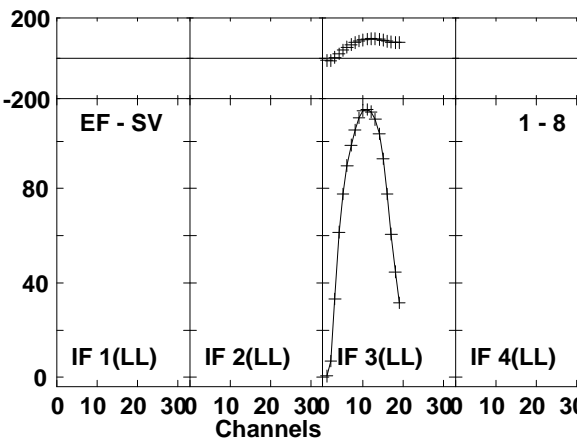
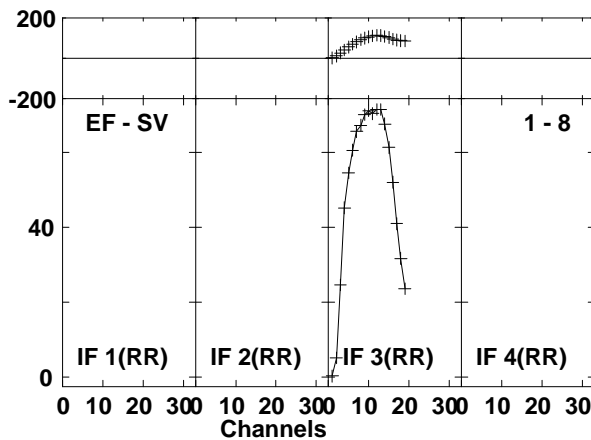
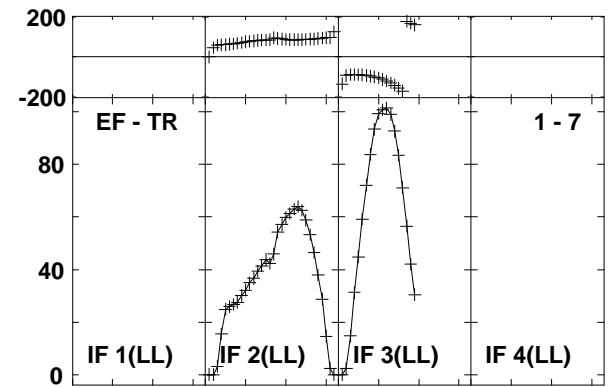
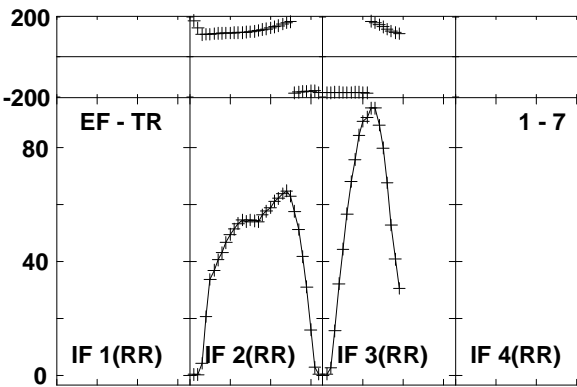
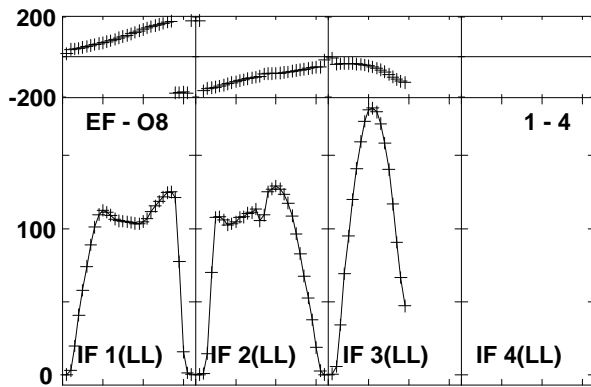
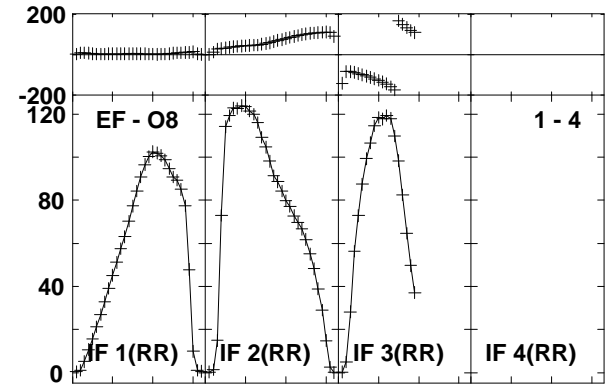
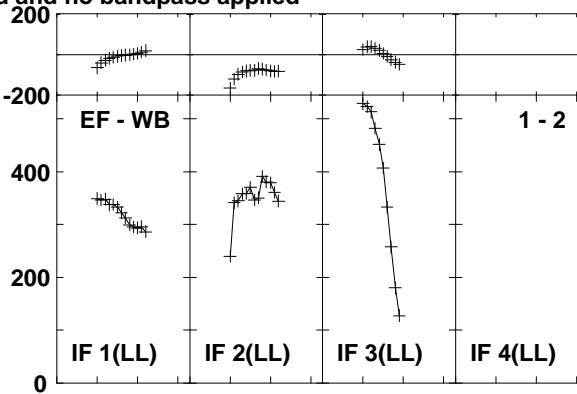
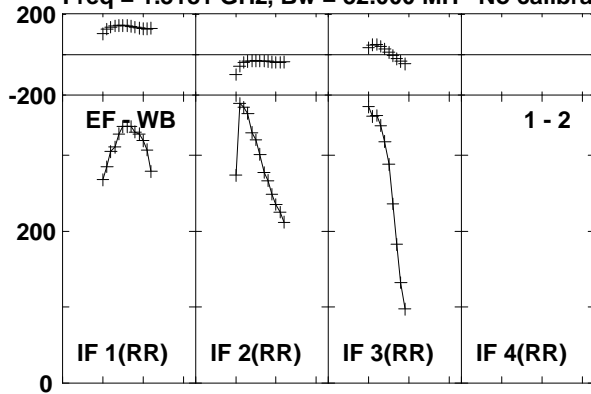

Lower frame: Milli Ampl Jy Top frame: Phas deg
Vector averaged cross-power spectrum Baseline: EF (01) - WB (02)
Timerange: 00/05:21:33 to 00/05:31:29

Plot file version 50 created 20-NOV-2015 13:43:52
 3C84 EO013 1.UVDATA.1
 Freq = 1.3181 GHz, Bw = 32.000 MH No calibration applied and no bandpass applied

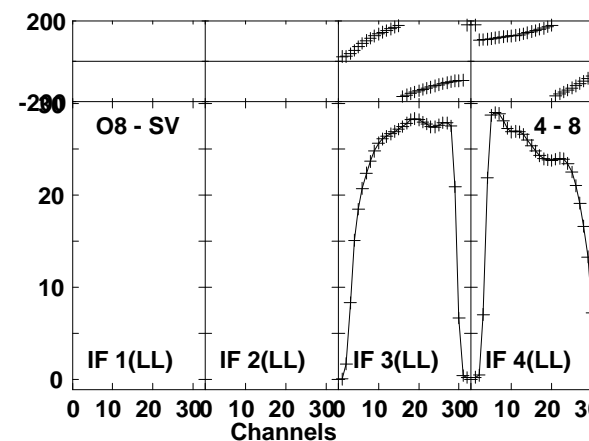
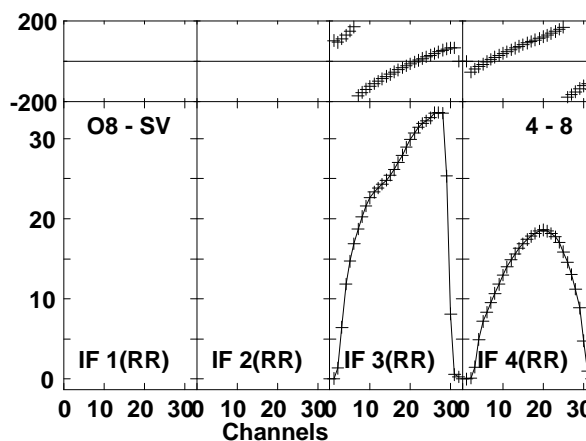
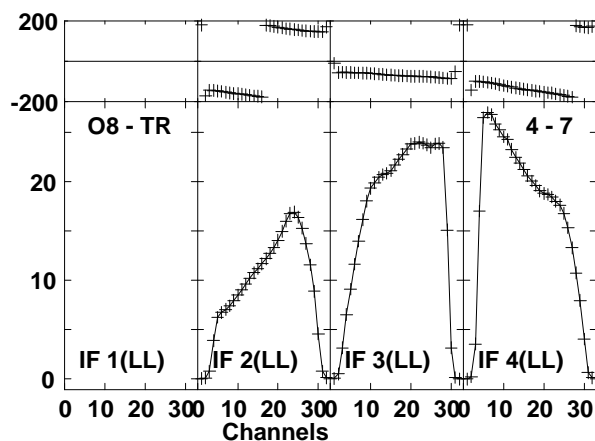
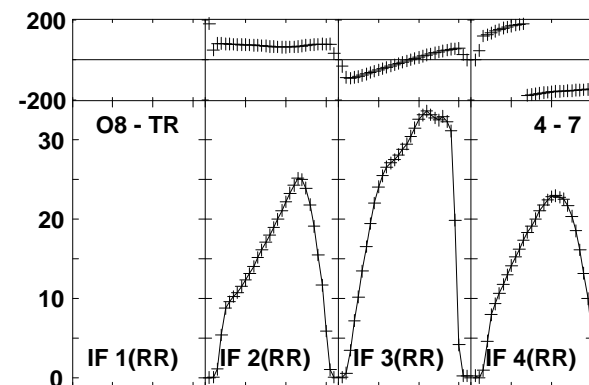
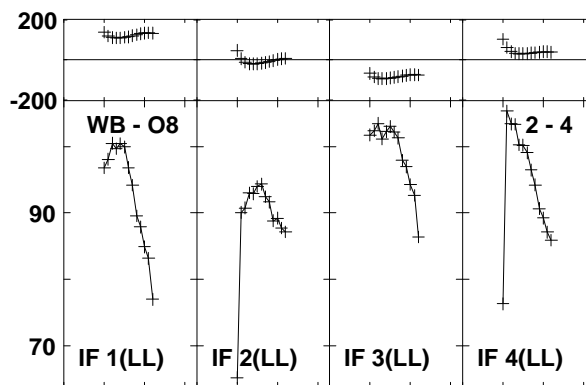
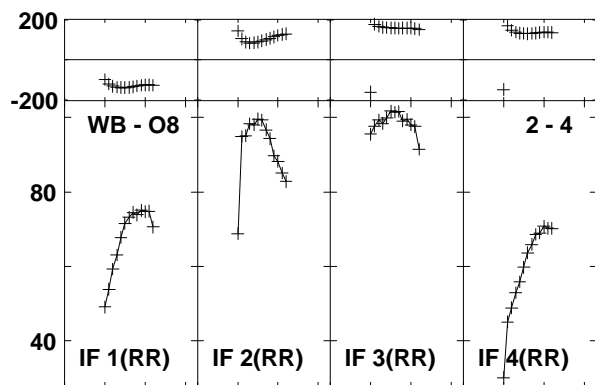
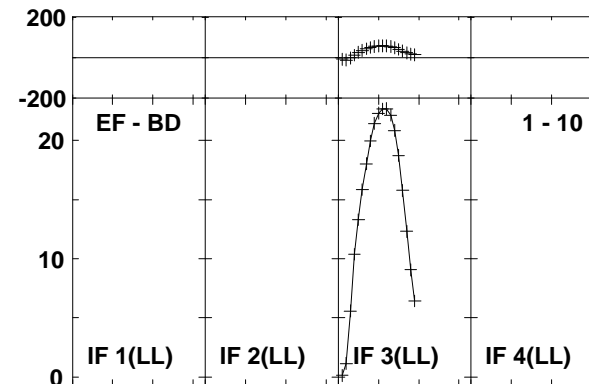
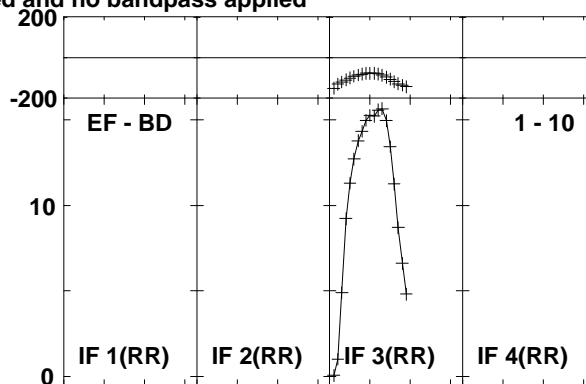
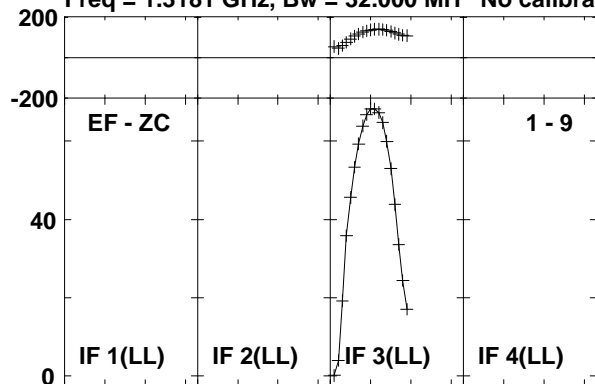

Lower frame: Milli Ampl Jy Top frame: Phas deg
 Vector averaged cross-power spectrum Baseline: EF (01) - ZC (09)
 Timerange: 00/05:21:33 to 00/05:31:29

Plot file version 51 created 20-NOV-2015 13:43:52
 3C84 EO013 1.UVDATA.1
 Freq = 1.3181 GHz, Bw = 32.000 MH No calibration applied and no bandpass applied

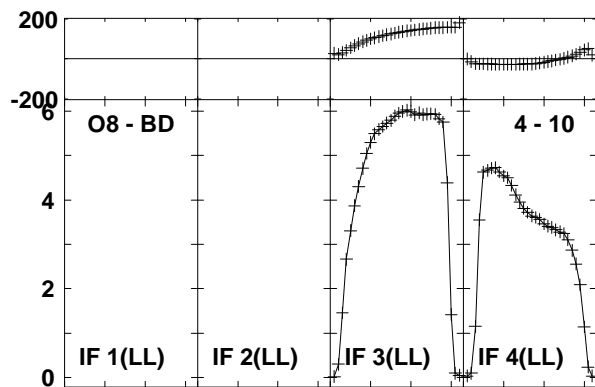
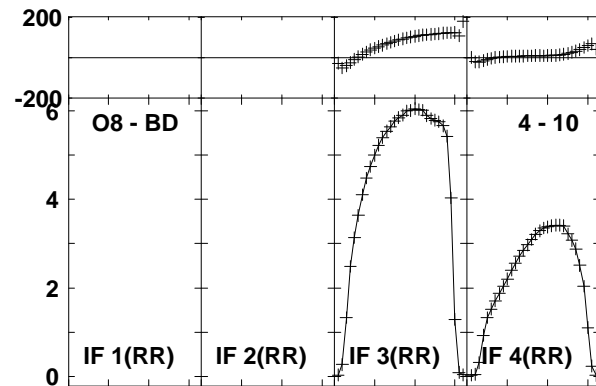
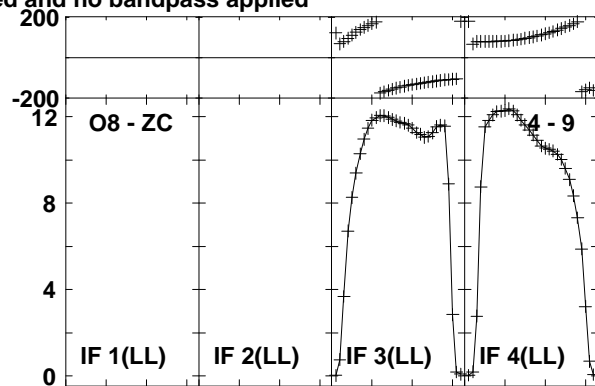
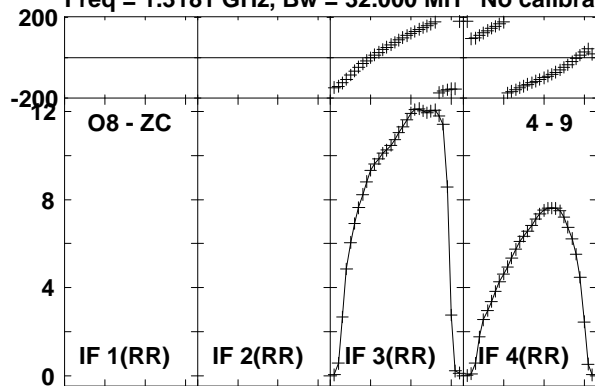

Lower frame: Milli Ampl Jy Top frame: Phas deg
 Vector averaged cross-power spectrum Baseline: O8 (04) - ZC (09)
 Timerange: 00/05:21:33 to 00/05:31:29

Plot file version 52 created 20-NOV-2015 13:43:52
 3C84 EO013 1.UVDATA.1
 Freq = 1.3181 GHz, Bw = 32.000 MH No calibration applied and no bandpass applied

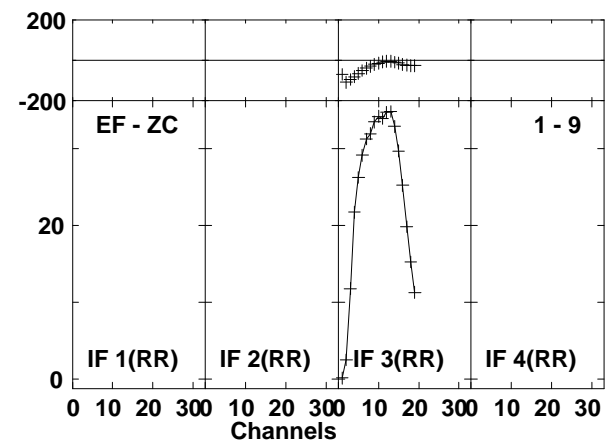
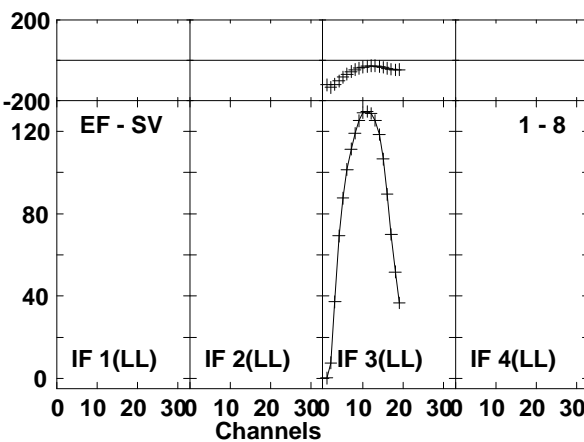
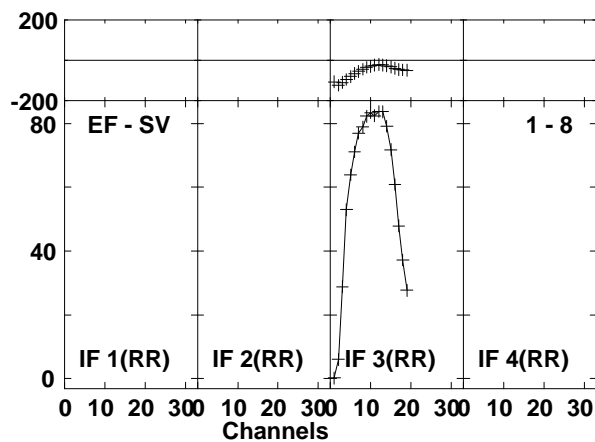
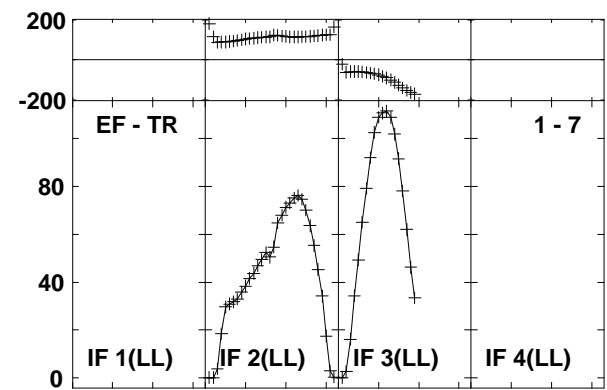
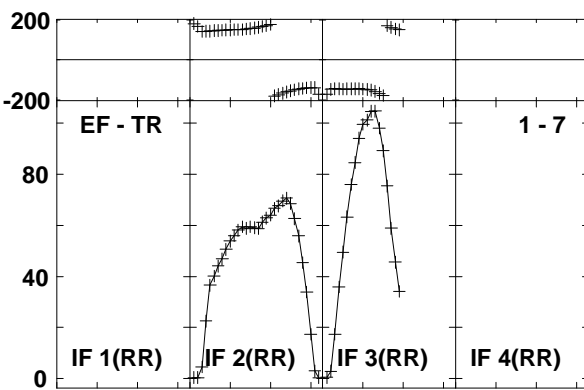
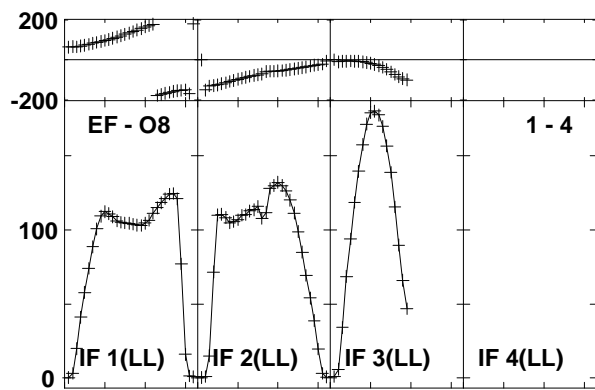
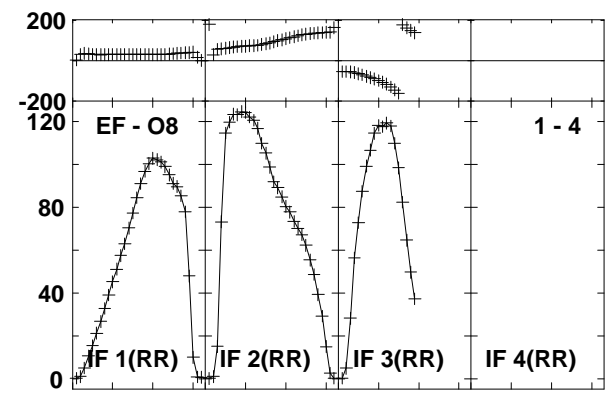
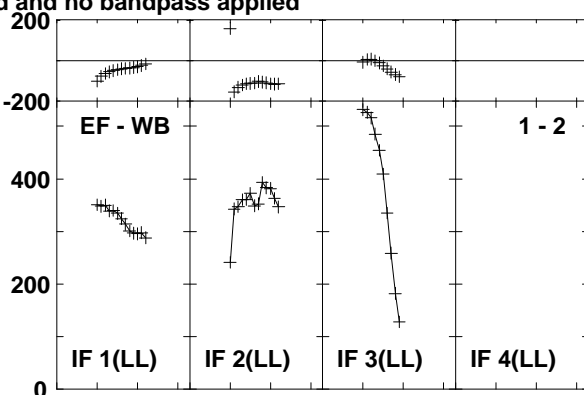
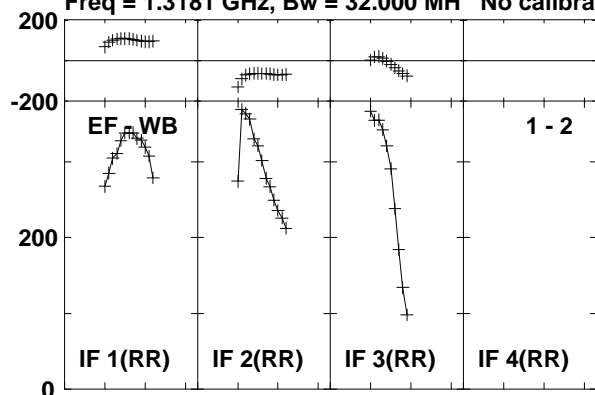

Lower frame: Milli Ampl Jy Top frame: Phas deg
 Vector averaged cross-power spectrum Baseline: EF (01) - WB (02)
 Timerange: 00/05:32:03 to 00/05:41:59

Plot file version 53 created 20-NOV-2015 13:43:52
 3C84 EO013 1.UVDATA.1
 Freq = 1.3181 GHz, Bw = 32.000 MH No calibration applied and no bandpass applied

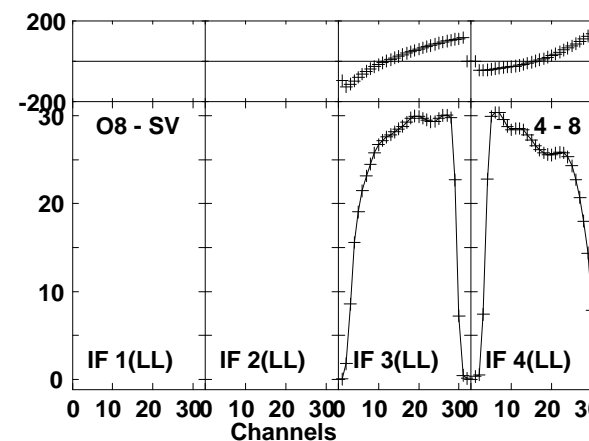
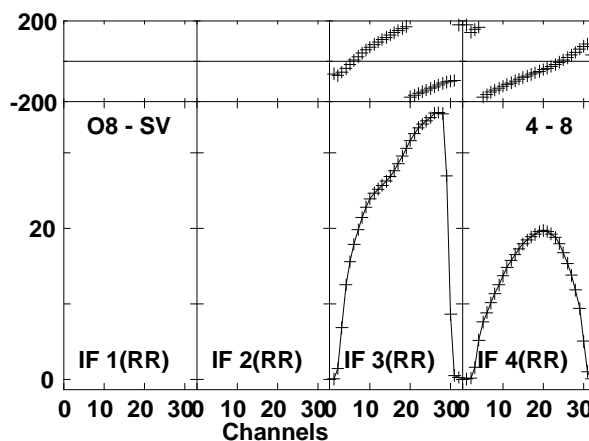
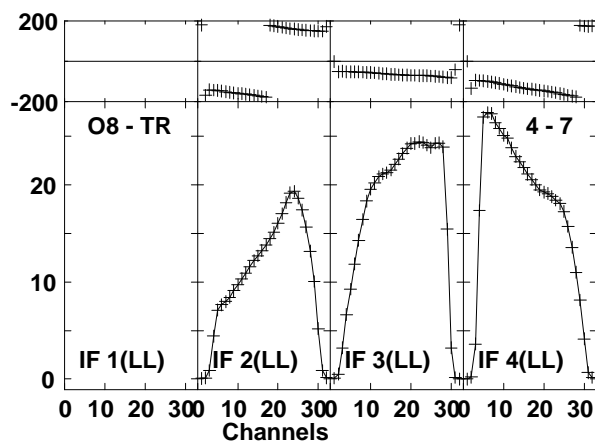
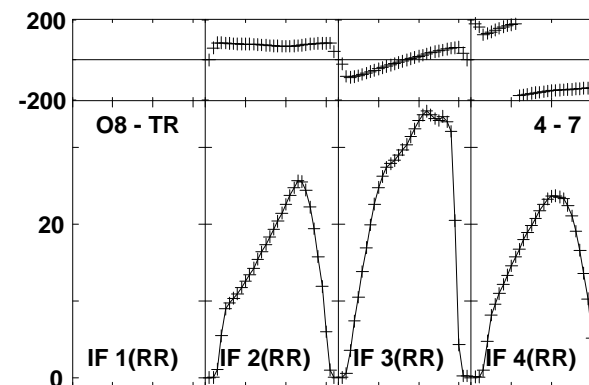
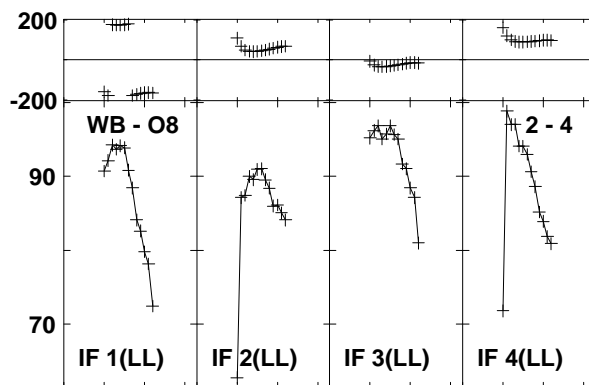
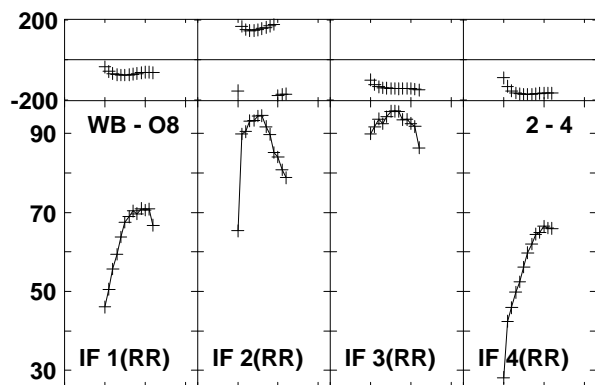
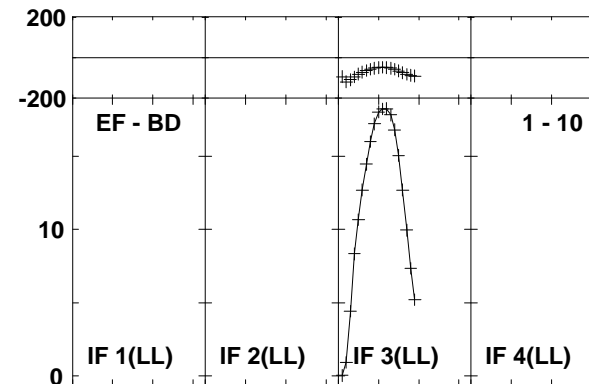
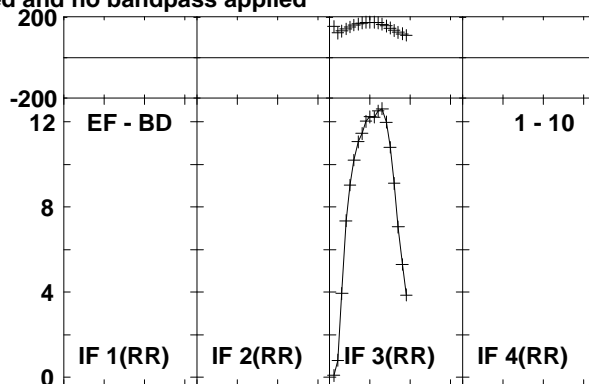
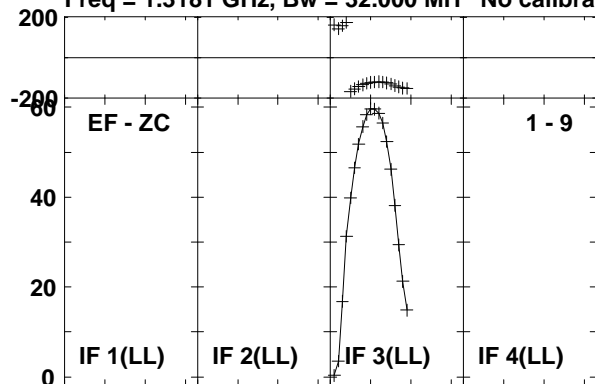

Lower frame: Milli Ampl Jy Top frame: Phas deg
 Vector averaged cross-power spectrum Baseline: EF (01) - ZC (09)
 Timerange: 00/05:32:03 to 00/05:41:59

Plot file version 54 created 20-NOV-2015 13:43:53

3C84 EO013 1.UVDATA.1

Freq = 1.3181 GHz, Bw = 32.000 MH No calibration applied and no bandpass applied

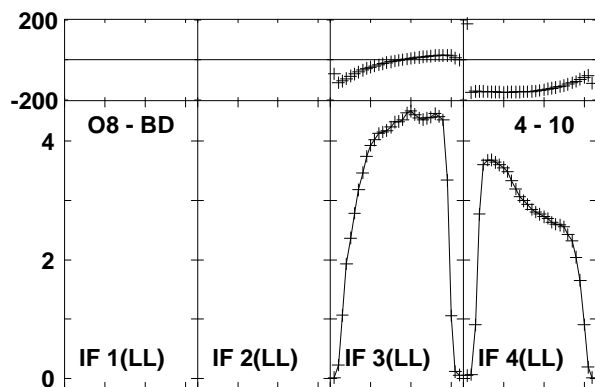
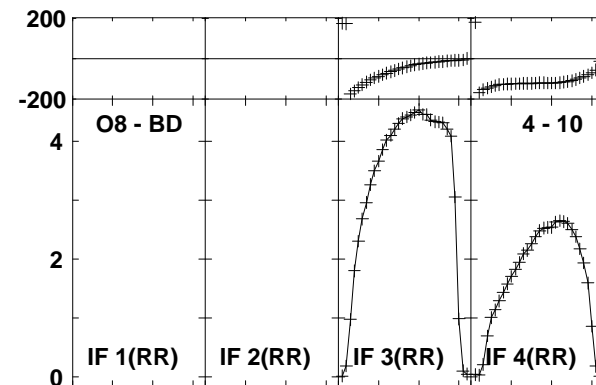
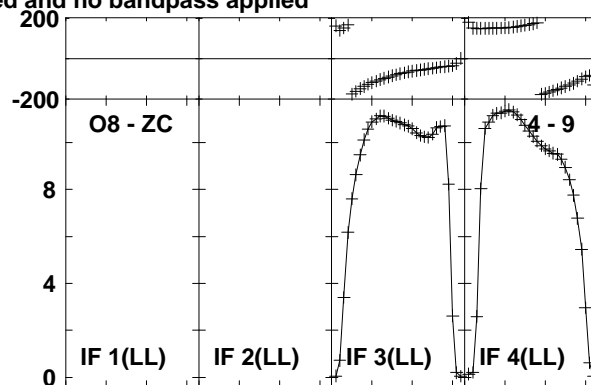
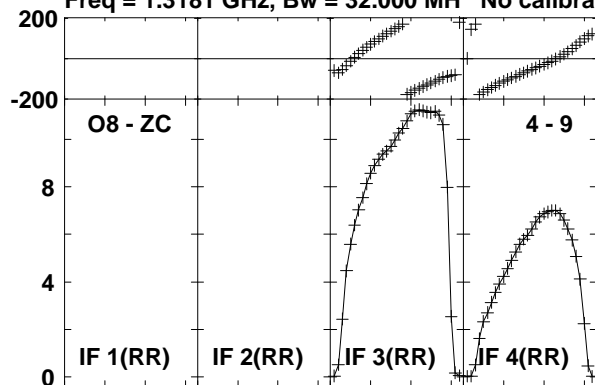

Lower frame: Milli Ampl Jy Top frame: Phas deg
Vector averaged cross-power spectrum Baseline: O8 (04) - ZC (09)
Timerange: 00/05:32:03 to 00/05:41:59

Plot file version 55 created 20-NOV-2015 13:43:53

3C84 EO013 1.UVDATA.1

Freq = 1.3181 GHz, Bw = 32.000 MH No calibration applied and no bandpass applied

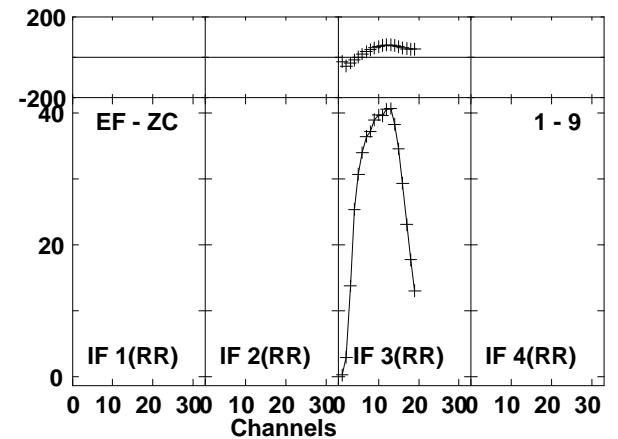
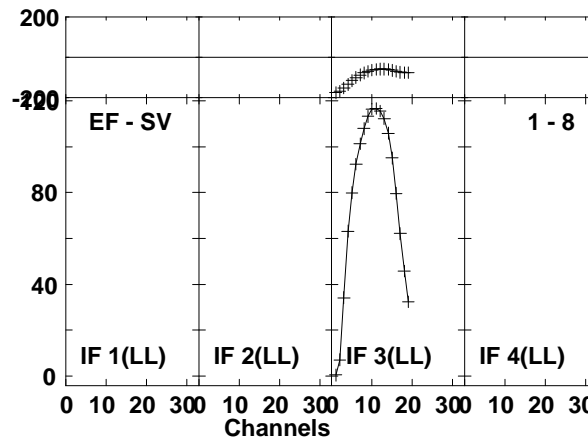
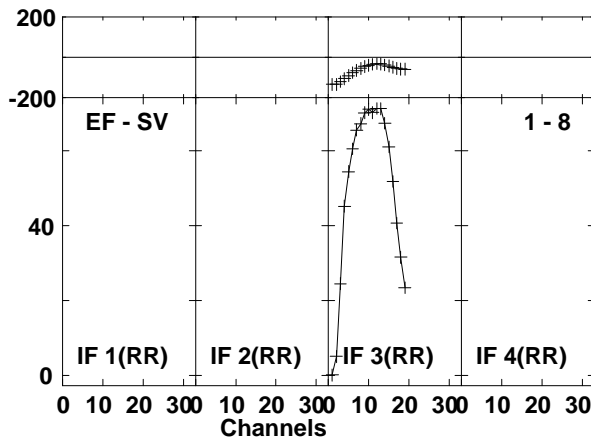
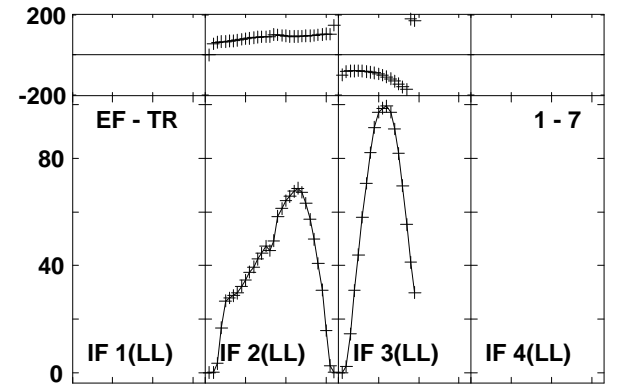
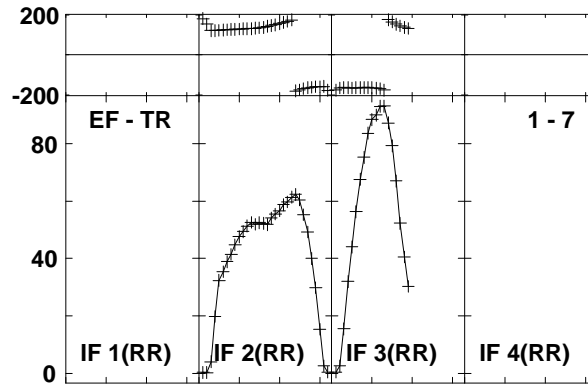
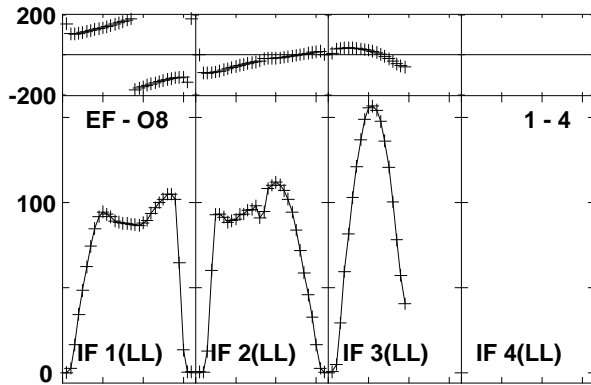
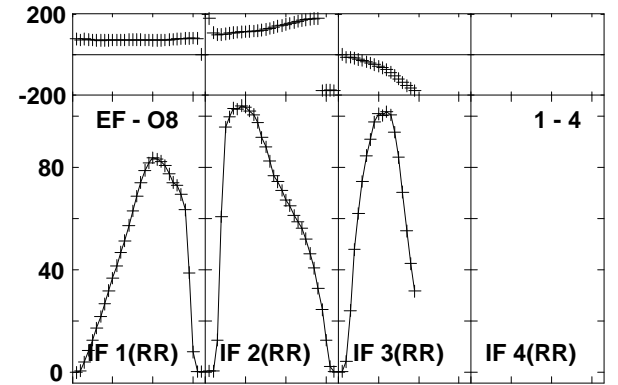
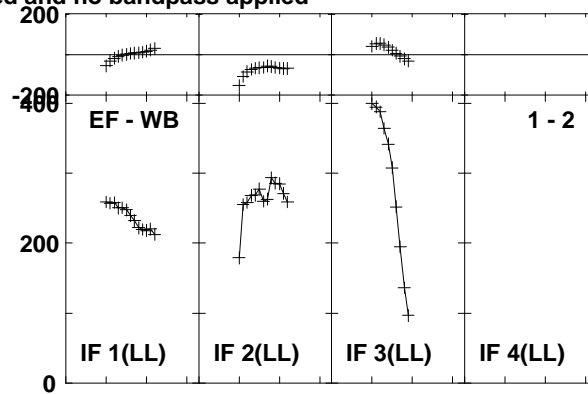
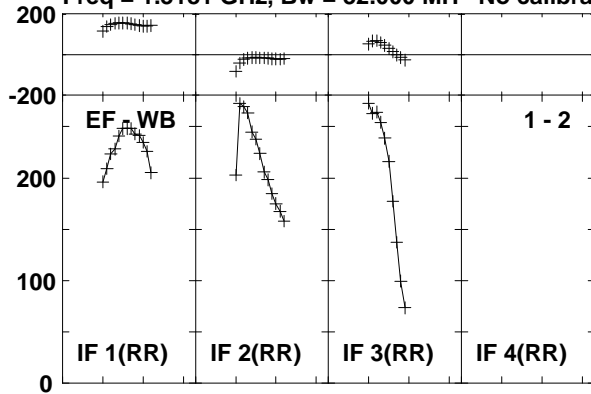

Lower frame: Milli Ampl Jy Top frame: Phas deg
Vector averaged cross-power spectrum Baseline: EF (01) - WB (02)
Timerange: 00/05:42:33 to 00/05:52:29

Plot file version 56 created 20-NOV-2015 13:43:53
 3C84 EO013 1.UVDATA.1
 Freq = 1.3181 GHz, Bw = 32.000 MH No calibration applied and no bandpass applied

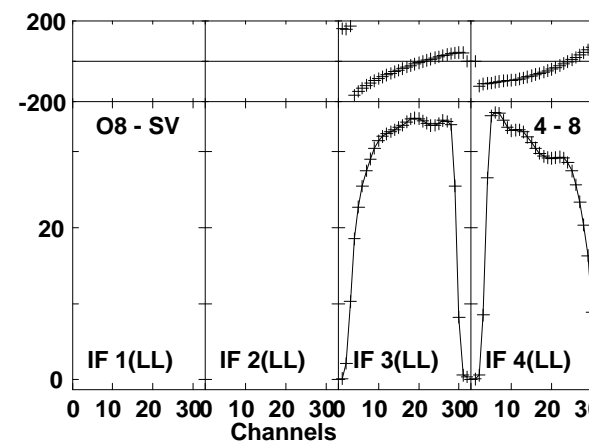
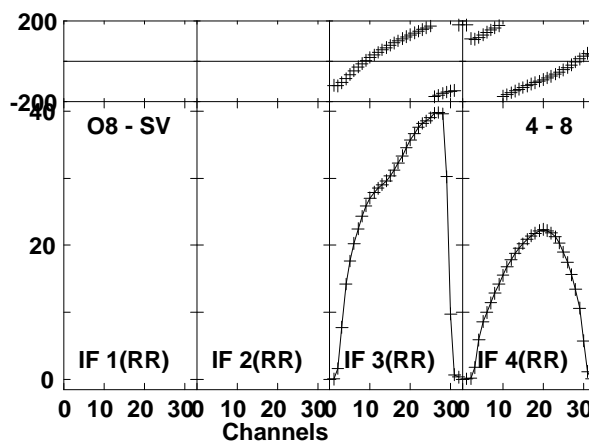
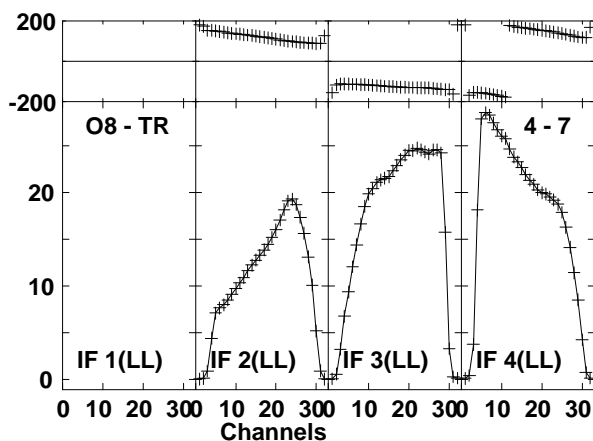
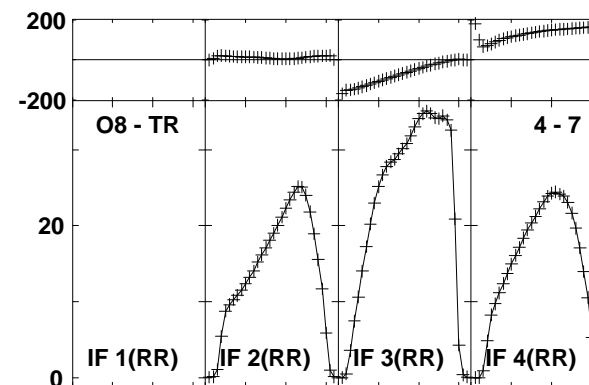
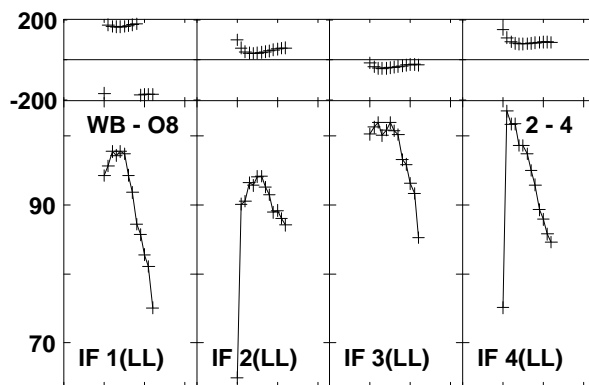
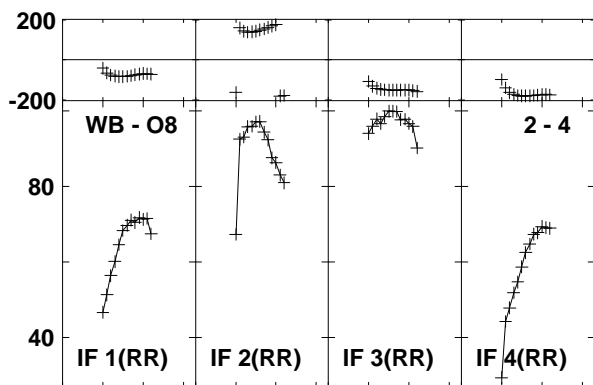
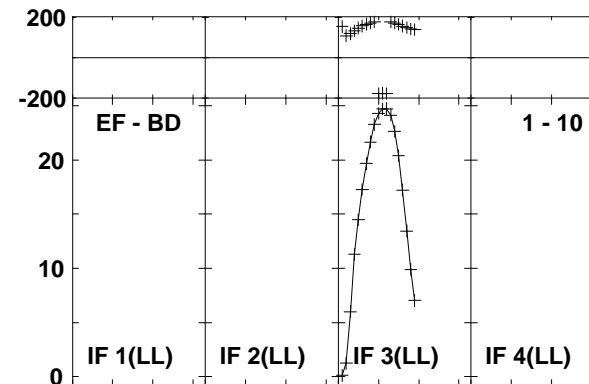
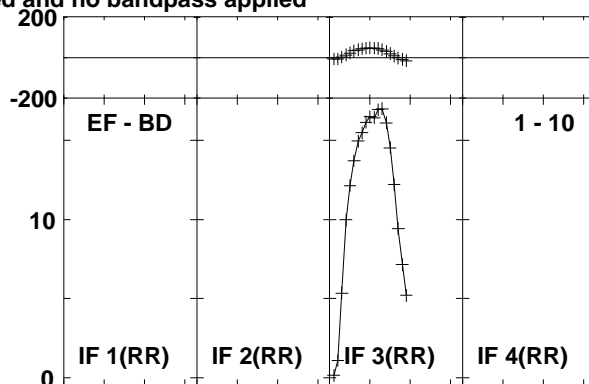
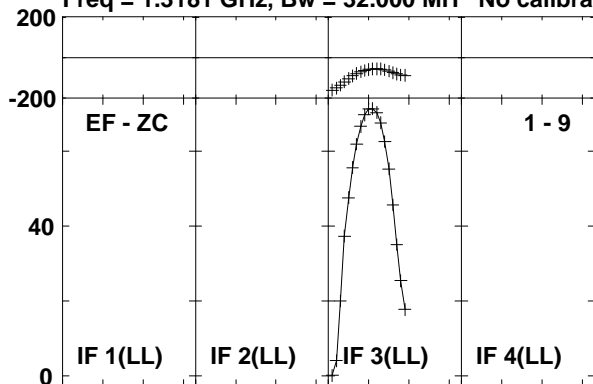

Lower frame: Milli Ampl Jy Top frame: Phas deg
 Vector averaged cross-power spectrum Baseline: EF (01) - ZC (09)
 Timerange: 00/05:42:33 to 00/05:52:29

Plot file version 57 created 20-NOV-2015 13:43:53
 3C84 EO013 1.UVDATA.1
 Freq = 1.3181 GHz, Bw = 32.000 MH No calibration applied and no bandpass applied

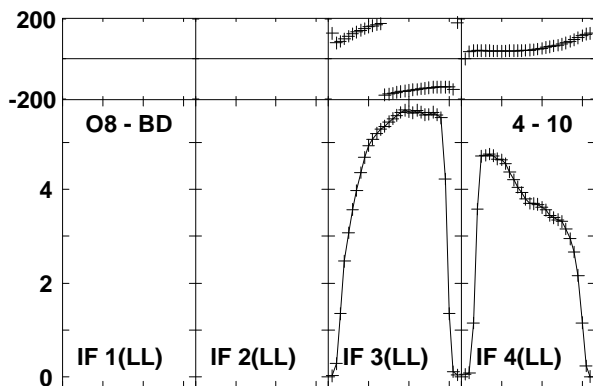
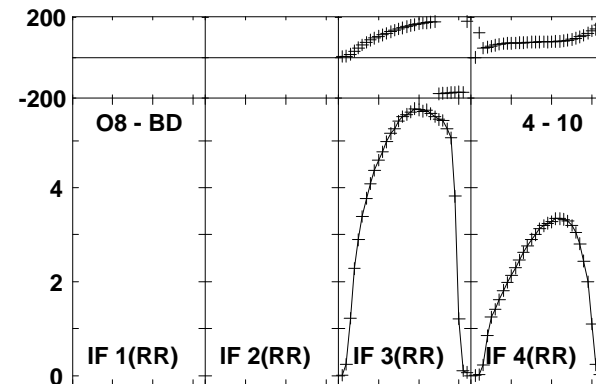
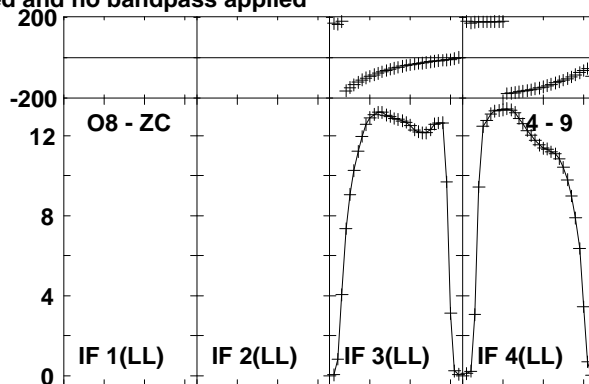
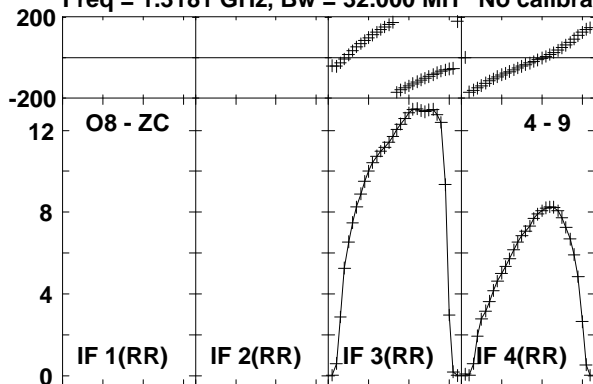

Lower frame: Milli Ampl Jy Top frame: Phas deg
 Vector averaged cross-power spectrum Baseline: O8 (04) - ZC (09)
 Timerange: 00/05:42:33 to 00/05:52:29

Plot file version 58 created 20-NOV-2015 13:43:53
 3C84 EO013 1.UVDATA.1
 Freq = 1.3181 GHz, Bw = 32.000 MH No calibration applied and no bandpass applied

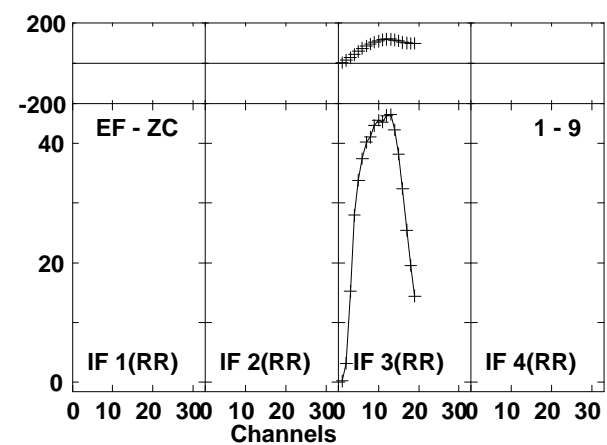
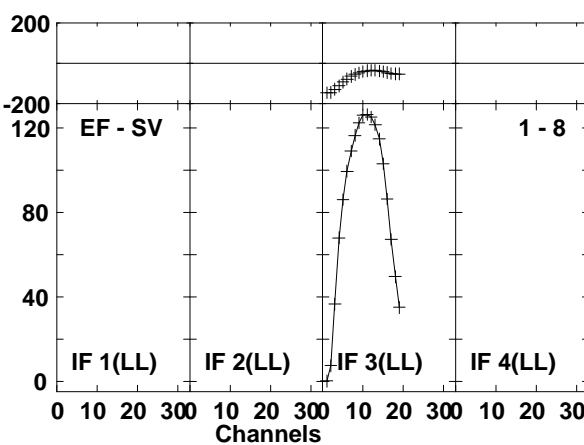
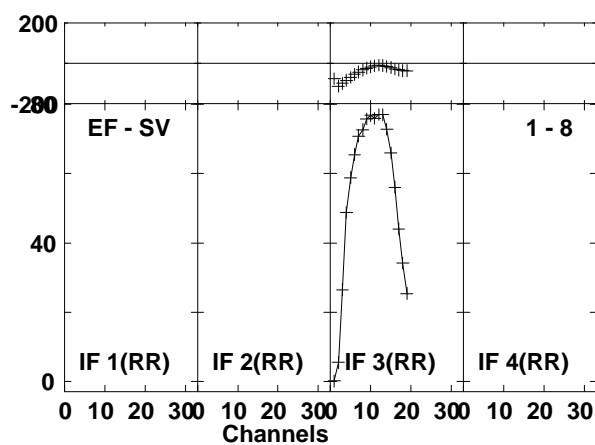
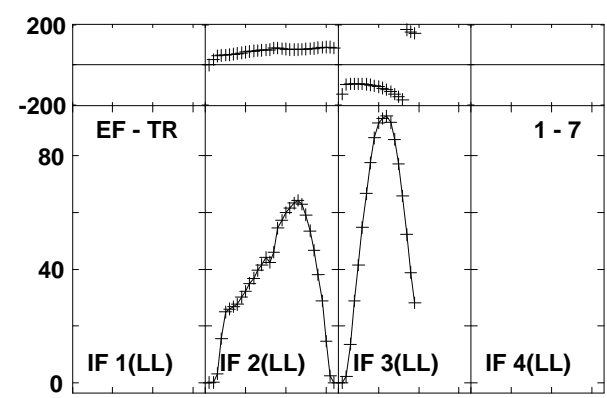
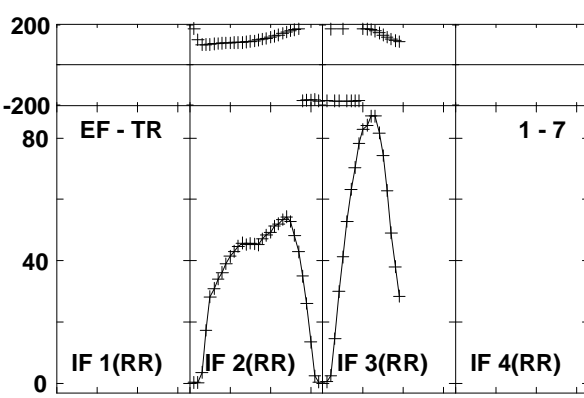
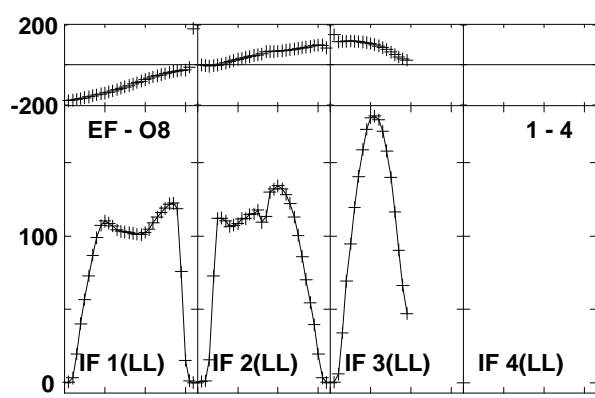
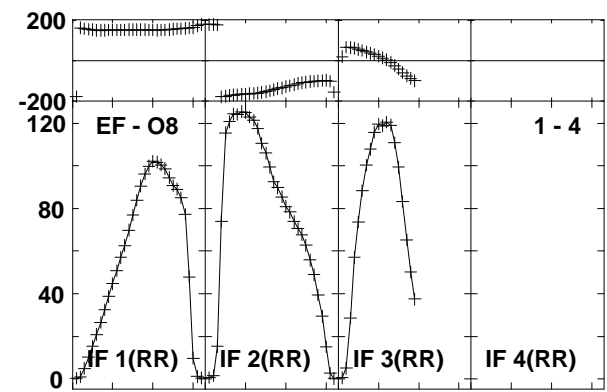
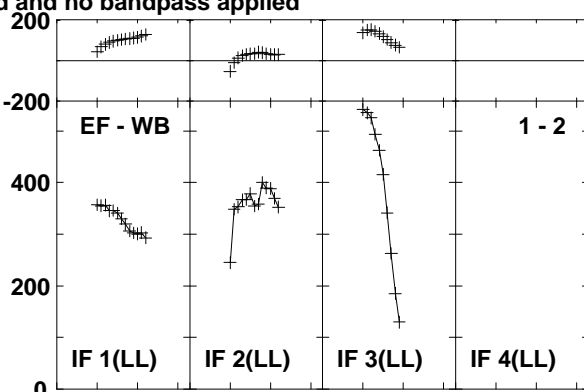
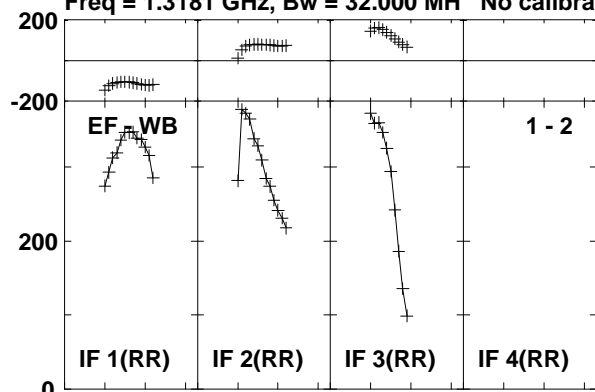

Lower frame: Milli Ampl Jy Top frame: Phas deg
 Vector averaged cross-power spectrum Baseline: EF (01) - WB (02)
 Timerange: 00/05:53:03 to 00/06:02:59

Plot file version 59 created 20-NOV-2015 13:43:53
 3C84 EO013 1.UVDATA.1
 Freq = 1.3181 GHz, Bw = 32.000 MH No calibration applied and no bandpass applied

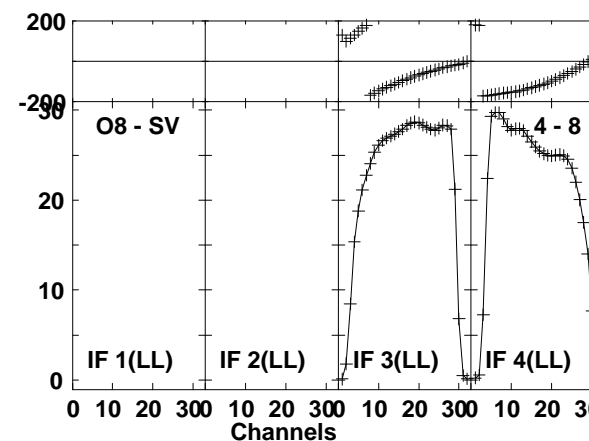
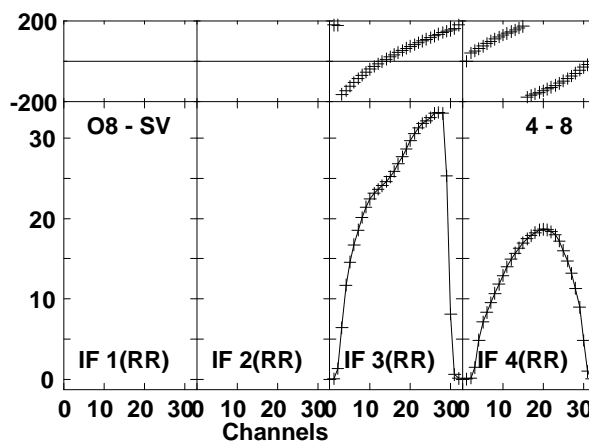
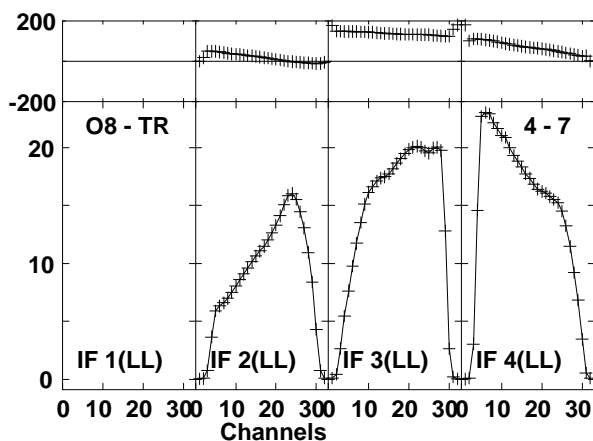
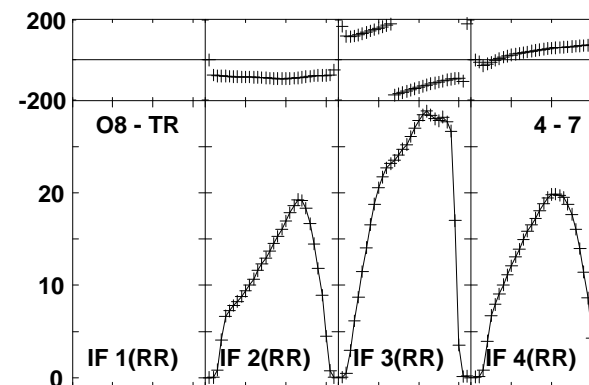
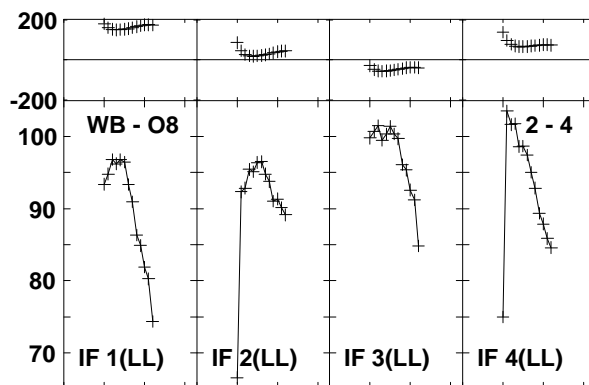
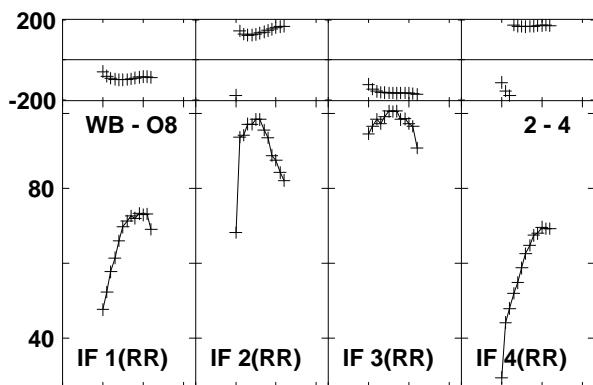
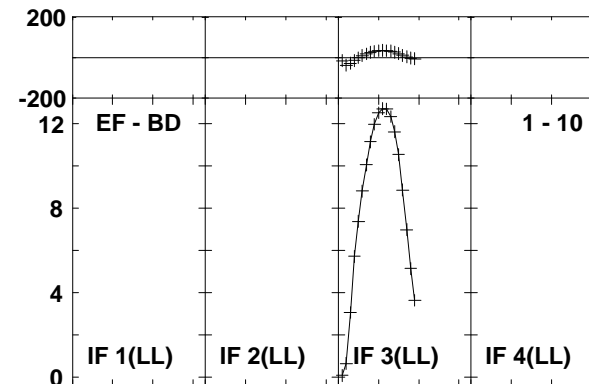
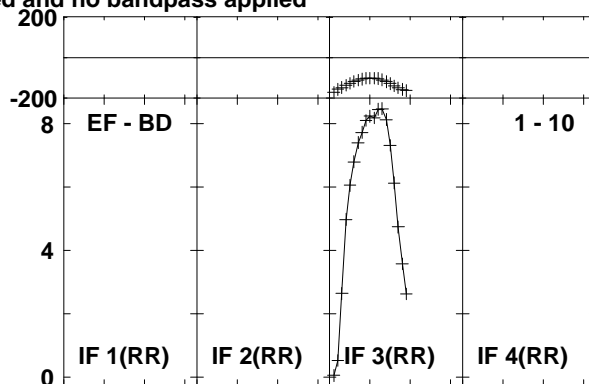
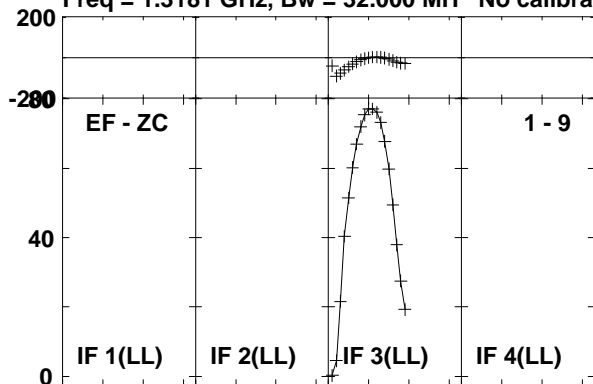

Lower frame: Milli Ampl Jy Top frame: Phas deg
 Vector averaged cross-power spectrum Baseline: EF (01) - ZC (09)
 Timerange: 00/05:53:03 to 00/06:02:59

Plot file version 60 created 20-NOV-2015 13:43:53
 3C84 EO013 1.UVDATA.1
 Freq = 1.3181 GHz, Bw = 32.000 MH No calibration applied and no bandpass applied

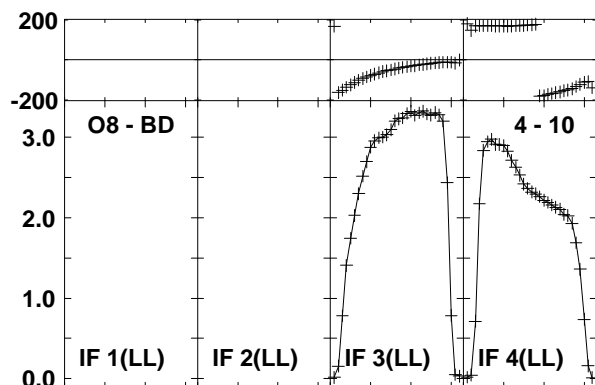
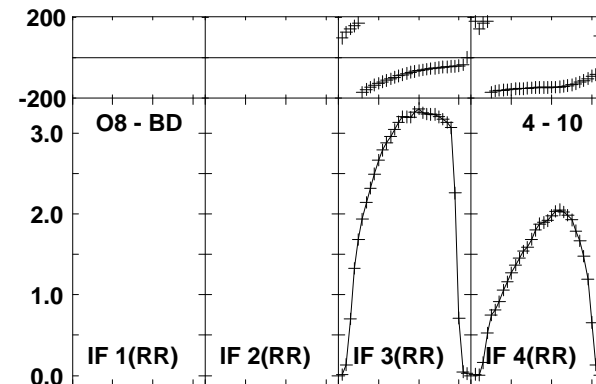
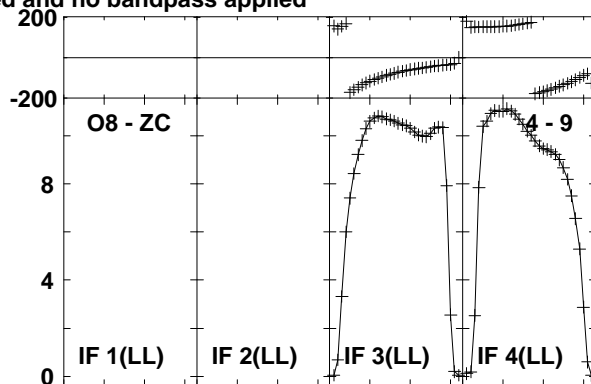
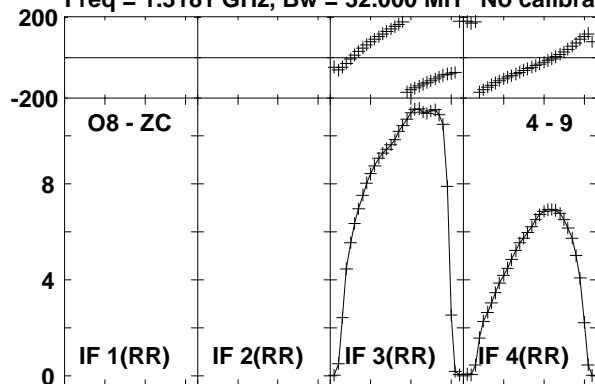

Lower frame: Milli Ampl Jy Top frame: Phas deg
 Vector averaged cross-power spectrum Baseline: O8 (04) - ZC (09)
 Timerange: 00/05:53:03 to 00/06:02:59

Plot file version 61 created 20-NOV-2015 13:43:53

DA193 EO13 1.UVDATA.1

Freq = 1.3181 GHz, Bw = 32.000 MH No calibration applied and no bandpass applied

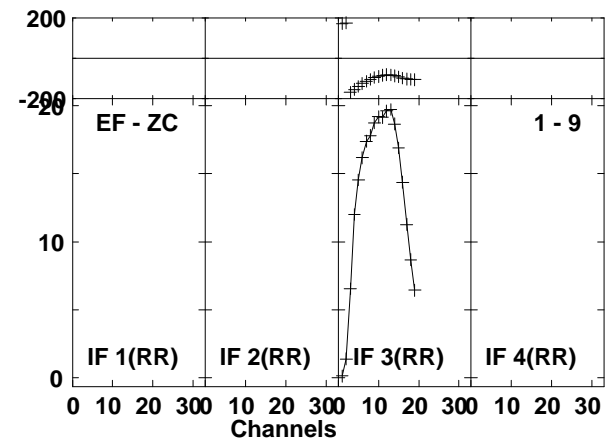
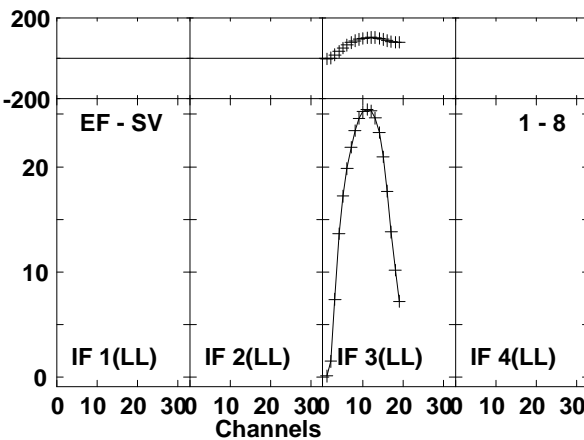
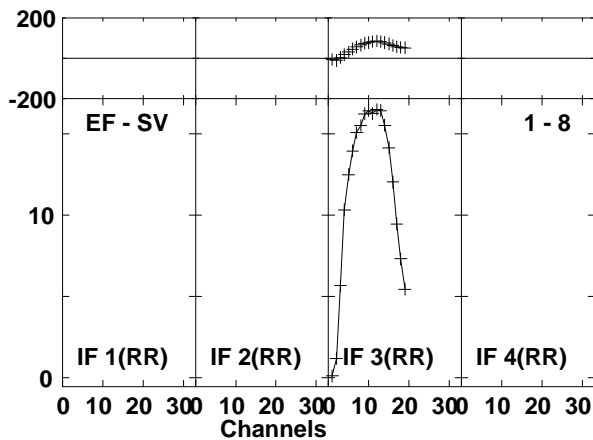
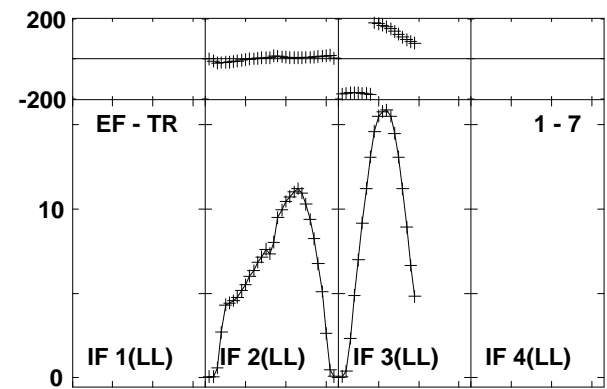
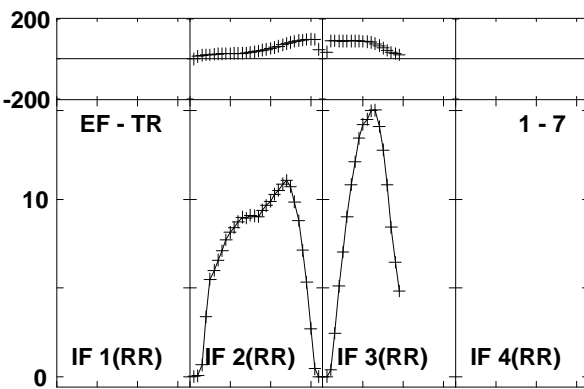
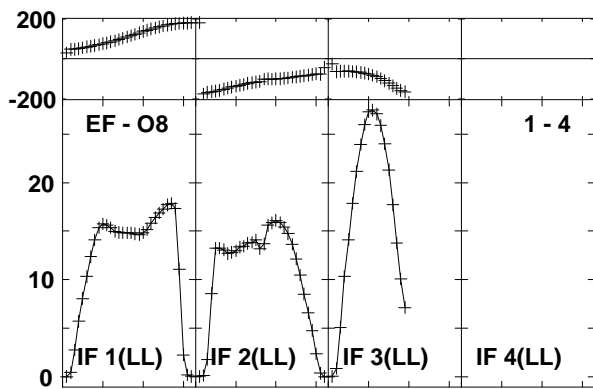
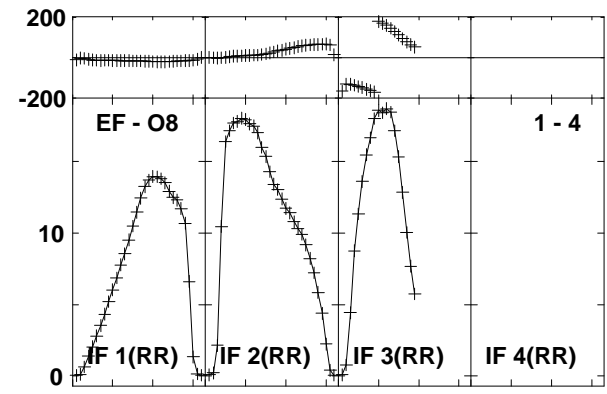
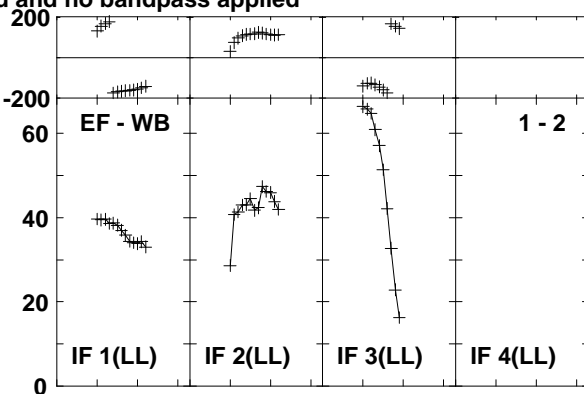
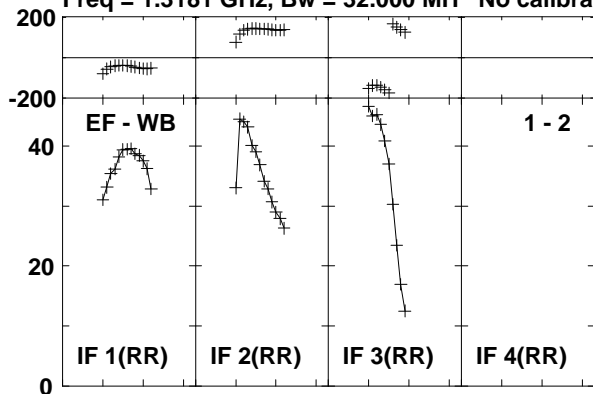

Lower frame: Milli Ampl Jy Top frame: Phas deg
Vector averaged cross-power spectrum Baseline: EF (01) - WB (02)
Timerange: 00/06:06:08 to 00/06:16:04

Plot file version 62 created 20-NOV-2015 13:43:53
 DA193 EO013 1.UVDATA.1
 Freq = 1.3181 GHz, Bw = 32.000 MH No calibration applied and no bandpass applied

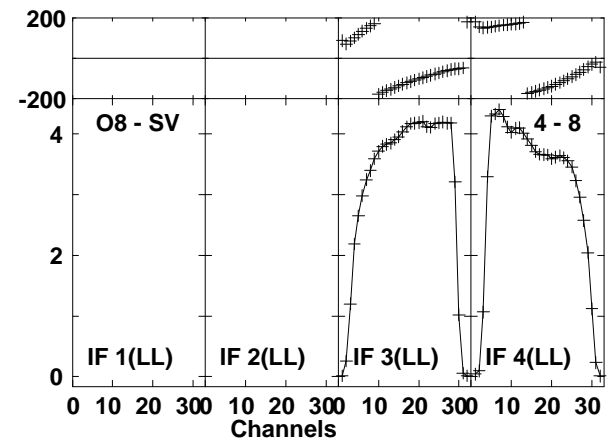
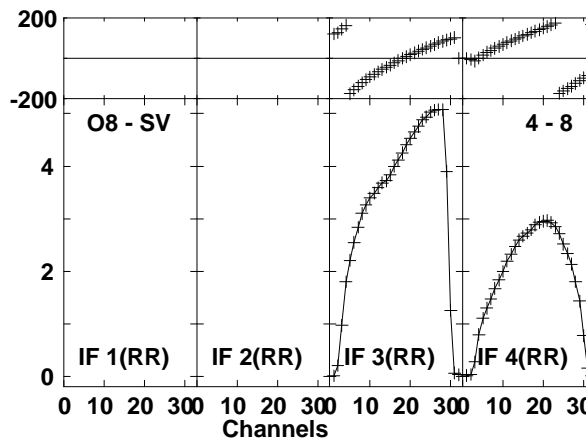
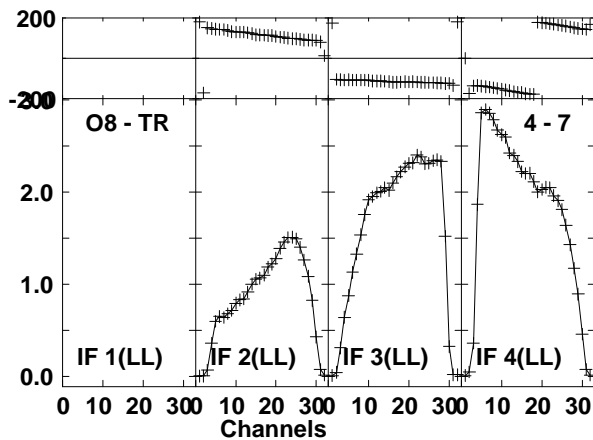
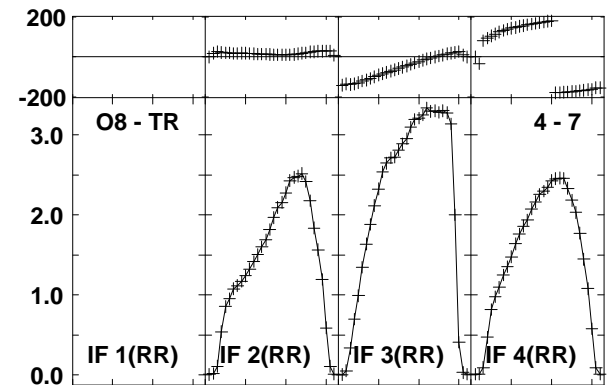
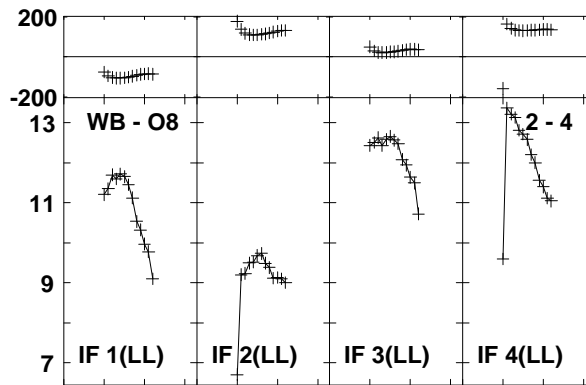
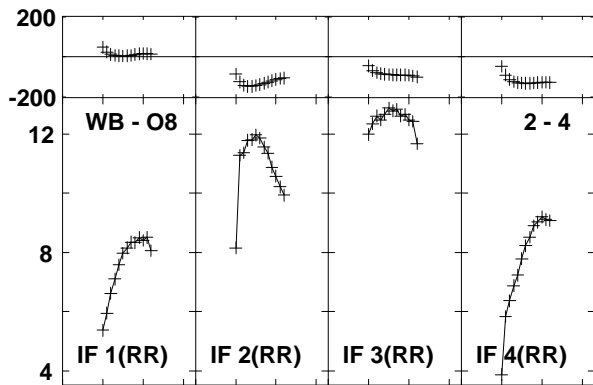
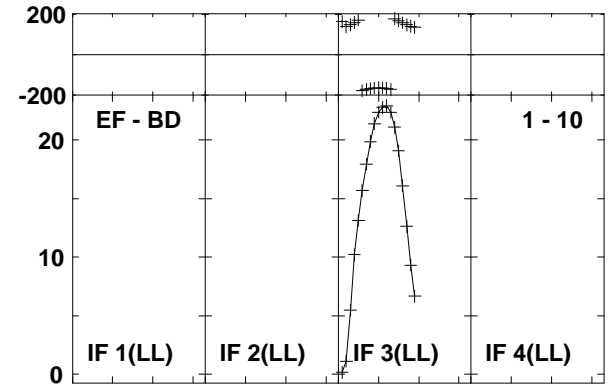
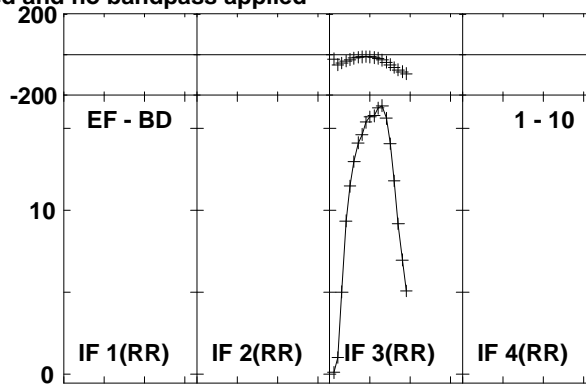
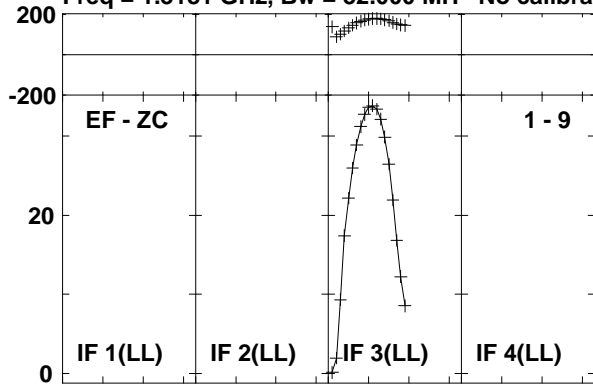

Lower frame: Milli Ampl Jy Top frame: Phas deg
 Vector averaged cross-power spectrum Baseline: EF (01) - ZC (09)
 Timerange: 00/06:06:08 to 00/06:16:04

Plot file version 63 created 20-NOV-2015 13:43:53
 DA193 EO013 1.UVDATA.1
 Freq = 1.3181 GHz, Bw = 32.000 MH No calibration applied and no bandpass applied

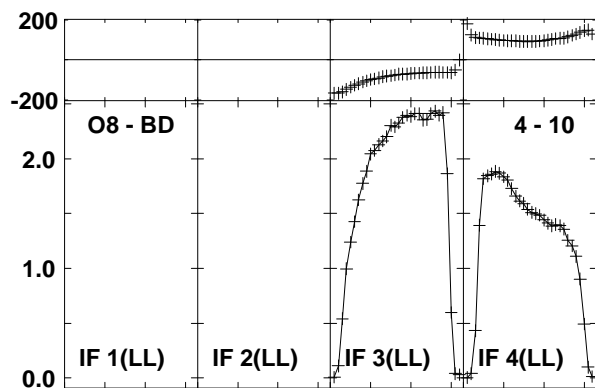
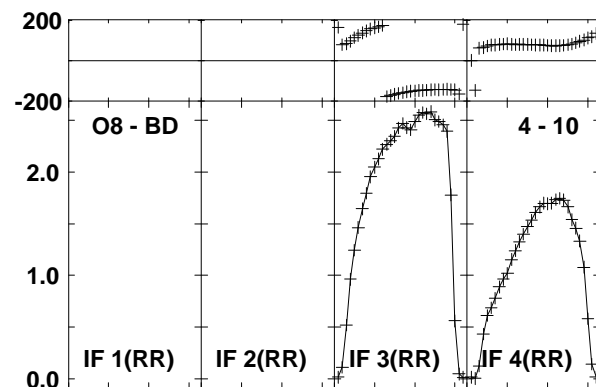
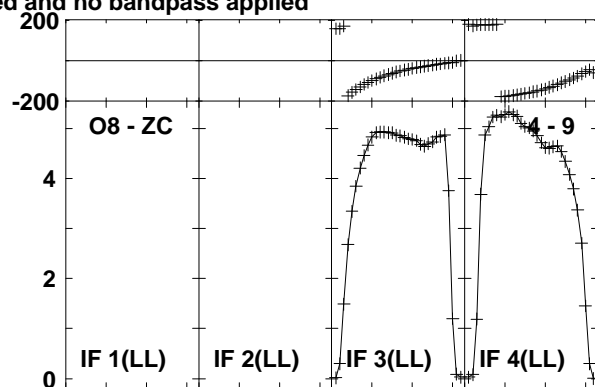
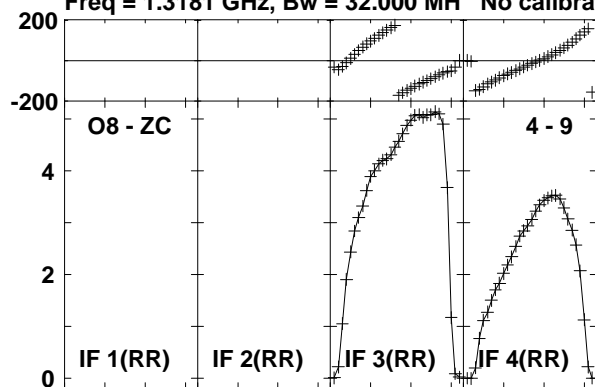

Lower frame: Milli Ampl Jy Top frame: Phas deg
 Vector averaged cross-power spectrum Baseline: O8 (04) - ZC (09)
 Timerange: 00/06:06:08 to 00/06:16:04

Plot file version 64 created 20-NOV-2015 13:43:53

DA193 EO013 1.UVDATA.1

Freq = 1.3181 GHz, Bw = 32.000 MH No calibration applied and no bandpass applied

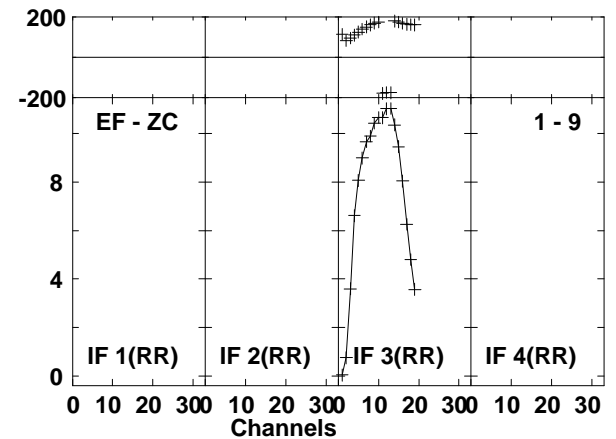
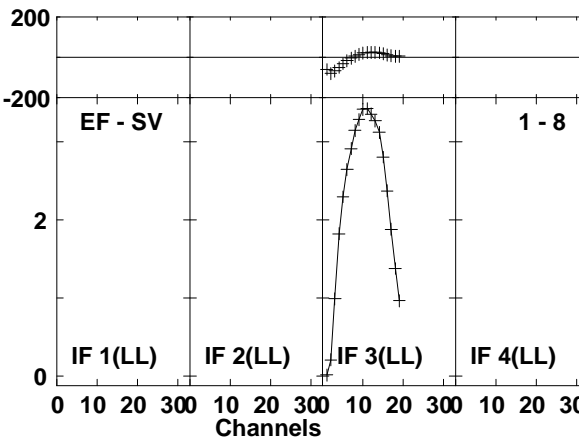
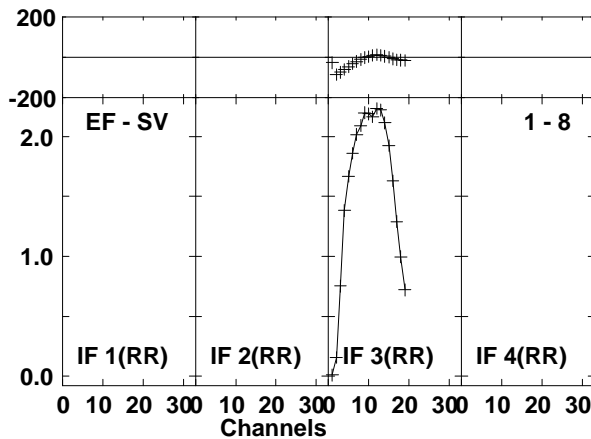
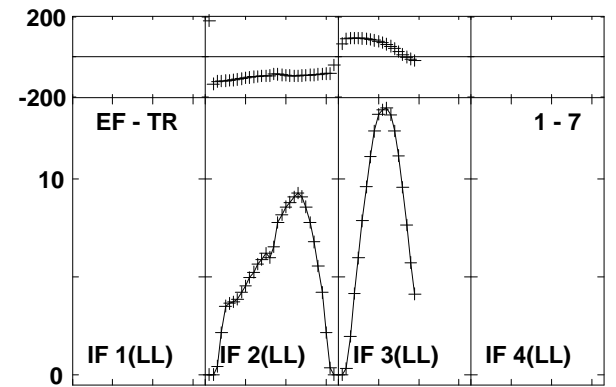
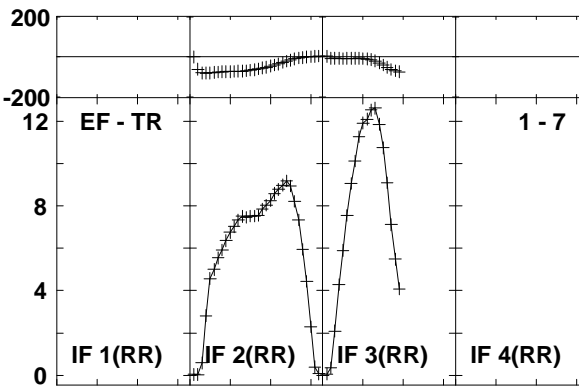
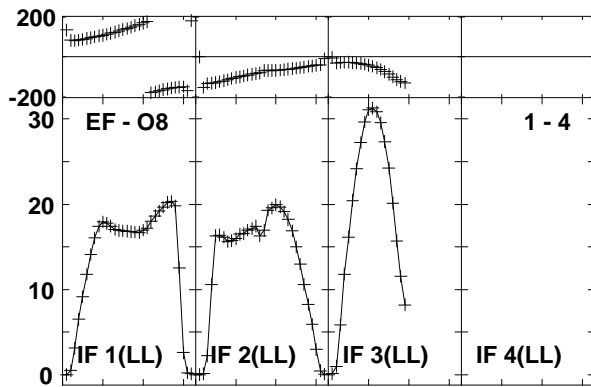
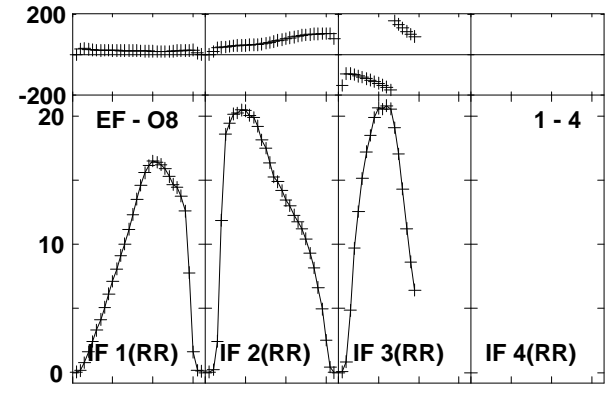
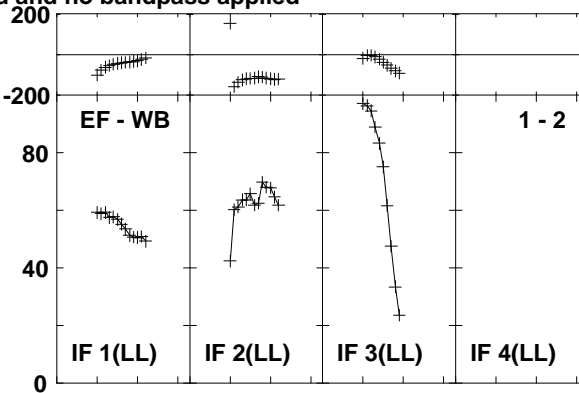
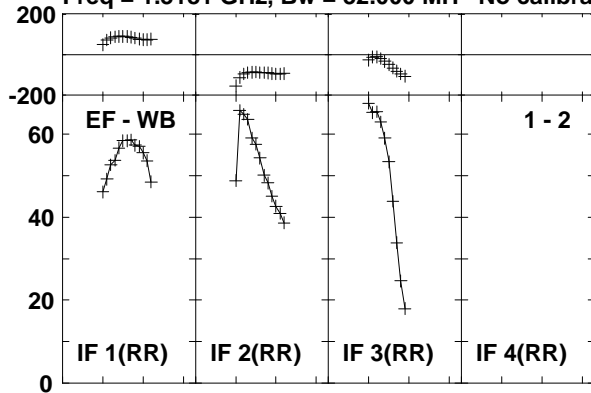

Lower frame: Milli Ampl Jy Top frame: Phas deg
Vector averaged cross-power spectrum Baseline: EF (01) - WB (02)
Timerange: 00/06:16:38 to 00/06:26:34

Plot file version 65 created 20-NOV-2015 13:43:53

DA193 EO013 1.UVDATA.1

Freq = 1.3181 GHz, Bw = 32.000 MH No calibration applied and no bandpass applied

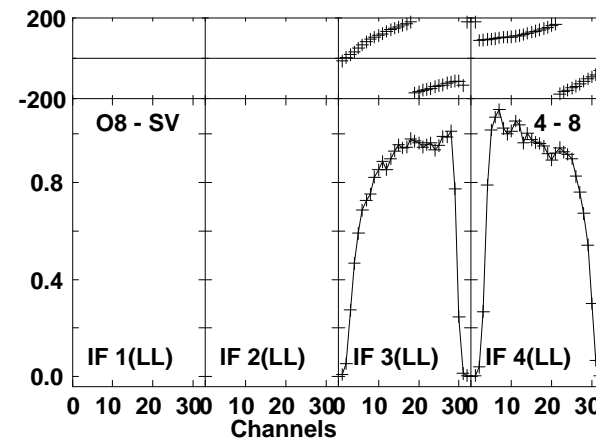
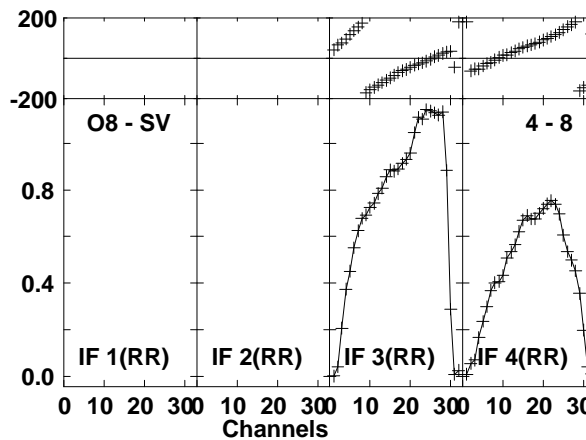
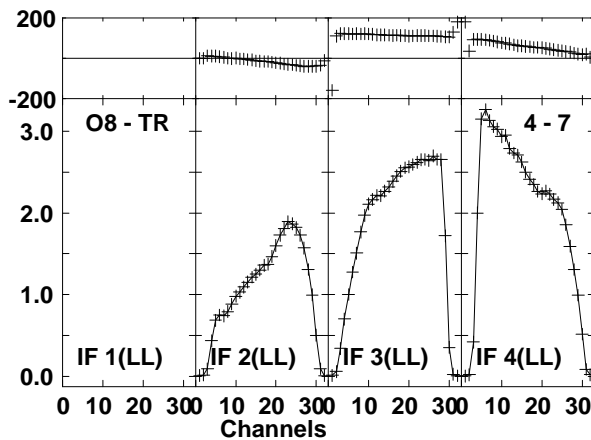
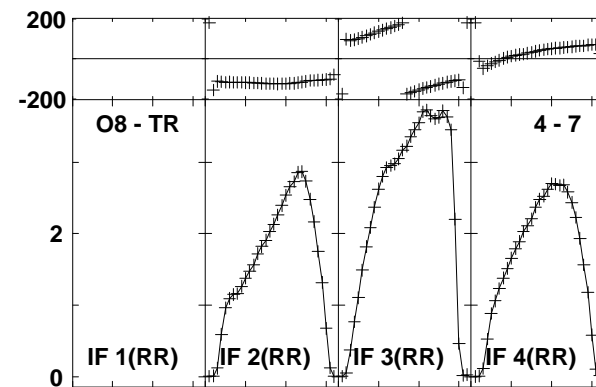
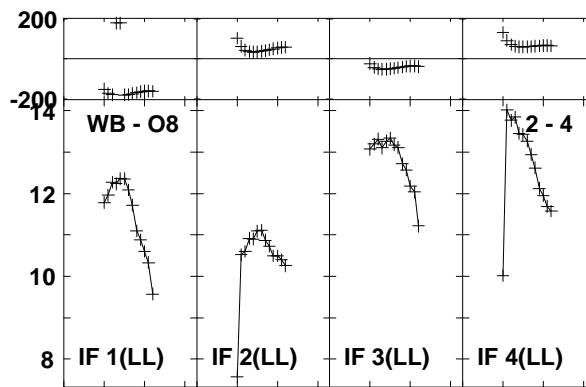
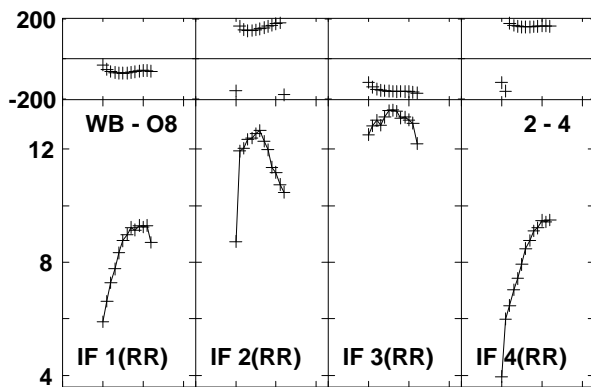
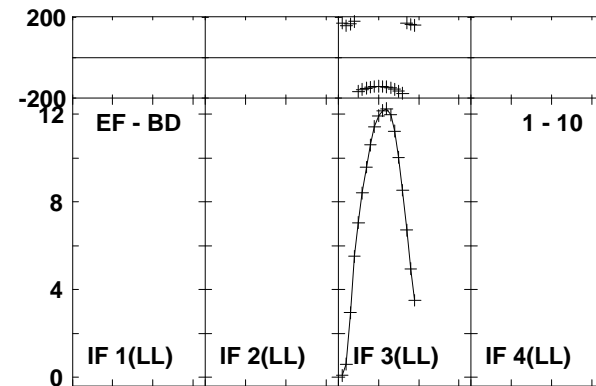
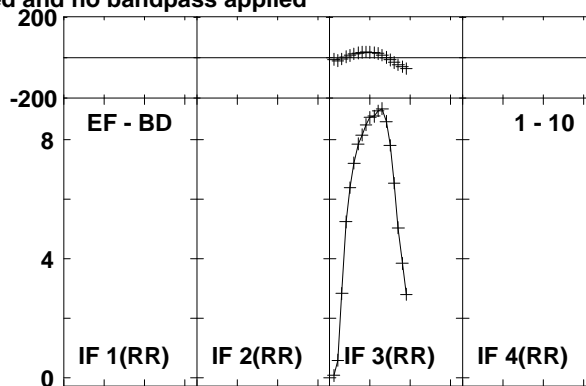
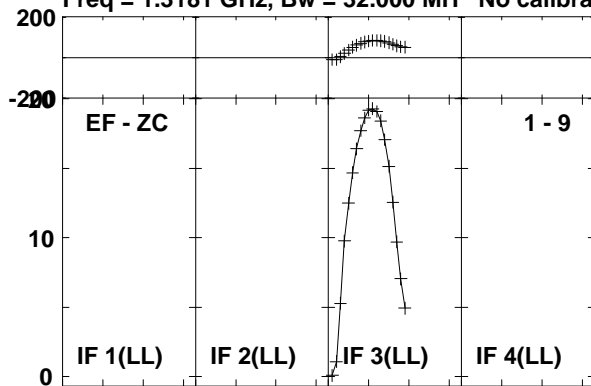

Lower frame: Milli Ampl Jy Top frame: Phas deg
Vector averaged cross-power spectrum Baseline: EF (01) - ZC (09)
Timerange: 00/06:16:38 to 00/06:26:34

Plot file version 66 created 20-NOV-2015 13:43:53

DA193 EO013 1.UVDATA.1

Freq = 1.3181 GHz, Bw = 32.000 MH No calibration applied and no bandpass applied

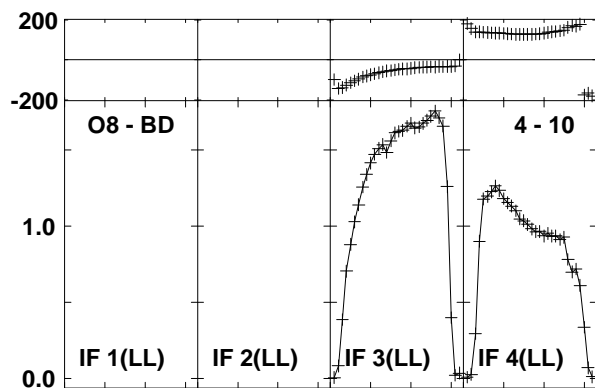
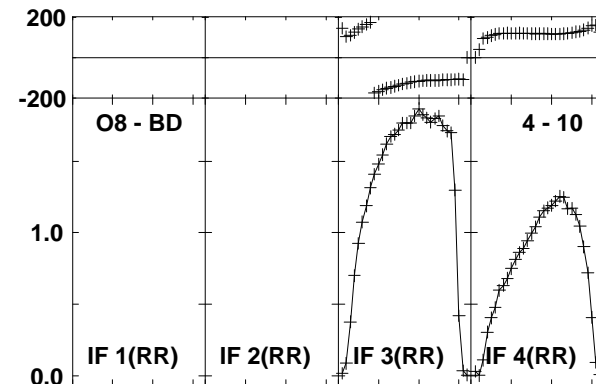
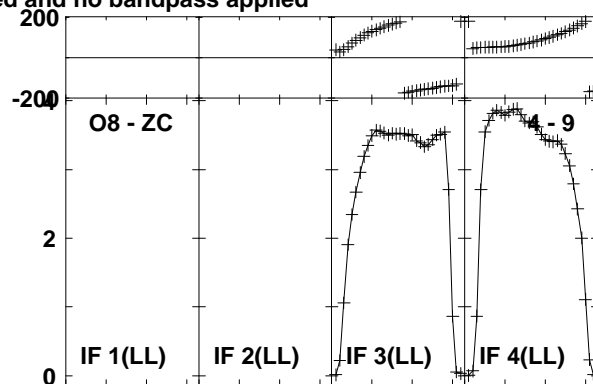
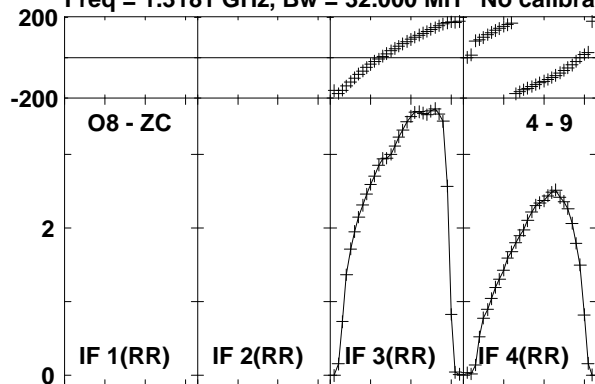

Lower frame: Milli Ampl Jy Top frame: Phas deg
Vector averaged cross-power spectrum Baseline: O8 (04) - ZC (09)
Timerange: 00/06:16:38 to 00/06:26:34

Plot file version 67 created 20-NOV-2015 13:43:53

3C84 EO013 1.UVDATA.1

Freq = 1.3181 GHz, Bw = 32.000 MH No calibration applied and no bandpass applied

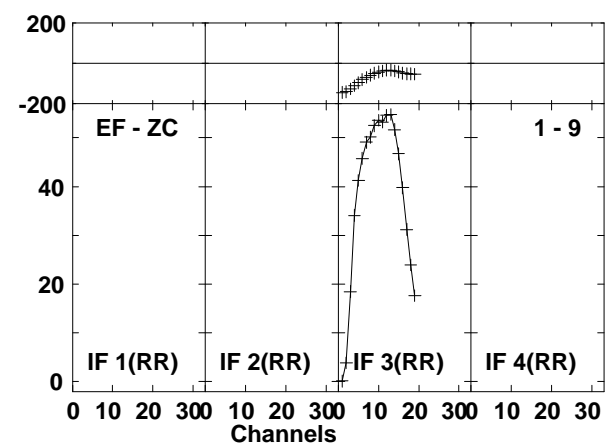
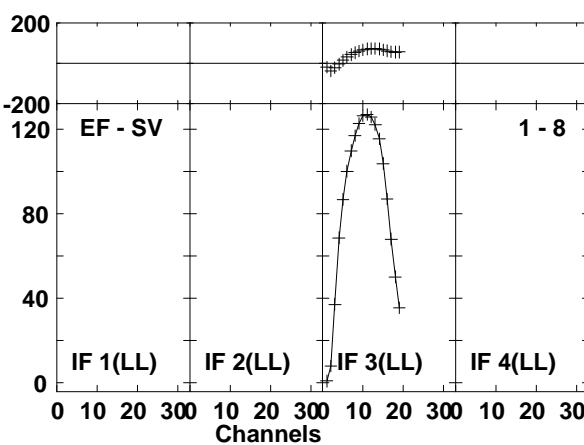
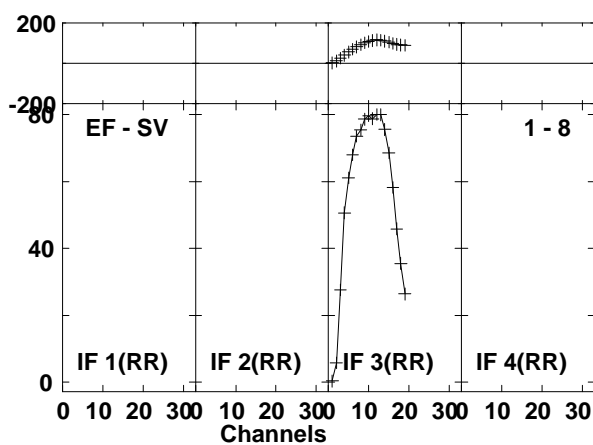
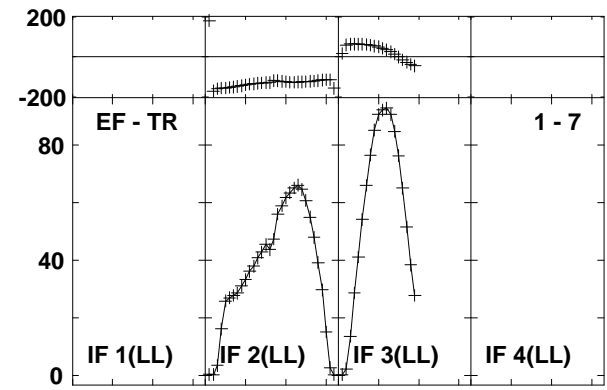
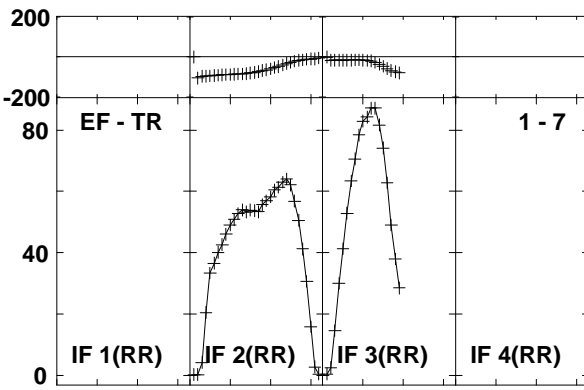
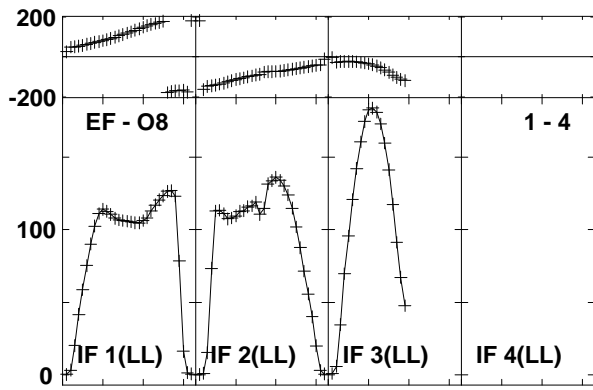
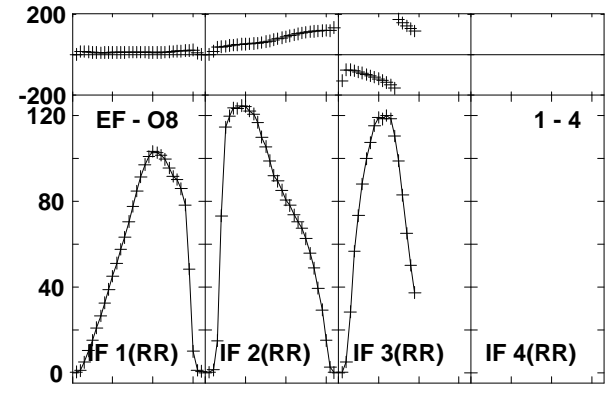
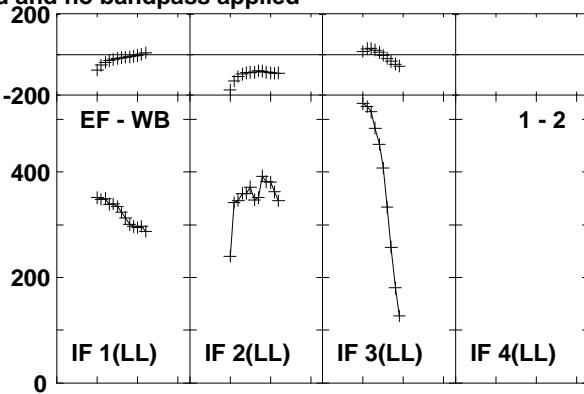
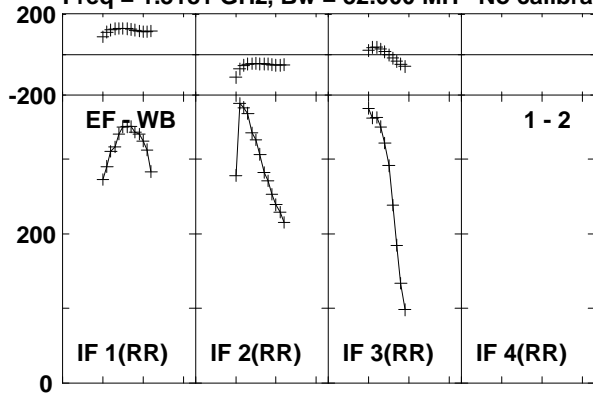

Lower frame: Milli Ampl Jy Top frame: Phas deg
Vector averaged cross-power spectrum Baseline: EF (01) - WB (02)
Timerange: 00/06:29:53 to 00/06:39:49

Plot file version 68 created 20-NOV-2015 13:43:54
 3C84 EO013 1.UVDATA.1
 Freq = 1.3181 GHz, Bw = 32.000 MH No calibration applied and no bandpass applied

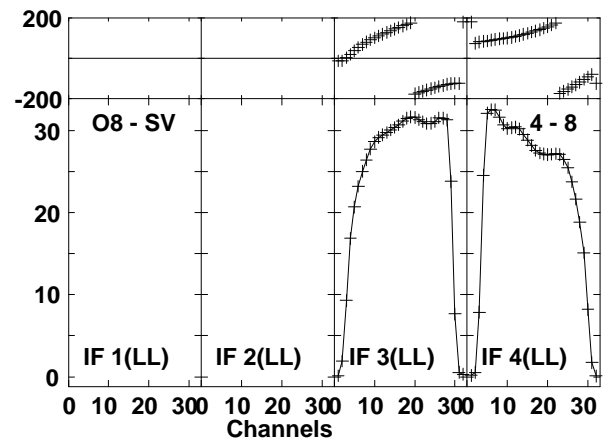
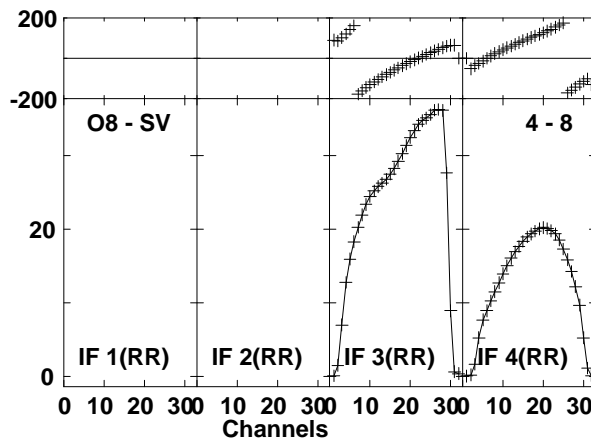
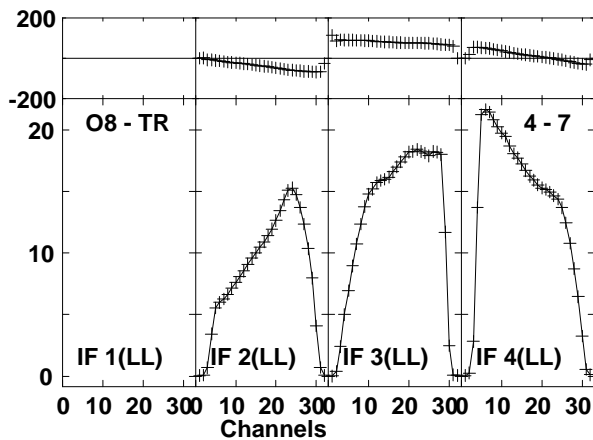
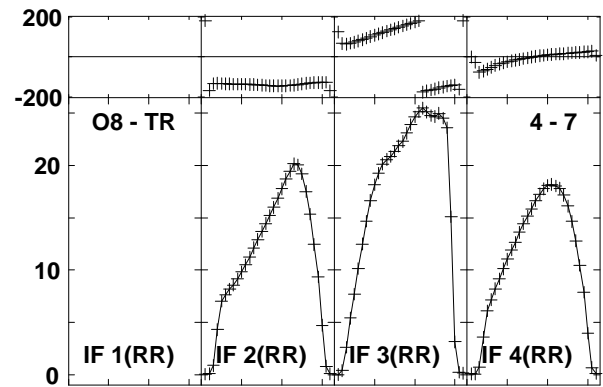
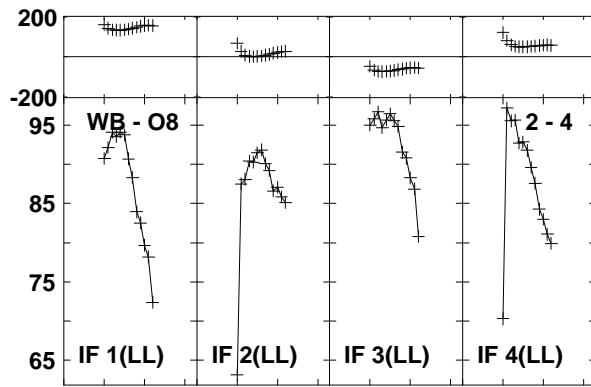
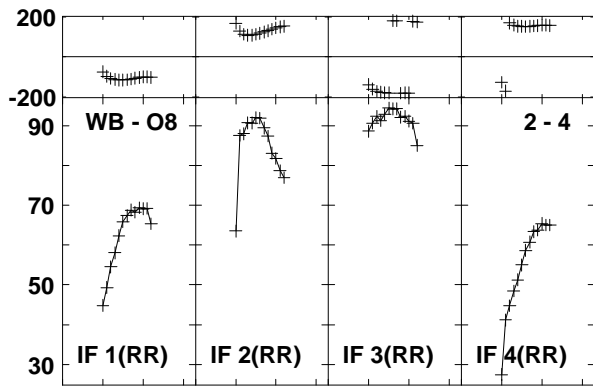
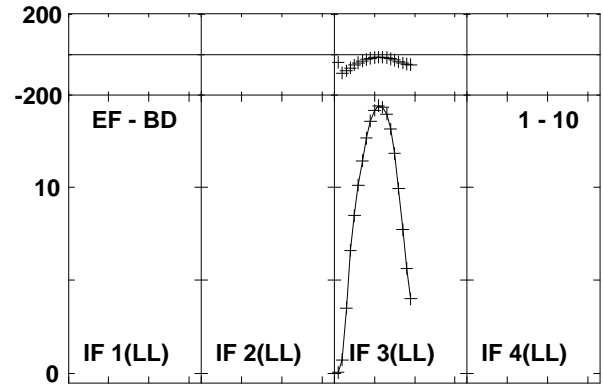
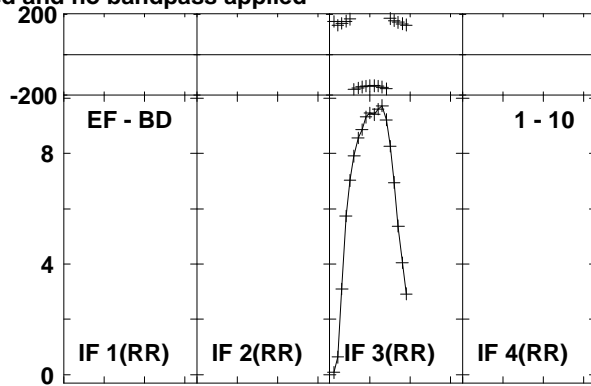
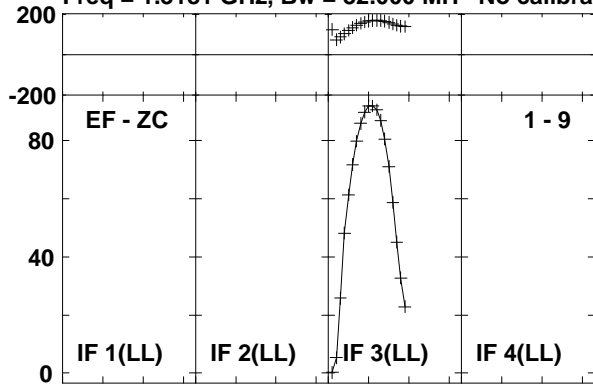

Lower frame: Milli Ampl Jy Top frame: Phas deg
 Vector averaged cross-power spectrum Baseline: EF (01) - ZC (09)
 Timerange: 00/06:29:53 to 00/06:39:49

Plot file version 69 created 20-NOV-2015 13:43:54

3C84 EO013 1.UVDATA.1

Freq = 1.3181 GHz, Bw = 32.000 MH No calibration applied and no bandpass applied

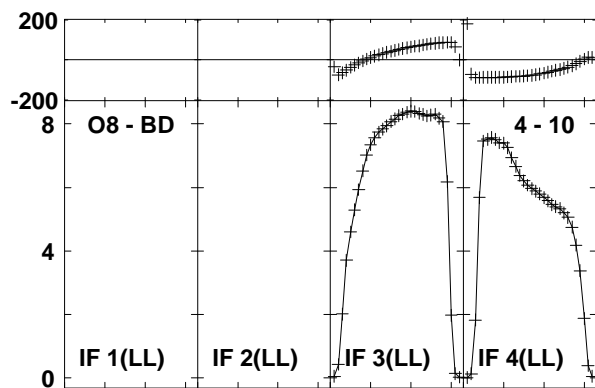
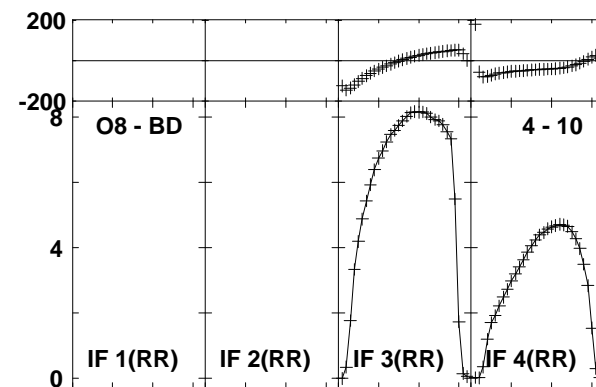
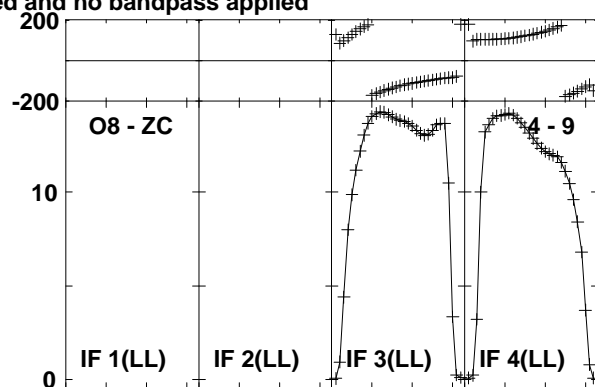
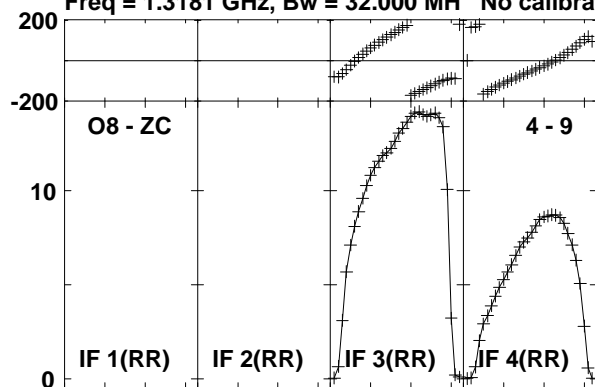

Lower frame: Milli Ampl Jy Top frame: Phas deg
Vector averaged cross-power spectrum Baseline: O8 (04) - ZC (09)
Timerange: 00/06:29:53 to 00/06:39:49

Plot file version 70 created 20-NOV-2015 13:43:54
 3C84 EO013 1.UVDATA.1
 Freq = 1.3181 GHz, Bw = 32.000 MH No calibration applied and no bandpass applied

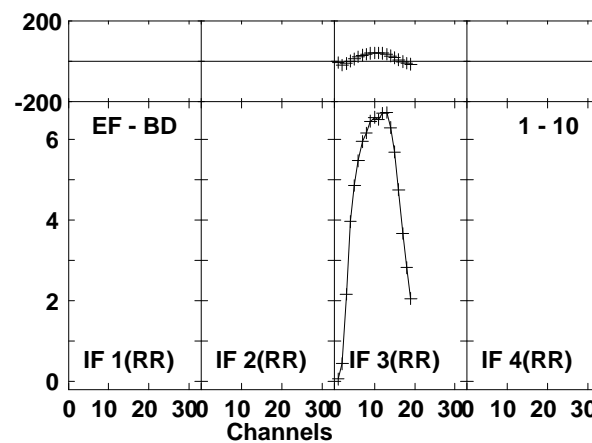
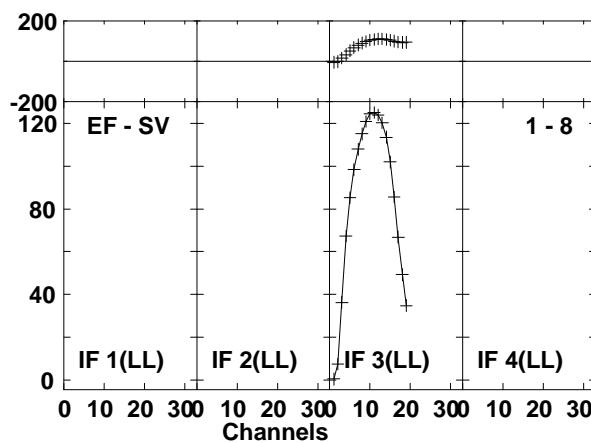
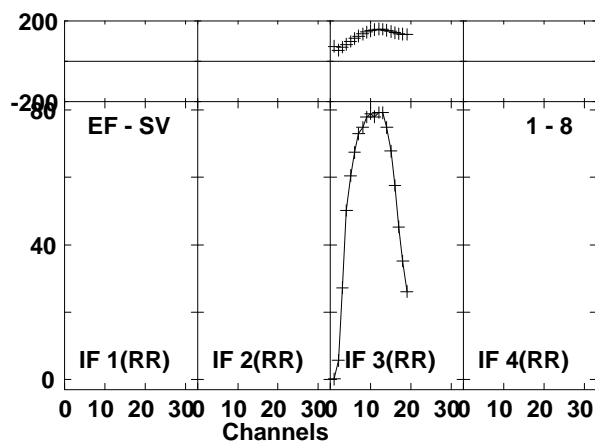
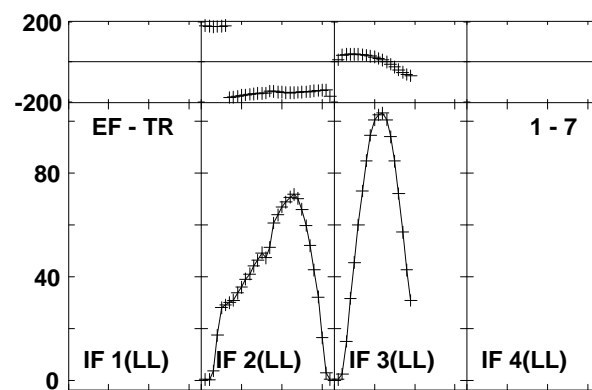
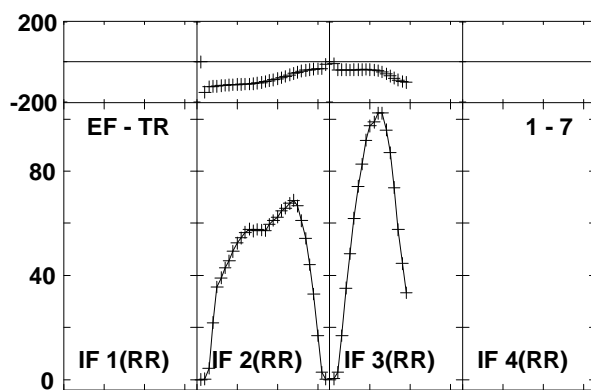
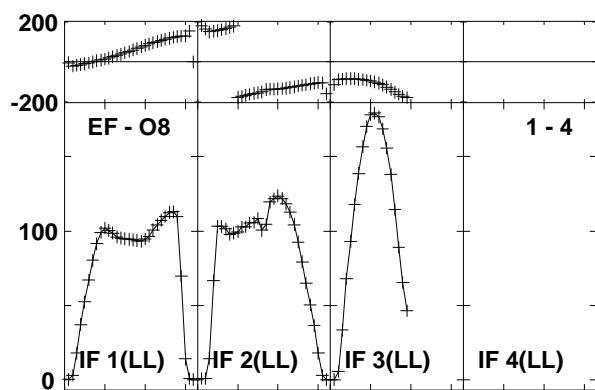
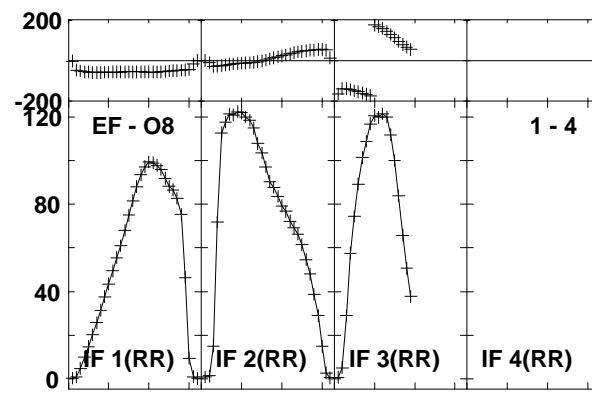
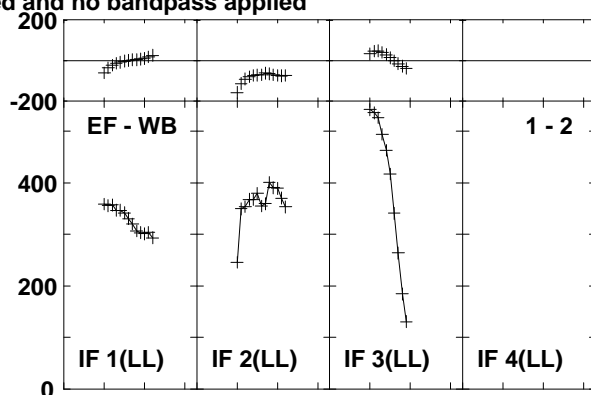
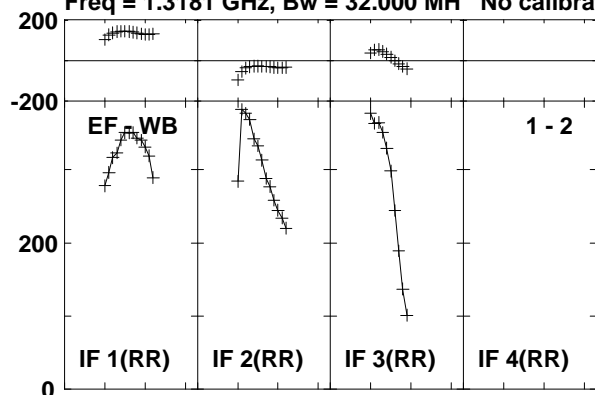

Lower frame: Milli Ampl Jy Top frame: Phas deg
 Vector averaged cross-power spectrum Baseline: EF (01) - WB (02)
 Timerange: 00/06:40:23 to 00/06:50:19

Plot file version 71 created 20-NOV-2015 13:43:54
 3C84 EO013 1.UVDATA.1
 Freq = 1.3181 GHz, Bw = 32.000 MH No calibration applied and no bandpass applied

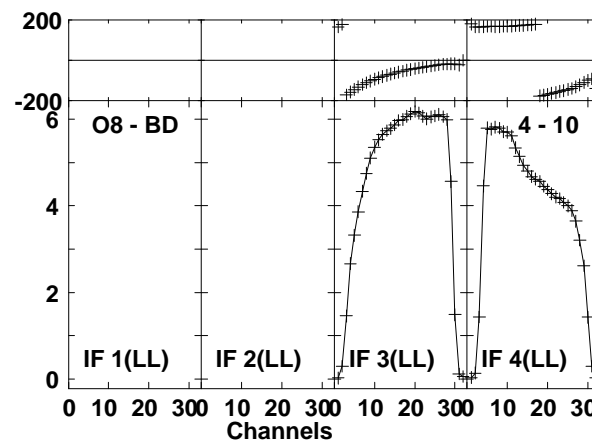
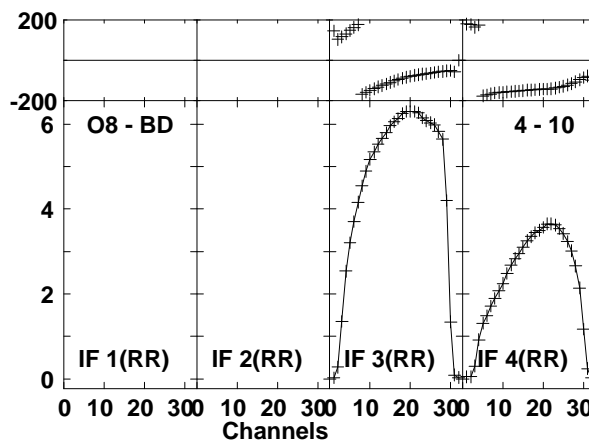
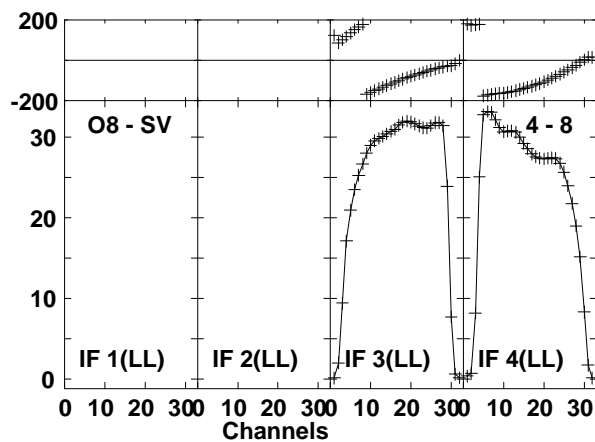
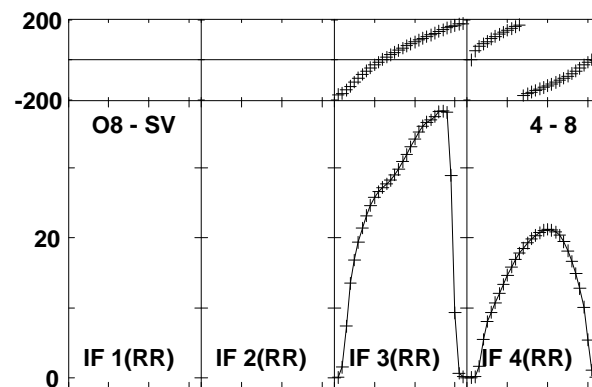
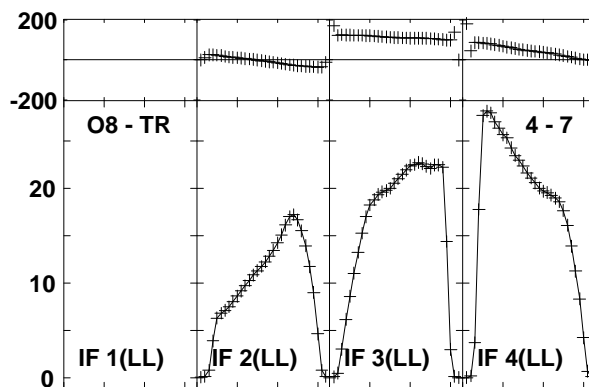
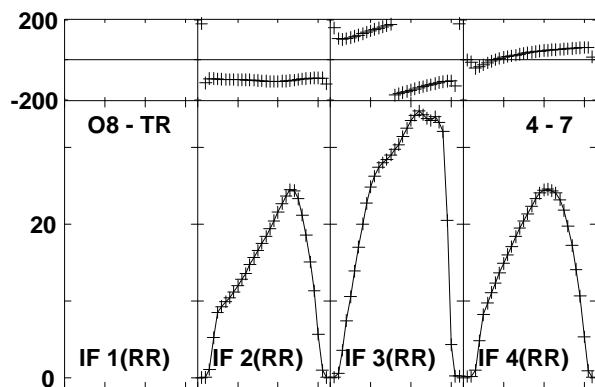
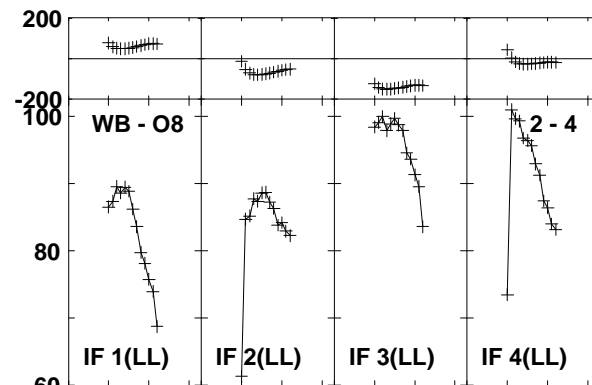
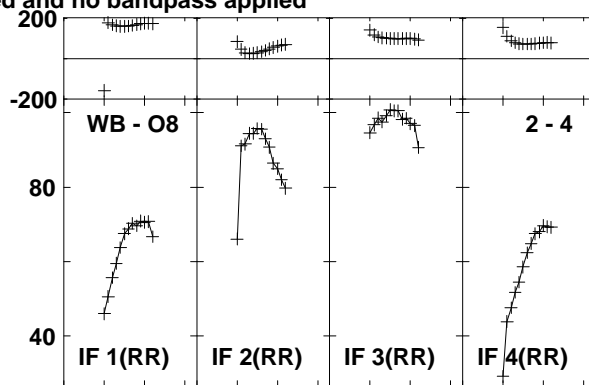
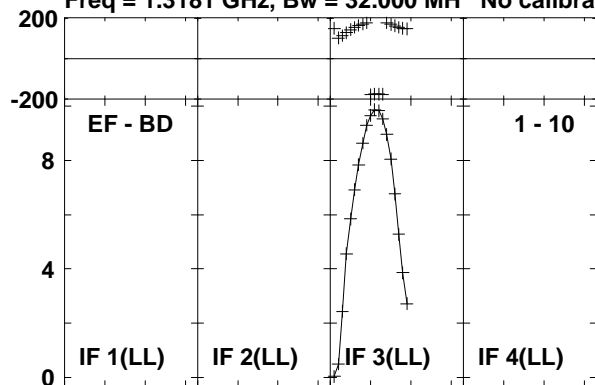

Lower frame: Milli Ampl Jy Top frame: Phas deg
 Vector averaged cross-power spectrum Baseline: EF (01) - BD (10)
 Timerange: 00/06:40:23 to 00/06:50:19

Plot file version 72 created 20-NOV-2015 13:43:54

3C84 EO013 1.UVDATA.1

Freq = 1.3181 GHz, Bw = 32.000 MH No calibration applied and no bandpass applied

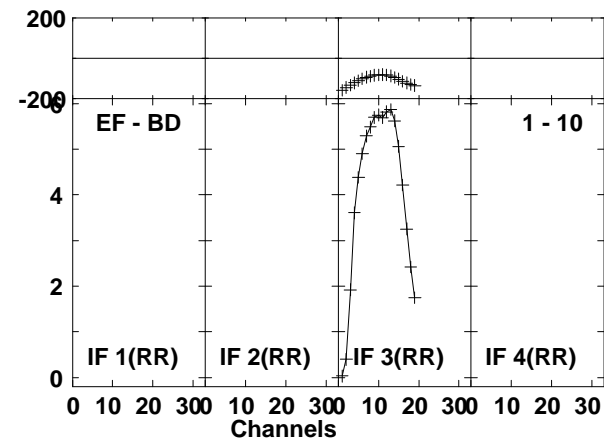
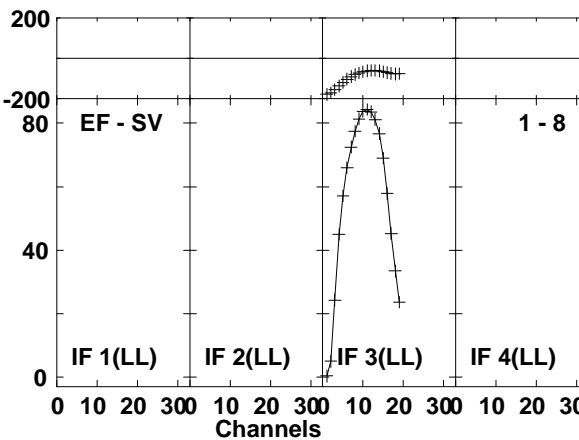
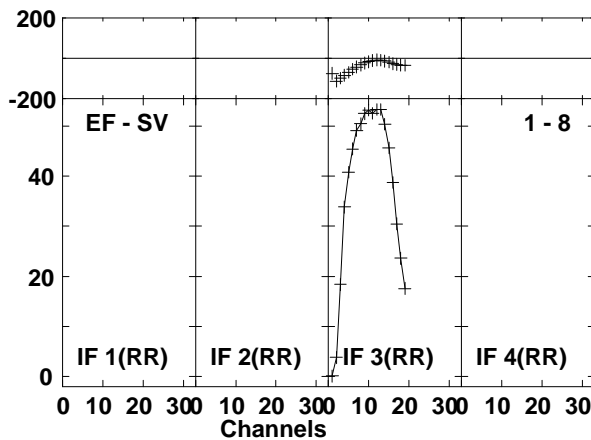
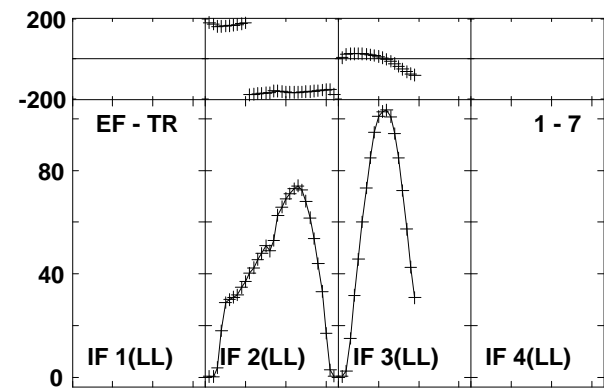
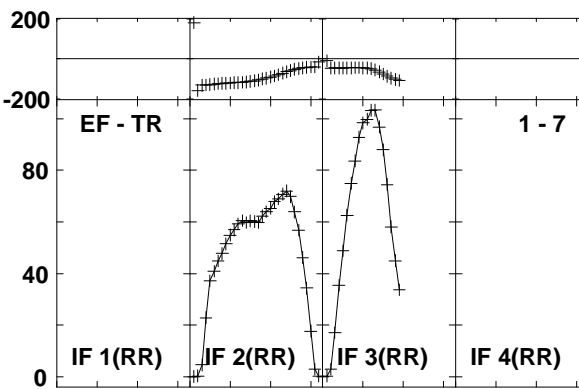
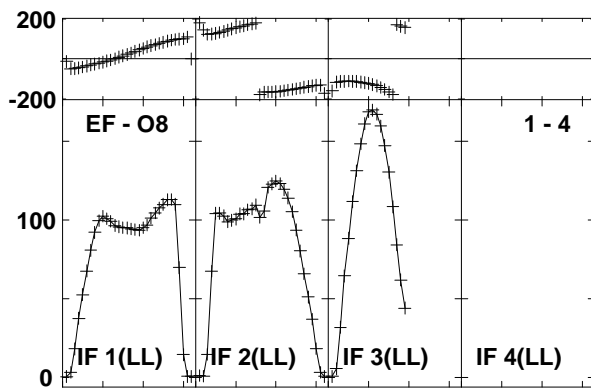
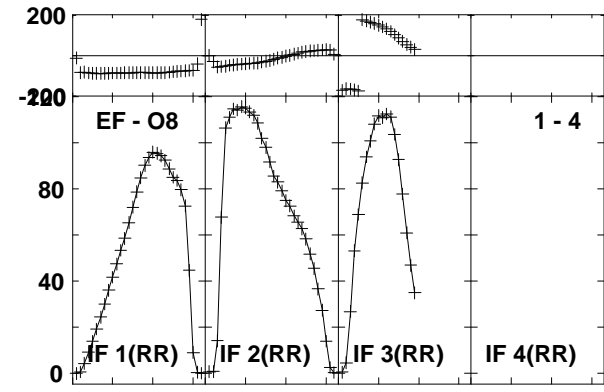
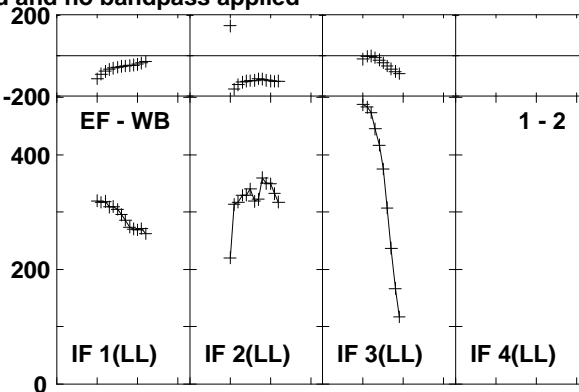
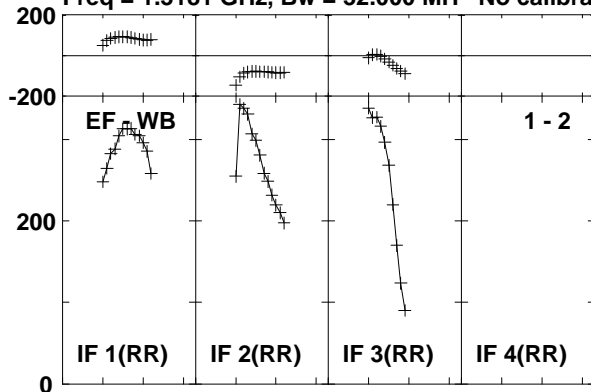

Lower frame: Milli Ampl Jy Top frame: Phas deg
Vector averaged cross-power spectrum Baseline: EF (01) - WB (02)
Timerange: 00/06:50:53 to 00/07:00:49

Plot file version 73 created 20-NOV-2015 13:43:54
 3C84 EO013 1.UVDATA.1
 Freq = 1.3181 GHz, Bw = 32.000 MH No calibration applied and no bandpass applied

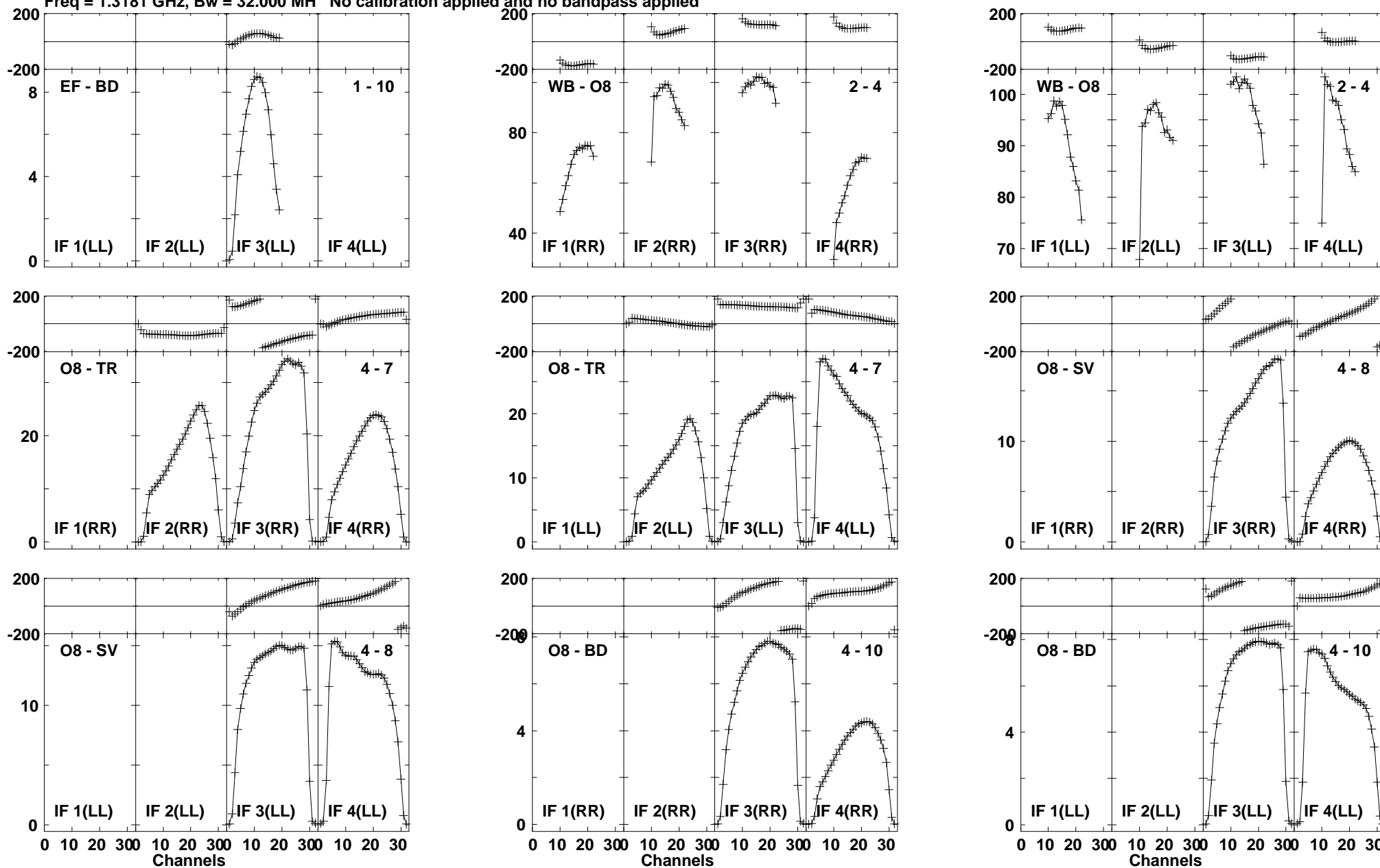

Lower frame: Milli Ampl Jy Top frame: Phas deg
 Vector averaged cross-power spectrum Baseline: EF (01) - BD (10)
 Timerange: 00/06:50:53 to 00/07:00:49

Plot file version 74 created 20-NOV-2015 13:43:54
 3C84 EO013 1.UVDATA.1
 Freq = 1.3181 GHz, Bw = 32.000 MH No calibration applied and no bandpass applied

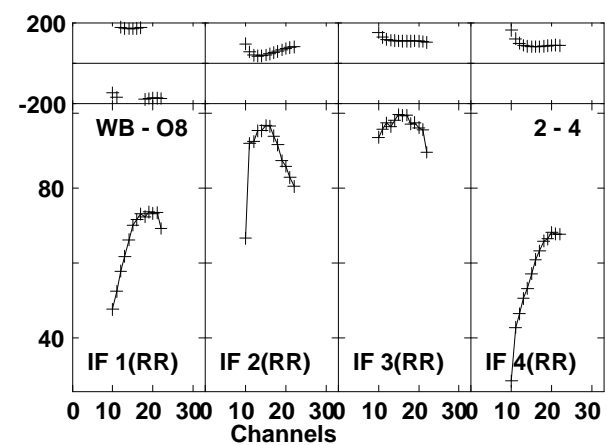
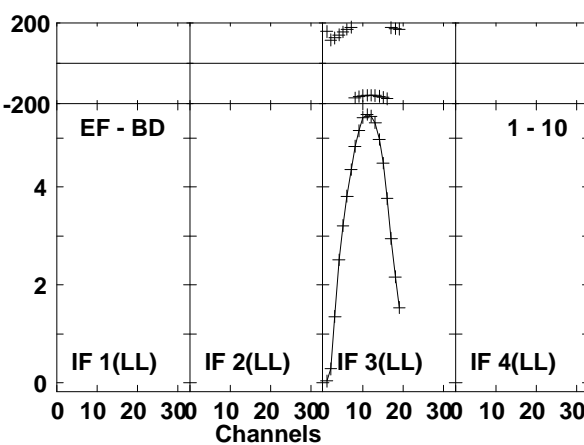
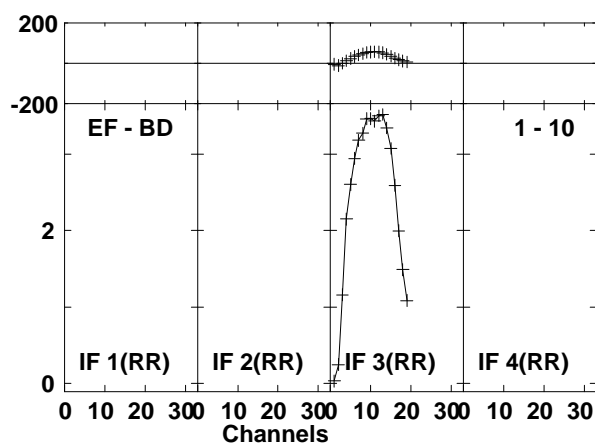
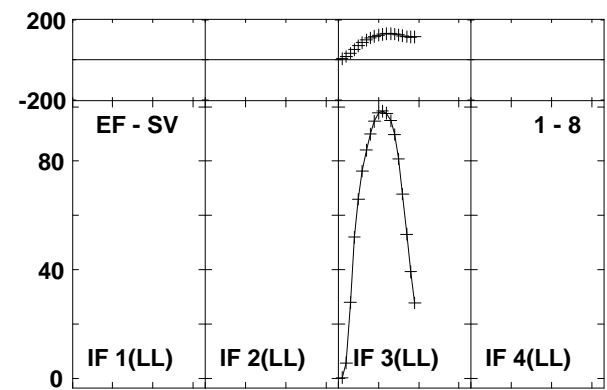
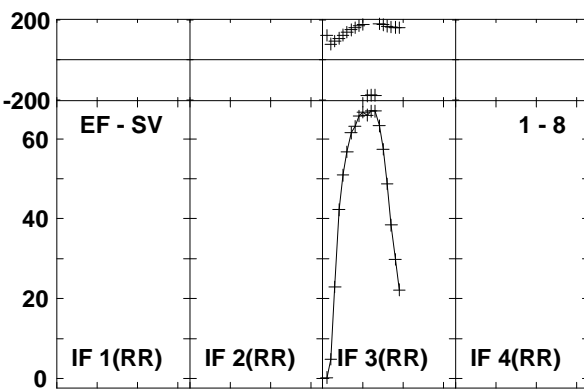
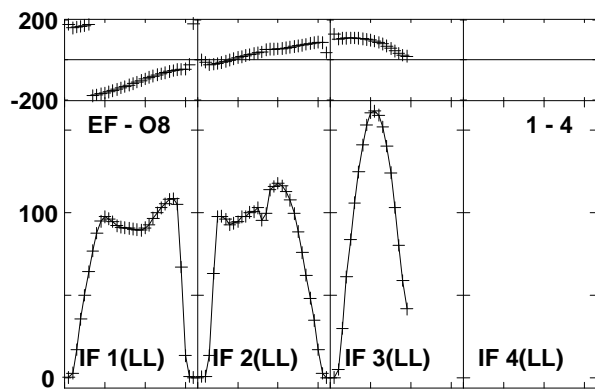
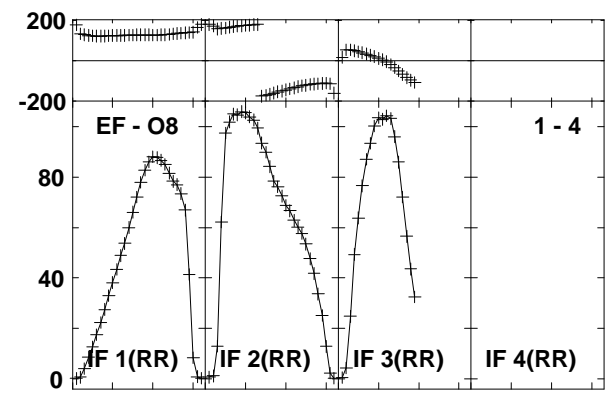
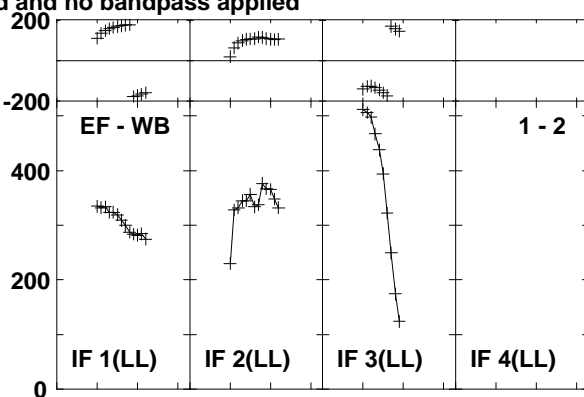
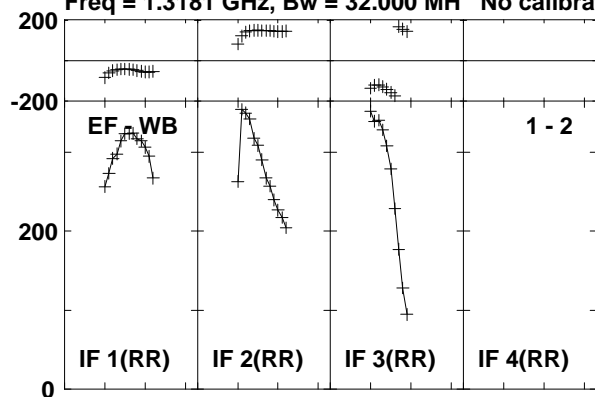

Lower frame: Milli Ampl Jy Top frame: Phas deg
 Vector averaged cross-power spectrum Baseline: EF (01) - WB (02)
 Timerange: 00/07:01:23 to 00/07:11:19

Plot file version 75 created 20-NOV-2015 13:43:54

3C84 EO013 1.UVDATA.1

Freq = 1.3181 GHz, Bw = 32.000 MH No calibration applied and no bandpass applied

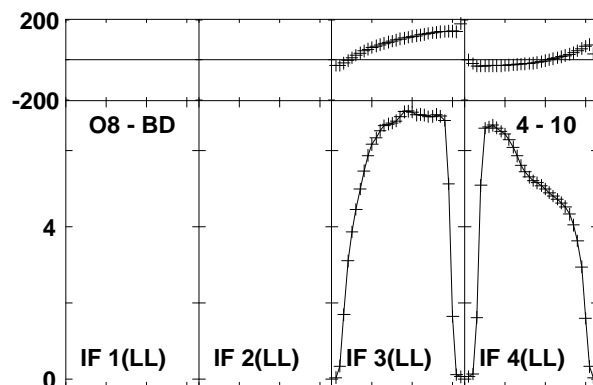
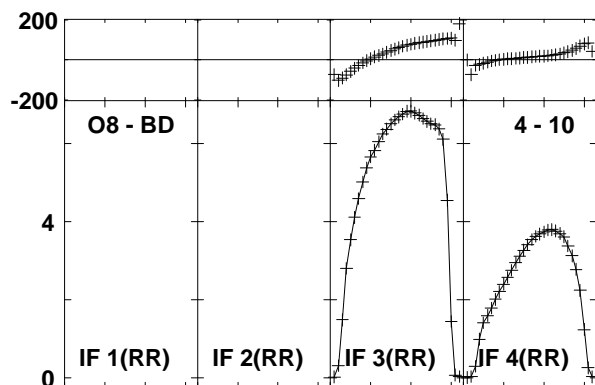
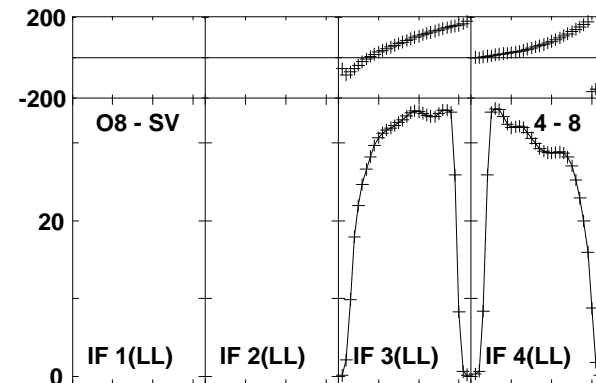
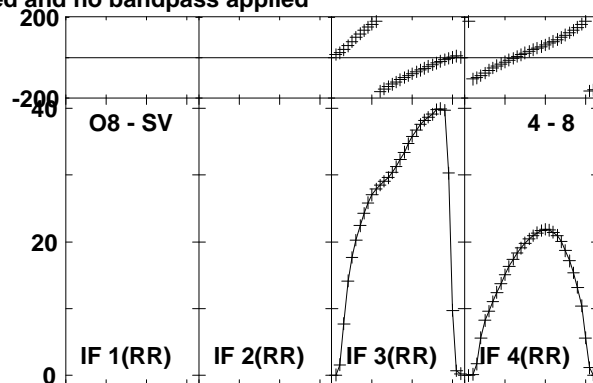
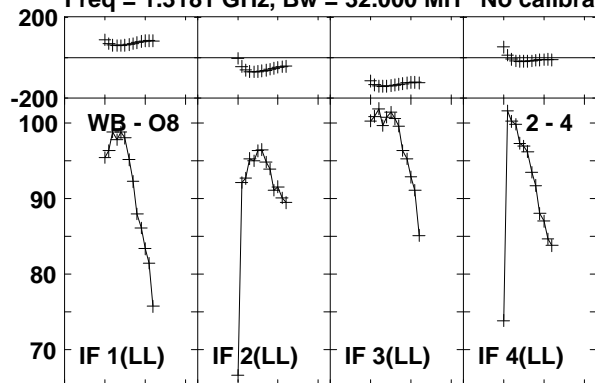

Lower frame: Milli Ampl Jy Top frame: Phas deg
Vector averaged cross-power spectrum Baseline: WB (02) - O8 (04)
Timerange: 00/07:01:23 to 00/07:11:19

Plot file version 76 created 20-NOV-2015 13:43:54

DA193 EO013 1.UVDATA.1

Freq = 1.3181 GHz, Bw = 32.000 MH No calibration applied and no bandpass applied

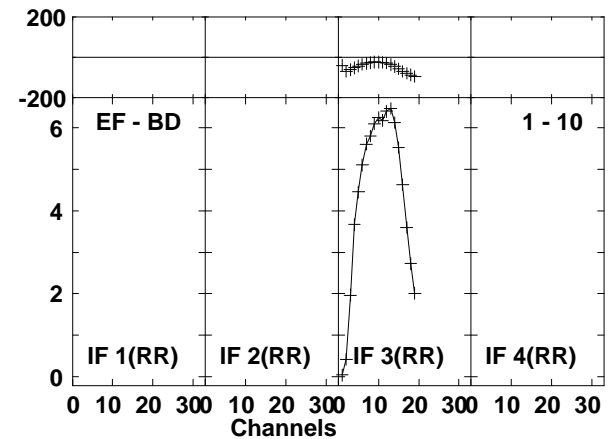
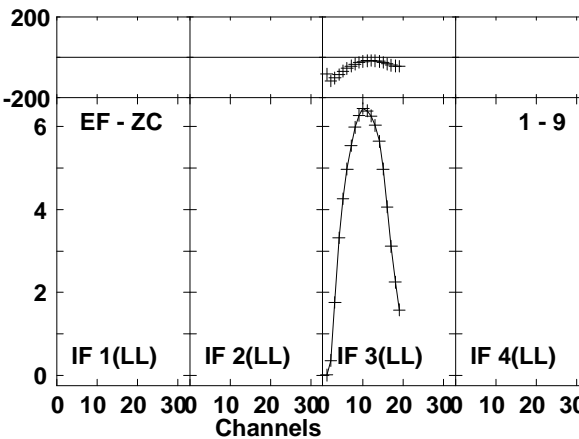
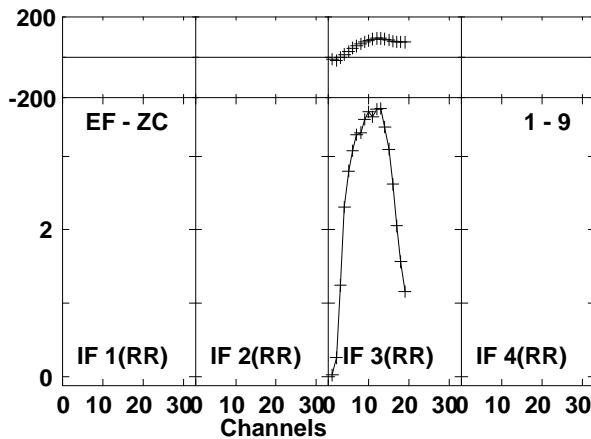
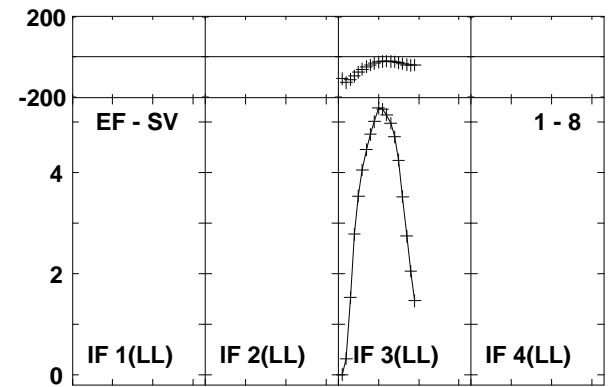
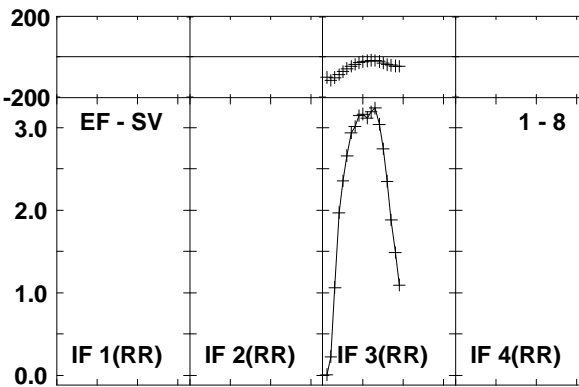
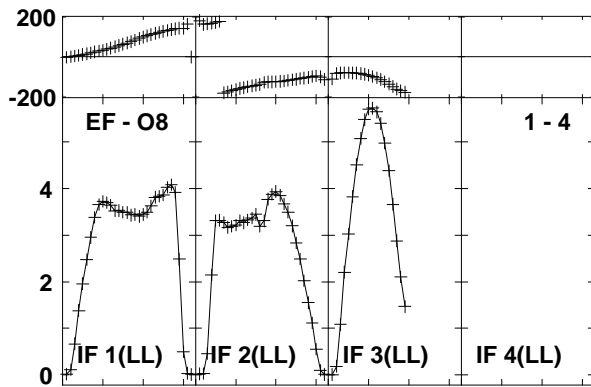
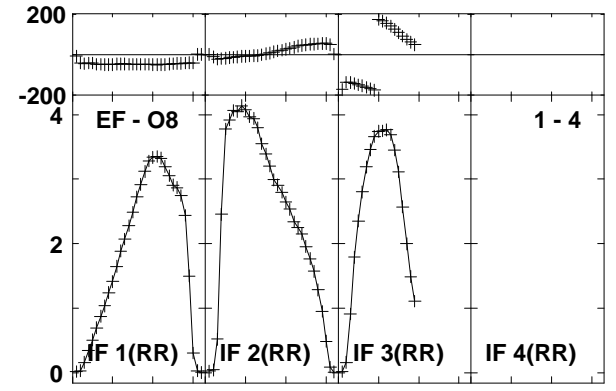
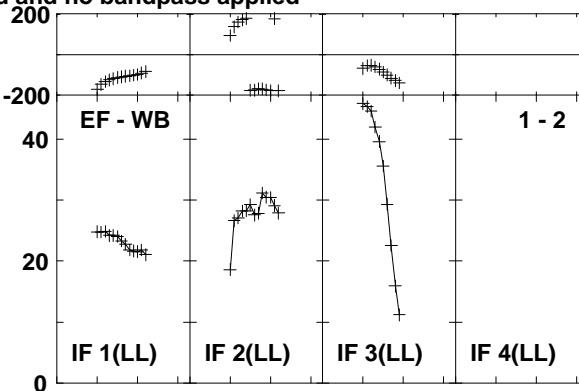
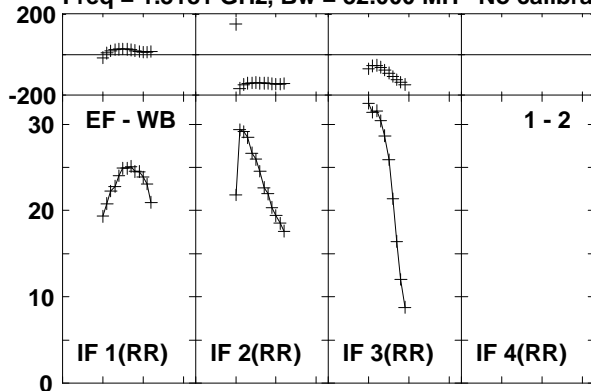

Lower frame: Milli Ampl Jy Top frame: Phas deg
Vector averaged cross-power spectrum Baseline: EF (01) - WB (02)
Timerange: 00/07:14:33 to 00/07:24:29

Plot file version 77 created 20-NOV-2015 13:43:54

DA193 EO013 1.UVDATA.1

Freq = 1.3181 GHz, Bw = 32.000 MH No calibration applied and no bandpass applied

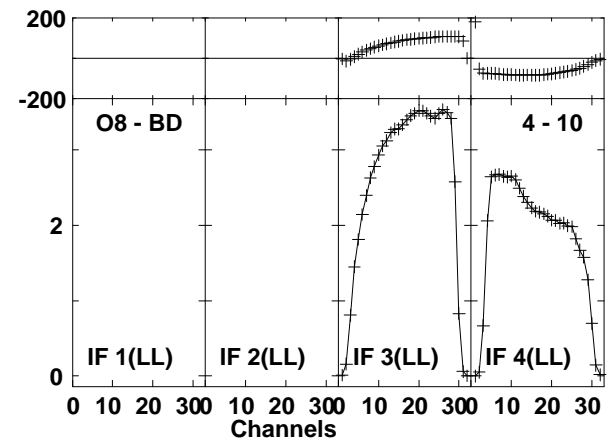
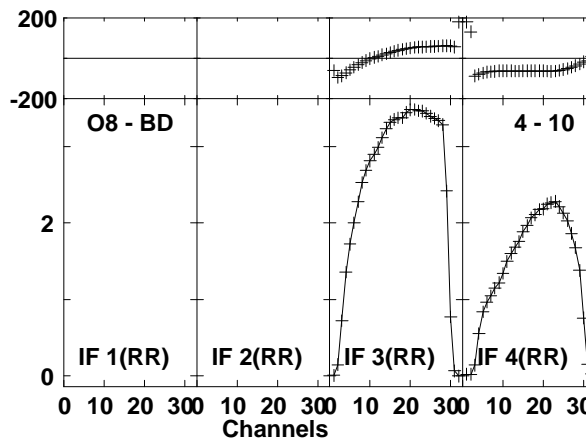
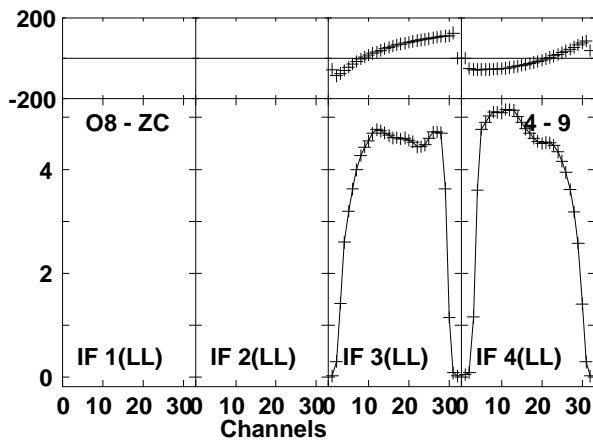
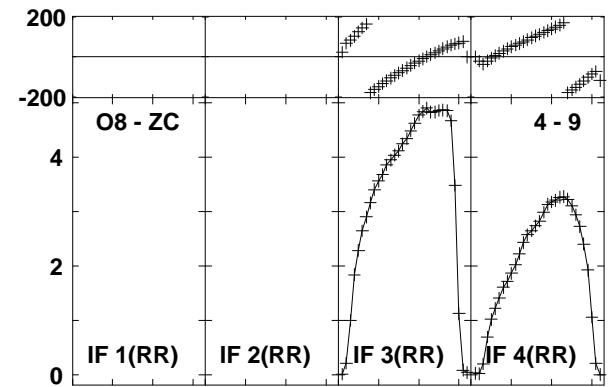
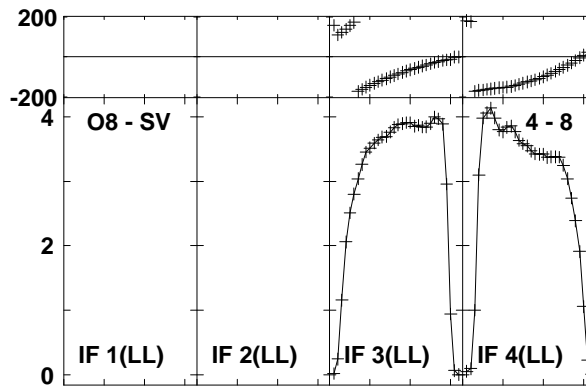
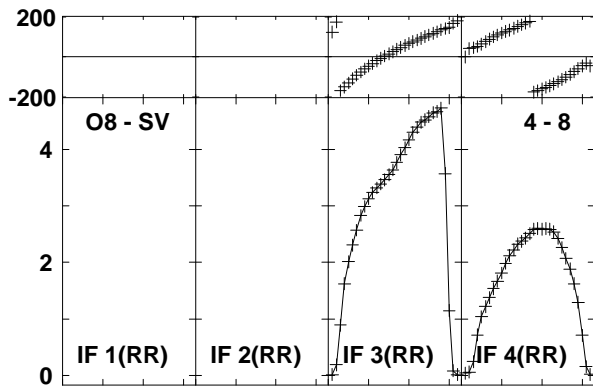
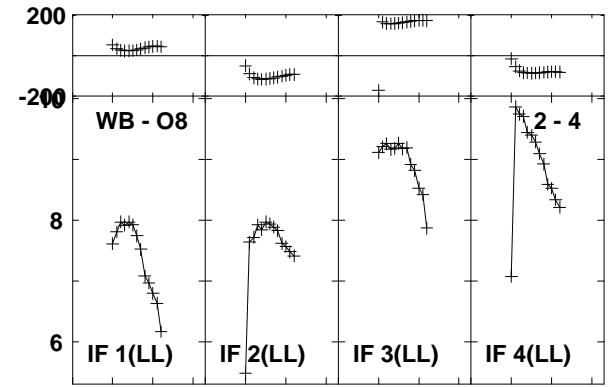
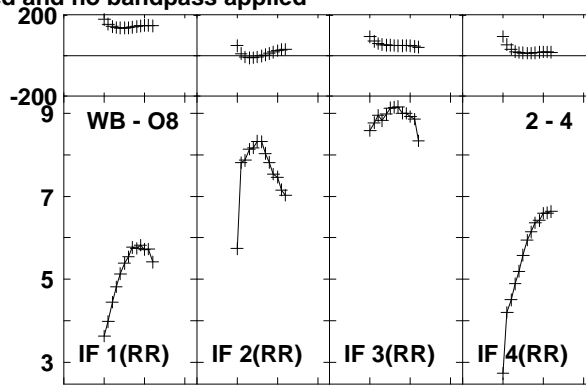
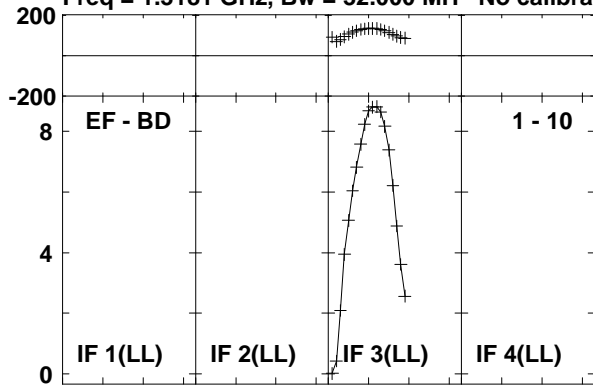

Lower frame: Milli Ampl Jy Top frame: Phas deg
Vector averaged cross-power spectrum Baseline: EF (01) - BD (10)
Timerange: 00/07:14:33 to 00/07:24:29

Plot file version 78 created 20-NOV-2015 13:43:54

DA193 EO13 1.UVDATA.1

Freq = 1.3181 GHz, Bw = 32.000 MH No calibration applied and no bandpass applied

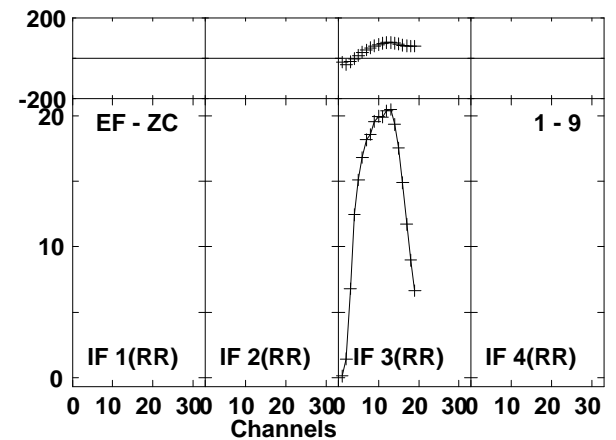
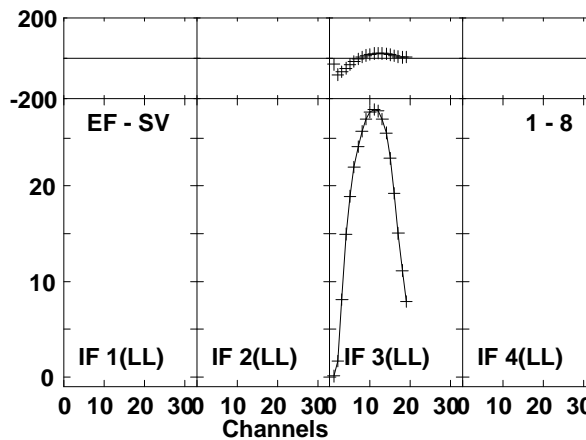
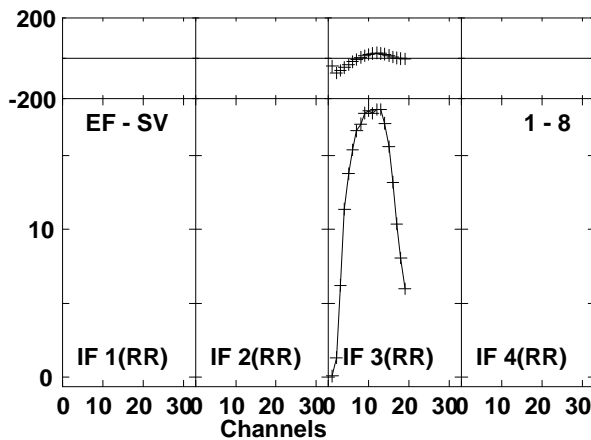
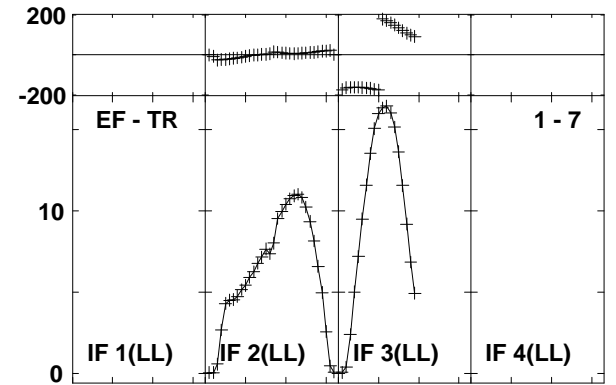
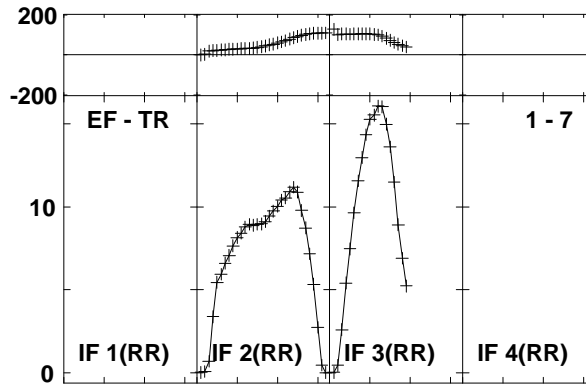
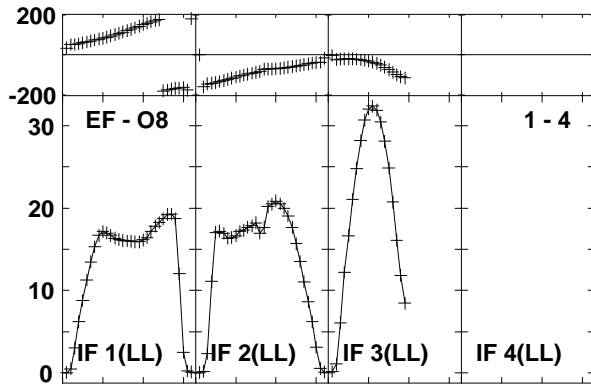
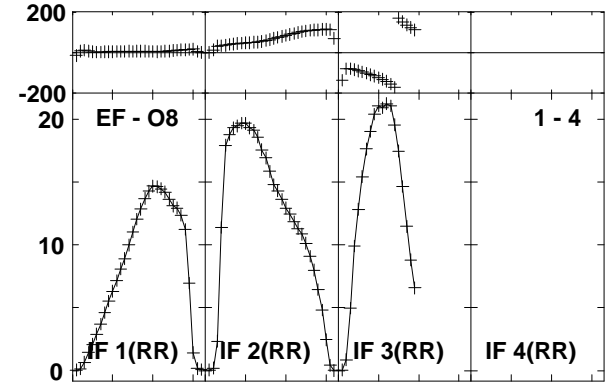
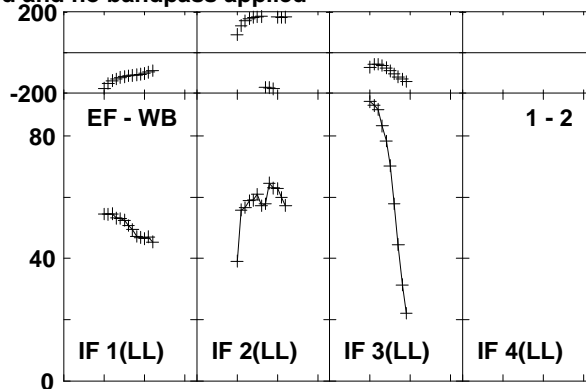
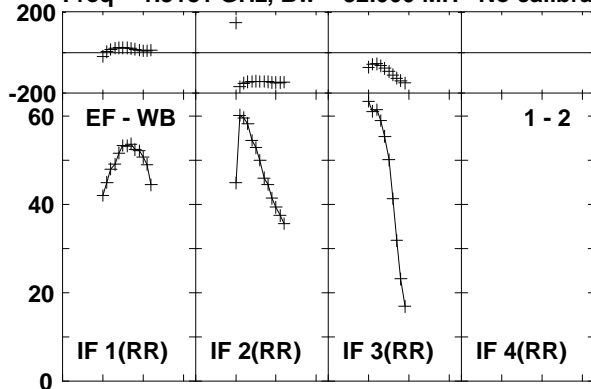

Lower frame: Milli Ampl Jy Top frame: Phas deg
Vector averaged cross-power spectrum Baseline: EF (01) - WB (02)
Timerange: 00/07:25:03 to 00/07:29:59

Plot file version 79 created 20-NOV-2015 13:43:54

DA193 EO013 1.UVDATA.1

Freq = 1.3181 GHz, Bw = 32.000 MH No calibration applied and no bandpass applied

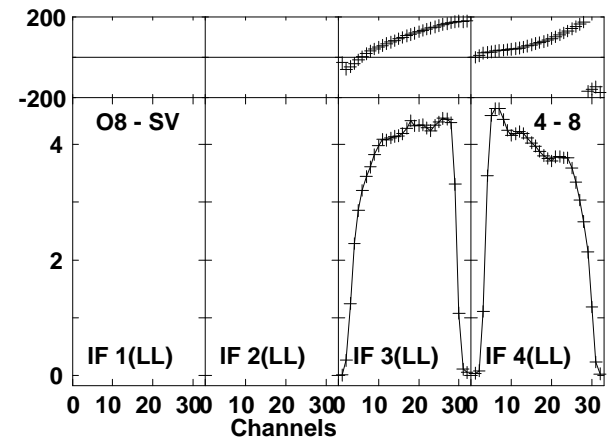
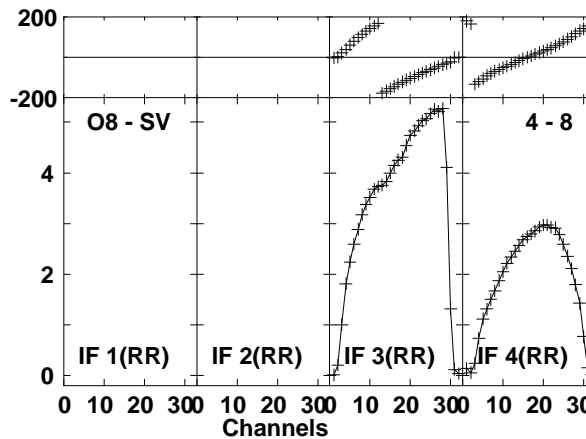
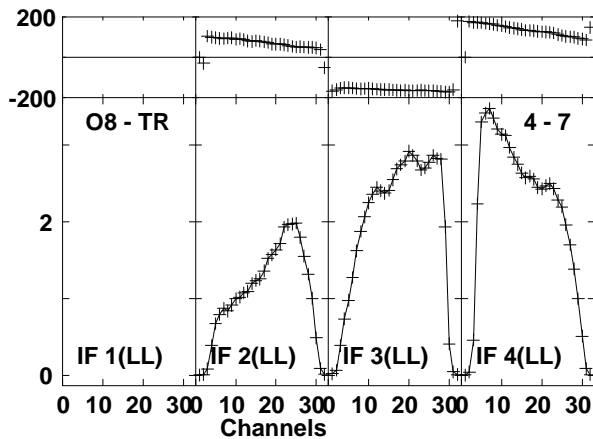
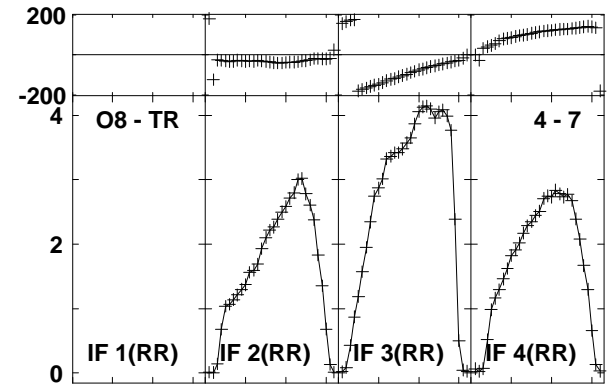
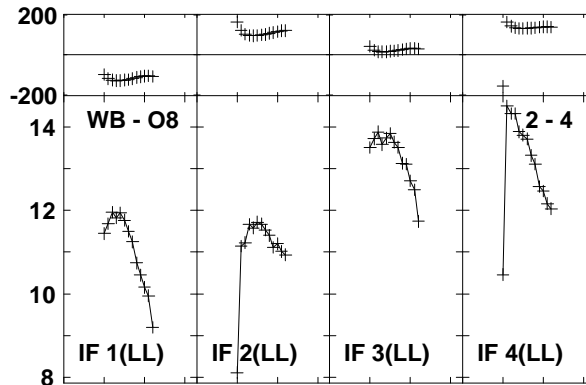
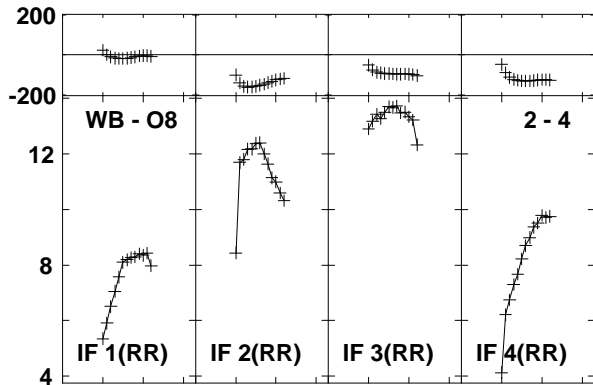
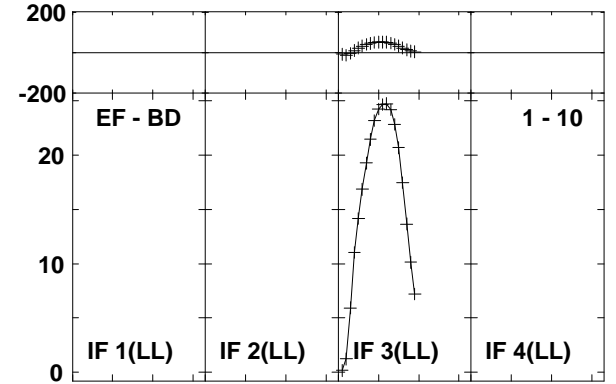
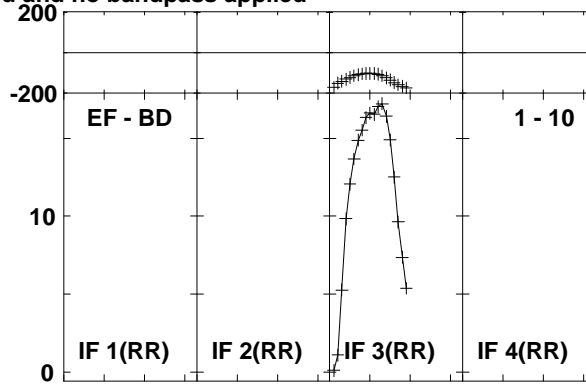
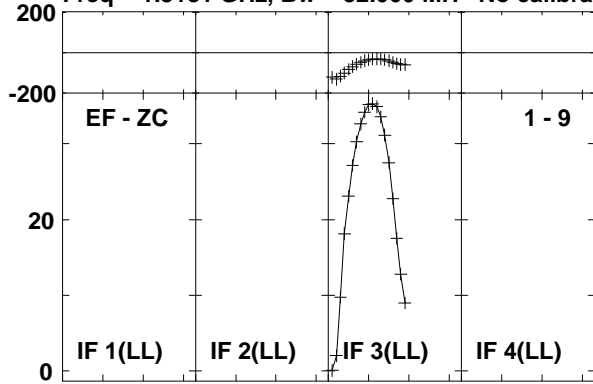

Lower frame: Milli Ampl Jy Top frame: Phas deg
Vector averaged cross-power spectrum Baseline: EF (01) - ZC (09)
Timerange: 00/07:25:03 to 00/07:29:59

Plot file version 80 created 20-NOV-2015 13:43:54

DA193 EO013 1.UVDATA.1

Freq = 1.3181 GHz, Bw = 32.000 MH No calibration applied and no bandpass applied

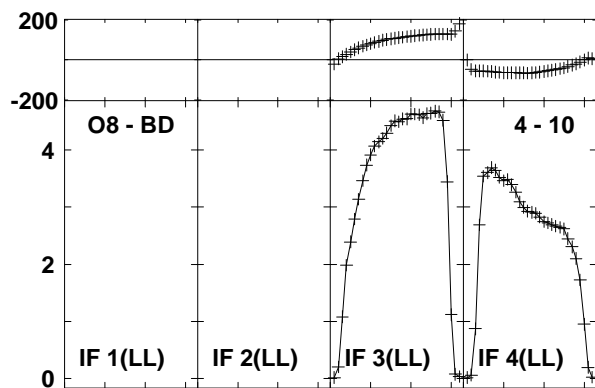
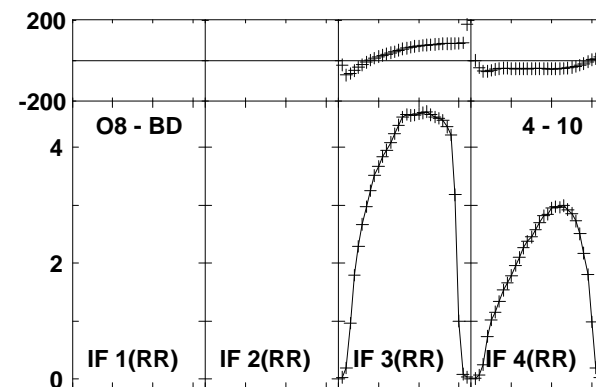
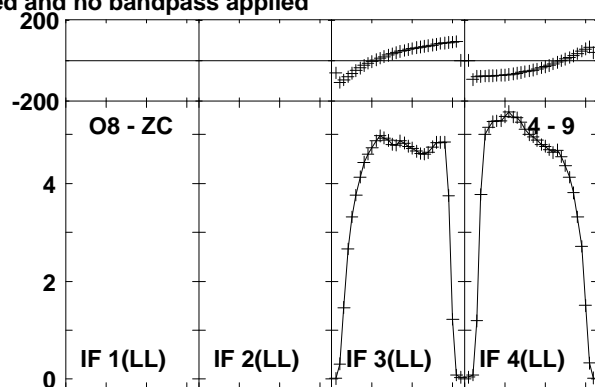
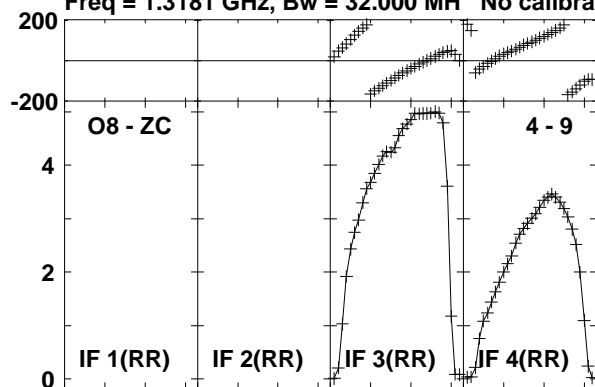

Lower frame: Milli Ampl Jy Top frame: Phas deg
Vector averaged cross-power spectrum Baseline: O8 (04) - ZC (09)
Timerange: 00/07:25:03 to 00/07:29:59

Plot file version 81 created 20-NOV-2015 13:43:55

3C84 EO013 1.UVDATA.1

Freq = 1.3181 GHz, Bw = 32.000 MH No calibration applied and no bandpass applied

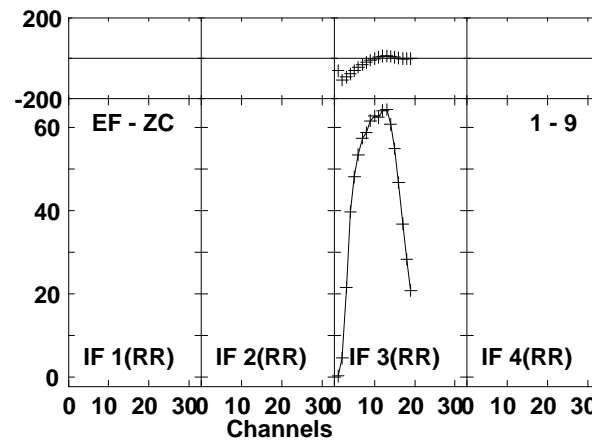
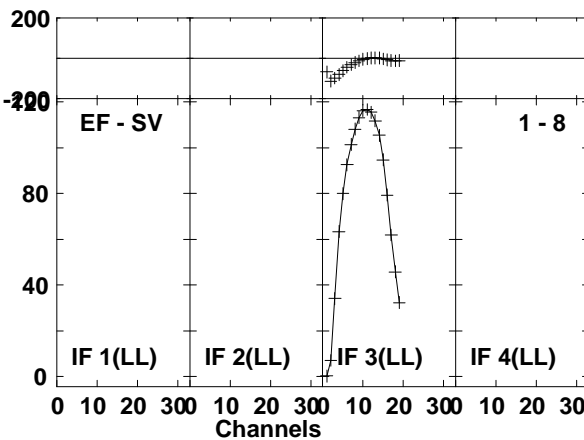
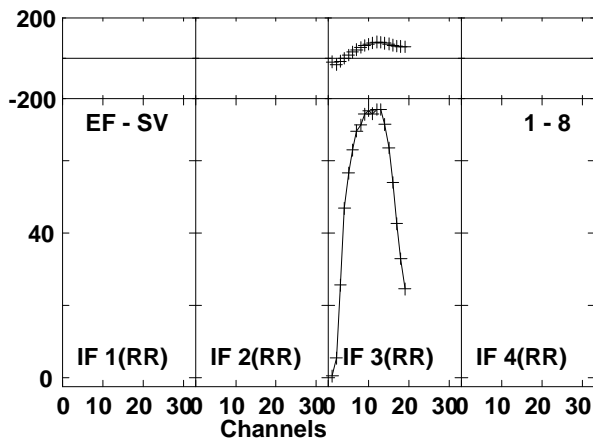
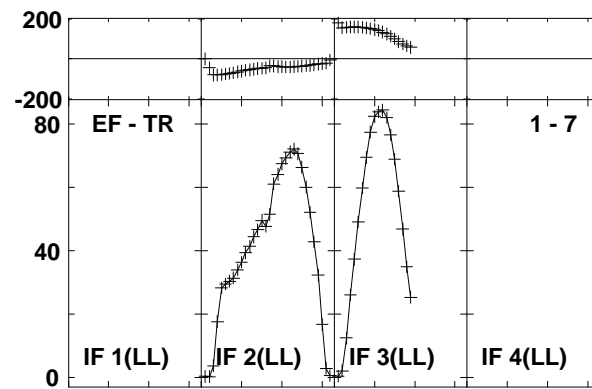
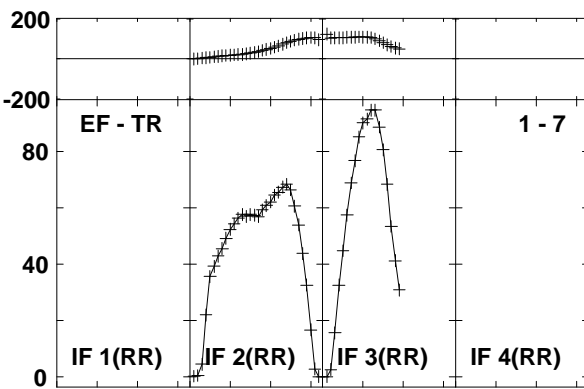
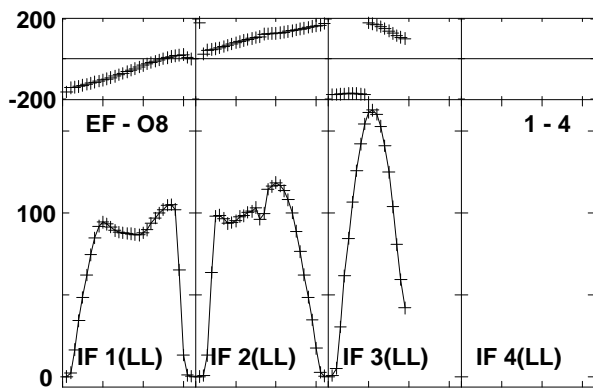
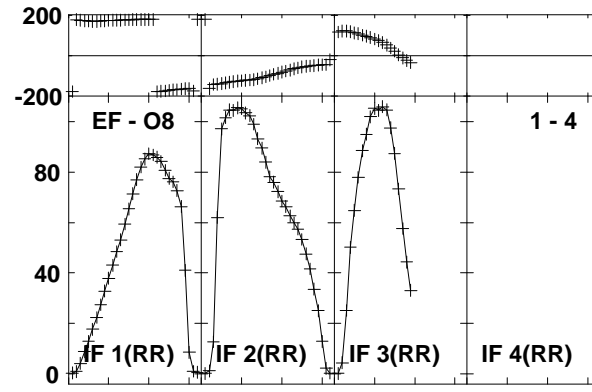
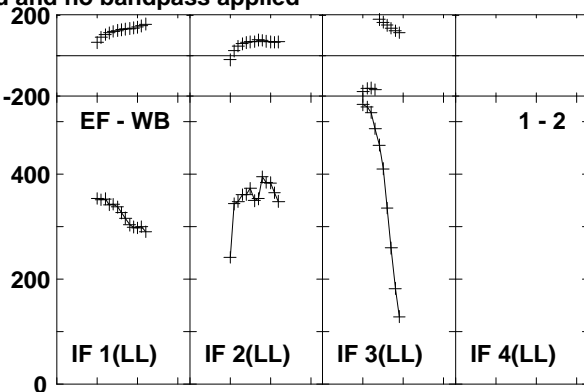
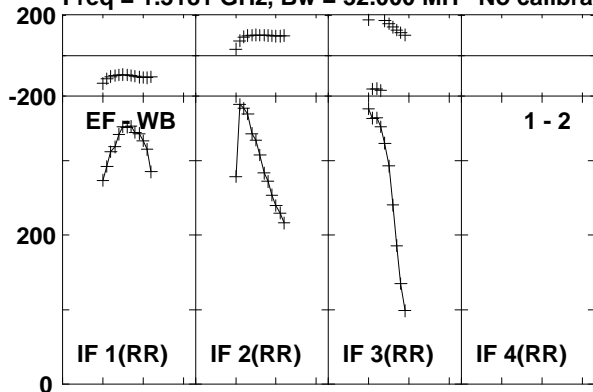

Lower frame: Milli Ampl Jy Top frame: Phas deg
Vector averaged cross-power spectrum Baseline: EF (01) - WB (02)
Timerange: 00/07:33:23 to 00/07:43:19

Plot file version 82 created 20-NOV-2015 13:43:55
 3C84 EO013 1.UVDATA.1
 Freq = 1.3181 GHz, Bw = 32.000 MH No calibration applied and no bandpass applied

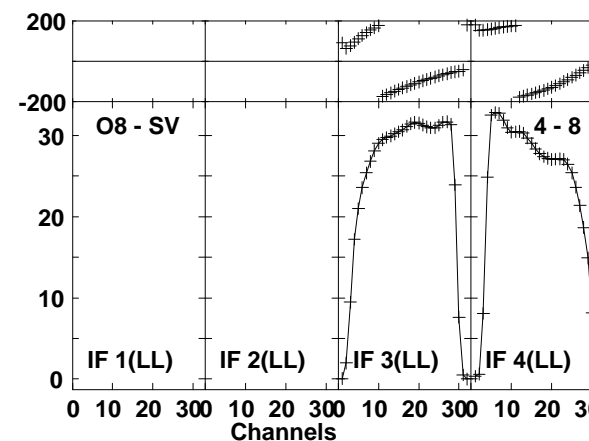
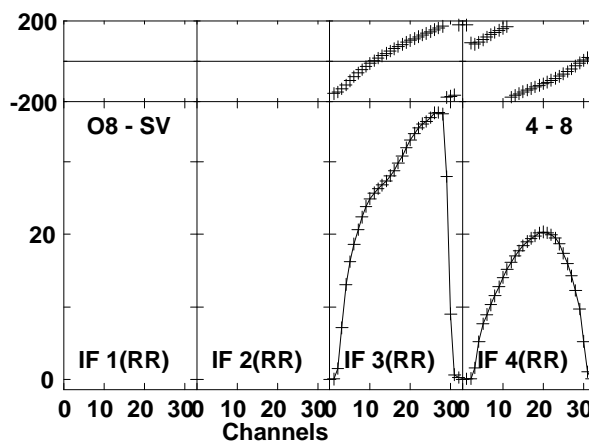
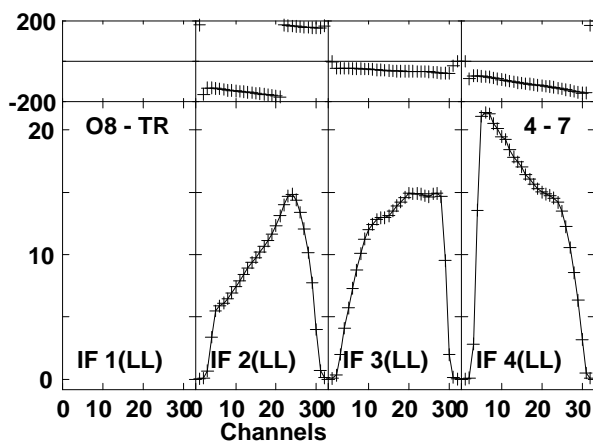
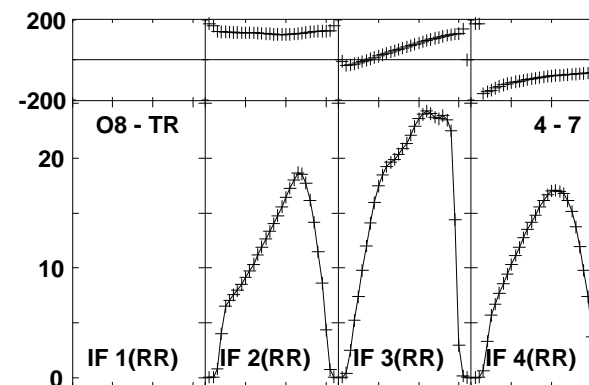
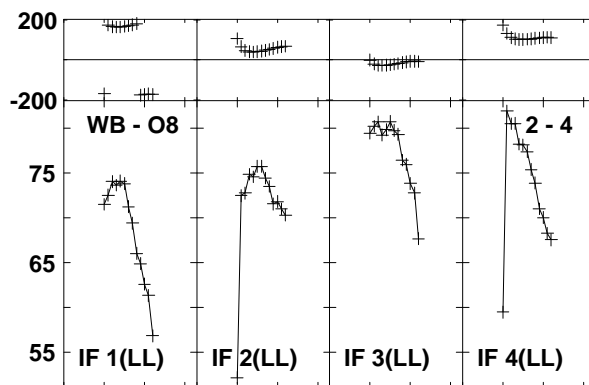
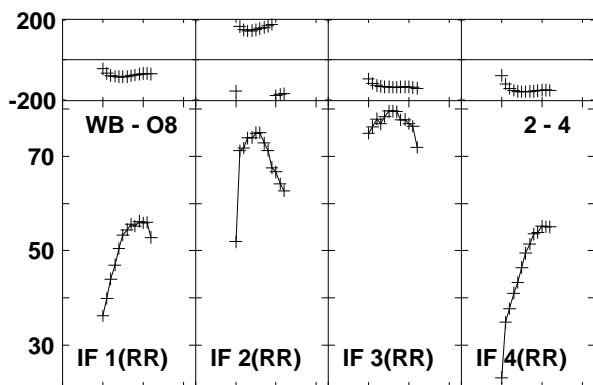
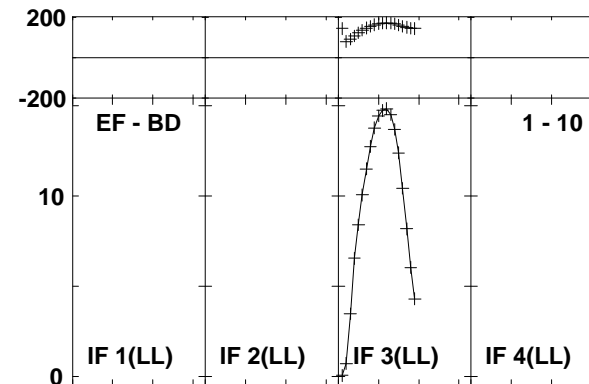
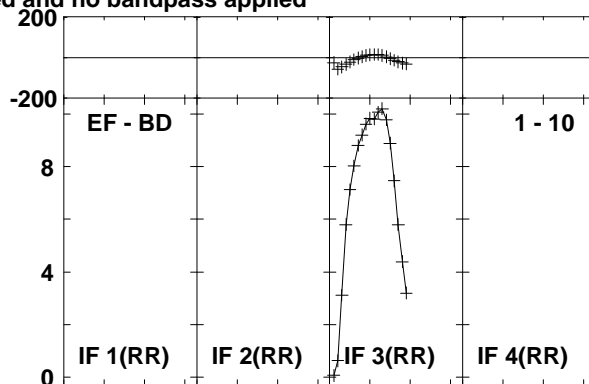
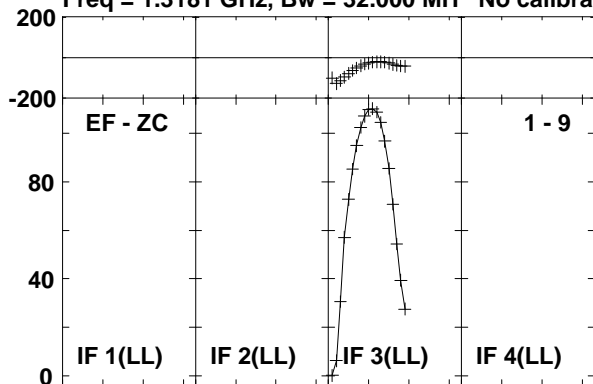

Lower frame: Milli Ampl Jy Top frame: Phas deg
 Vector averaged cross-power spectrum Baseline: EF (01) - ZC (09)
 Timerange: 00/07:33:23 to 00/07:43:19

Plot file version 83 created 20-NOV-2015 13:43:55
 3C84 EO013 1.UVDATA.1
 Freq = 1.3181 GHz, Bw = 32.000 MH No calibration applied and no bandpass applied

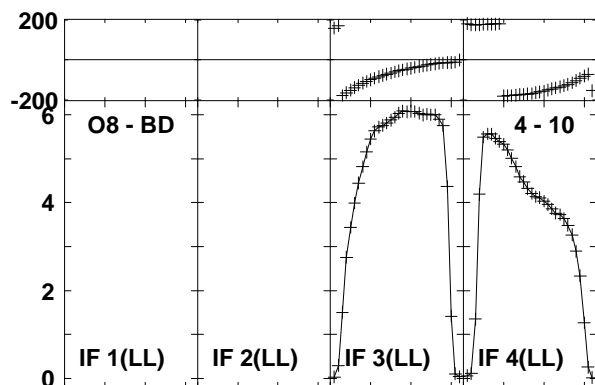
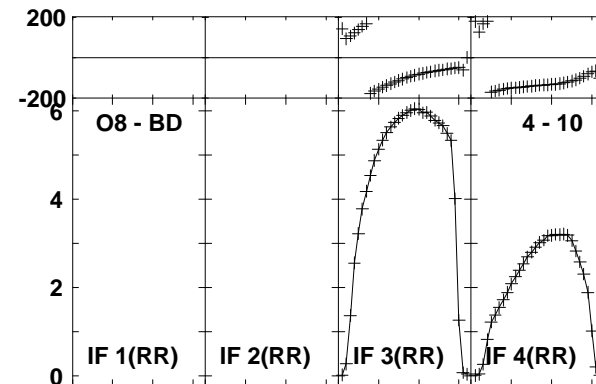
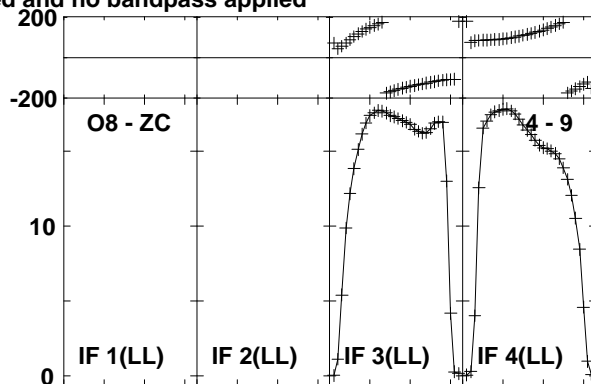
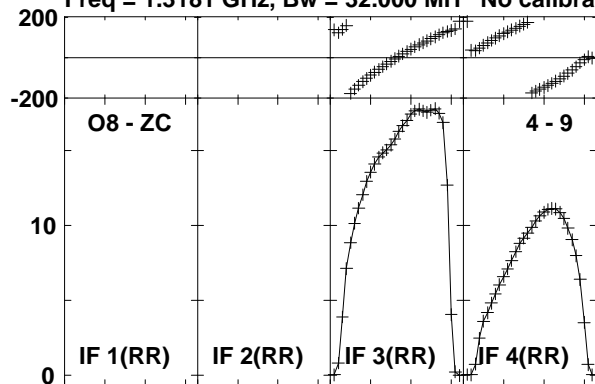

Lower frame: Milli Ampl Jy Top frame: Phas deg
 Vector averaged cross-power spectrum Baseline: O8 (04) - ZC (09)
 Timerange: 00/07:33:23 to 00/07:43:19

Plot file version 84 created 20-NOV-2015 13:43:55

3C84 EO013 1.UVDATA.1

Freq = 1.3181 GHz, Bw = 32.000 MH No calibration applied and no bandpass applied

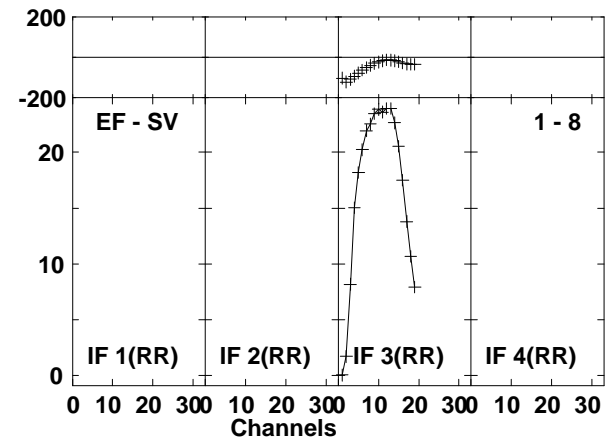
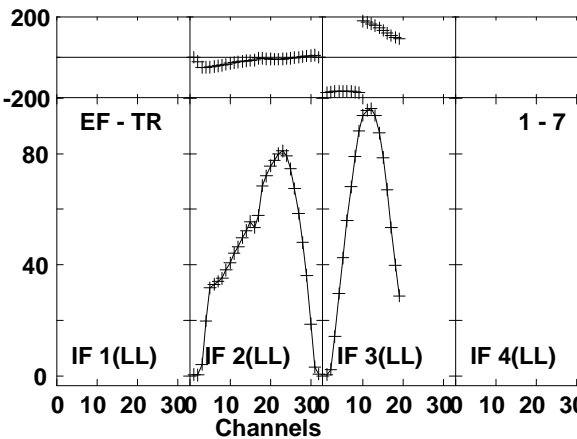
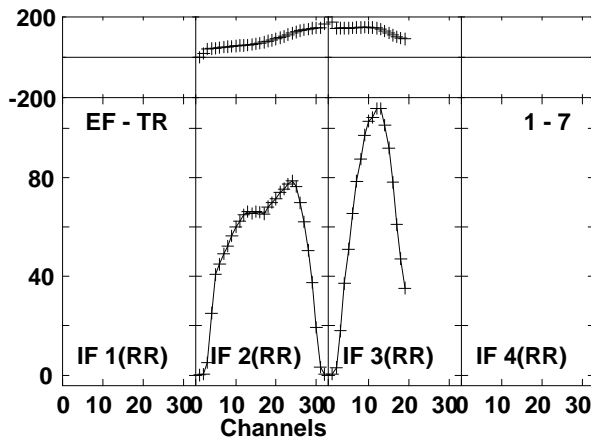
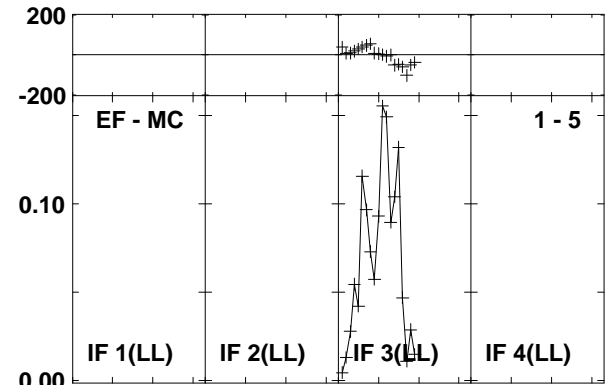
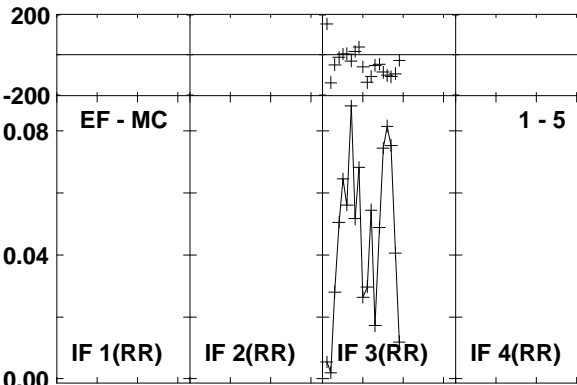
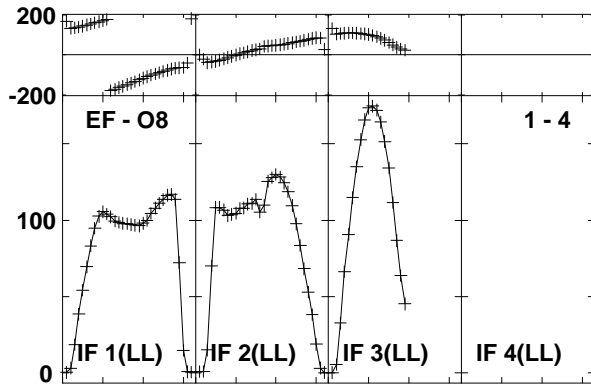
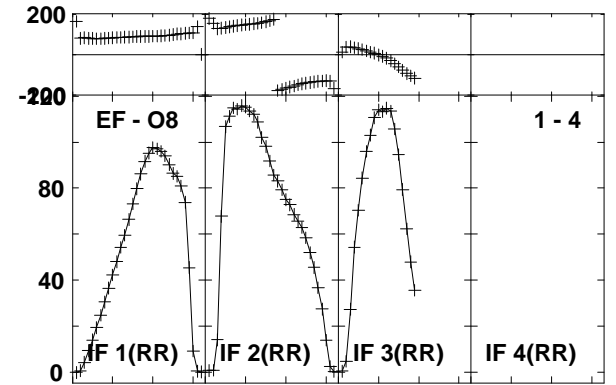
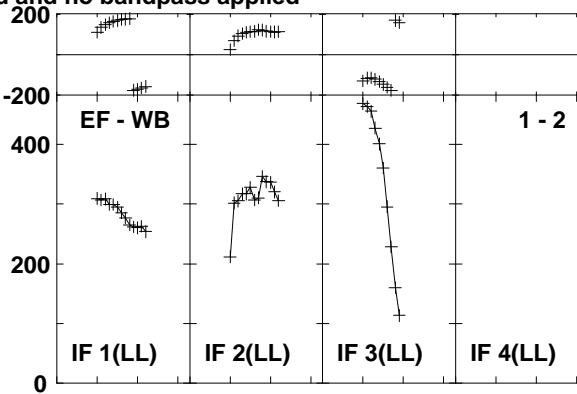
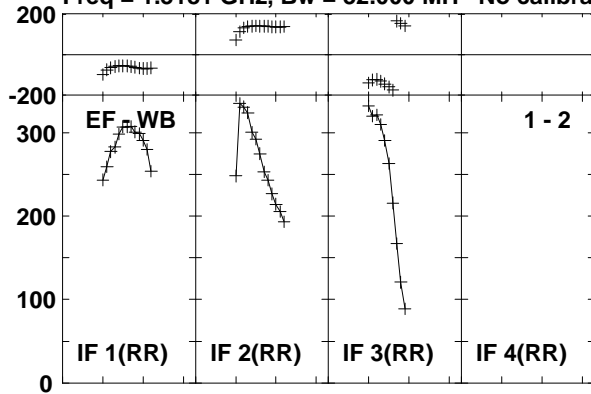

Lower frame: Milli Ampl Jy Top frame: Phas deg
Vector averaged cross-power spectrum Baseline: EF (01) - WB (02)
Timerange: 00/07:43:53 to 00/07:53:49

Plot file version 85 created 20-NOV-2015 13:43:55
 3C84 EO013 1.UVDATA.1
 Freq = 1.3181 GHz, Bw = 32.000 MH No calibration applied and no bandpass applied

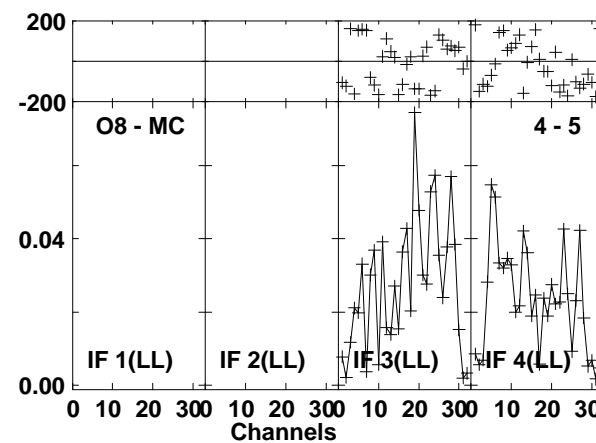
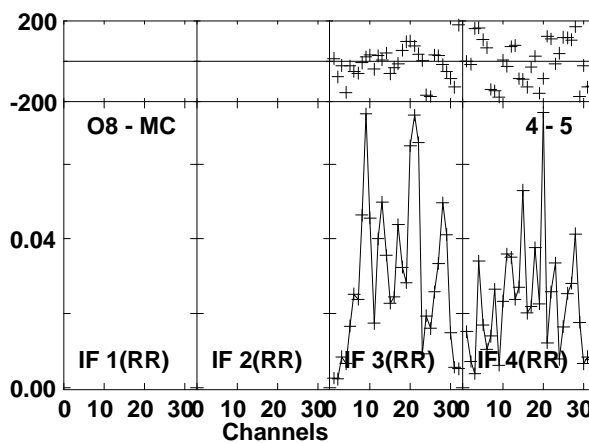
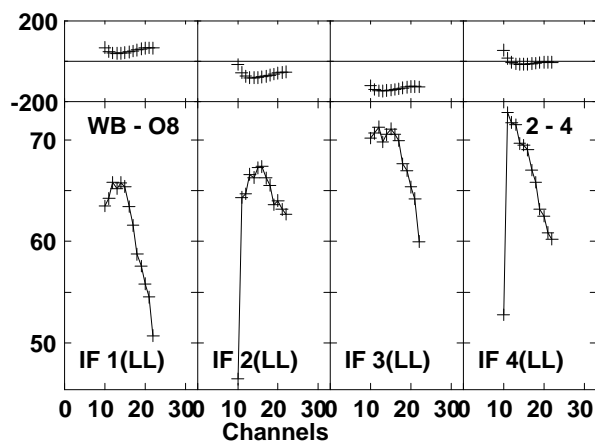
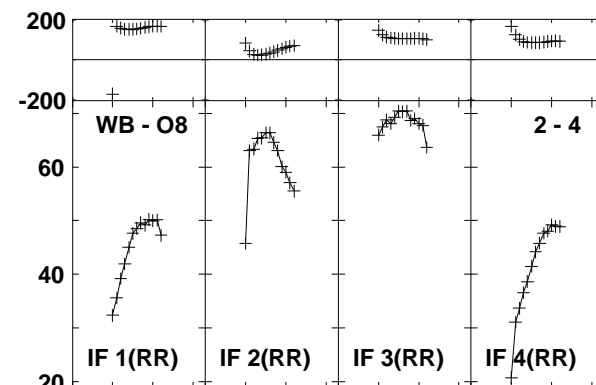
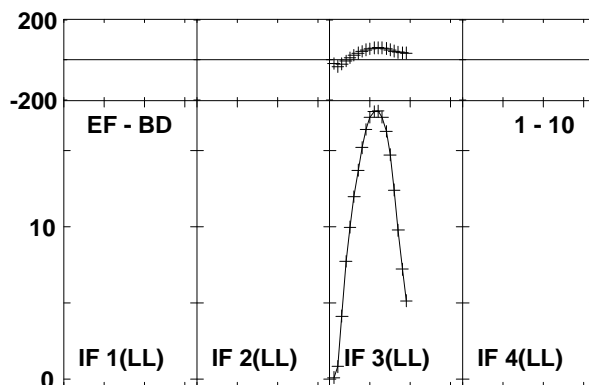
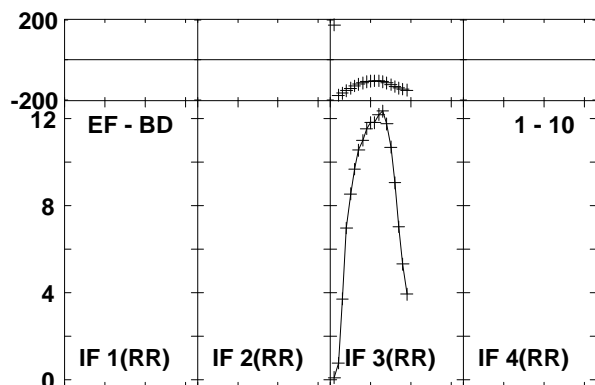
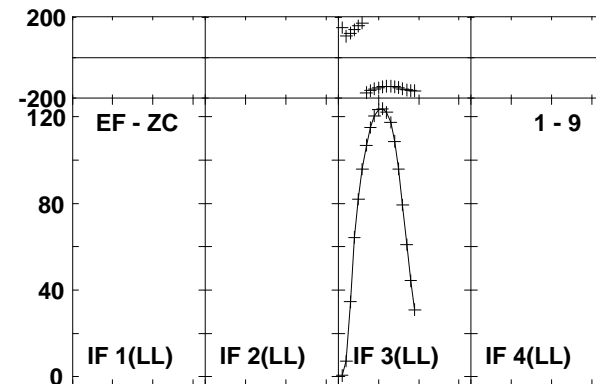
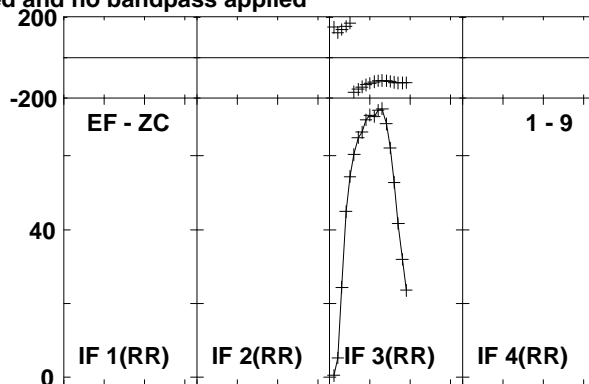
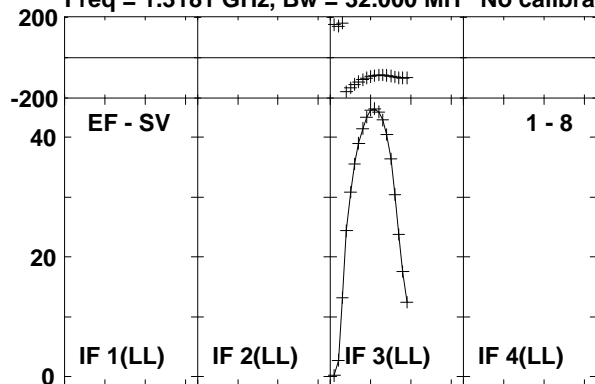

Lower frame: Milli Ampl Jy Top frame: Phas deg
 Vector averaged cross-power spectrum Baseline: EF (01) - SV (08)
 Timerange: 00/07:43:53 to 00/07:53:49

Plot file version 86 created 20-NOV-2015 13:43:55
 3C84 EO013 1.UVDATA.1
 Freq = 1.3181 GHz, Bw = 32.000 MH No calibration applied and no bandpass applied

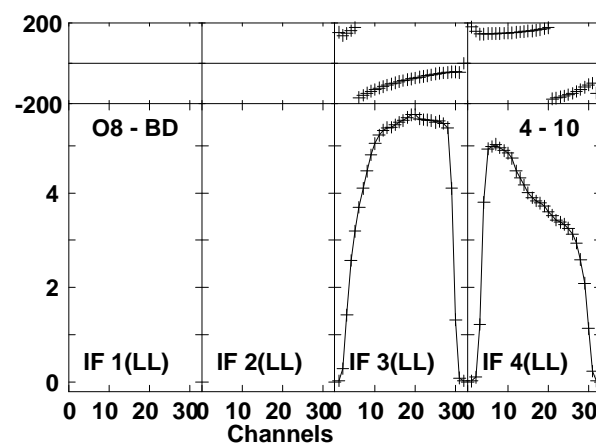
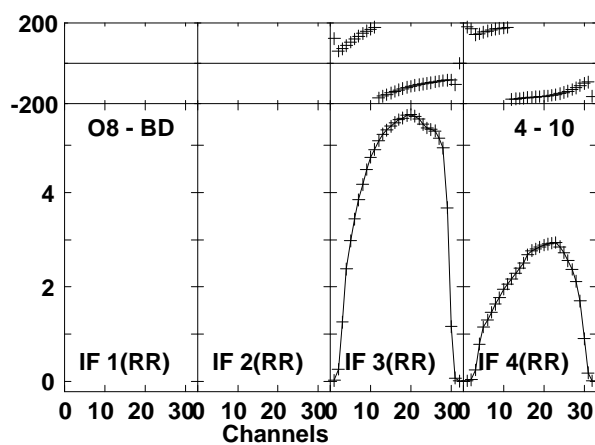
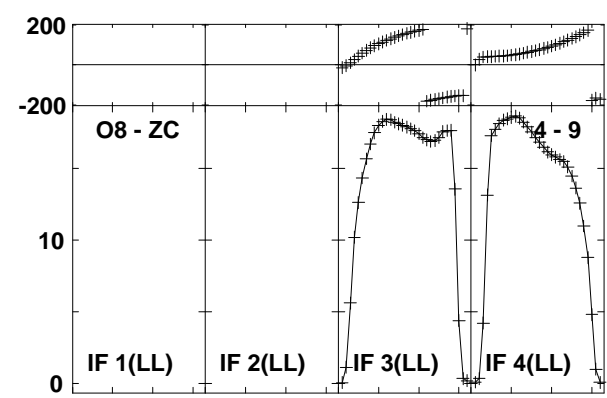
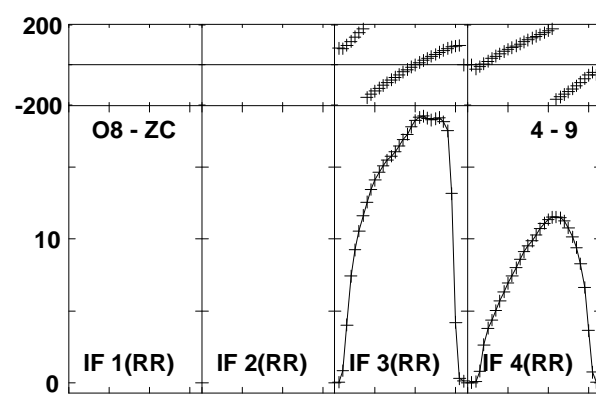
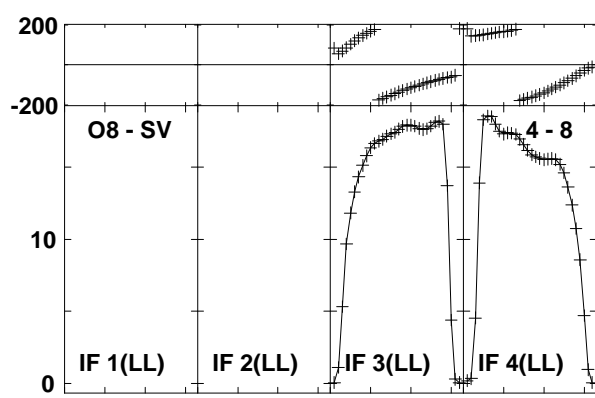
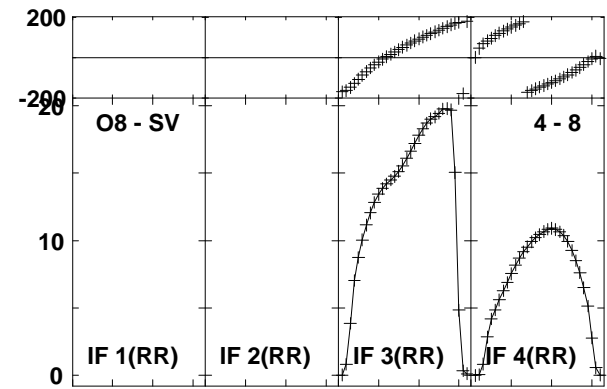
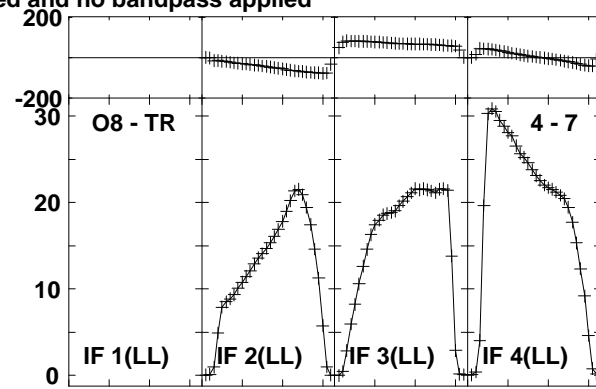
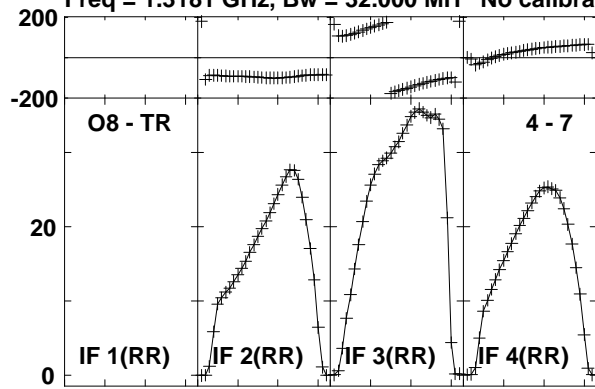

Lower frame: Milli Ampl Jy Top frame: Phas deg
 Vector averaged cross-power spectrum Baseline: O8 (04) - TR (07)
 Timerange: 00/07:43:53 to 00/07:53:49

Plot file version 87 created 20-NOV-2015 13:43:55

3C84 EO013 1.UVDATA.1

Freq = 1.3181 GHz, Bw = 32.000 MH No calibration applied and no bandpass applied

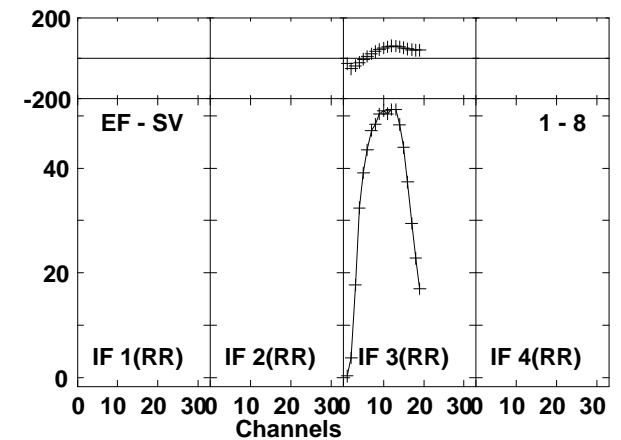
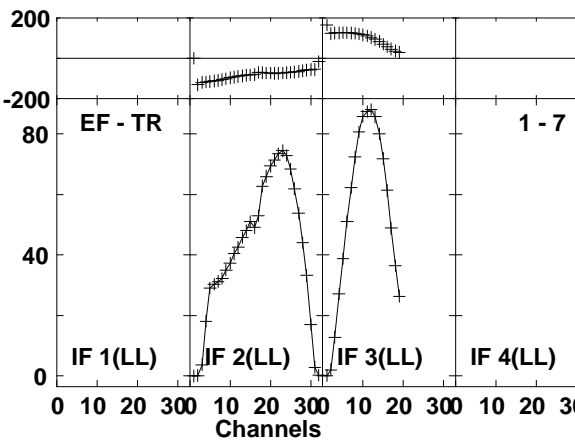
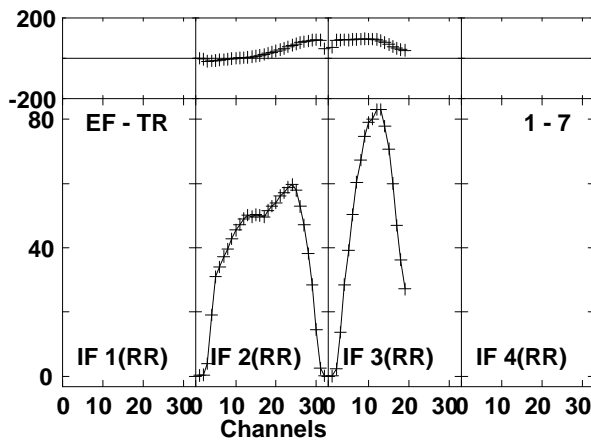
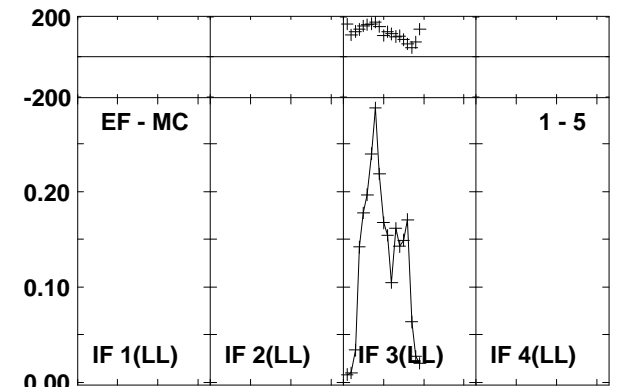
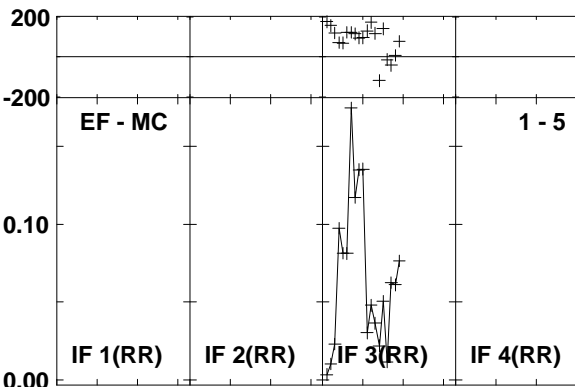
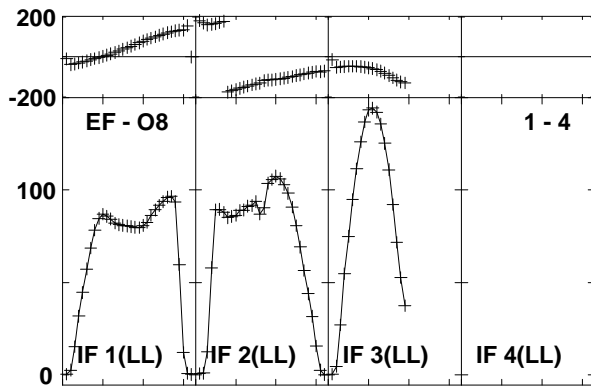
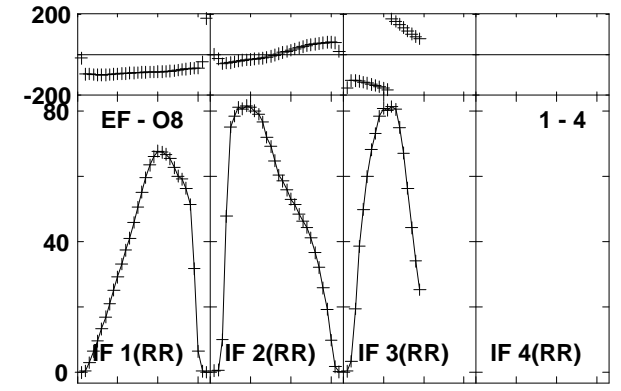
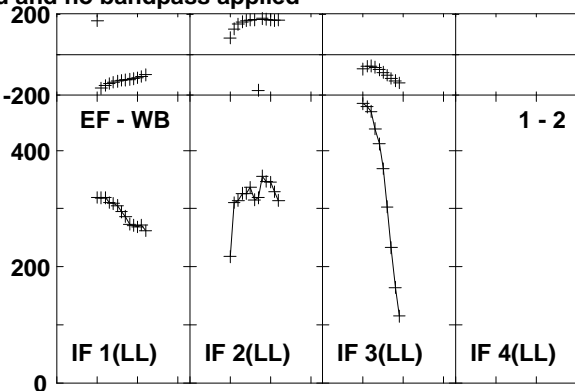
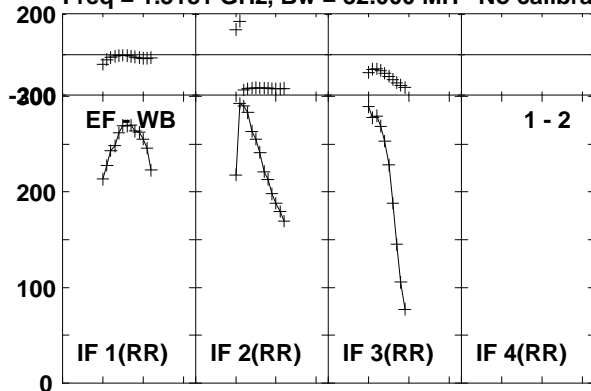

Lower frame: Milli Ampl Jy Top frame: Phas deg
Vector averaged cross-power spectrum Baseline: EF (01) - WB (02)
Timerange: 00/07:54:23 to 00/08:04:19

Plot file version 88 created 20-NOV-2015 13:43:55
 3C84 EO013 1.UVDATA.1
 Freq = 1.3181 GHz, Bw = 32.000 MH No calibration applied and no bandpass applied

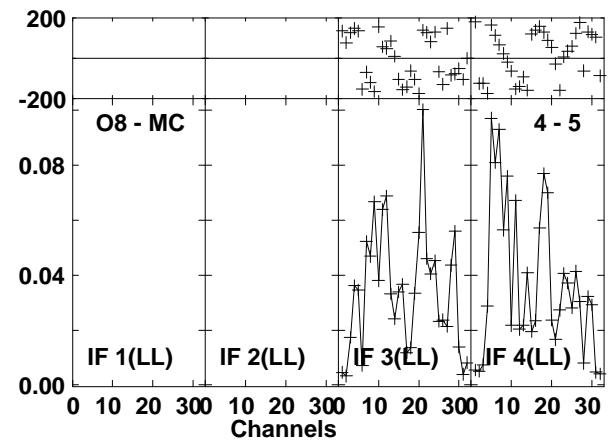
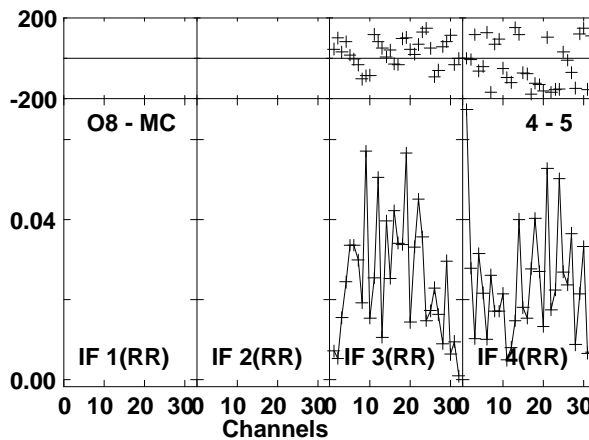
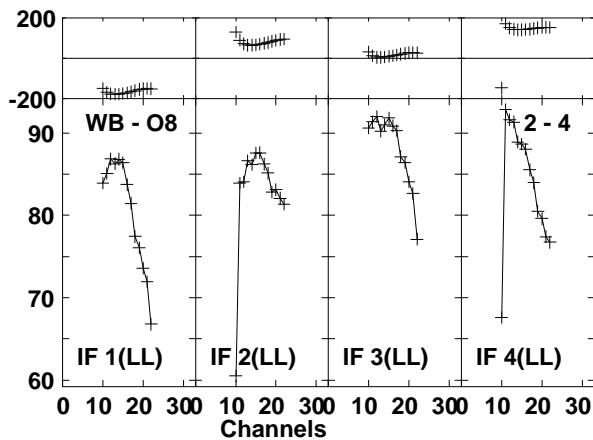
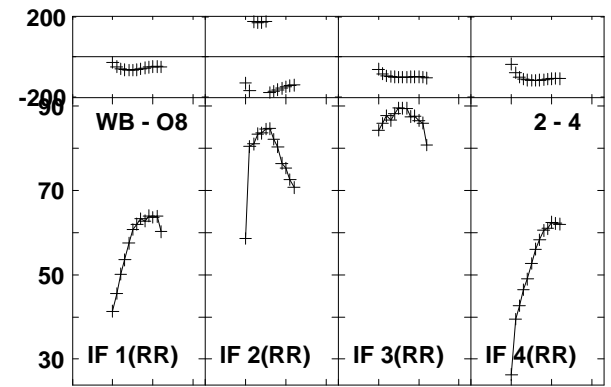
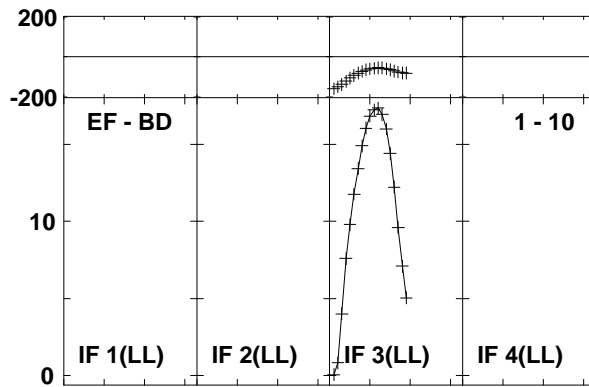
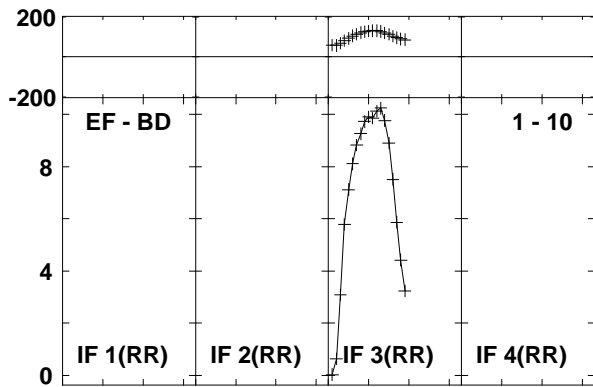
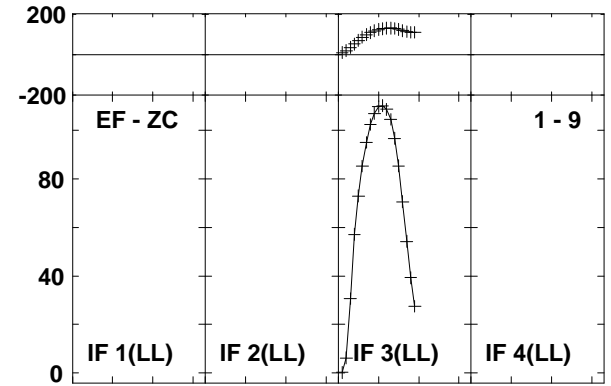
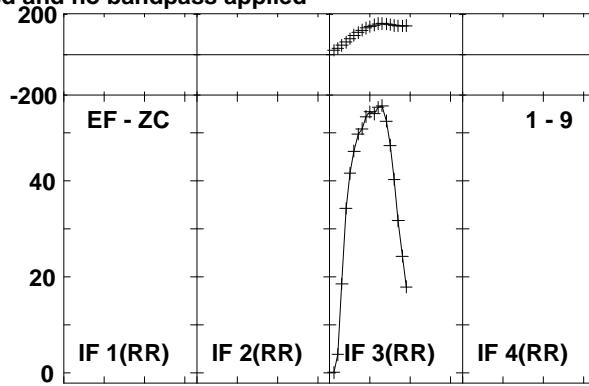
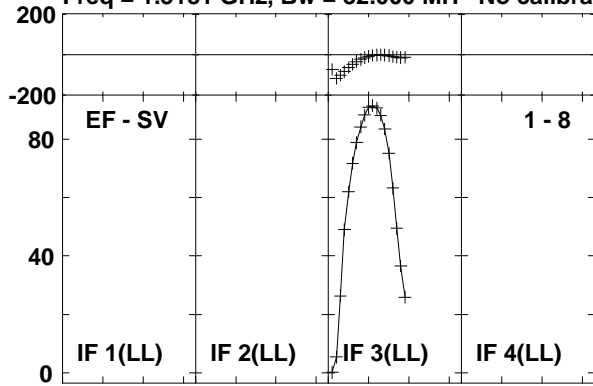

Lower frame: Milli Ampl Jy Top frame: Phas deg
 Vector averaged cross-power spectrum Baseline: EF (01) - SV (08)
 Timerange: 00/07:54:23 to 00/08:04:19

Plot file version 89 created 20-NOV-2015 13:43:55
 3C84 EO013 1.UVDATA.1
 Freq = 1.3181 GHz, Bw = 32.000 MH No calibration applied and no bandpass applied

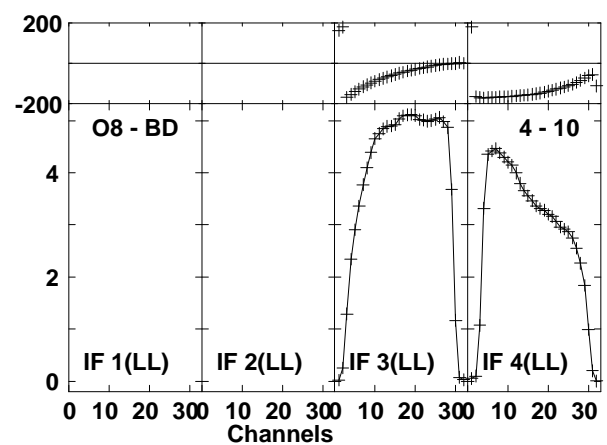
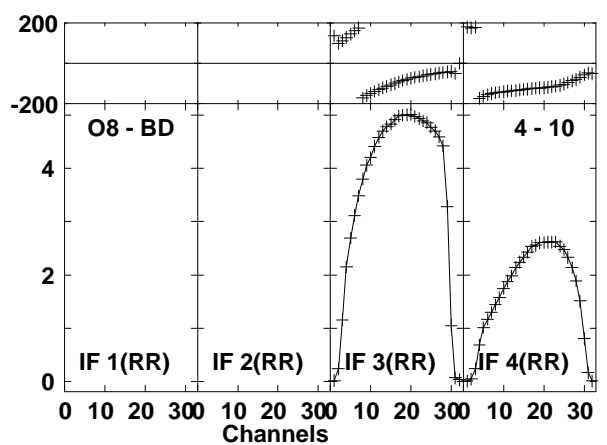
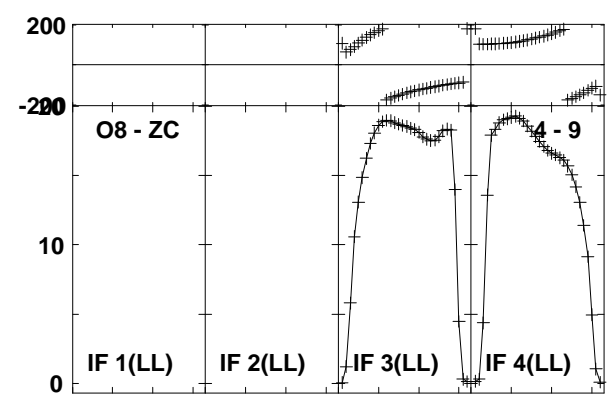
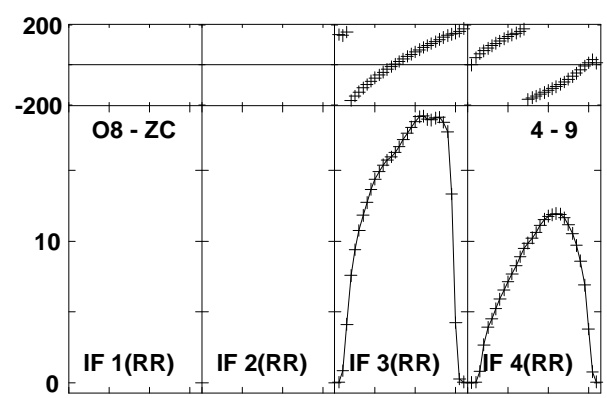
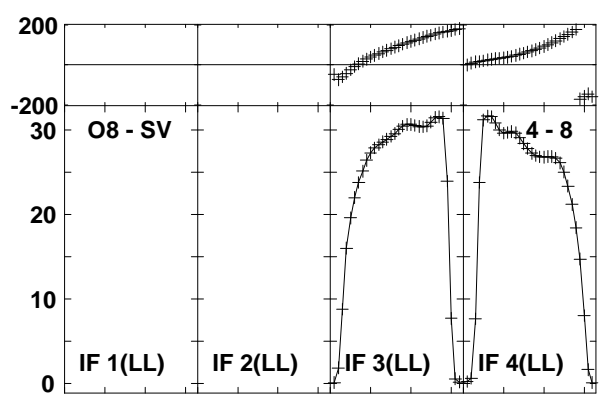
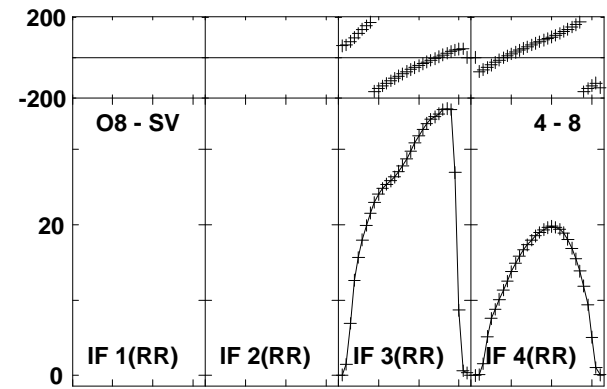
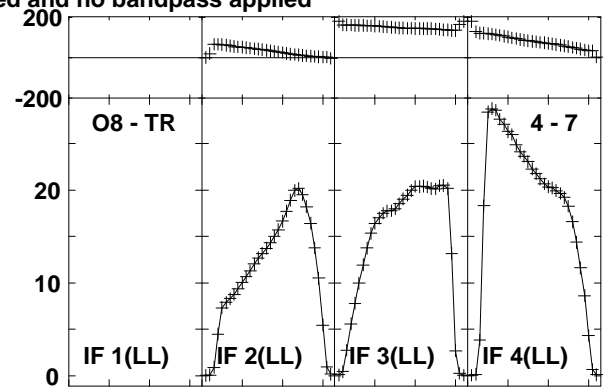
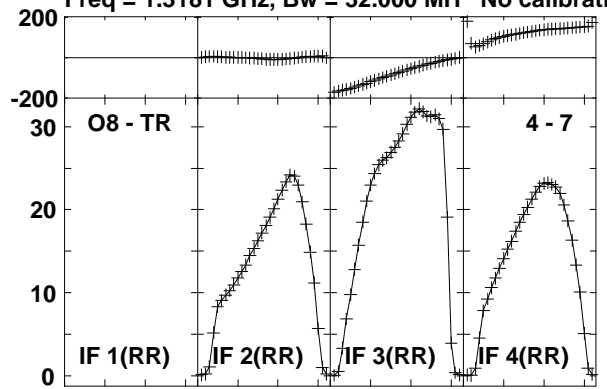

Lower frame: Milli Ampl Jy Top frame: Phas deg
 Vector averaged cross-power spectrum Baseline: O8 (04) - TR (07)
 Timerange: 00/07:54:23 to 00/08:04:19

Plot file version 90 created 20-NOV-2015 13:43:55

3C84 EO013 1.UVDATA.1

Freq = 1.3181 GHz, Bw = 32.000 MH No calibration applied and no bandpass applied

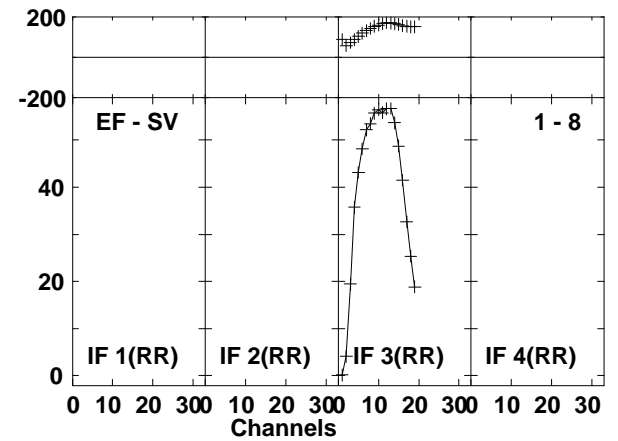
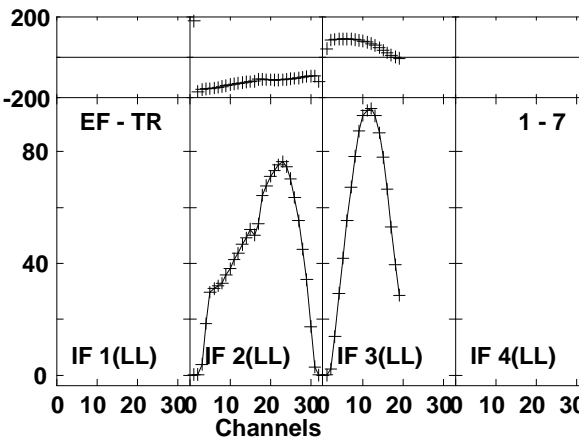
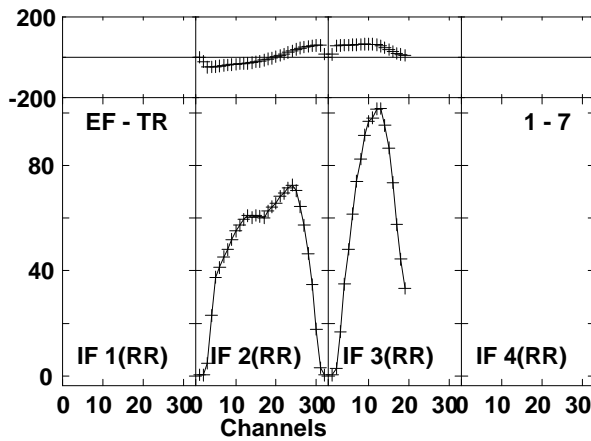
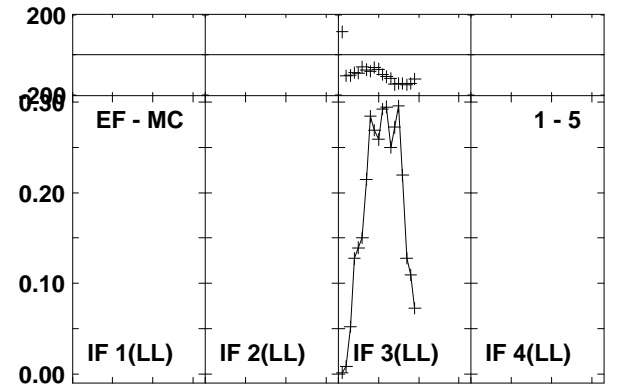
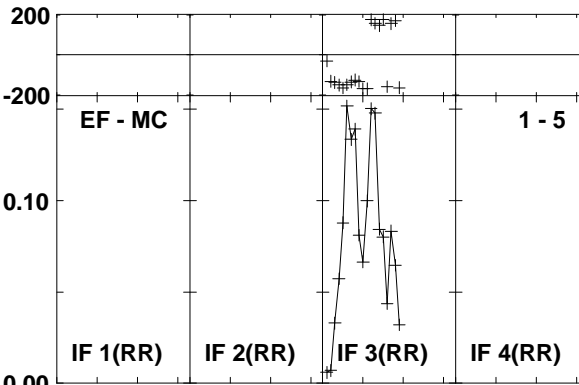
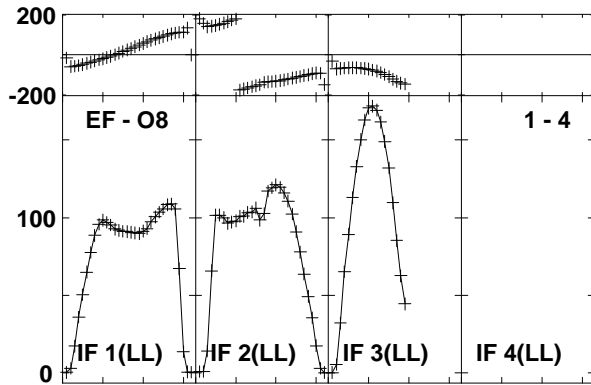
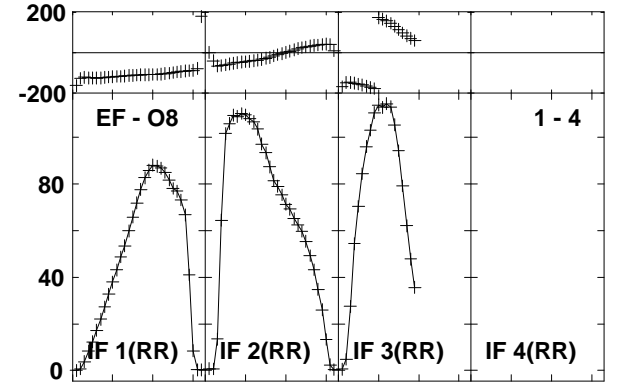
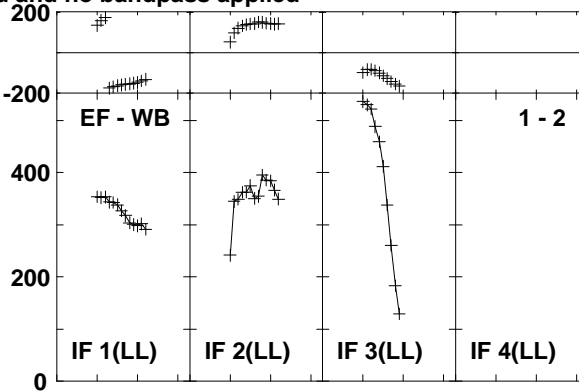
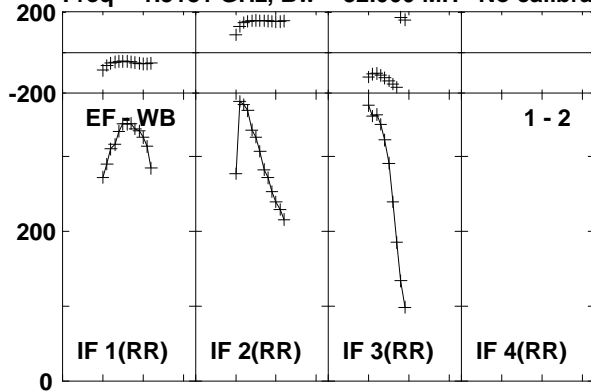

Lower frame: Milli Ampl Jy Top frame: Phas deg
Vector averaged cross-power spectrum Baseline: EF (01) - WB (02)
Timerange: 00/08:04:53 to 00/08:14:49

Plot file version 91 created 20-NOV-2015 13:43:55
 3C84 EO013 1.UVDATA.1
 Freq = 1.3181 GHz, Bw = 32.000 MH No calibration applied and no bandpass applied

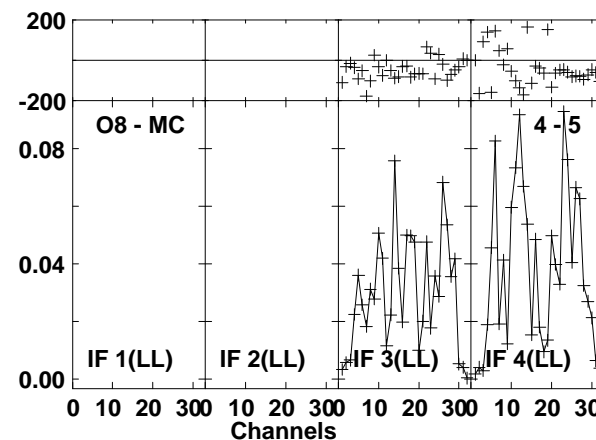
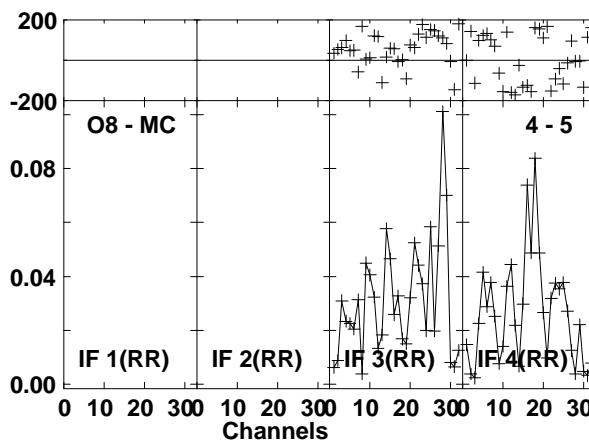
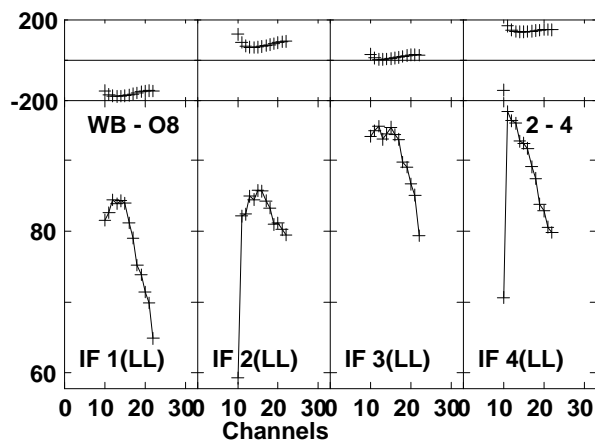
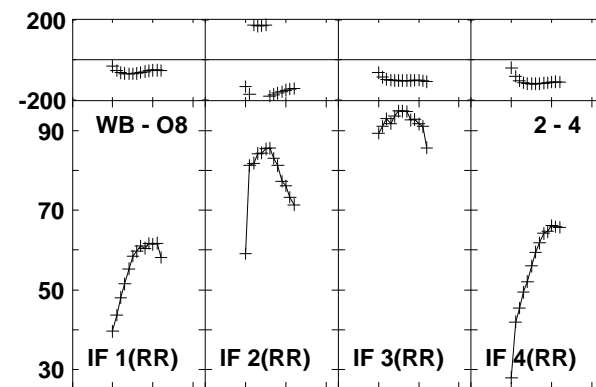
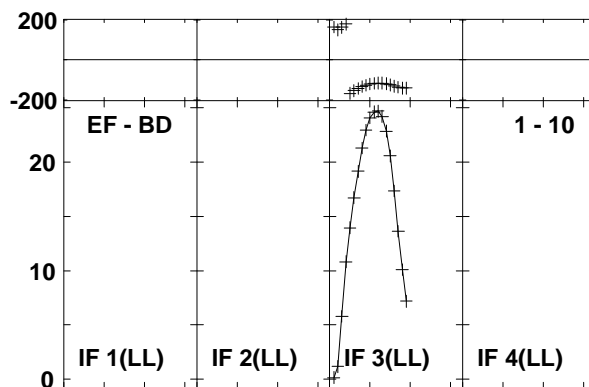
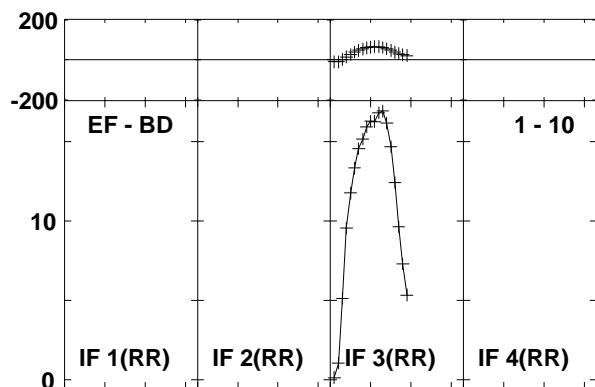
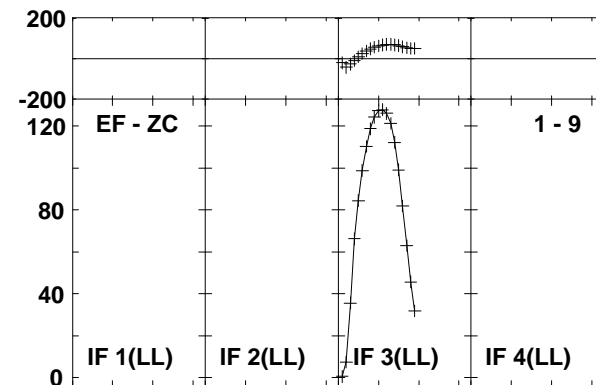
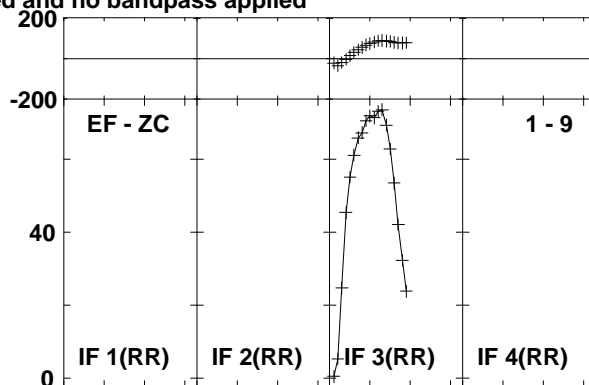
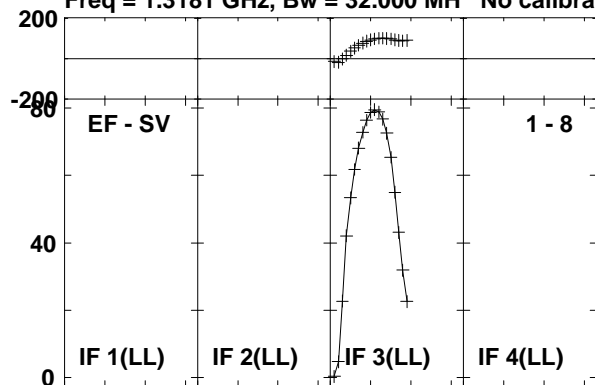

Lower frame: Milli Ampl Jy Top frame: Phas deg
 Vector averaged cross-power spectrum Baseline: EF (01) - SV (08)
 Timerange: 00/08:04:53 to 00/08:14:49

Plot file version 92 created 20-NOV-2015 13:43:56
 3C84 EO013 1.UVDATA.1
 Freq = 1.3181 GHz, Bw = 32.000 MH No calibration applied and no bandpass applied

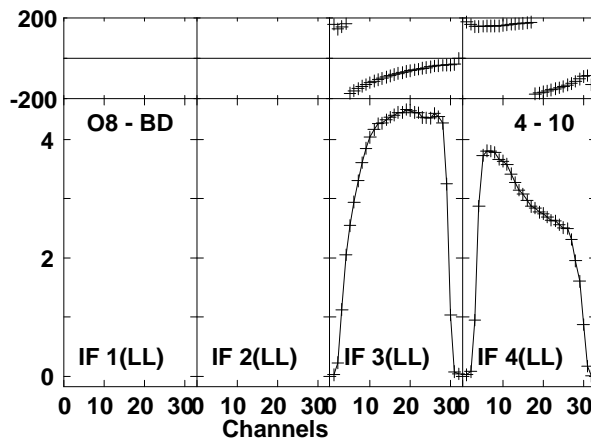
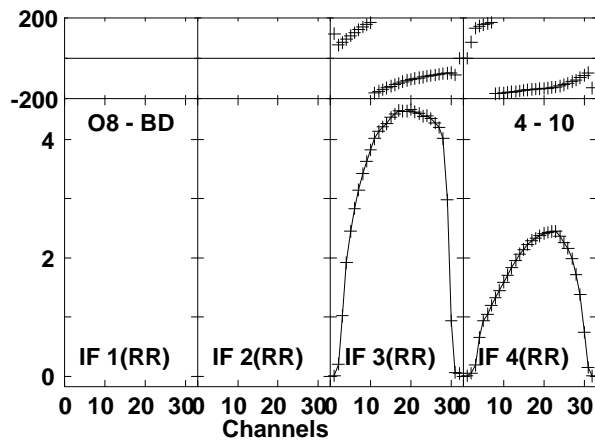
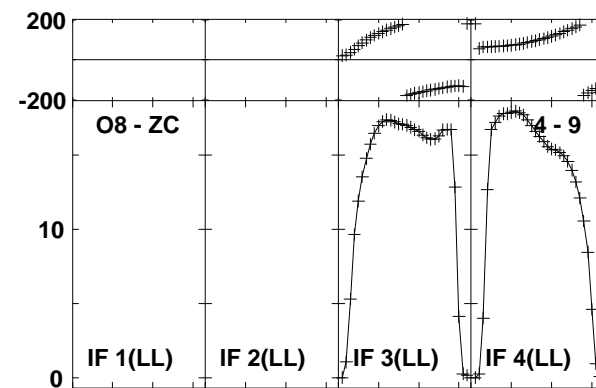
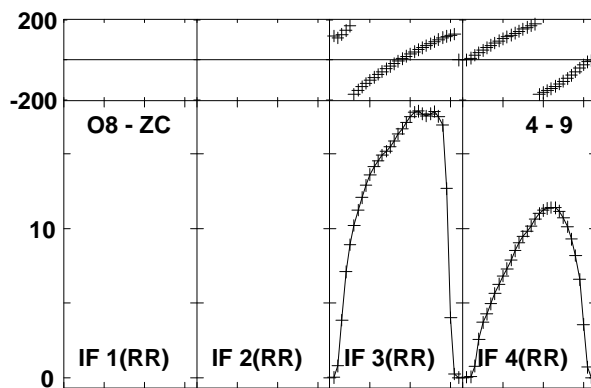
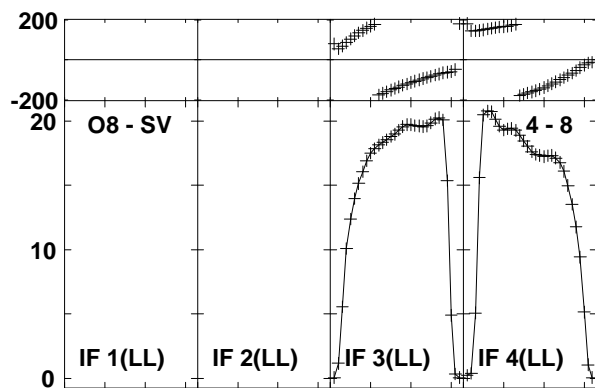
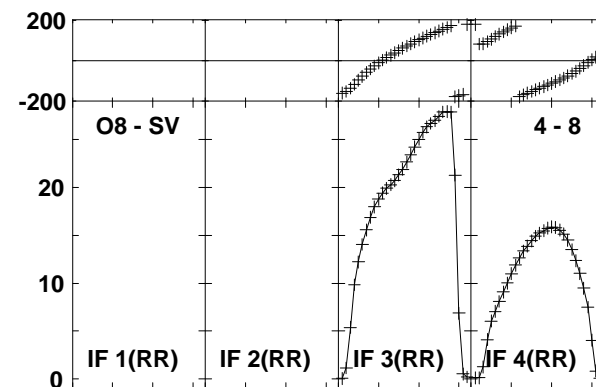
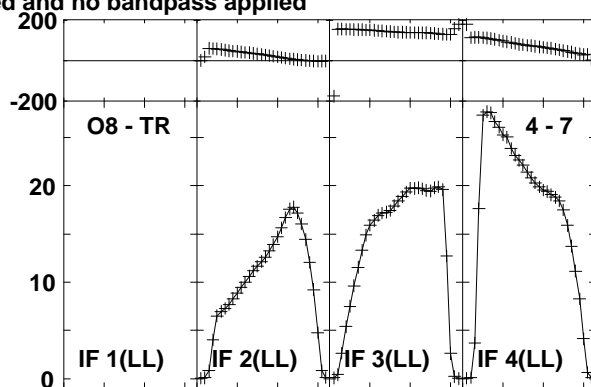
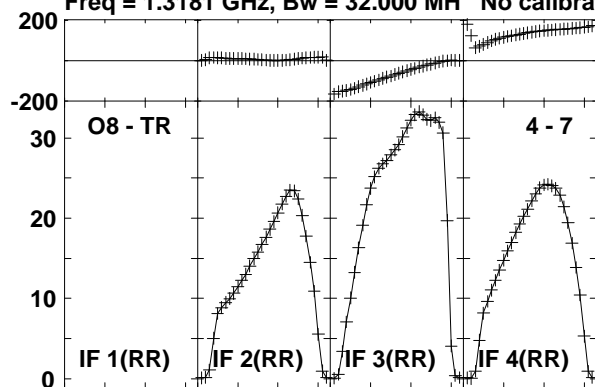

Lower frame: Milli Ampl Jy Top frame: Phas deg
 Vector averaged cross-power spectrum Baseline: O8 (04) - TR (07)
 Timerange: 00/08:04:53 to 00/08:14:49

Plot file version 93 created 20-NOV-2015 13:43:56

DA193 EO13 1.UVDATA.1

Freq = 1.3181 GHz, Bw = 32.000 MH No calibration applied and no bandpass applied

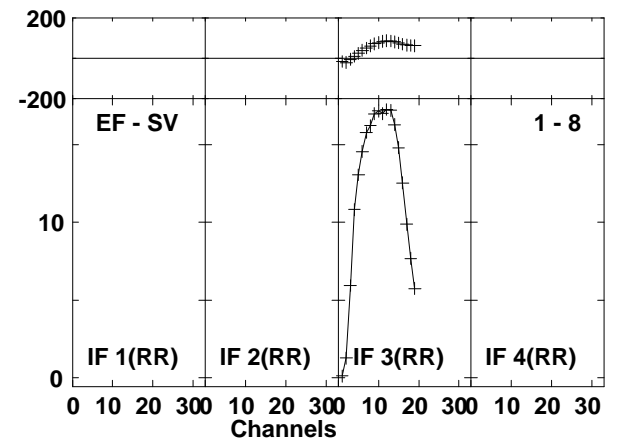
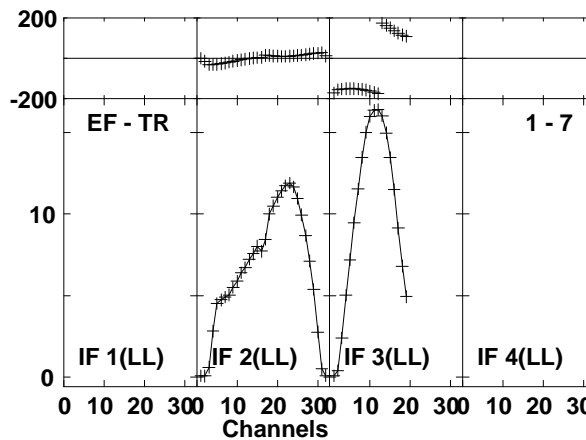
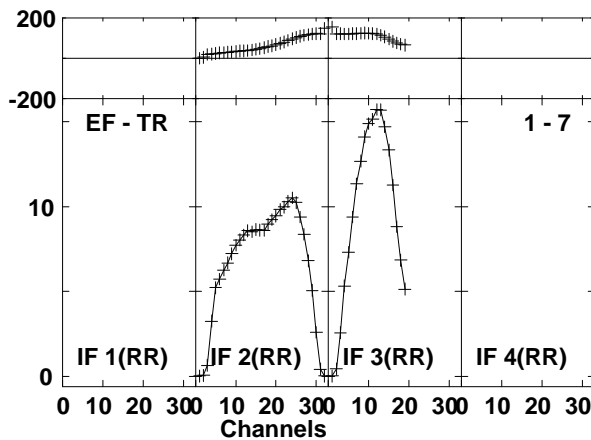
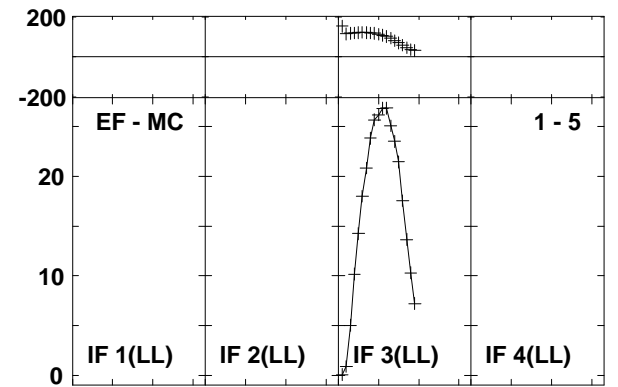
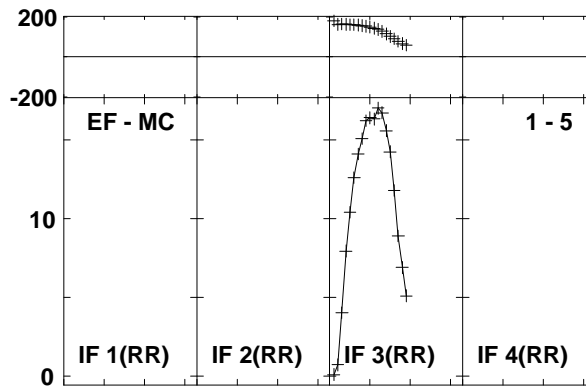
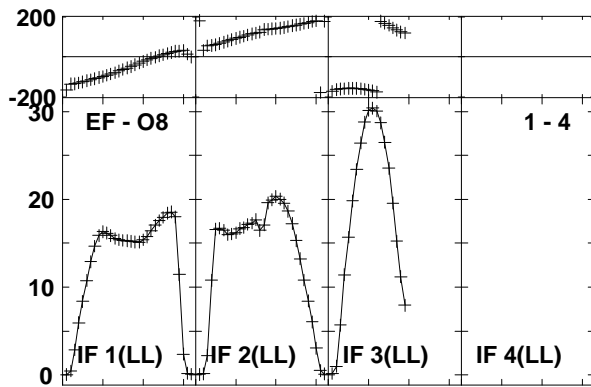
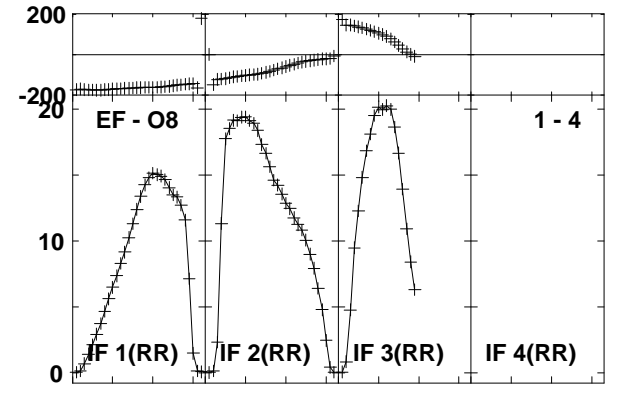
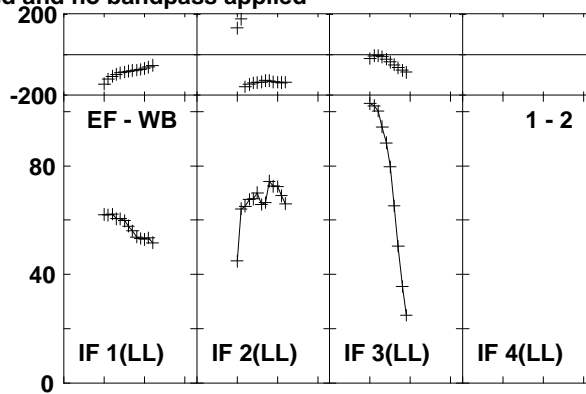
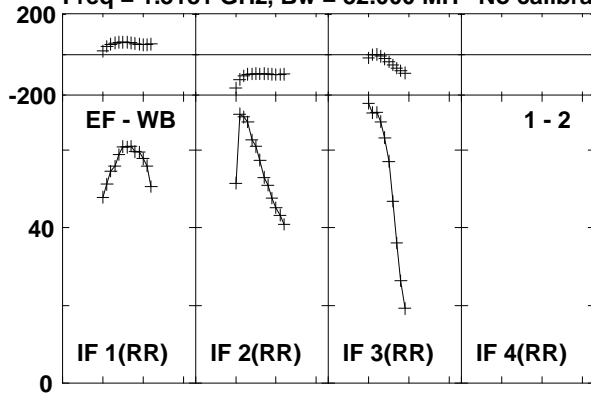

Lower frame: Milli Ampl Jy Top frame: Phas deg
Vector averaged cross-power spectrum Baseline: EF (01) - WB (02)
Timerange: 00/08:18:03 to 00/08:27:59

Plot file version 94 created 20-NOV-2015 13:43:56

DA193 EO013 1.UVDATA.1

Freq = 1.3181 GHz, Bw = 32.000 MH No calibration applied and no bandpass applied

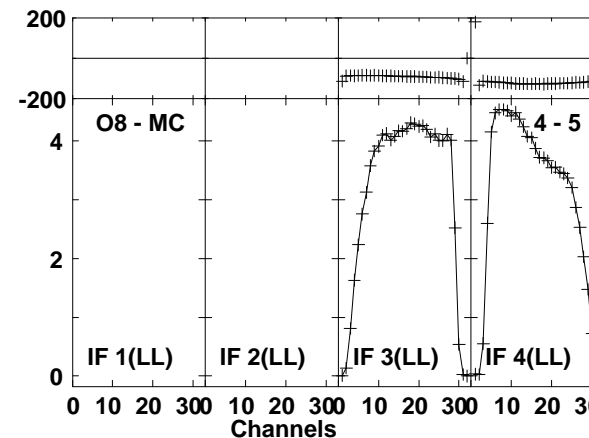
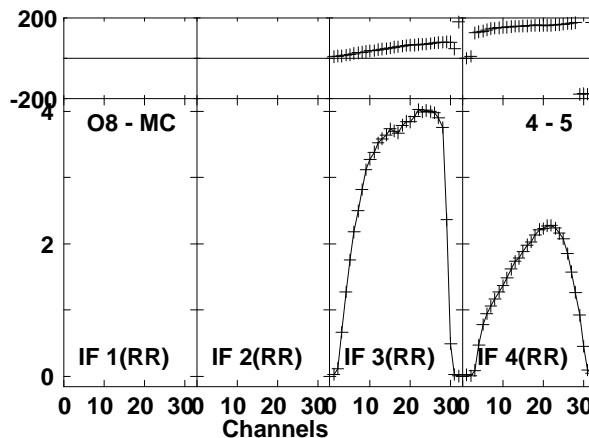
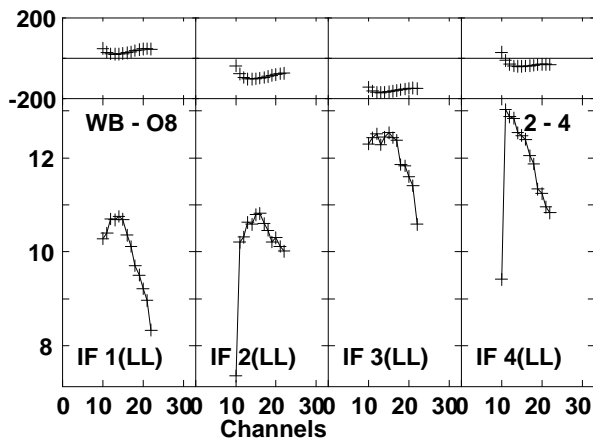
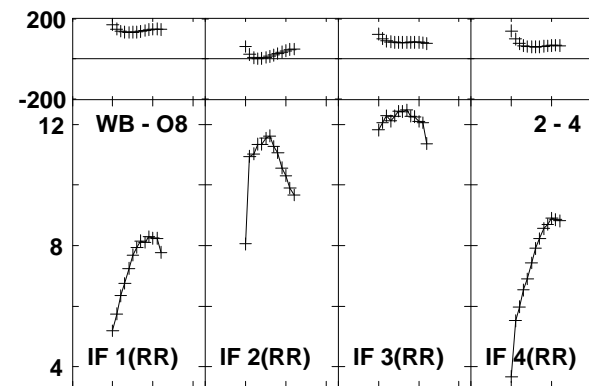
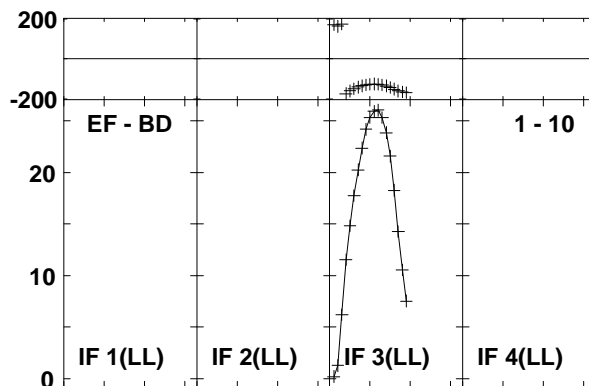
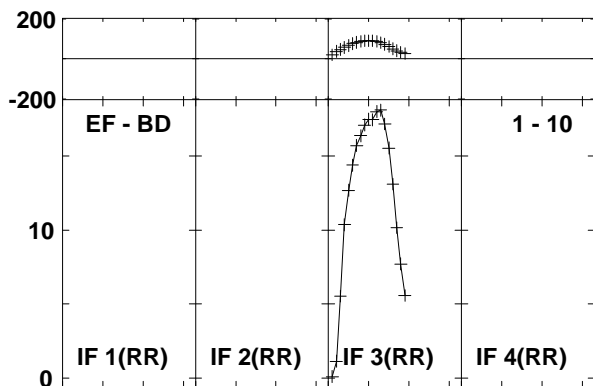
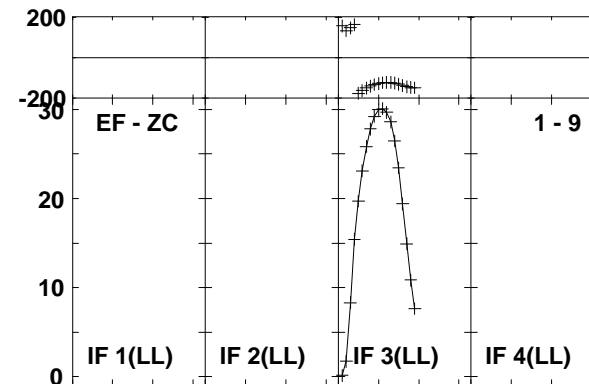
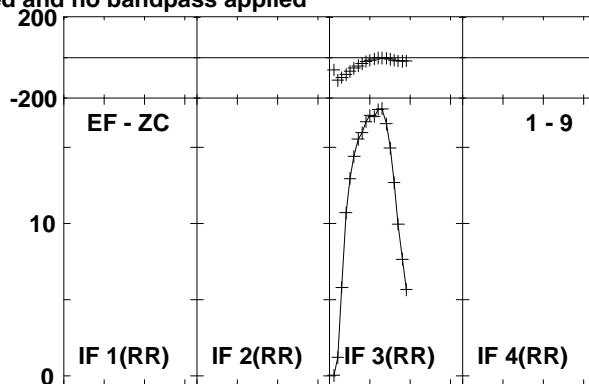
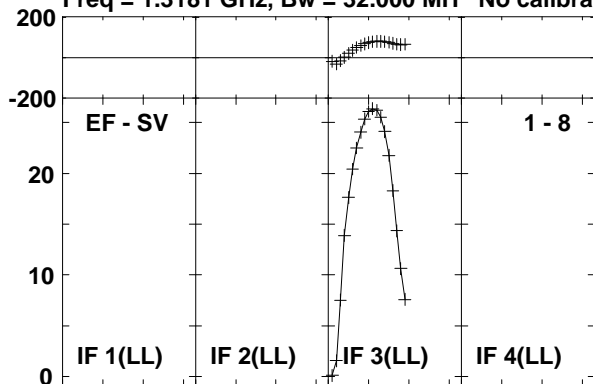

Lower frame: Milli Ampl Jy Top frame: Phas deg
Vector averaged cross-power spectrum Baseline: EF (01) - SV (08)
Timerange: 00/08:18:03 to 00/08:27:59

Plot file version 95 created 20-NOV-2015 13:43:56

DA193 EO013 1.UVDATA.1

Freq = 1.3181 GHz, Bw = 32.000 MH No calibration applied and no bandpass applied

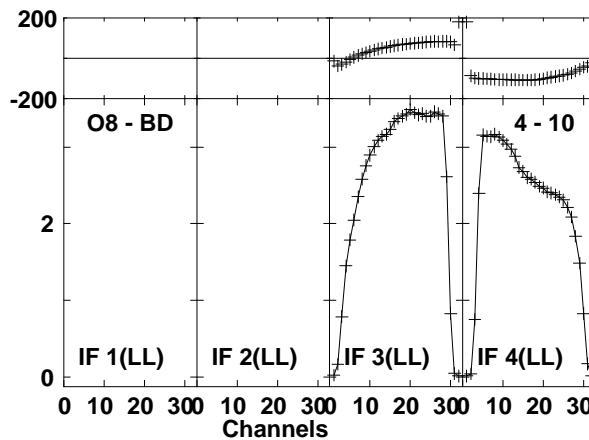
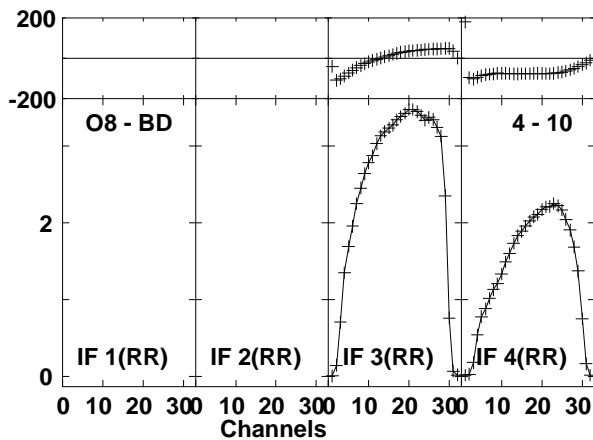
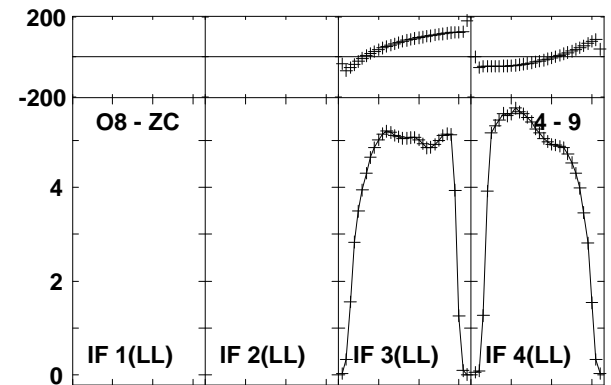
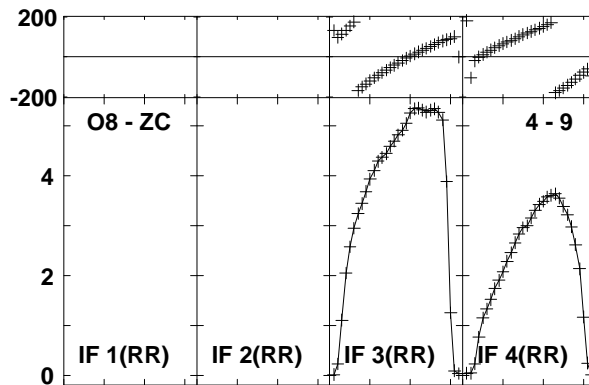
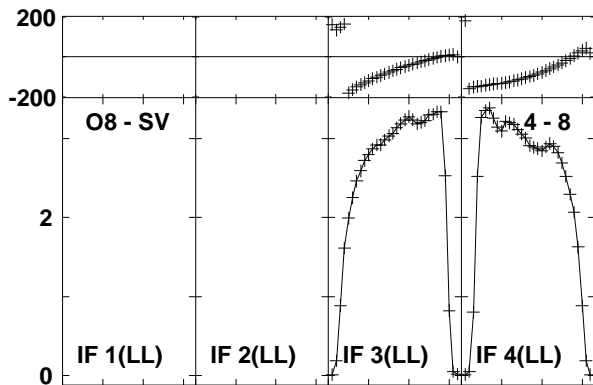
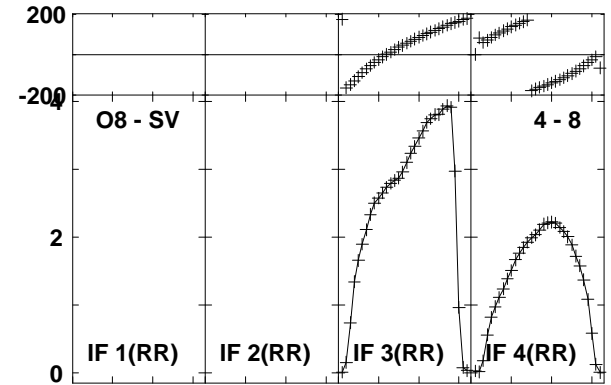
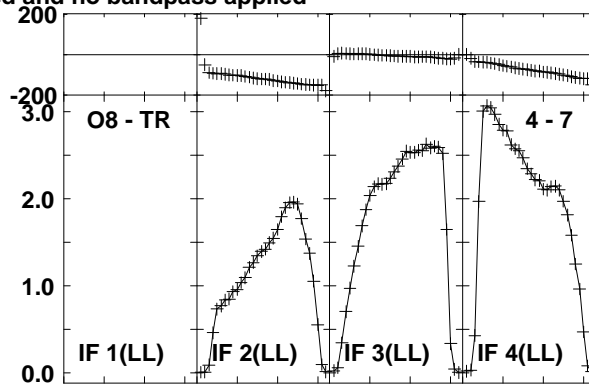
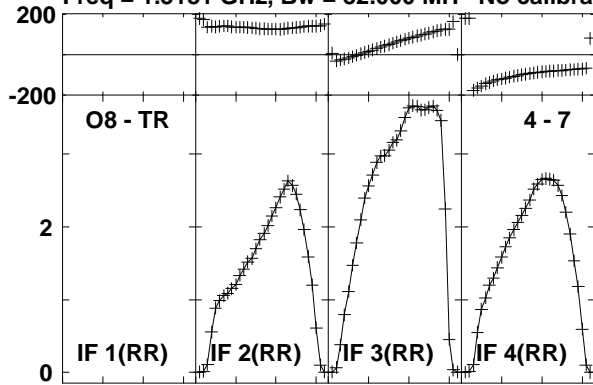

Lower frame: Milli Ampl Jy Top frame: Phas deg

Vector averaged cross-power spectrum Baseline: O8 (04) - TR (07)

Timerange: 00/08:18:03 to 00/08:27:59

Plot file version 96 created 20-NOV-2015 13:43:56

DA193 EO13 1.UVDATA.1

Freq = 1.3181 GHz, Bw = 32.000 MH No calibration applied and no bandpass applied

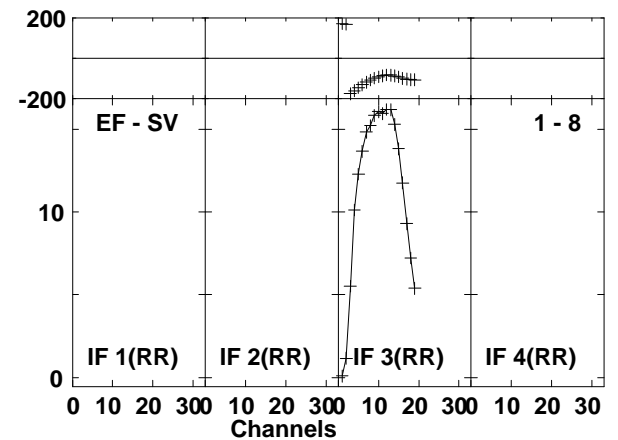
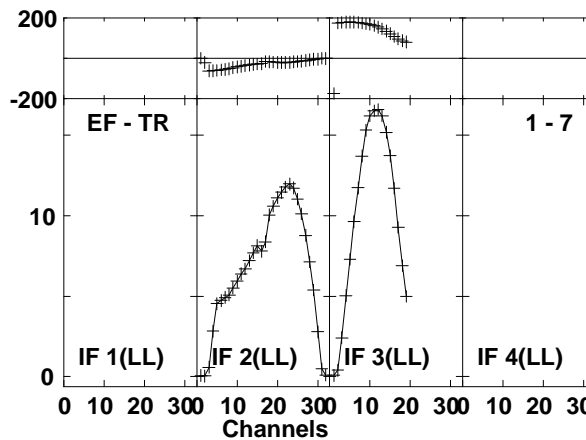
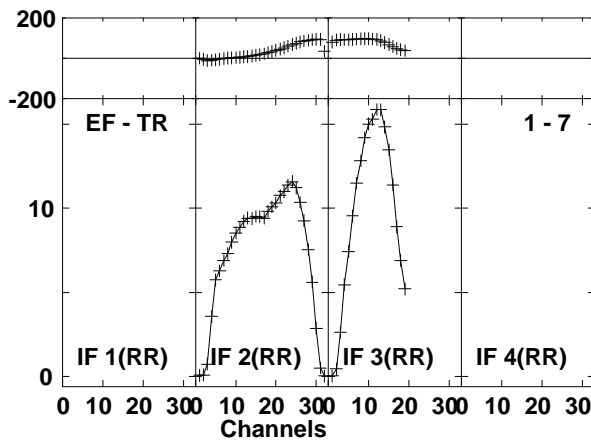
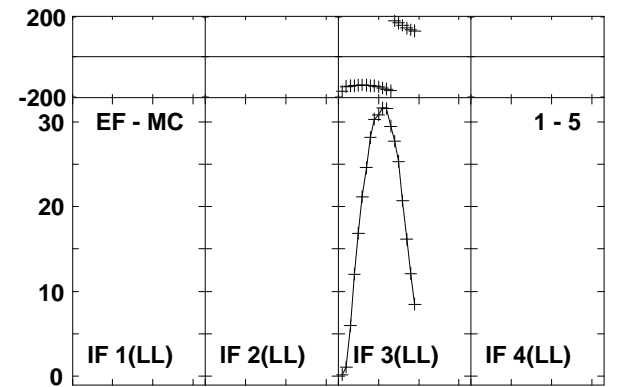
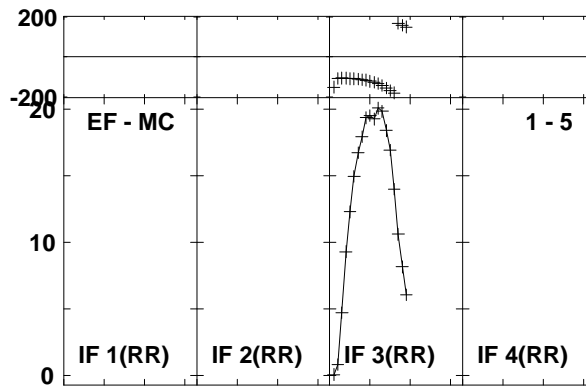
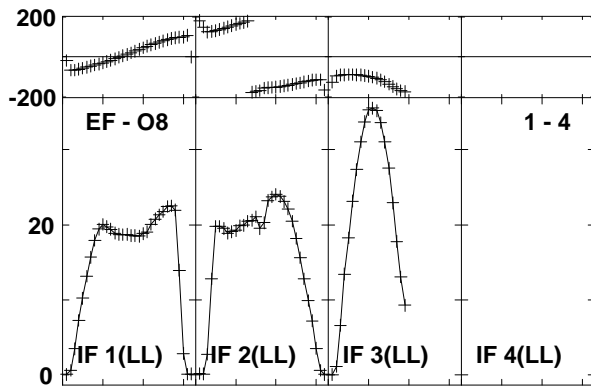
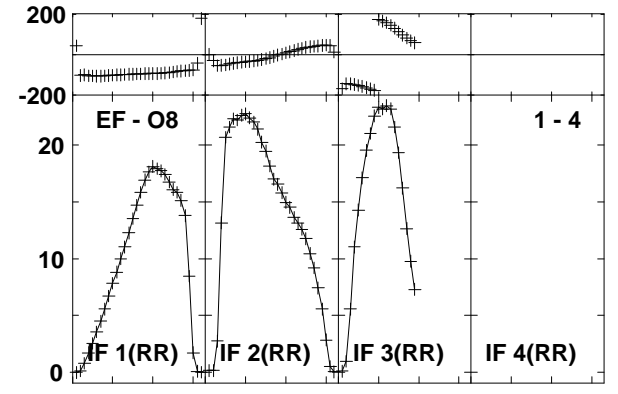
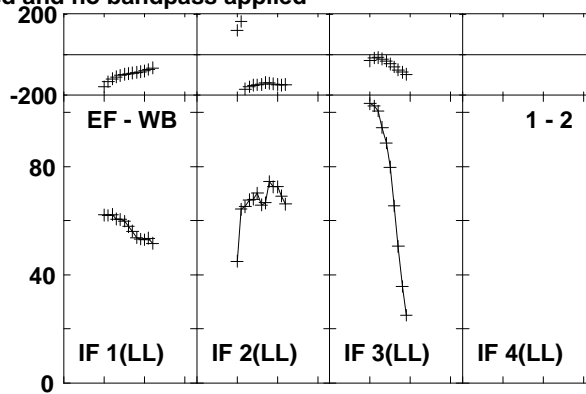
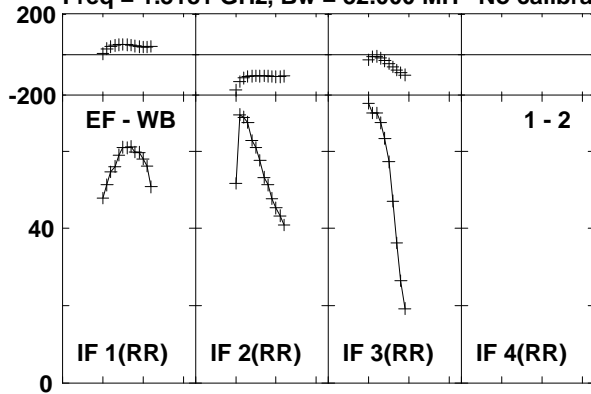

Lower frame: Milli Ampl Jy Top frame: Phas deg
Vector averaged cross-power spectrum Baseline: EF (01) - WB (02)
Timerange: 00/08:28:33 to 00/08:33:29

Plot file version 97 created 20-NOV-2015 13:43:56

DA193 EO013 1.UVDATA.1

Freq = 1.3181 GHz, Bw = 32.000 MH No calibration applied and no bandpass applied

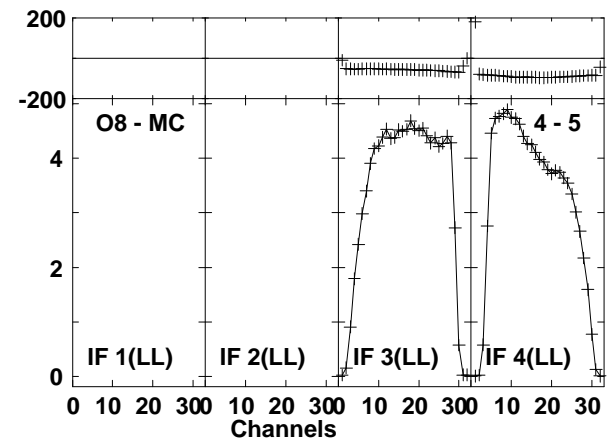
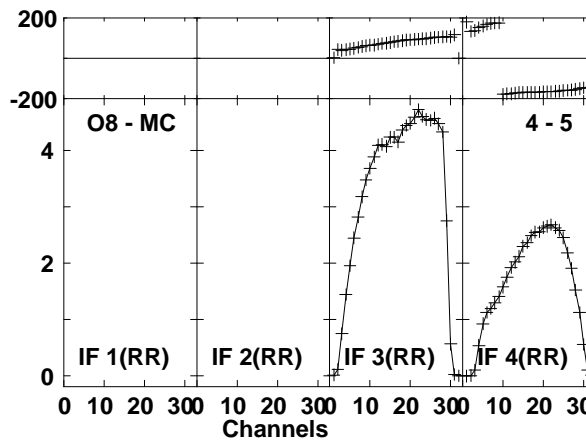
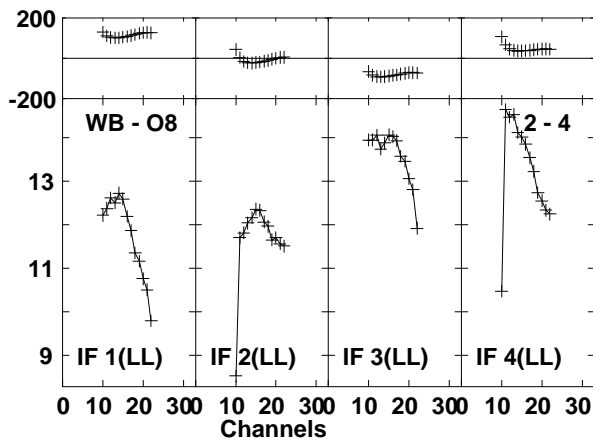
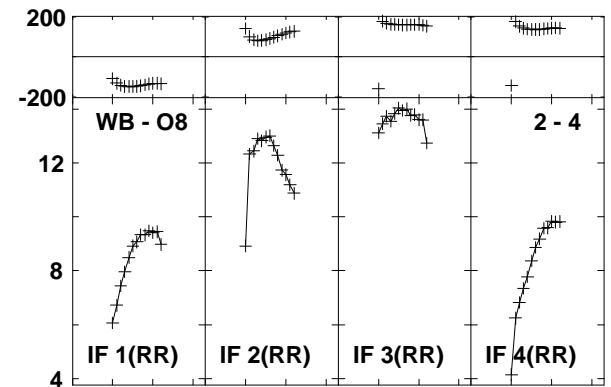
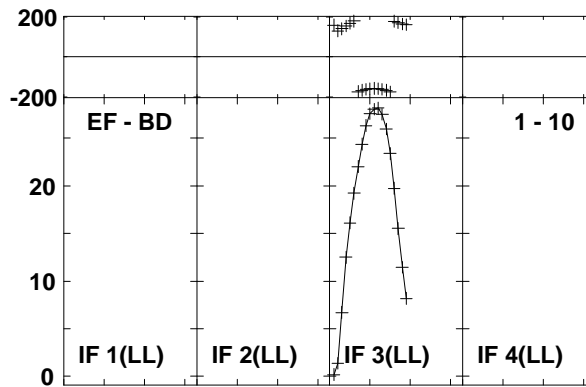
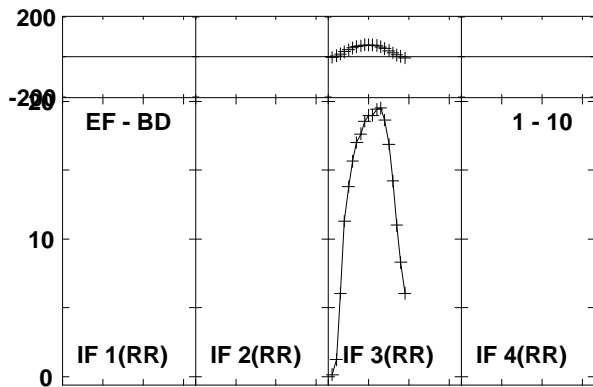
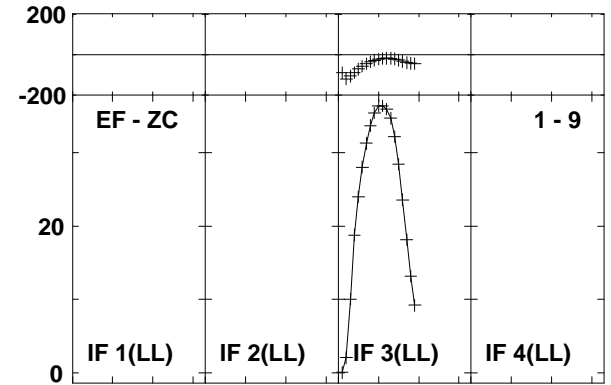
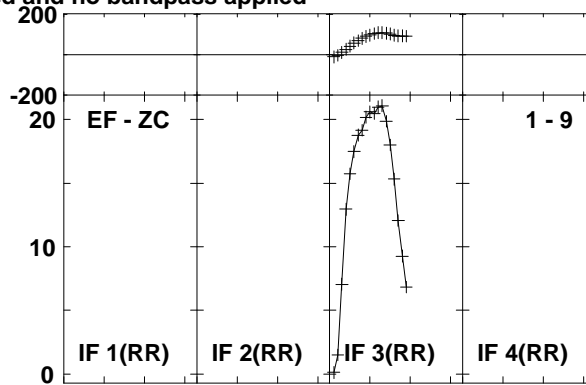
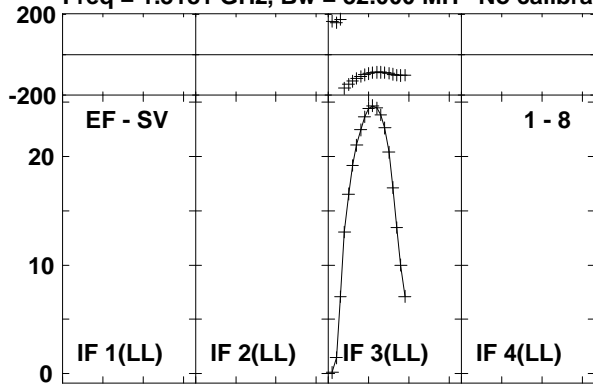

Lower frame: Milli Ampl Jy Top frame: Phas deg
Vector averaged cross-power spectrum Baseline: EF (01) - SV (08)
Timerange: 00/08:28:33 to 00/08:33:29

Plot file version 98 created 20-NOV-2015 13:43:56

DA193 EO013 1.UVDATA.1

Freq = 1.3181 GHz, Bw = 32.000 MH No calibration applied and no bandpass applied

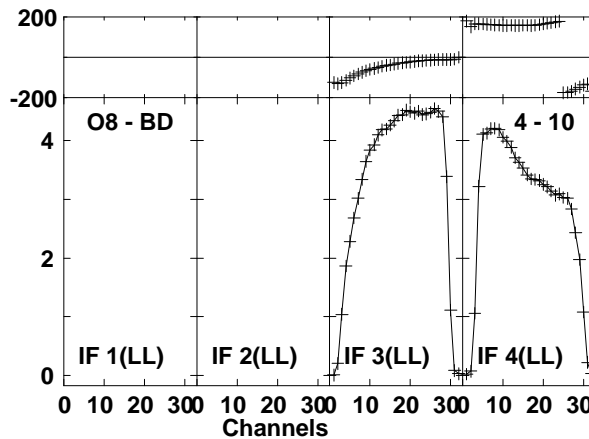
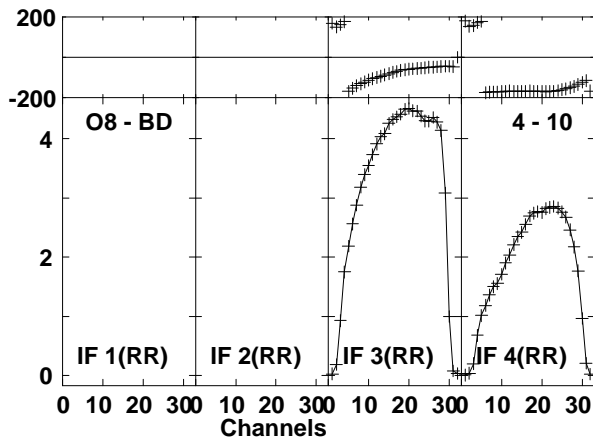
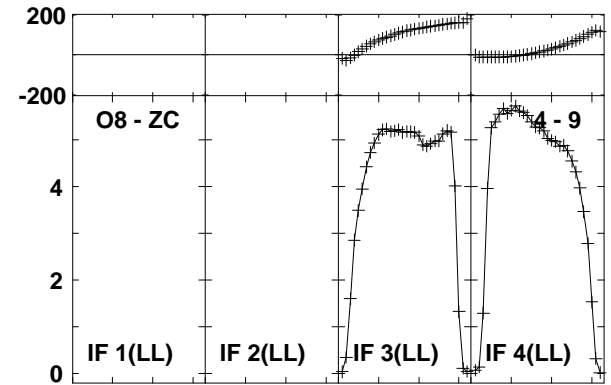
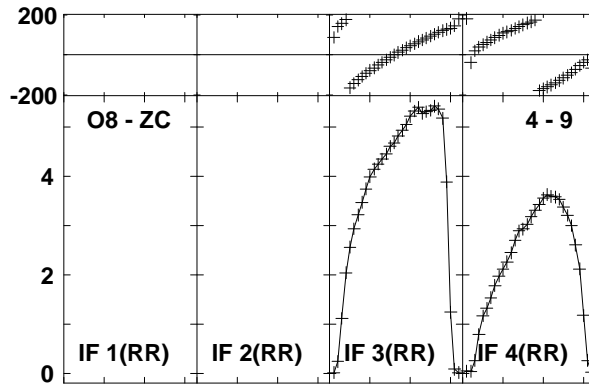
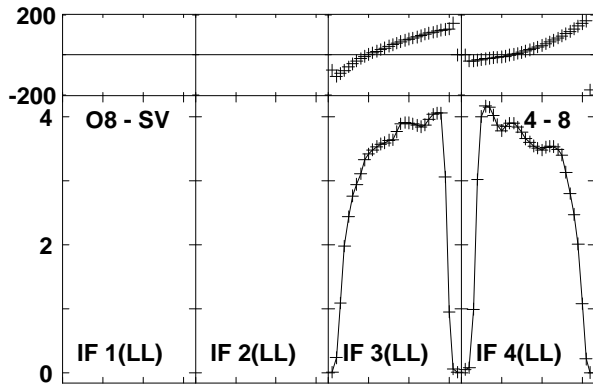
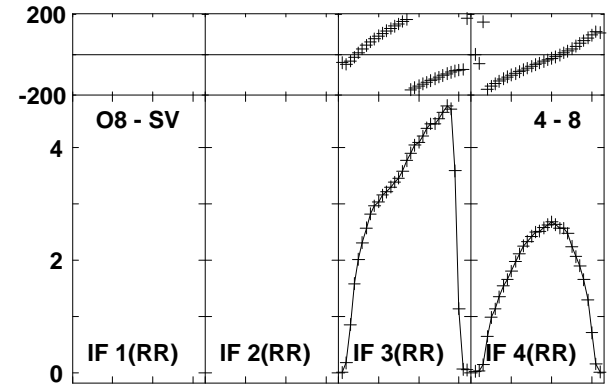
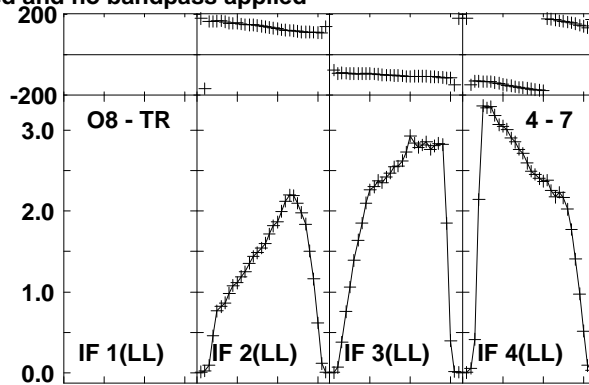
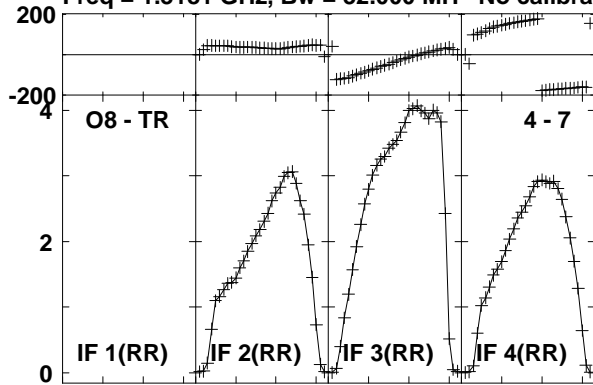

Lower frame: Milli Ampl Jy Top frame: Phas deg
Vector averaged cross-power spectrum Baseline: O8 (04) - TR (07)
Timerange: 00/08:28:33 to 00/08:33:29

Plot file version 99 created 20-NOV-2015 13:43:56
 3C84 EO013 1.UVDATA.1
 Freq = 1.3181 GHz, Bw = 32.000 MH No calibration applied and no bandpass applied

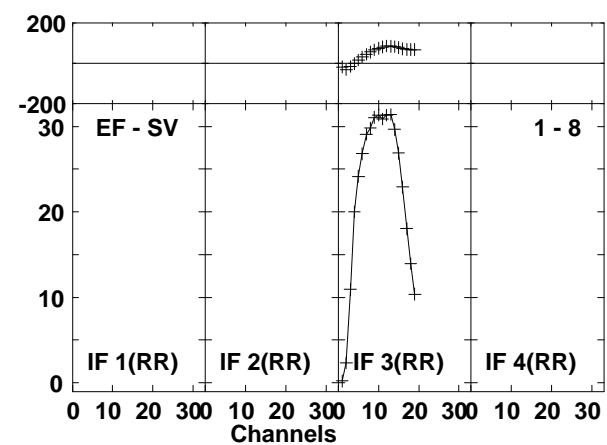
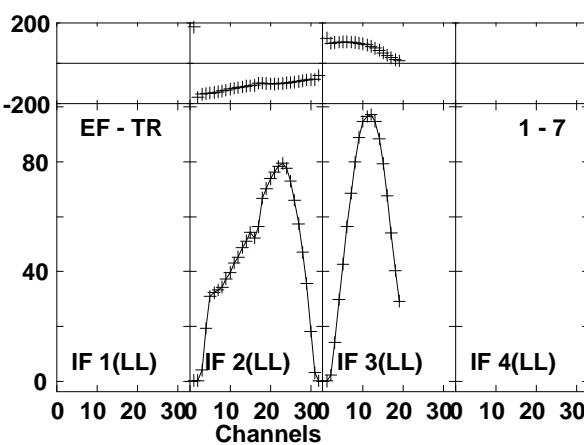
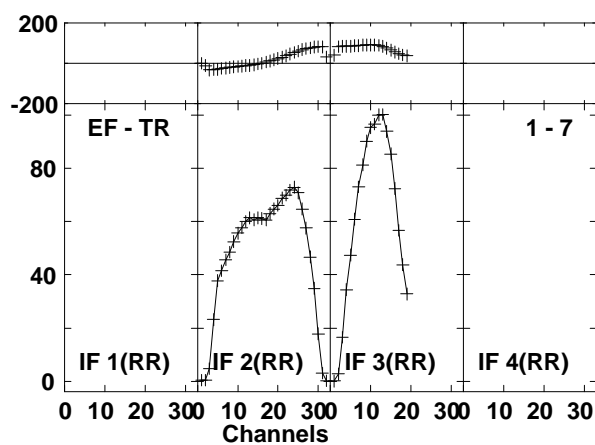
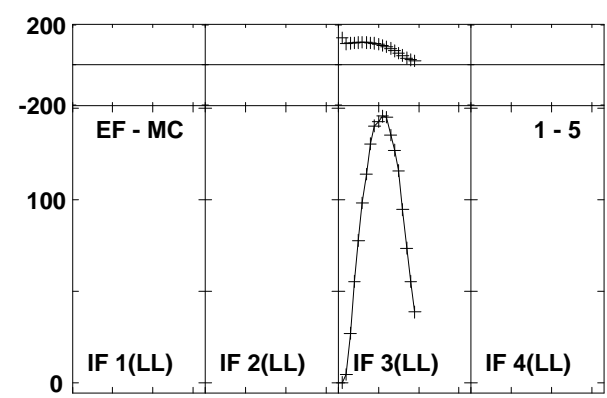
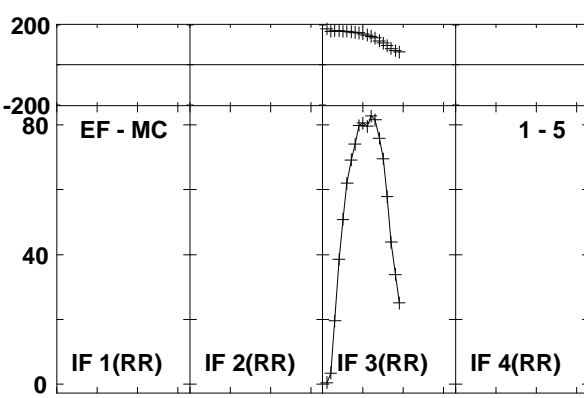
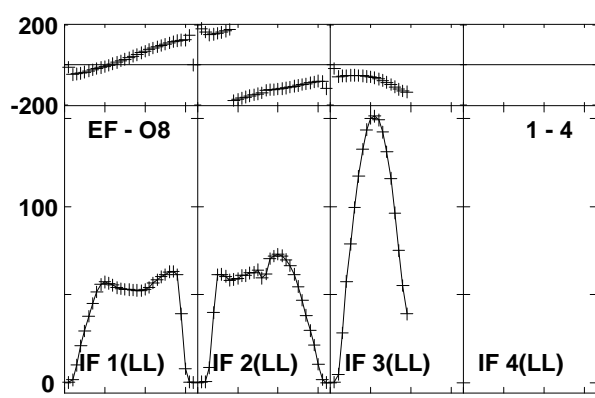
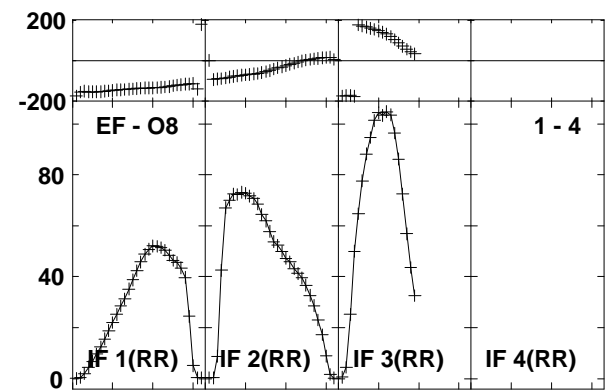
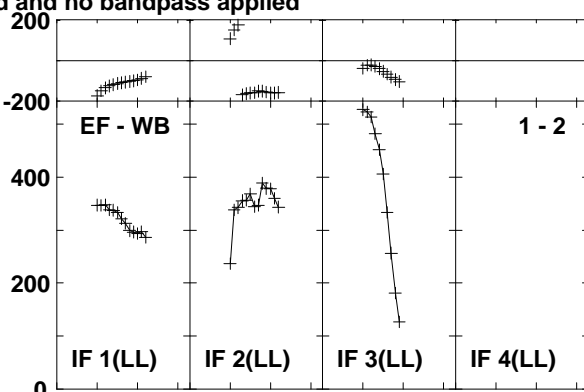
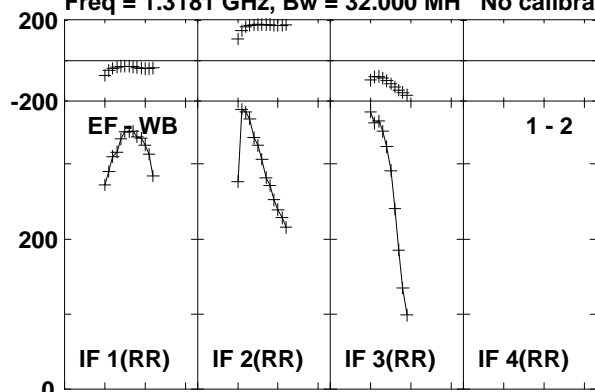

Lower frame: Milli Ampl Jy Top frame: Phas deg
 Vector averaged cross-power spectrum Baseline: EF (01) - WB (02)
 Timerange: 00/08:36:43 to 00/08:46:39

Plot file version 100 created 20-NOV-2015 13:43:56
 3C84 EO13 1.UVDATA.1
 Freq = 1.3181 GHz, Bw = 32.000 MH No calibration applied and no bandpass applied

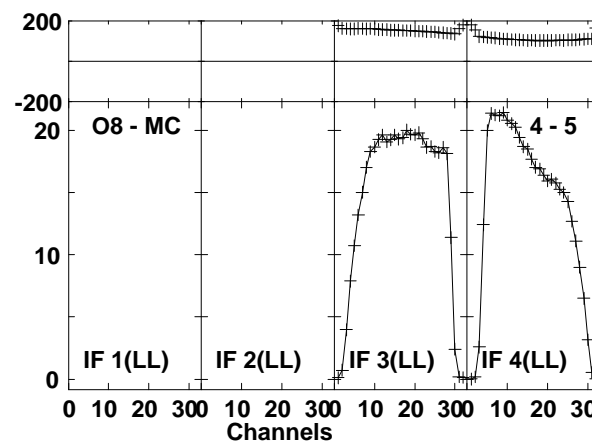
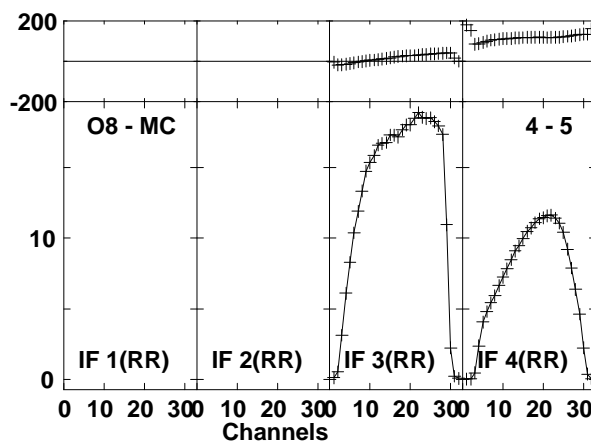
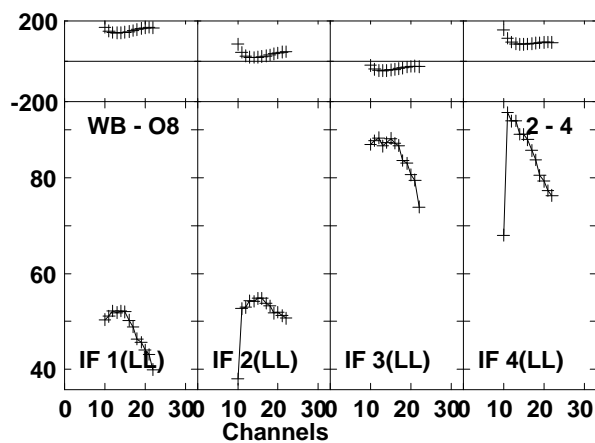
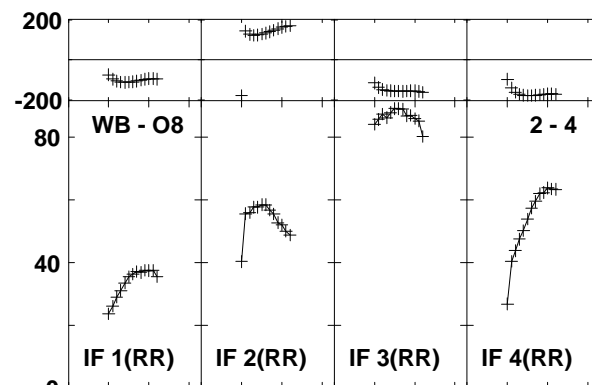
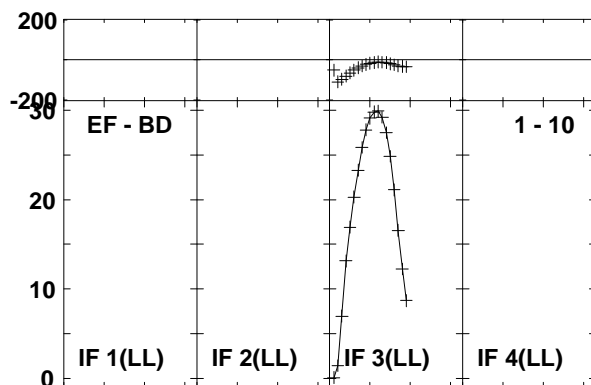
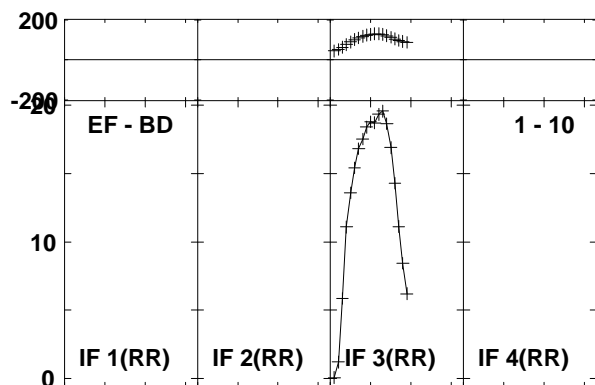
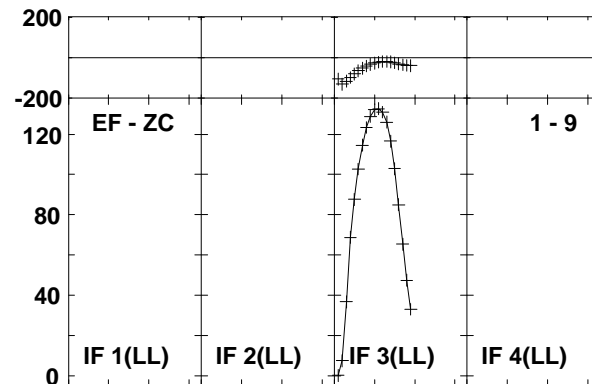
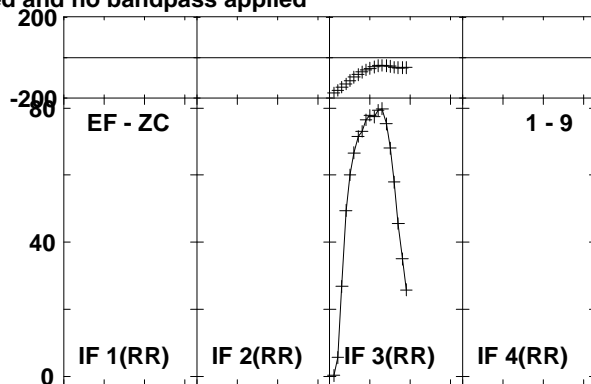
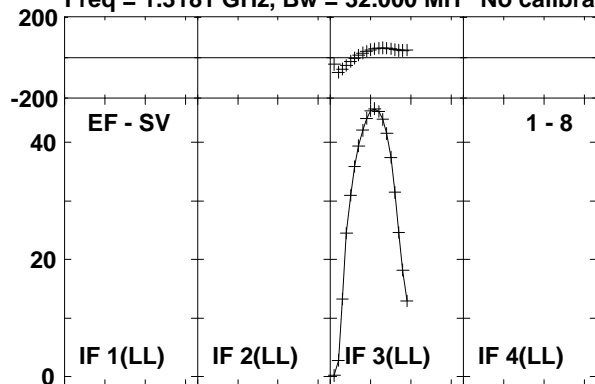

Lower frame: Milli Ampl Jy Top frame: Phas deg
 Vector averaged cross-power spectrum Baseline: EF (01) - SV (08)
 Timerange: 00/08:36:43 to 00/08:46:39

Plot file version 101 created 20-NOV-2015 13:43:56
 3C84 EO013 1.UVDATA.1
 Freq = 1.3181 GHz, Bw = 32.000 MH No calibration applied and no bandpass applied

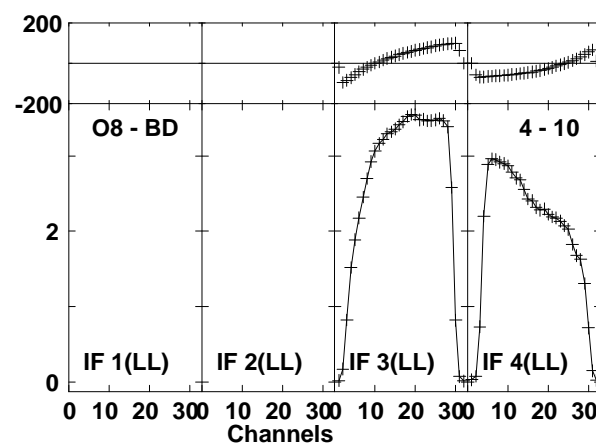
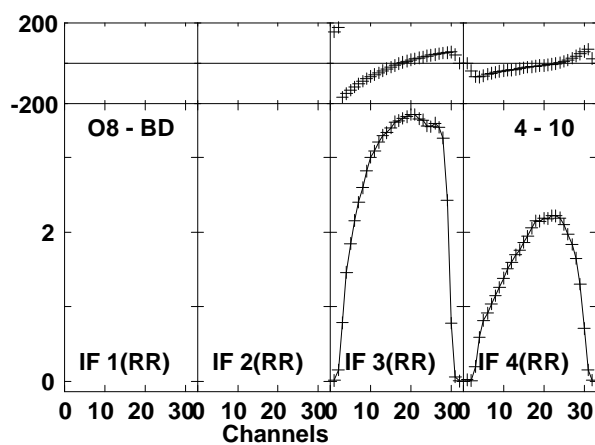
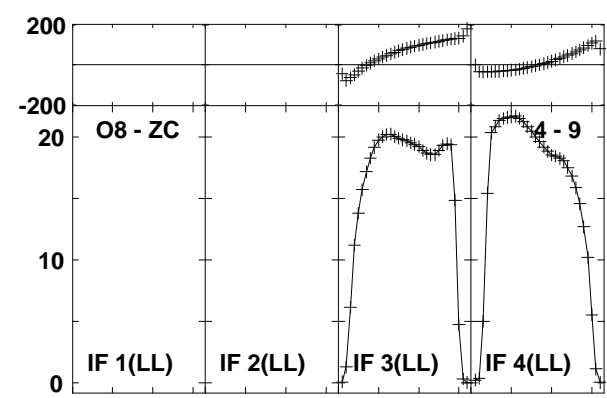
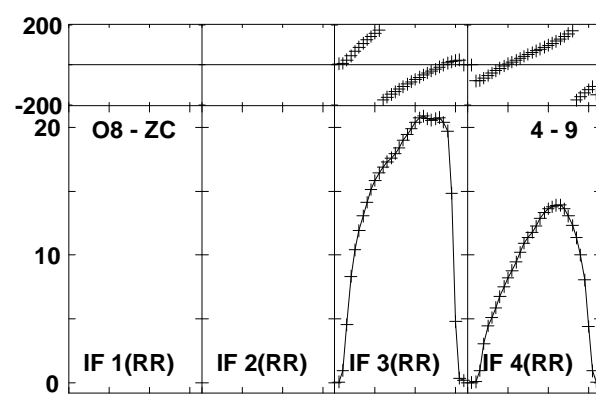
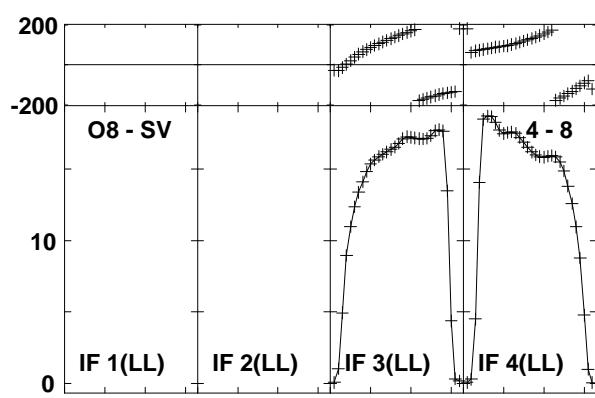
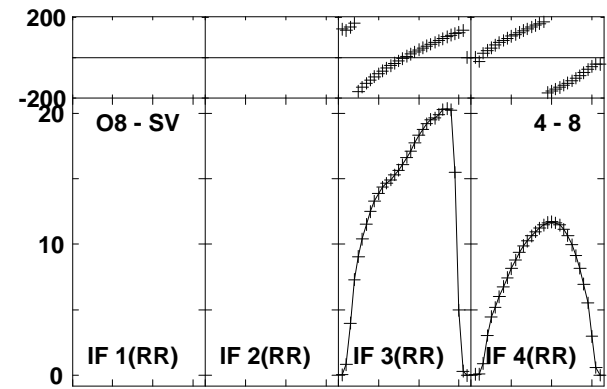
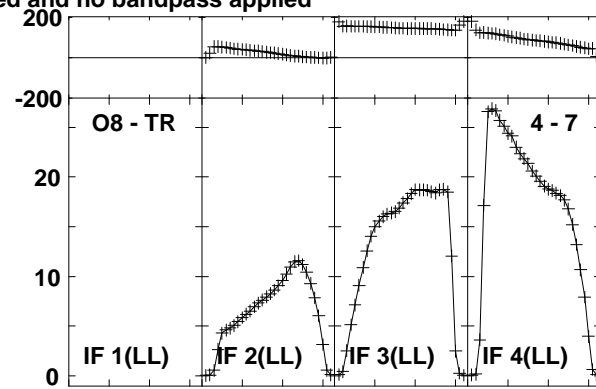
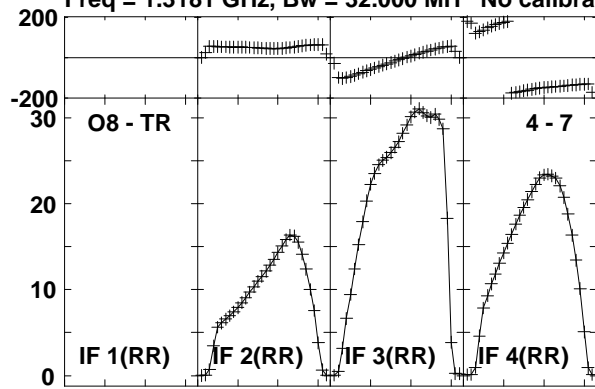

Lower frame: Milli Ampl Jy Top frame: Phas deg
 Vector averaged cross-power spectrum Baseline: O8 (04) - TR (07)
 Timerange: 00/08:36:43 to 00/08:46:39

Plot file version 102 created 20-NOV-2015 13:43:56
 3C84 EO013 1.UVDATA.1
 Freq = 1.3181 GHz, Bw = 32.000 MH No calibration applied and no bandpass applied

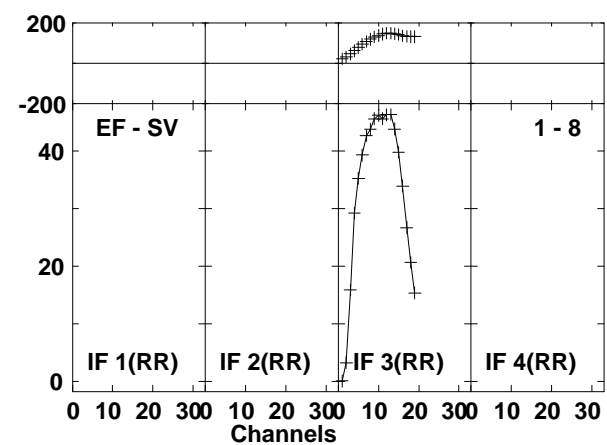
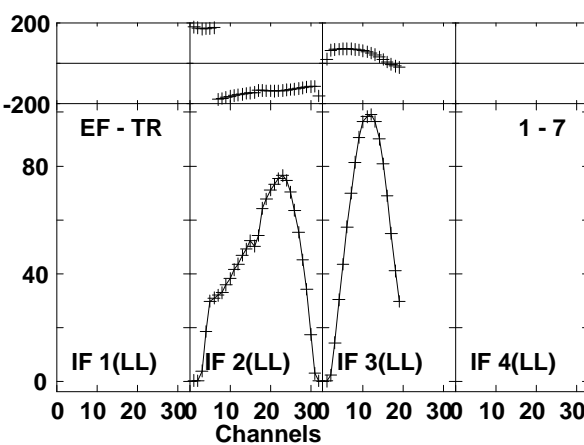
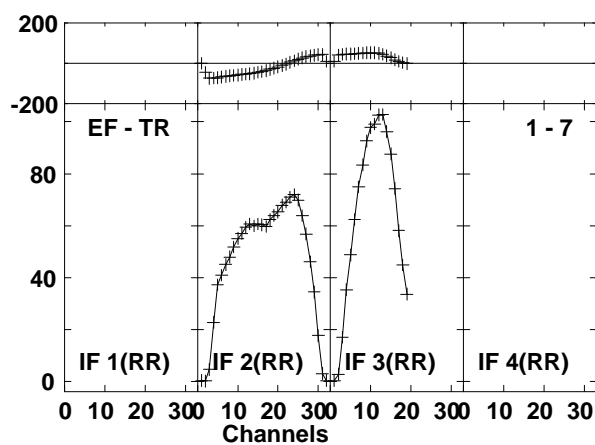
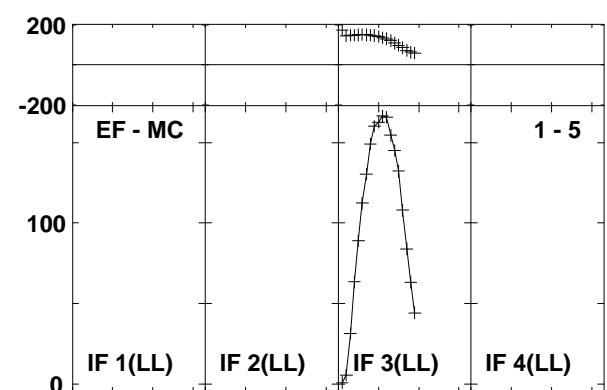
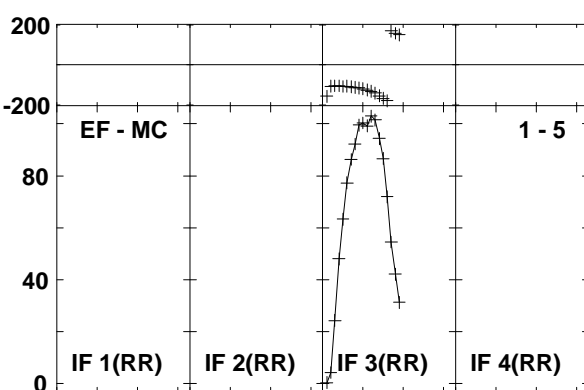
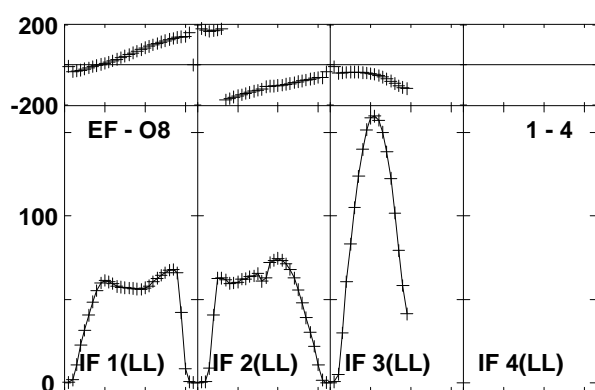
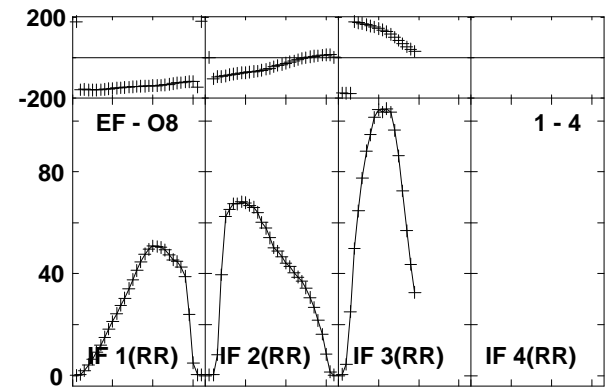
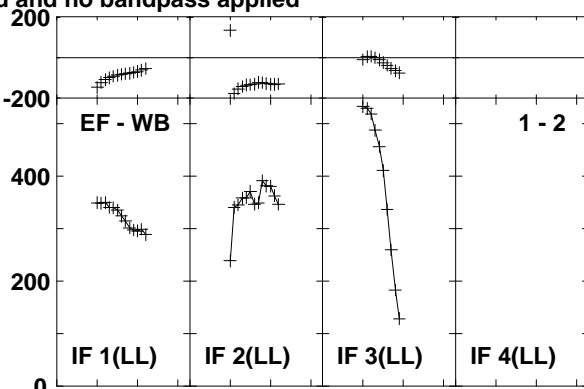
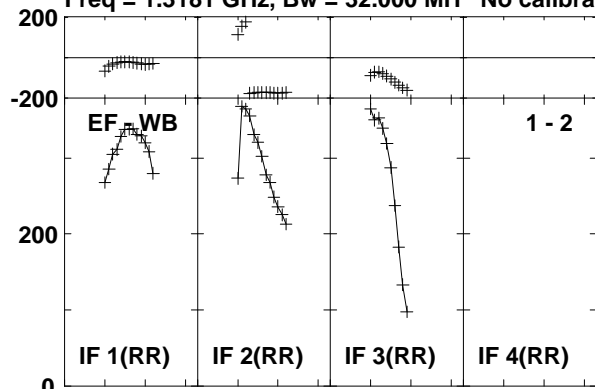

Lower frame: Milli Ampl Jy Top frame: Phas deg
 Vector averaged cross-power spectrum Baseline: EF (01) - WB (02)
 Timerange: 00/08:47:13 to 00/08:57:09

Plot file version 103 created 20-NOV-2015 13:43:56
 3C84 EO13 1.UVDATA.1
 Freq = 1.3181 GHz, Bw = 32.000 MH No calibration applied and no bandpass applied

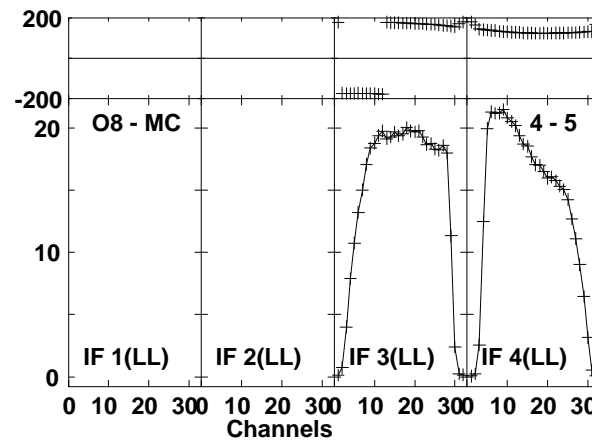
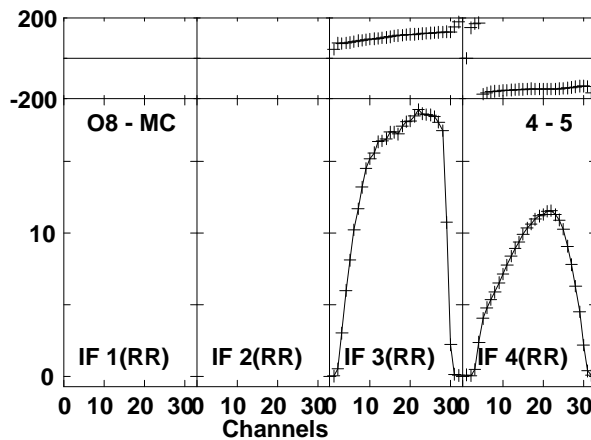
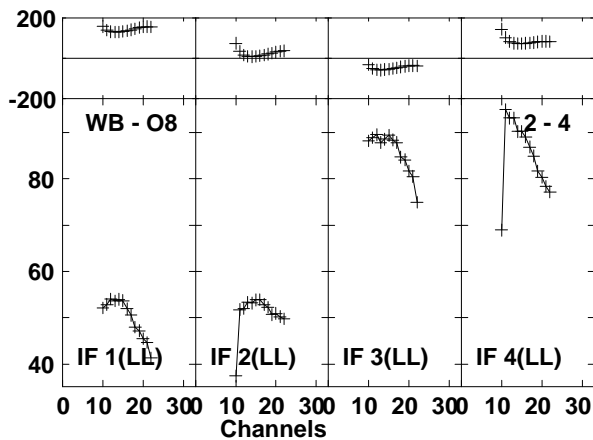
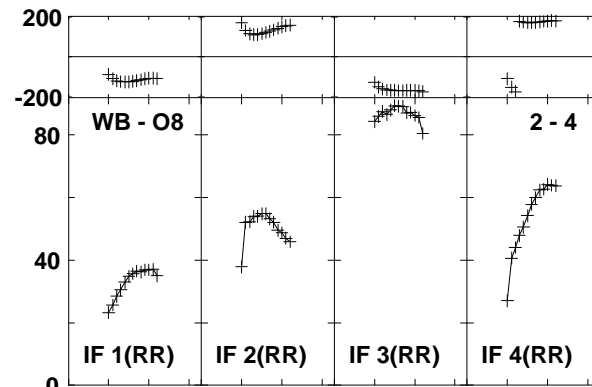
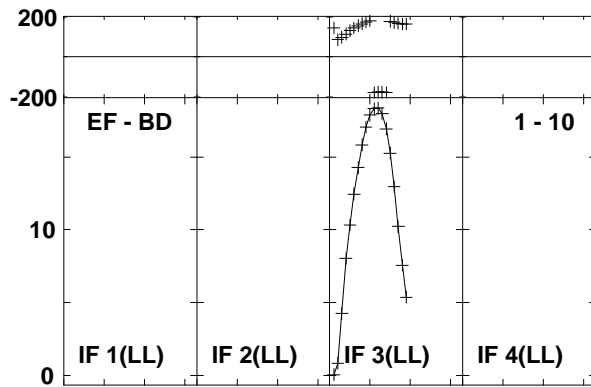
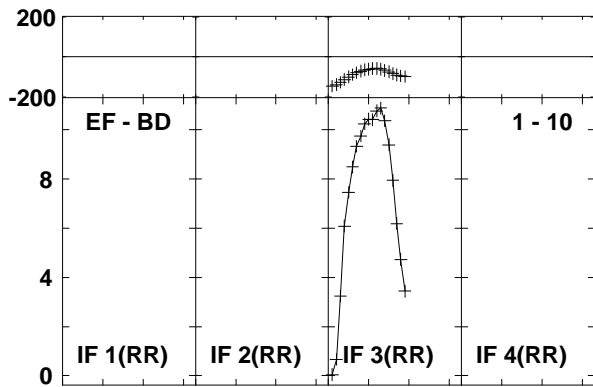
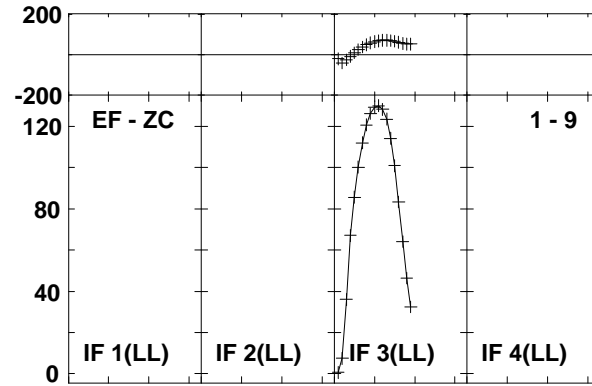
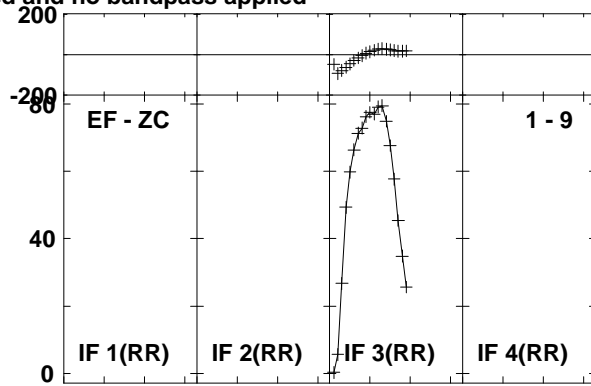
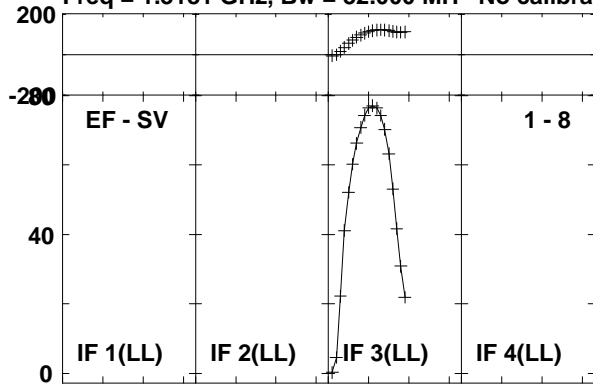

Lower frame: Milli Ampl Jy Top frame: Phas deg
 Vector averaged cross-power spectrum Baseline: EF (01) - SV (08)
 Timerange: 00/08:47:13 to 00/08:57:09

Plot file version 104 created 20-NOV-2015 13:43:56
 3C84 EO013 1.UVDATA.1
 Freq = 1.3181 GHz, Bw = 32.000 MH No calibration applied and no bandpass applied

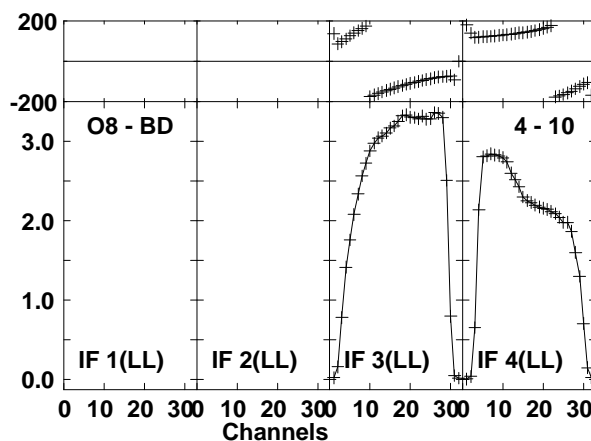
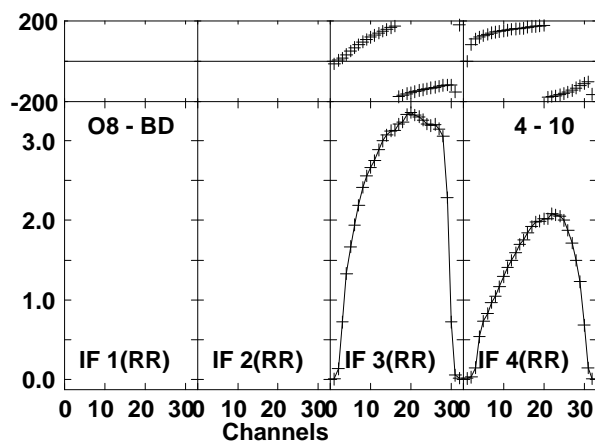
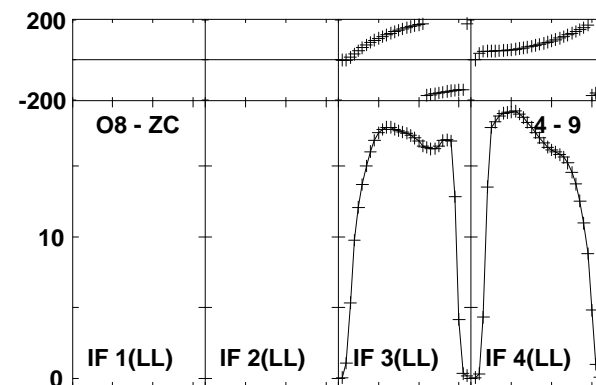
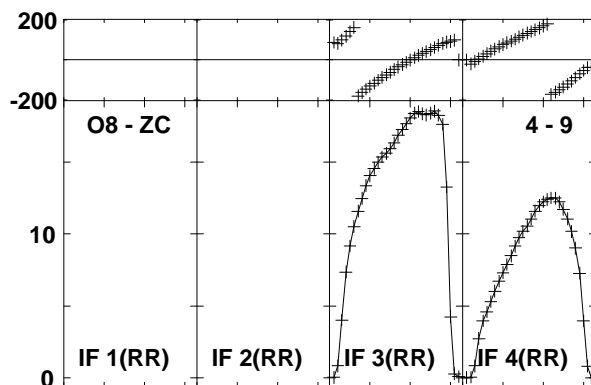
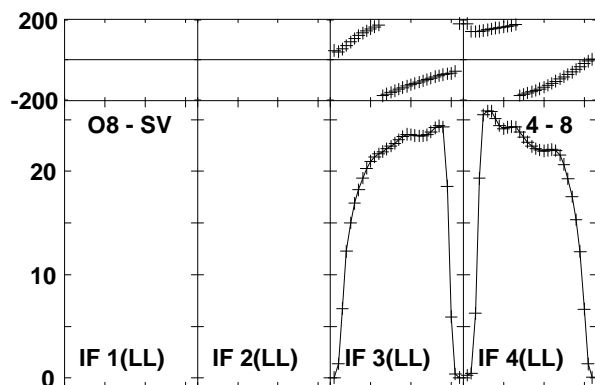
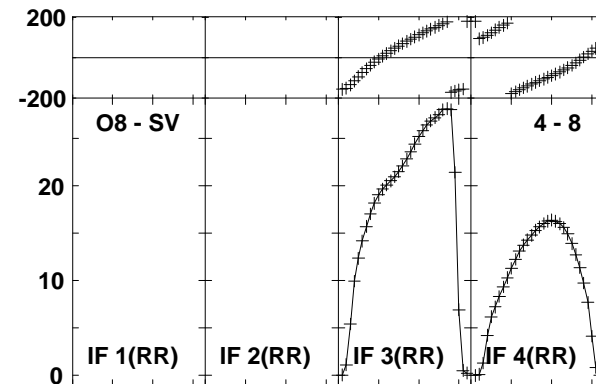
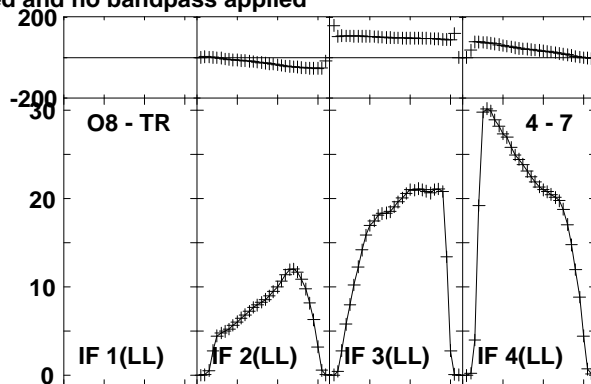
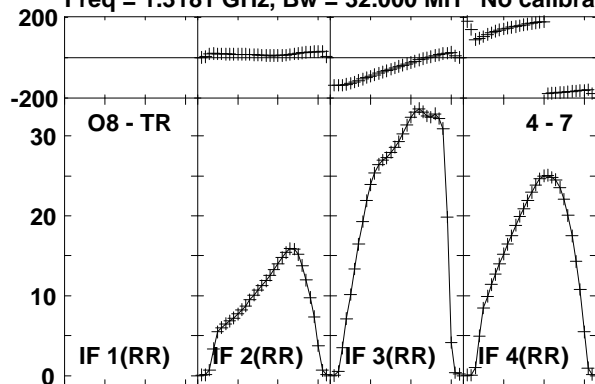

Lower frame: Milli Ampl Jy Top frame: Phas deg
 Vector averaged cross-power spectrum Baseline: O8 (04) - TR (07)
 Timerange: 00/08:47:13 to 00/08:57:09

Plot file version 105 created 20-NOV-2015 13:43:57
 3C84 EO013 1.UVDATA.1
 Freq = 1.3181 GHz, Bw = 32.000 MH No calibration applied and no bandpass applied

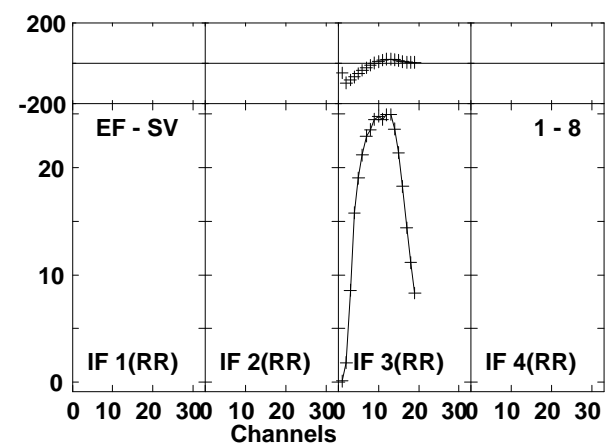
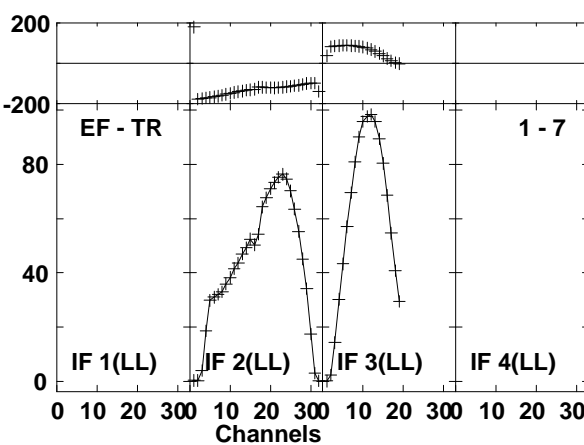
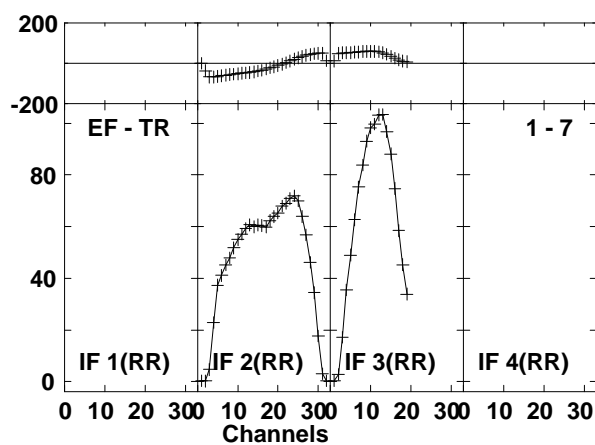
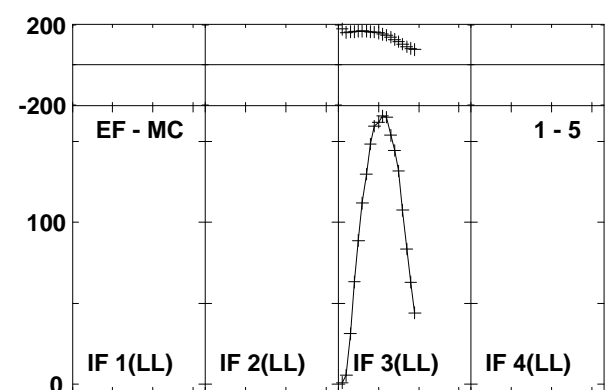
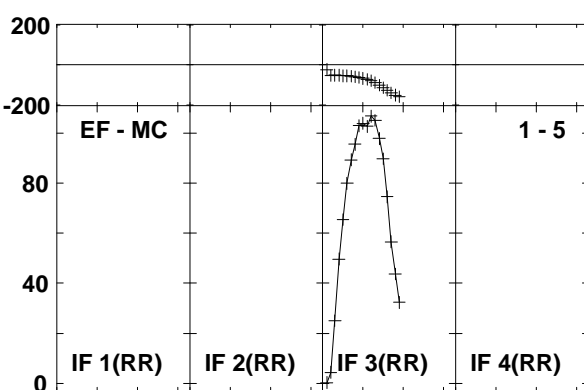
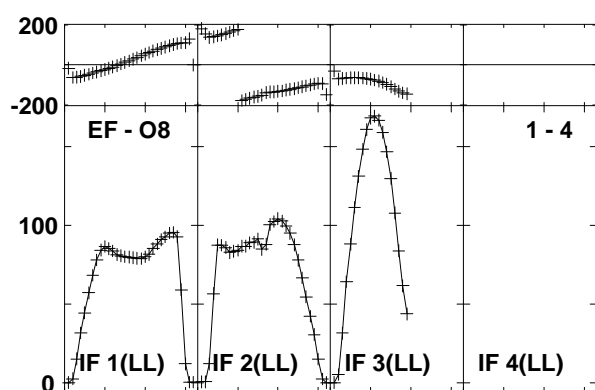
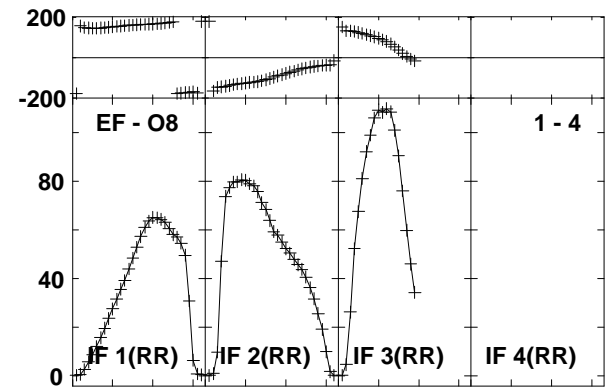
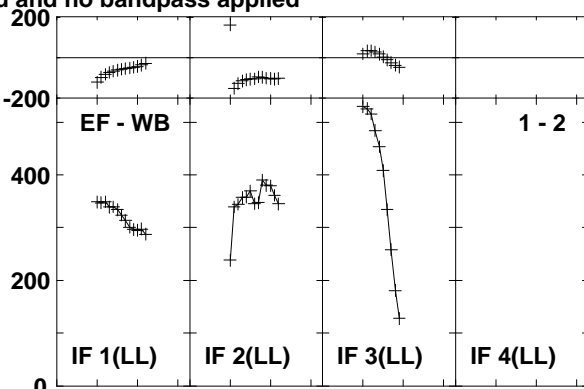
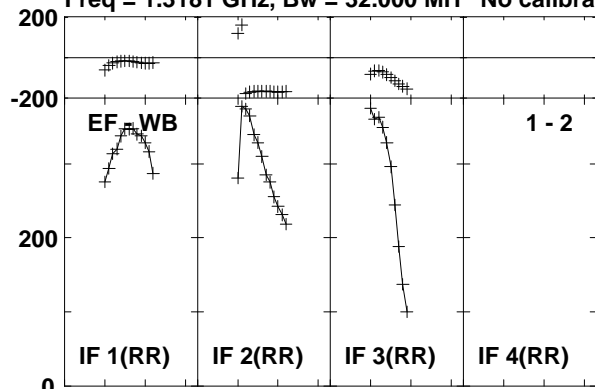

Lower frame: Milli Ampl Jy Top frame: Phas deg
 Vector averaged cross-power spectrum Baseline: EF (01) - WB (02)
 Timerange: 00/08:57:43 to 00/09:07:39

Plot file version 106 created 20-NOV-2015 13:43:57
 3C84 EO013 1.UVDATA.1
 Freq = 1.3181 GHz, Bw = 32.000 MH No calibration applied and no bandpass applied

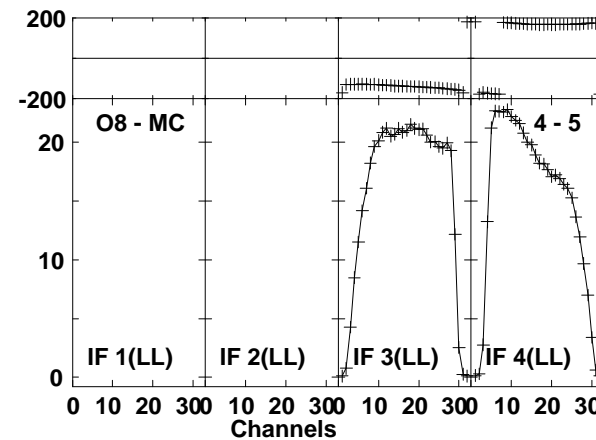
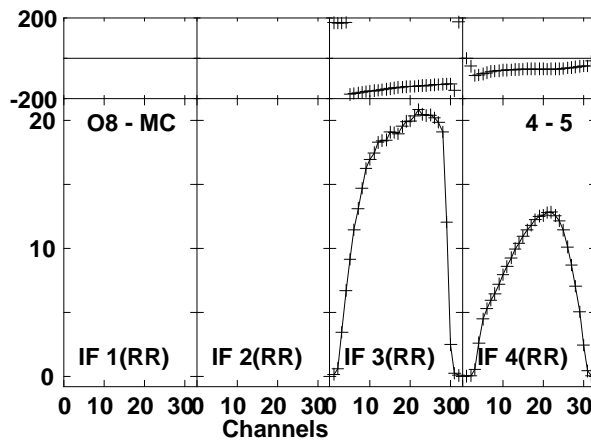
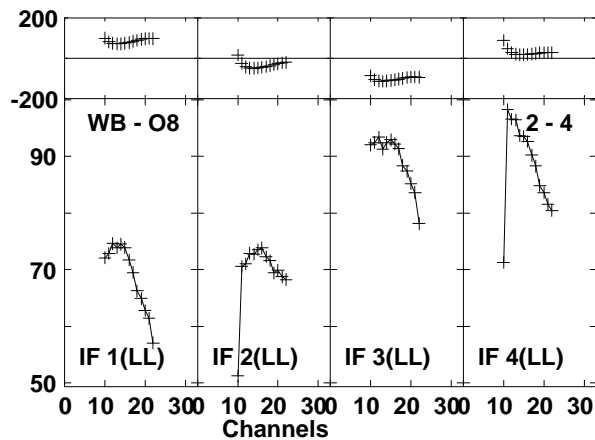
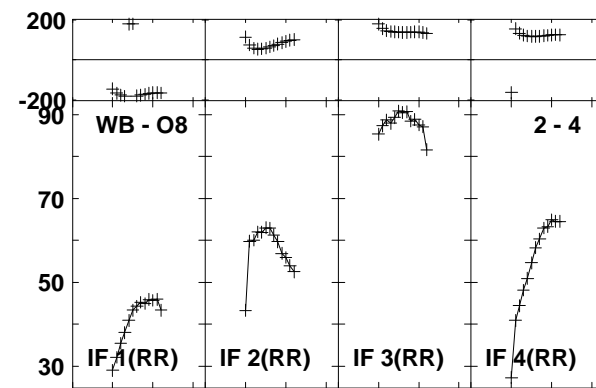
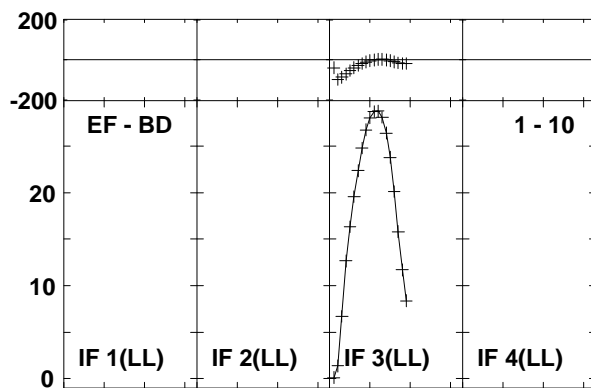
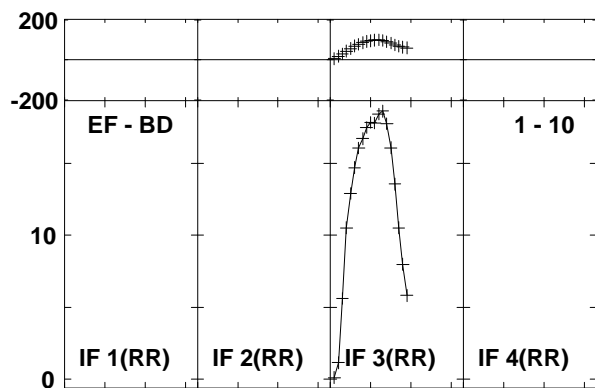
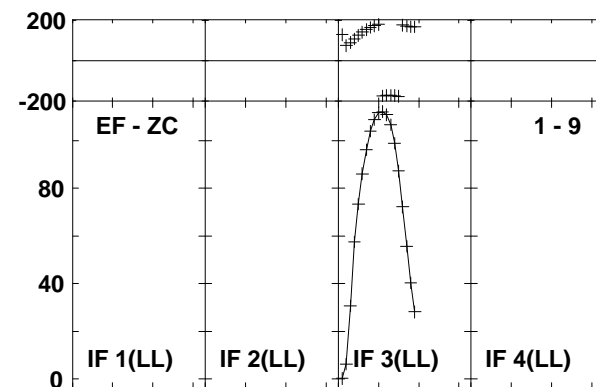
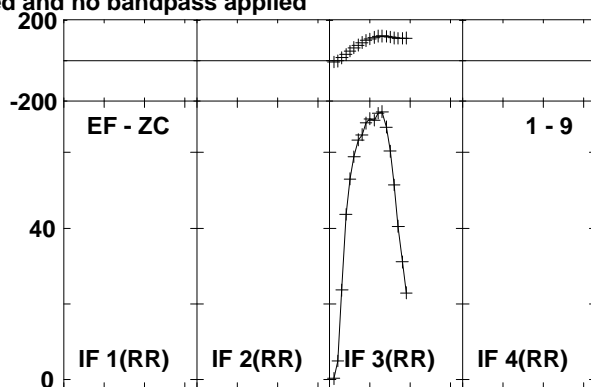
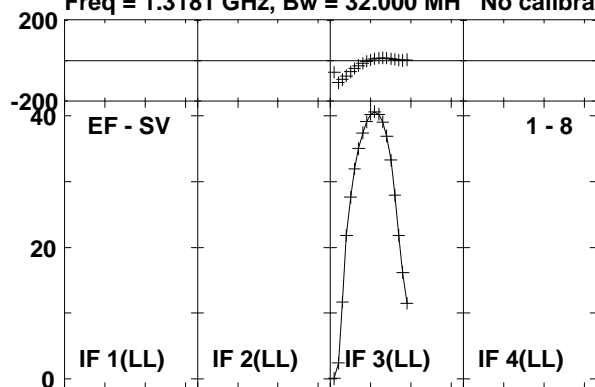

Lower frame: Milli Ampl Jy Top frame: Phas deg
 Vector averaged cross-power spectrum Baseline: EF (01) - SV (08)
 Timerange: 00/08:57:43 to 00/09:07:39

Plot file version 107 created 20-NOV-2015 13:43:57
 3C84 EO013 1.UVDATA.1
 Freq = 1.3181 GHz, Bw = 32.000 MH No calibration applied and no bandpass applied

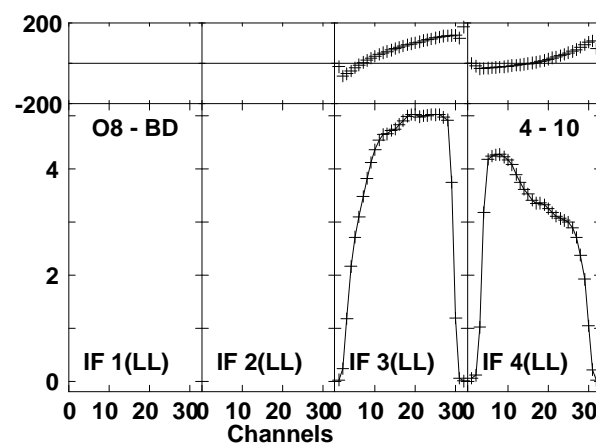
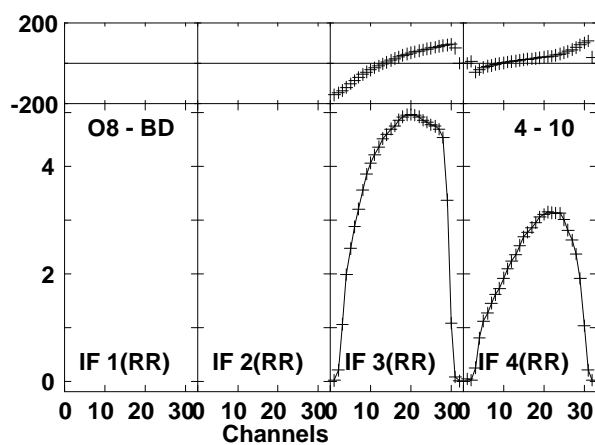
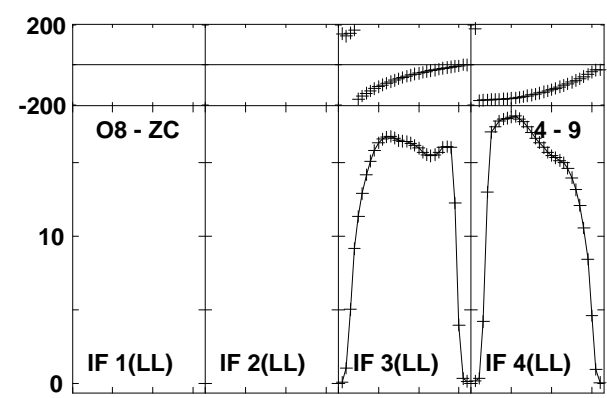
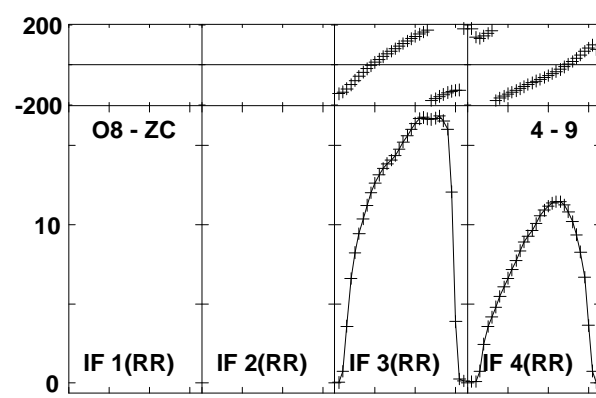
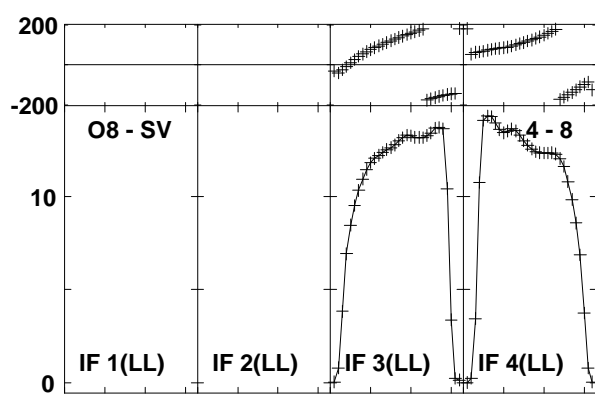
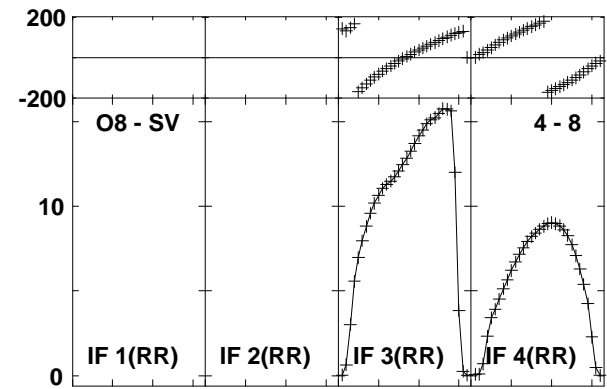
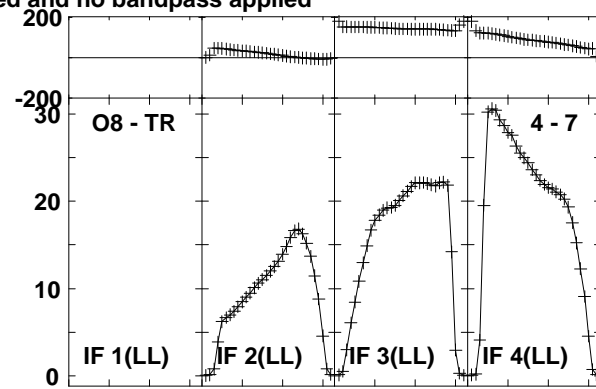
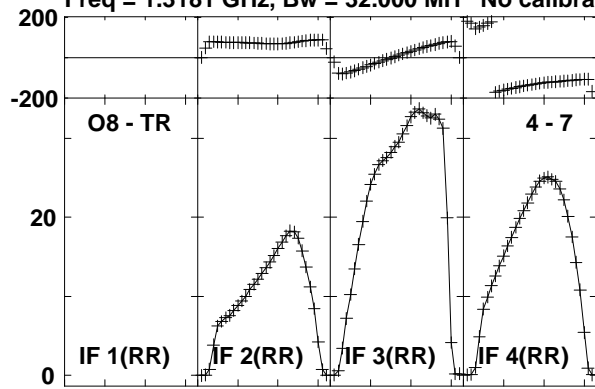

Lower frame: Milli Ampl Jy Top frame: Phas deg
 Vector averaged cross-power spectrum Baseline: O8 (04) - TR (07)
 Timerange: 00/08:57:43 to 00/09:07:39

Plot file version 108 created 20-NOV-2015 13:43:57

3C84 EO013 1.UVDATA.1

Freq = 1.3181 GHz, Bw = 32.000 MH No calibration applied and no bandpass applied

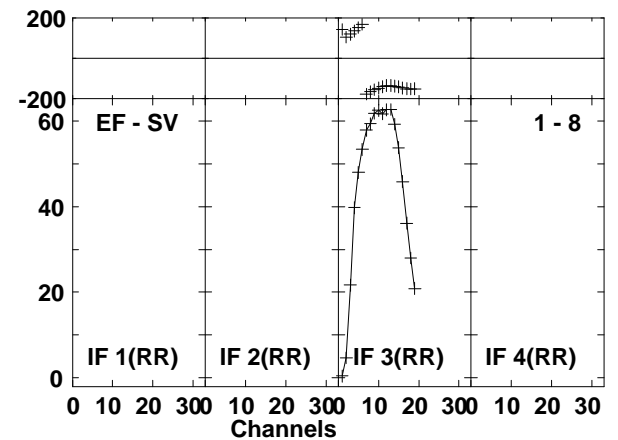
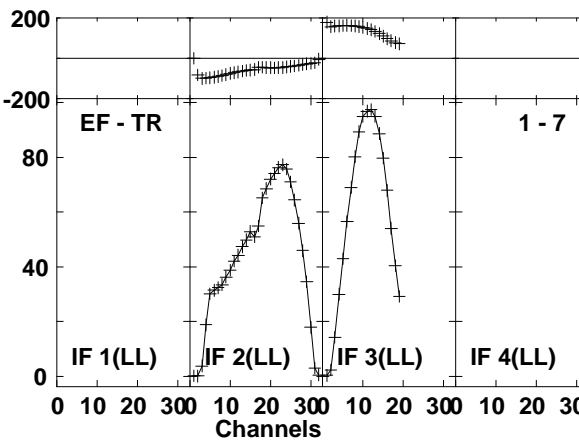
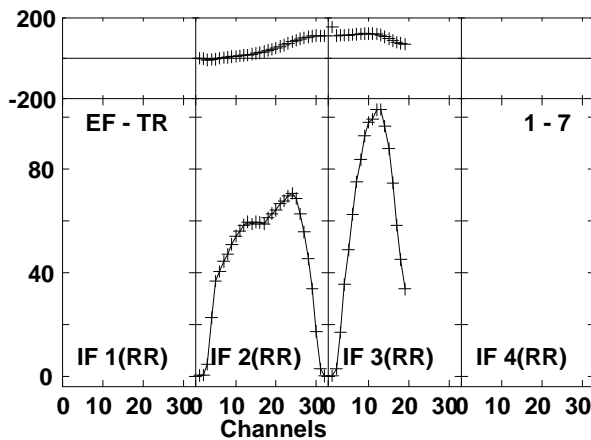
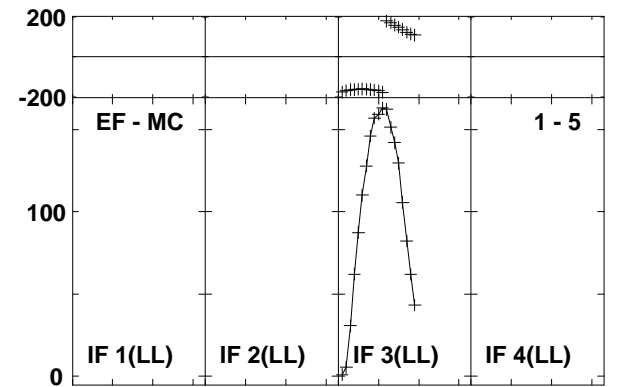
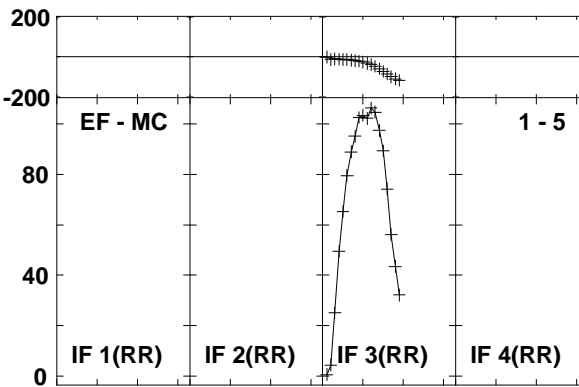
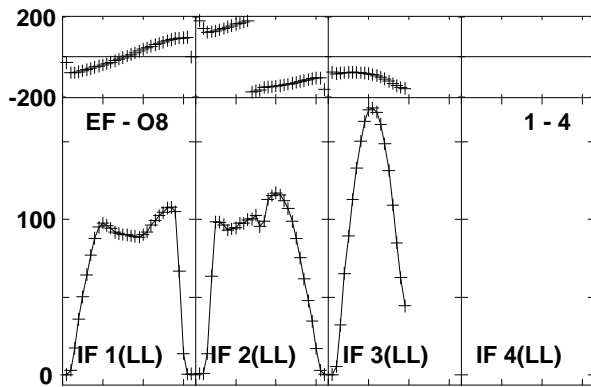
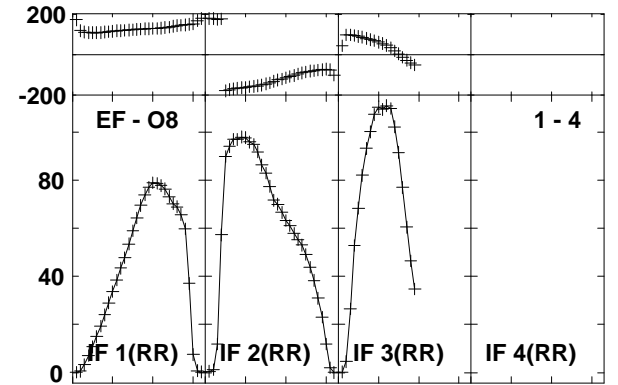
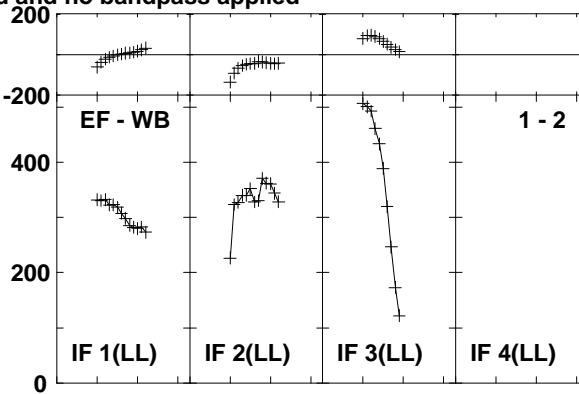
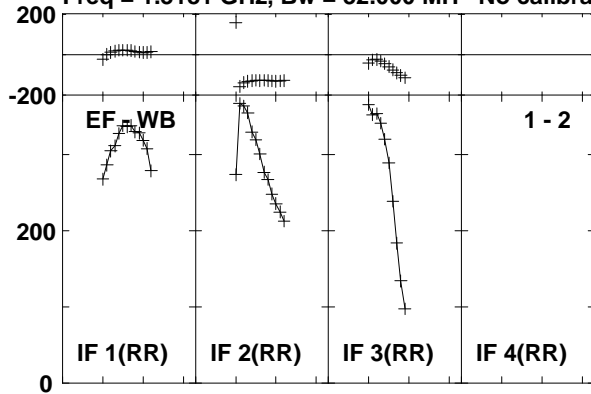

Lower frame: Milli Ampl Jy Top frame: Phas deg
Vector averaged cross-power spectrum Baseline: EF (01) - WB (02)
Timerange: 00/09:08:13 to 00/09:18:09

Plot file version 109 created 20-NOV-2015 13:43:57
 3C84 EO013 1.UVDATA.1
 Freq = 1.3181 GHz, Bw = 32.000 MH No calibration applied and no bandpass applied

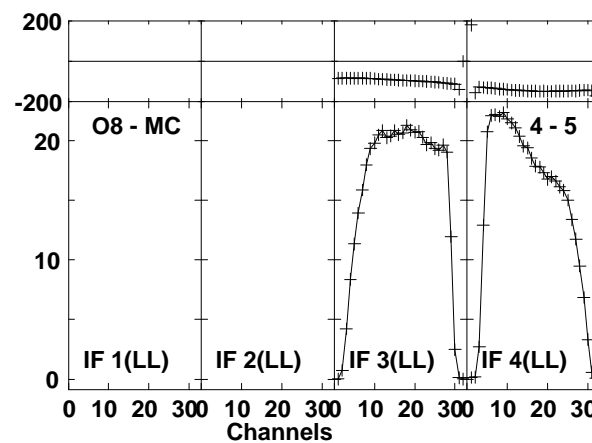
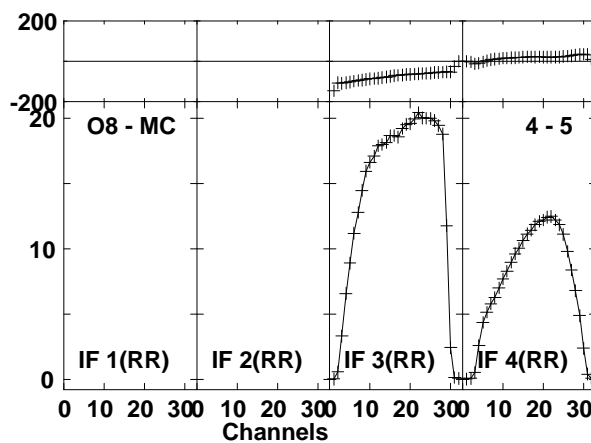
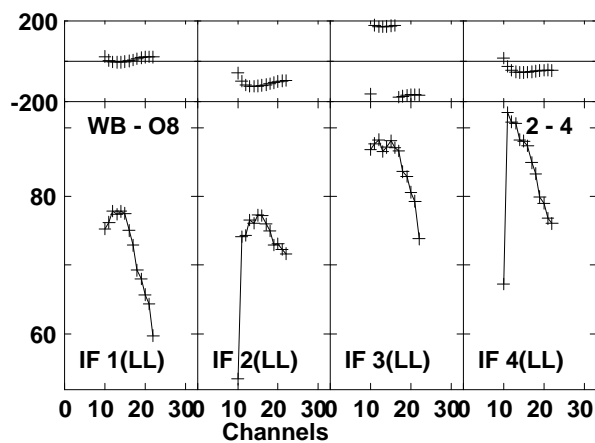
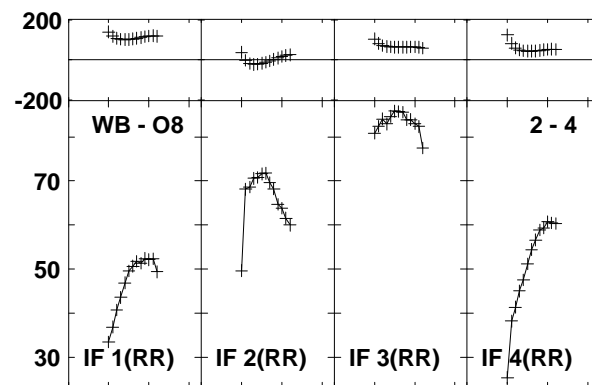
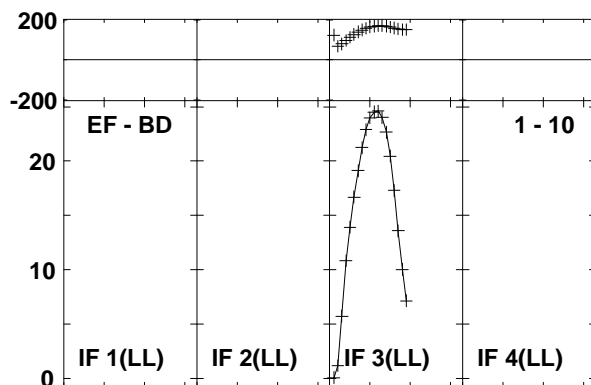
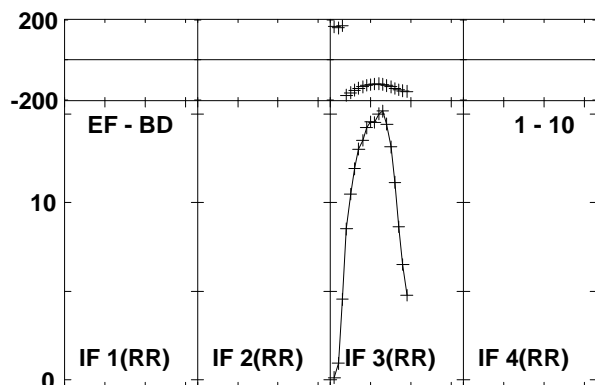
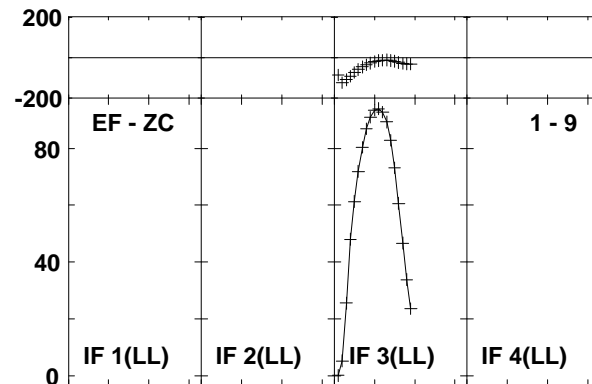
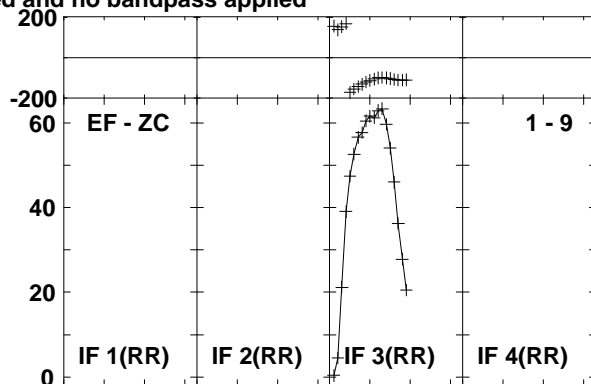
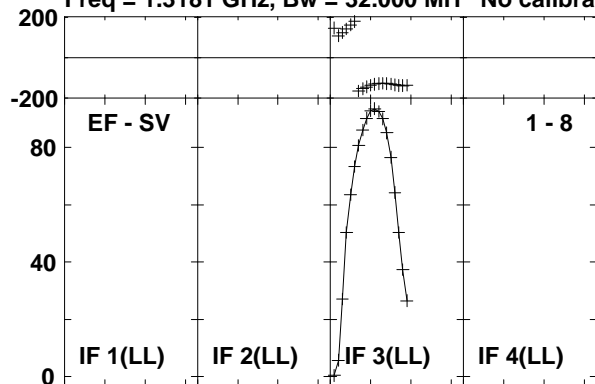

Lower frame: Milli Ampl Jy Top frame: Phas deg
 Vector averaged cross-power spectrum Baseline: EF (01) - SV (08)
 Timerange: 00/09:08:13 to 00/09:18:09

Plot file version 110 created 20-NOV-2015 13:43:57

3C84 EO013 1.UVDATA.1

Freq = 1.3181 GHz, Bw = 32.000 MH No calibration applied and no bandpass applied

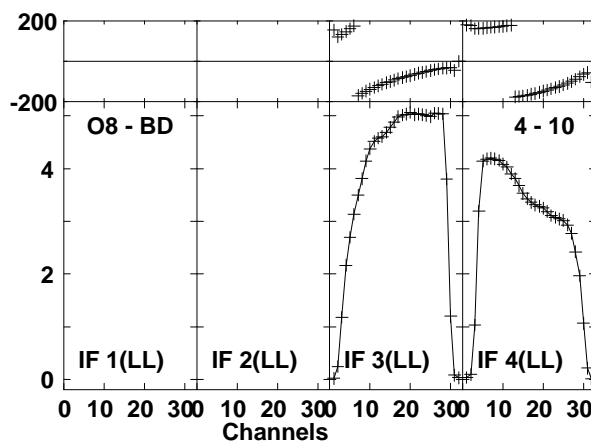
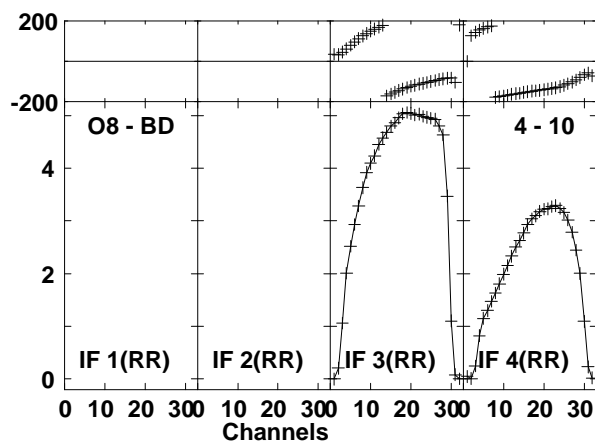
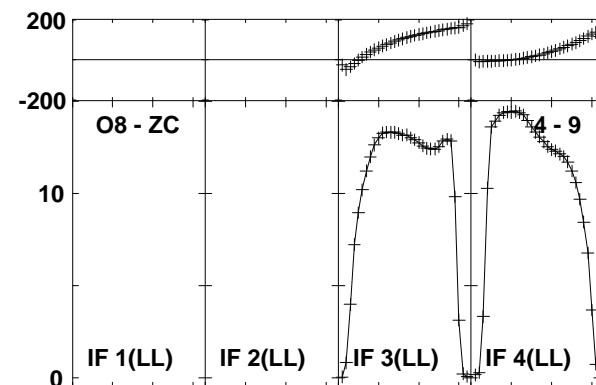
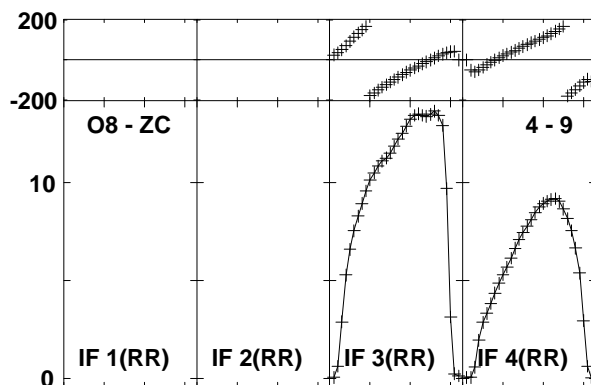
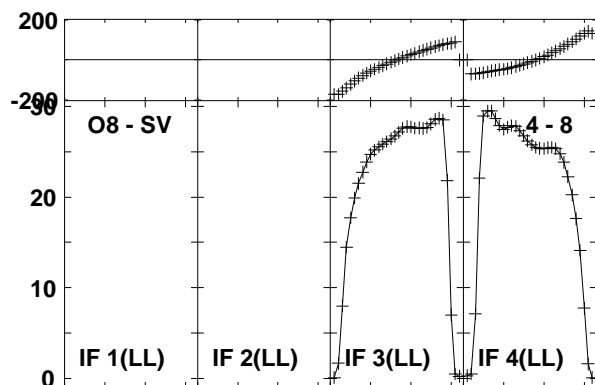
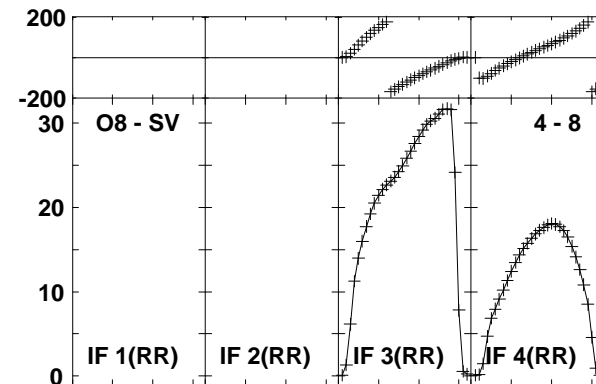
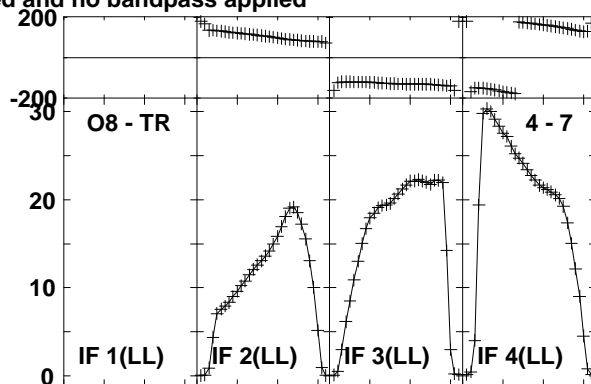
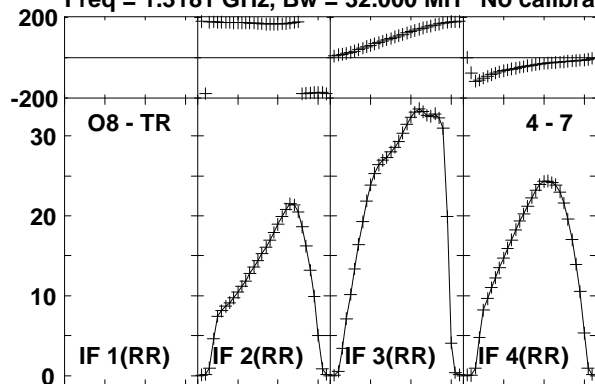

Lower frame: Milli Ampl Jy Top frame: Phas deg

Vector averaged cross-power spectrum Baseline: O8 (04) - TR (07)

Timerange: 00/09:08:13 to 00/09:18:09

Plot file version 111 created 20-NOV-2015 13:43:57

3C84 EO013 1.UVDATA.1

Freq = 1.3181 GHz, Bw = 32.000 MH No calibration applied and no bandpass applied

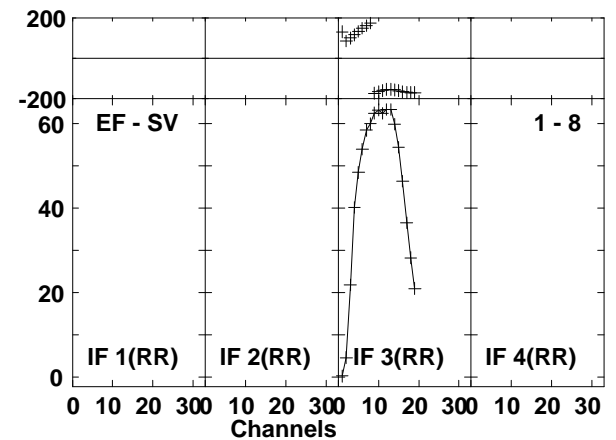
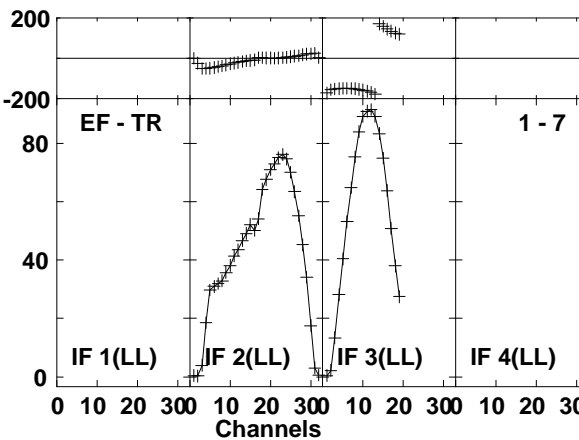
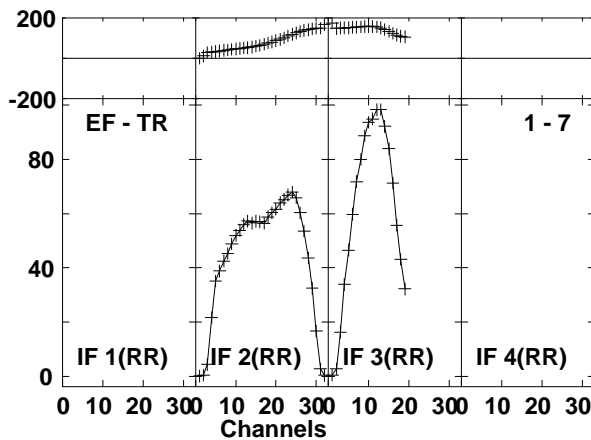
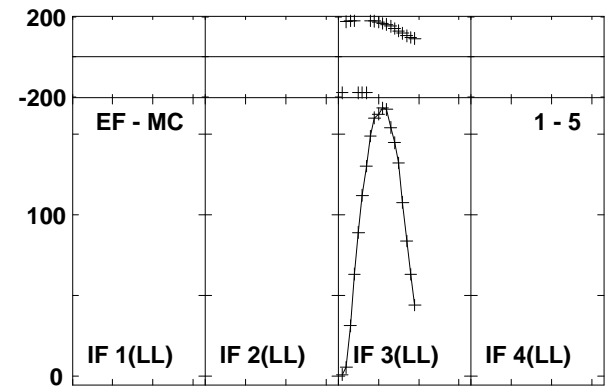
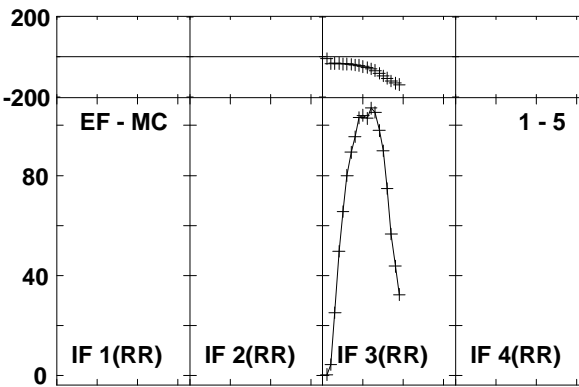
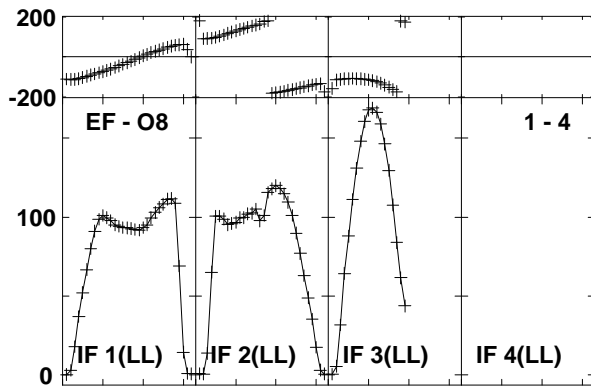
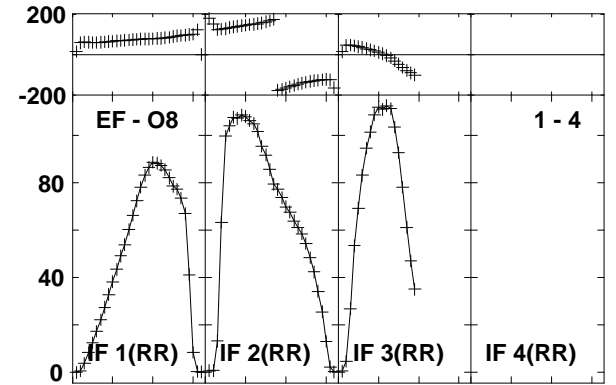
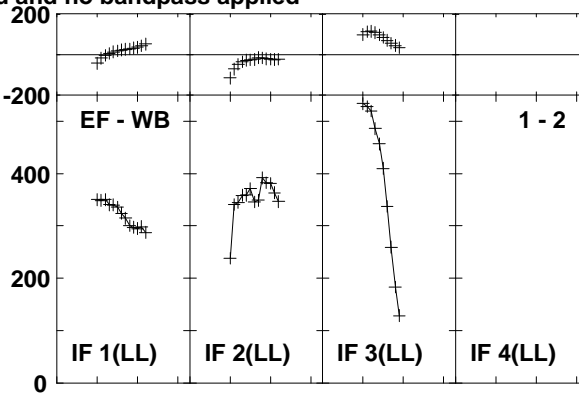
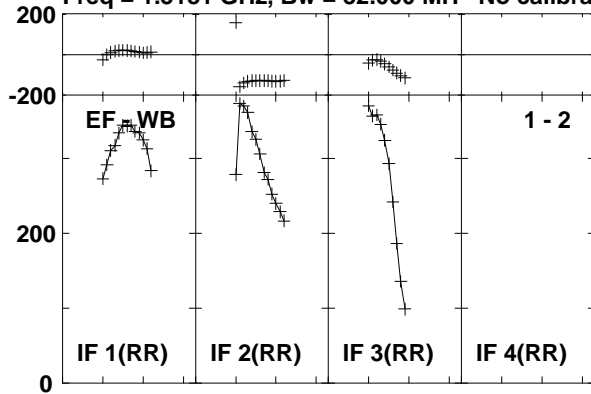

Lower frame: Milli Ampl Jy Top frame: Phas deg
Vector averaged cross-power spectrum Baseline: EF (01) - WB (02)
Timerange: 00/09:18:43 to 00/09:28:39

Plot file version 112 created 20-NOV-2015 13:43:57
 3C84 EO013 1.UVDATA.1
 Freq = 1.3181 GHz, Bw = 32.000 MH No calibration applied and no bandpass applied

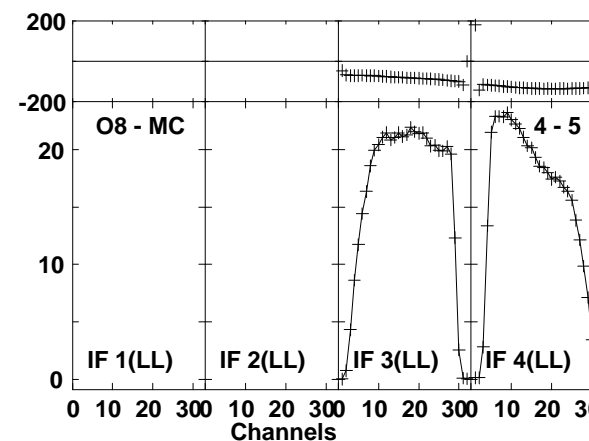
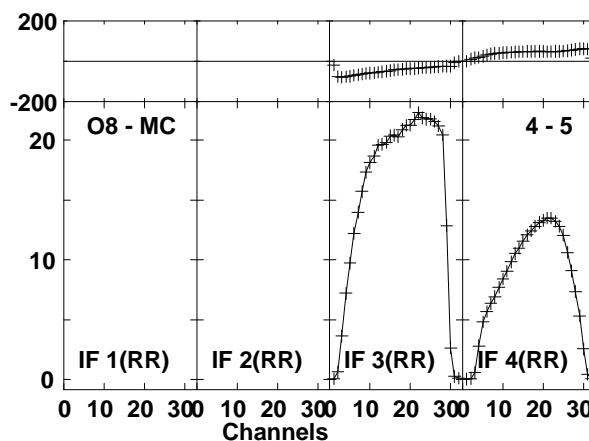
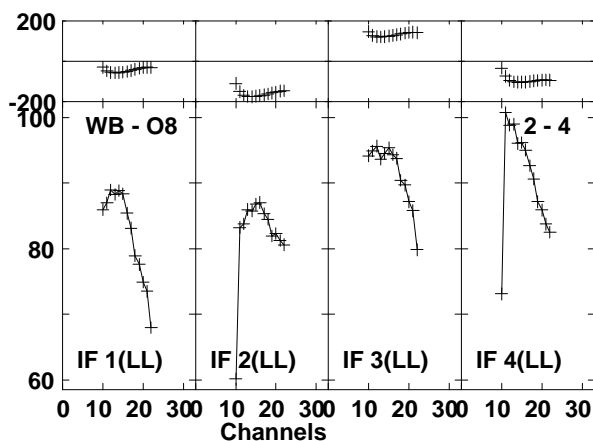
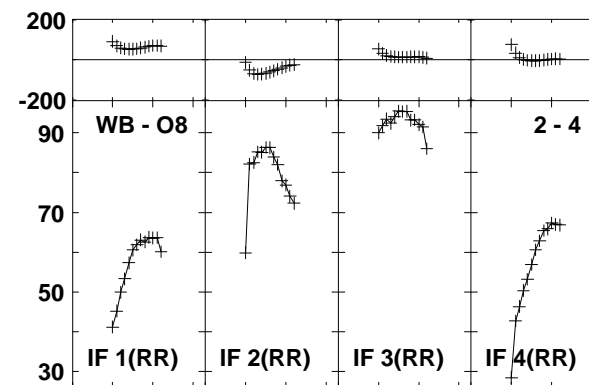
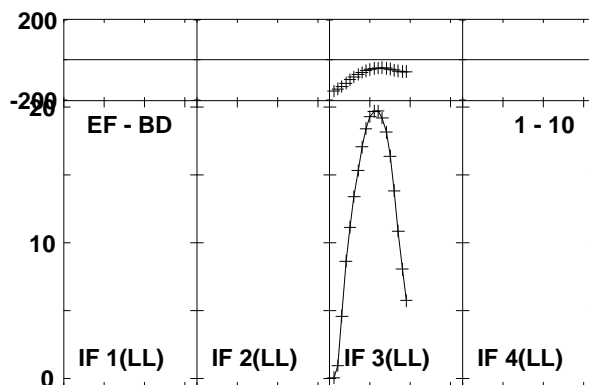
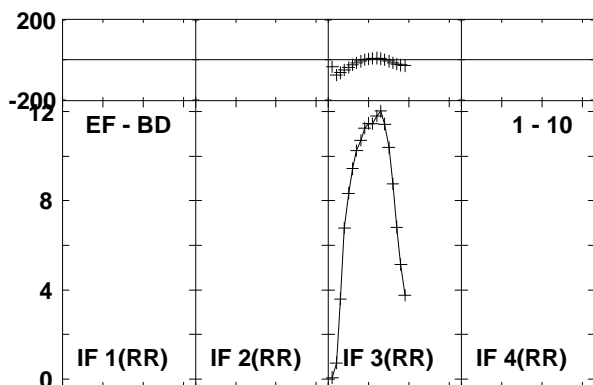
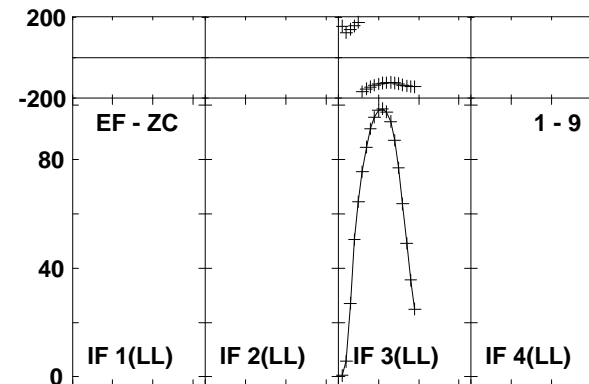
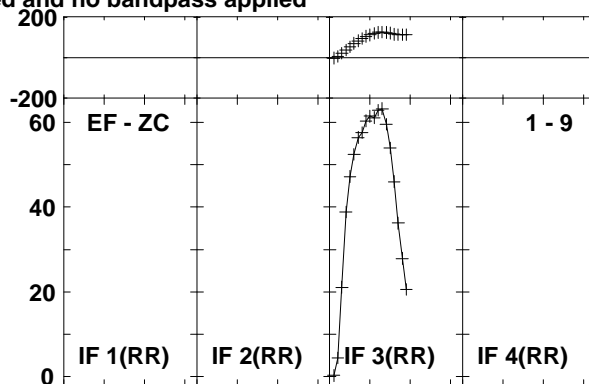
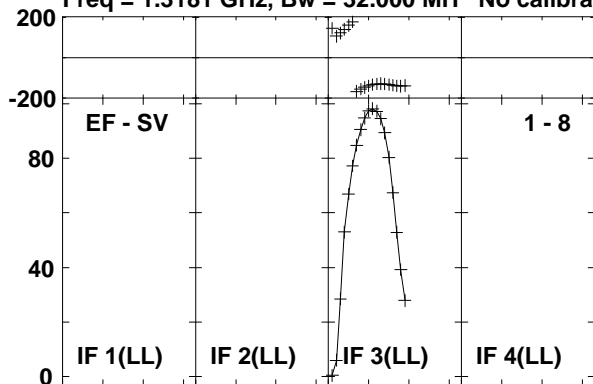

Lower frame: Milli Ampl Jy Top frame: Phas deg
 Vector averaged cross-power spectrum Baseline: EF (01) - SV (08)
 Timerange: 00/09:18:43 to 00/09:28:39

Plot file version 113 created 20-NOV-2015 13:43:57
 3C84 EO013 1.UVDATA.1
 Freq = 1.3181 GHz, Bw = 32.000 MH No calibration applied and no bandpass applied

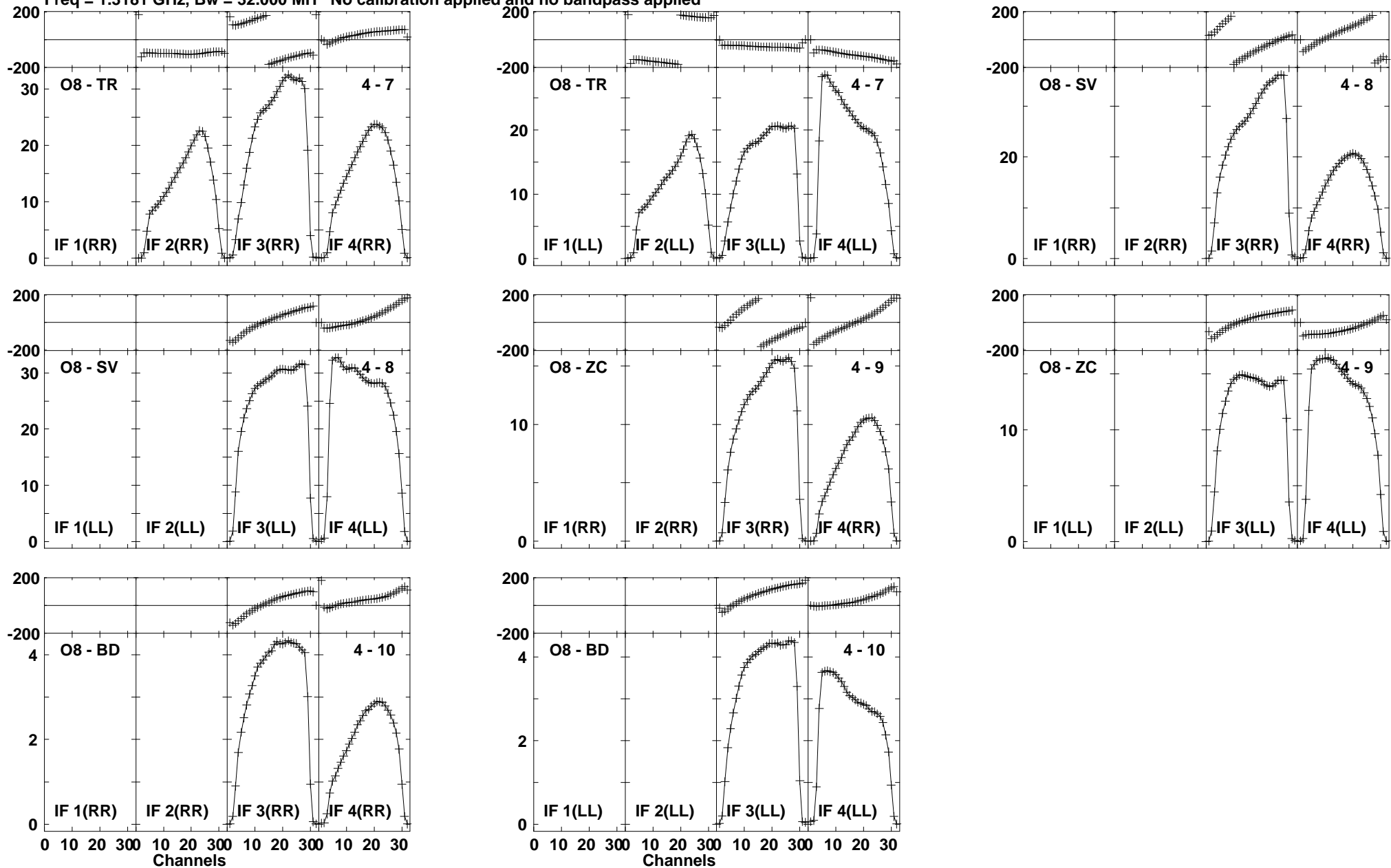

Lower frame: Milli Ampl Jy Top frame: Phas deg
 Vector averaged cross-power spectrum Baseline: O8 (04) - TR (07)
 Timerange: 00/09:18:43 to 00/09:28:39

Plot file version 114 created 20-NOV-2015 13:43:57

4C39.25 EO013 1.UVDATA.1

Freq = 1.3181 GHz, Bw = 32.000 MH No calibration applied and no bandpass applied

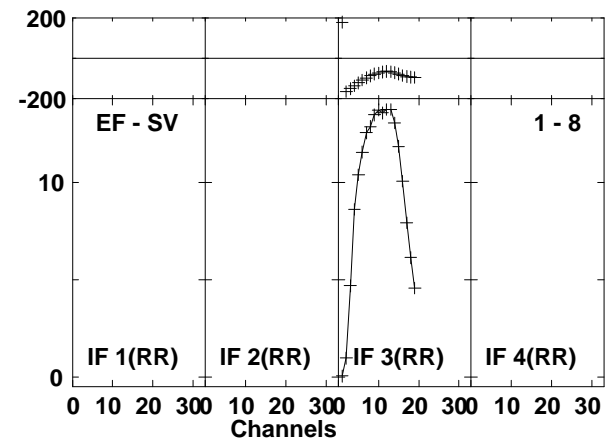
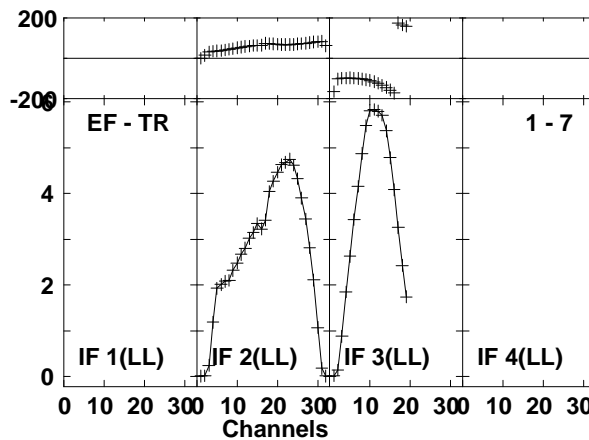
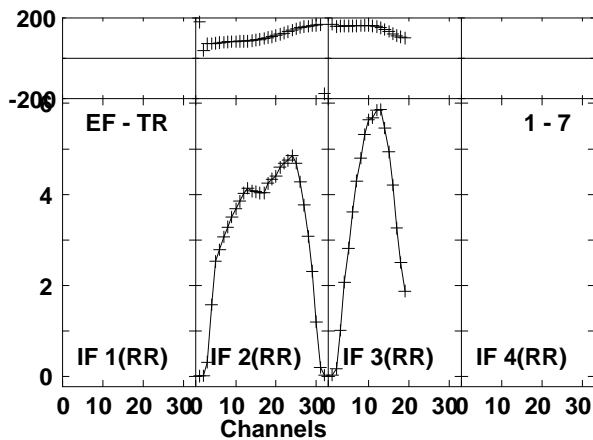
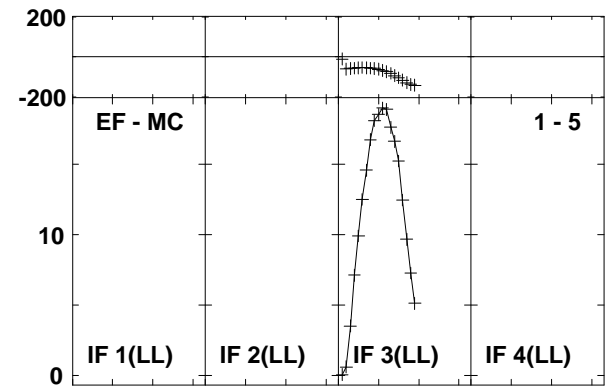
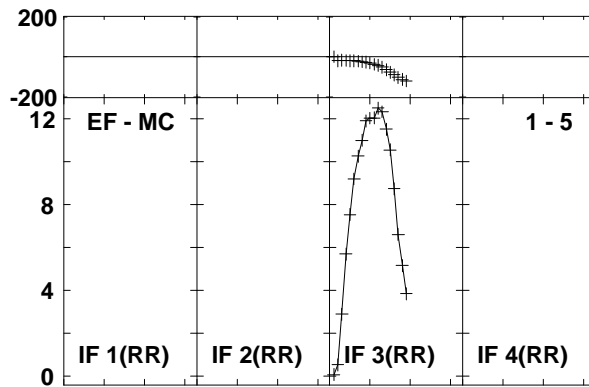
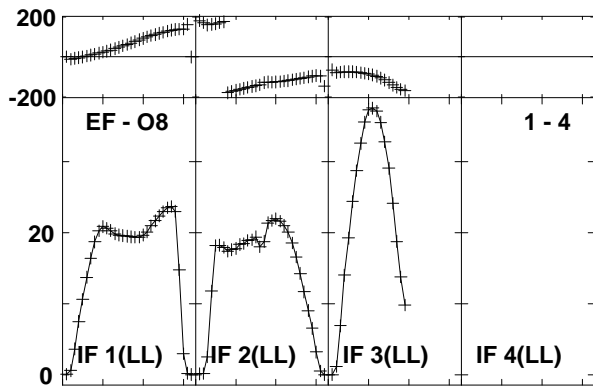
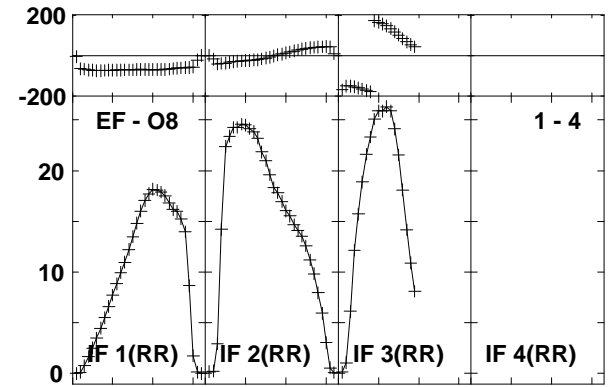
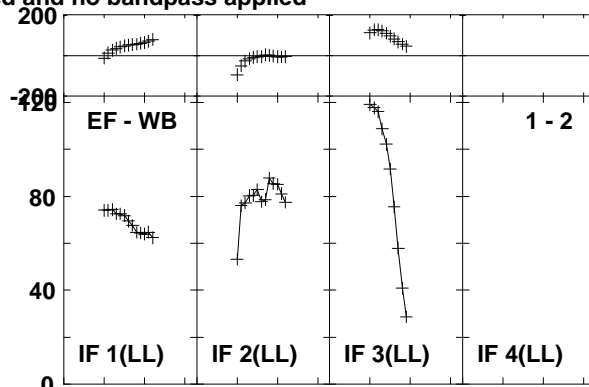
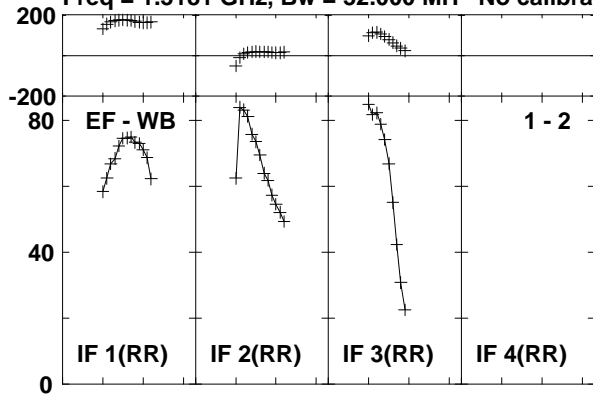

Lower frame: Milli Ampl Jy Top frame: Phas deg
Vector averaged cross-power spectrum Baseline: EF (01) - WB (02)
Timerange: 00/09:34:13 to 00/09:44:08

Plot file version 115 created 20-NOV-2015 13:43:57
 4C39.25 EO013 1.UVDATA.1
 Freq = 1.3181 GHz, Bw = 32.000 MH No calibration applied and no bandpass applied

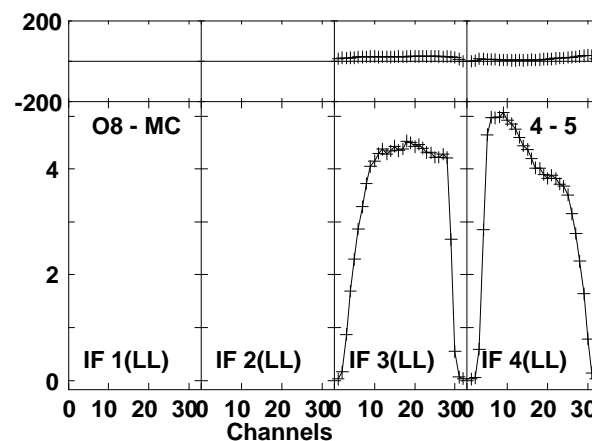
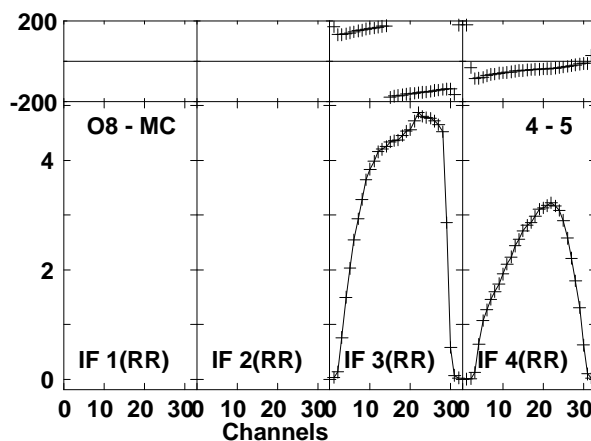
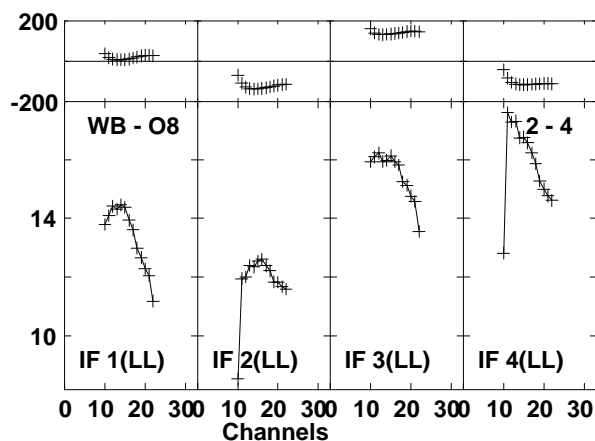
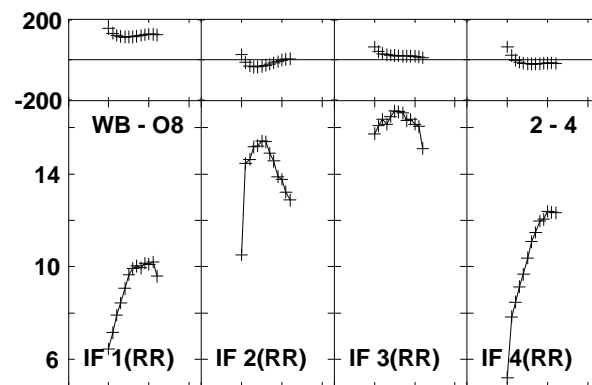
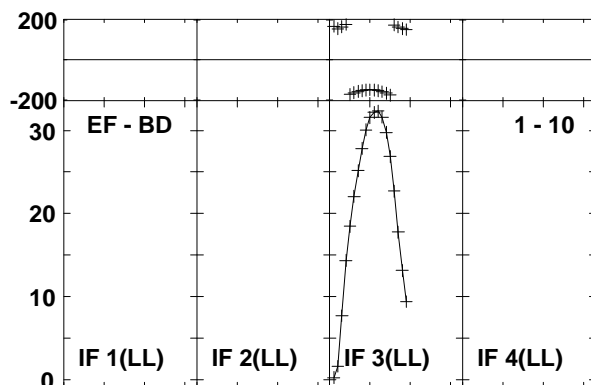
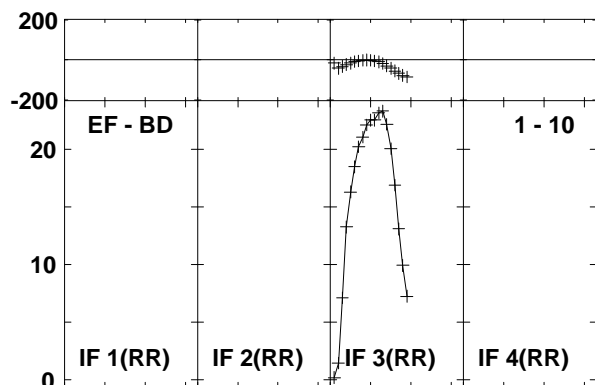
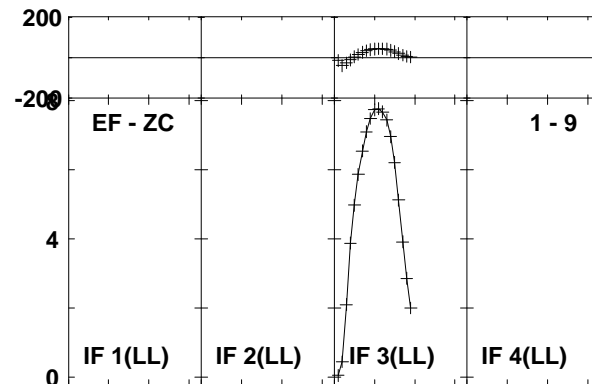
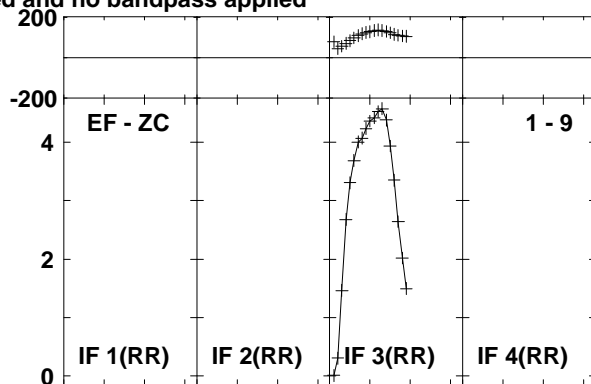
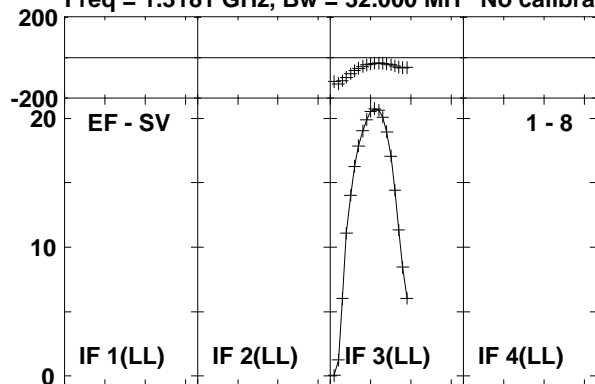

Lower frame: Milli Ampl Jy Top frame: Phas deg
 Vector averaged cross-power spectrum Baseline: EF (01) - SV (08)
 Timerange: 00/09:34:13 to 00/09:44:08

Plot file version 116 created 20-NOV-2015 13:43:57

4C39.25 EO013 1.UVDATA.1

Freq = 1.3181 GHz, Bw = 32.000 MH No calibration applied and no bandpass applied

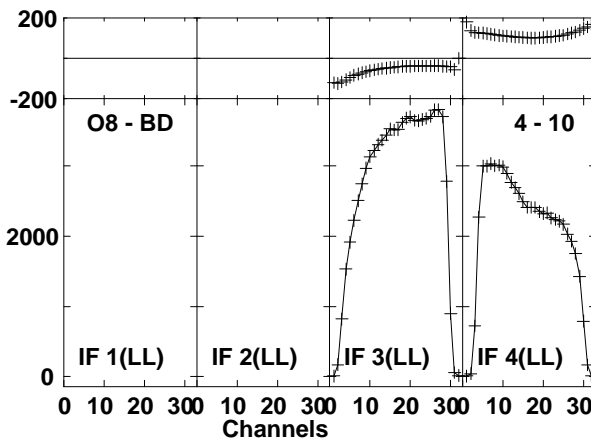
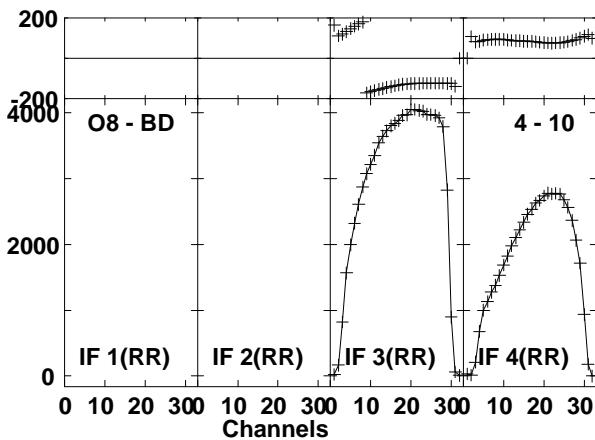
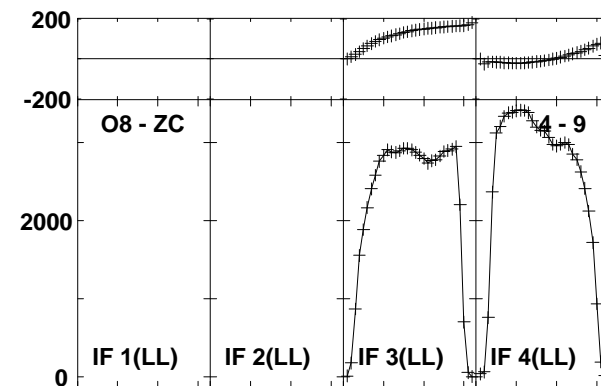
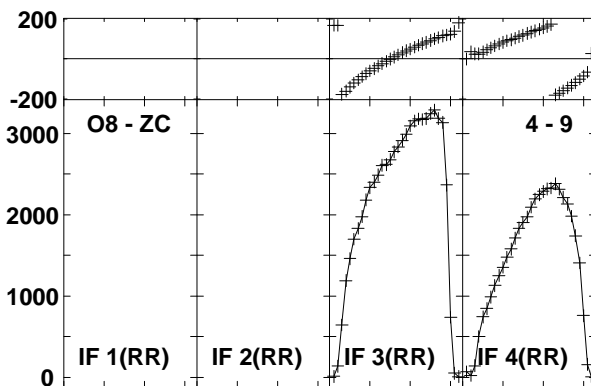
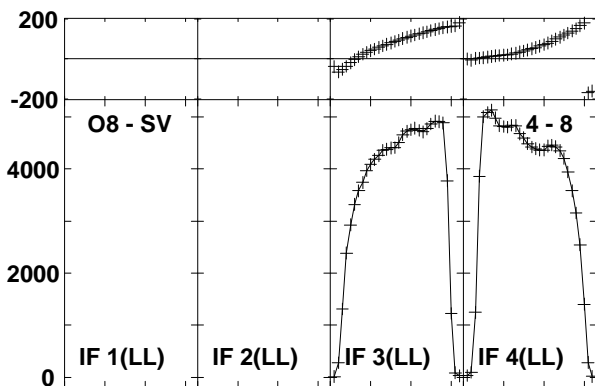
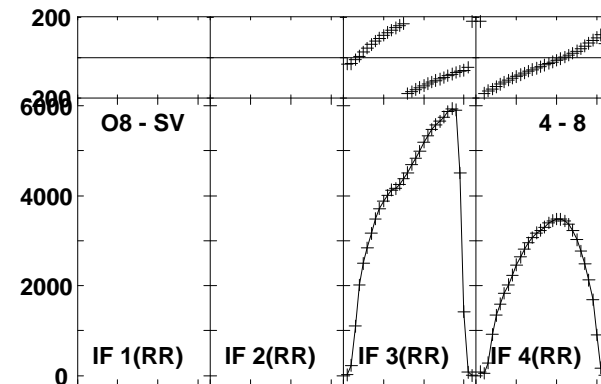
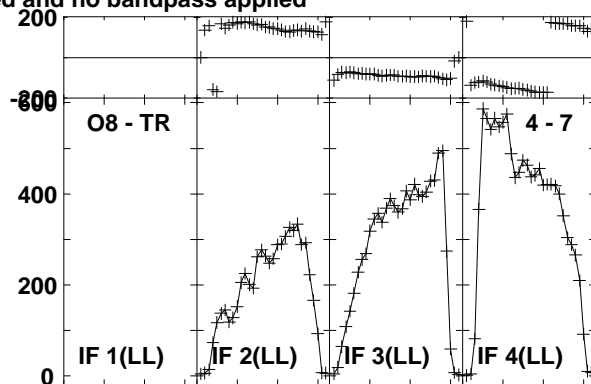
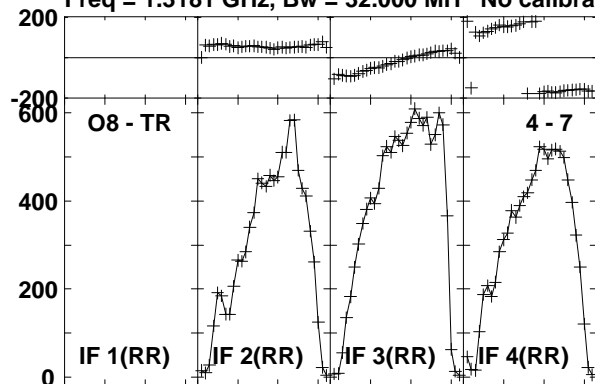

Lower frame: Micro Ampl Jy Top frame: Phas deg
Vector averaged cross-power spectrum Baseline: O8 (04) - TR (07)
Timerange: 00/09:34:13 to 00/09:44:08

Plot file version 117 created 20-NOV-2015 13:43:58

4C39.25 EO013 1.UVDATA.1

Freq = 1.3181 GHz, Bw = 32.000 MH No calibration applied and no bandpass applied

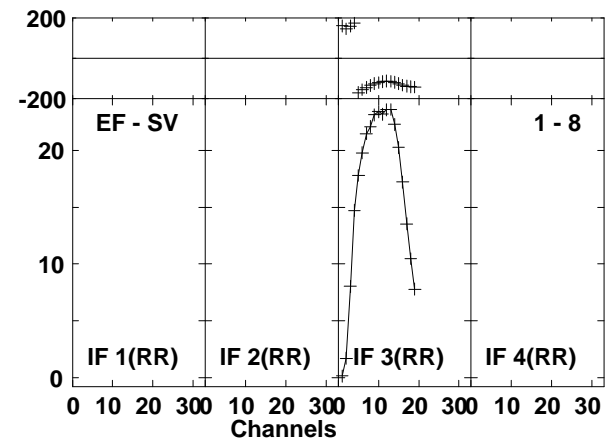
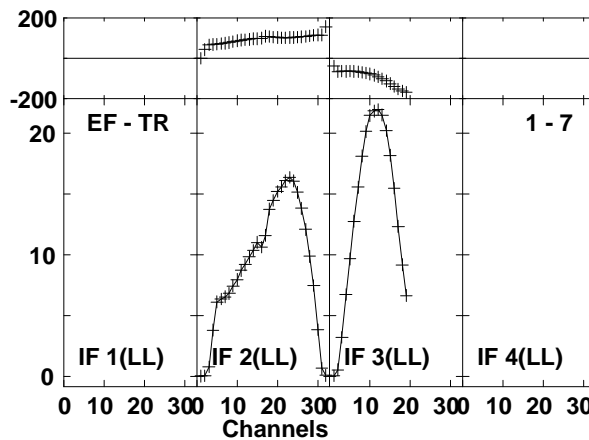
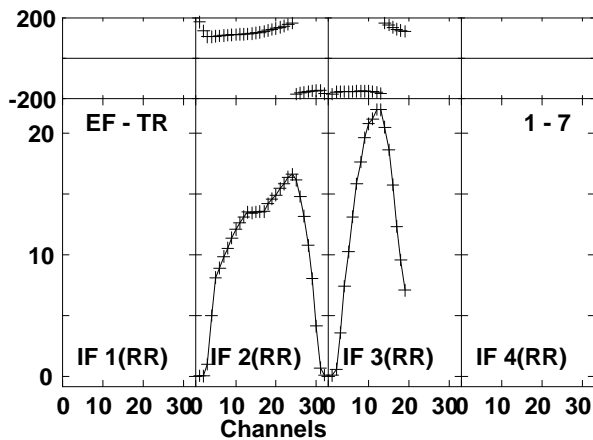
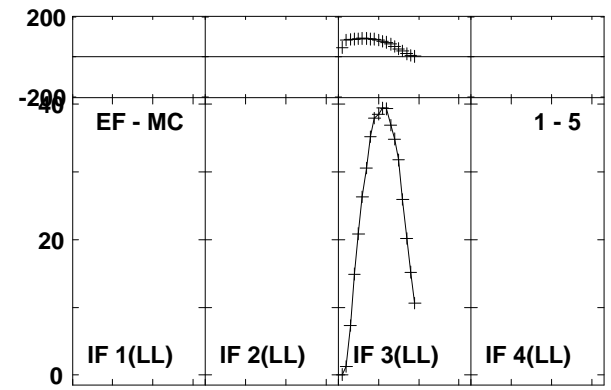
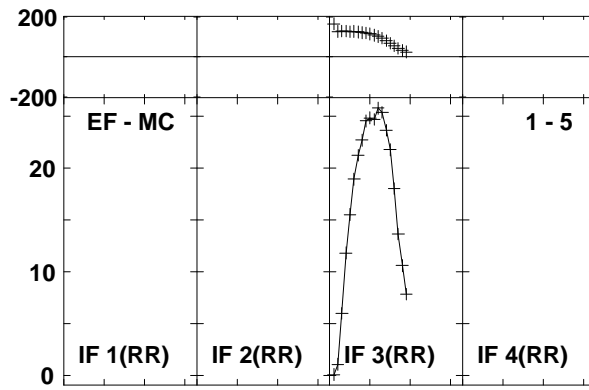
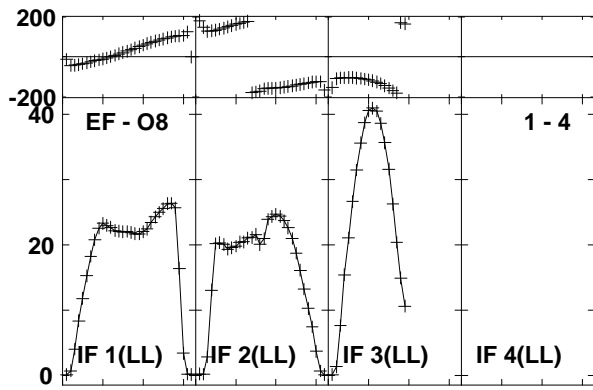
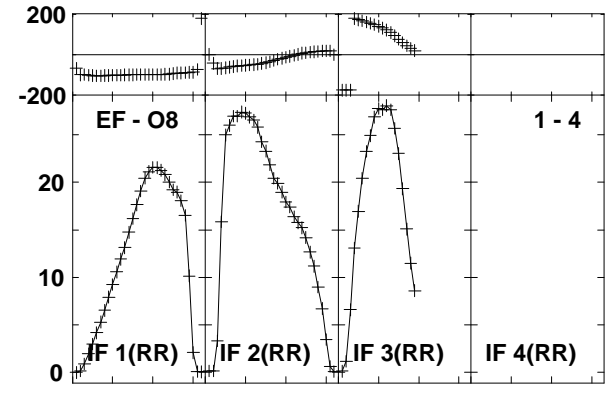
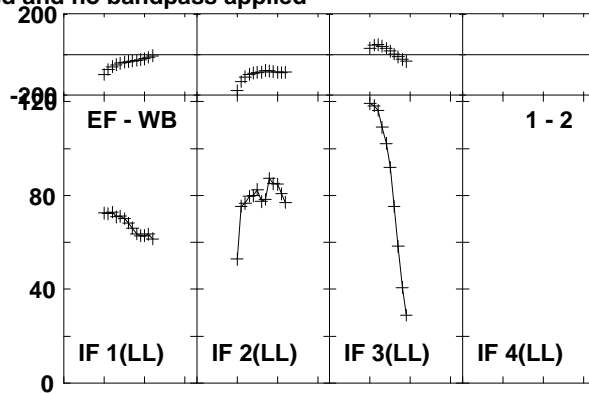
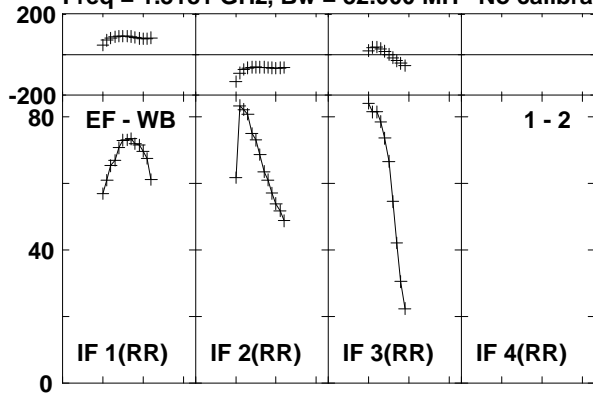

Lower frame: Milli Ampl Jy Top frame: Phas deg
Vector averaged cross-power spectrum Baseline: EF (01) - WB (02)
Timerange: 00/09:44:43 to 00/09:49:39

Plot file version 118 created 20-NOV-2015 13:43:58
 4C39.25 EO013 1.UVDATA.1
 Freq = 1.3181 GHz, Bw = 32.000 MH No calibration applied and no bandpass applied

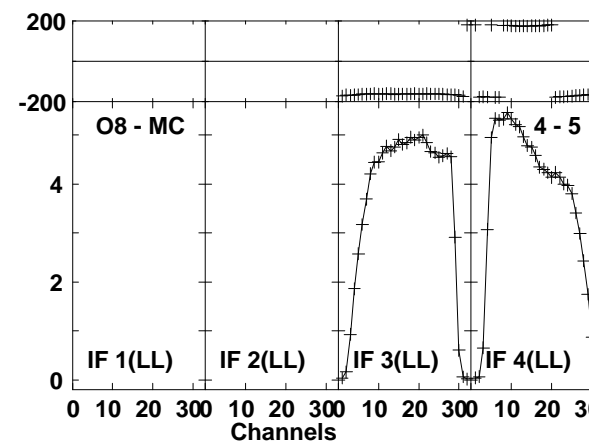
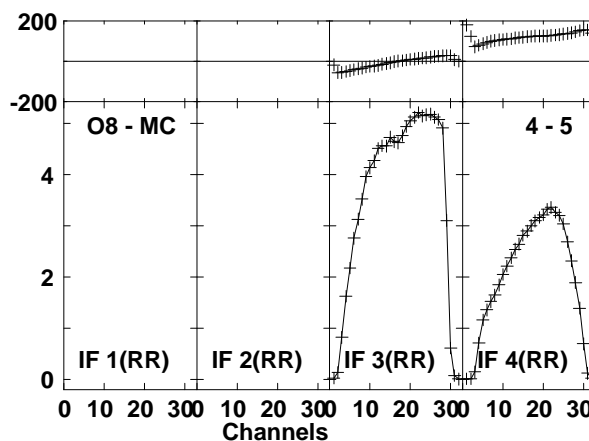
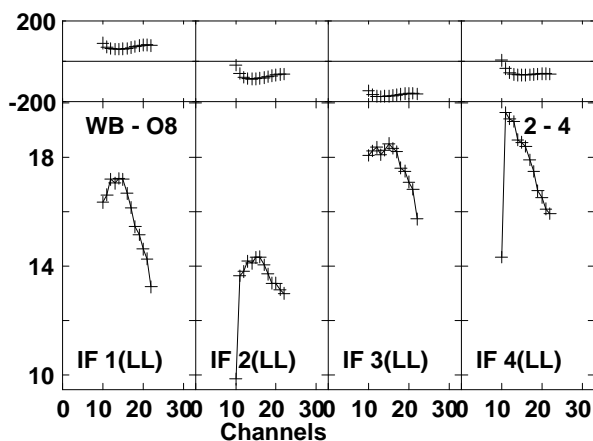
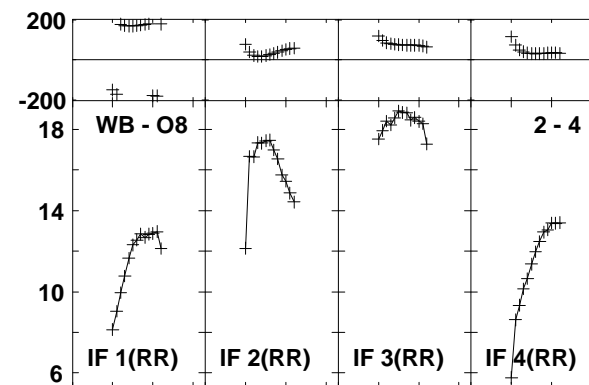
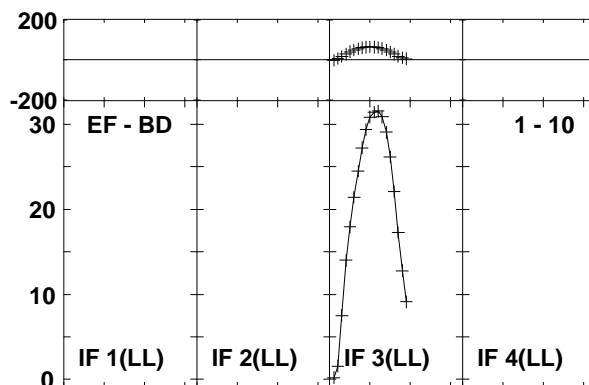
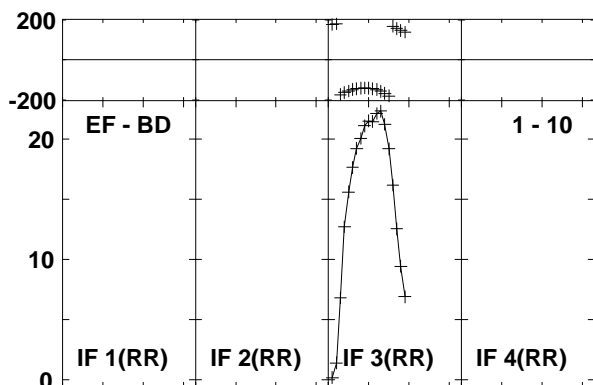
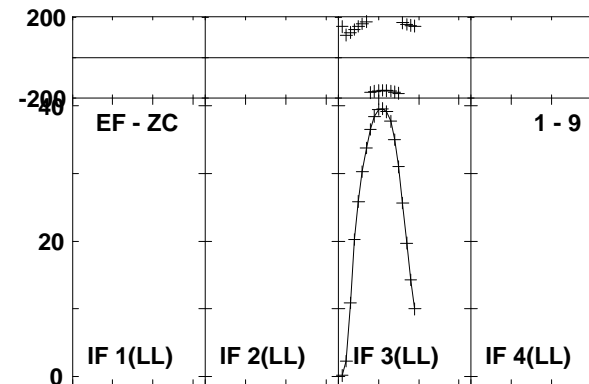
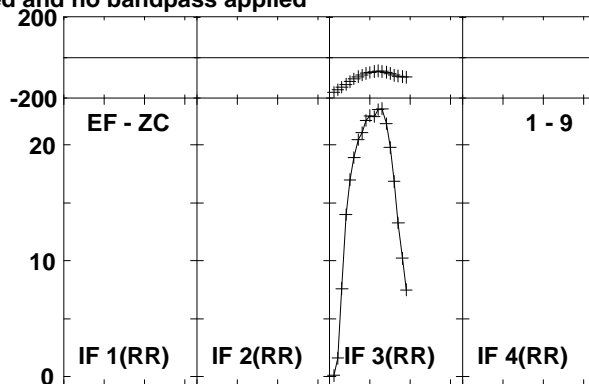
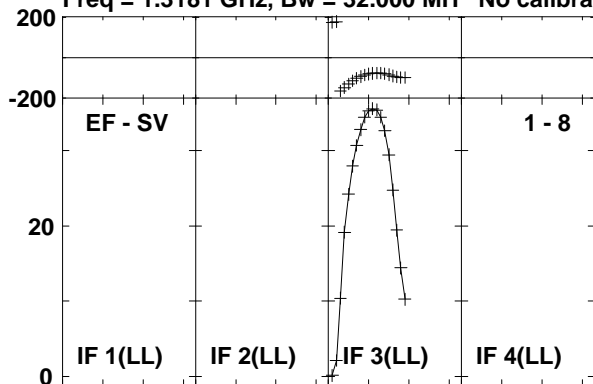

Lower frame: Milli Ampl Jy Top frame: Phas deg
 Vector averaged cross-power spectrum Baseline: EF (01) - SV (08)
 Timerange: 00/09:44:43 to 00/09:49:39

Plot file version 119 created 20-NOV-2015 13:43:58

4C39.25 EO013 1.UVDATA.1

Freq = 1.3181 GHz, Bw = 32.000 MH No calibration applied and no bandpass applied

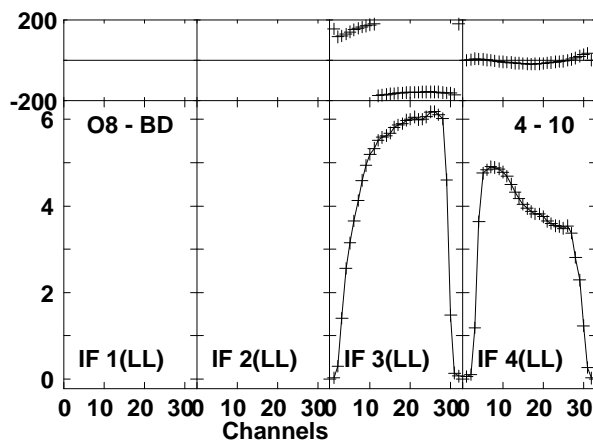
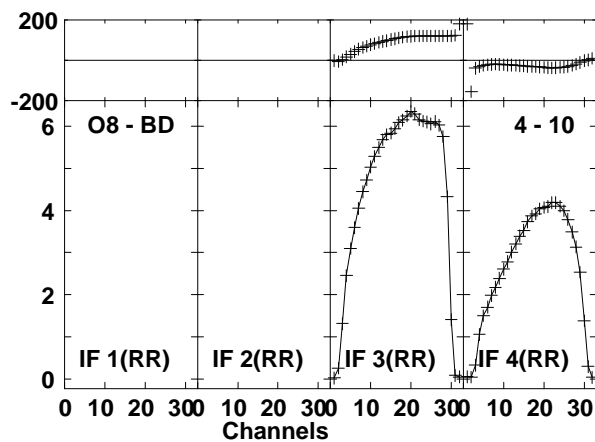
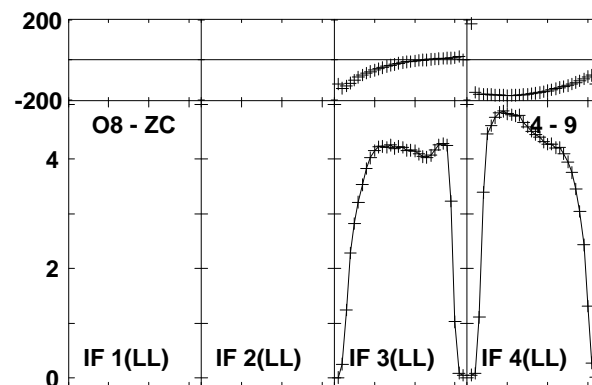
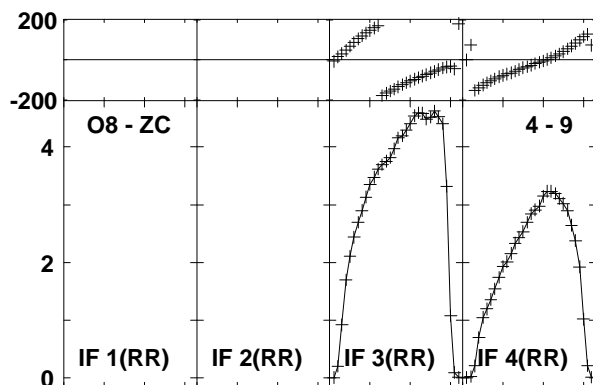
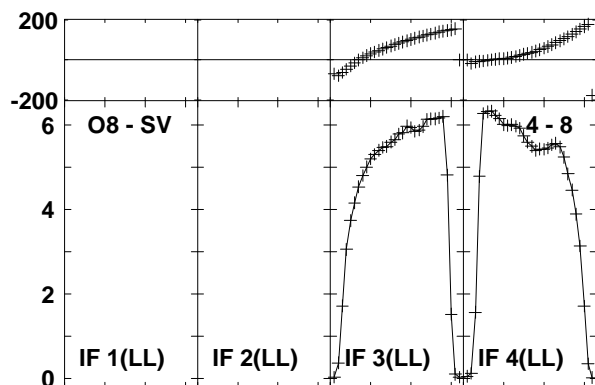
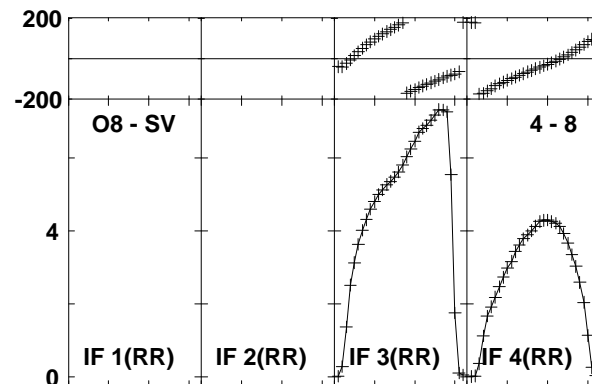
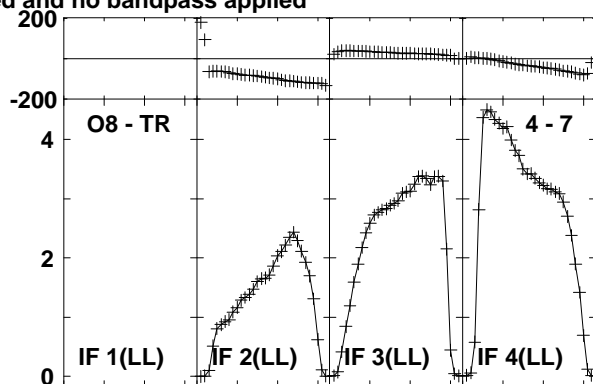
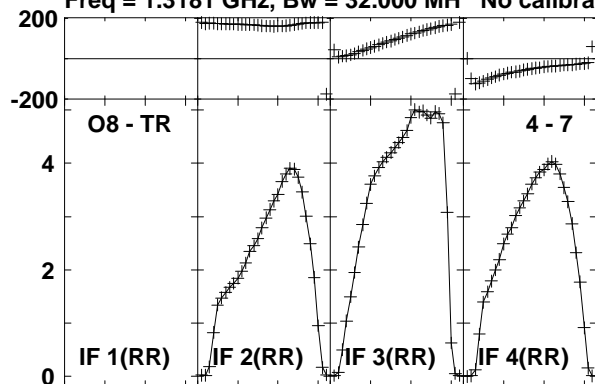

Lower frame: Milli Ampl Jy Top frame: Phas deg
Vector averaged cross-power spectrum Baseline: O8 (04) - TR (07)
Timerange: 00/09:44:43 to 00/09:49:39

Plot file version 120 created 20-NOV-2015 13:43:58

3C84 EO013 1.UVDATA.1

Freq = 1.3181 GHz, Bw = 32.000 MH No calibration applied and no bandpass applied

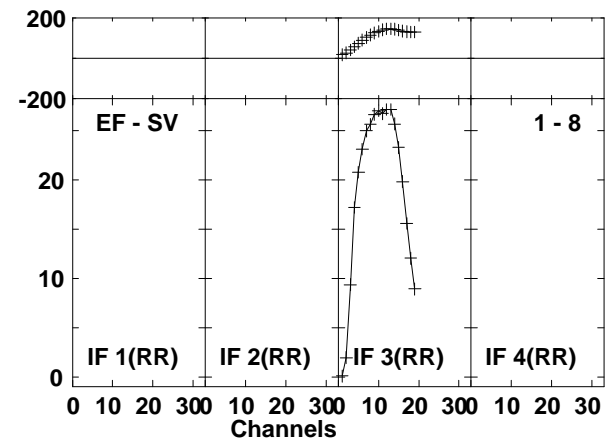
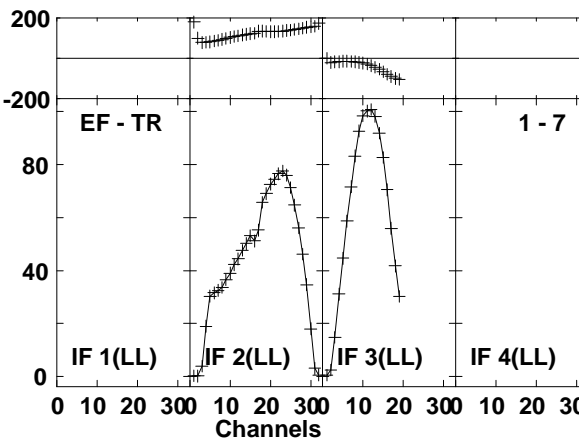
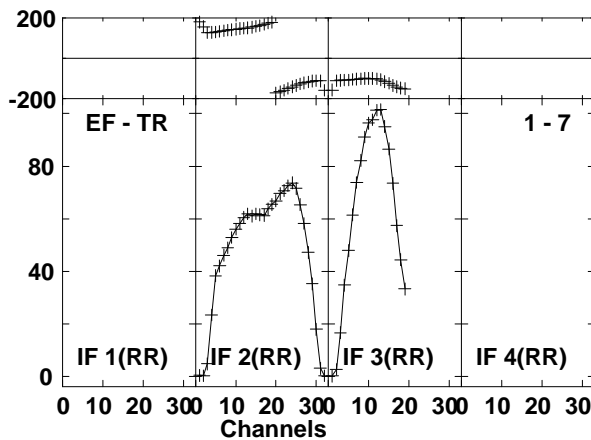
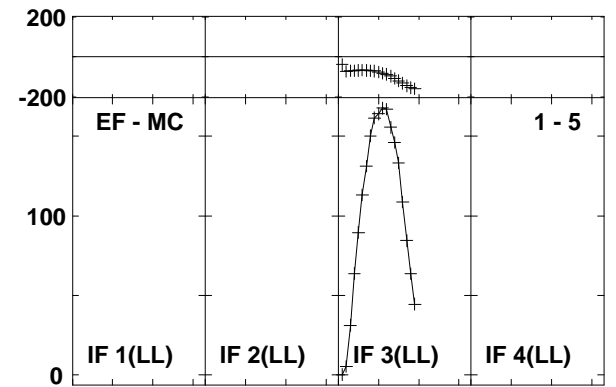
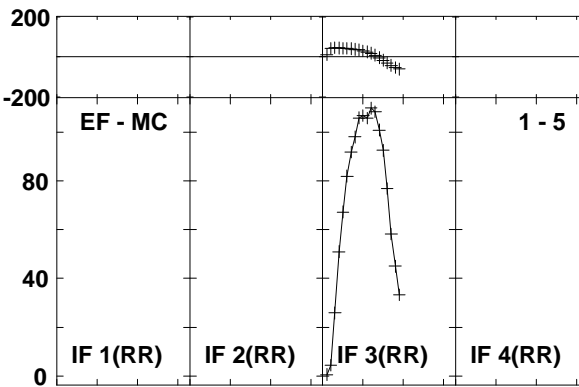
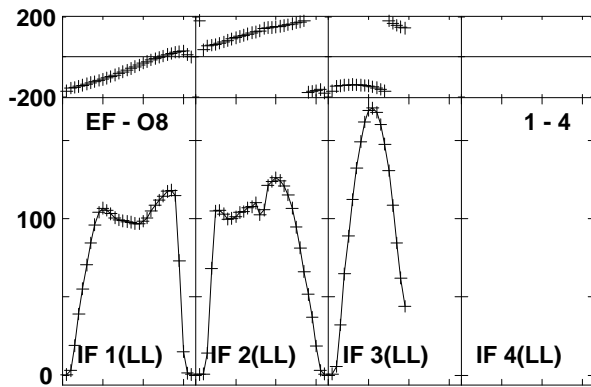
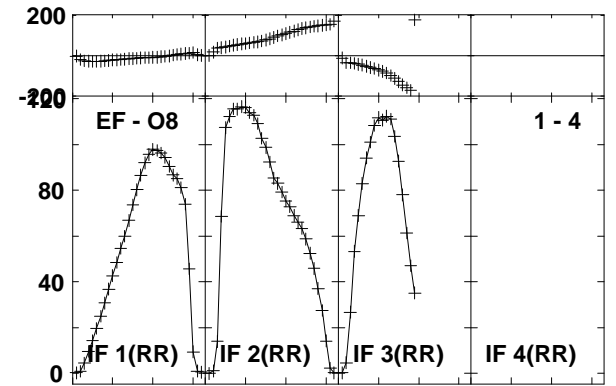
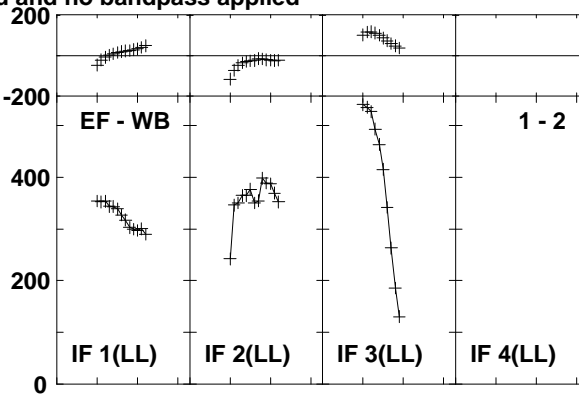
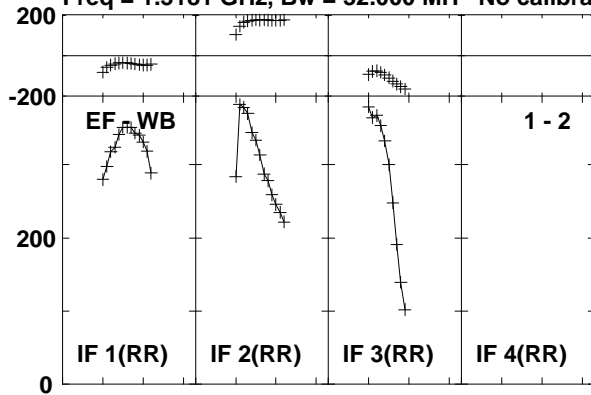

Lower frame: Milli Ampl Jy Top frame: Phas deg
Vector averaged cross-power spectrum Baseline: EF (01) - WB (02)
Timerange: 00/09:55:13 to 00/10:05:08

Plot file version 121 created 20-NOV-2015 13:43:58
 3C84 EO013 1.UVDATA.1
 Freq = 1.3181 GHz, Bw = 32.000 MH No calibration applied and no bandpass applied

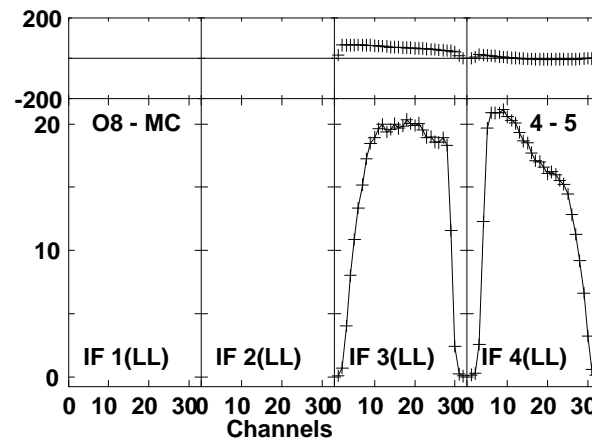
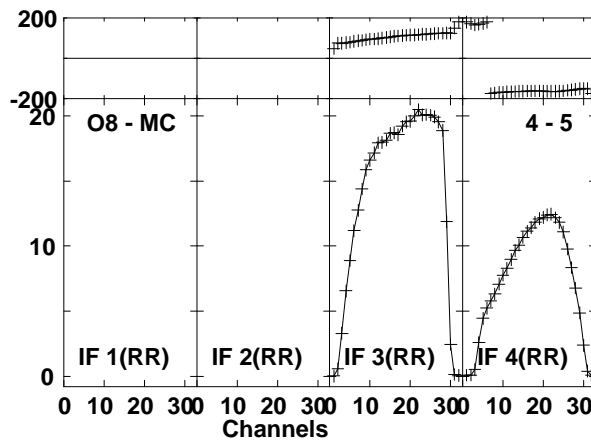
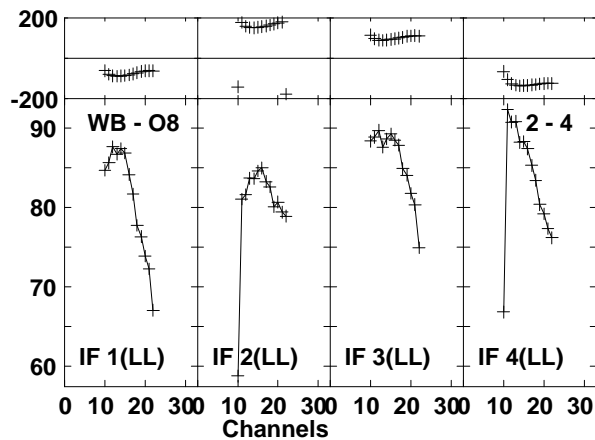
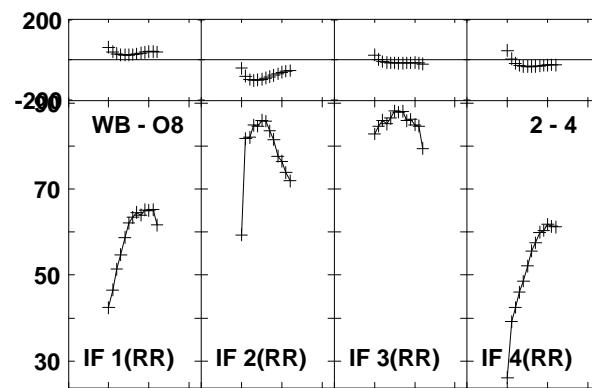
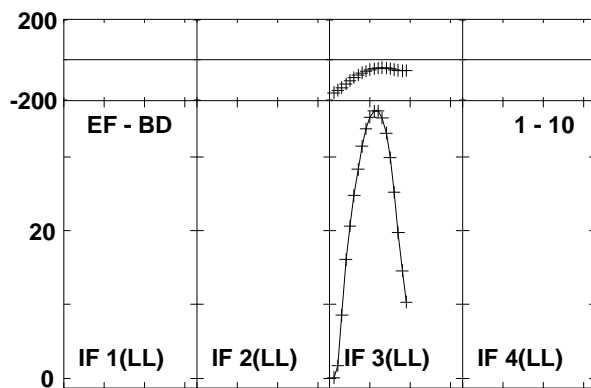
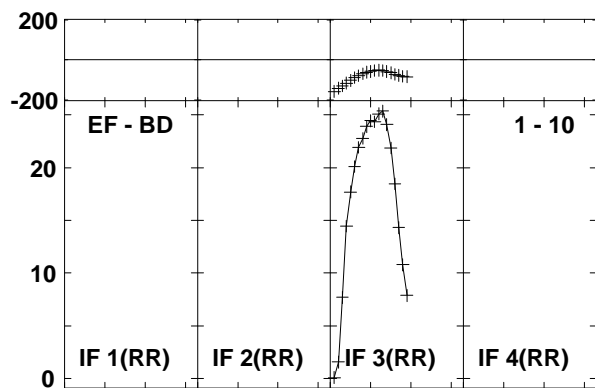
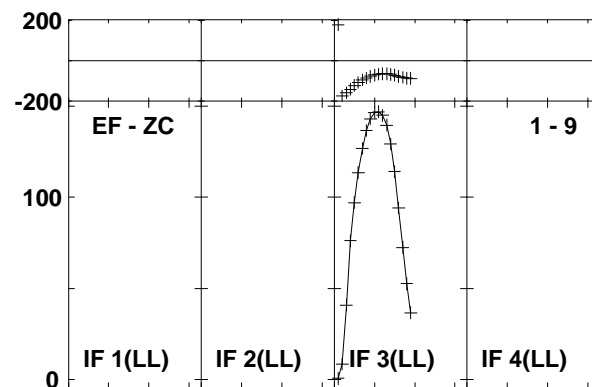
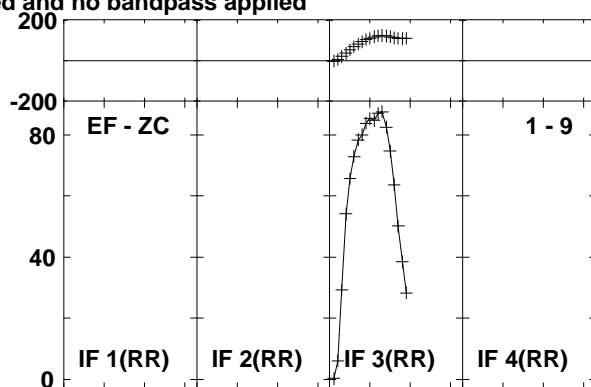
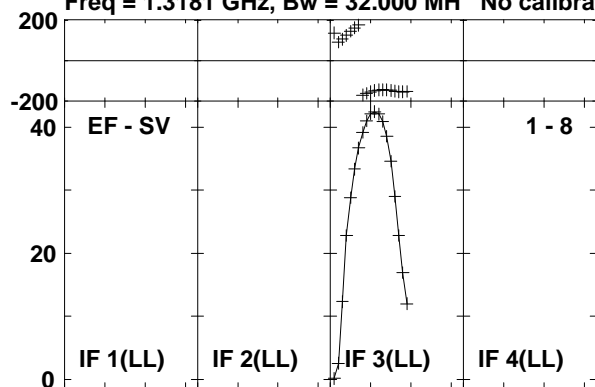

Lower frame: Milli Ampl Jy Top frame: Phas deg
 Vector averaged cross-power spectrum Baseline: EF (01) - SV (08)
 Timerange: 00/09:55:13 to 00/10:05:08

Plot file version 122 created 20-NOV-2015 13:43:58
 3C84 EO013 1.UVDATA.1
 Freq = 1.3181 GHz, Bw = 32.000 MH No calibration applied and no bandpass applied

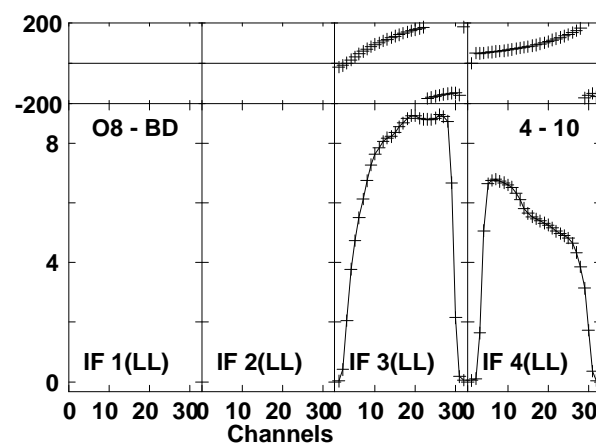
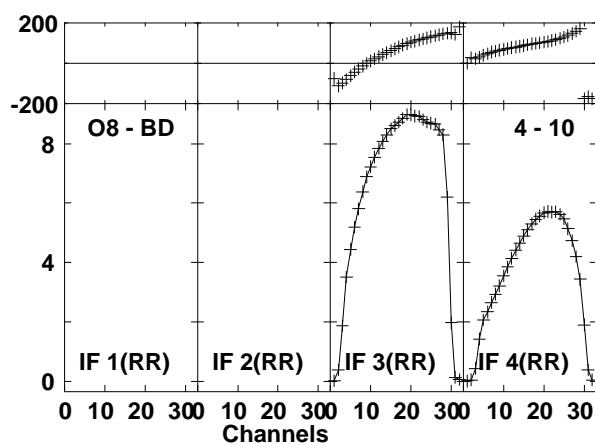
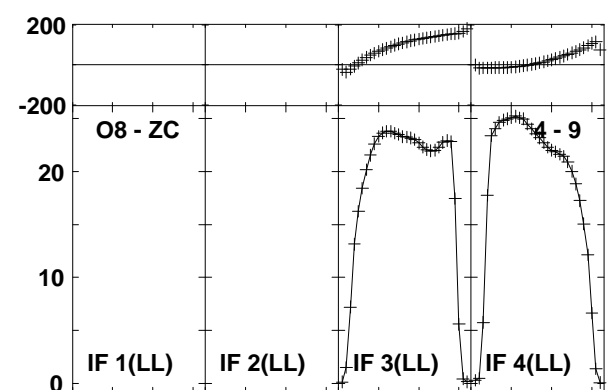
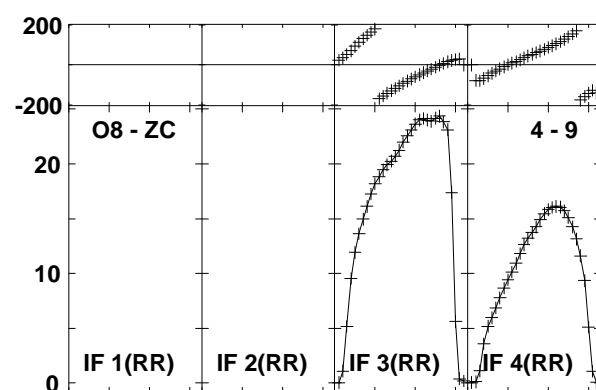
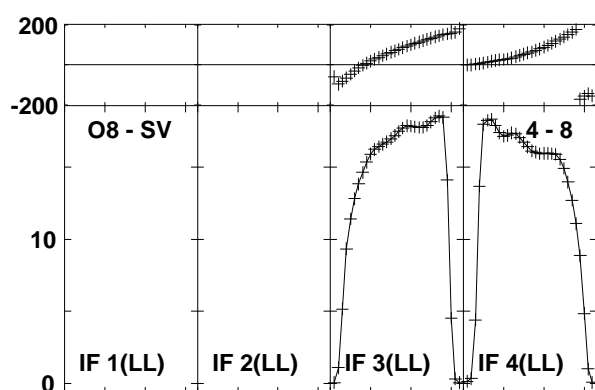
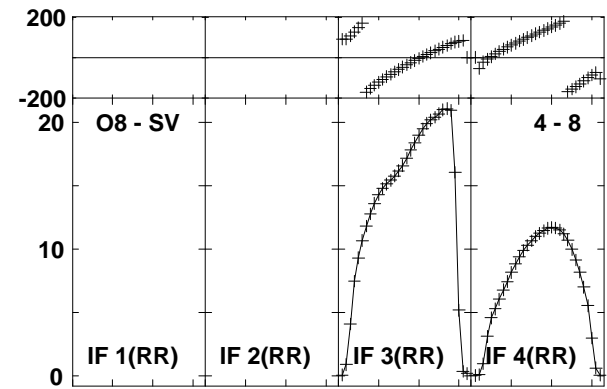
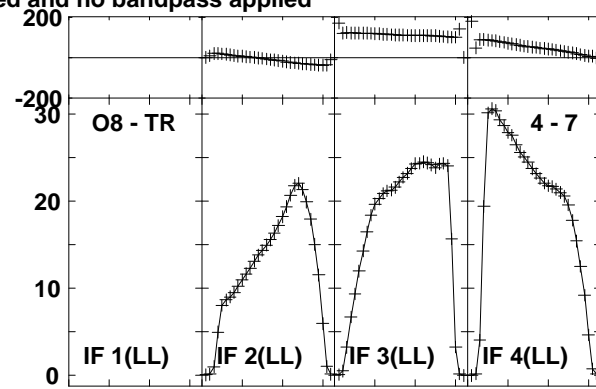
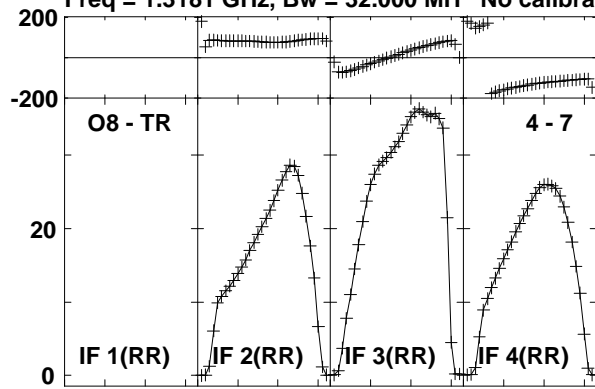

Lower frame: Milli Ampl Jy Top frame: Phas deg
 Vector averaged cross-power spectrum Baseline: O8 (04) - TR (07)
 Timerange: 00/09:55:13 to 00/10:05:08

Plot file version 123 created 20-NOV-2015 13:43:58

3C84 EO013 1.UVDATA.1

Freq = 1.3181 GHz, Bw = 32.000 MH No calibration applied and no bandpass applied

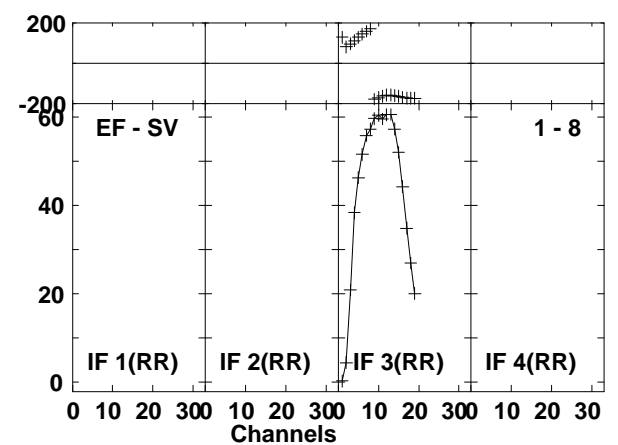
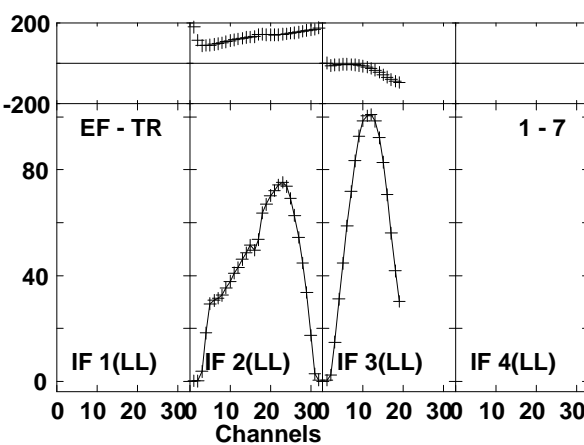
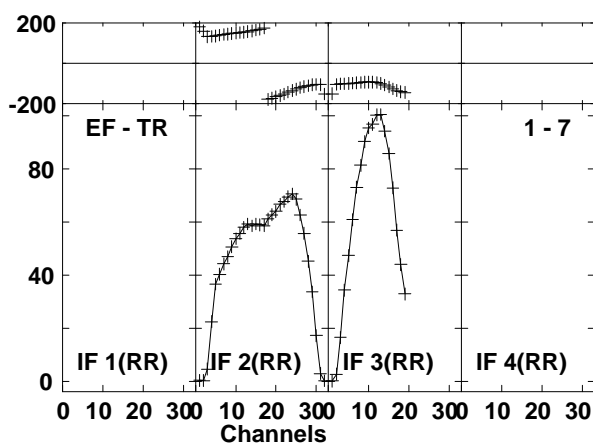
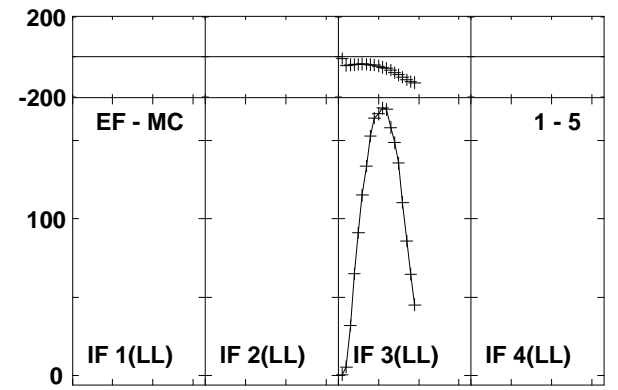
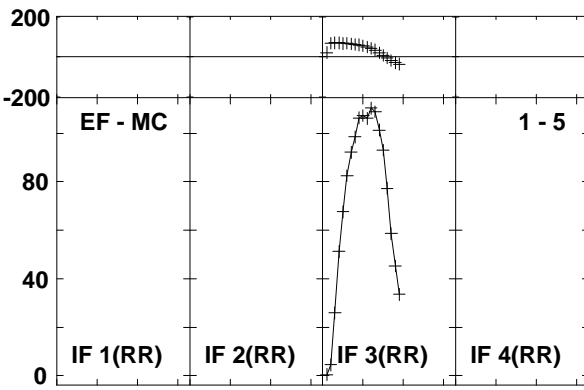
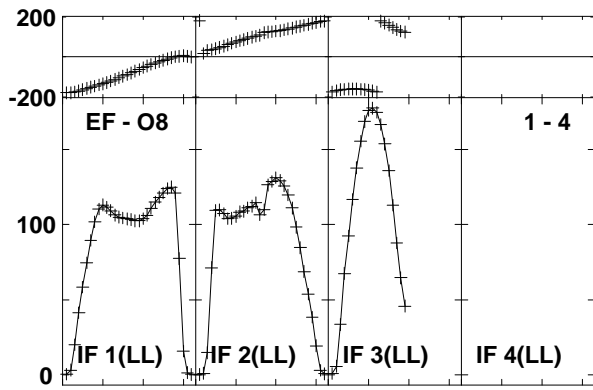
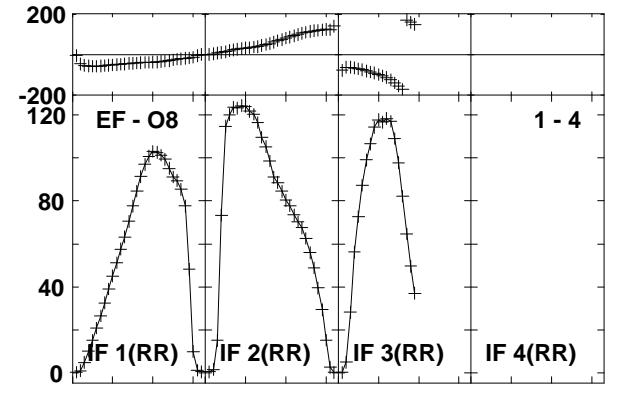
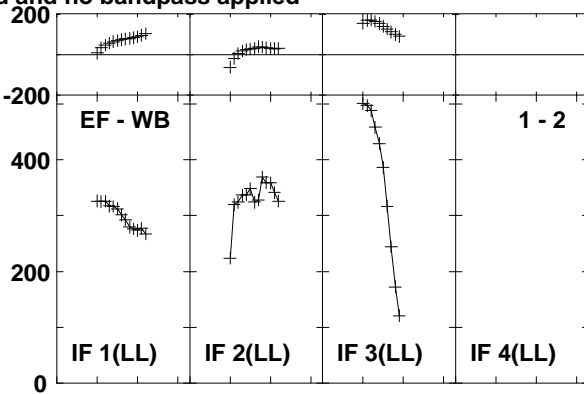
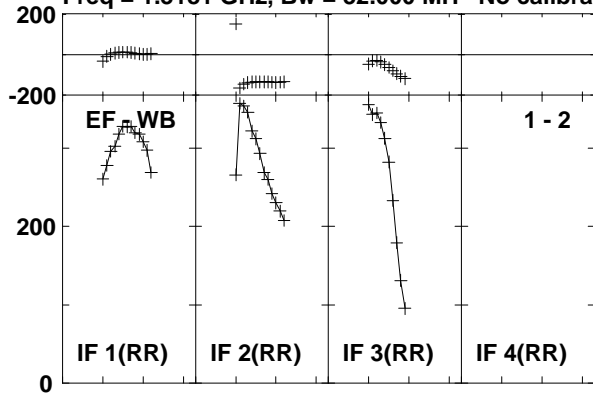

Lower frame: Milli Ampl Jy Top frame: Phas deg
Vector averaged cross-power spectrum Baseline: EF (01) - WB (02)
Timerange: 00/10:05:43 to 00/10:15:39

Plot file version 124 created 20-NOV-2015 13:43:58
 3C84 EO013 1.UVDATA.1
 Freq = 1.3181 GHz, Bw = 32.000 MH No calibration applied and no bandpass applied

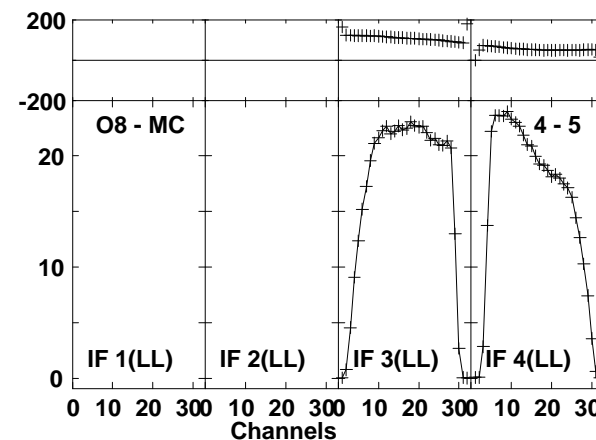
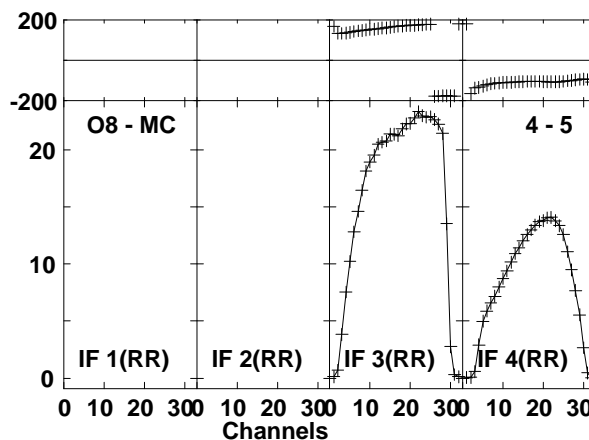
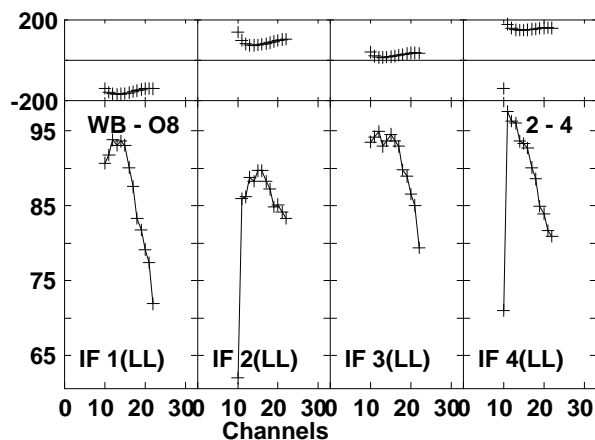
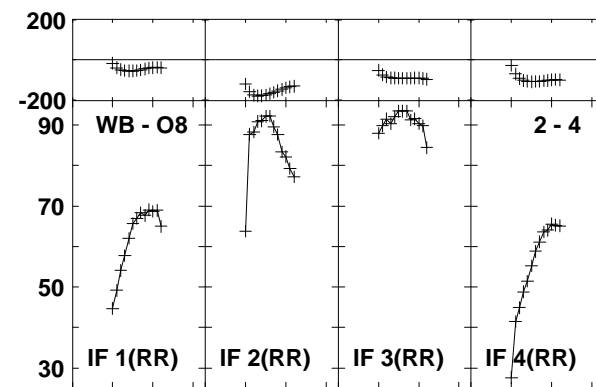
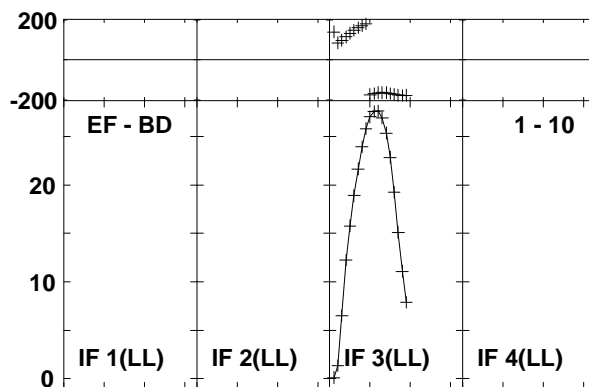
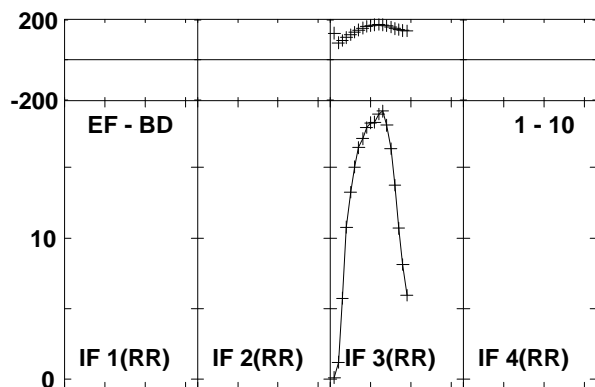
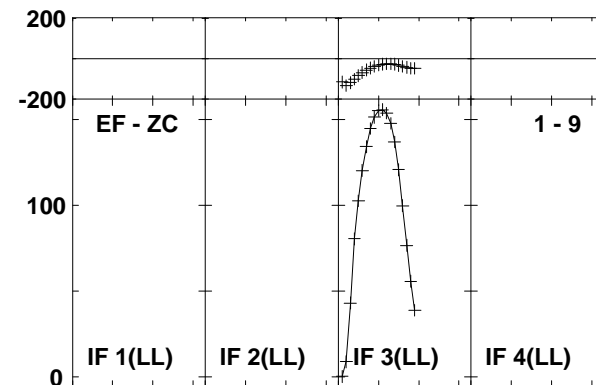
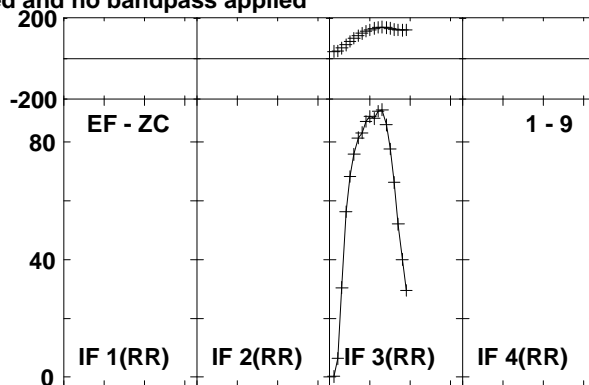
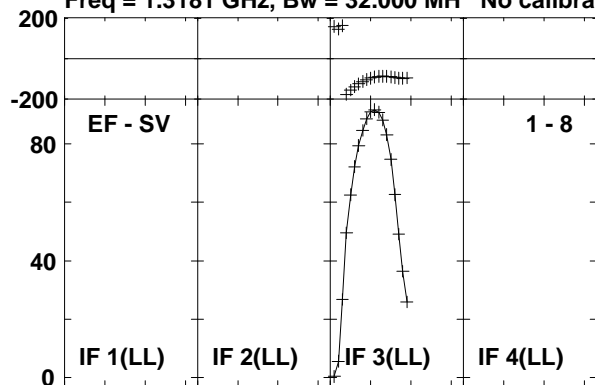

Lower frame: Milli Ampl Jy Top frame: Phas deg
 Vector averaged cross-power spectrum Baseline: EF (01) - SV (08)
 Timerange: 00/10:05:43 to 00/10:15:39

Plot file version 125 created 20-NOV-2015 13:43:58
 3C84 EO013 1.UVDATA.1
 Freq = 1.3181 GHz, Bw = 32.000 MH No calibration applied and no bandpass applied

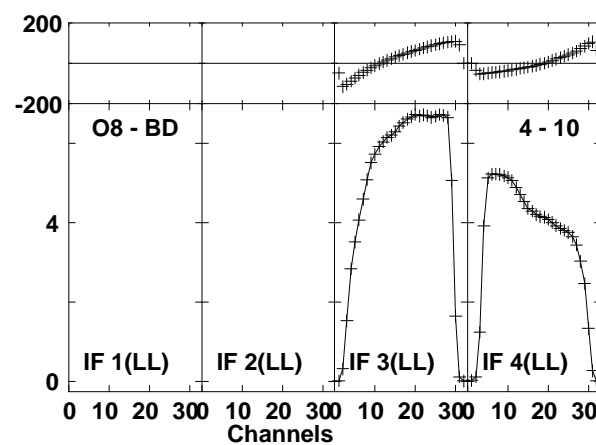
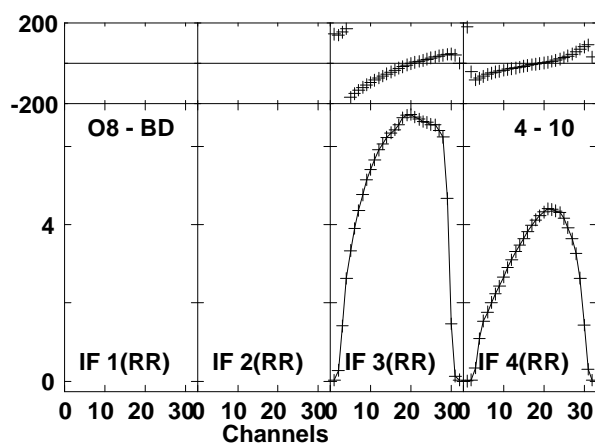
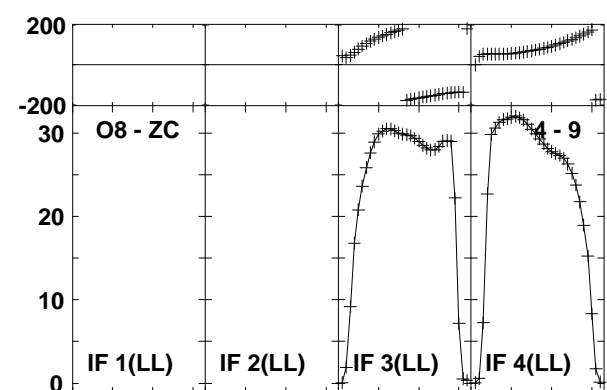
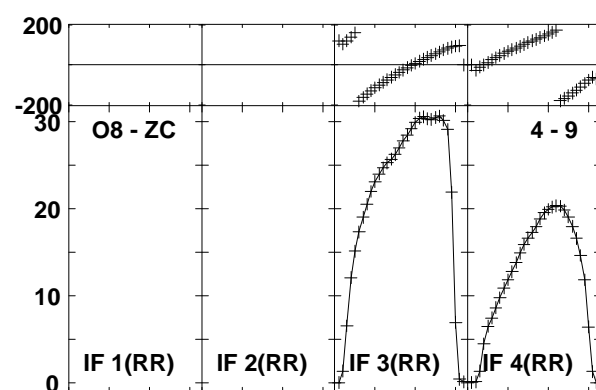
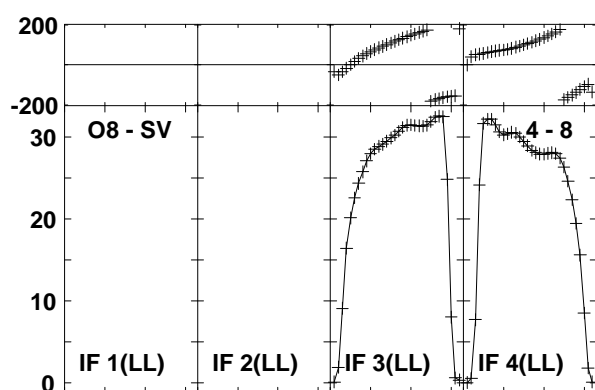
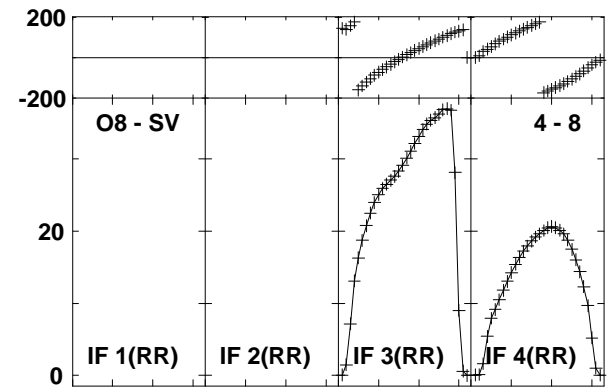
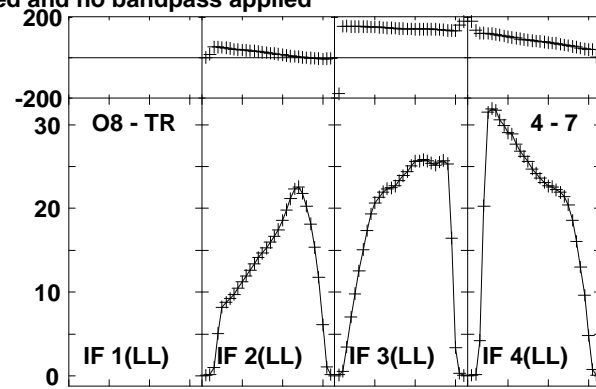
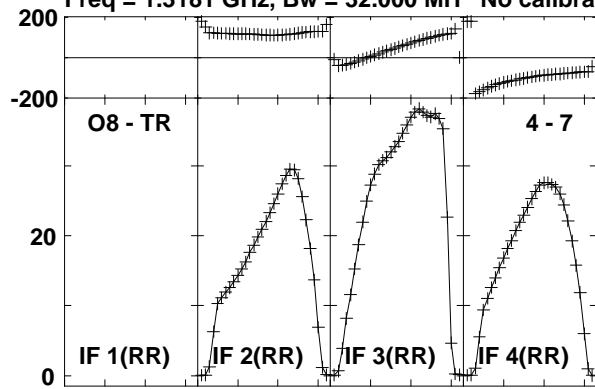

Lower frame: Milli Ampl Jy Top frame: Phas deg
 Vector averaged cross-power spectrum Baseline: O8 (04) - TR (07)
 Timerange: 00/10:05:43 to 00/10:15:39

Plot file version 126 created 20-NOV-2015 13:43:58
 3C84 EO013 1.UVDATA.1
 Freq = 1.3181 GHz, Bw = 32.000 MH No calibration applied and no bandpass applied

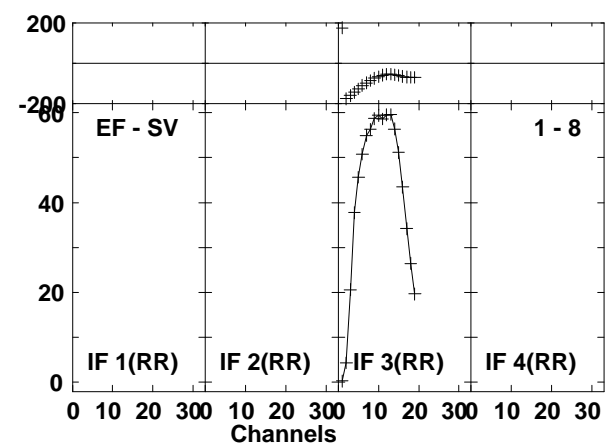
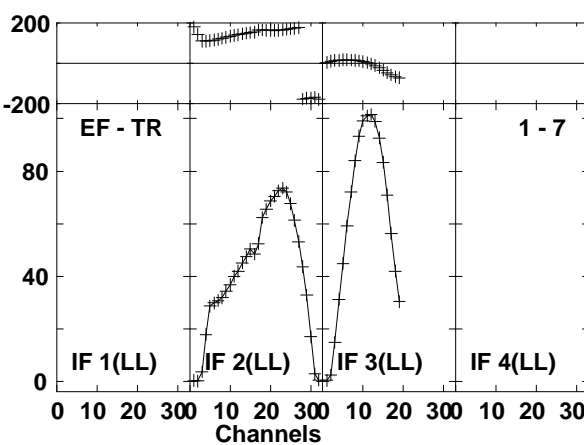
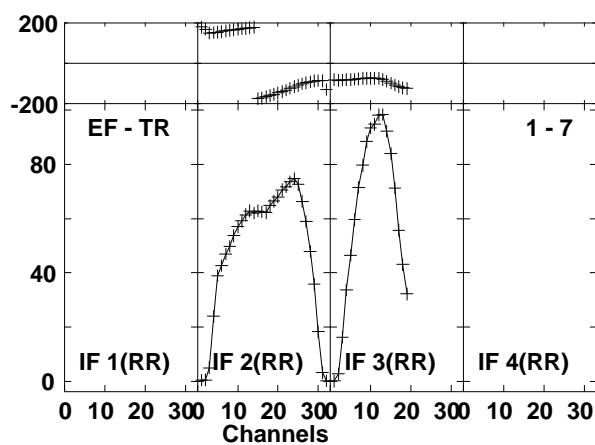
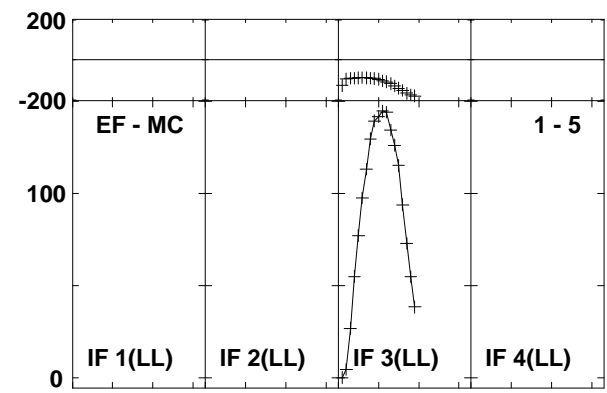
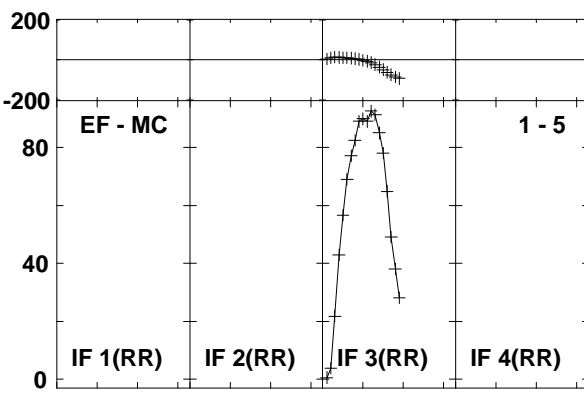
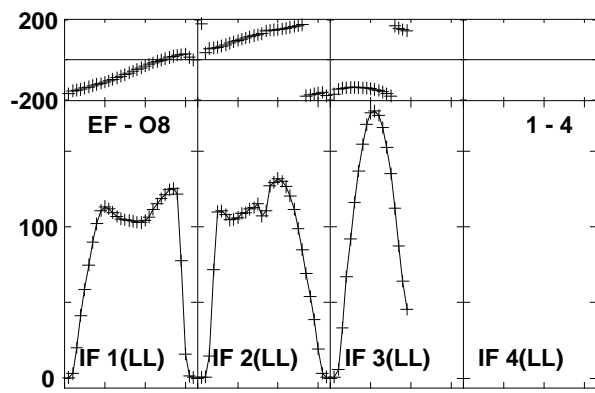
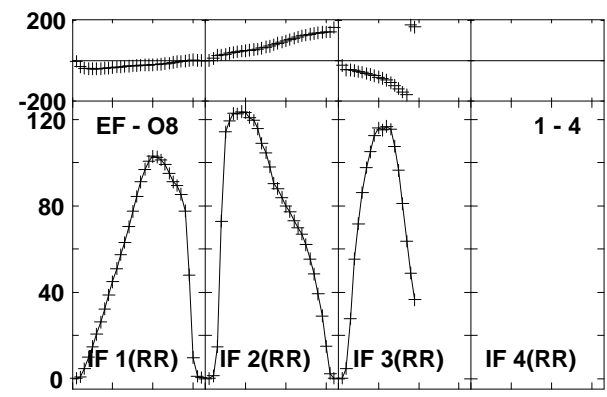
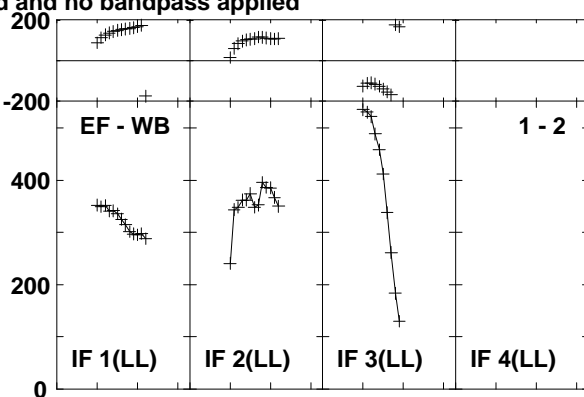
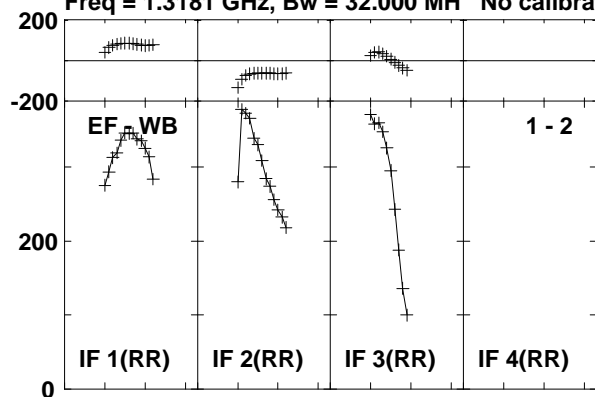

Lower frame: Milli Ampl Jy Top frame: Phas deg
 Vector averaged cross-power spectrum Baseline: EF (01) - WB (02)
 Timerange: 00/10:16:13 to 00/10:26:09

Plot file version 127 created 20-NOV-2015 13:43:58
 3C84 EO013 1.UVDATA.1
 Freq = 1.3181 GHz, Bw = 32.000 MH No calibration applied and no bandpass applied

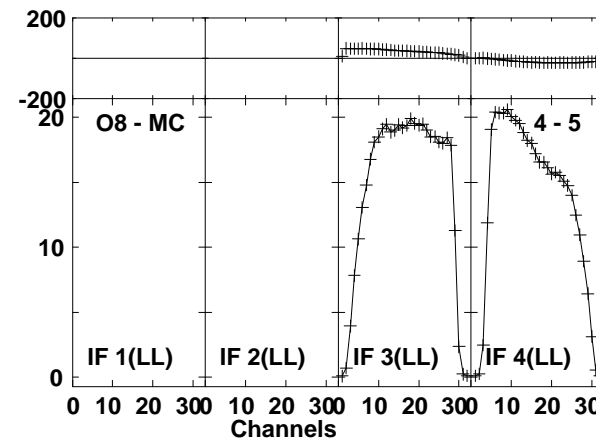
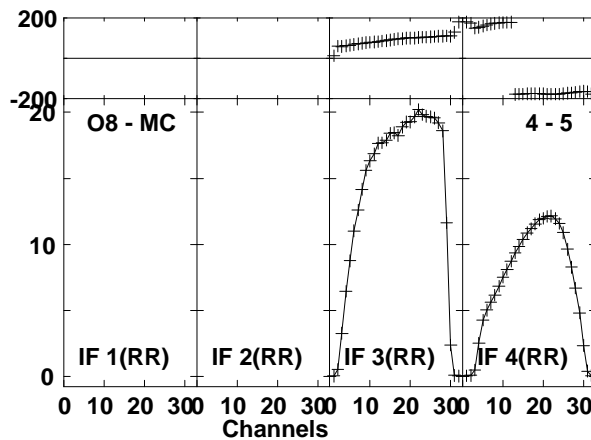
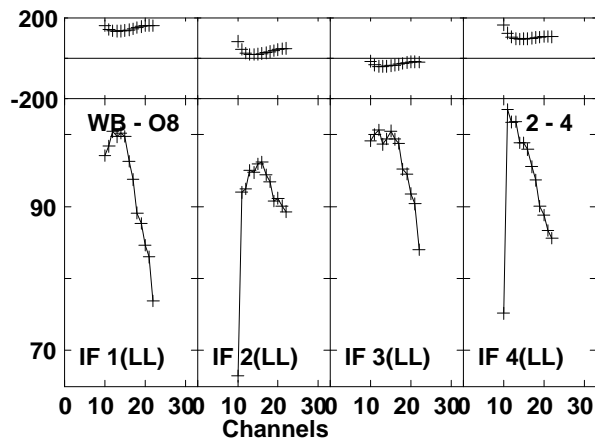
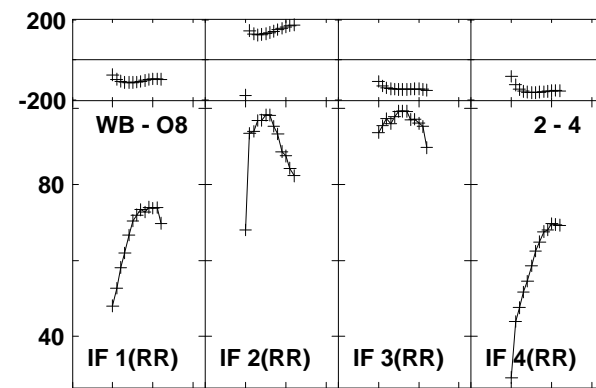
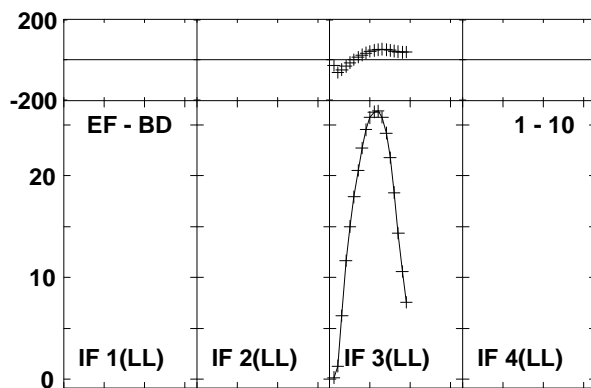
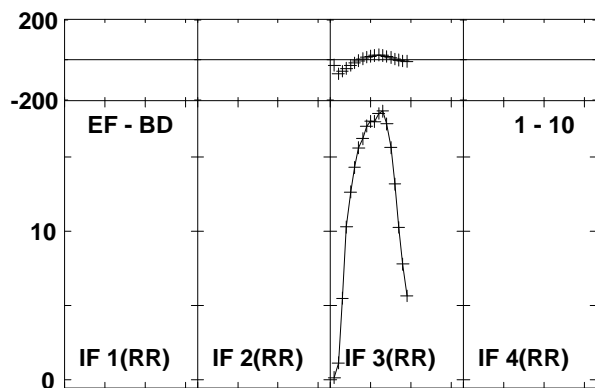
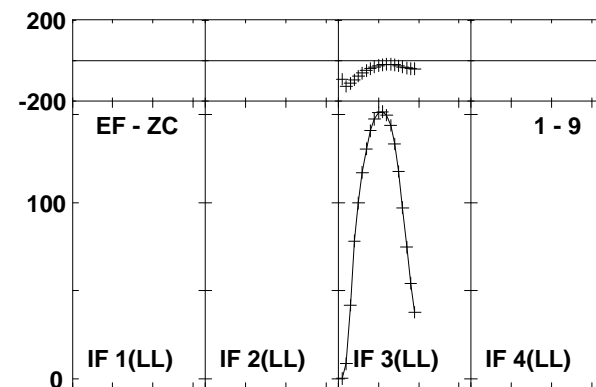
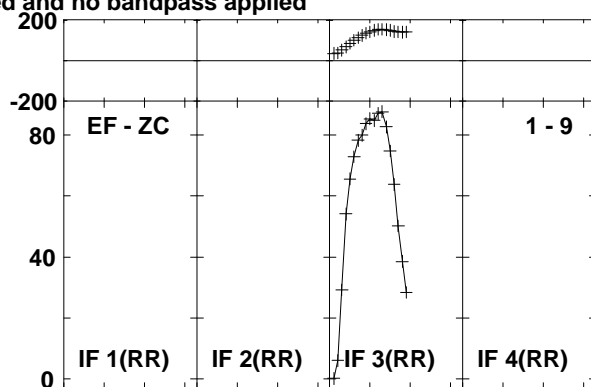
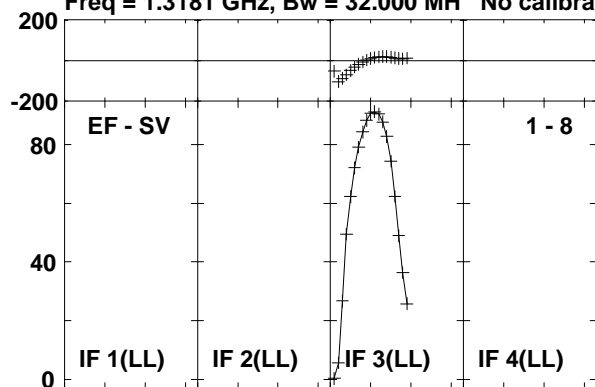

Lower frame: Milli Ampl Jy Top frame: Phas deg
 Vector averaged cross-power spectrum Baseline: EF (01) - SV (08)
 Timerange: 00/10:16:13 to 00/10:26:09

Plot file version 128 created 20-NOV-2015 13:43:58
 3C84 EO013 1.UVDATA.1
 Freq = 1.3181 GHz, Bw = 32.000 MH No calibration applied and no bandpass applied

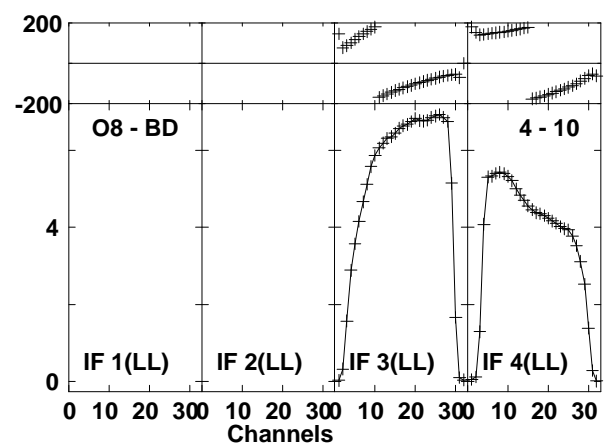
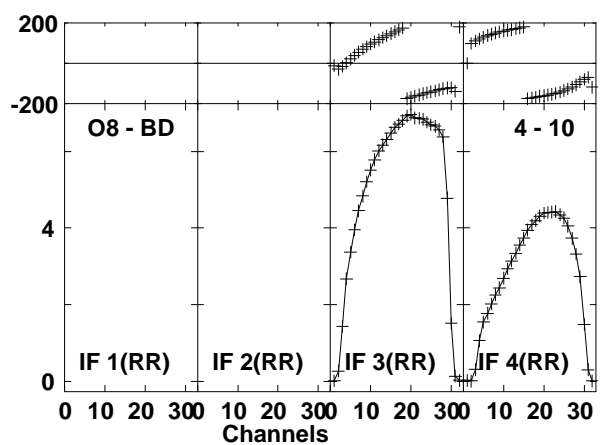
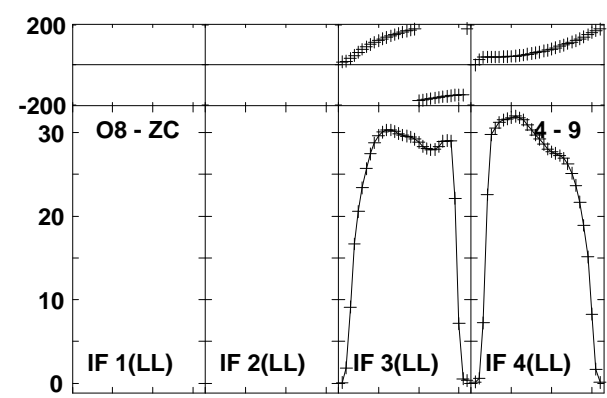
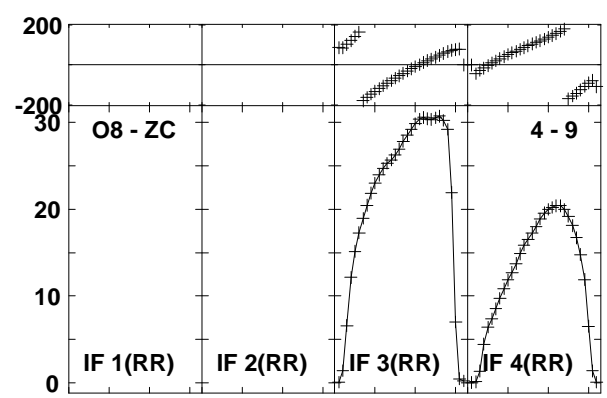
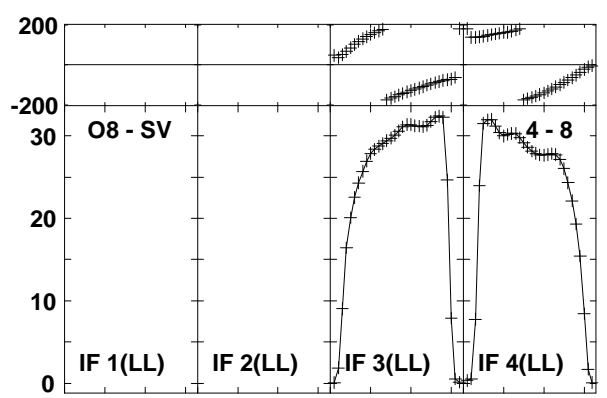
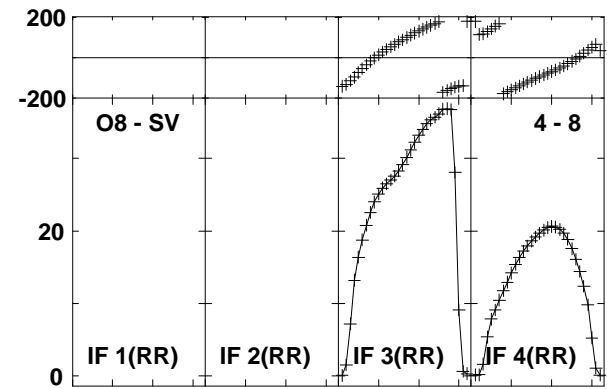
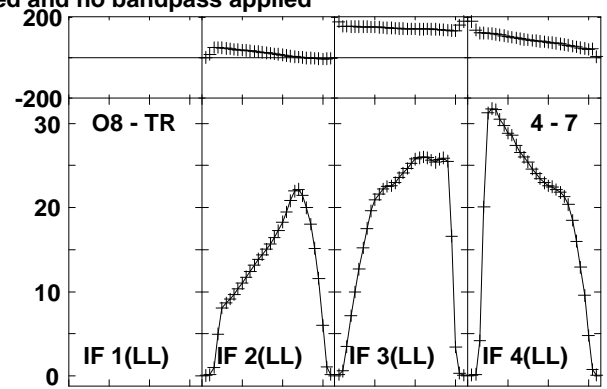
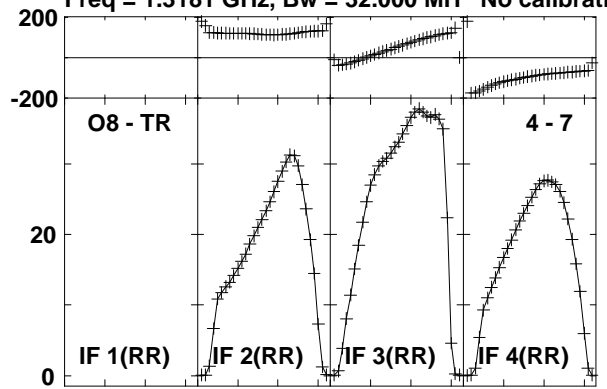

Lower frame: Milli Ampl Jy Top frame: Phas deg
 Vector averaged cross-power spectrum Baseline: O8 (04) - TR (07)
 Timerange: 00/10:16:13 to 00/10:26:09

Plot file version 129 created 20-NOV-2015 13:43:59

3C84 EO013 1.UVDATA.1

Freq = 1.3181 GHz, Bw = 32.000 MH No calibration applied and no bandpass applied

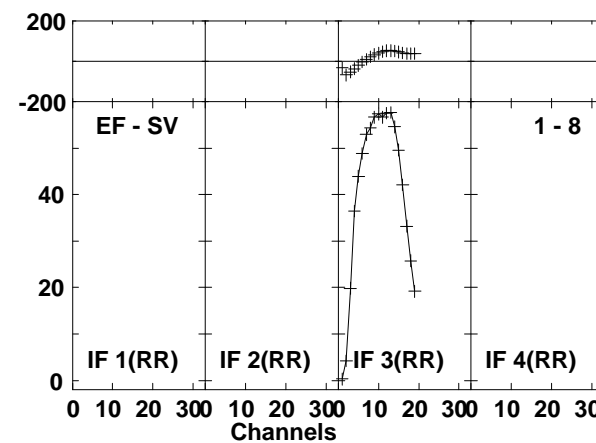
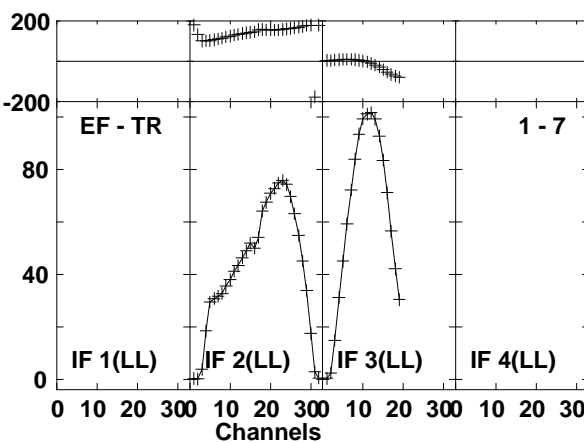
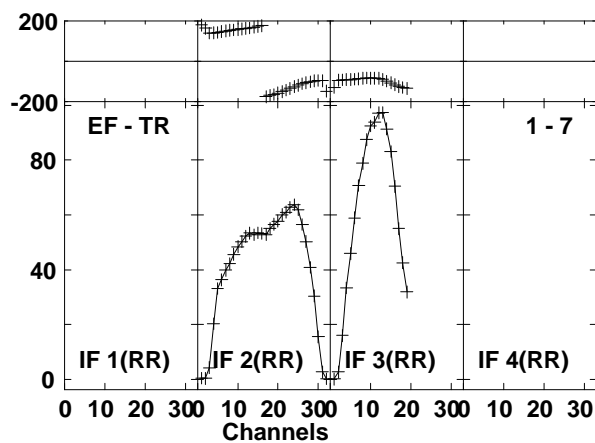
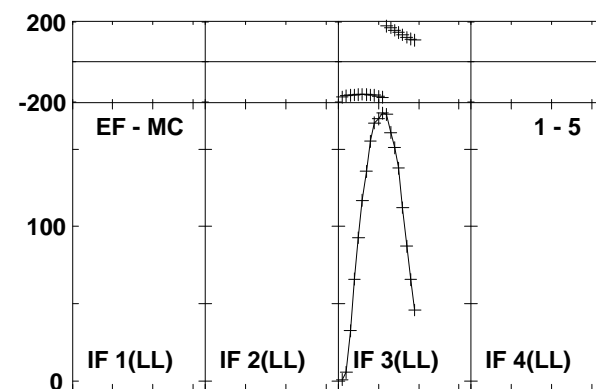
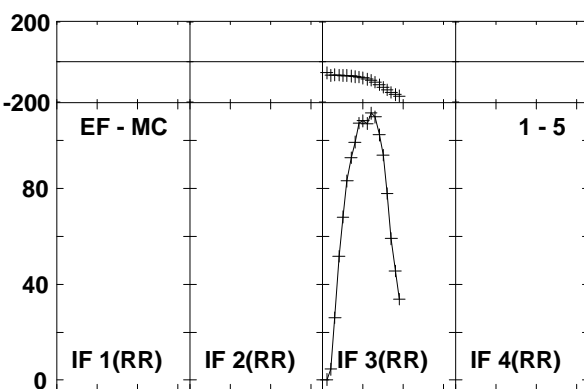
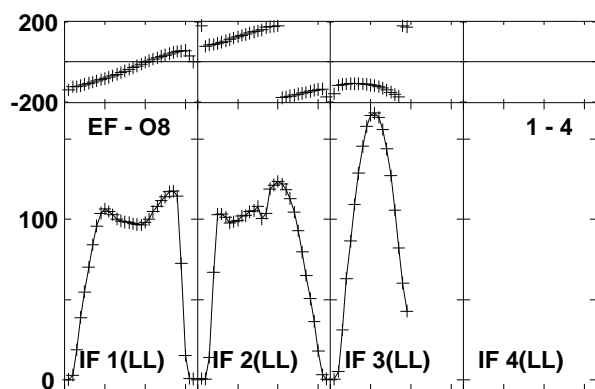
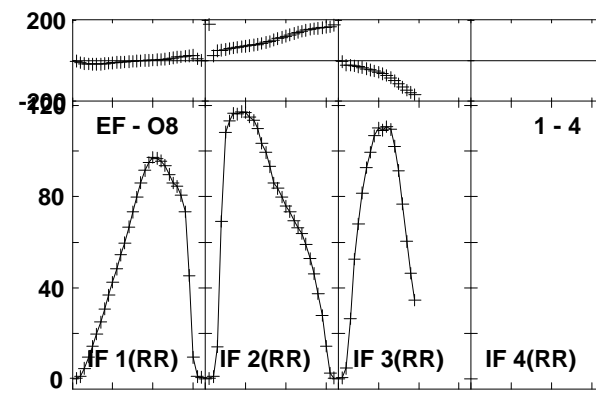
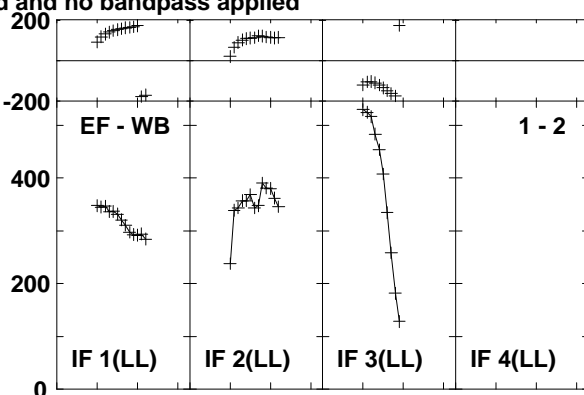
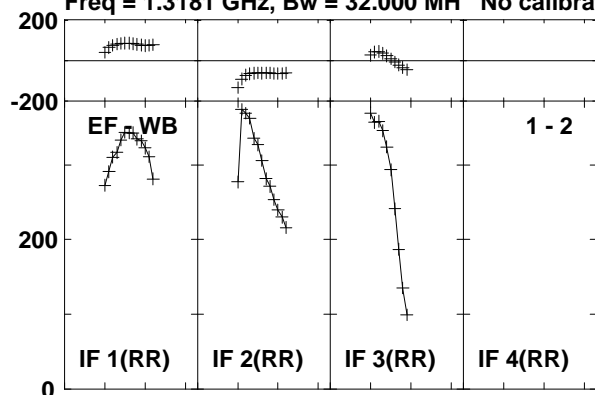

Lower frame: Milli Ampl Jy Top frame: Phas deg
Vector averaged cross-power spectrum Baseline: EF (01) - WB (02)
Timerange: 00/10:26:43 to 00/10:36:39

Plot file version 130 created 20-NOV-2015 13:43:59
 3C84 EO013 1.UVDATA.1
 Freq = 1.3181 GHz, Bw = 32.000 MH No calibration applied and no bandpass applied

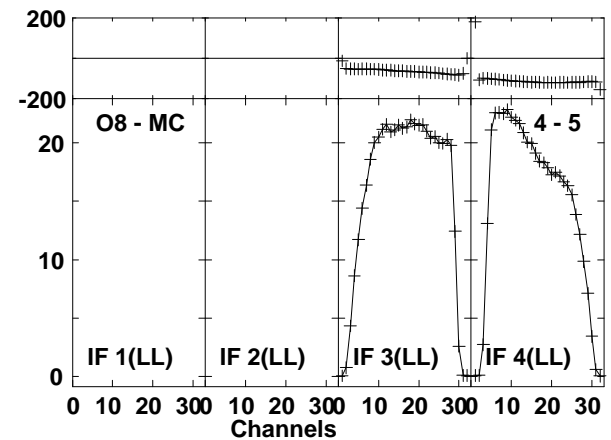
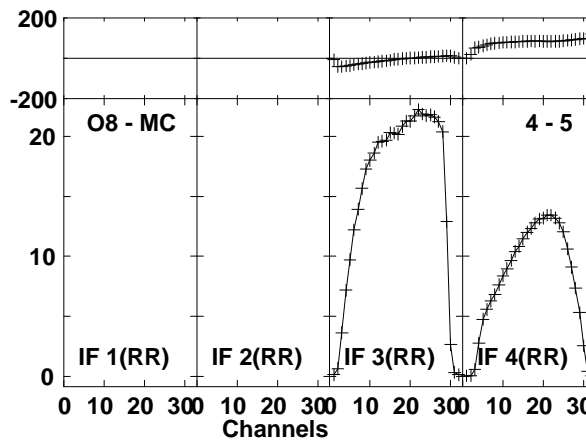
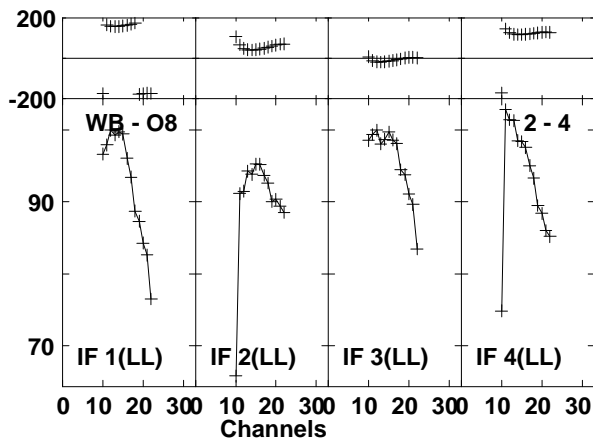
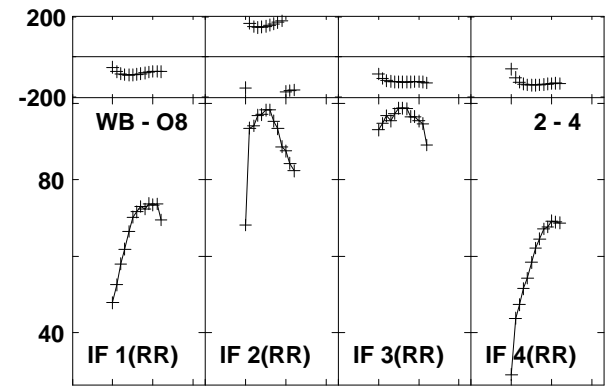
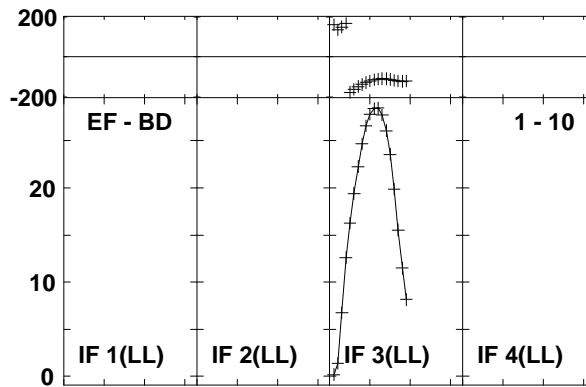
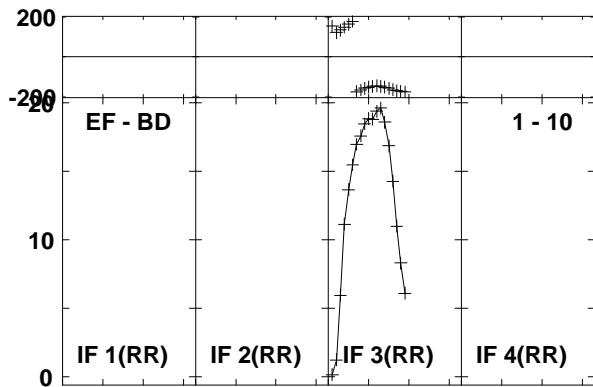
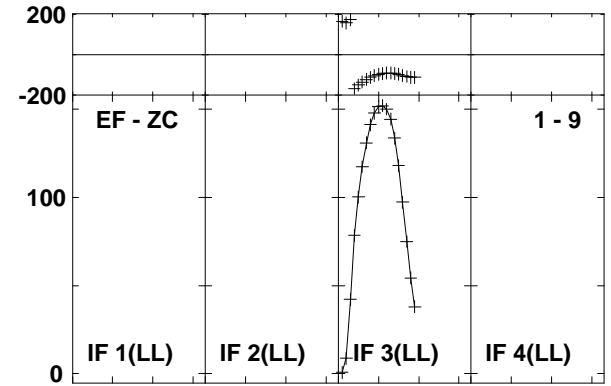
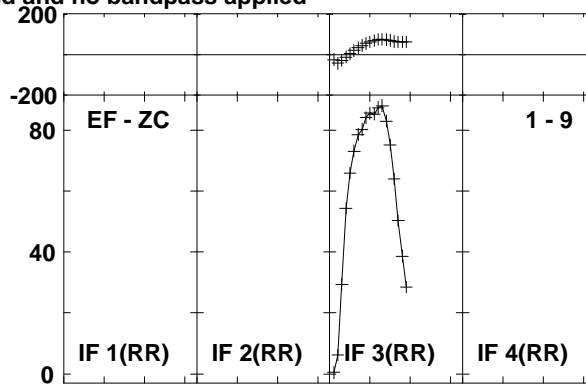
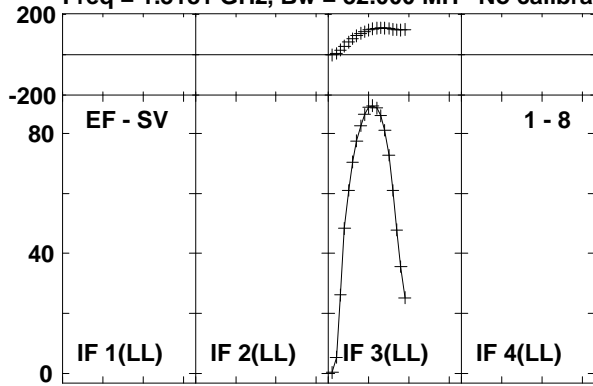

Lower frame: Milli Ampl Jy Top frame: Phas deg
 Vector averaged cross-power spectrum Baseline: EF (01) - SV (08)
 Timerange: 00/10:26:43 to 00/10:36:39

Plot file version 131 created 20-NOV-2015 13:43:59
 3C84 EO013 1.UVDATA.1
 Freq = 1.3181 GHz, Bw = 32.000 MH No calibration applied and no bandpass applied

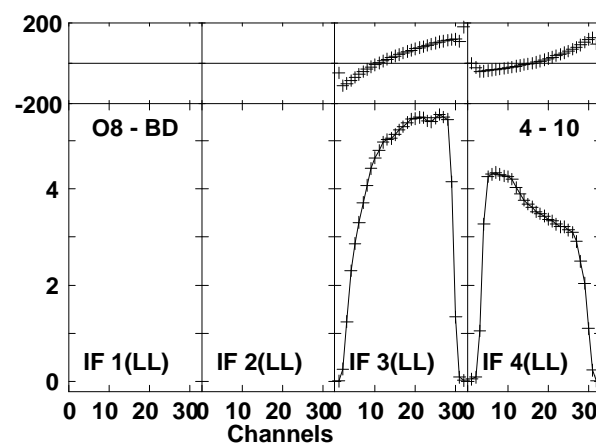
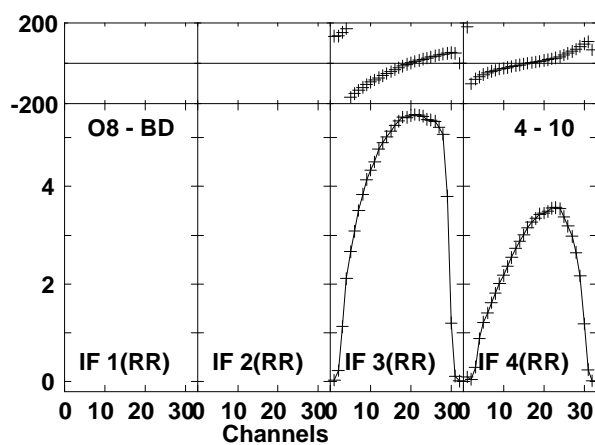
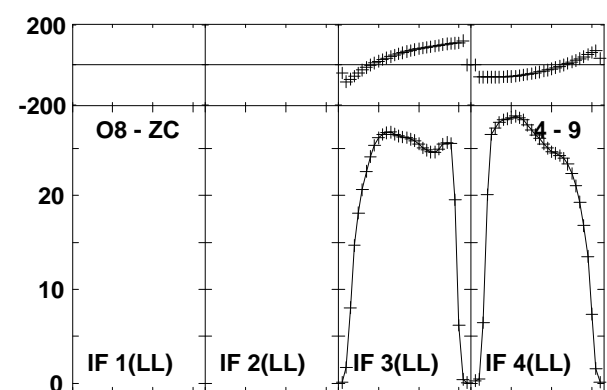
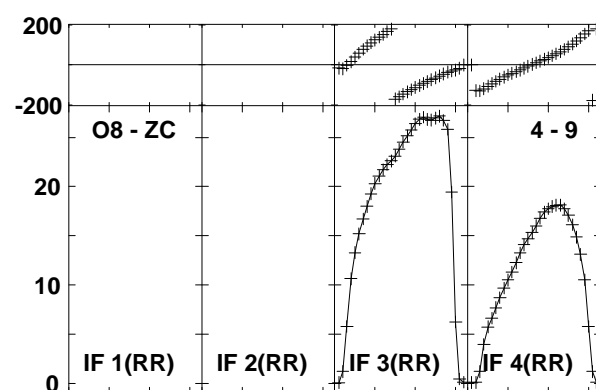
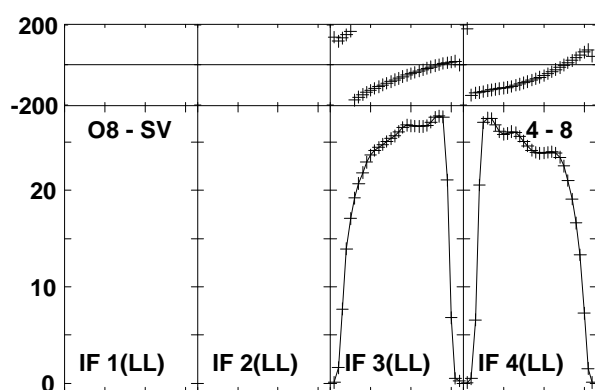
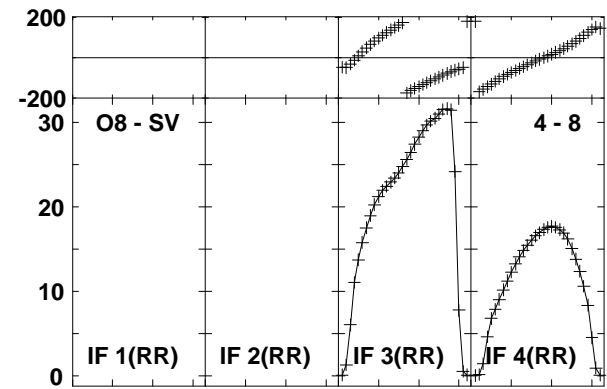
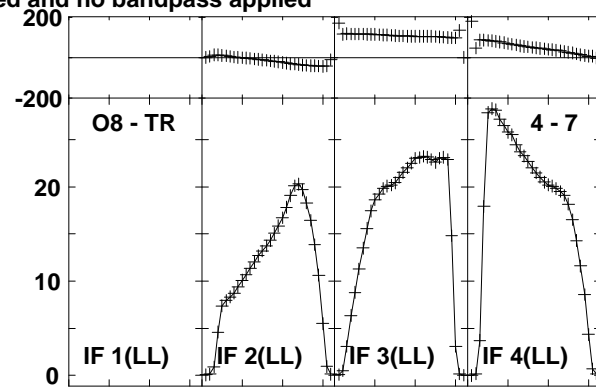
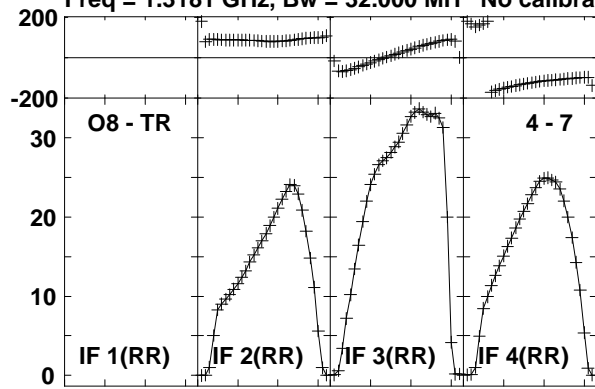

Lower frame: Milli Ampl Jy Top frame: Phas deg
 Vector averaged cross-power spectrum Baseline: O8 (04) - TR (07)
 Timerange: 00/10:26:43 to 00/10:36:39

Plot file version 132 created 20-NOV-2015 13:43:59

3C84 EO013 1.UVDATA.1

Freq = 1.3181 GHz, Bw = 32.000 MH No calibration applied and no bandpass applied

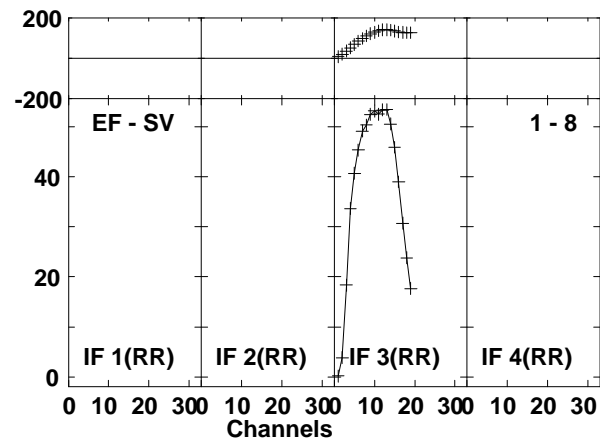
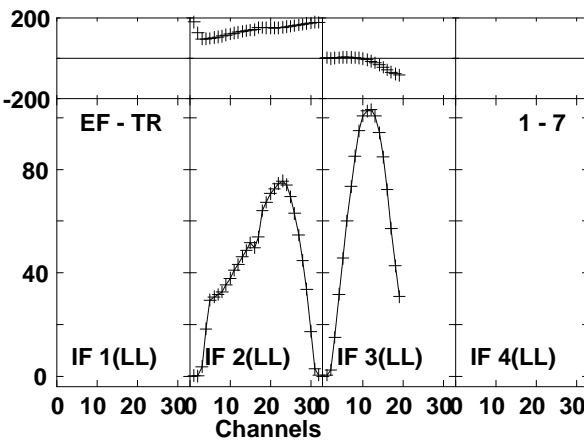
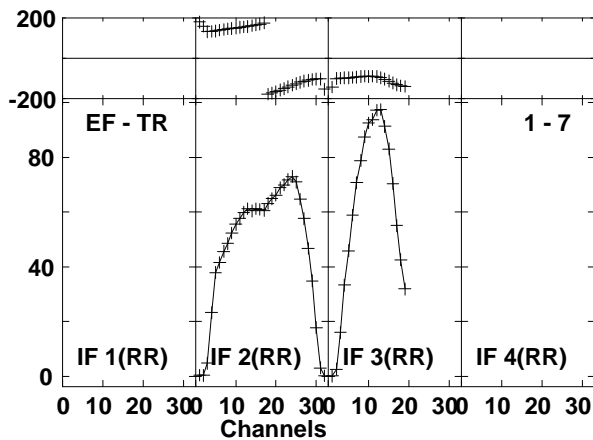
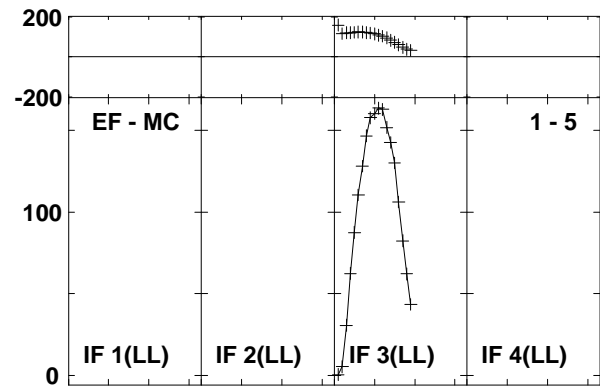
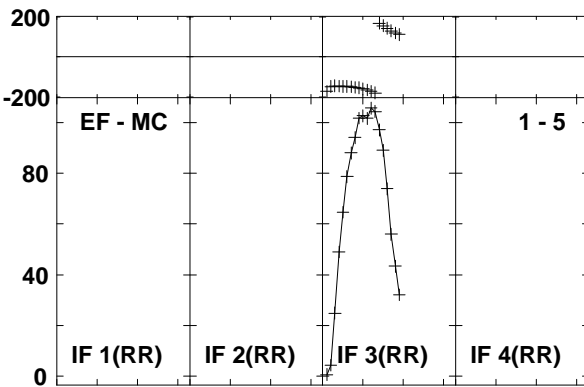
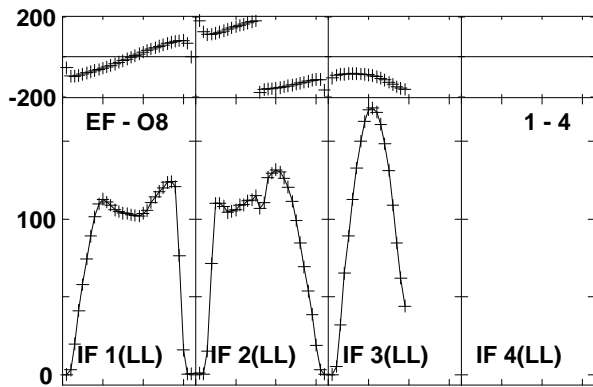
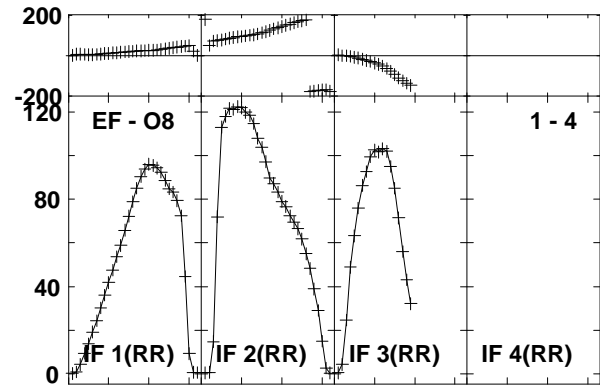
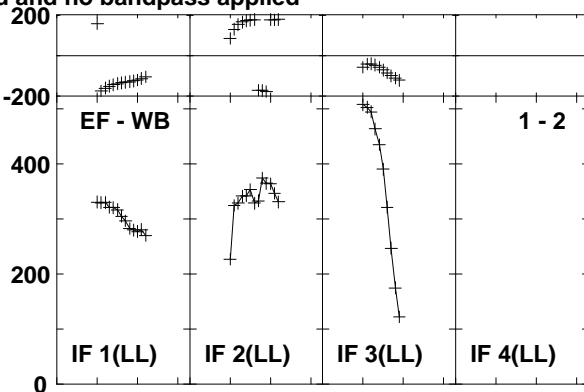
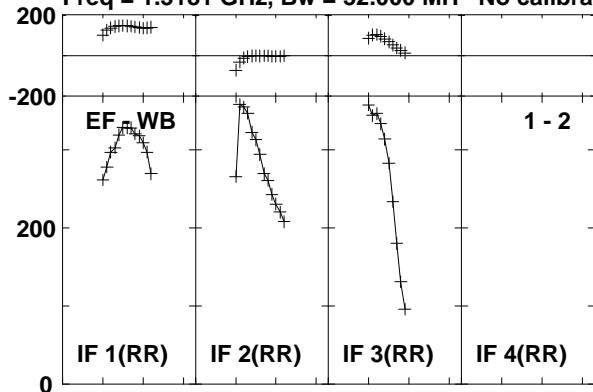

Lower frame: Milli Ampl Jy Top frame: Phas deg
Vector averaged cross-power spectrum Baseline: EF (01) - WB (02)
Timerange: 00/10:37:13 to 00/10:47:09

Plot file version 133 created 20-NOV-2015 13:43:59
 3C84 EO013 1.UVDATA.1
 Freq = 1.3181 GHz, Bw = 32.000 MH No calibration applied and no bandpass applied

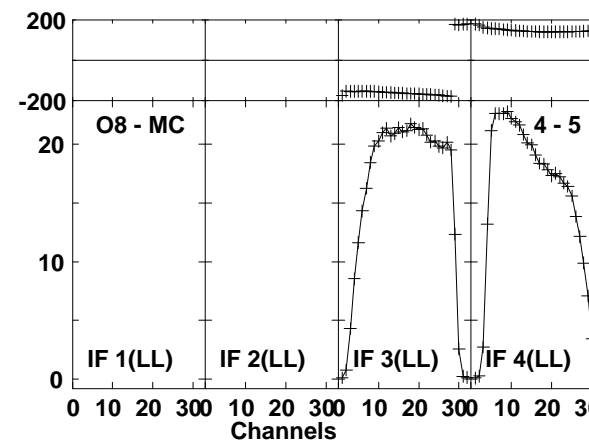
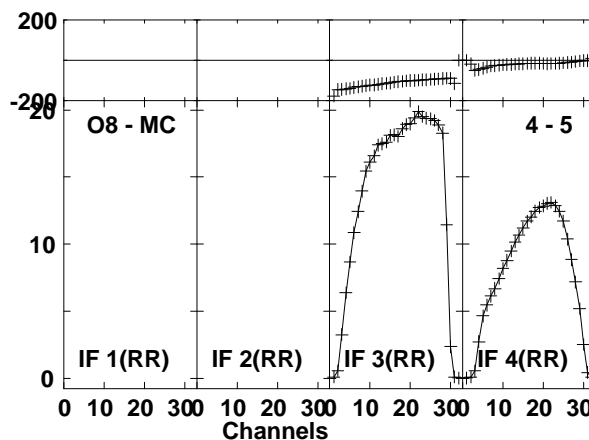
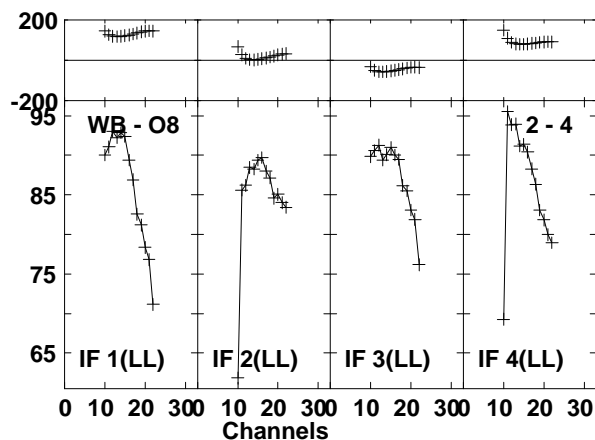
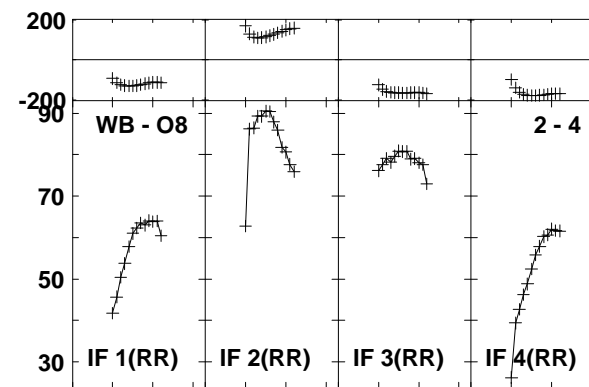
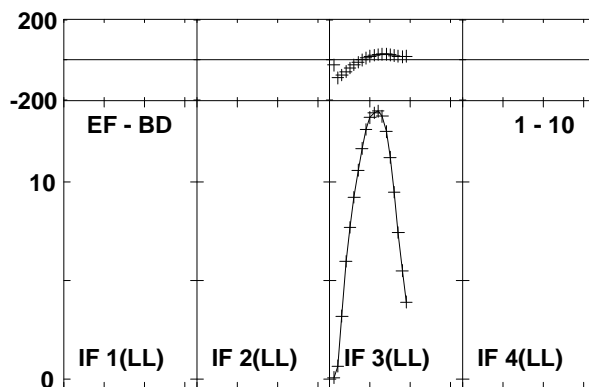
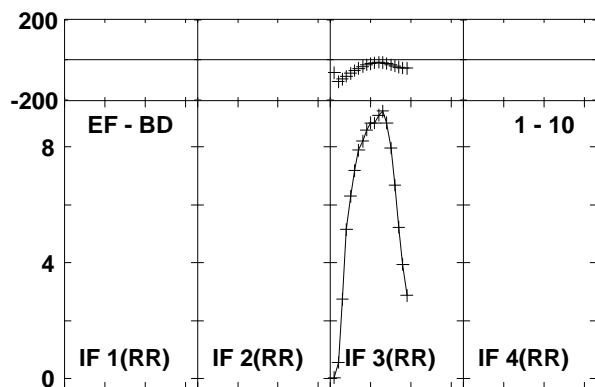
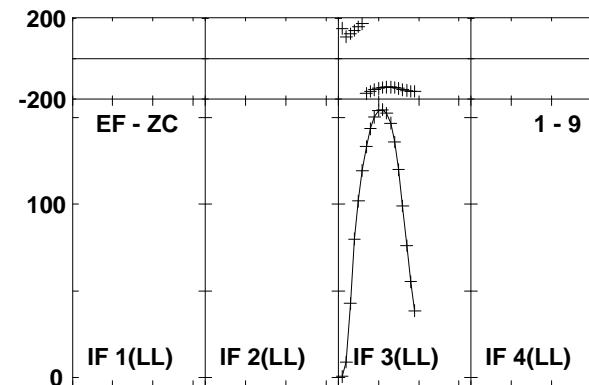
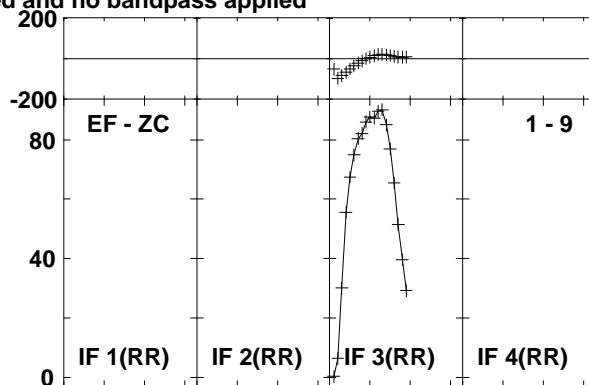
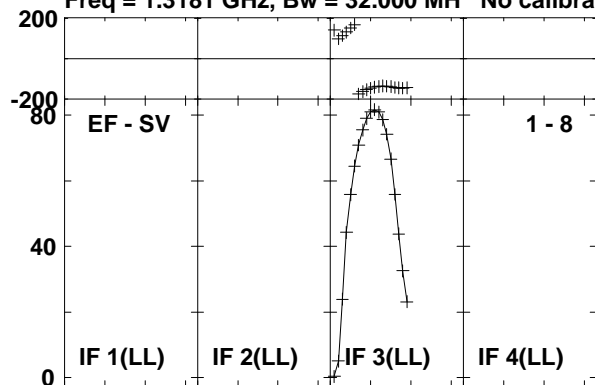

Lower frame: Milli Ampl Jy Top frame: Phas deg
 Vector averaged cross-power spectrum Baseline: EF (01) - SV (08)
 Timerange: 00/10:37:13 to 00/10:47:09

Plot file version 134 created 20-NOV-2015 13:43:59

3C84 EO013 1.UVDATA.1

Freq = 1.3181 GHz, Bw = 32.000 MH No calibration applied and no bandpass applied

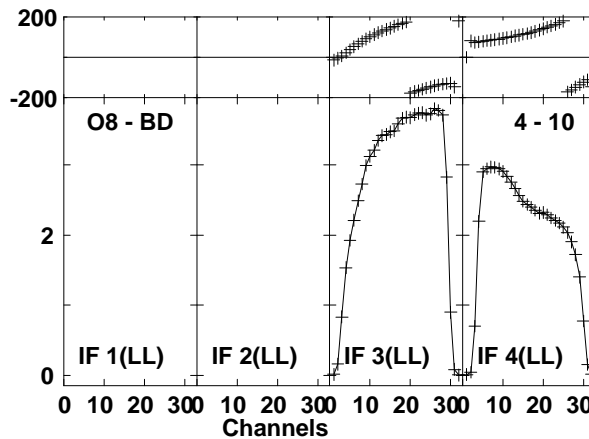
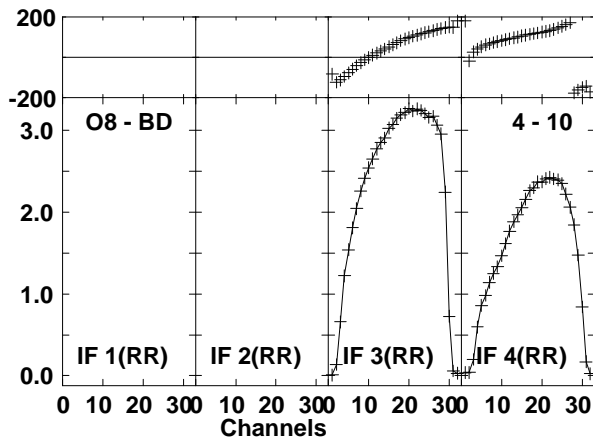
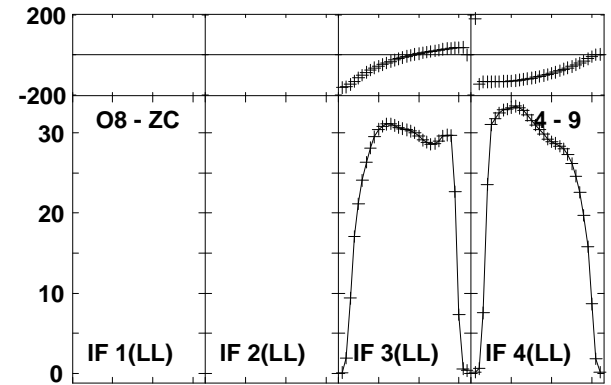
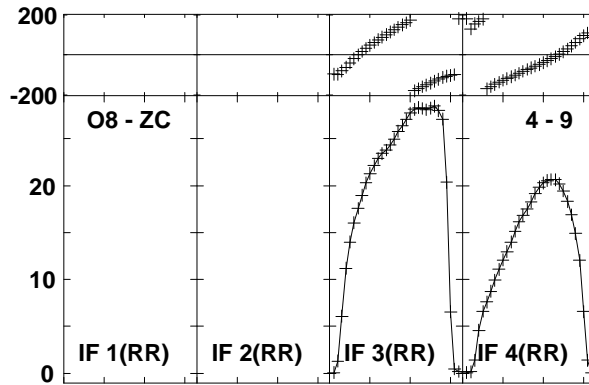
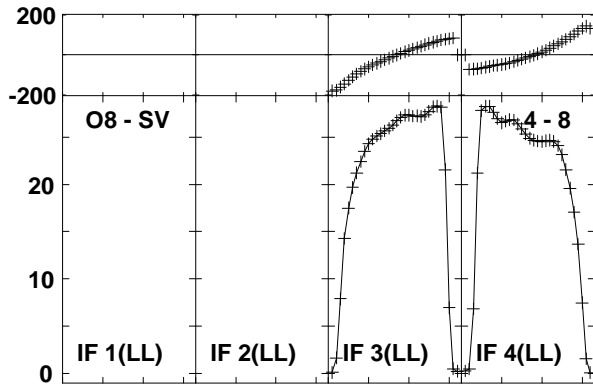
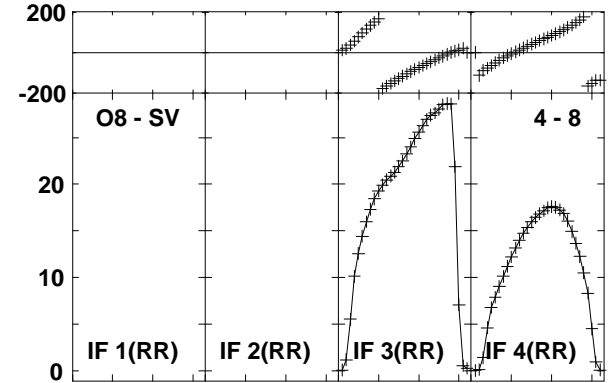
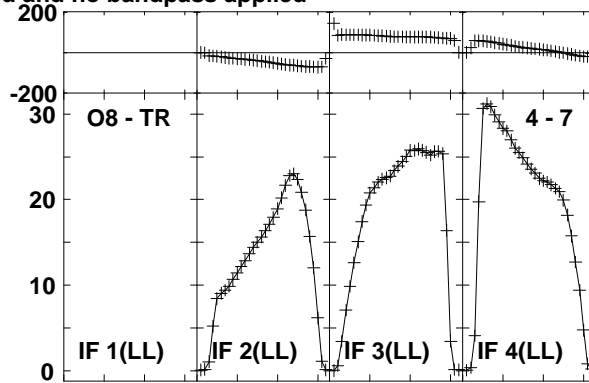
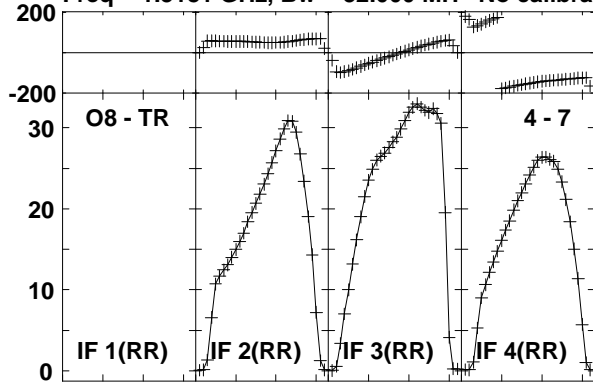

Lower frame: Milli Ampl Jy Top frame: Phas deg
Vector averaged cross-power spectrum Baseline: O8 (04) - TR (07)
Timerange: 00/10:37:13 to 00/10:47:09

Plot file version 135 created 20-NOV-2015 13:43:59

4C39.25 EO013 1.UVDATA.1

Freq = 1.3181 GHz, Bw = 32.000 MH No calibration applied and no bandpass applied

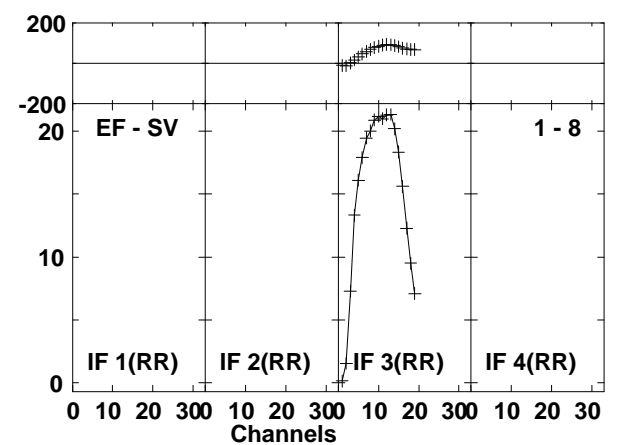
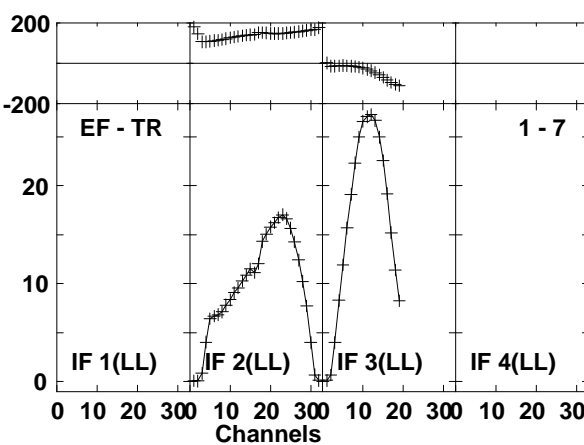
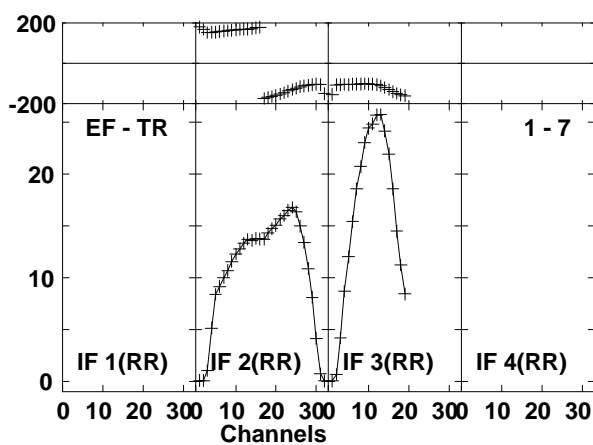
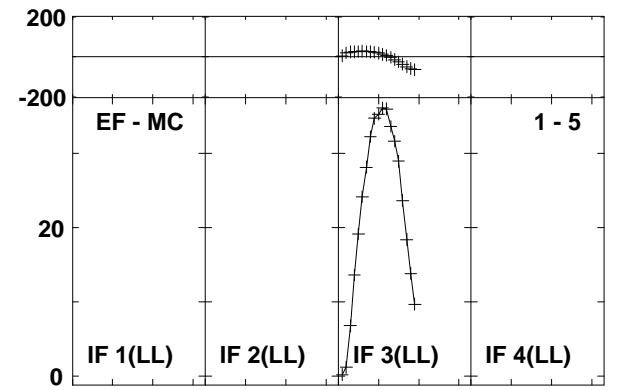
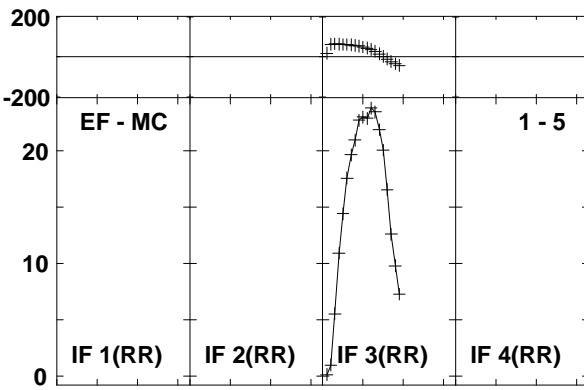
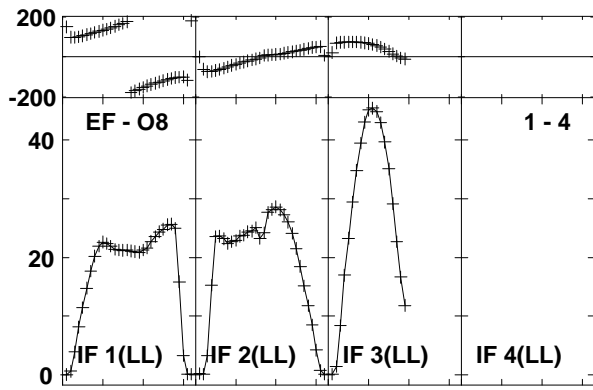
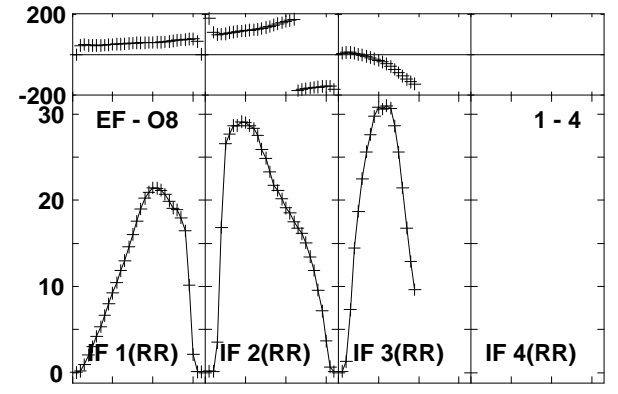
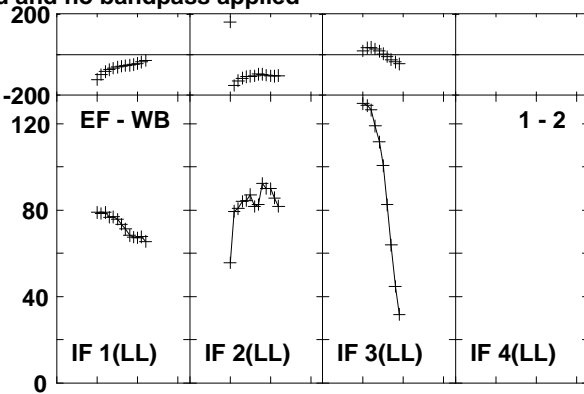
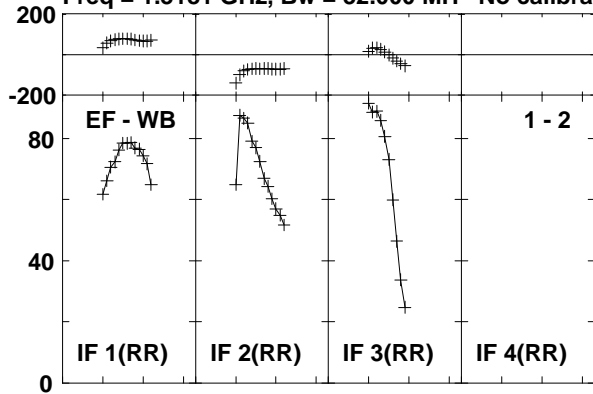

Lower frame: Milli Ampl Jy Top frame: Phas deg
Vector averaged cross-power spectrum Baseline: EF (01) - WB (02)
Timerange: 00/10:53:13 to 00/11:03:08

Plot file version 136 created 20-NOV-2015 13:43:59
 4C39.25 EO013 1.UVDATA.1
 Freq = 1.3181 GHz, Bw = 32.000 MH No calibration applied and no bandpass applied

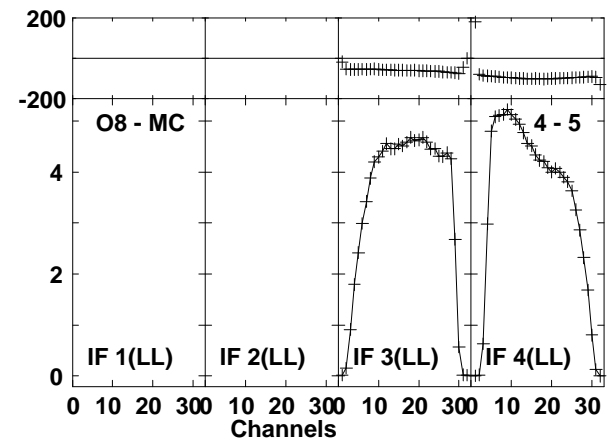
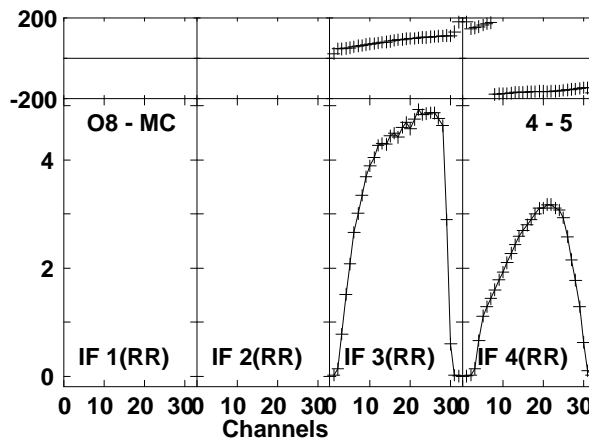
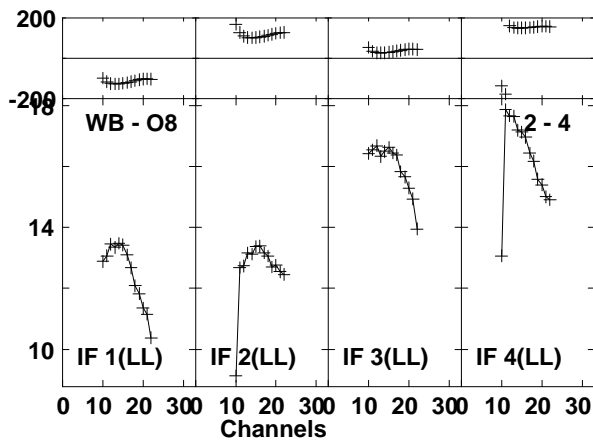
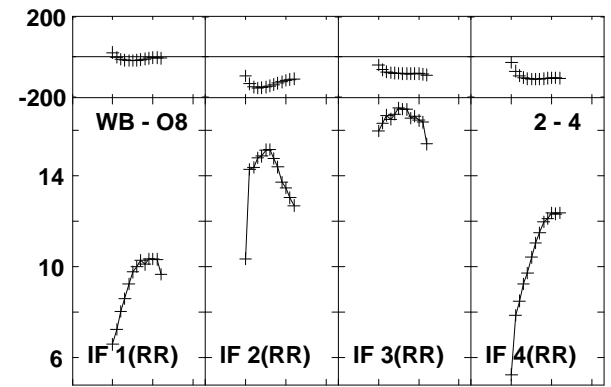
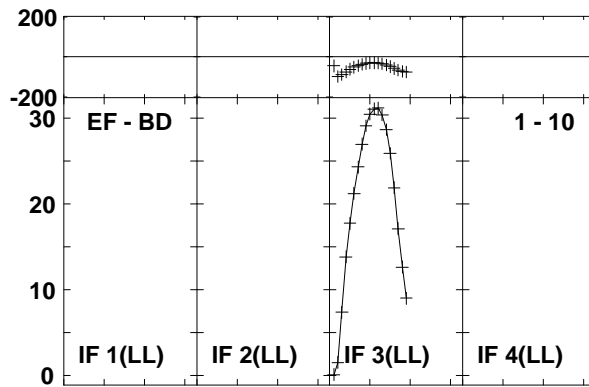
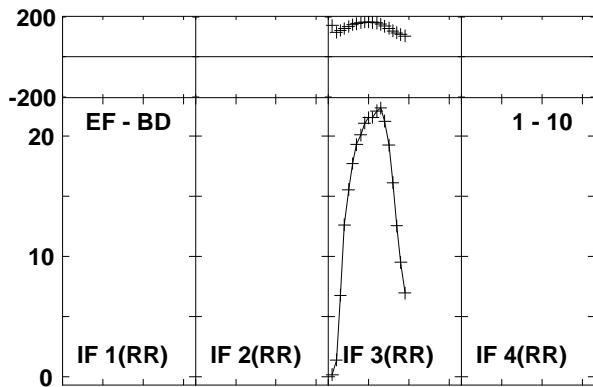
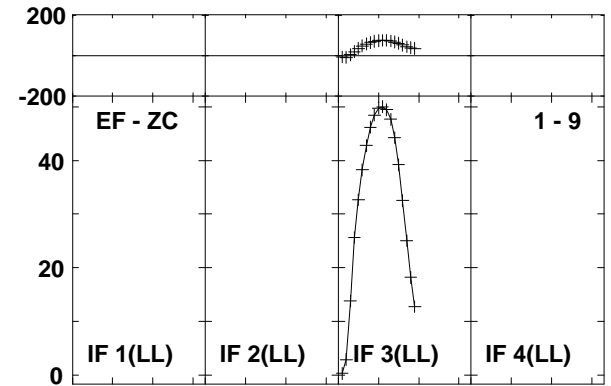
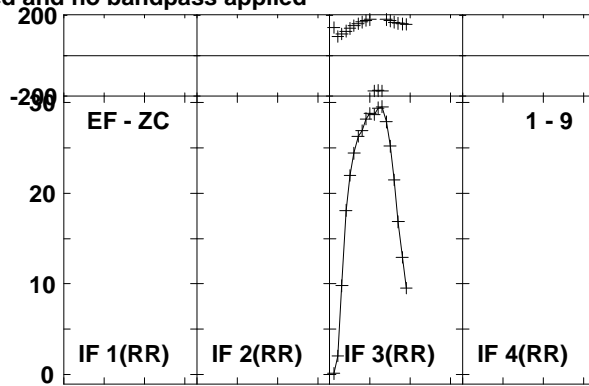
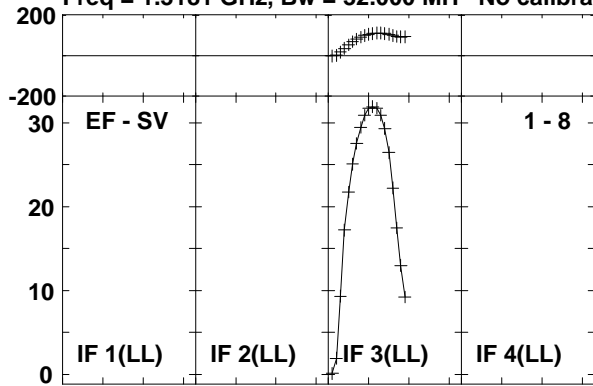

Lower frame: Milli Ampl Jy Top frame: Phas deg
 Vector averaged cross-power spectrum Baseline: EF (01) - SV (08)
 Timerange: 00/10:53:13 to 00/11:03:08

Plot file version 137 created 20-NOV-2015 13:43:59
 4C39.25 EO013 1.UVDATA.1

Freq = 1.3181 GHz, Bw = 32.000 MH No calibration applied and no bandpass applied

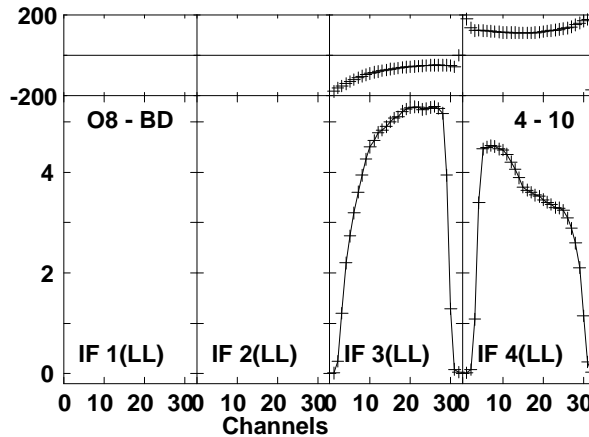
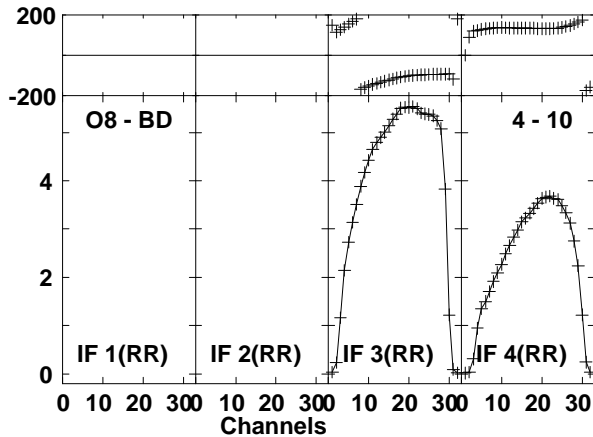
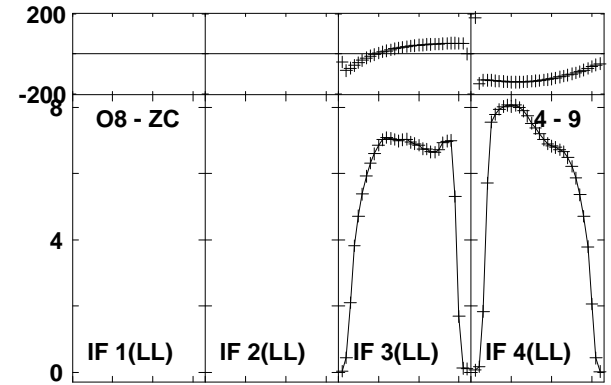
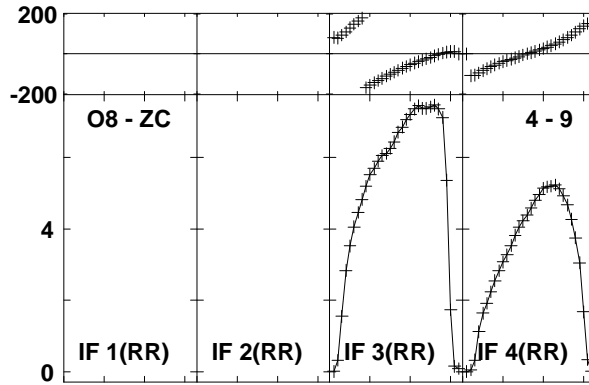
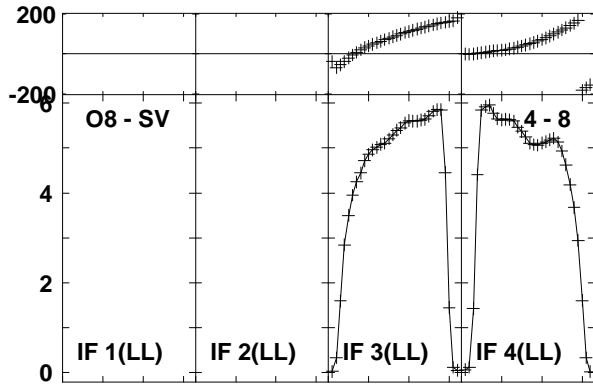
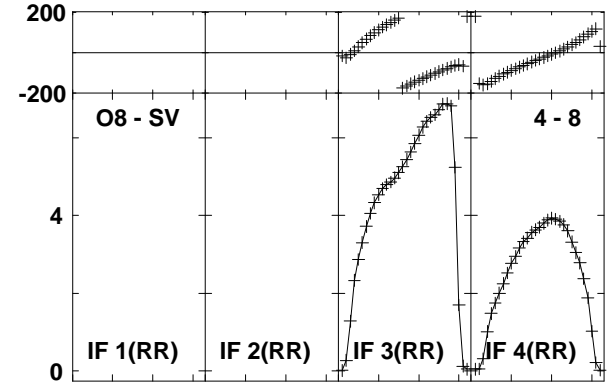
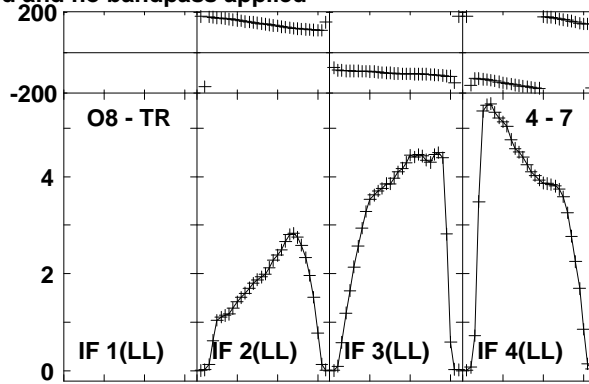
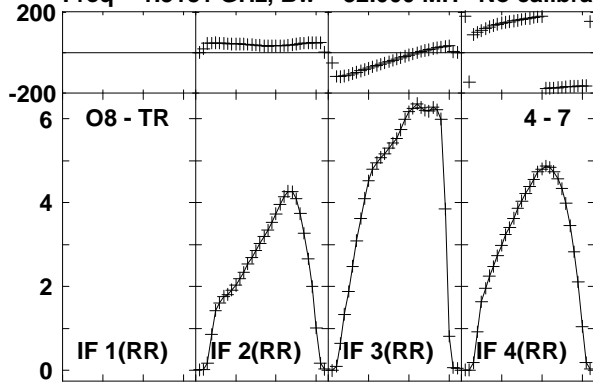

Lower frame: Milli Ampl Jy Top frame: Phas deg
 Vector averaged cross-power spectrum Baseline: O8 (04) - TR (07)
 Timerange: 00/10:53:13 to 00/11:03:08

Plot file version 138 created 20-NOV-2015 13:43:59

4C39.25 EO013 1.UVDATA.1

Freq = 1.3181 GHz, Bw = 32.000 MH No calibration applied and no bandpass applied

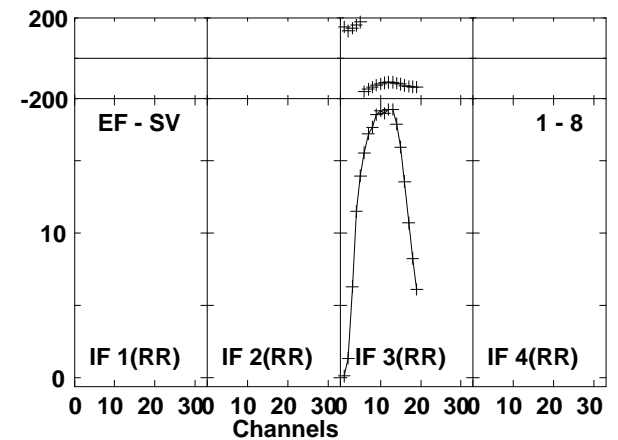
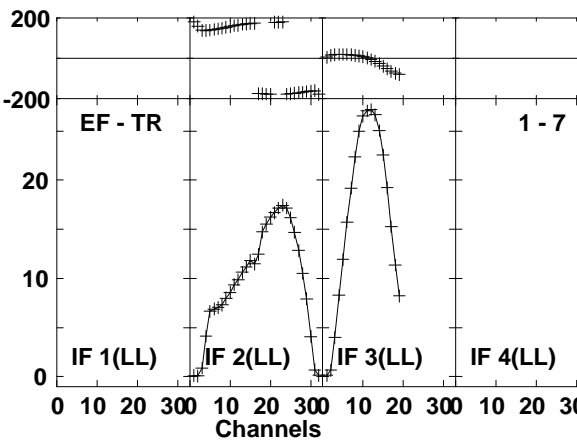
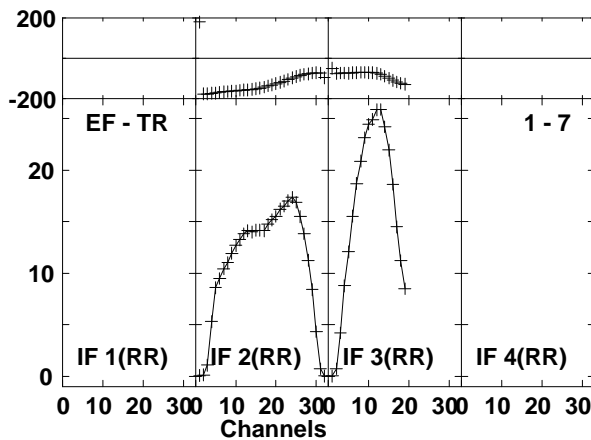
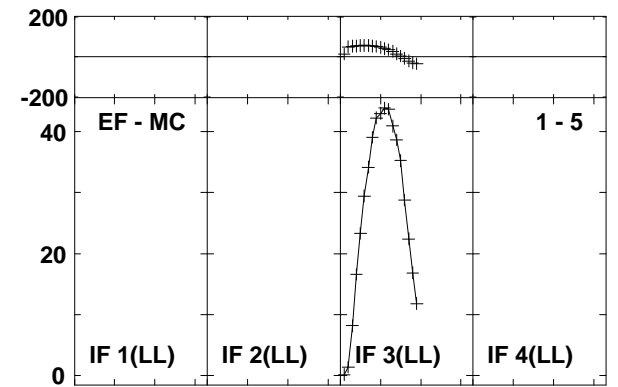
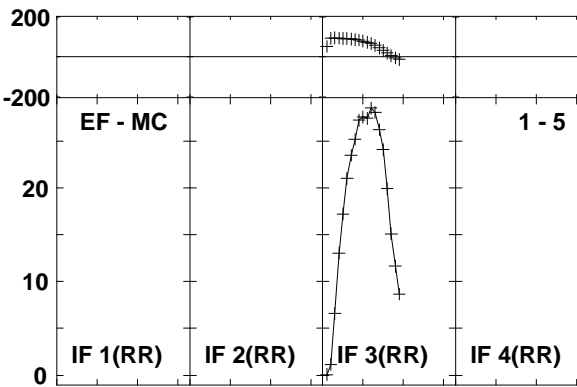
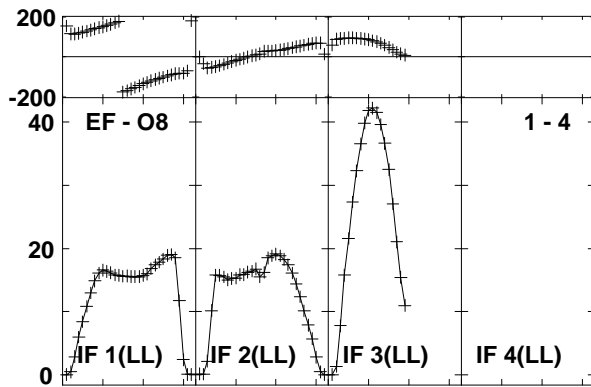
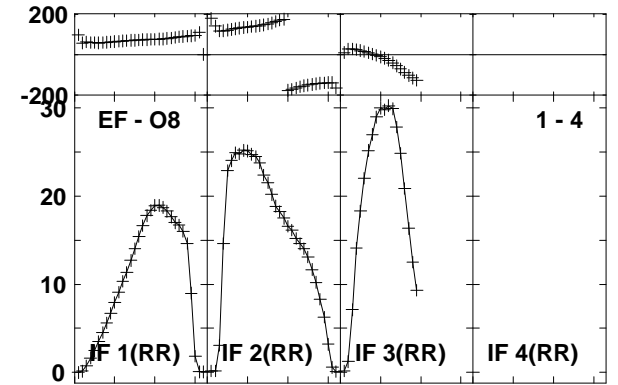
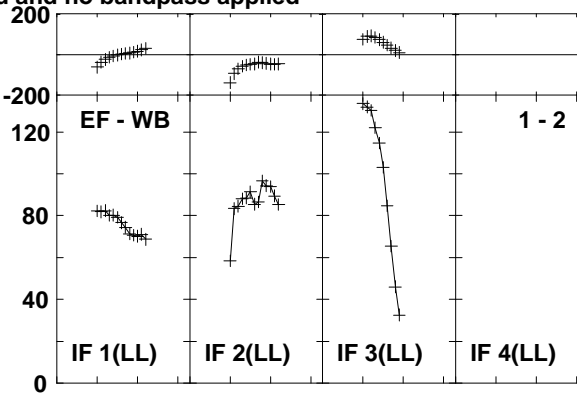
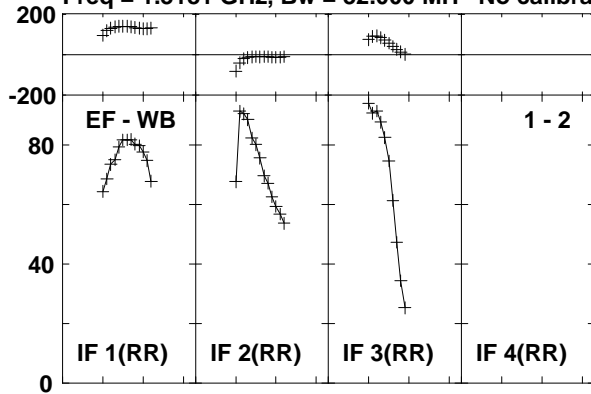

Lower frame: Milli Ampl Jy Top frame: Phas deg
Vector averaged cross-power spectrum Baseline: EF (01) - WB (02)
Timerange: 00/11:03:43 to 00/11:08:39

Plot file version 139 created 20-NOV-2015 13:43:59
 4C39.25 EO013 1.UVDATA.1
 Freq = 1.3181 GHz, Bw = 32.000 MH No calibration applied and no bandpass applied

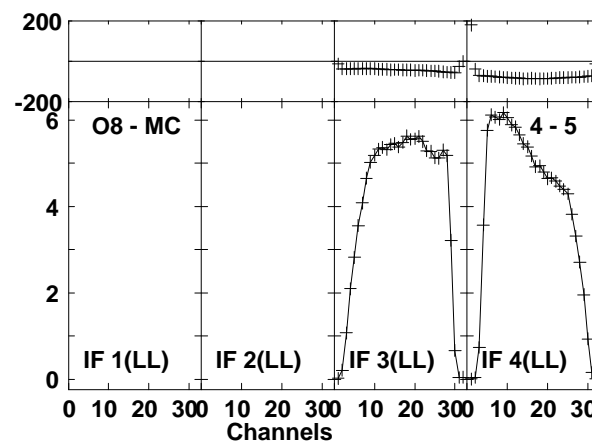
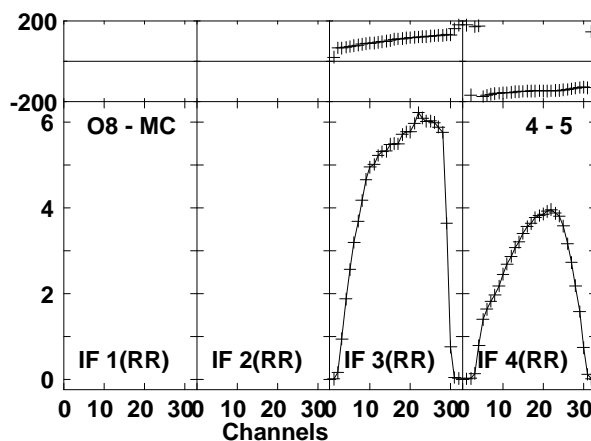
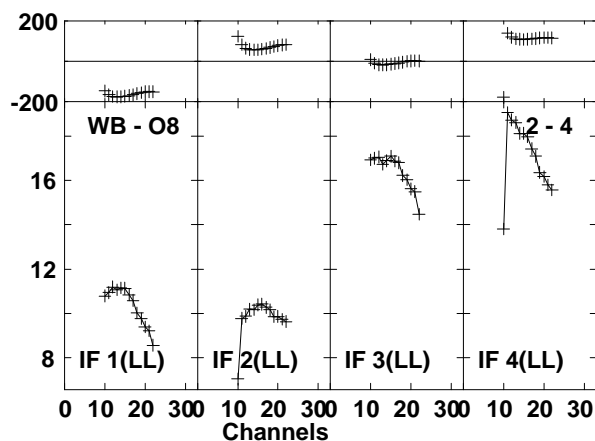
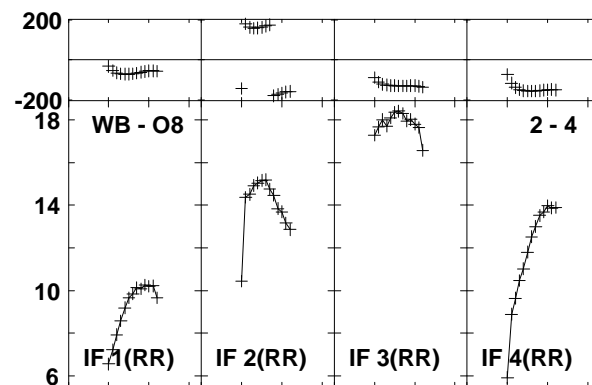
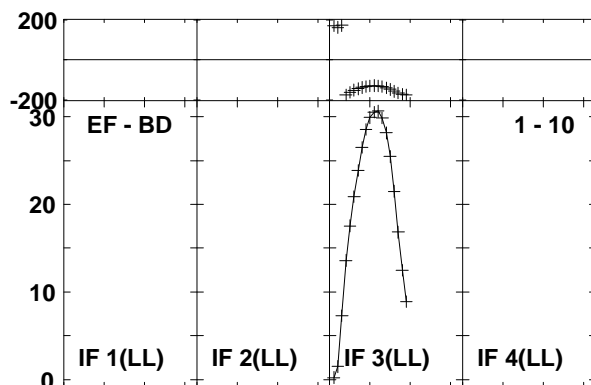
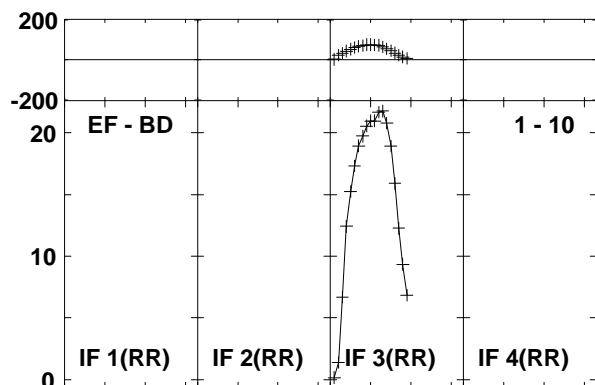
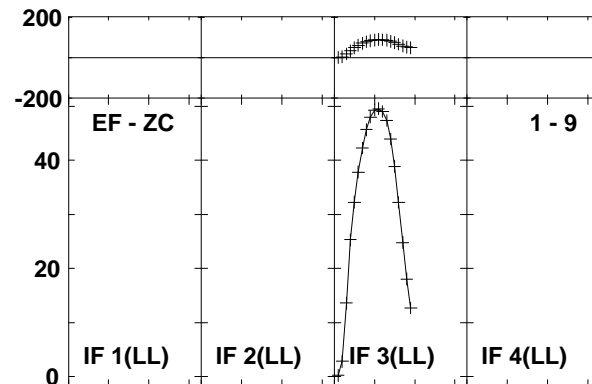
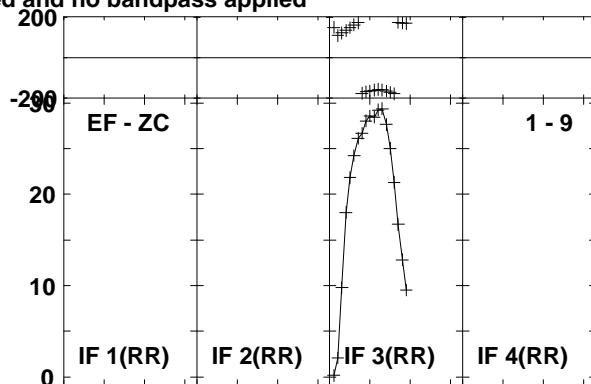
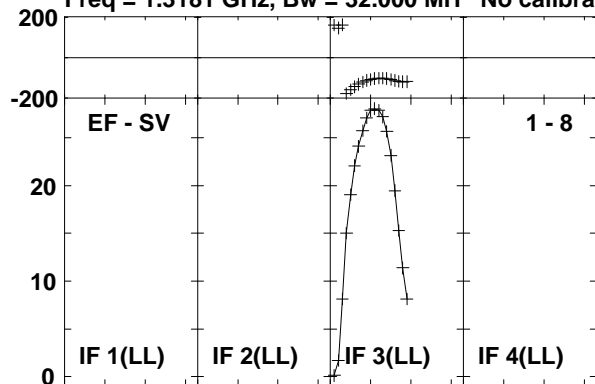

Lower frame: Milli Ampl Jy Top frame: Phas deg
 Vector averaged cross-power spectrum Baseline: EF (01) - SV (08)
 Timerange: 00/11:03:43 to 00/11:08:39

Plot file version 140 created 20-NOV-2015 13:43:59

4C39.25 EO013 1.UVDATA.1

Freq = 1.3181 GHz, Bw = 32.000 MH No calibration applied and no bandpass applied

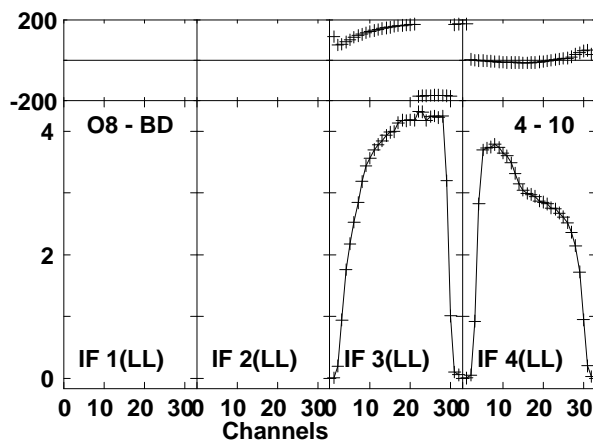
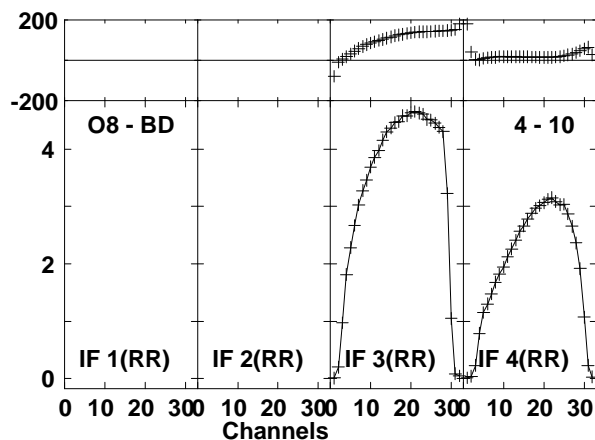
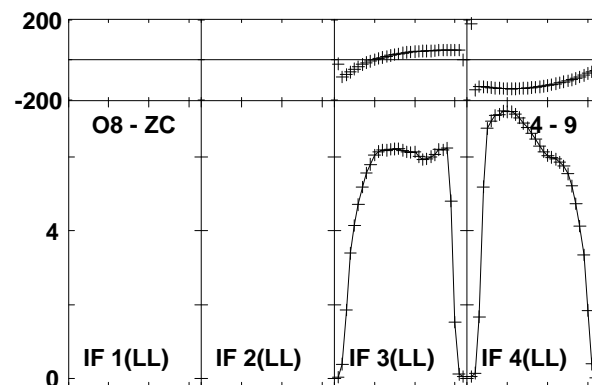
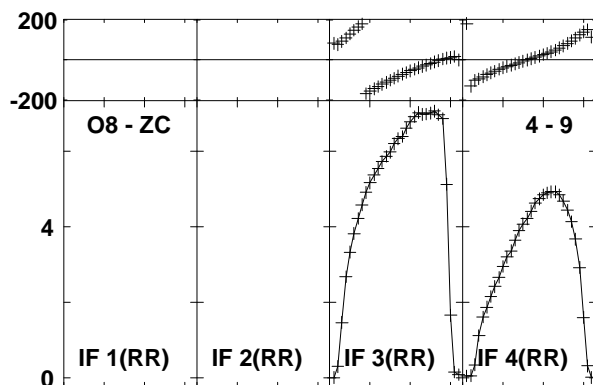
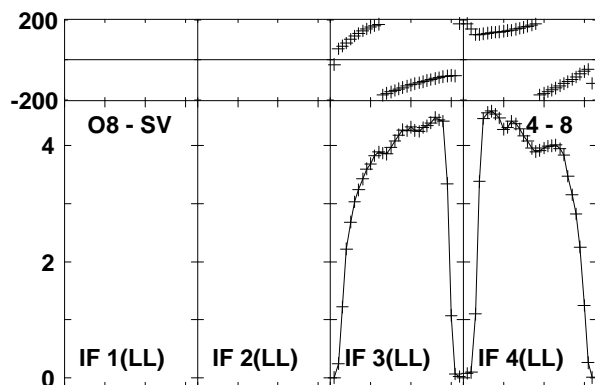
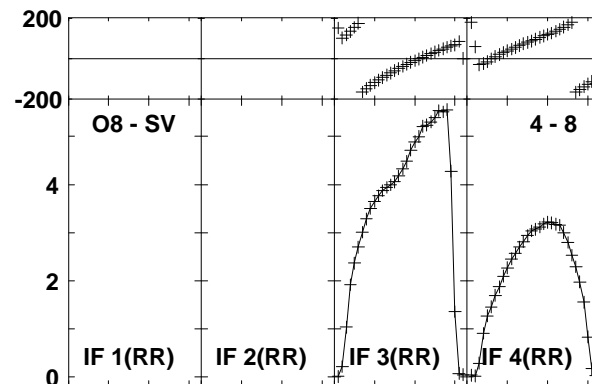
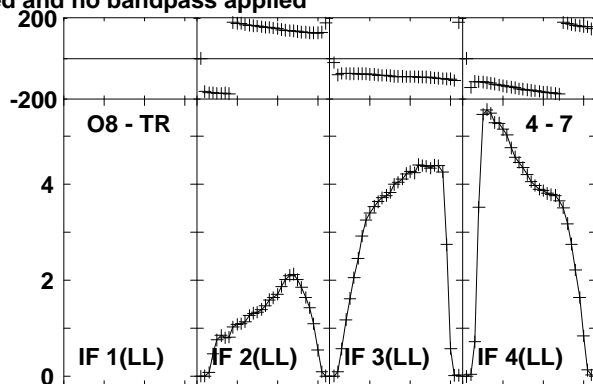
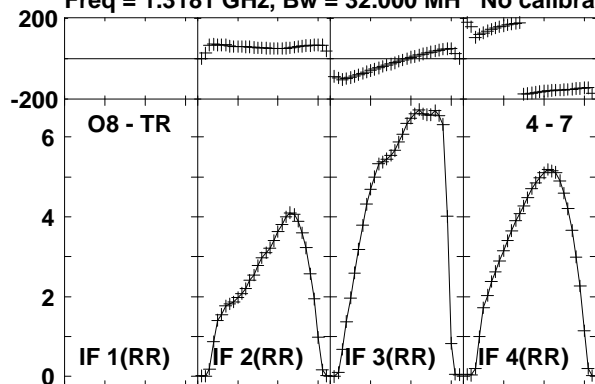

Lower frame: Milli Ampl Jy Top frame: Phas deg
Vector averaged cross-power spectrum Baseline: O8 (04) - TR (07)
Timerange: 00/11:03:43 to 00/11:08:39

Plot file version 141 created 20-NOV-2015 13:43:59
 3C84 EO013 1.UVDATA.1
 Freq = 1.3181 GHz, Bw = 32.000 MH No calibration applied and no bandpass applied

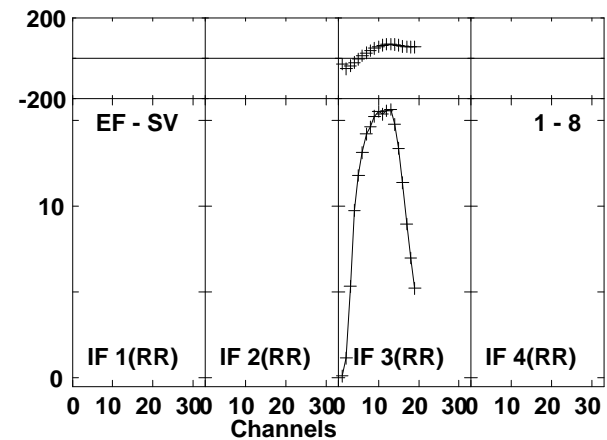
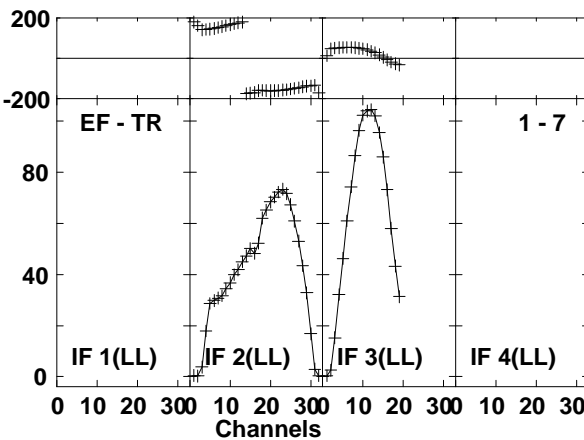
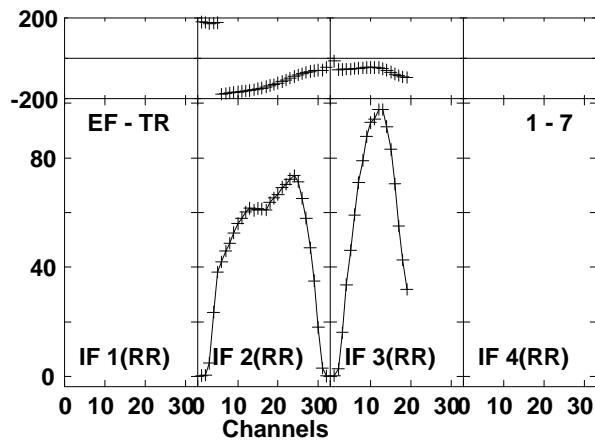
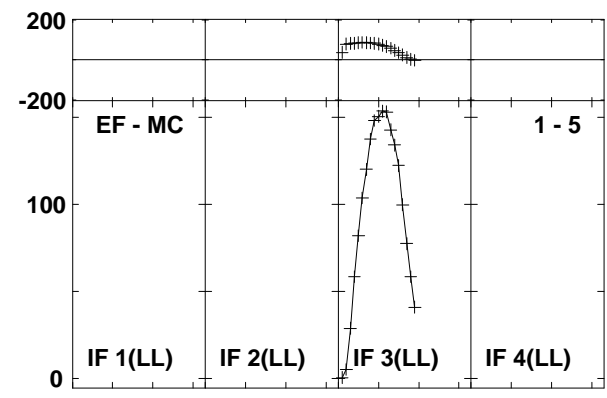
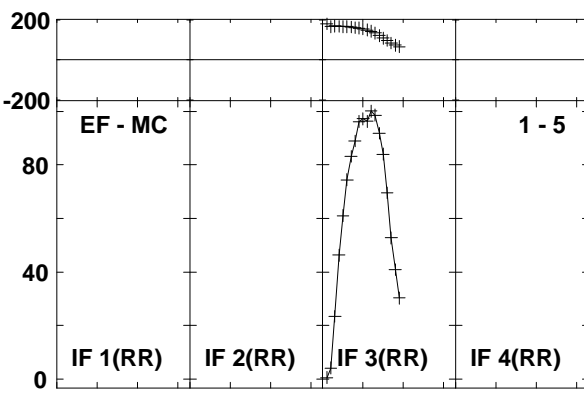
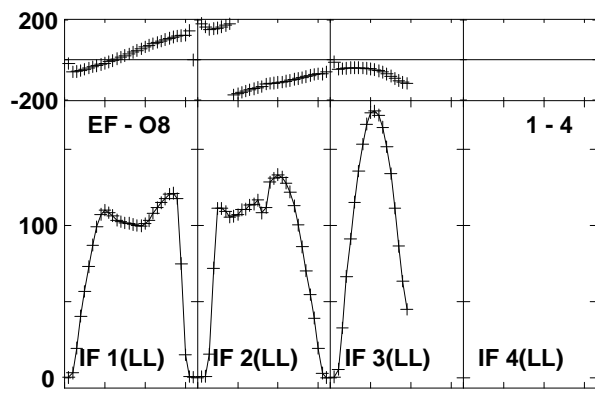
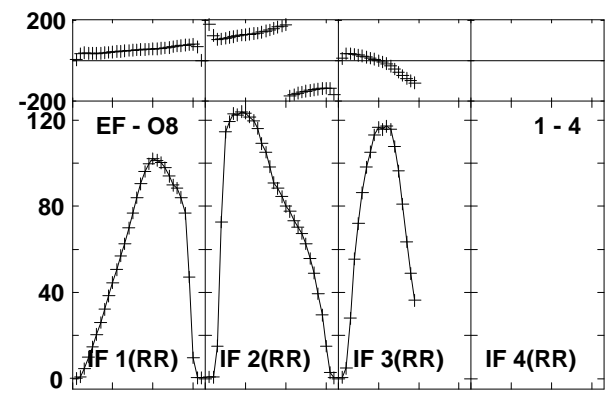
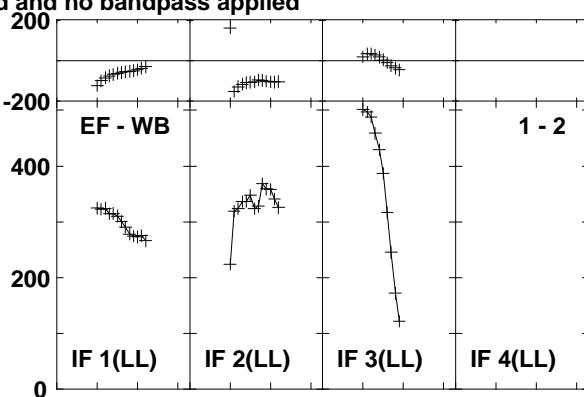
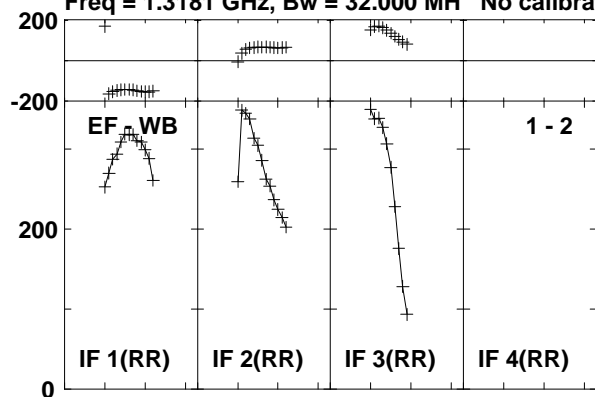

Lower frame: Milli Ampl Jy Top frame: Phas deg
 Vector averaged cross-power spectrum Baseline: EF (01) - WB (02)
 Timerange: 00/11:14:48 to 00/11:24:43

Plot file version 142 created 20-NOV-2015 13:44:00
 3C84 EO013 1.UVDATA.1
 Freq = 1.3181 GHz, Bw = 32.000 MH No calibration applied and no bandpass applied

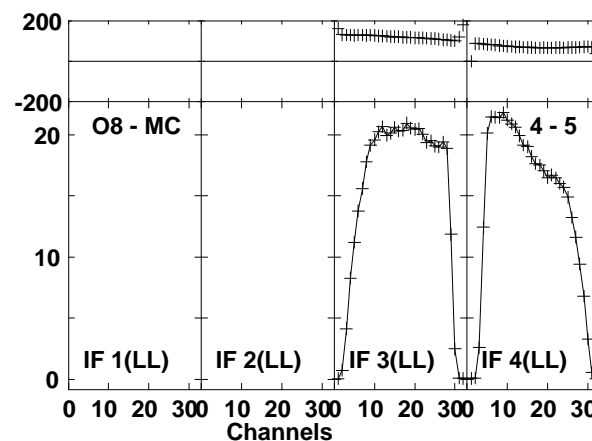
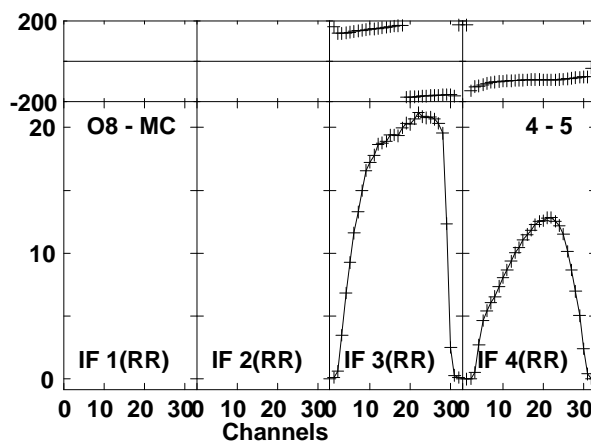
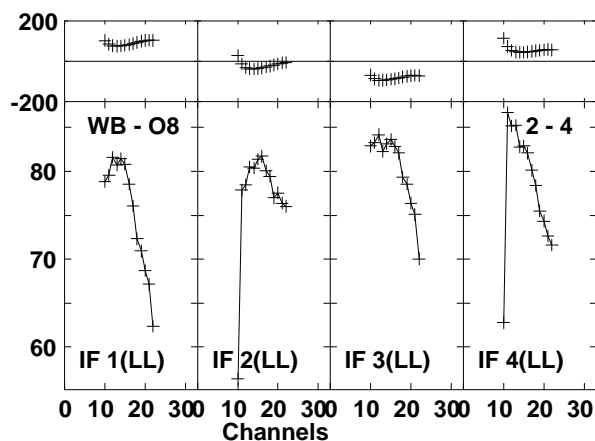
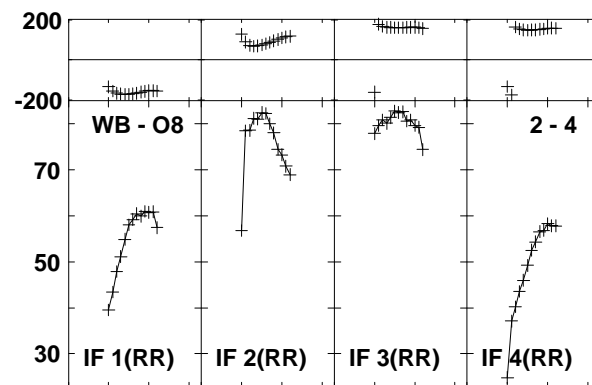
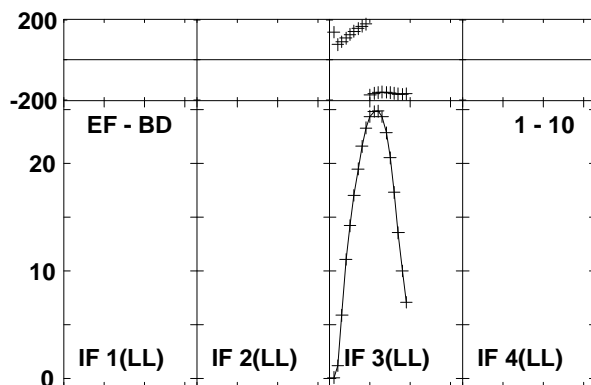
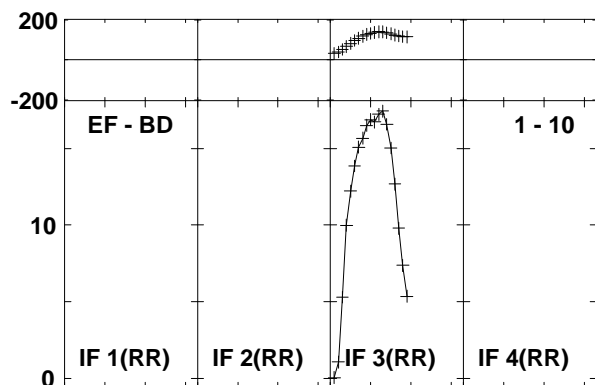
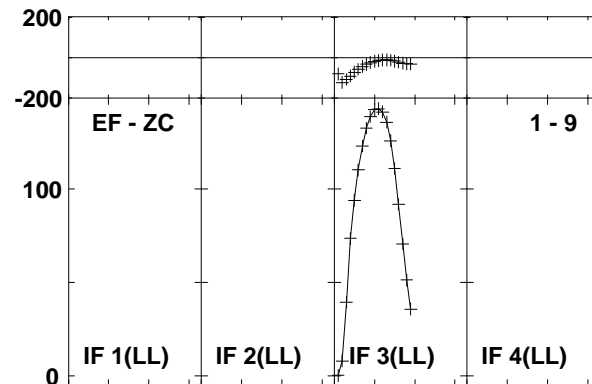
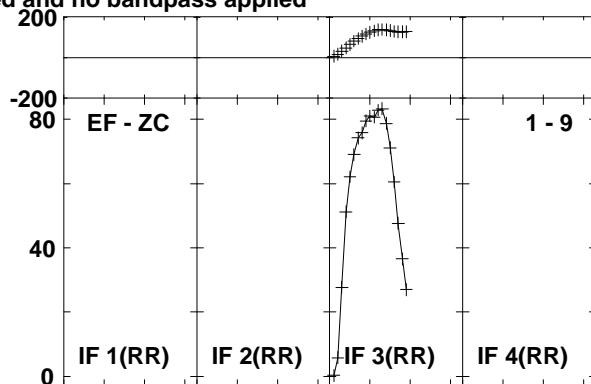
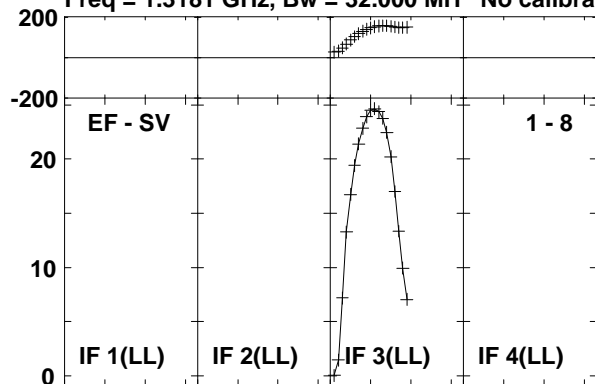

Lower frame: Milli Ampl Jy Top frame: Phas deg
 Vector averaged cross-power spectrum Baseline: EF (01) - SV (08)
 Timerange: 00/11:14:48 to 00/11:24:43

Plot file version 143 created 20-NOV-2015 13:44:00

3C84 EO013 1.UVDATA.1

Freq = 1.3181 GHz, Bw = 32.000 MH No calibration applied and no bandpass applied

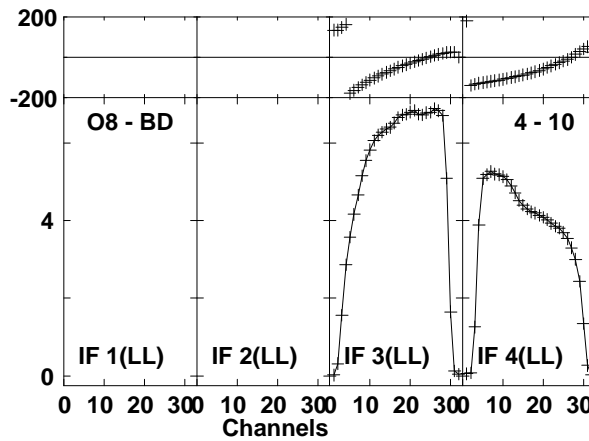
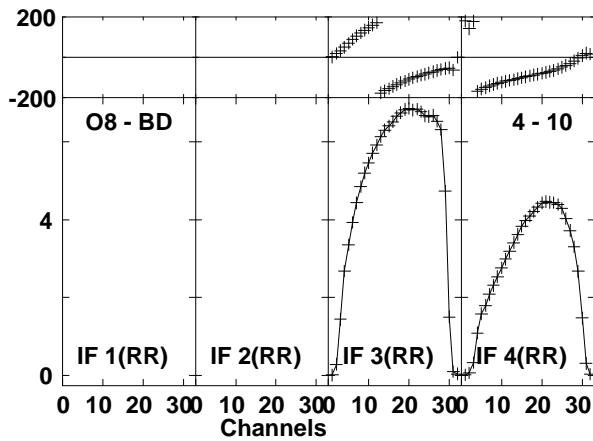
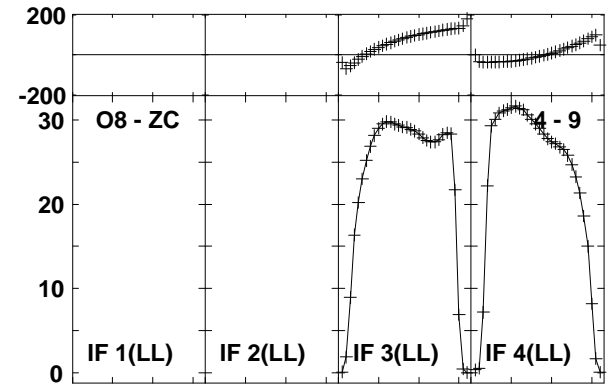
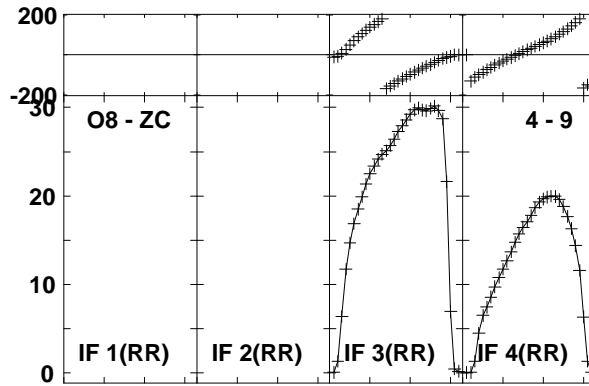
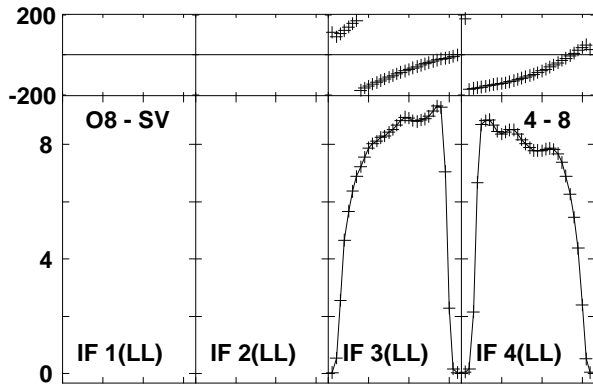
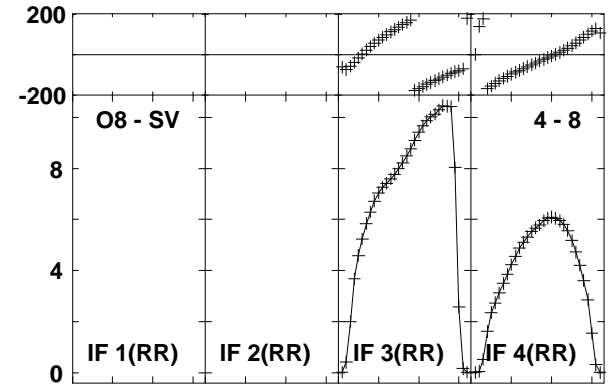
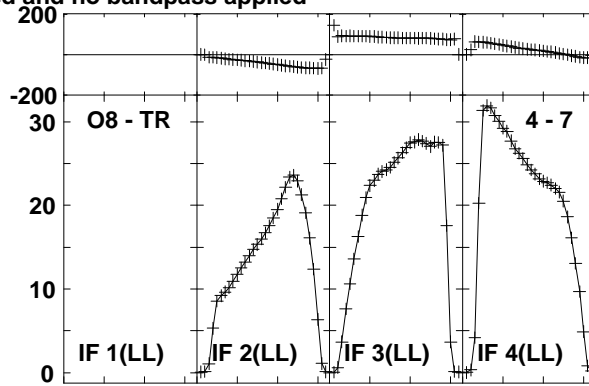
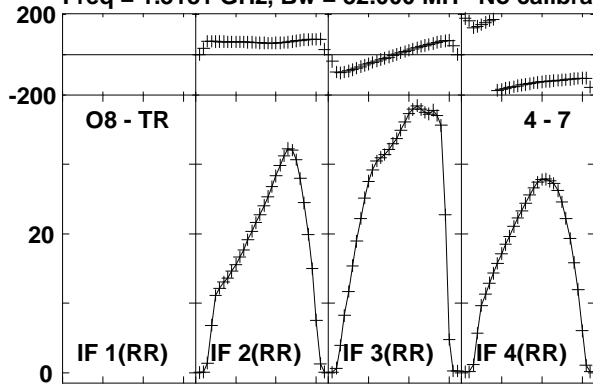

Lower frame: Milli Ampl Jy Top frame: Phas deg
Vector averaged cross-power spectrum Baseline: O8 (04) - TR (07)
Timerange: 00/11:14:48 to 00/11:24:43

Plot file version 144 created 20-NOV-2015 13:44:00

3C84 EO013 1.UVDATA.1

Freq = 1.3181 GHz, Bw = 32.000 MH No calibration applied and no bandpass applied

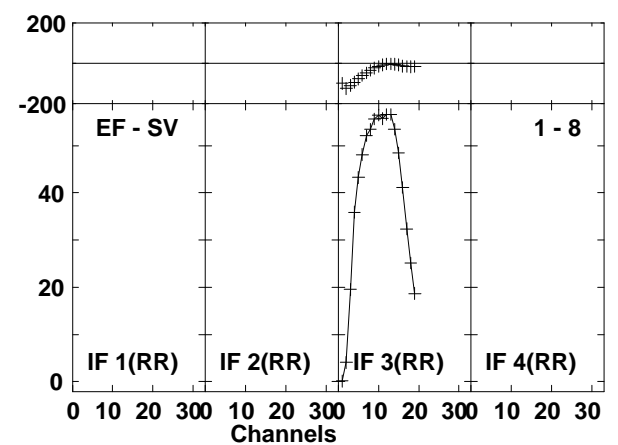
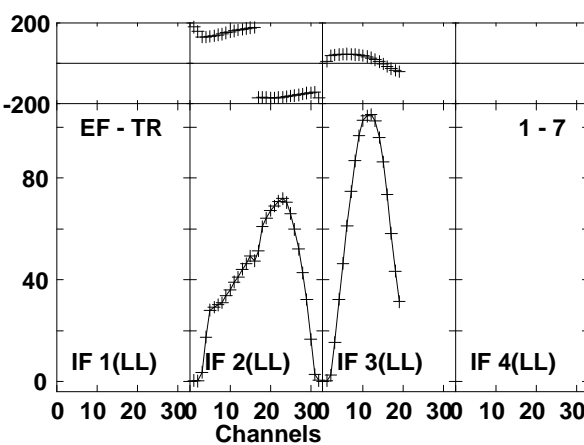
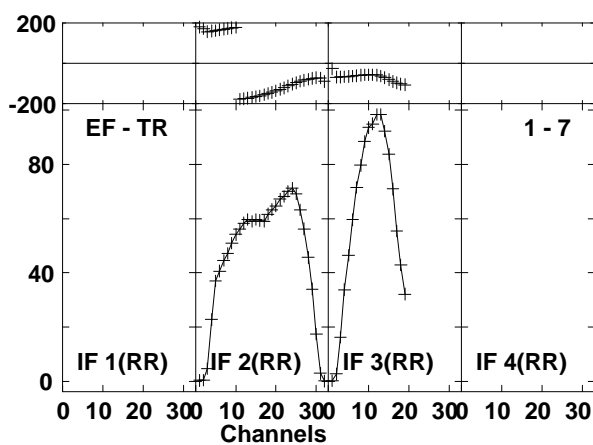
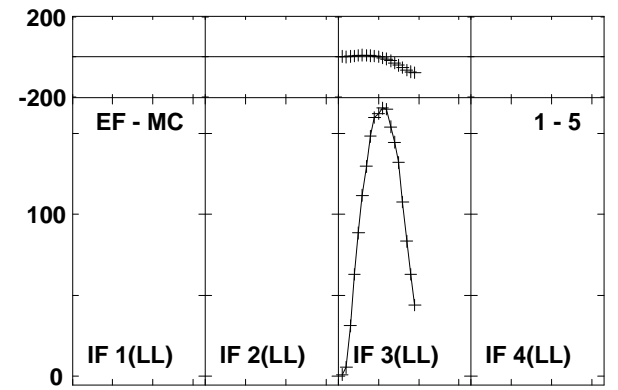
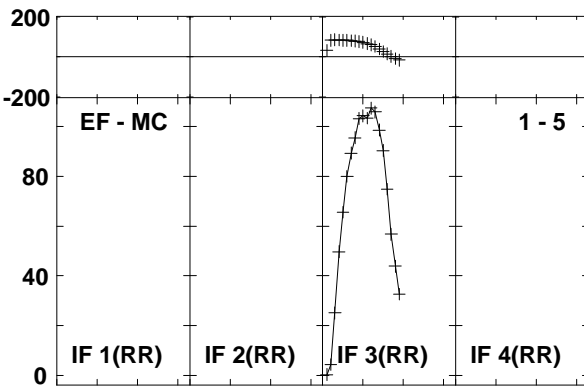
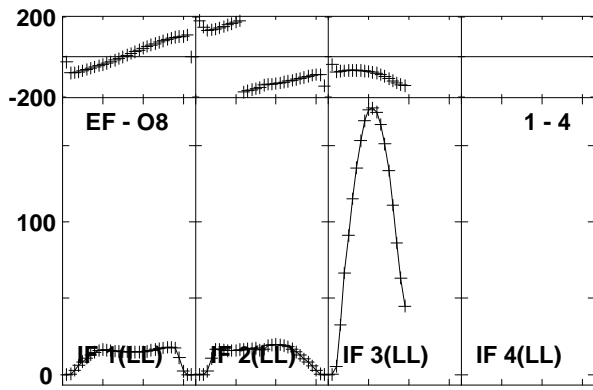
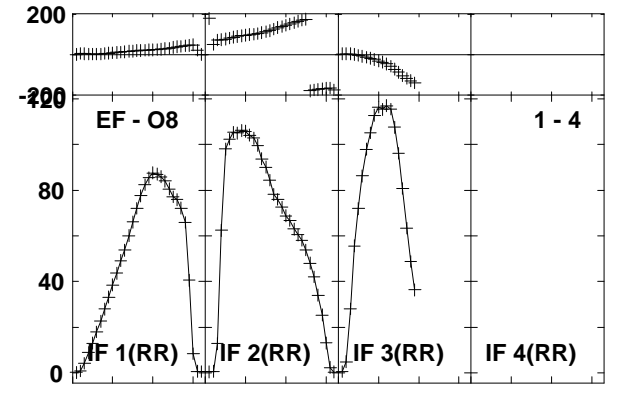
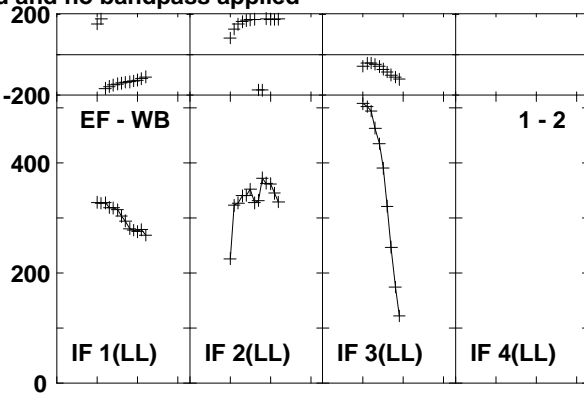
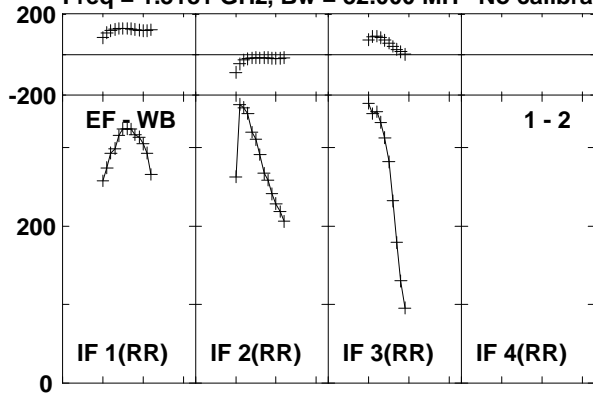

Lower frame: Milli Ampl Jy Top frame: Phas deg
Vector averaged cross-power spectrum Baseline: EF (01) - WB (02)
Timerange: 00/11:25:18 to 00/11:35:14

Plot file version 145 created 20-NOV-2015 13:44:00
 3C84 EO013 1.UVDATA.1
 Freq = 1.3181 GHz, Bw = 32.000 MH No calibration applied and no bandpass applied

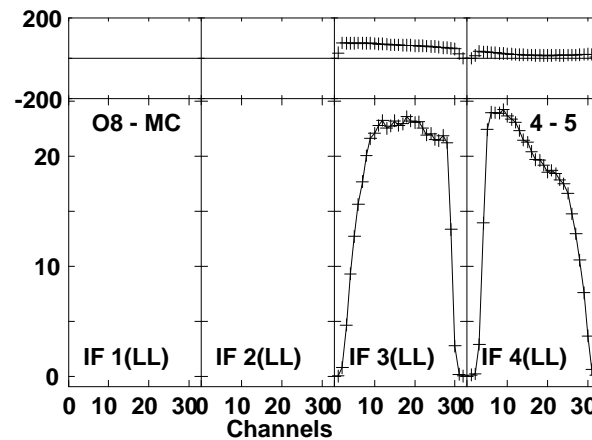
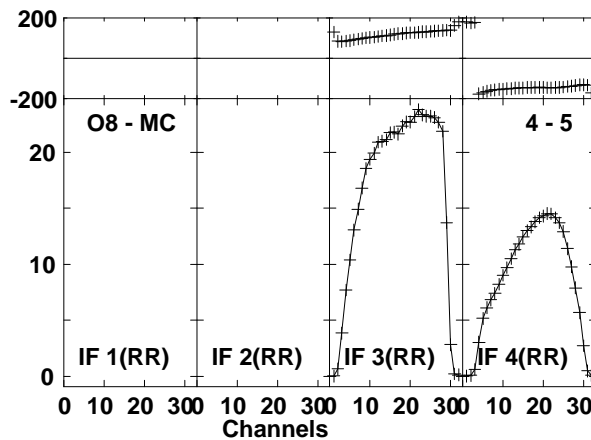
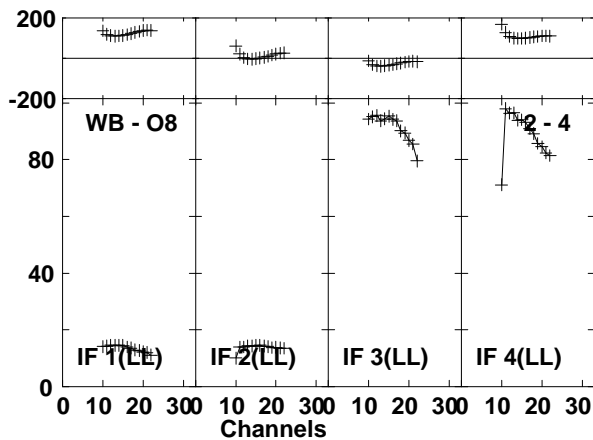
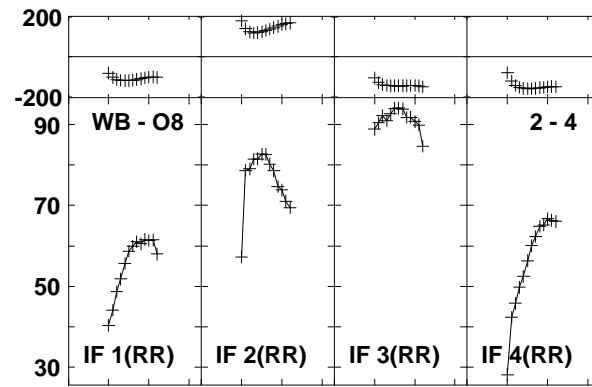
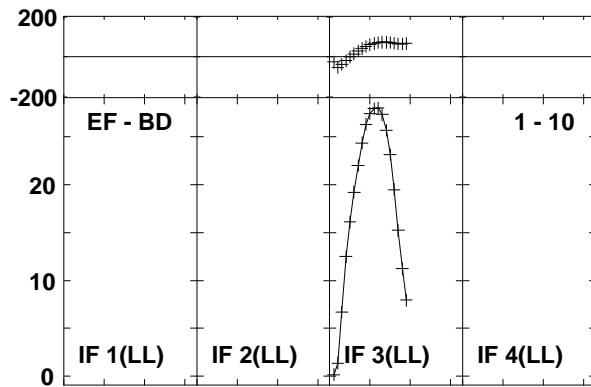
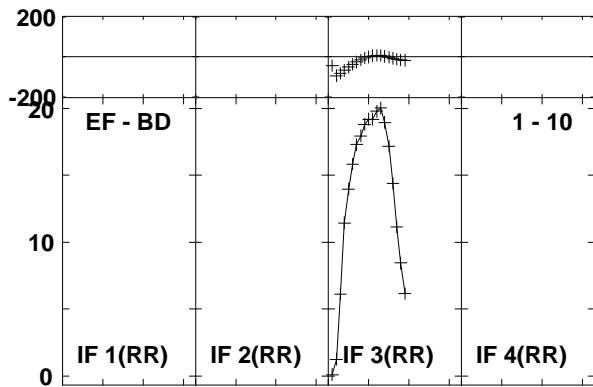
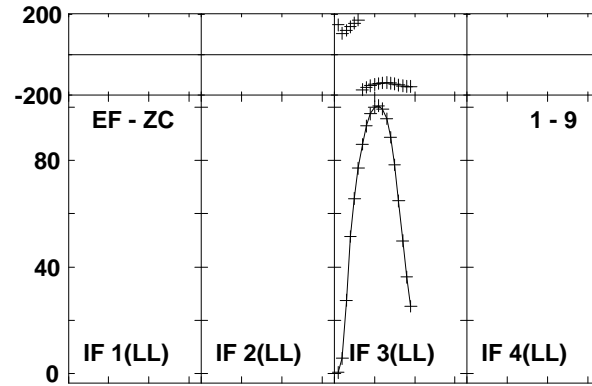
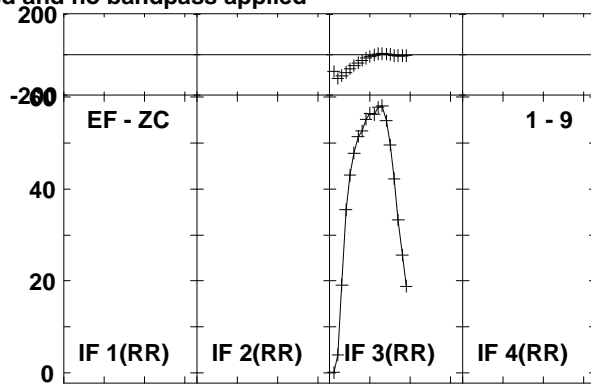
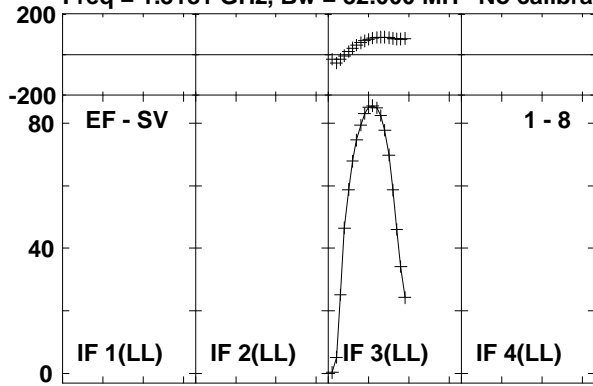

Lower frame: Milli Ampl Jy Top frame: Phas deg
 Vector averaged cross-power spectrum Baseline: EF (01) - SV (08)
 Timerange: 00/11:25:18 to 00/11:35:14

Plot file version 146 created 20-NOV-2015 13:44:00
 3C84 EO013 1.UVDATA.1
 Freq = 1.3181 GHz, Bw = 32.000 MH No calibration applied and no bandpass applied

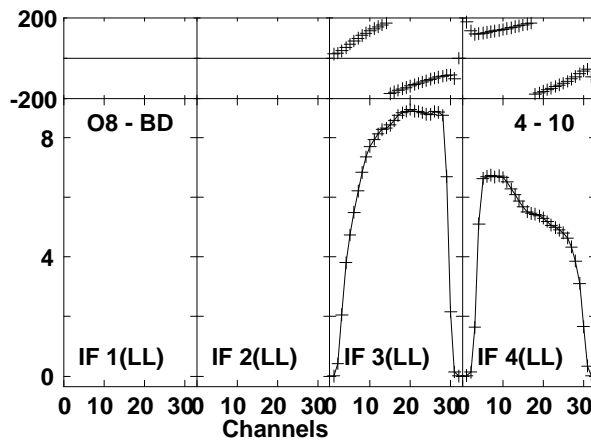
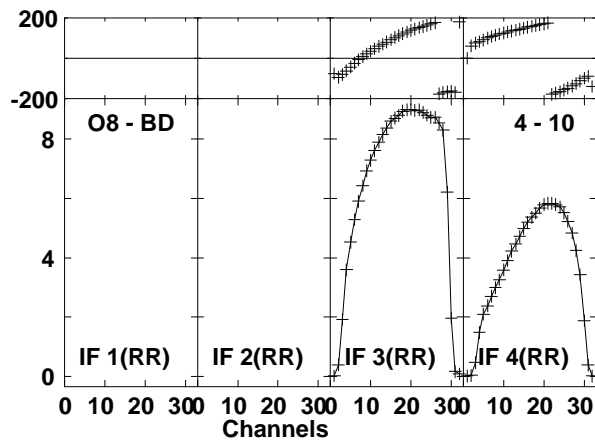
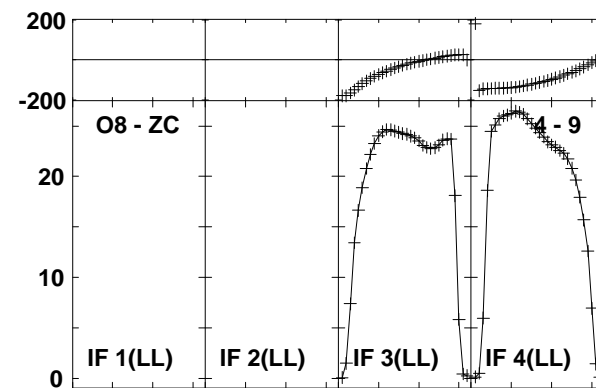
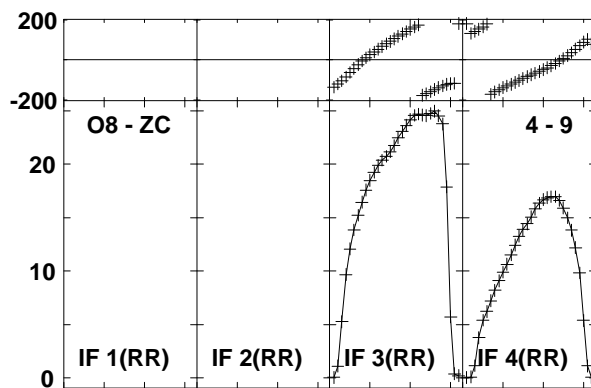
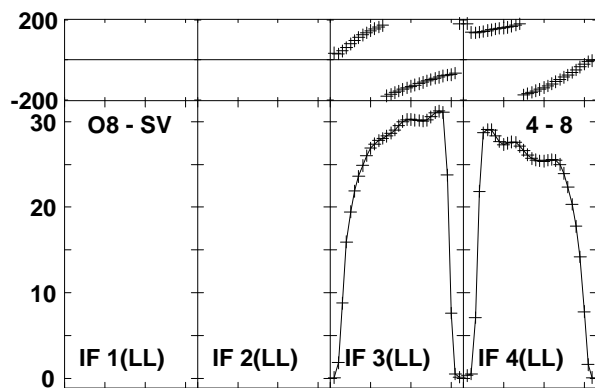
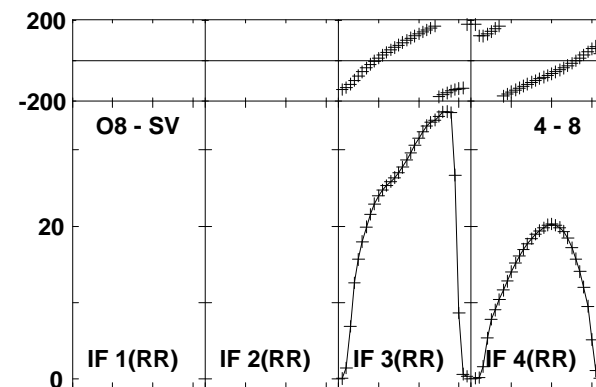
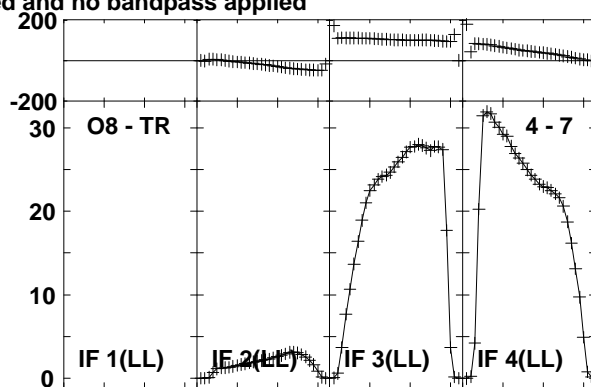
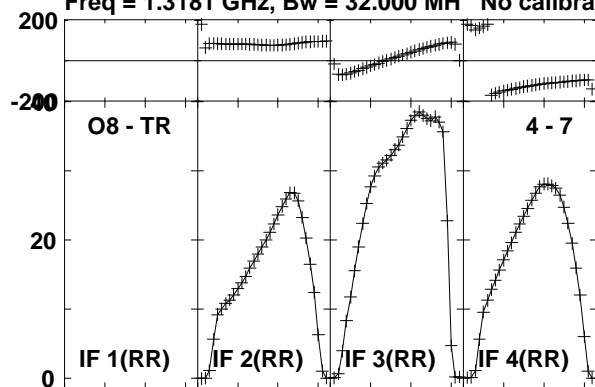

Lower frame: Milli Ampl Jy Top frame: Phas deg
 Vector averaged cross-power spectrum Baseline: O8 (04) - TR (07)
 Timerange: 00/11:25:18 to 00/11:35:14

Plot file version 147 created 20-NOV-2015 13:44:00

3C84 EO013 1.UVDATA.1

Freq = 1.3181 GHz, Bw = 32.000 MH No calibration applied and no bandpass applied

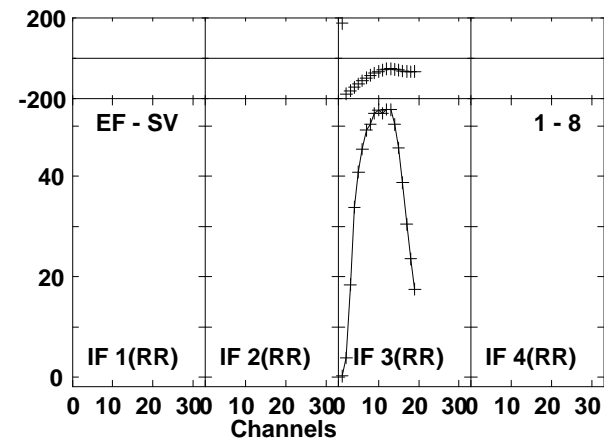
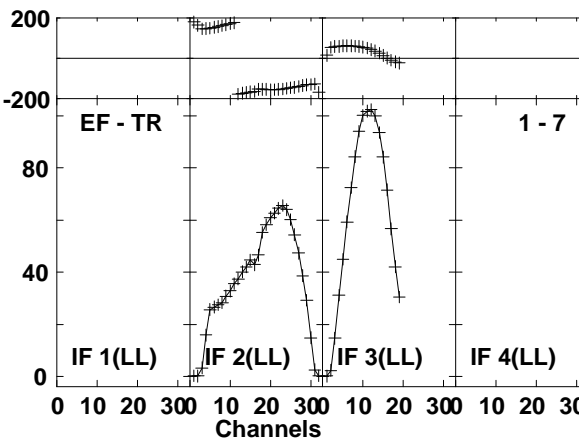
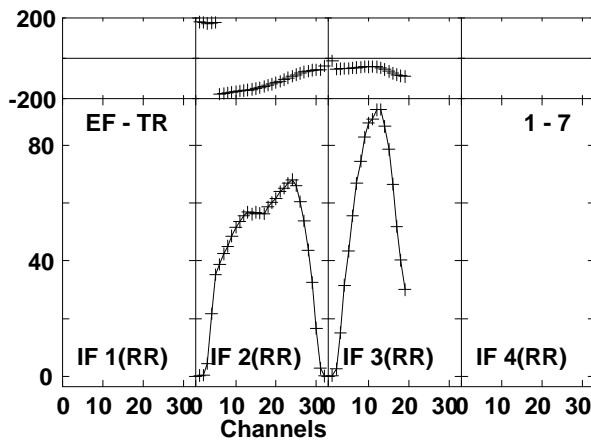
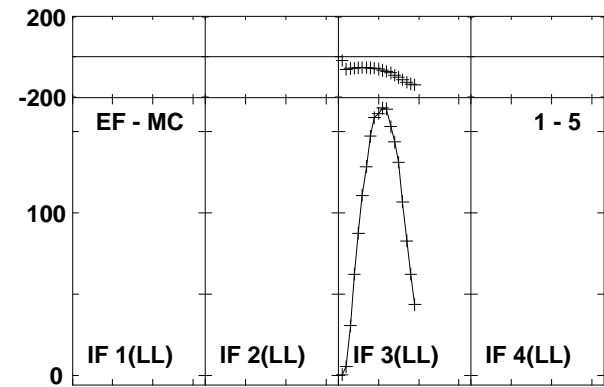
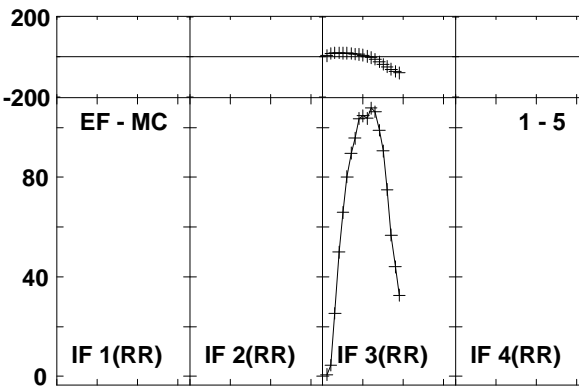
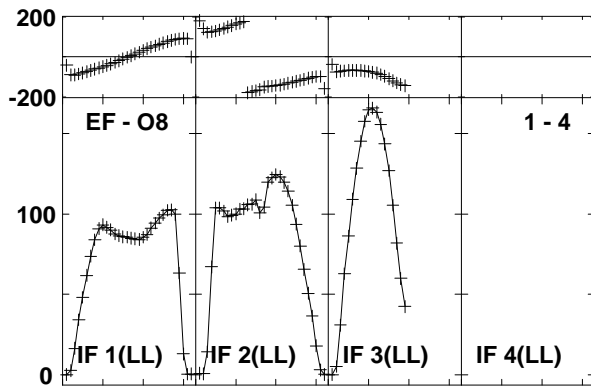
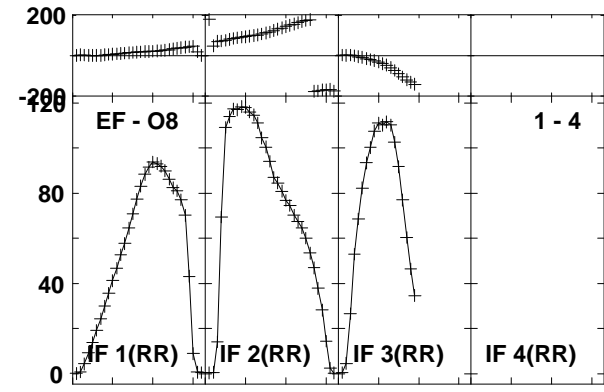
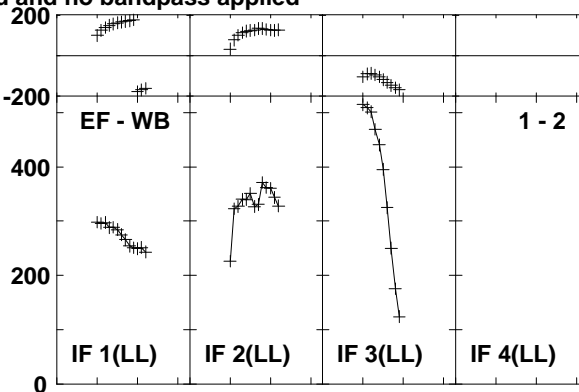
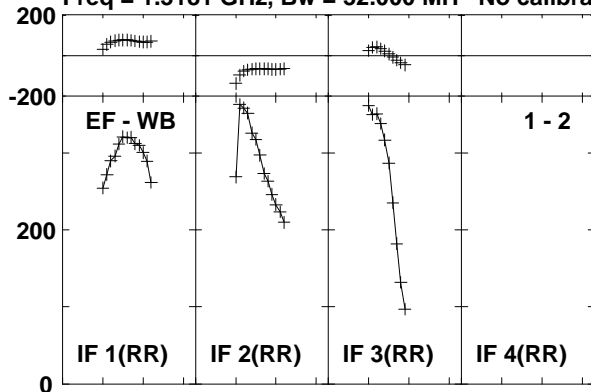

Lower frame: Milli Ampl Jy Top frame: Phas deg
Vector averaged cross-power spectrum Baseline: EF (01) - WB (02)
Timerange: 00/11:35:48 to 00/11:45:44

Plot file version 148 created 20-NOV-2015 13:44:00
 3C84 EO013 1.UVDATA.1
 Freq = 1.3181 GHz, Bw = 32.000 MH No calibration applied and no bandpass applied

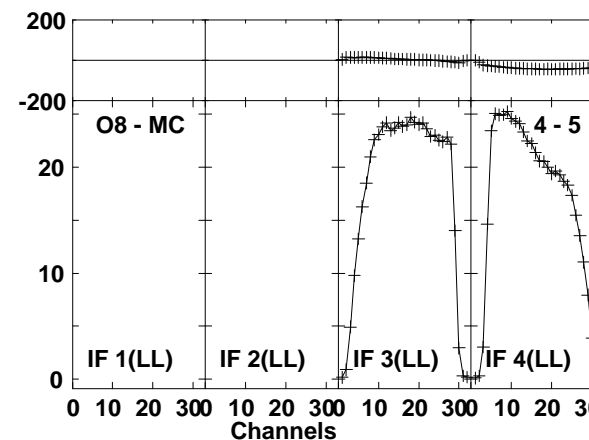
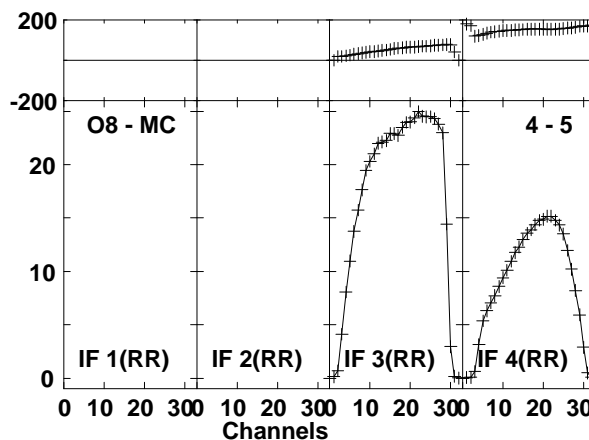
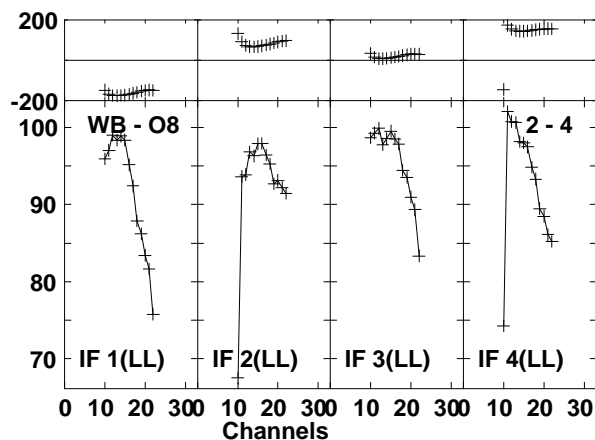
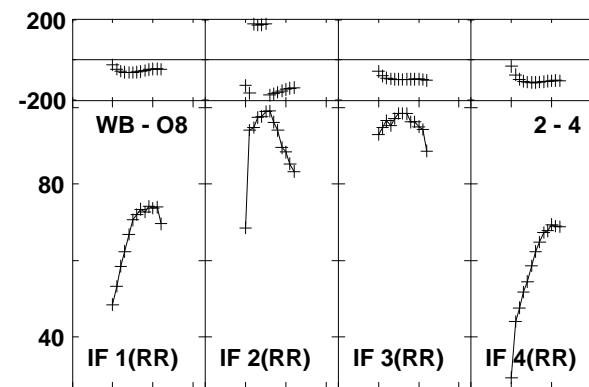
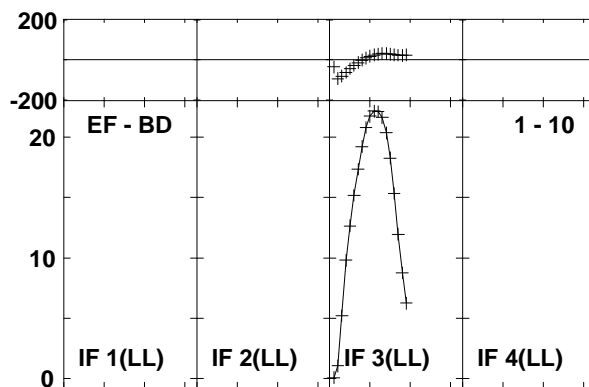
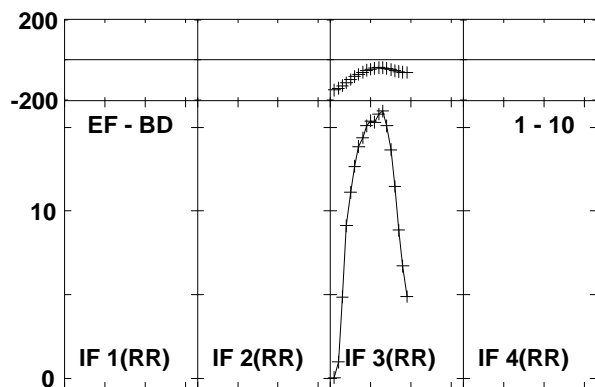
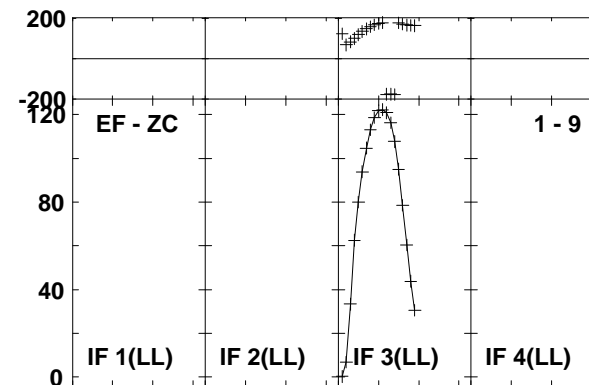
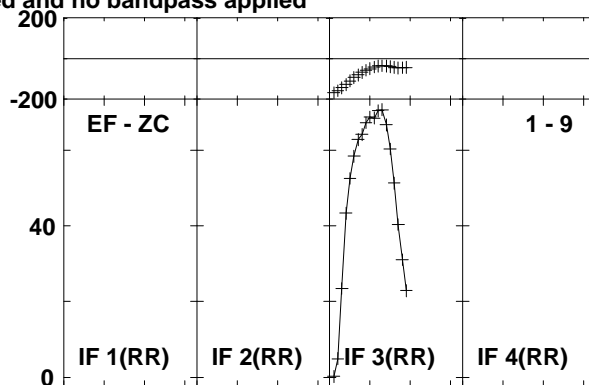
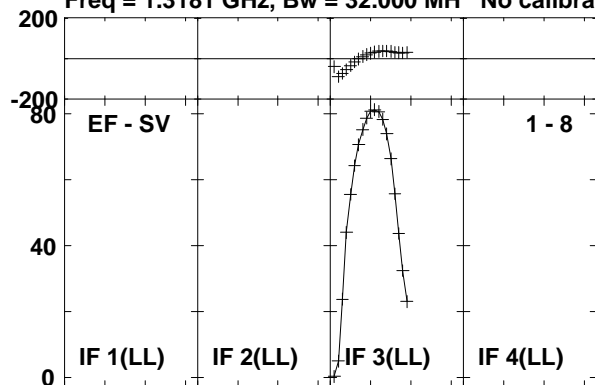

Lower frame: Milli Ampl Jy Top frame: Phas deg
 Vector averaged cross-power spectrum Baseline: EF (01) - SV (08)
 Timerange: 00/11:35:48 to 00/11:45:44

Plot file version 149 created 20-NOV-2015 13:44:00
 3C84 EO013 1.UVDATA.1
 Freq = 1.3181 GHz, Bw = 32.000 MH No calibration applied and no bandpass applied

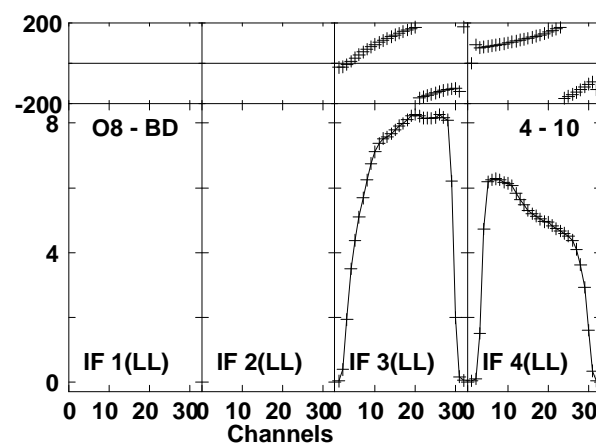
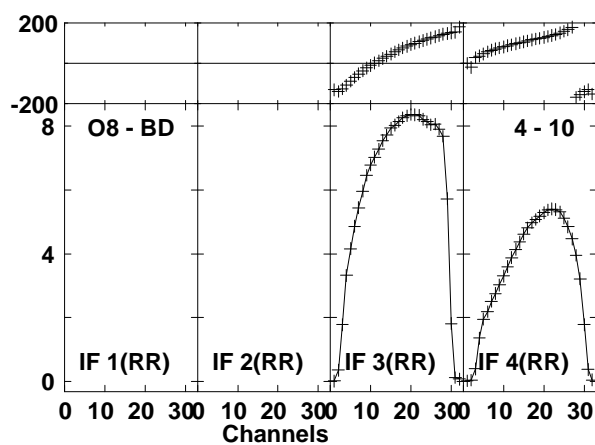
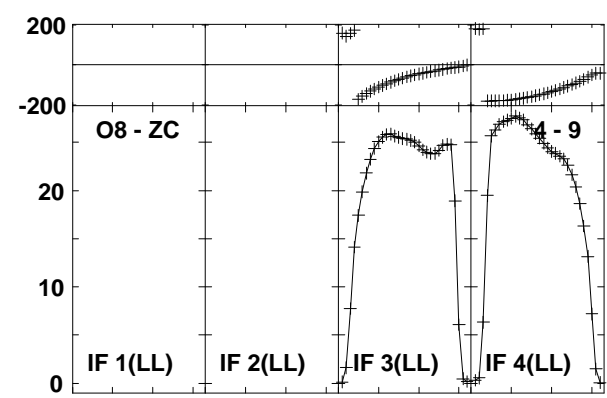
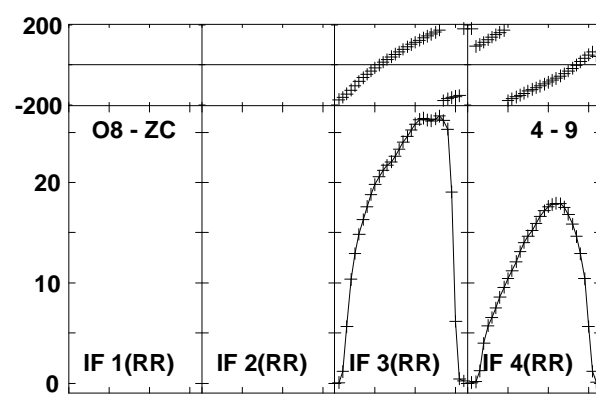
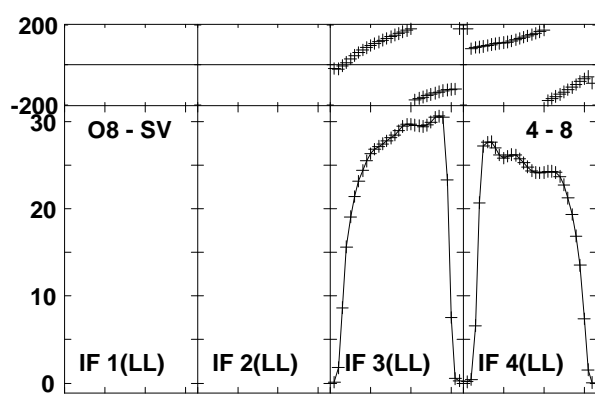
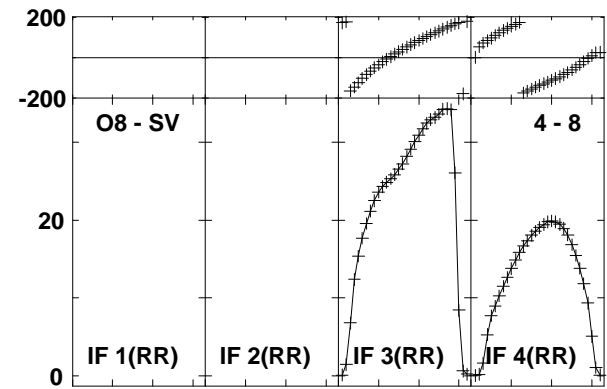
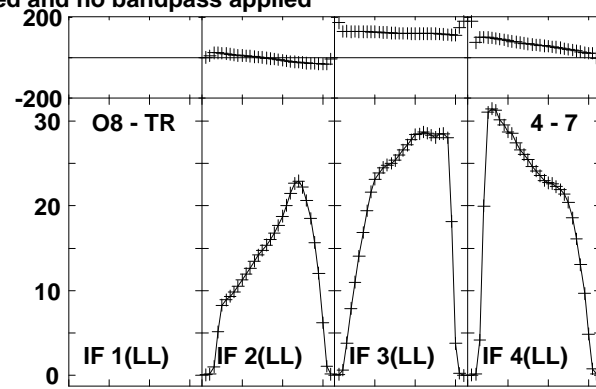
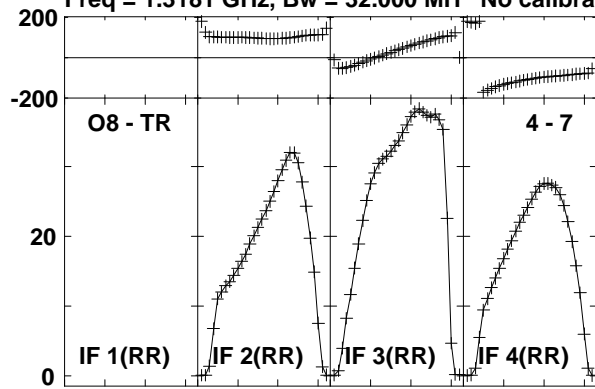

Lower frame: Milli Ampl Jy Top frame: Phas deg
 Vector averaged cross-power spectrum Baseline: O8 (04) - TR (07)
 Timerange: 00/11:35:48 to 00/11:45:44

Plot file version 150 created 20-NOV-2015 13:44:00
 3C84 EO013 1.UVDATA.1

Freq = 1.3181 GHz, Bw = 32.000 MH No calibration applied and no bandpass applied

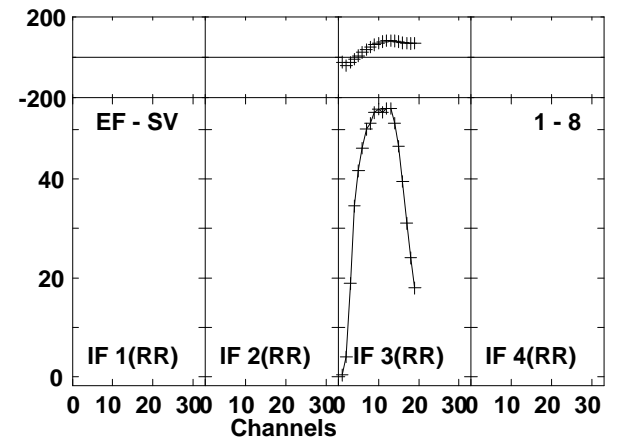
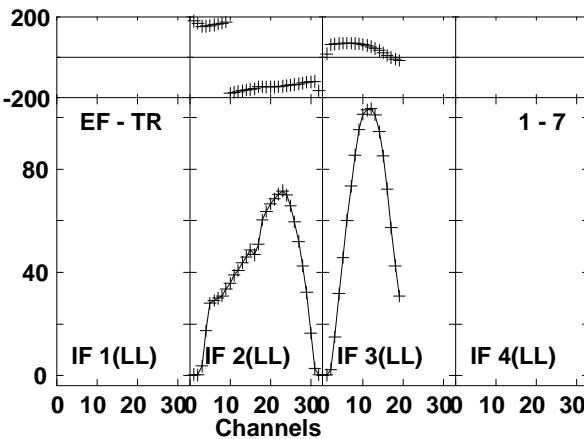
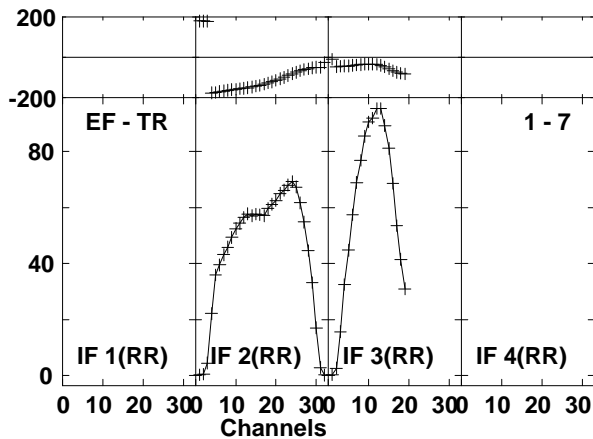
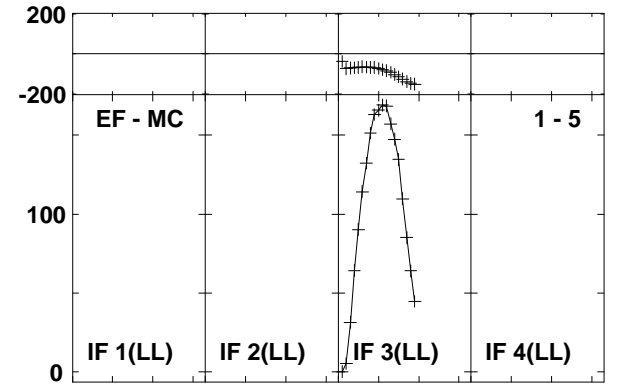
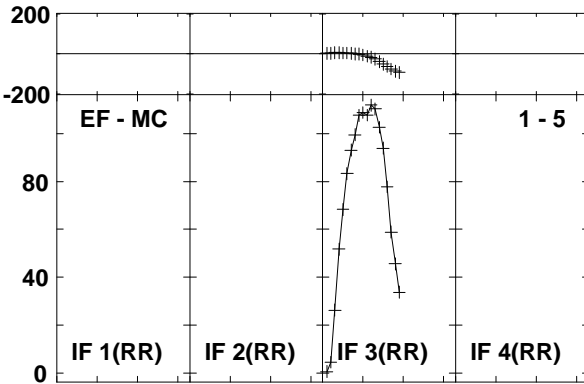
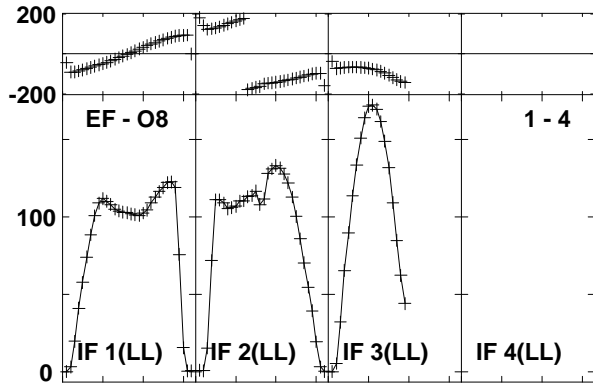
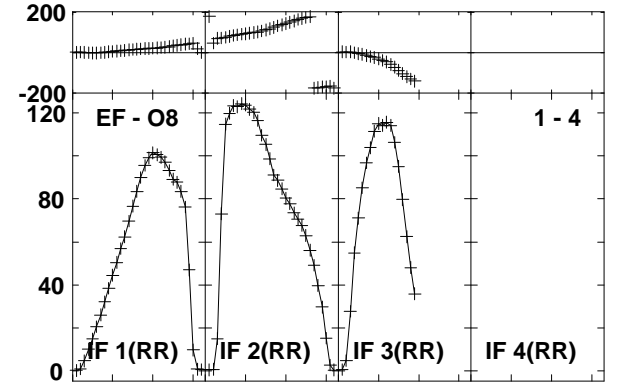
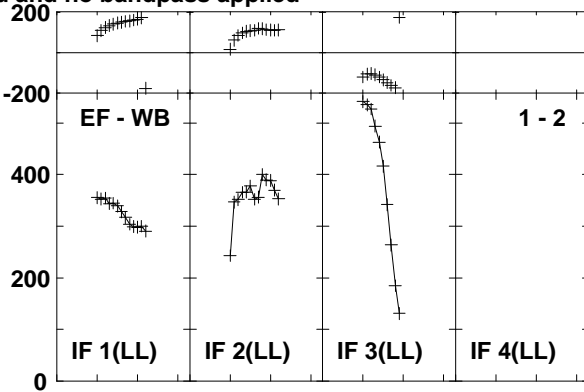
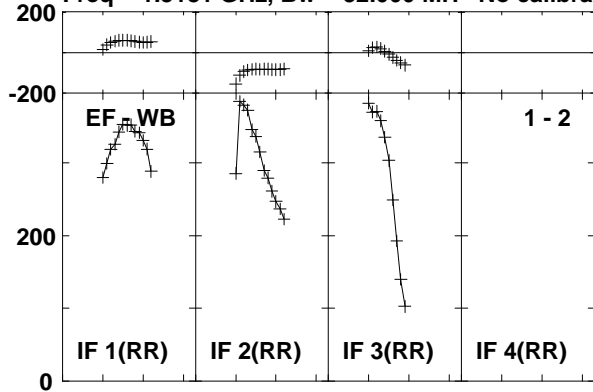

Lower frame: Milli Ampl Jy Top frame: Phas deg
 Vector averaged cross-power spectrum Baseline: EF (01) - WB (02)
 Timerange: 00/11:46:18 to 00/11:56:14

Plot file version 151 created 20-NOV-2015 13:44:00
 3C84 EO013 1.UVDATA.1
 Freq = 1.3181 GHz, Bw = 32.000 MH No calibration applied and no bandpass applied

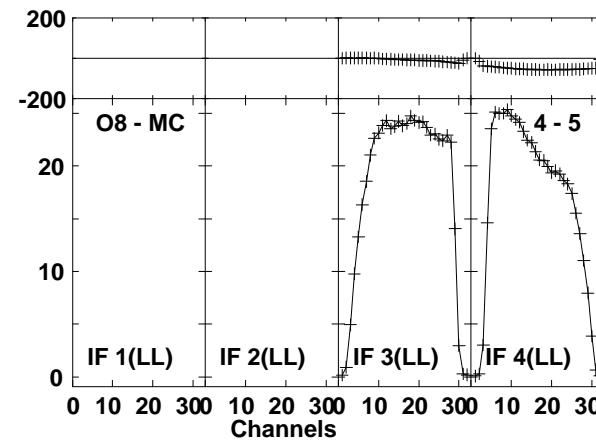
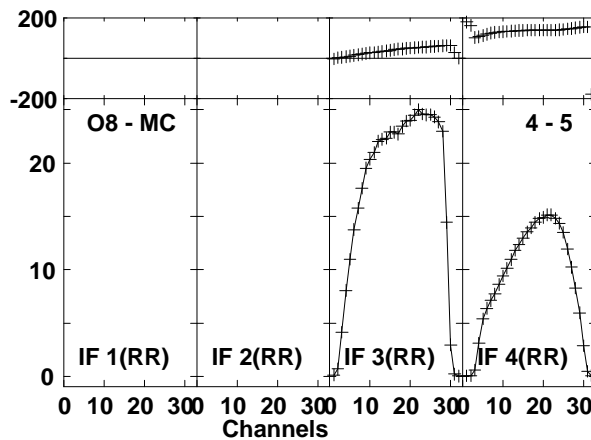
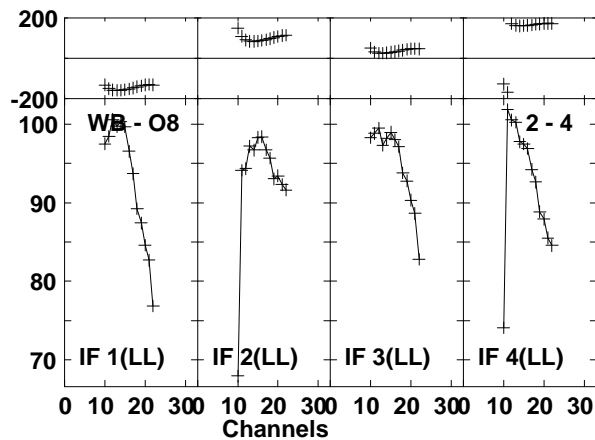
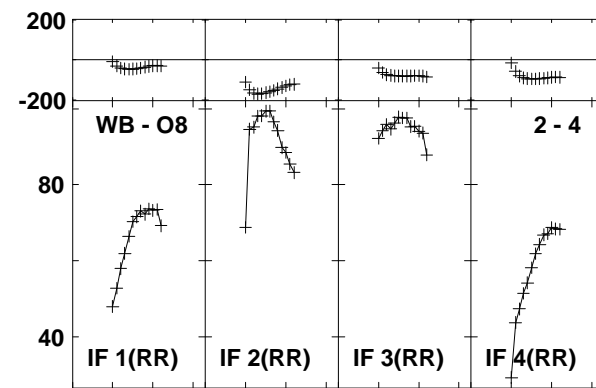
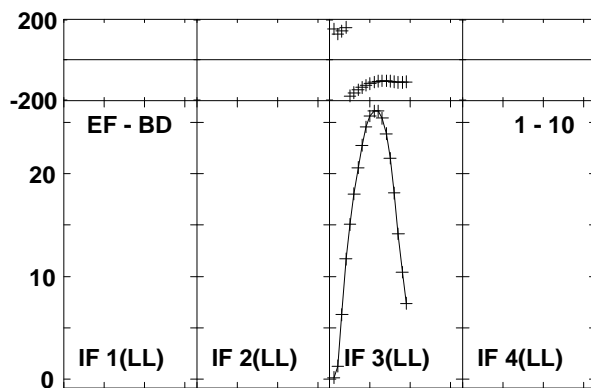
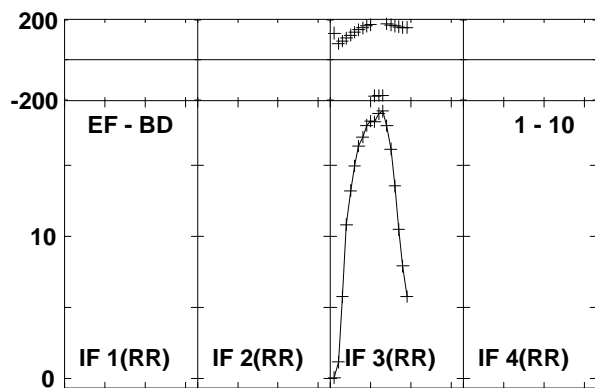
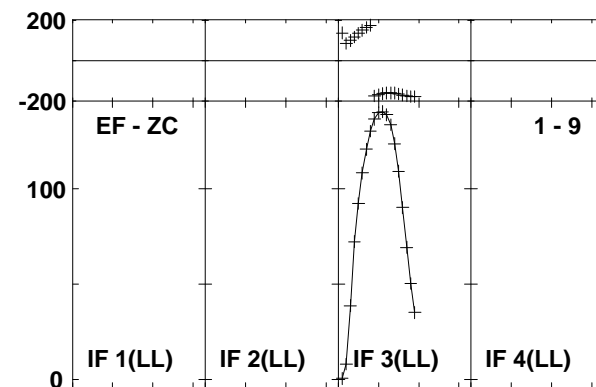
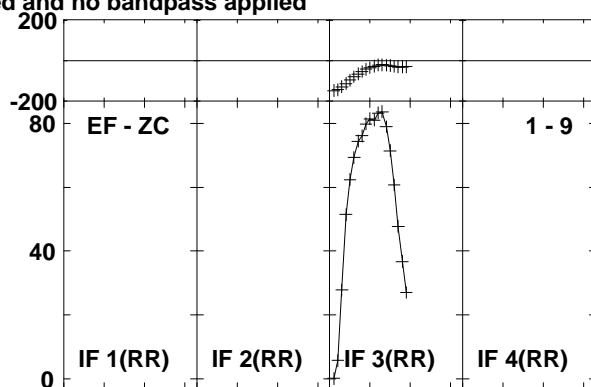
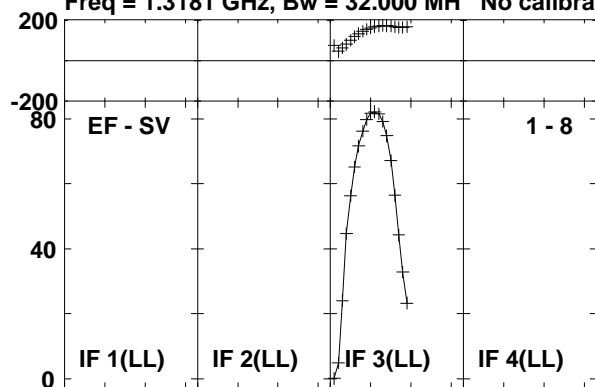

Lower frame: Milli Ampl Jy Top frame: Phas deg
 Vector averaged cross-power spectrum Baseline: EF (01) - SV (08)
 Timerange: 00/11:46:18 to 00/11:56:14

Plot file version 152 created 20-NOV-2015 13:44:01
 3C84 EO013 1.UVDATA.1
 Freq = 1.3181 GHz, Bw = 32.000 MH No calibration applied and no bandpass applied

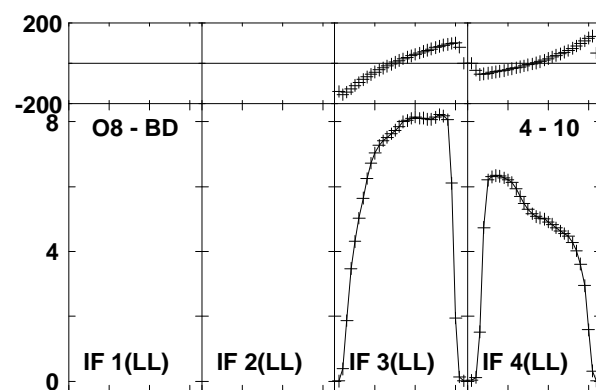
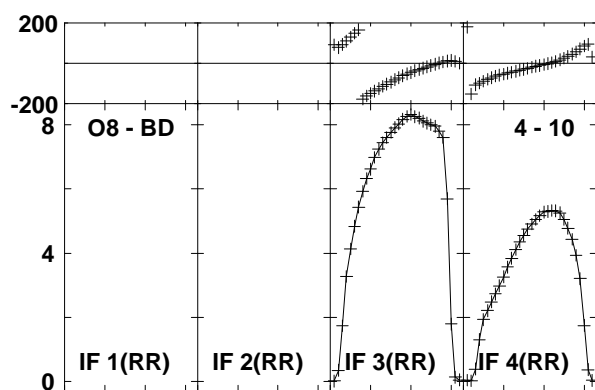
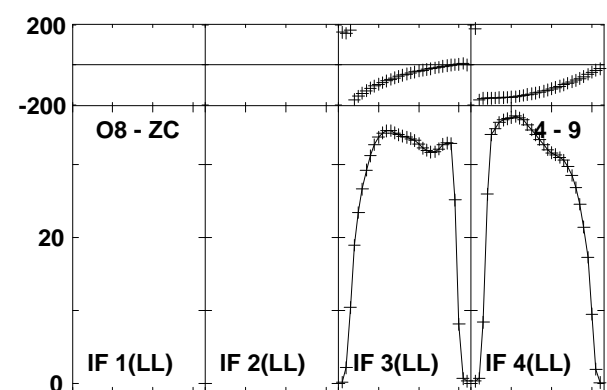
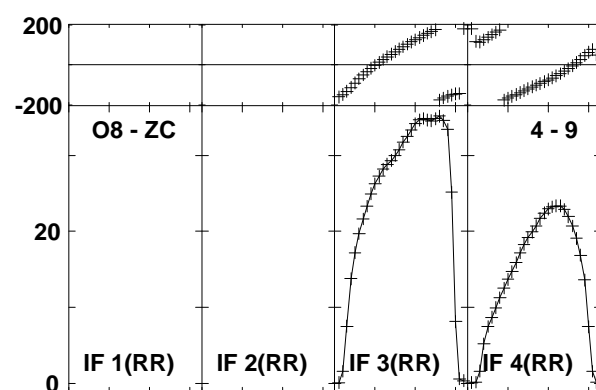
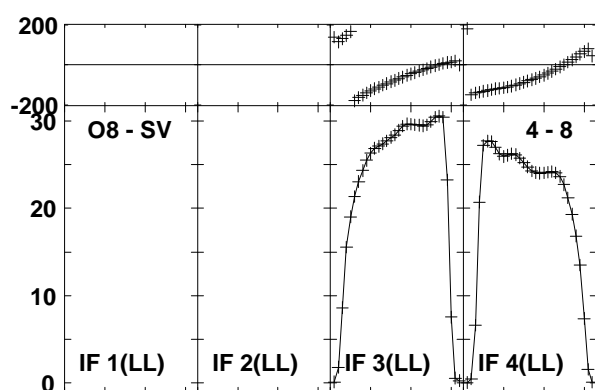
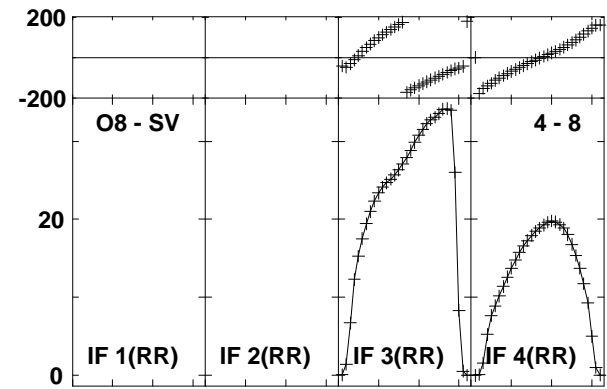
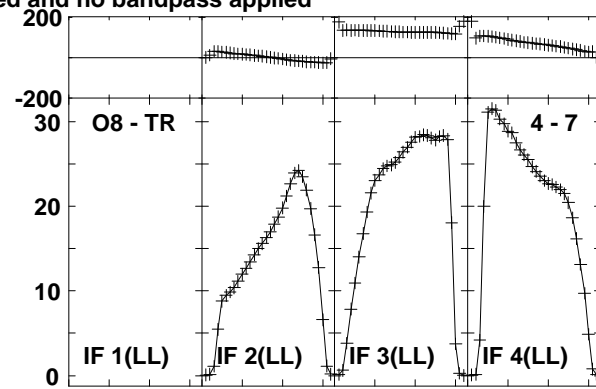
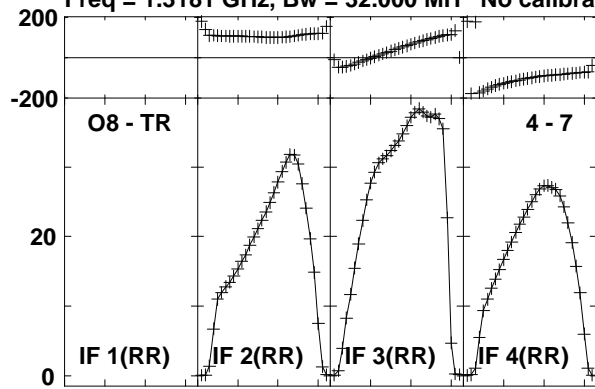

Lower frame: Milli Ampl Jy Top frame: Phas deg
 Vector averaged cross-power spectrum Baseline: O8 (04) - TR (07)
 Timerange: 00/11:46:18 to 00/11:56:14

Plot file version 153 created 20-NOV-2015 13:44:01

3C84 EO013 1.UVDATA.1

Freq = 1.3181 GHz, Bw = 32.000 MH No calibration applied and no bandpass applied

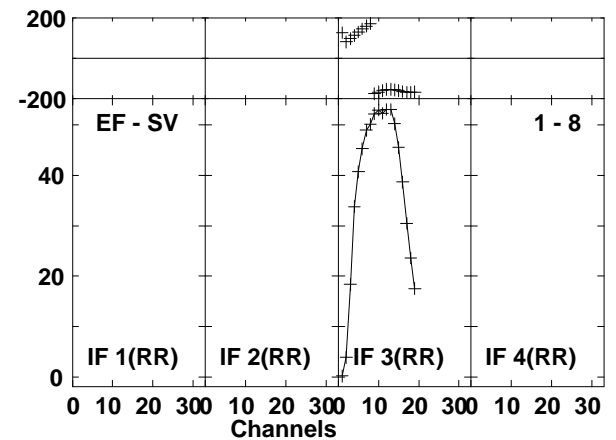
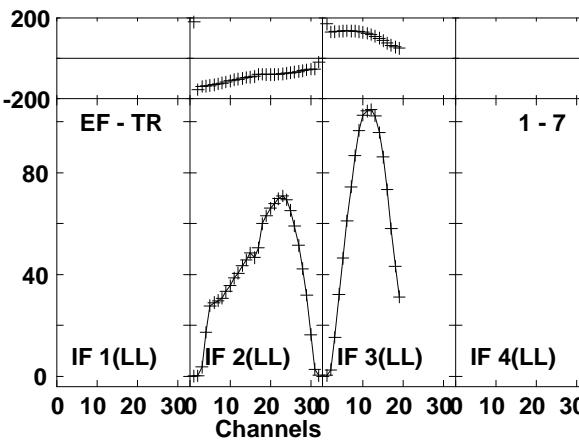
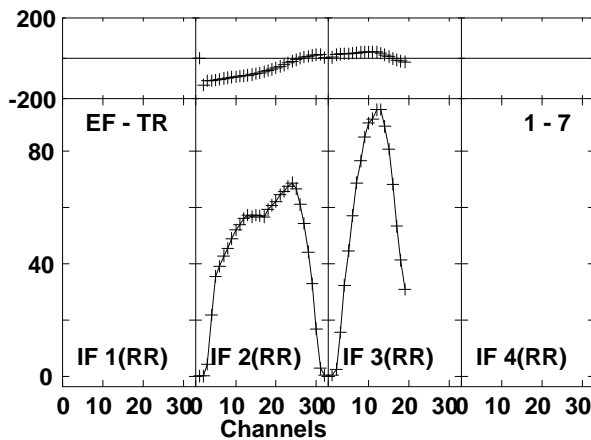
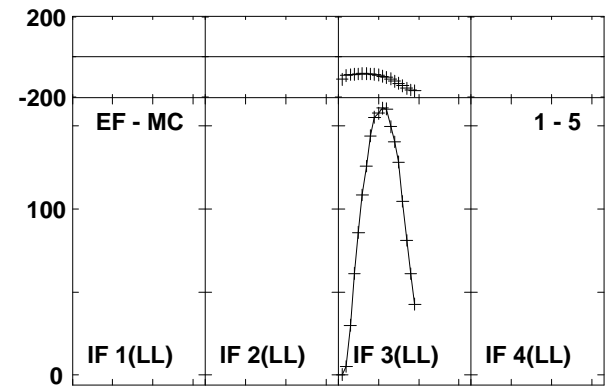
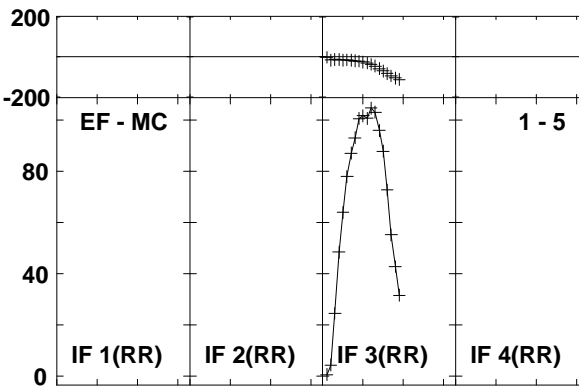
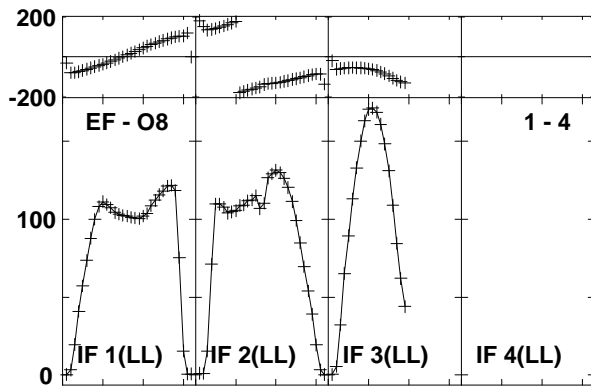
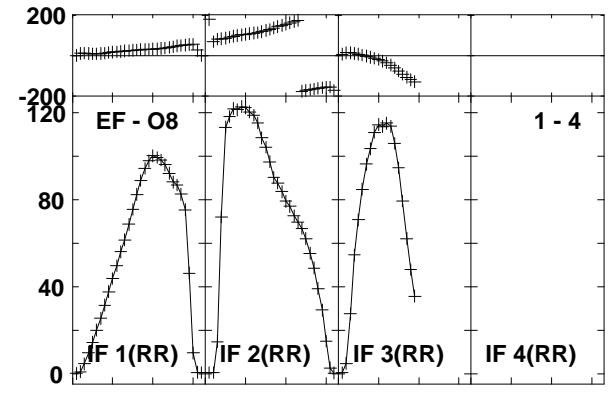
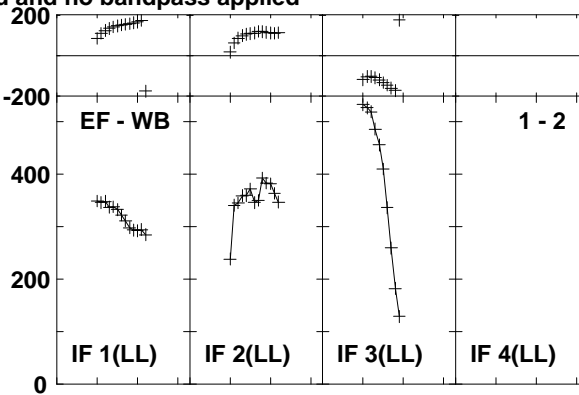
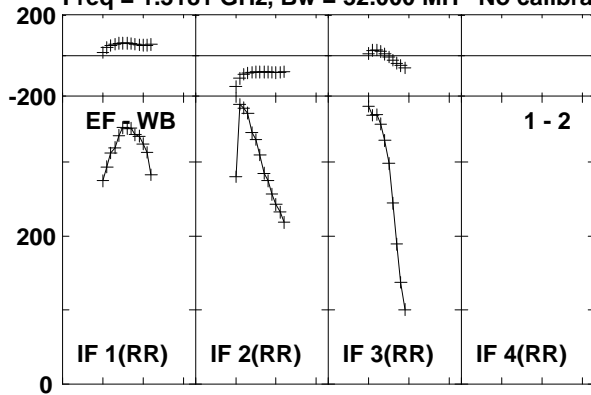

Lower frame: Milli Ampl Jy Top frame: Phas deg
Vector averaged cross-power spectrum Baseline: EF (01) - WB (02)
Timerange: 00/11:56:48 to 00/12:06:44

Plot file version 154 created 20-NOV-2015 13:44:01
 3C84 EO013 1.UVDATA.1
 Freq = 1.3181 GHz, Bw = 32.000 MH No calibration applied and no bandpass applied

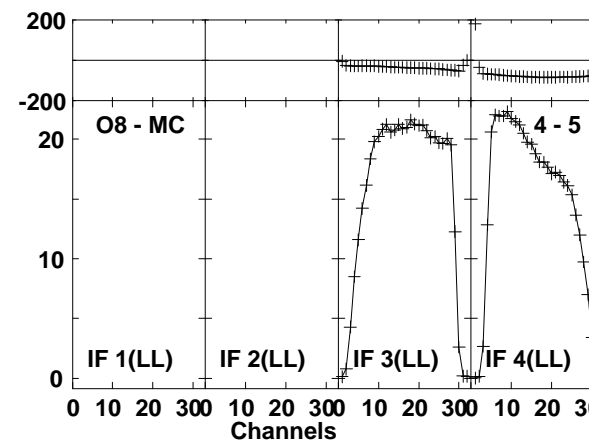
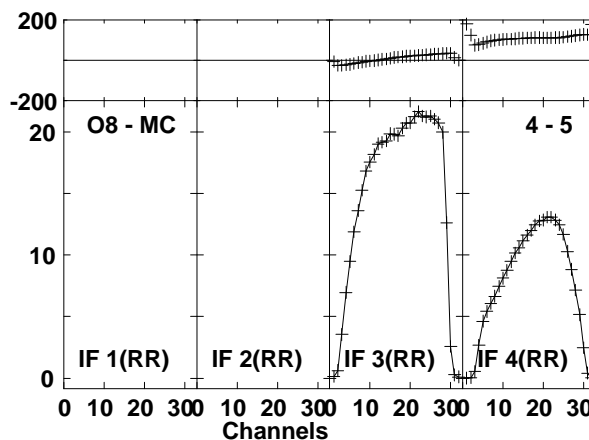
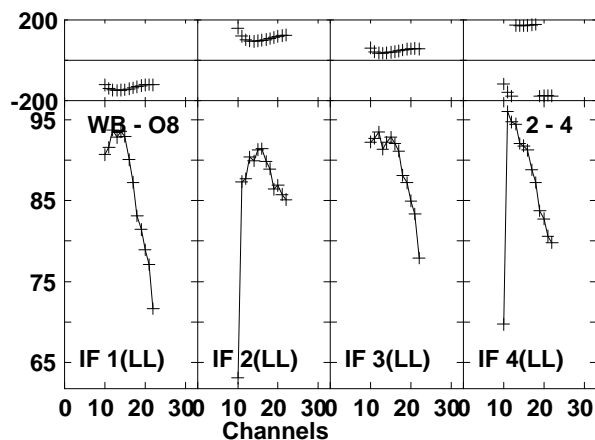
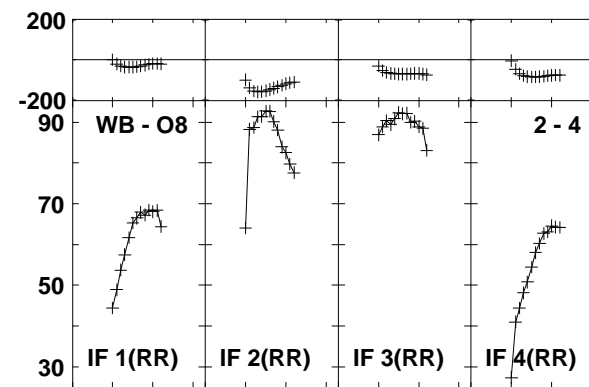
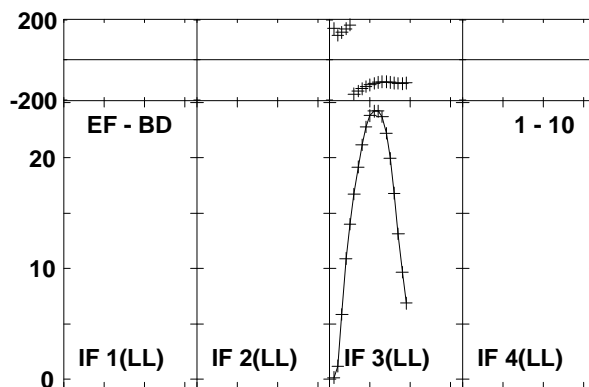
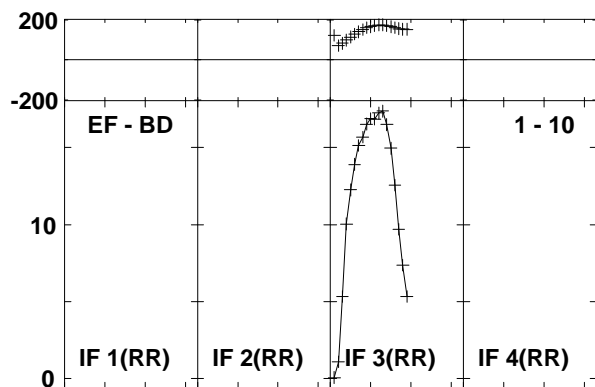
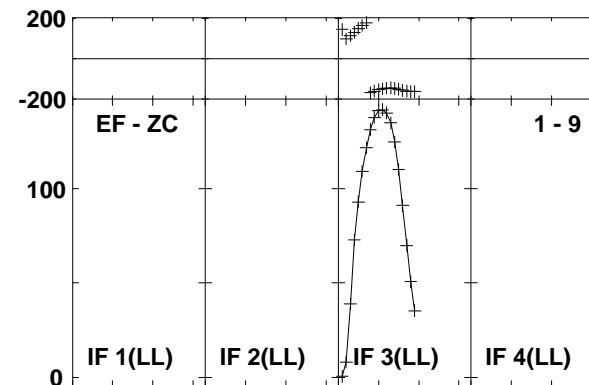
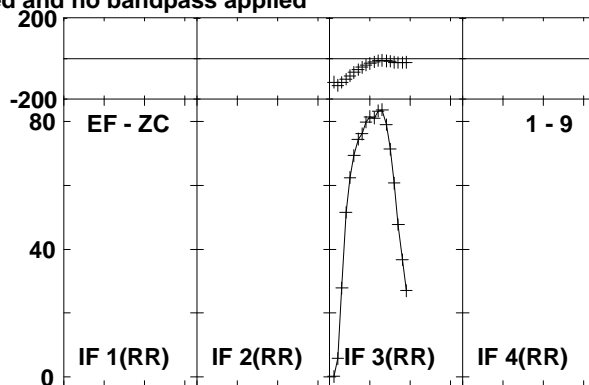
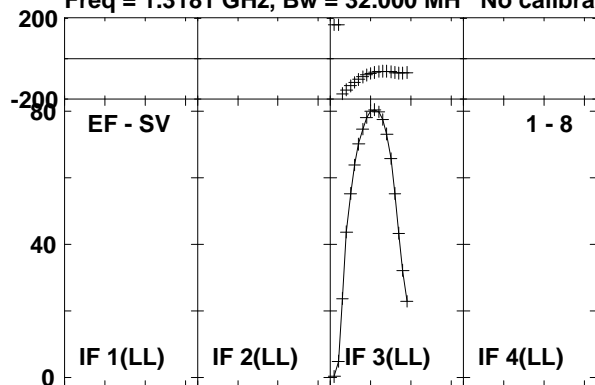

Lower frame: Milli Ampl Jy Top frame: Phas deg
 Vector averaged cross-power spectrum Baseline: EF (01) - SV (08)
 Timerange: 00/11:56:48 to 00/12:06:44

Plot file version 155 created 20-NOV-2015 13:44:01

3C84 EO013 1.UVDATA.1

Freq = 1.3181 GHz, Bw = 32.000 MH No calibration applied and no bandpass applied

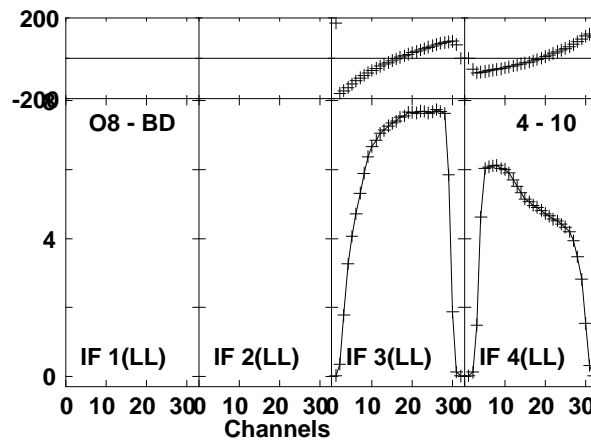
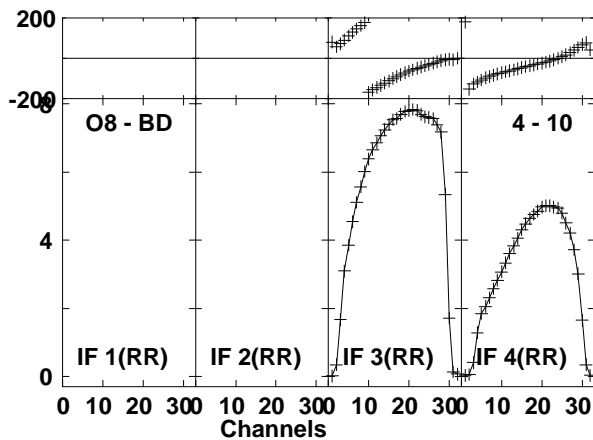
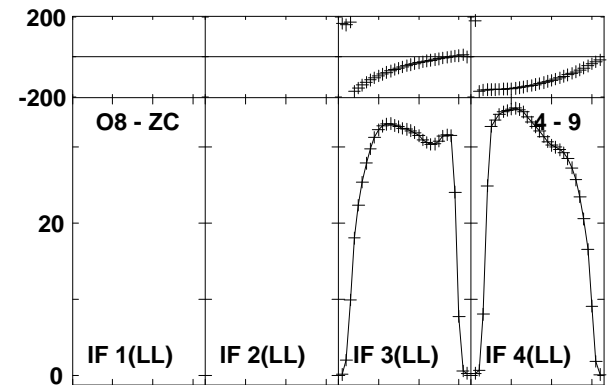
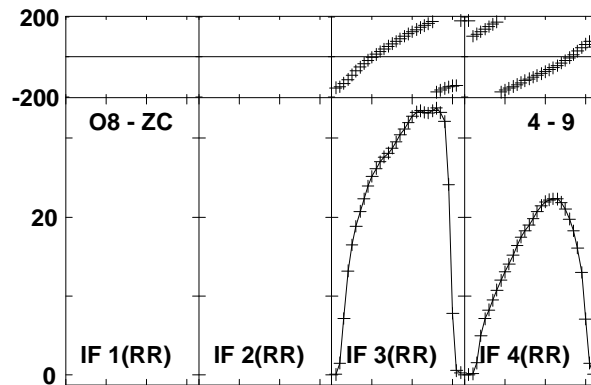
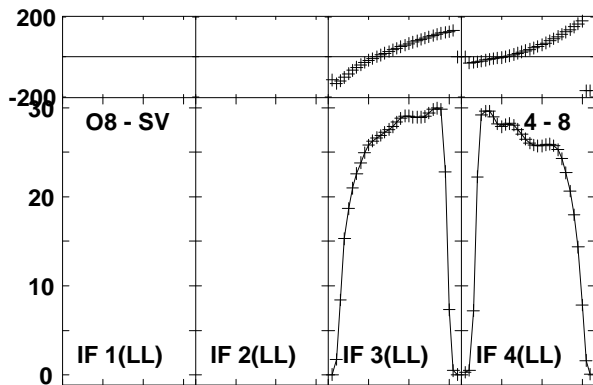
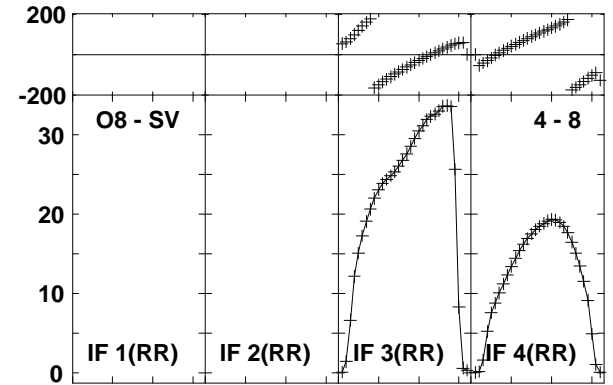
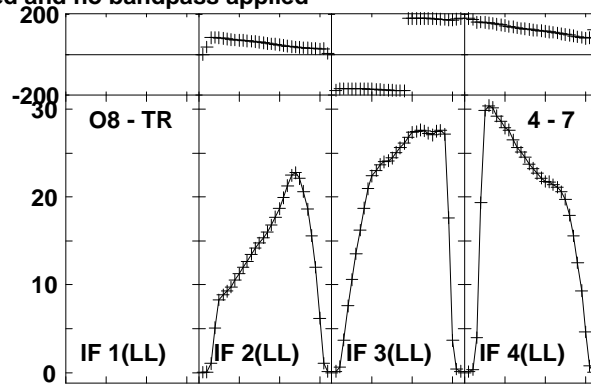
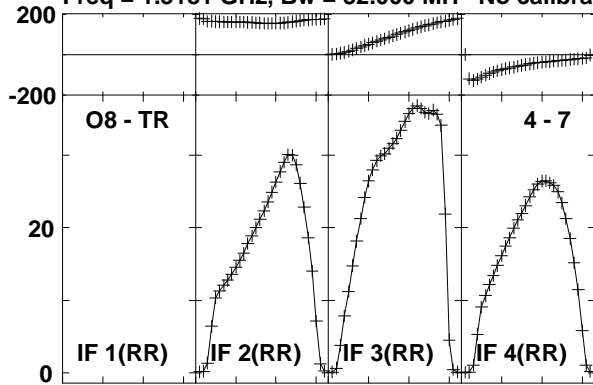

Lower frame: Milli Ampl Jy Top frame: Phas deg
Vector averaged cross-power spectrum Baseline: O8 (04) - TR (07)
Timerange: 00/11:56:48 to 00/12:06:44

Plot file version 156 created 20-NOV-2015 13:44:01

DA193 EO013 1.UVDATA.1

Freq = 1.3181 GHz, Bw = 32.000 MH No calibration applied and no bandpass applied

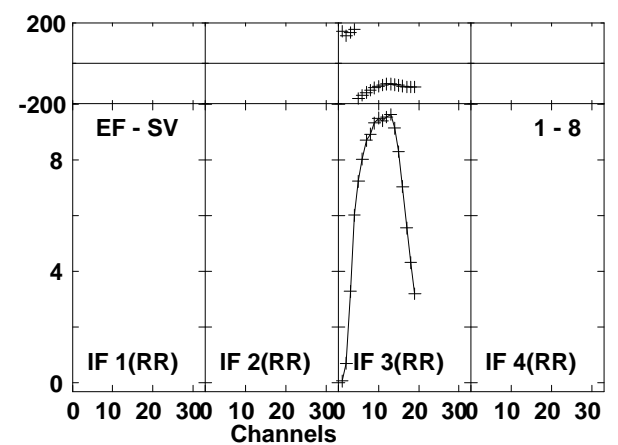
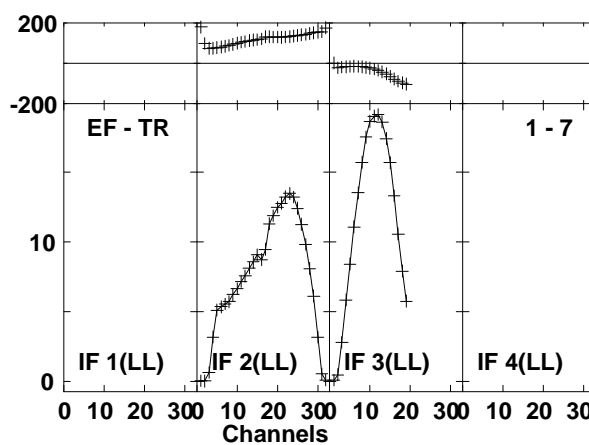
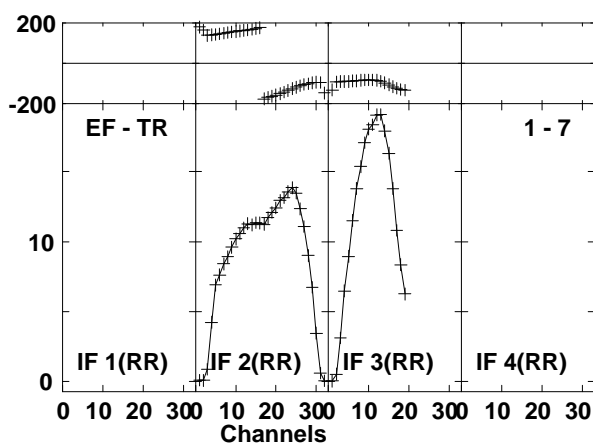
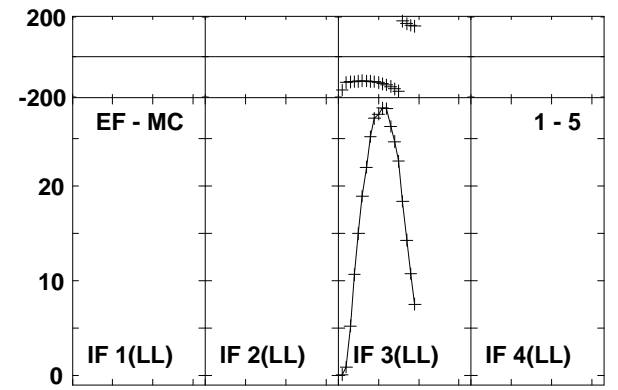
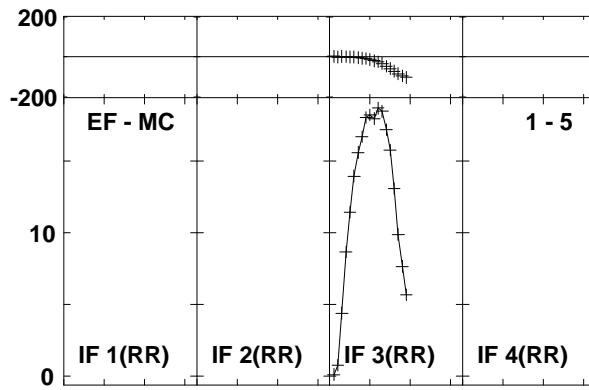
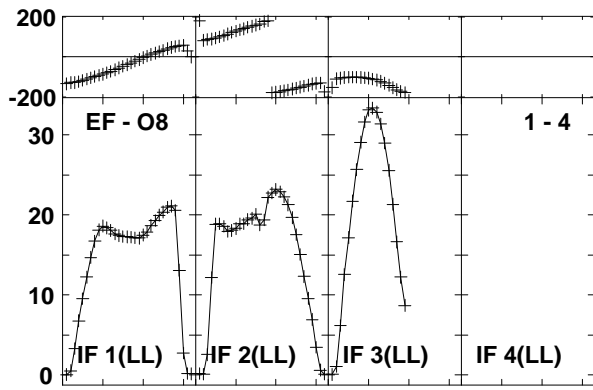
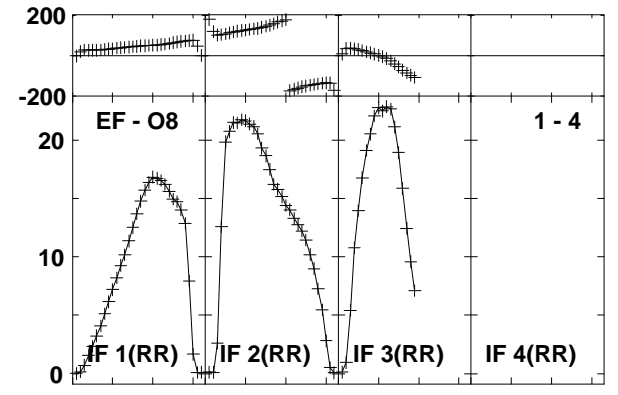
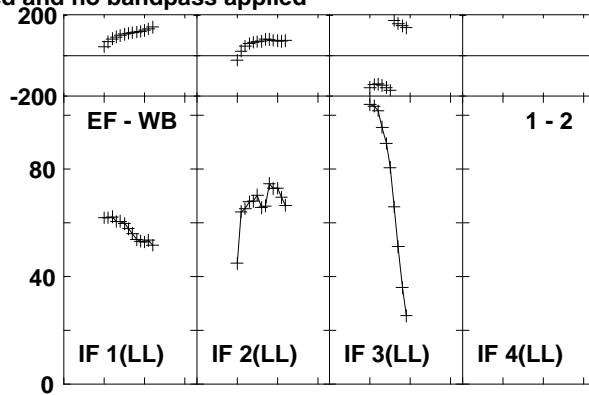
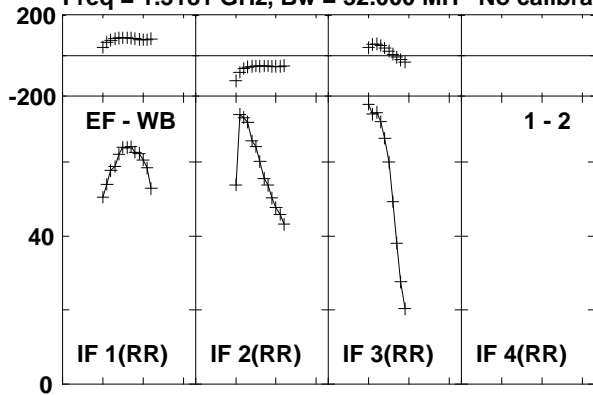

Lower frame: Milli Ampl Jy Top frame: Phas deg
Vector averaged cross-power spectrum Baseline: EF (01) - WB (02)
Timerange: 00/12:09:58 to 00/12:19:54

Plot file version 157 created 20-NOV-2015 13:44:01

DA193 EO013 1.UVDATA.1

Freq = 1.3181 GHz, Bw = 32.000 MH No calibration applied and no bandpass applied

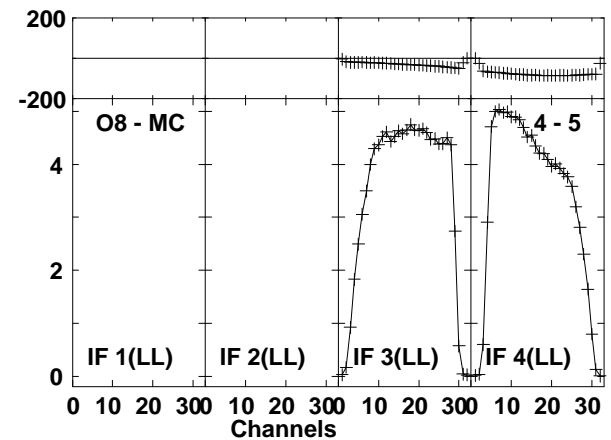
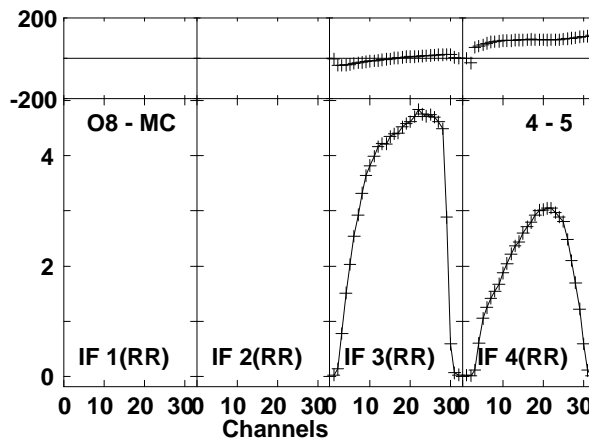
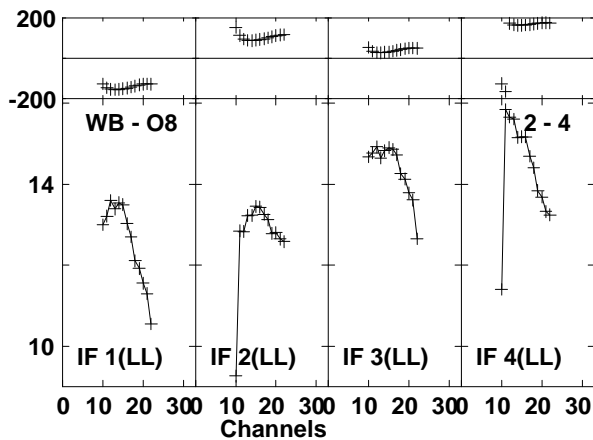
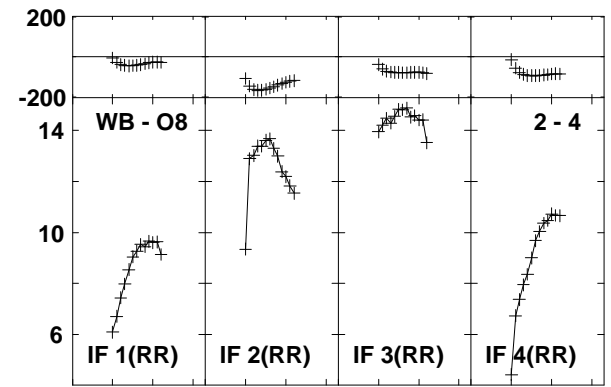
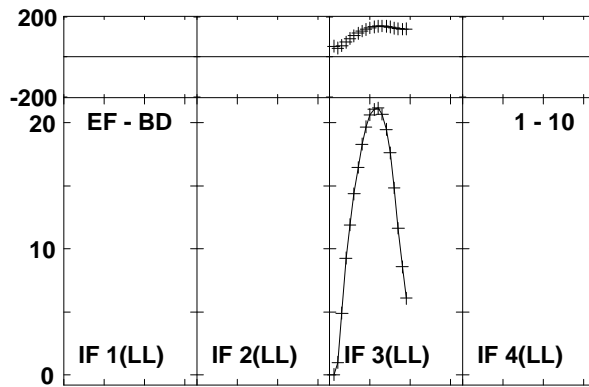
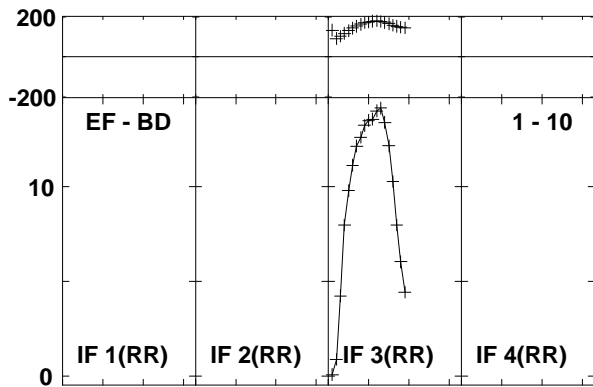
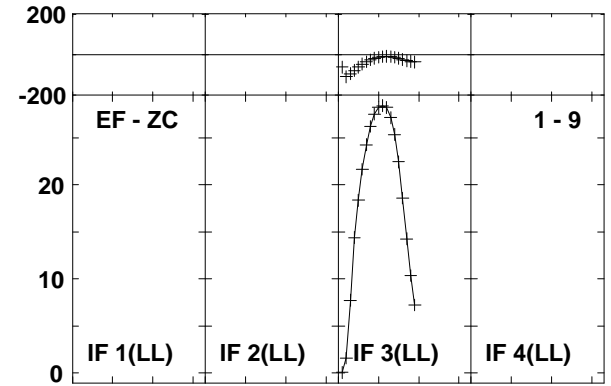
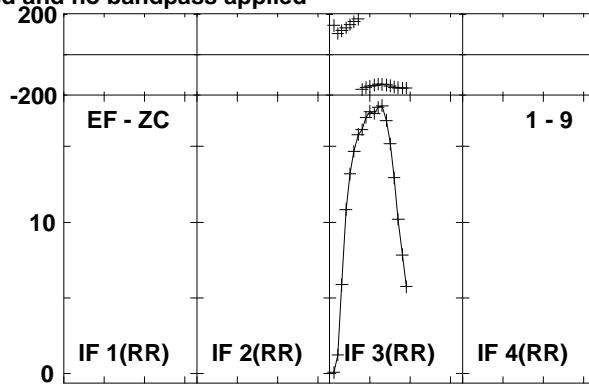
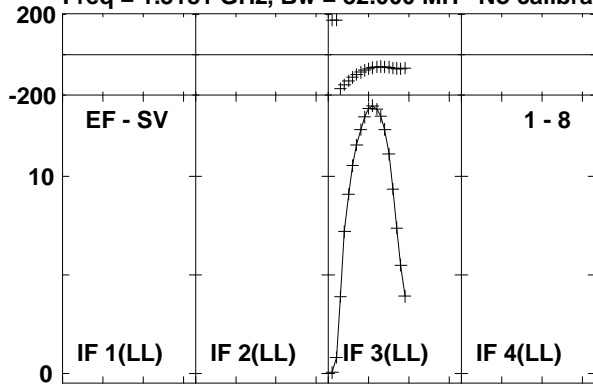

Lower frame: Milli Ampl Jy Top frame: Phas deg
Vector averaged cross-power spectrum Baseline: EF (01) - SV (08)
Timerange: 00/12:09:58 to 00/12:19:54

Plot file version 158 created 20-NOV-2015 13:44:01

DA193 EO013 1.UVDATA.1

Freq = 1.3181 GHz, Bw = 32.000 MHz No calibration applied and no bandpass applied

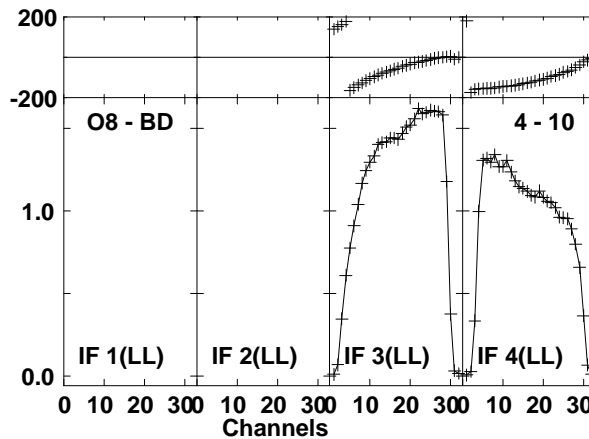
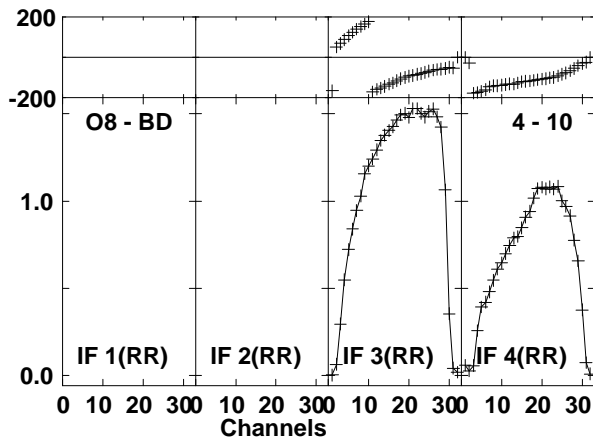
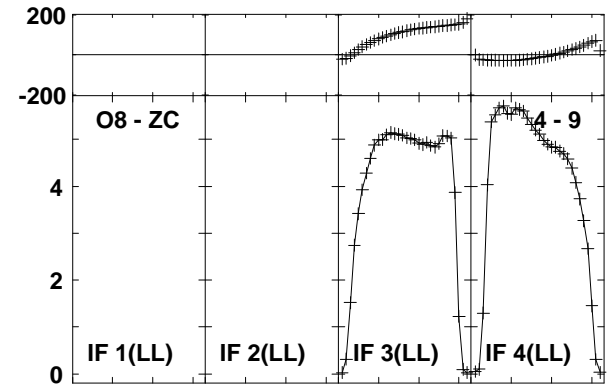
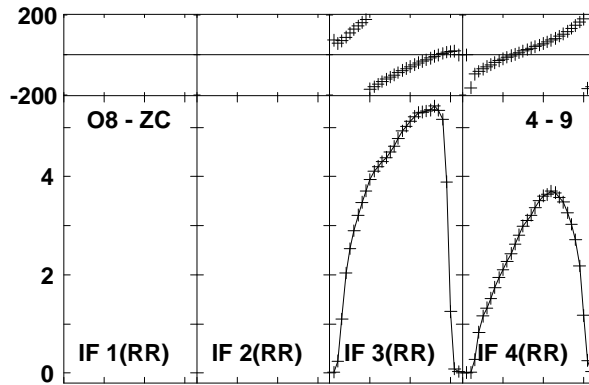
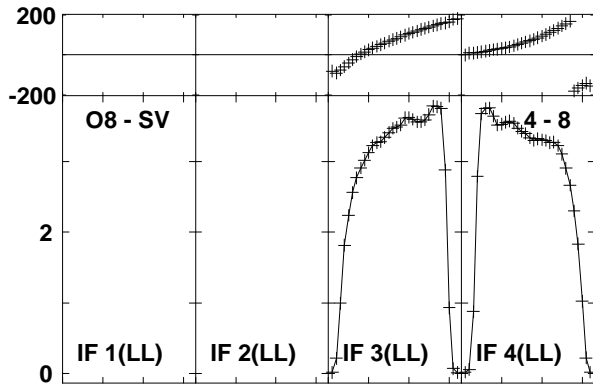
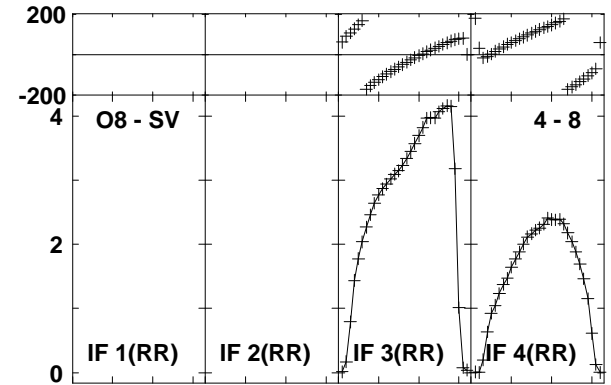
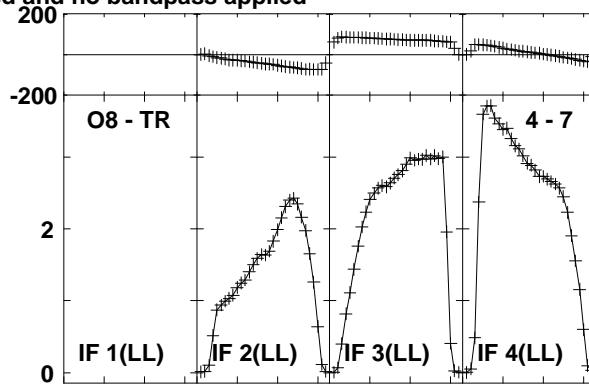
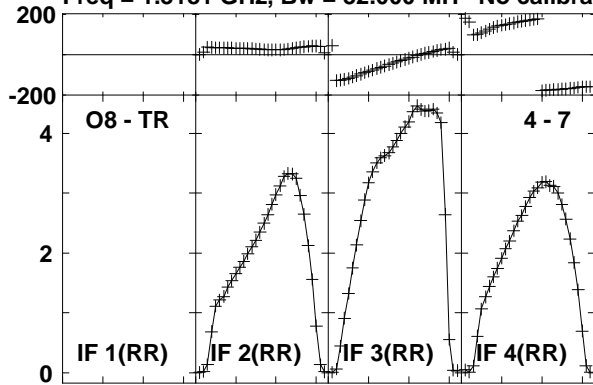

Lower frame: Milli Ampl Jy Top frame: Phas deg
Vector averaged cross-power spectrum Baseline: O8 (04) - TR (07)
Timerange: 00/12:09:58 to 00/12:19:54

Plot file version 159 created 20-NOV-2015 13:44:01

DA193 EO013 1.UVDATA.1

Freq = 1.3181 GHz, Bw = 32.000 MH No calibration applied and no bandpass applied

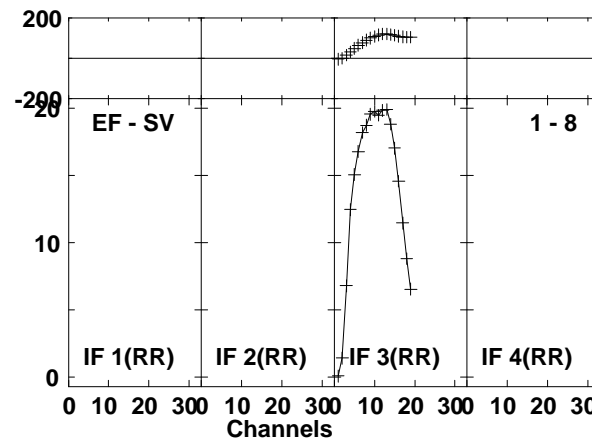
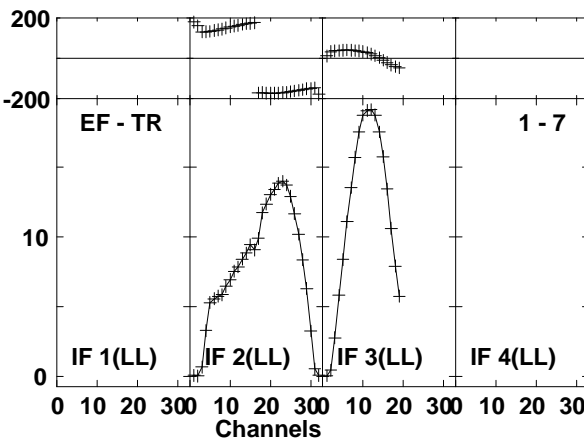
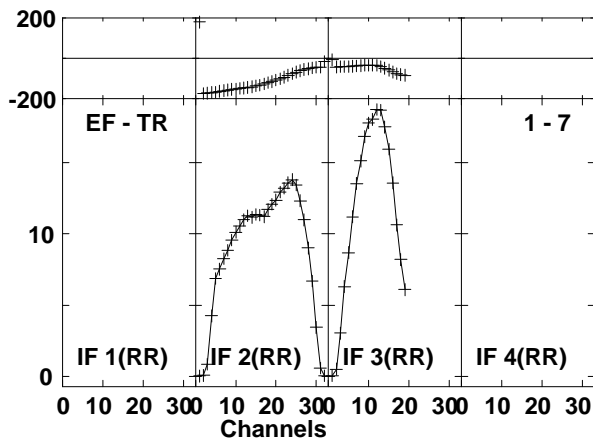
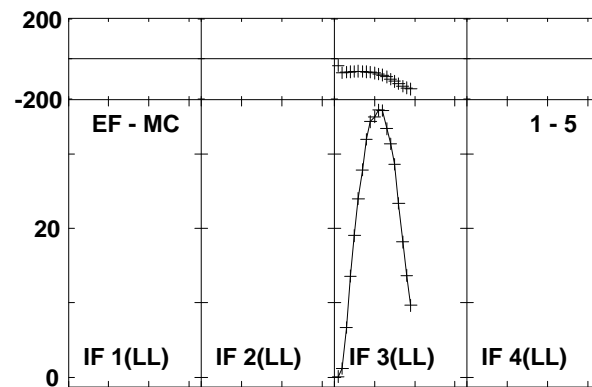
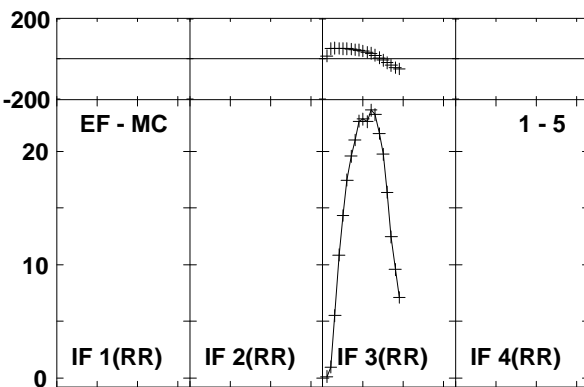
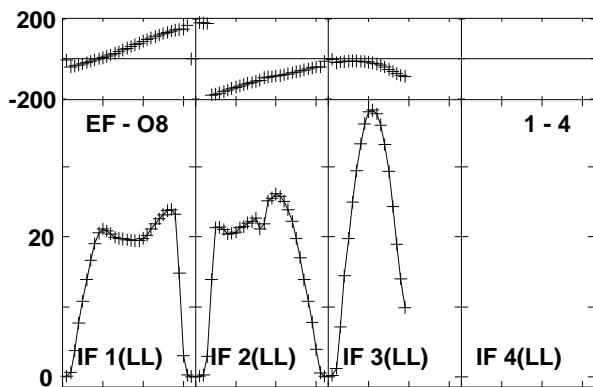
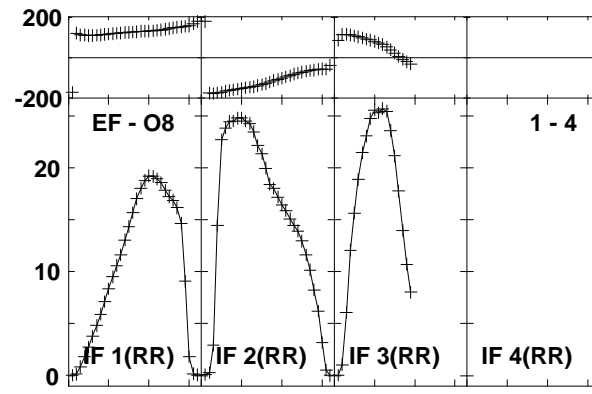
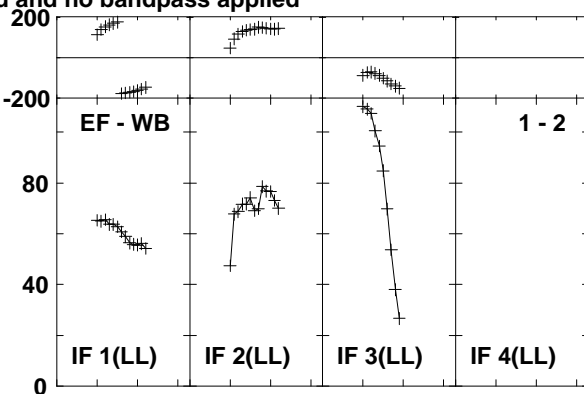
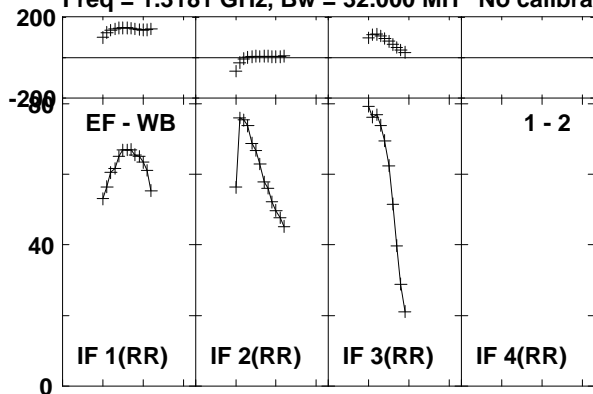

Lower frame: Milli Ampl Jy Top frame: Phas deg
Vector averaged cross-power spectrum Baseline: EF (01) - WB (02)
Timerange: 00/12:20:28 to 00/12:25:24

Plot file version 160 created 20-NOV-2015 13:44:01

DA193 EO013 1.UVDATA.1

Freq = 1.3181 GHz, Bw = 32.000 MH No calibration applied and no bandpass applied

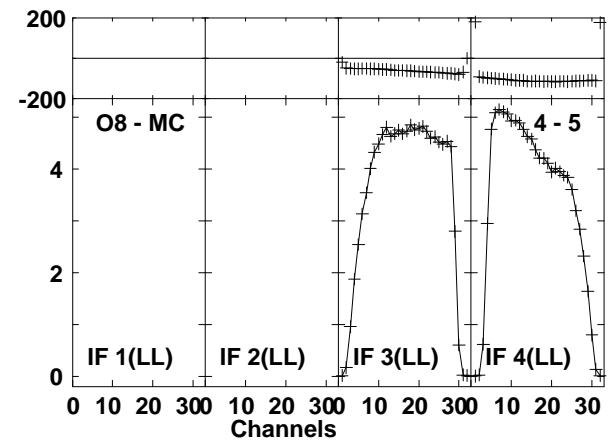
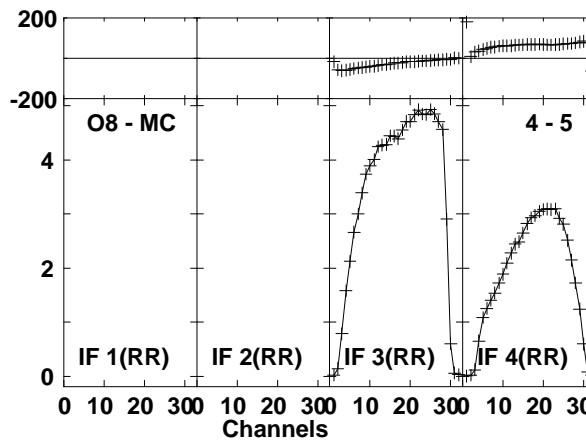
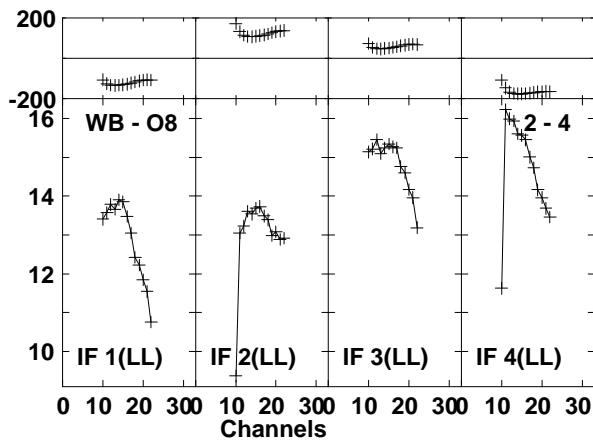
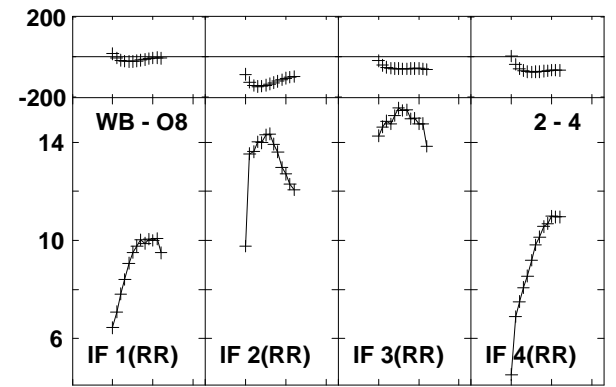
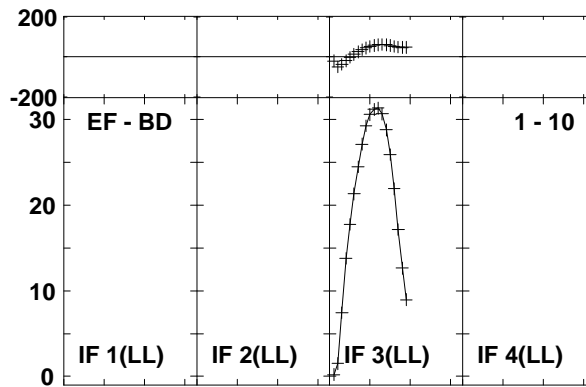
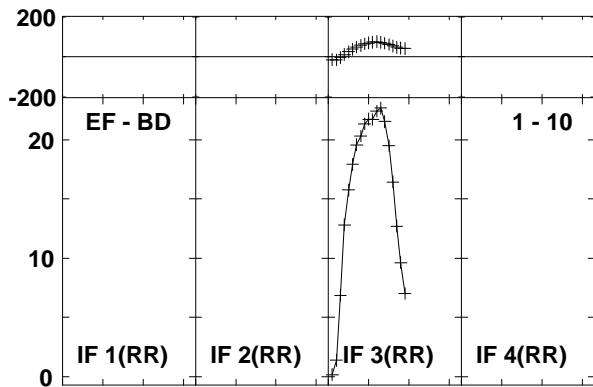
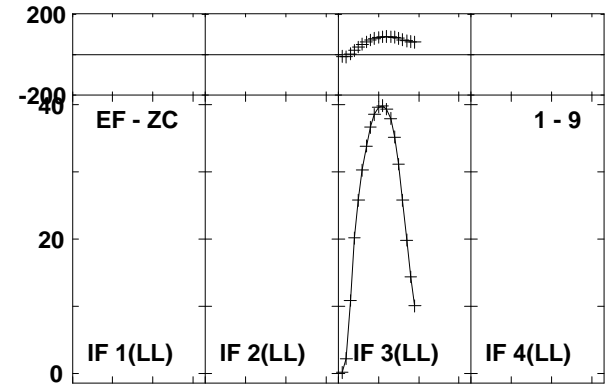
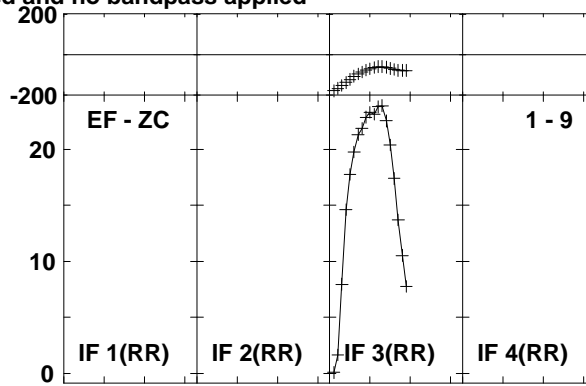
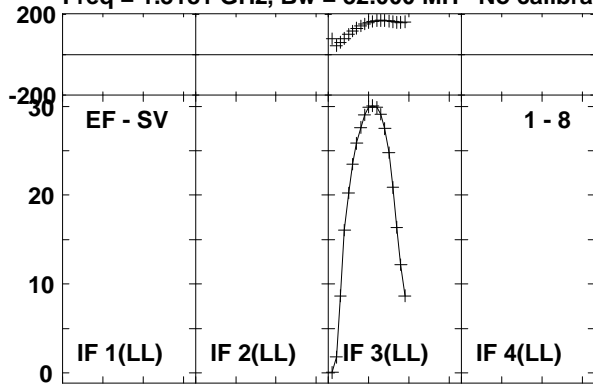

Lower frame: Milli Ampl Jy Top frame: Phas deg
Vector averaged cross-power spectrum Baseline: EF (01) - SV (08)
Timerange: 00/12:20:28 to 00/12:25:24

Plot file version 161 created 20-NOV-2015 13:44:01
 DA193 EO013 1.UVDATA.1
 Freq = 1.3181 GHz, Bw = 32.000 MH No calibration applied and no bandpass applied

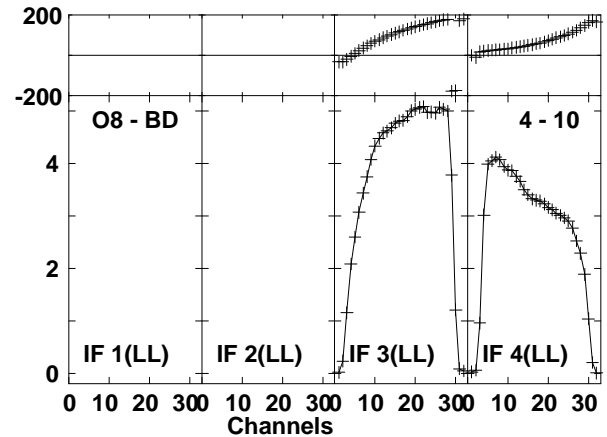
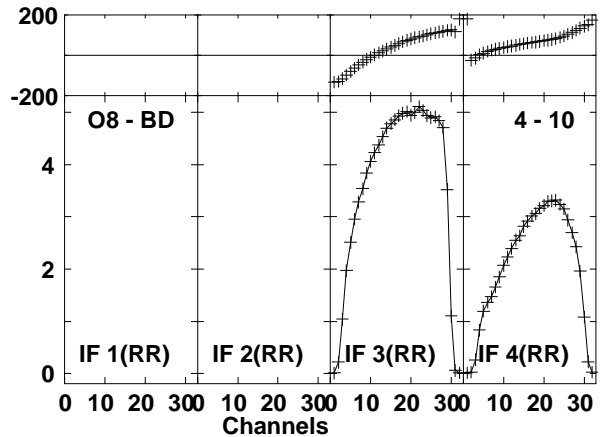
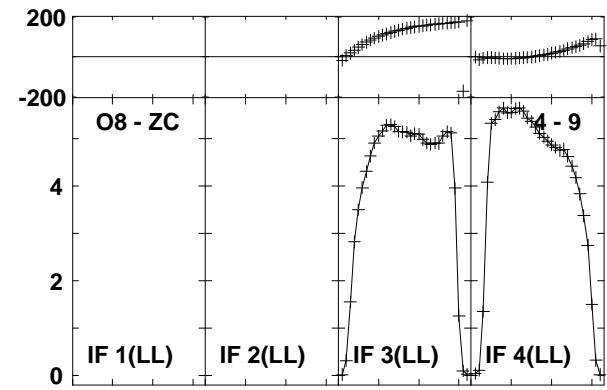
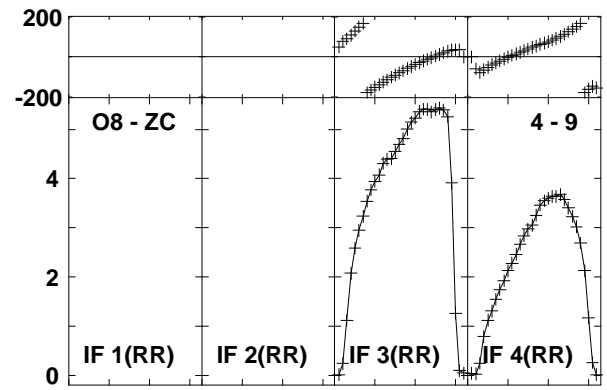
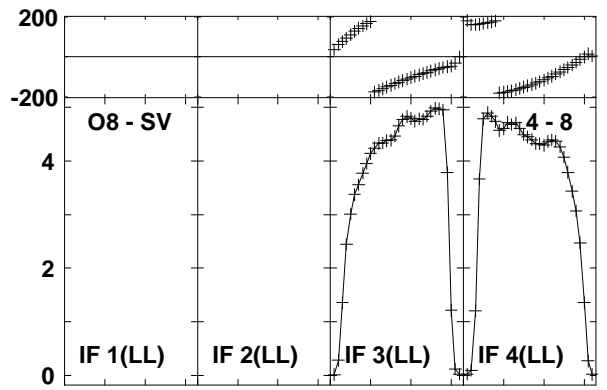
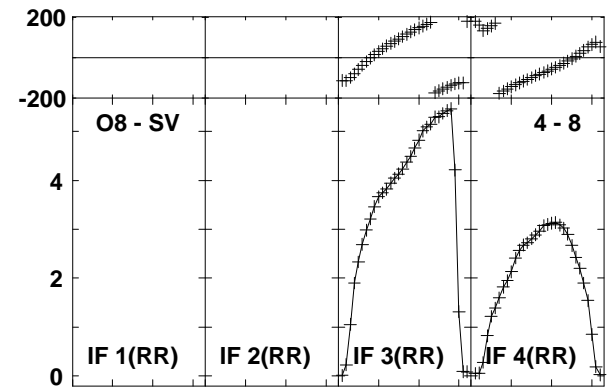
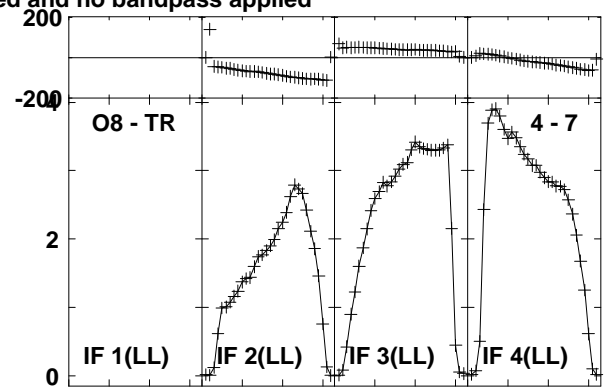
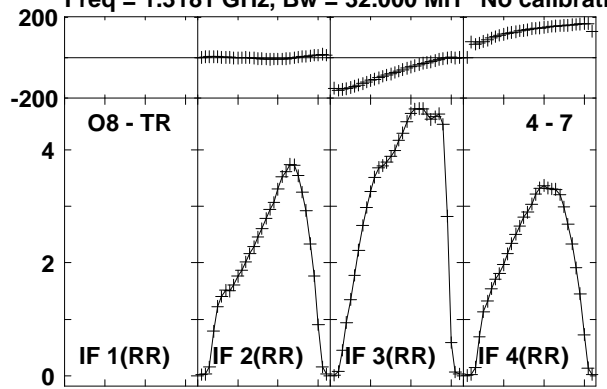

Lower frame: Milli Ampl Jy Top frame: Phas deg
 Vector averaged cross-power spectrum Baseline: O8 (04) - TR (07)
 Timerange: 00/12:20:28 to 00/12:25:24

Plot file version 162 created 20-NOV-2015 13:44:01

3C84 EO013 1.UVDATA.1

Freq = 1.3181 GHz, Bw = 32.000 MH No calibration applied and no bandpass applied

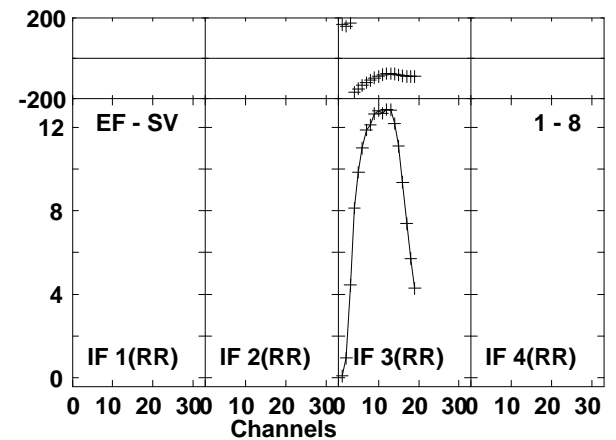
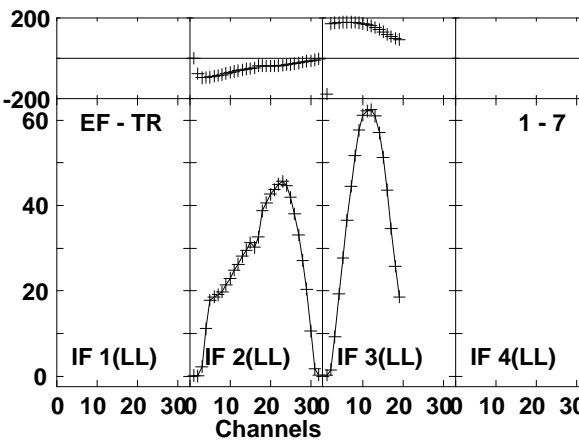
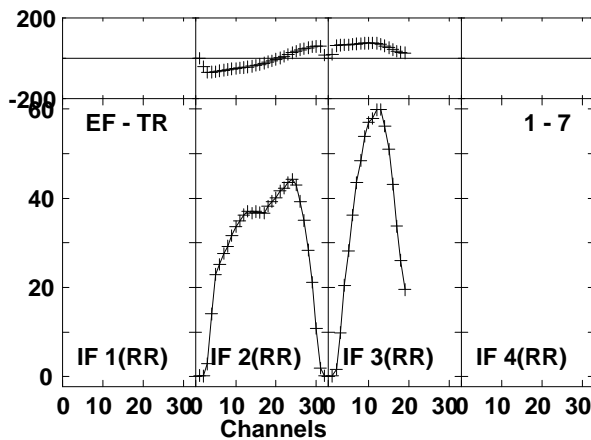
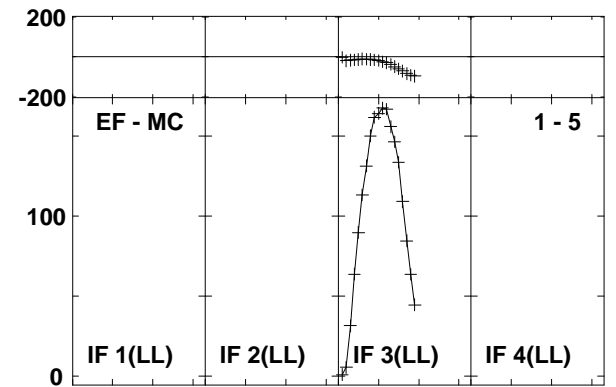
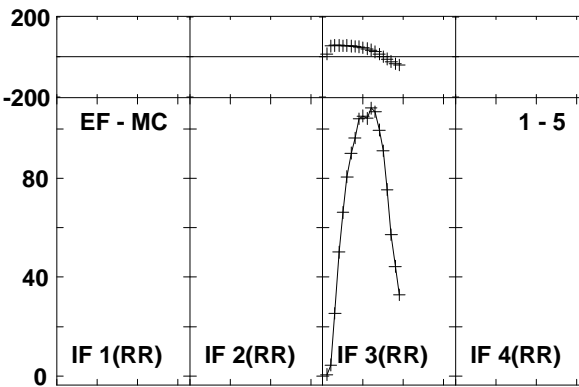
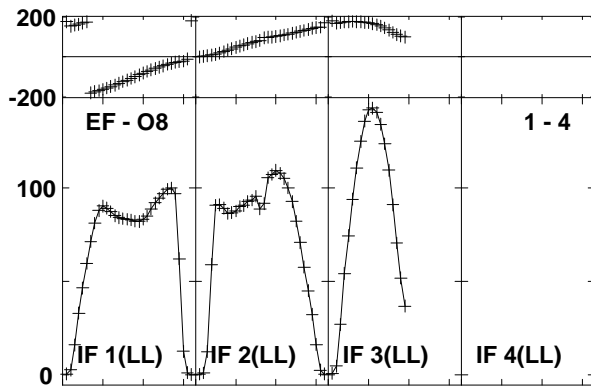
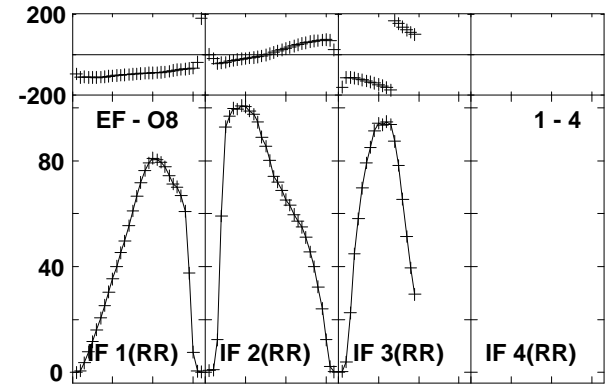
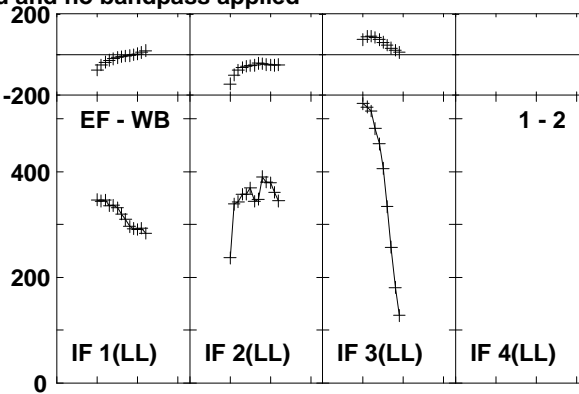
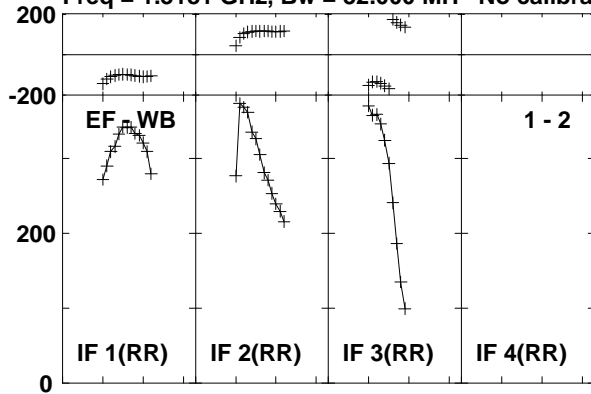

Lower frame: Milli Ampl Jy Top frame: Phas deg
Vector averaged cross-power spectrum Baseline: EF (01) - WB (02)
Timerange: 00/12:28:28 to 00/12:38:23

Plot file version 163 created 20-NOV-2015 13:44:01
 3C84 EO013 1.UVDATA.1
 Freq = 1.3181 GHz, Bw = 32.000 MH No calibration applied and no bandpass applied

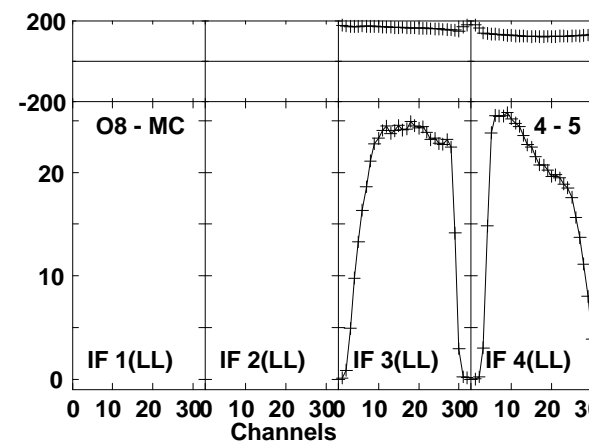
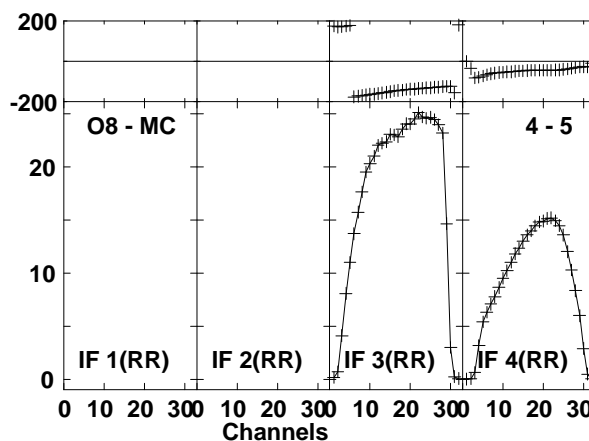
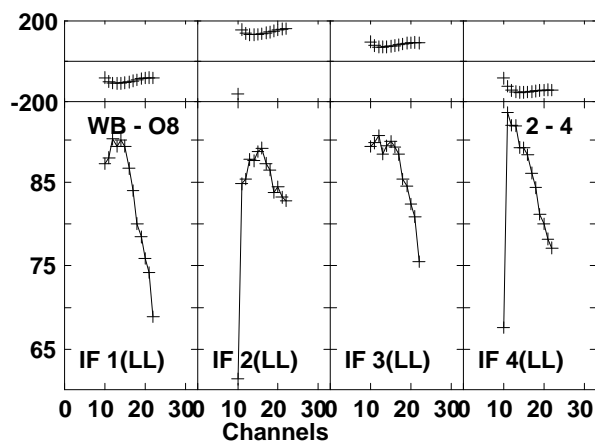
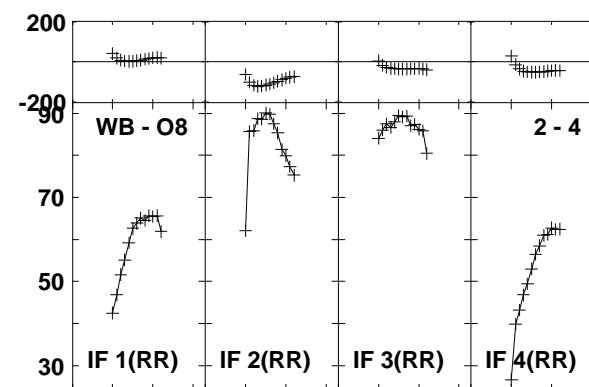
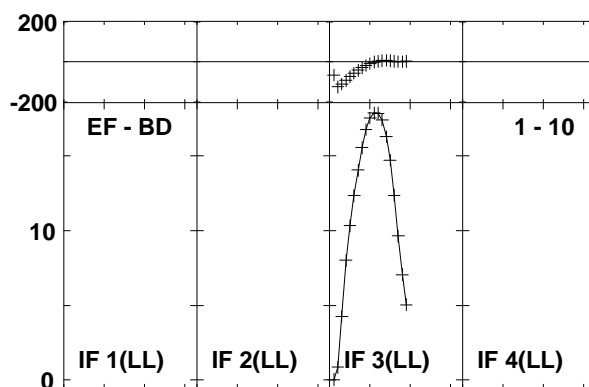
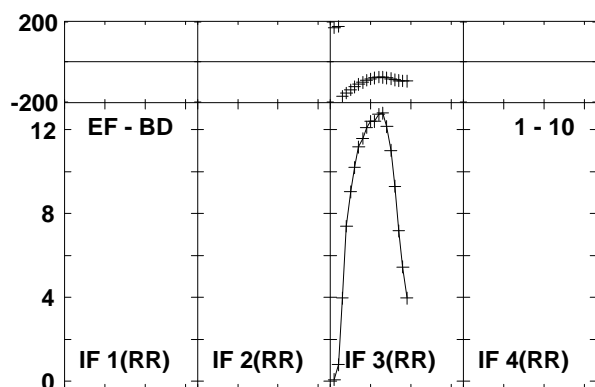
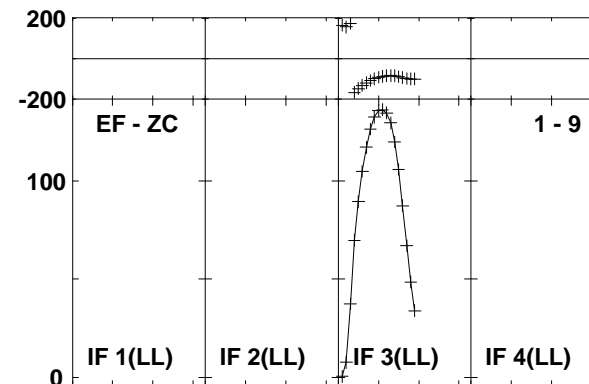
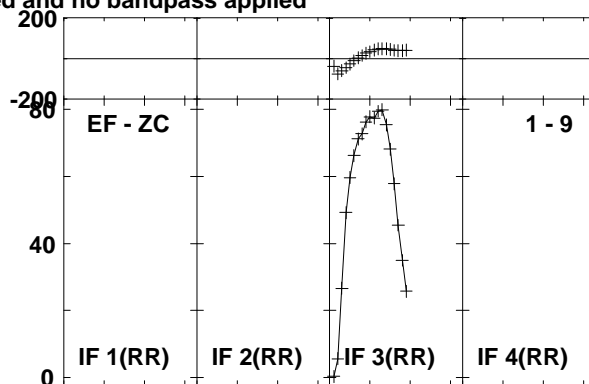
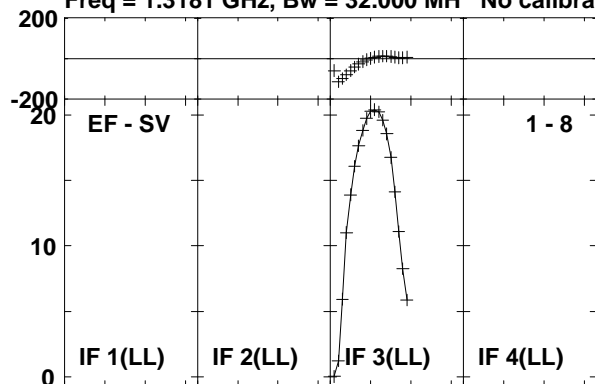

Lower frame: Milli Ampl Jy Top frame: Phas deg
 Vector averaged cross-power spectrum Baseline: EF (01) - SV (08)
 Timerange: 00/12:28:28 to 00/12:38:23

Plot file version 164 created 20-NOV-2015 13:44:01
 3C84 EO013 1.UVDATA.1
 Freq = 1.3181 GHz, Bw = 32.000 MH No calibration applied and no bandpass applied

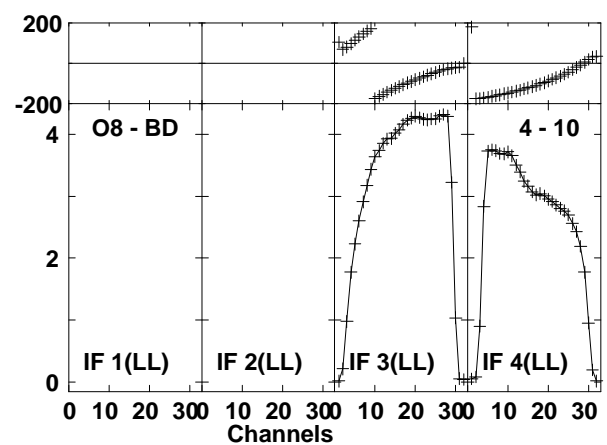
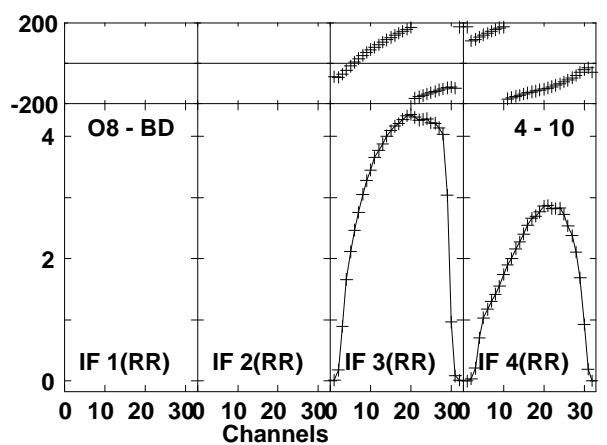
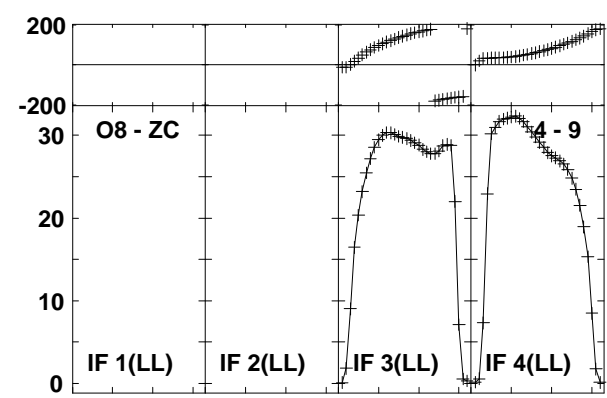
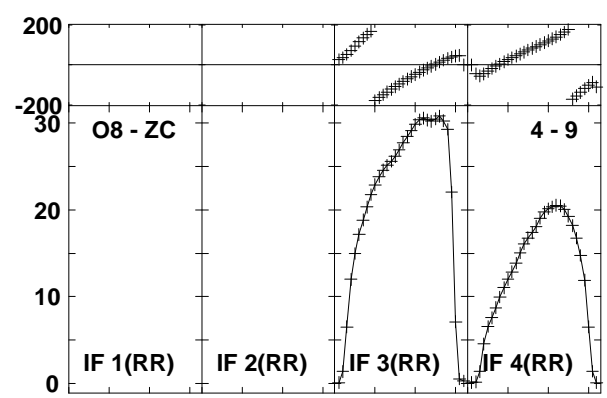
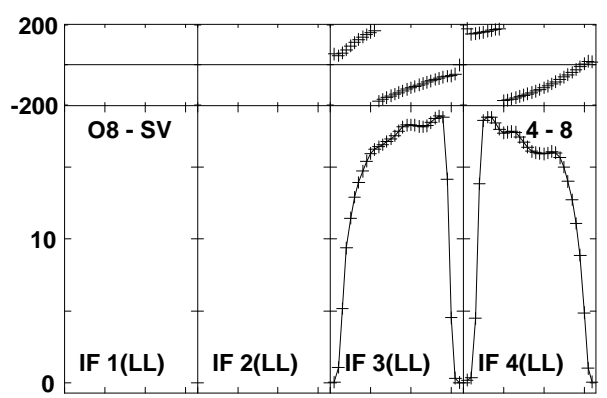
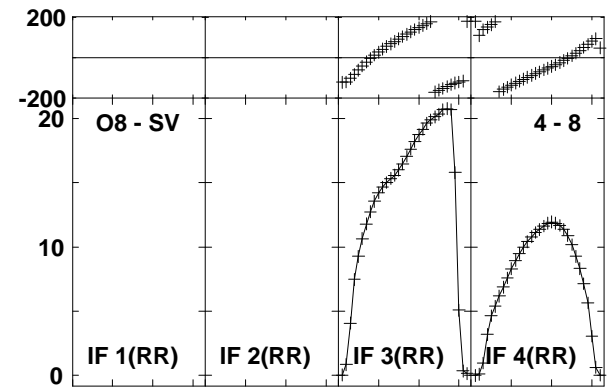
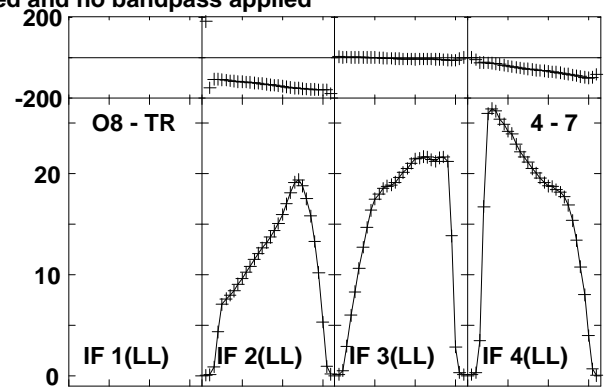
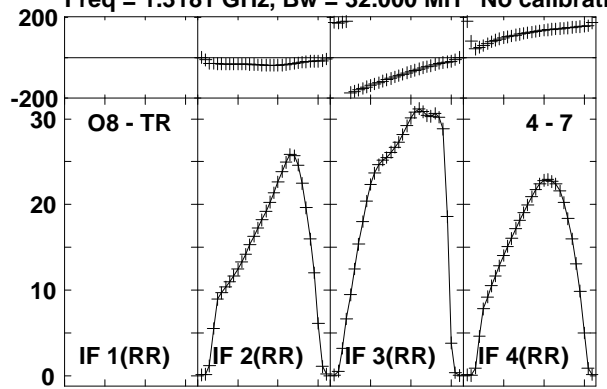

Lower frame: Milli Ampl Jy Top frame: Phas deg
 Vector averaged cross-power spectrum Baseline: O8 (04) - TR (07)
 Timerange: 00/12:28:28 to 00/12:38:23

Plot file version 165 created 20-NOV-2015 13:44:01

3C84 EO013 1.UVDATA.1

Freq = 1.3181 GHz, Bw = 32.000 MH No calibration applied and no bandpass applied

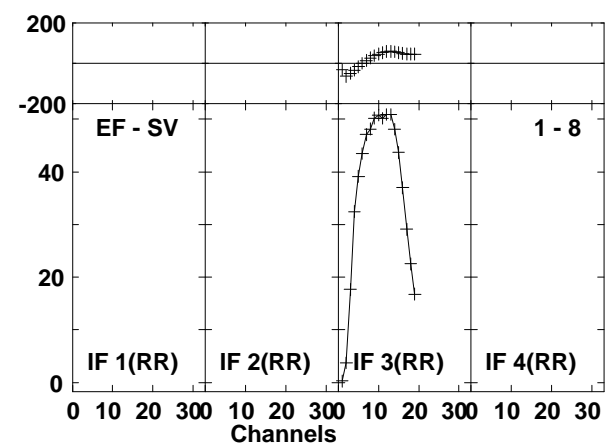
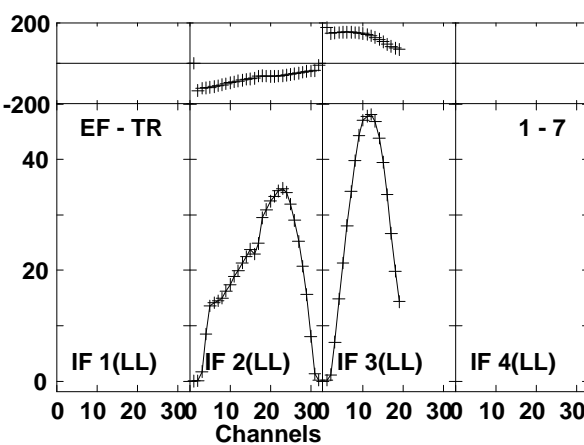
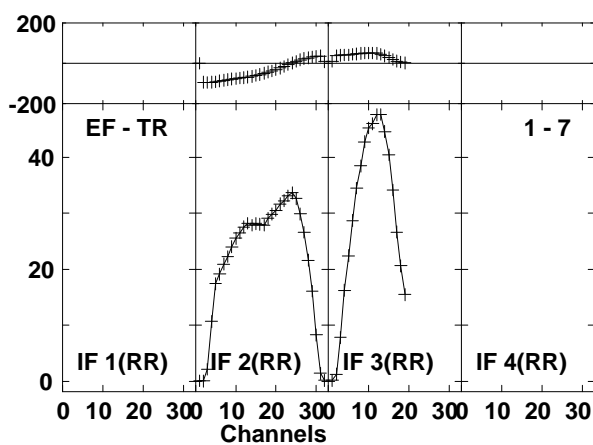
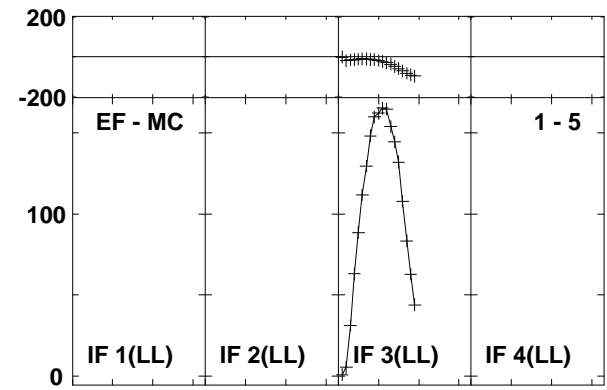
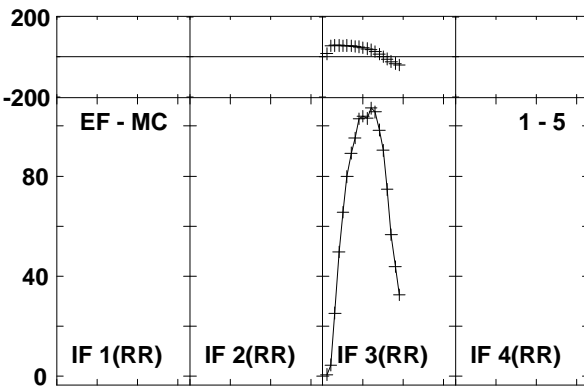
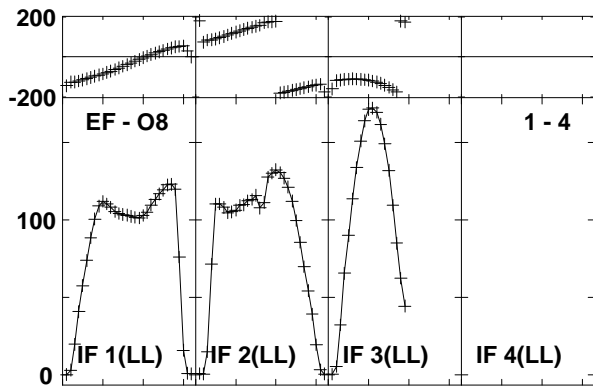
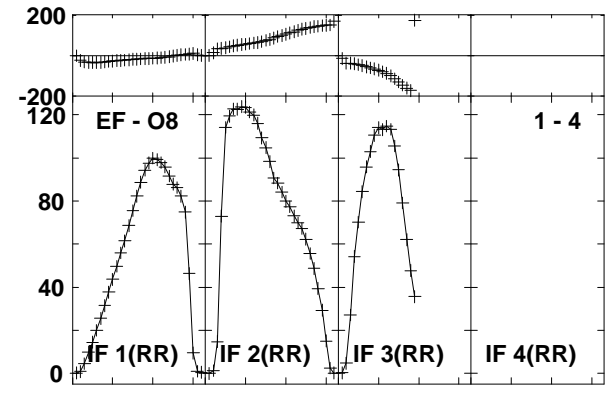
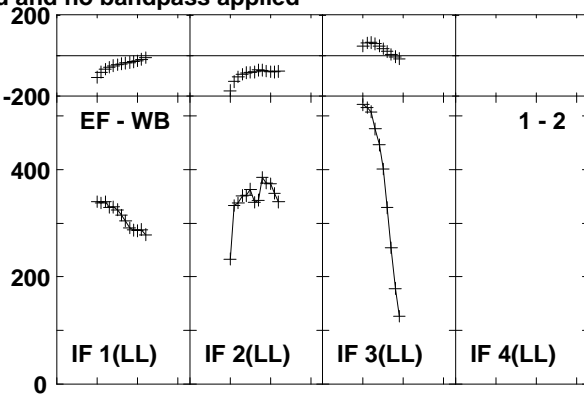
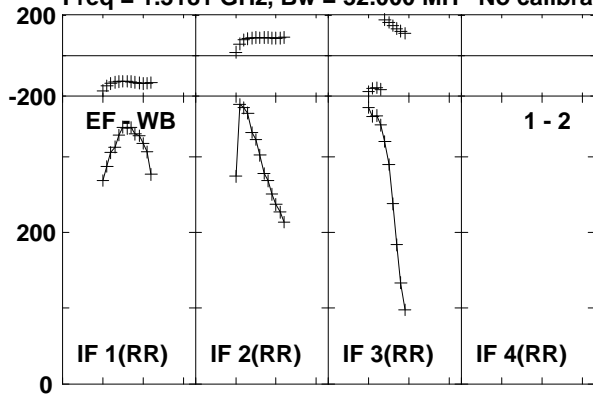

Lower frame: Milli Ampl Jy Top frame: Phas deg
Vector averaged cross-power spectrum Baseline: EF (01) - WB (02)
Timerange: 00/12:38:58 to 00/12:48:54

Plot file version 166 created 20-NOV-2015 13:44:02
 3C84 EO013 1.UVDATA.1
 Freq = 1.3181 GHz, Bw = 32.000 MH No calibration applied and no bandpass applied

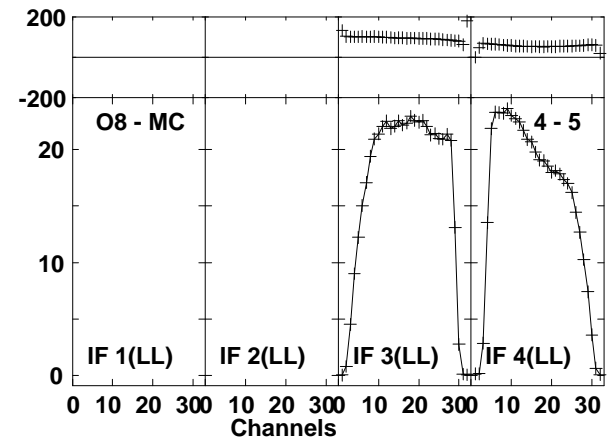
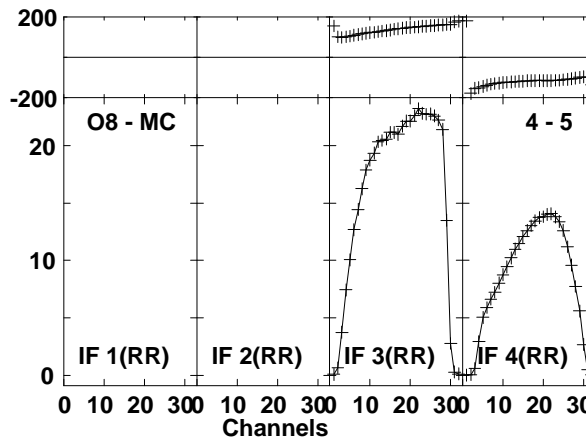
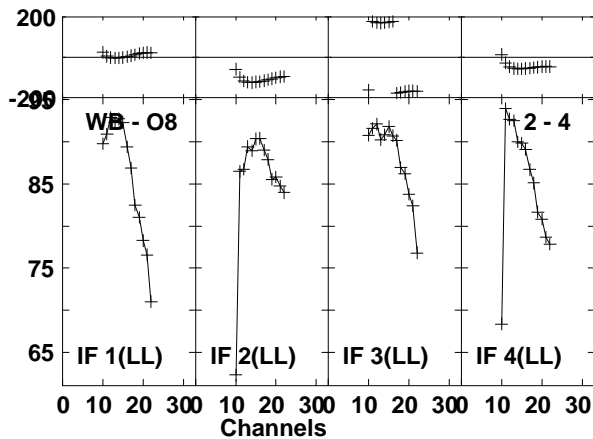
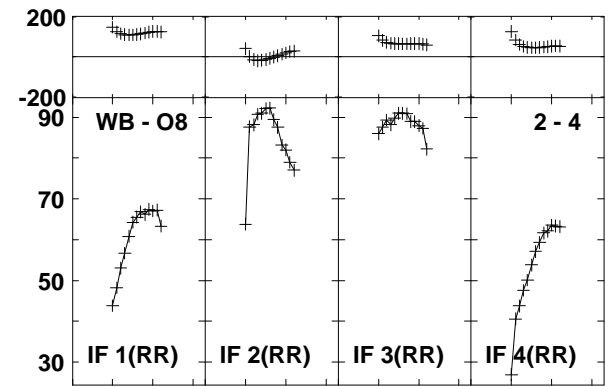
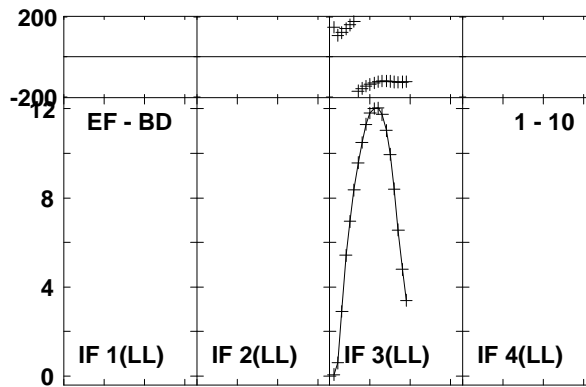
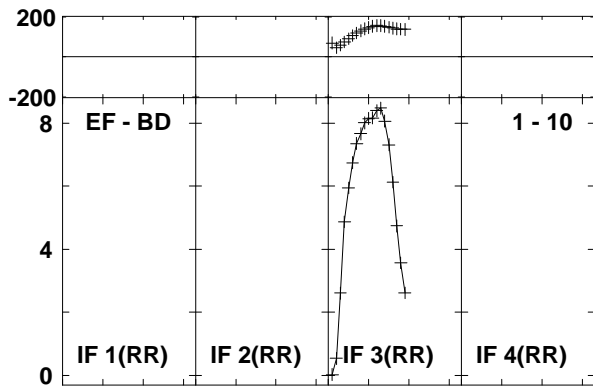
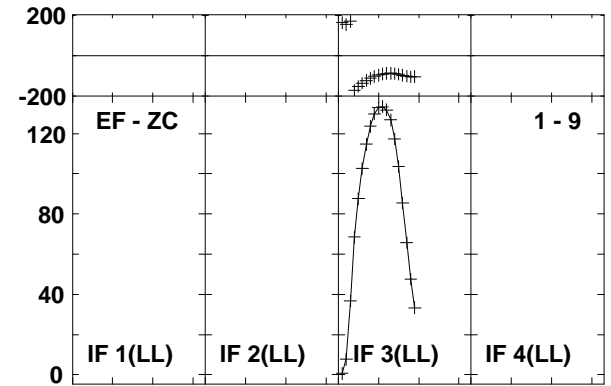
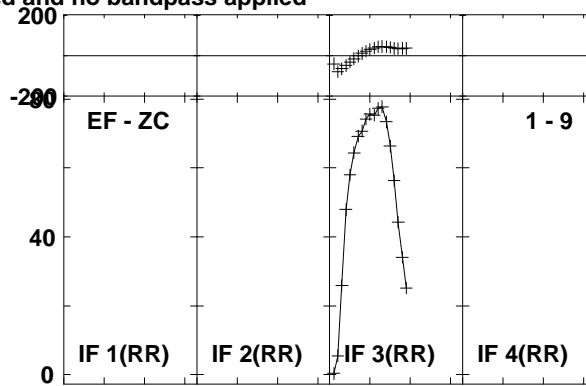
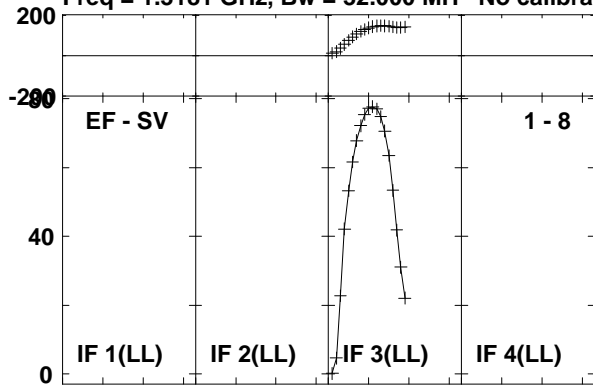

Lower frame: Milli Ampl Jy Top frame: Phas deg
 Vector averaged cross-power spectrum Baseline: EF (01) - SV (08)
 Timerange: 00/12:38:58 to 00/12:48:54

Plot file version 167 created 20-NOV-2015 13:44:02
 3C84 EO013 1.UVDATA.1
 Freq = 1.3181 GHz, Bw = 32.000 MH No calibration applied and no bandpass applied

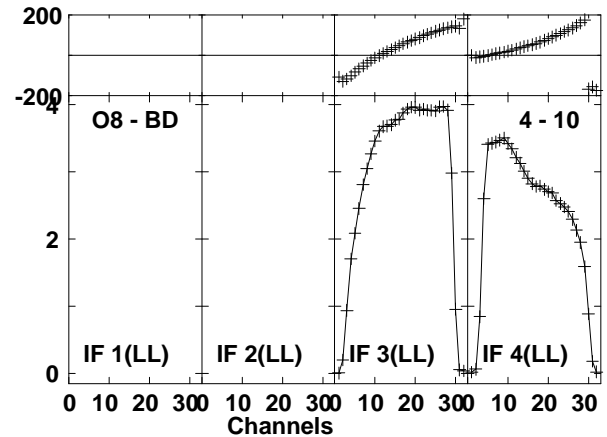
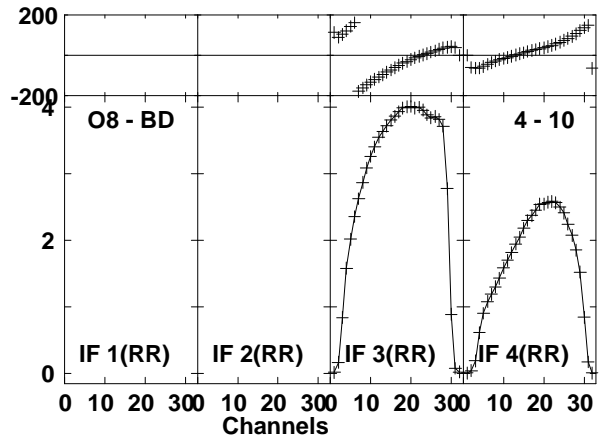
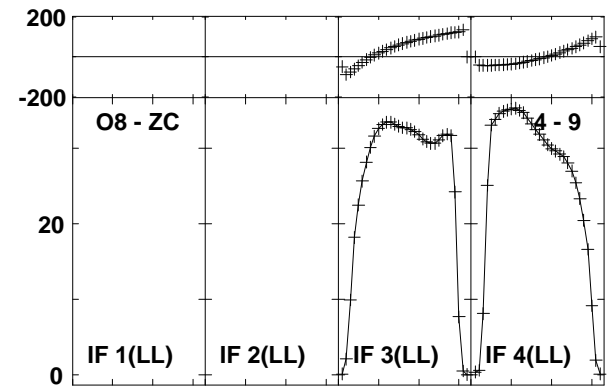
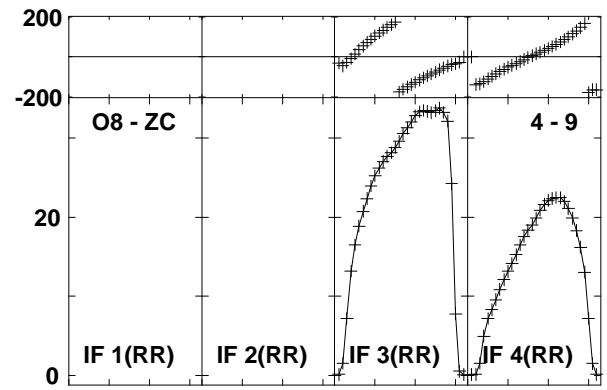
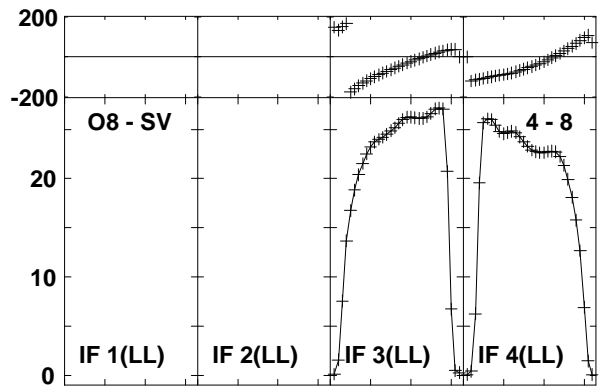
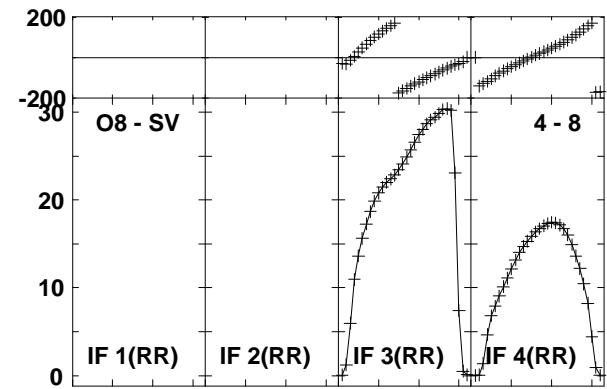
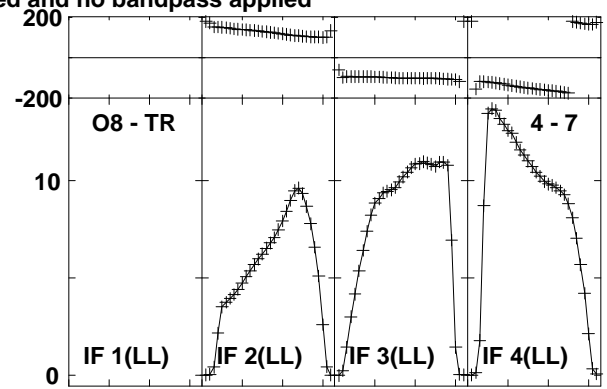
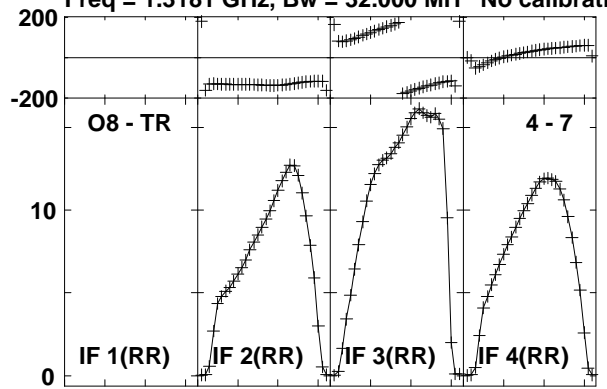

Lower frame: Milli Ampl Jy Top frame: Phas deg
 Vector averaged cross-power spectrum Baseline: O8 (04) - TR (07)
 Timerange: 00/12:38:58 to 00/12:48:54

Plot file version 168 created 20-NOV-2015 13:44:02
 3C84 EO013 1.UVDATA.1

Freq = 1.3181 GHz, Bw = 32.000 MH No calibration applied and no bandpass applied

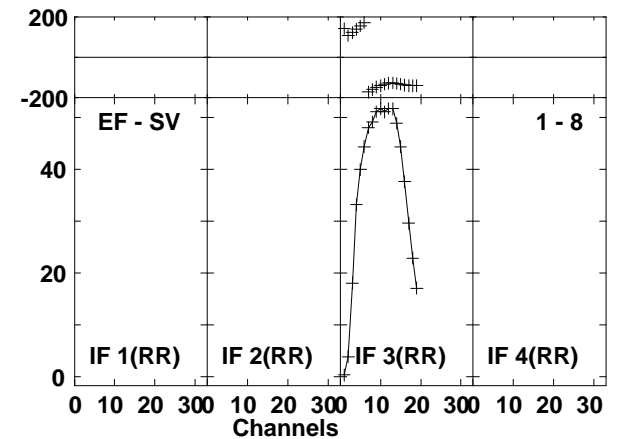
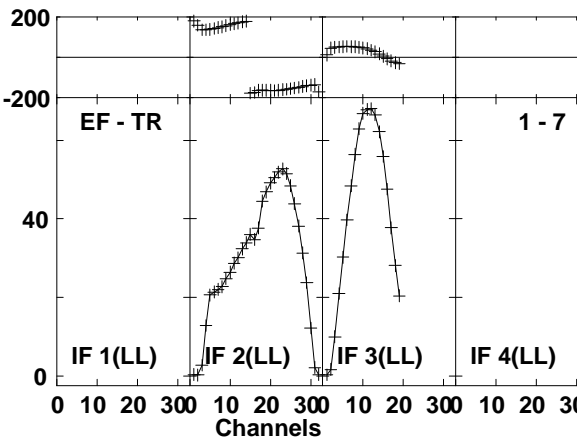
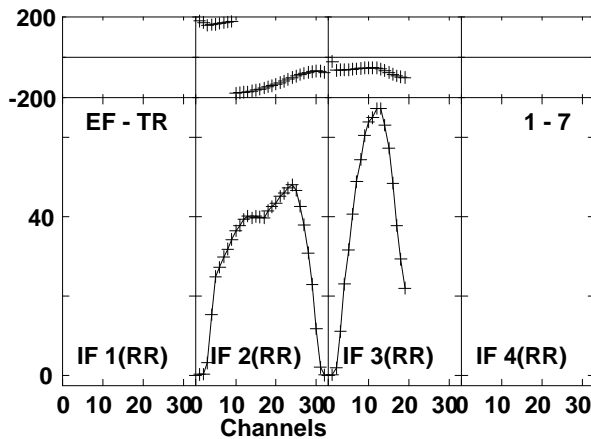
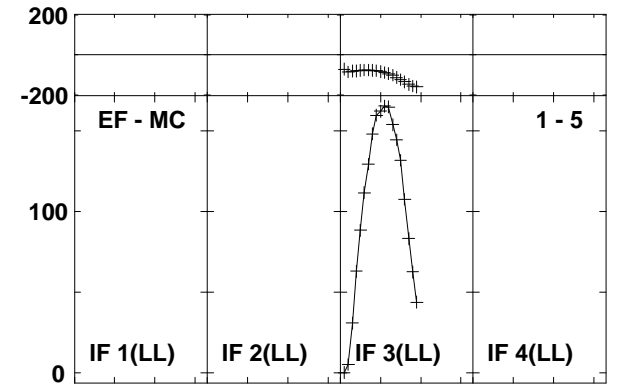
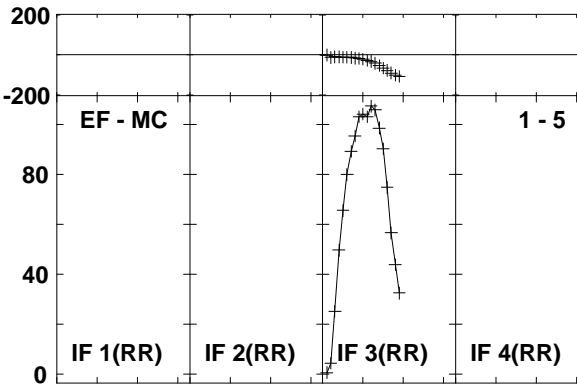
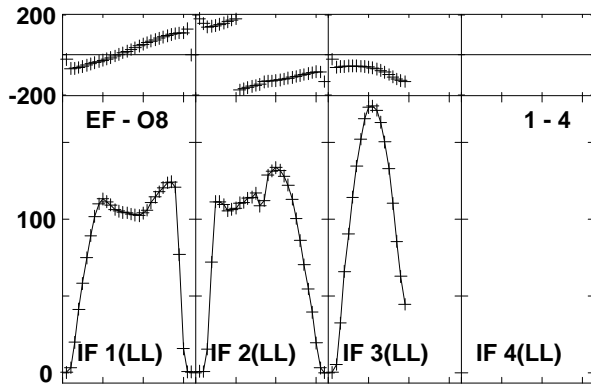
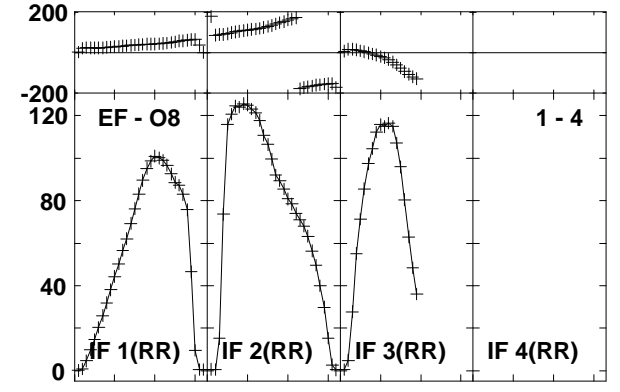
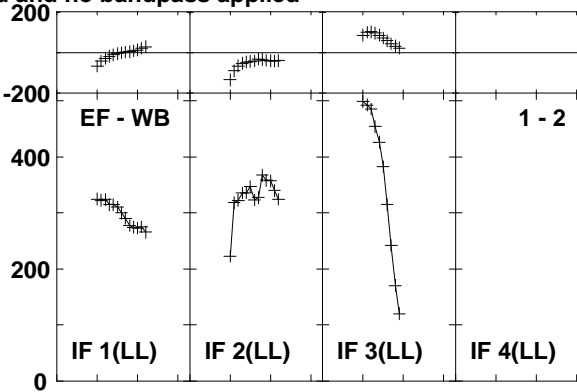
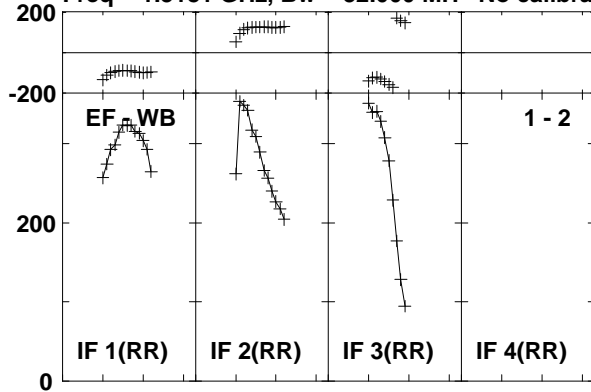

Lower frame: Milli Ampl Jy Top frame: Phas deg
 Vector averaged cross-power spectrum Baseline: EF (01) - WB (02)
 Timerange: 00/12:49:28 to 00/12:59:24

Plot file version 169 created 20-NOV-2015 13:44:02
 3C84 EO013 1.UVDATA.1
 Freq = 1.3181 GHz, Bw = 32.000 MH No calibration applied and no bandpass applied

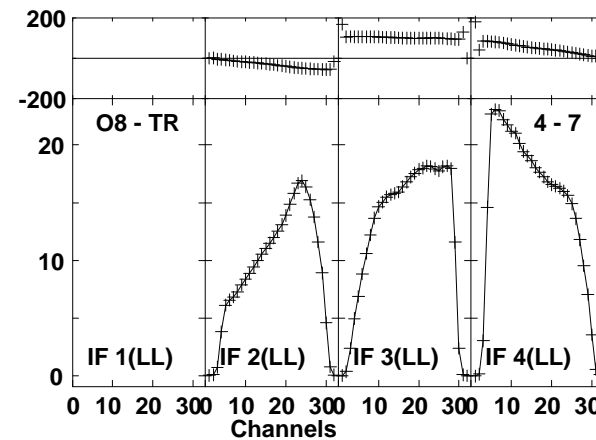
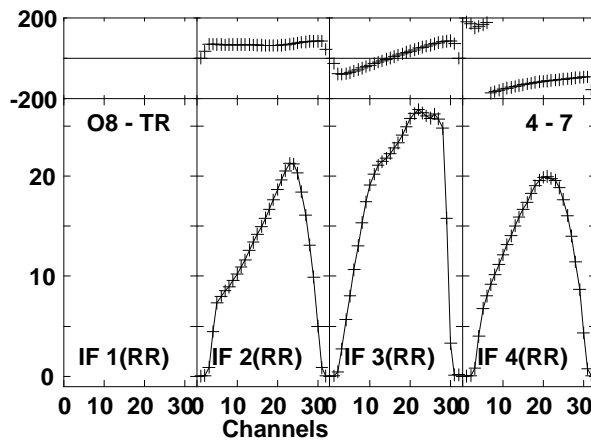
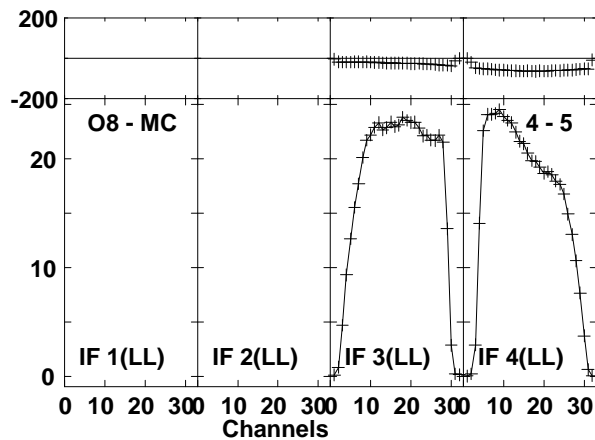
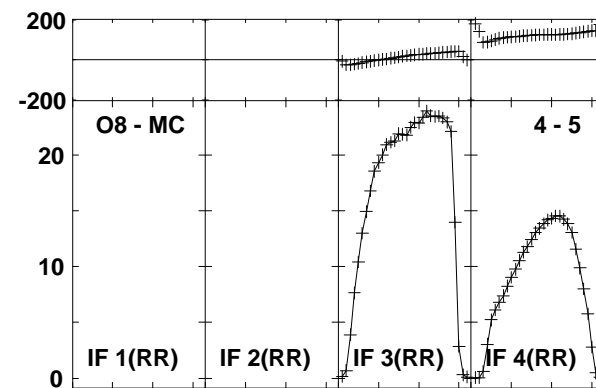
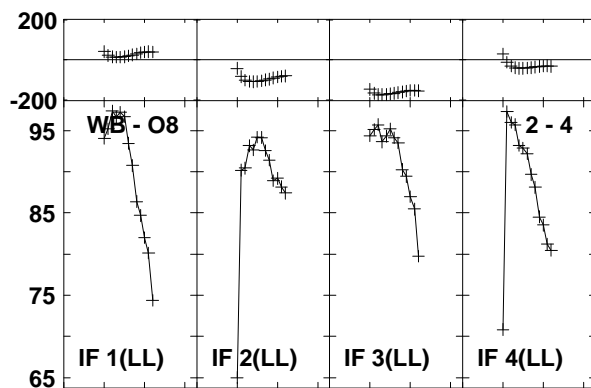
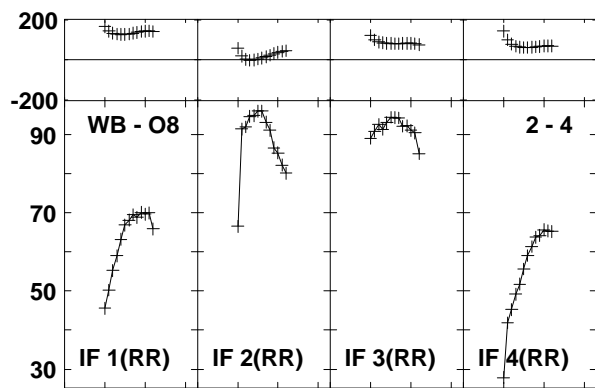
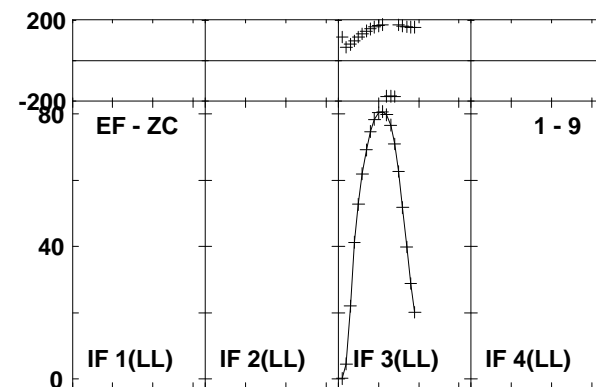
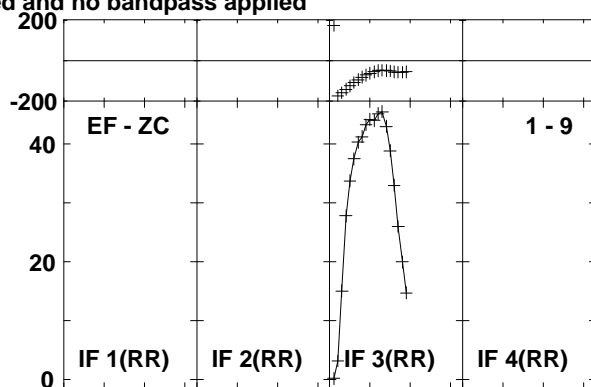
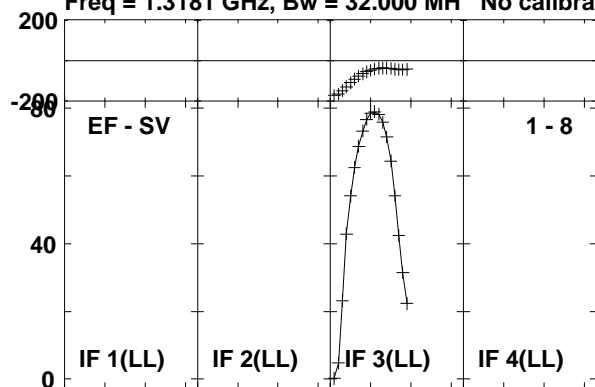

Lower frame: Milli Ampl Jy Top frame: Phas deg
 Vector averaged cross-power spectrum Baseline: EF (01) - SV (08)
 Timerange: 00/12:49:28 to 00/12:59:24

Plot file version 170 created 20-NOV-2015 13:44:02
 3C84 EO013 1.UVDATA.1
 Freq = 1.3181 GHz, Bw = 32.000 MH No calibration applied and no bandpass applied

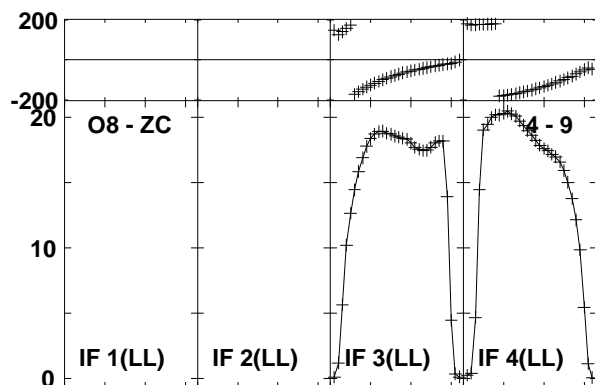
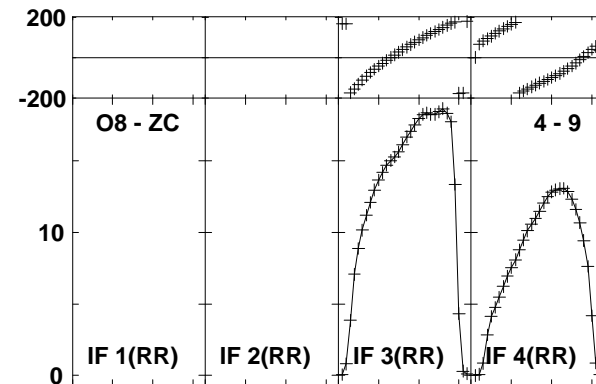
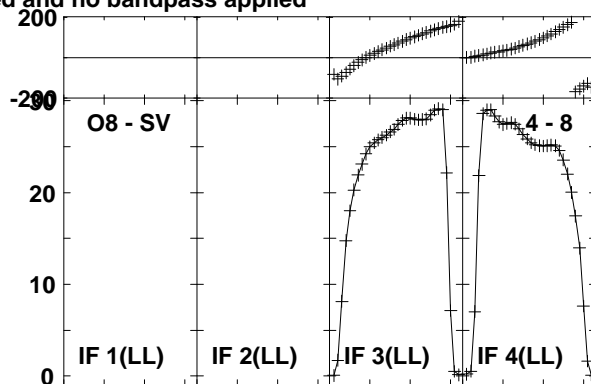
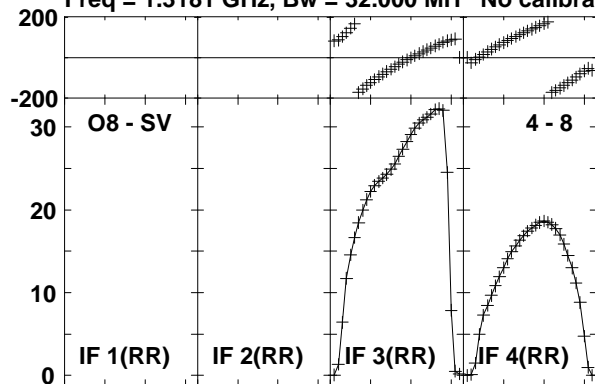

Lower frame: Milli Ampl Jy Top frame: Phas deg
 Vector averaged cross-power spectrum Baseline: O8 (04) - SV (08)
 Timerange: 00/12:49:28 to 00/12:59:24

Plot file version 171 created 20-NOV-2015 13:44:02

3C84 EO013 1.UVDATA.1

Freq = 1.3181 GHz, Bw = 32.000 MH No calibration applied and no bandpass applied

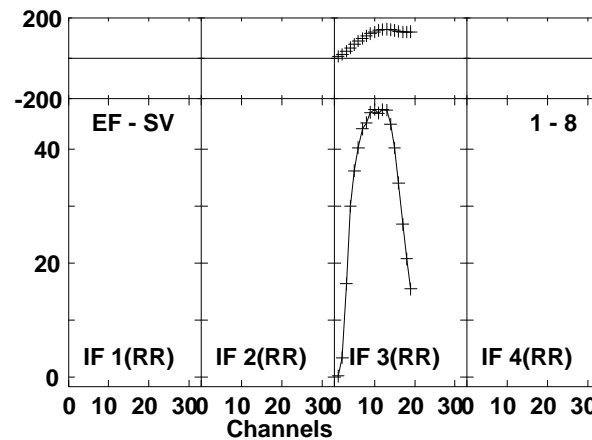
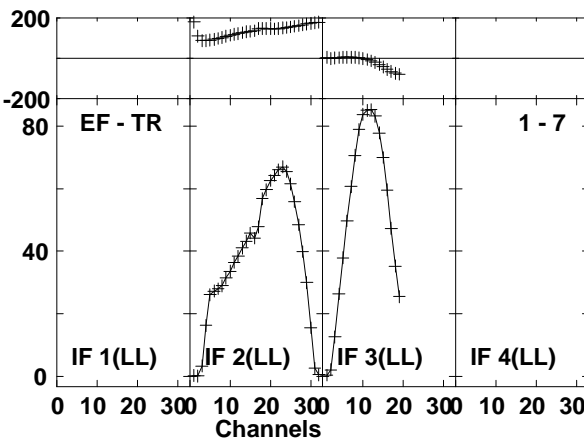
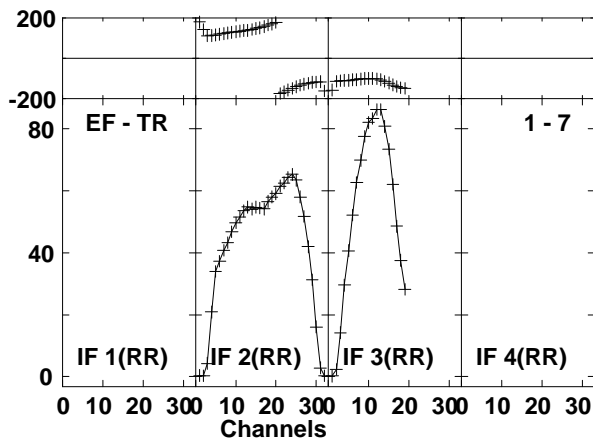
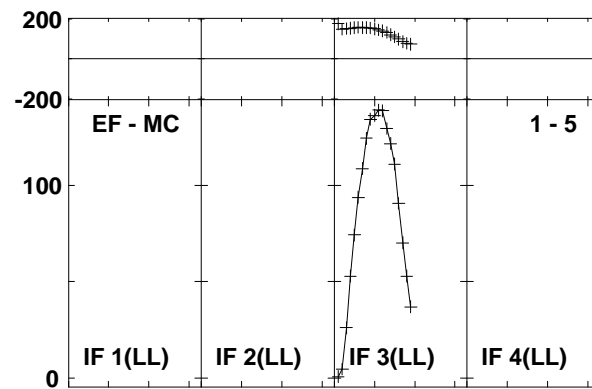
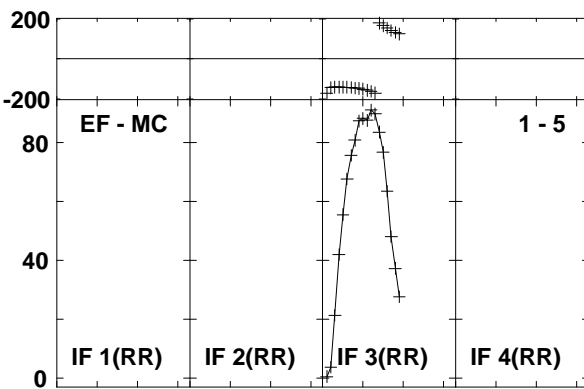
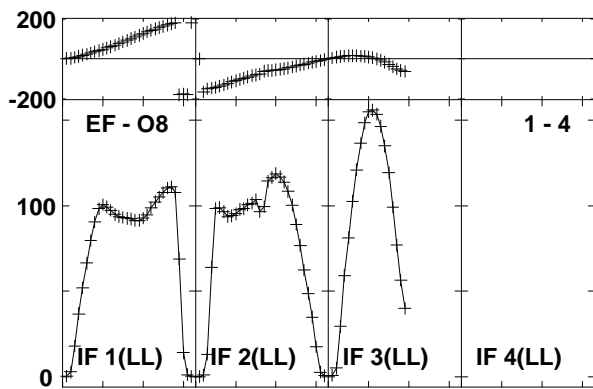
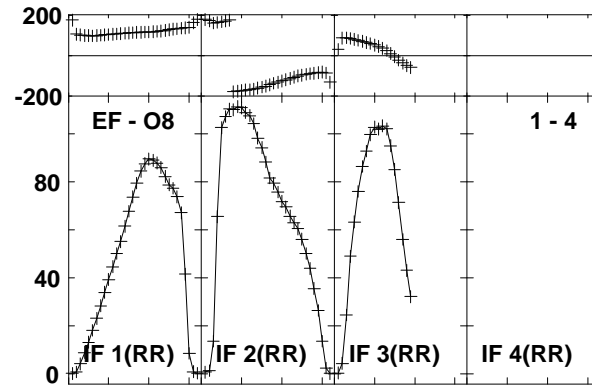
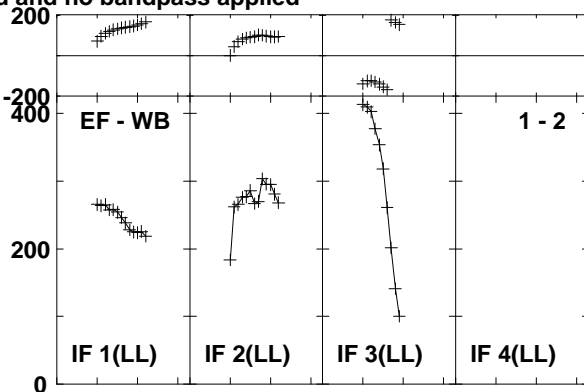
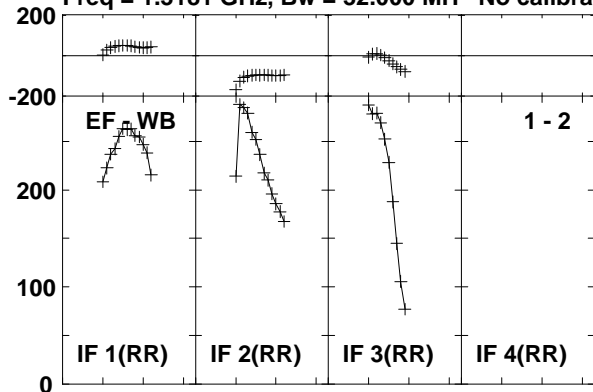

Lower frame: Milli Ampl Jy Top frame: Phas deg
Vector averaged cross-power spectrum Baseline: EF (01) - WB (02)
Timerange: 00/12:59:58 to 00/13:09:54

Plot file version 172 created 20-NOV-2015 13:44:02
 3C84 EO013 1.UVDATA.1
 Freq = 1.3181 GHz, Bw = 32.000 MH No calibration applied and no bandpass applied

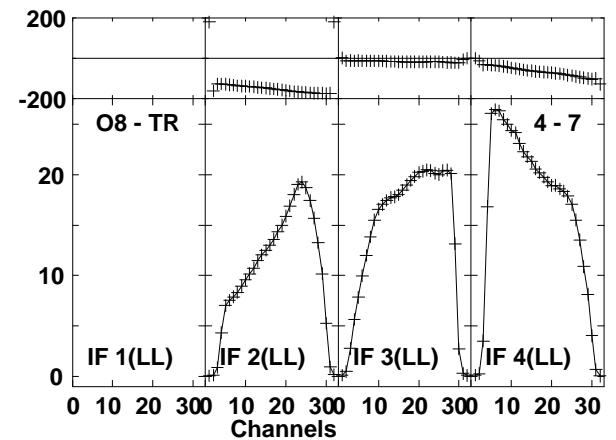
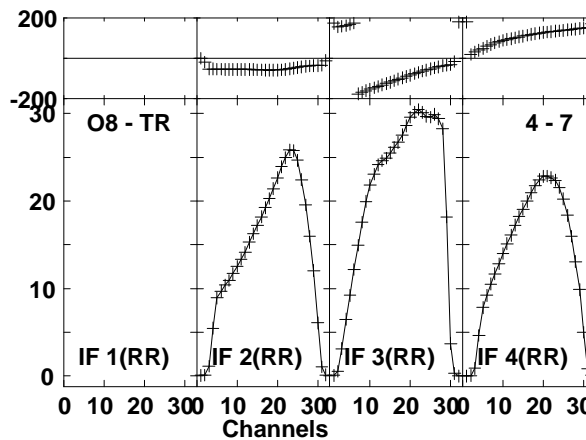
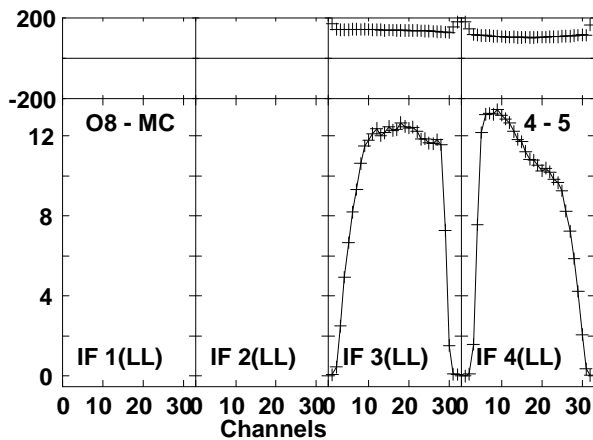
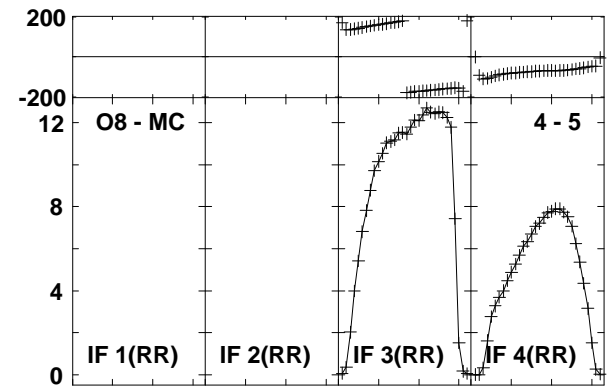
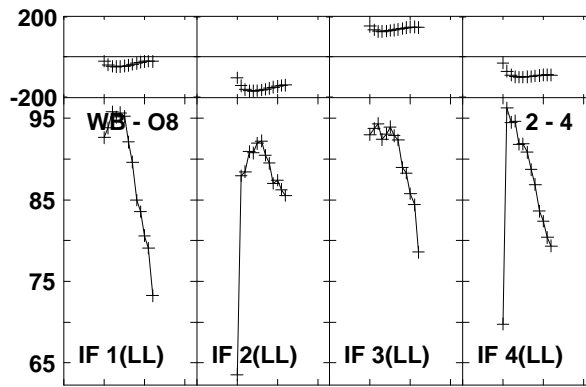
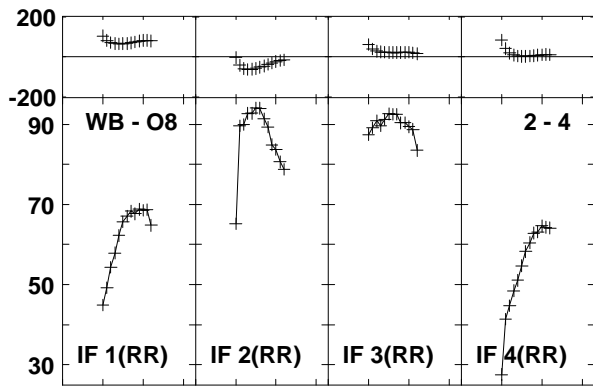
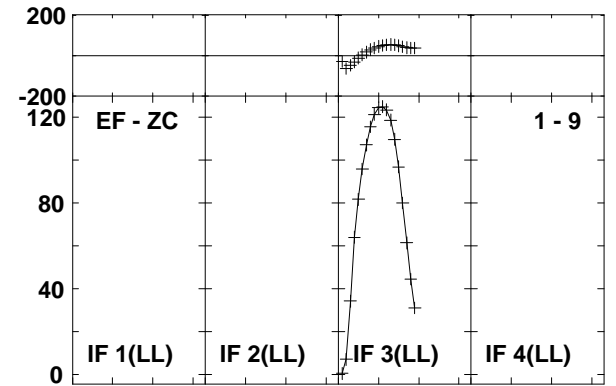
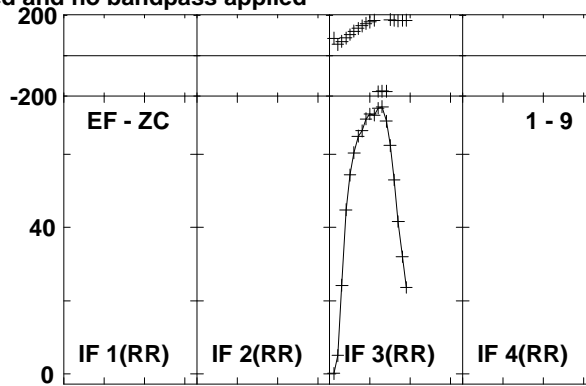
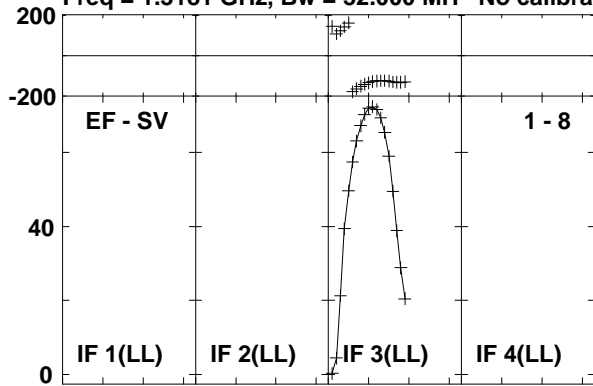

Lower frame: Milli Ampl Jy Top frame: Phas deg
 Vector averaged cross-power spectrum Baseline: EF (01) - SV (08)
 Timerange: 00/12:59:58 to 00/13:09:54

Plot file version 173 created 20-NOV-2015 13:44:02

3C84 EO013 1.UVDATA.1

Freq = 1.3181 GHz, Bw = 32.000 MH No calibration applied and no bandpass applied

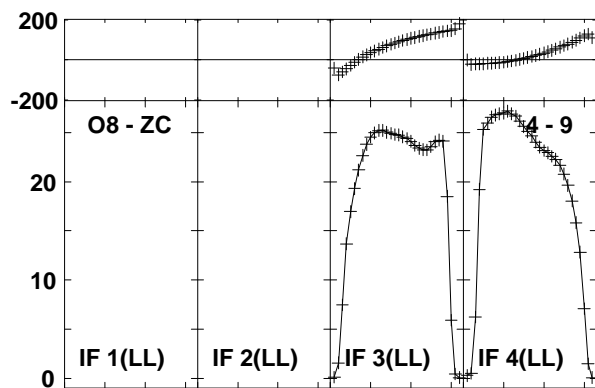
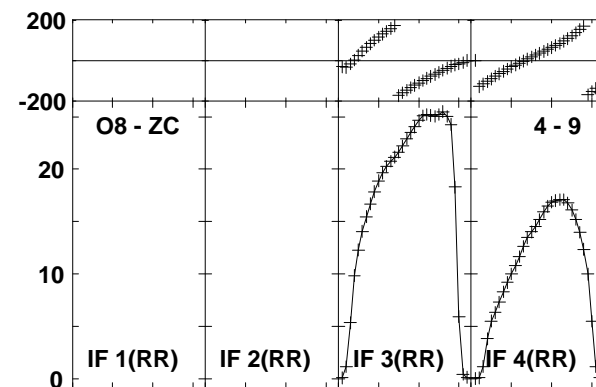
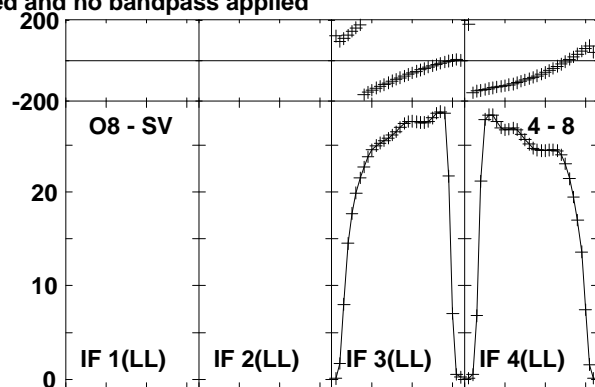
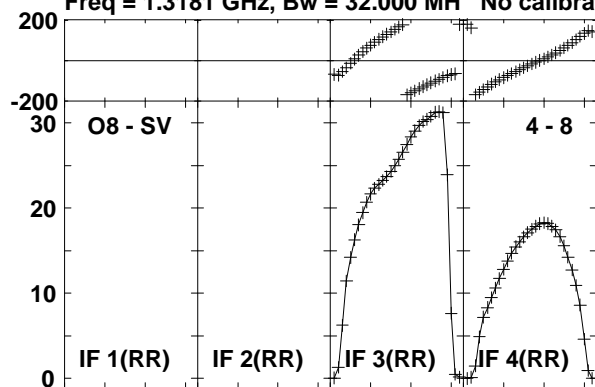

Lower frame: Milli Ampl Jy Top frame: Phas deg
Vector averaged cross-power spectrum Baseline: O8 (04) - SV (08)
Timerange: 00/12:59:58 to 00/13:09:54

Plot file version 174 created 20-NOV-2015 13:44:02

3C84 EO013 1.UVDATA.1

Freq = 1.3181 GHz, Bw = 32.000 MH No calibration applied and no bandpass applied

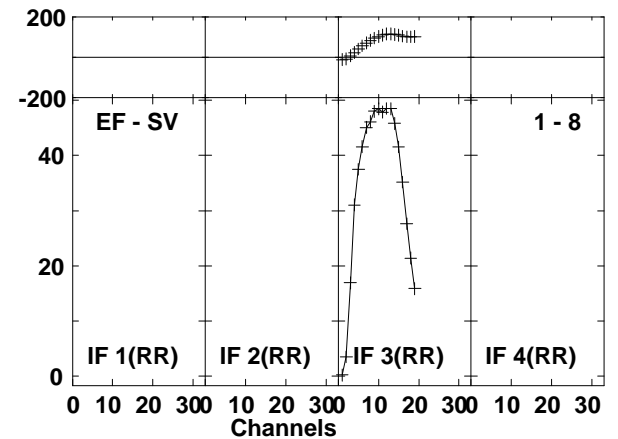
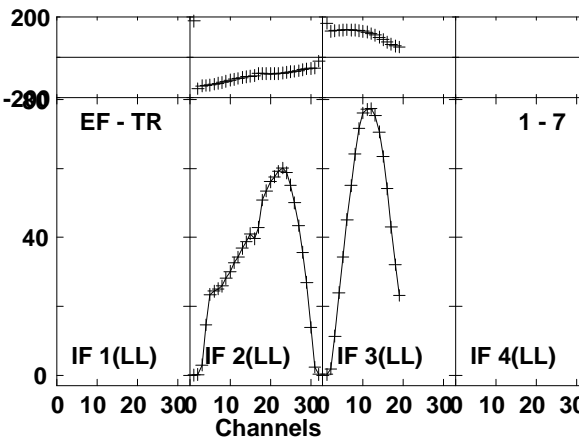
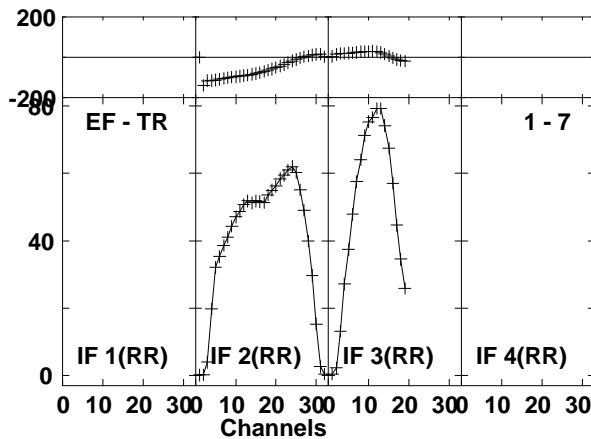
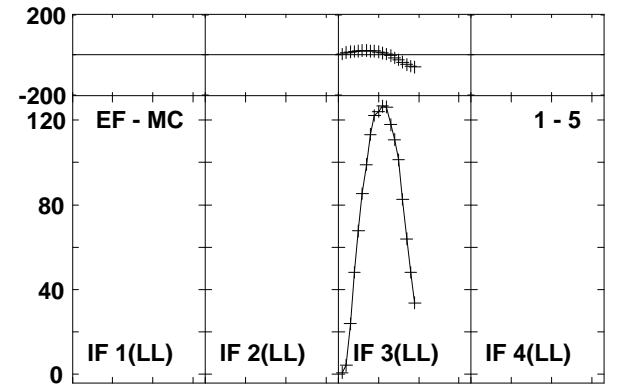
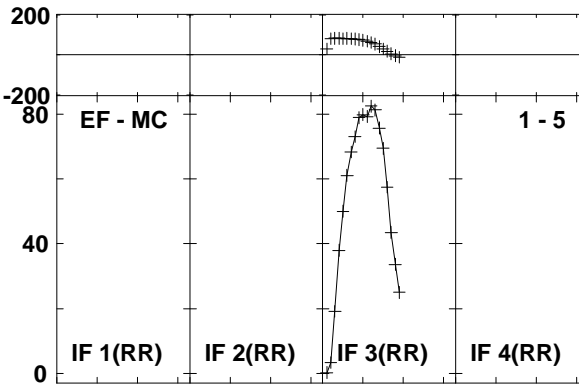
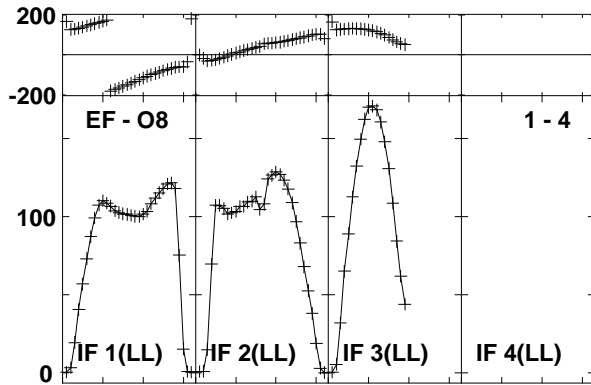
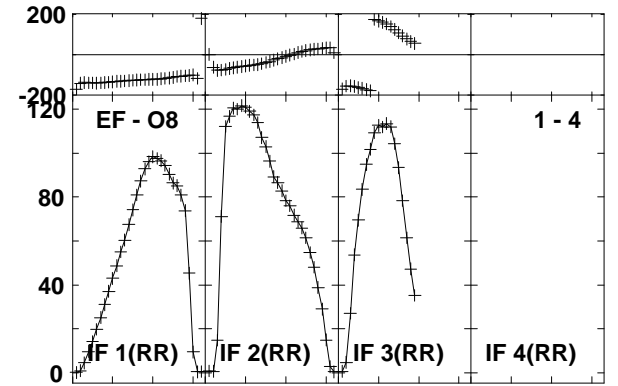
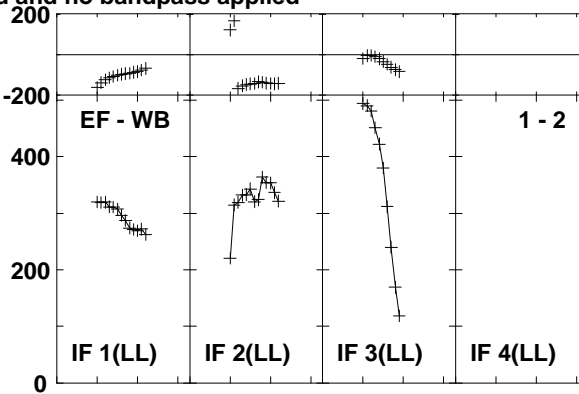
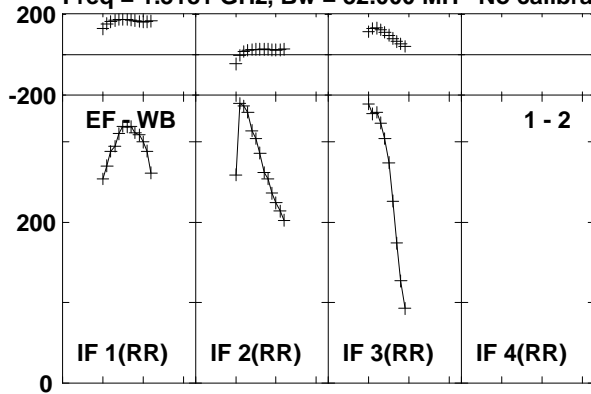

Lower frame: Milli Ampl Jy Top frame: Phas deg
Vector averaged cross-power spectrum Baseline: EF (01) - WB (02)
Timerange: 00/13:10:28 to 00/13:20:24

Plot file version 175 created 20-NOV-2015 13:44:02
 3C84 EO013 1.UVDATA.1
 Freq = 1.3181 GHz, Bw = 32.000 MH No calibration applied and no bandpass applied

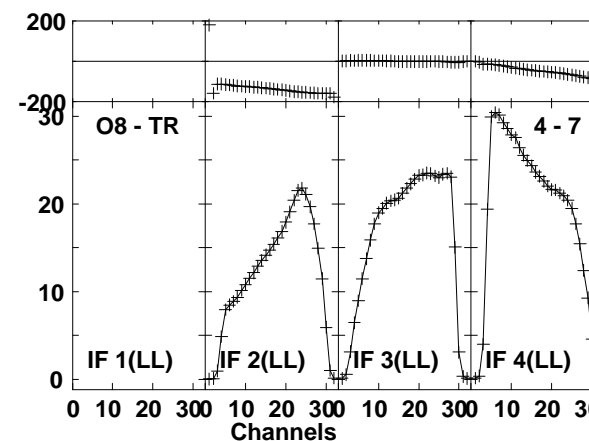
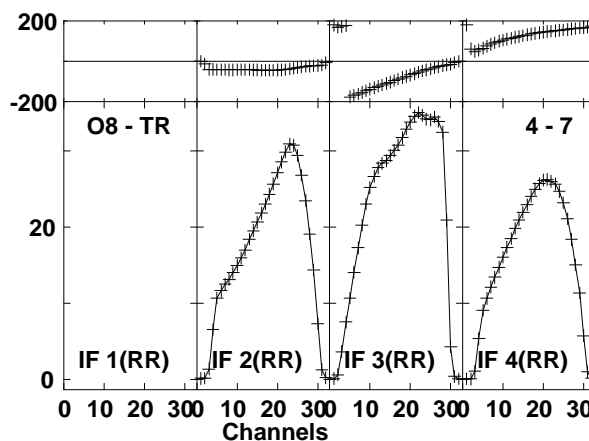
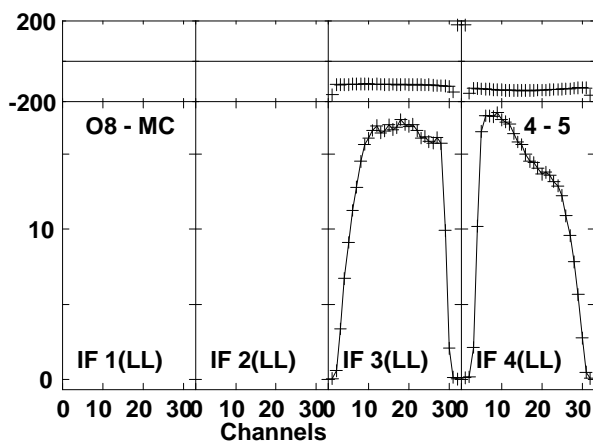
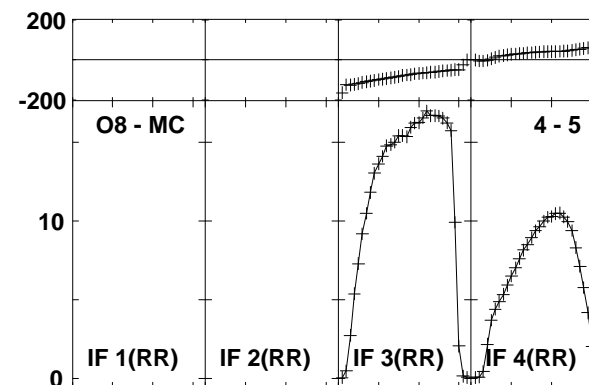
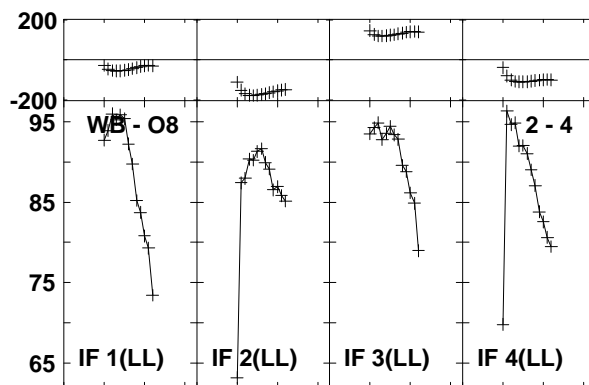
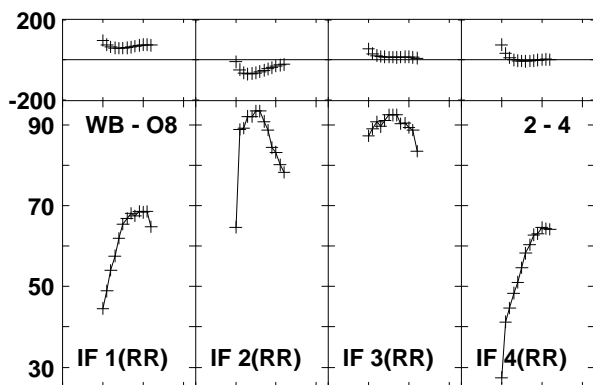
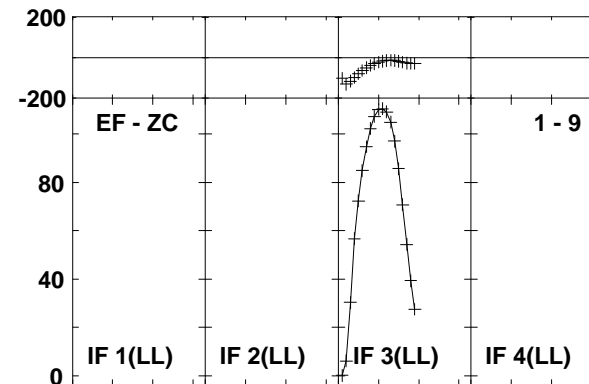
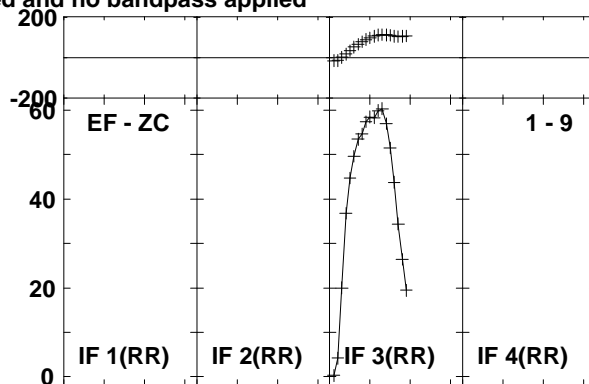
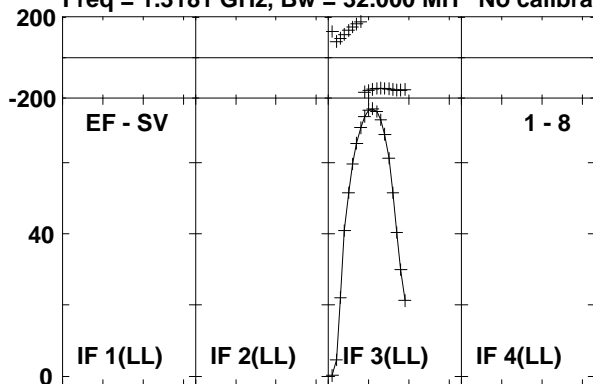

Lower frame: Milli Ampl Jy Top frame: Phas deg
 Vector averaged cross-power spectrum Baseline: EF (01) - SV (08)
 Timerange: 00/13:10:28 to 00/13:20:24

Plot file version 176 created 20-NOV-2015 13:44:02

3C84 EO013 1.UVDATA.1

Freq = 1.3181 GHz, Bw = 32.000 MH No calibration applied and no bandpass applied

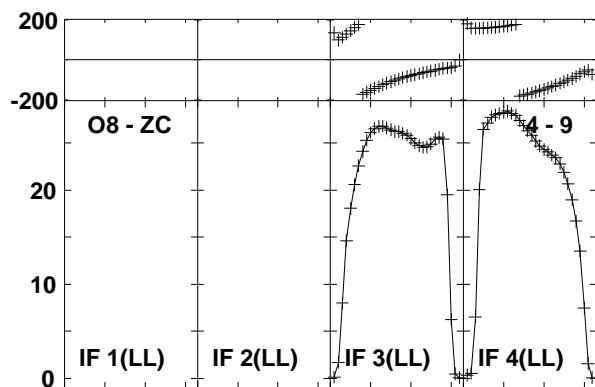
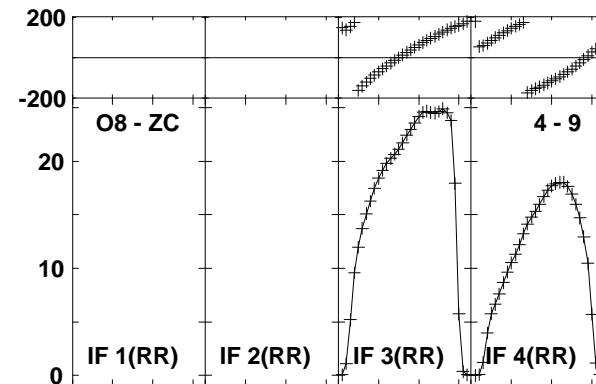
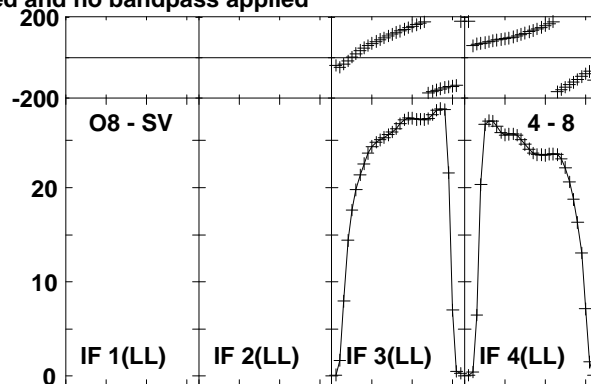
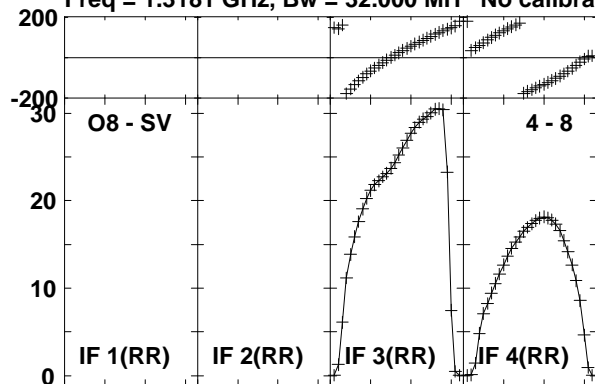

Lower frame: Milli Ampl Jy Top frame: Phas deg
Vector averaged cross-power spectrum Baseline: O8 (04) - SV (08)
Timerange: 00/13:10:28 to 00/13:20:24

Plot file version 177 created 20-NOV-2015 13:44:02
 DA193 EO013 1.UVDATA.1

Freq = 1.3181 GHz, Bw = 32.000 MH No calibration applied and no bandpass applied

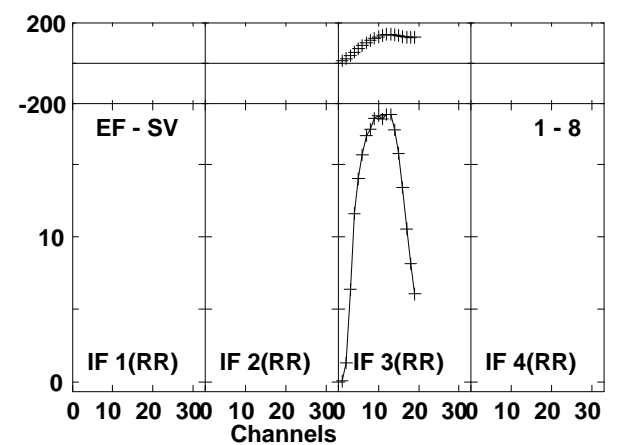
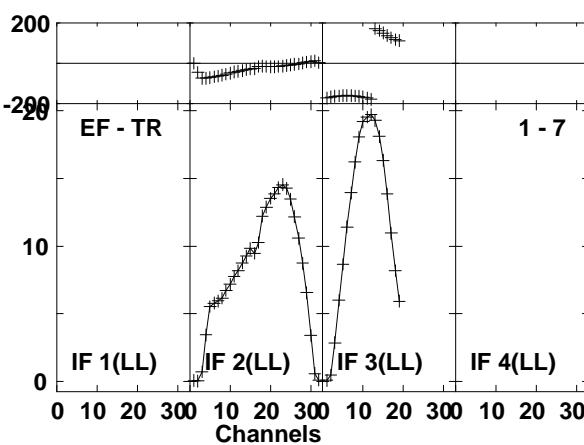
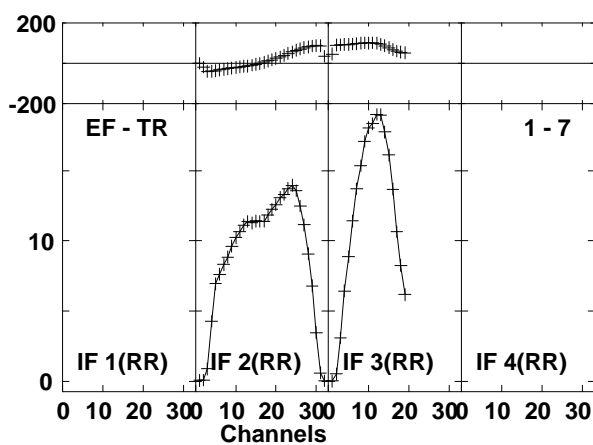
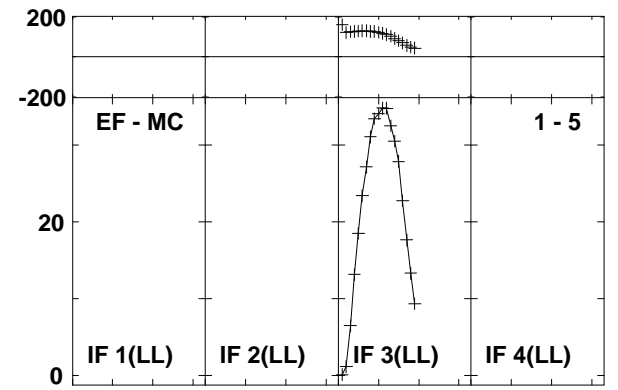
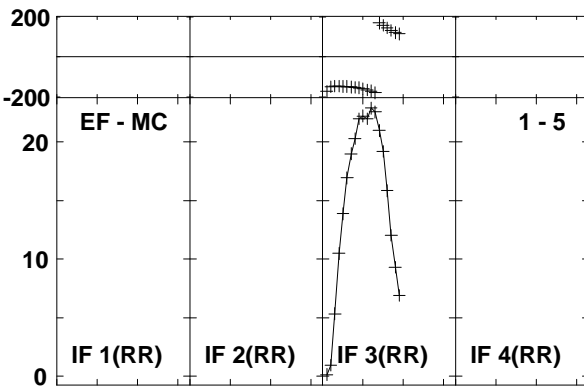
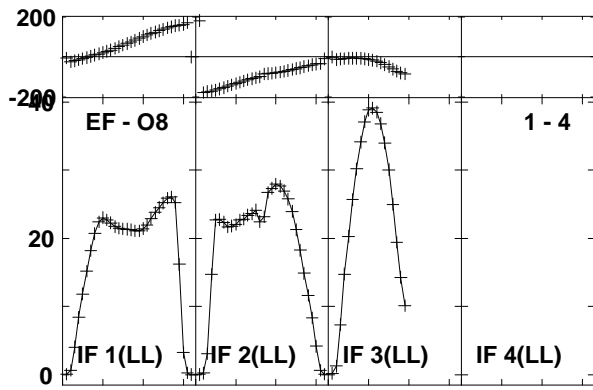
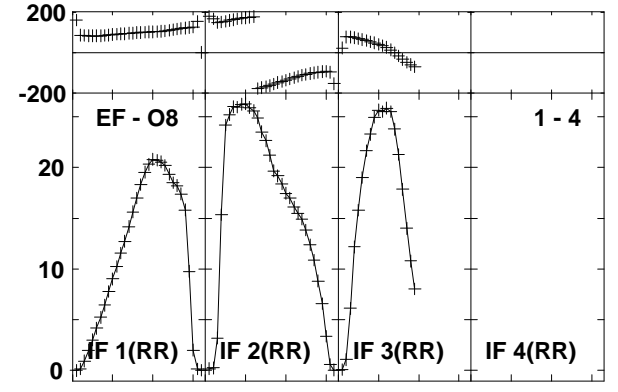
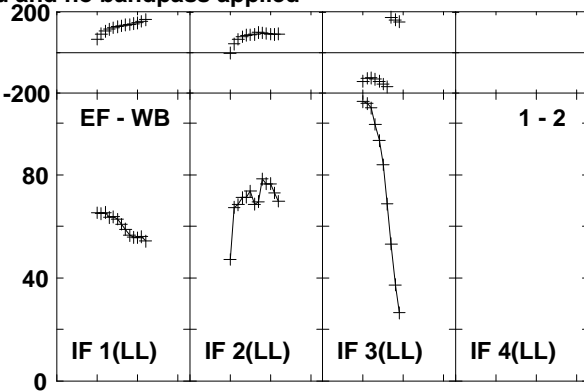
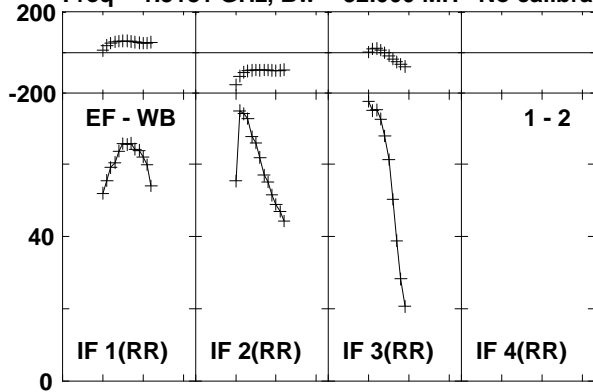

Lower frame: Milli Ampl Jy Top frame: Phas deg
 Vector averaged cross-power spectrum Baseline: EF (01) - WB (02)
 Timerange: 00/13:24:03 to 00/13:33:59

Plot file version 178 created 20-NOV-2015 13:44:02

DA193 EO013 1.UVDATA.1

Freq = 1.3181 GHz, Bw = 32.000 MH No calibration applied and no bandpass applied

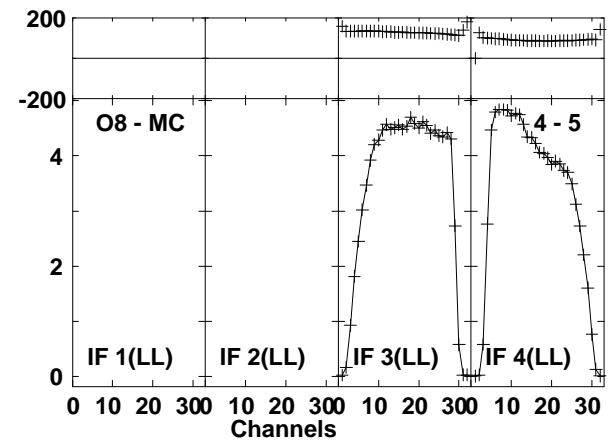
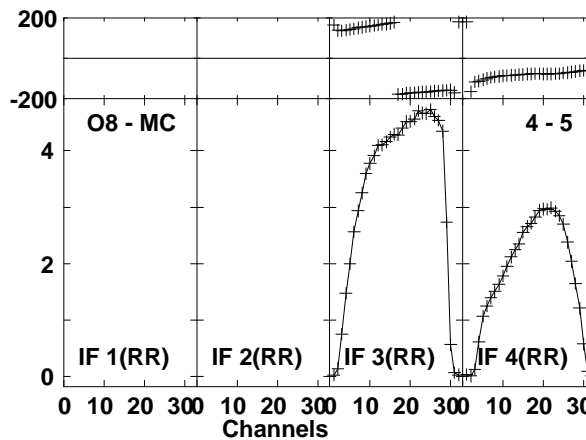
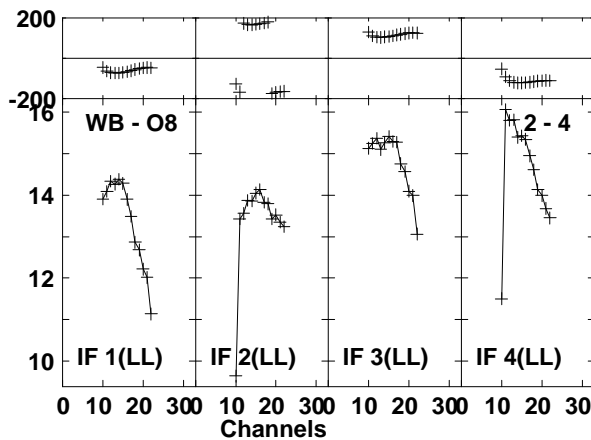
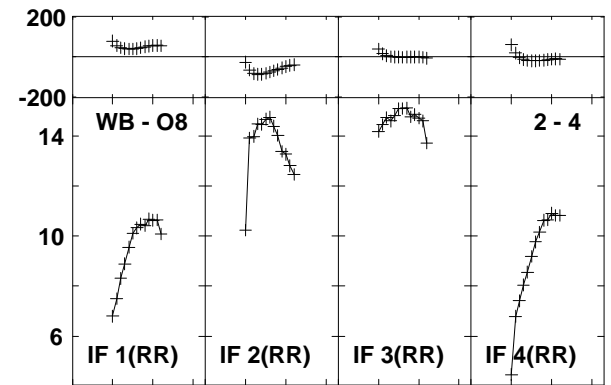
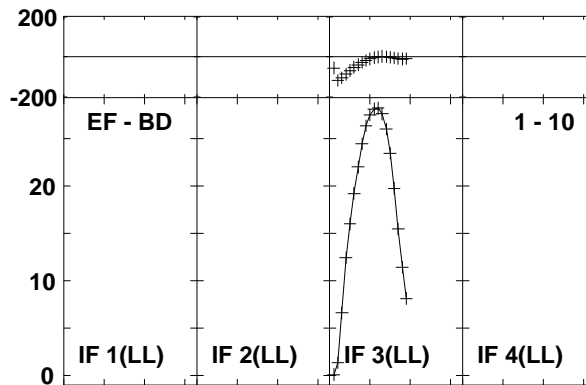
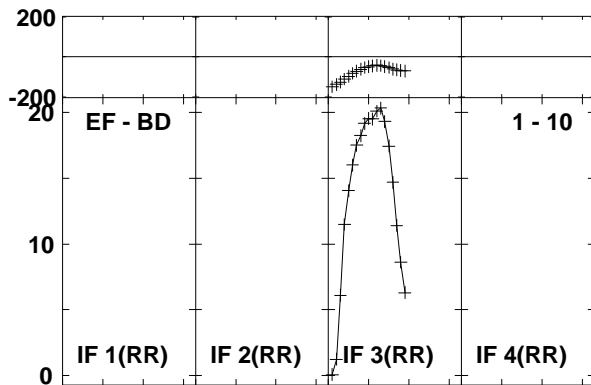
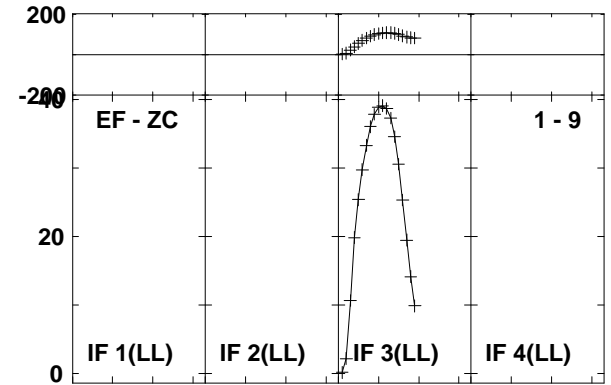
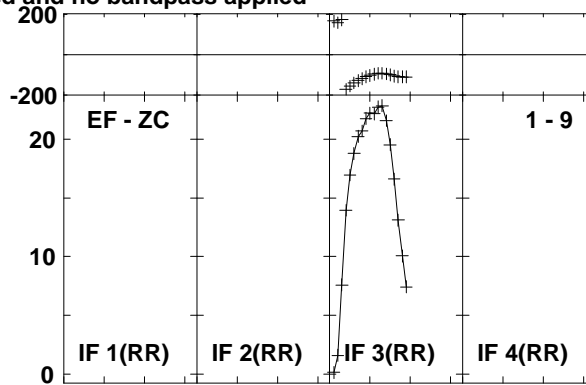
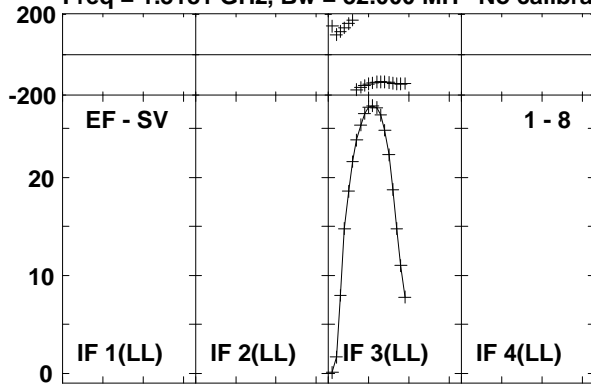

Lower frame: Milli Ampl Jy Top frame: Phas deg
Vector averaged cross-power spectrum Baseline: EF (01) - SV (08)
Timerange: 00/13:24:03 to 00/13:33:59

Plot file version 179 created 20-NOV-2015 13:44:03

DA193 EO013 1.UVDATA.1

Freq = 1.3181 GHz, Bw = 32.000 MH No calibration applied and no bandpass applied

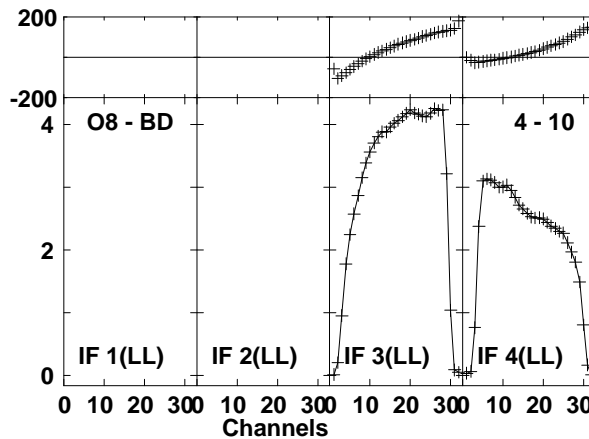
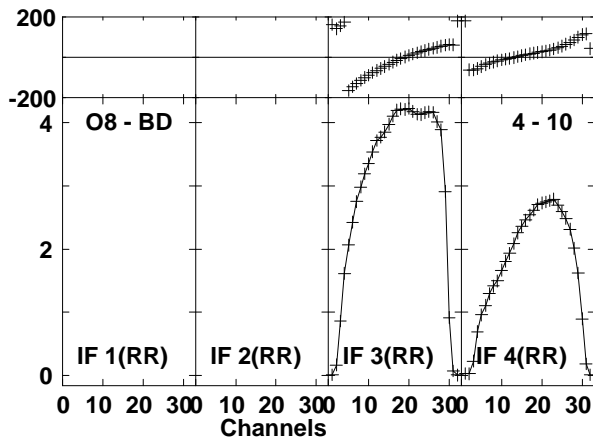
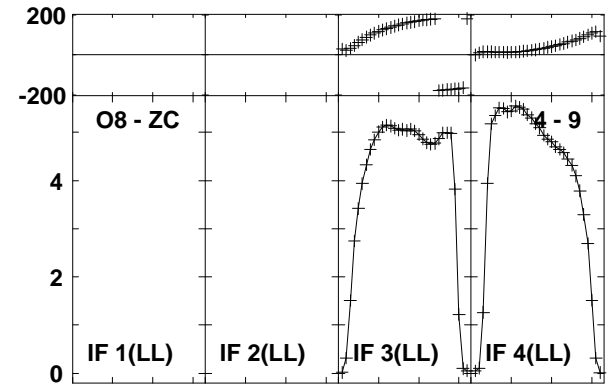
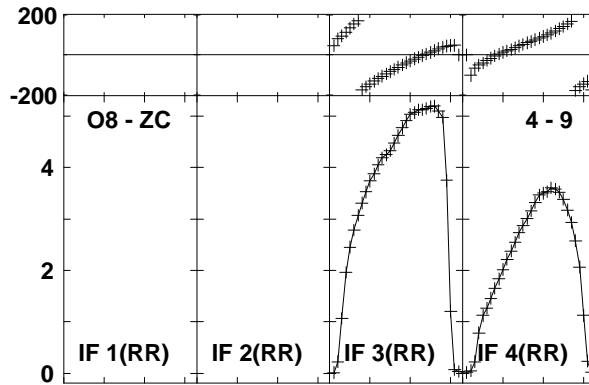
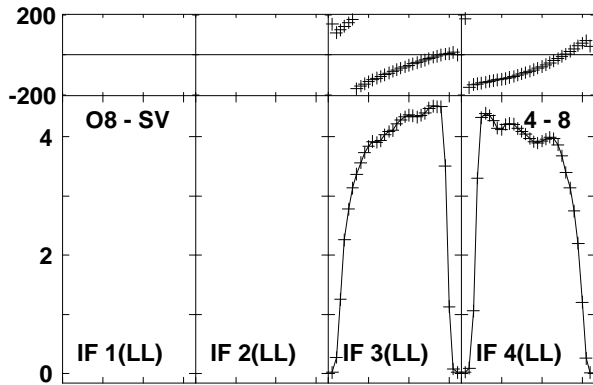
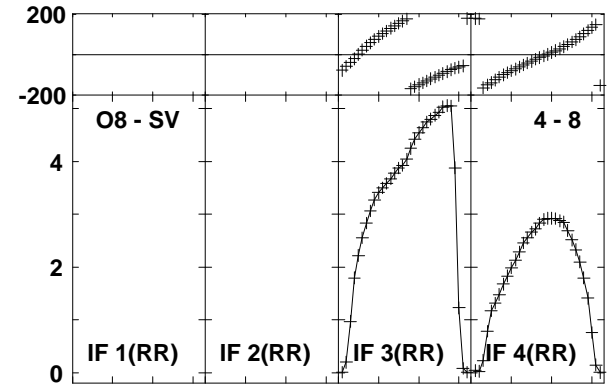
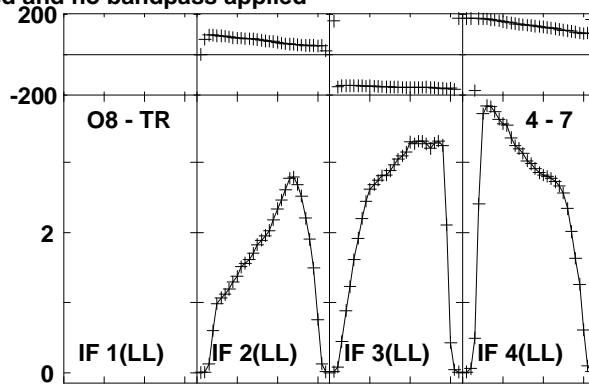
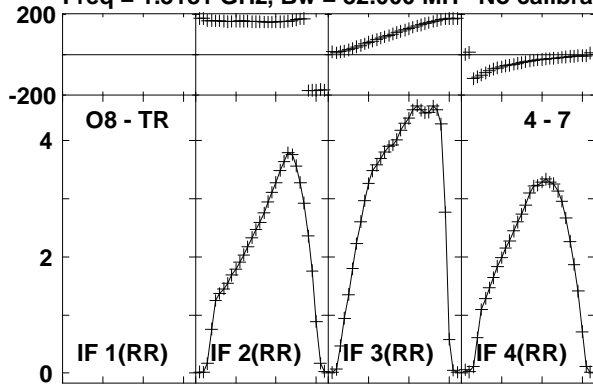

Lower frame: Milli Ampl Jy Top frame: Phas deg
Vector averaged cross-power spectrum Baseline: O8 (04) - TR (07)
Timerange: 00/13:24:03 to 00/13:33:59

Plot file version 180 created 20-NOV-2015 13:44:03

DA193 EO13 1.UVDATA.1

Freq = 1.3181 GHz, Bw = 32.000 MH No calibration applied and no bandpass applied

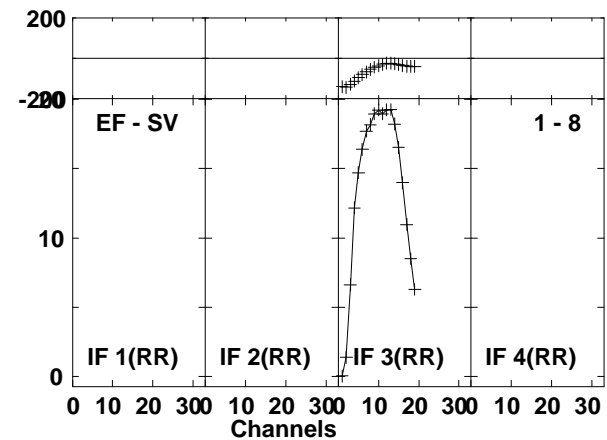
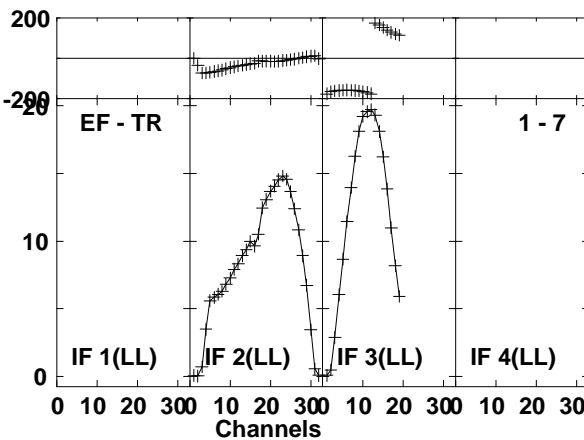
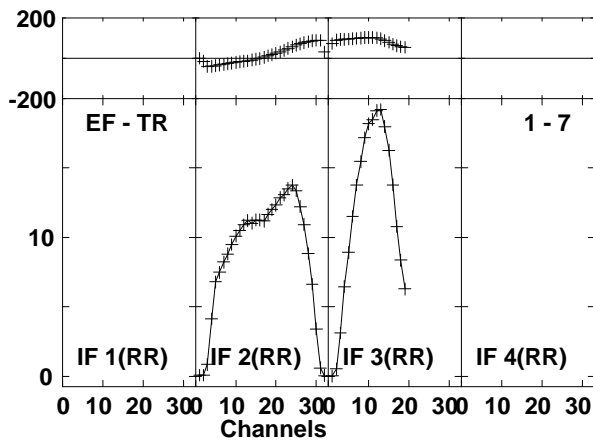
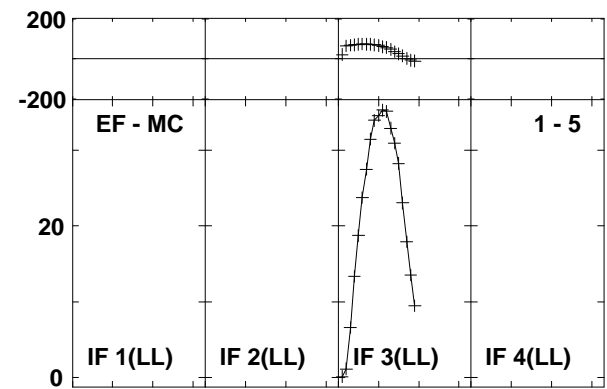
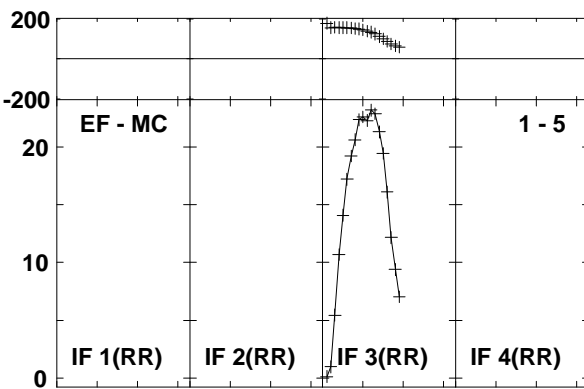
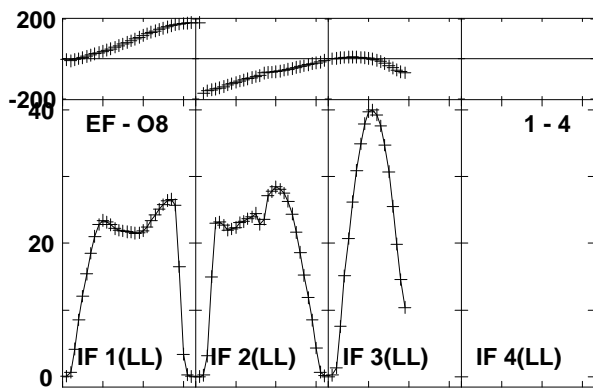
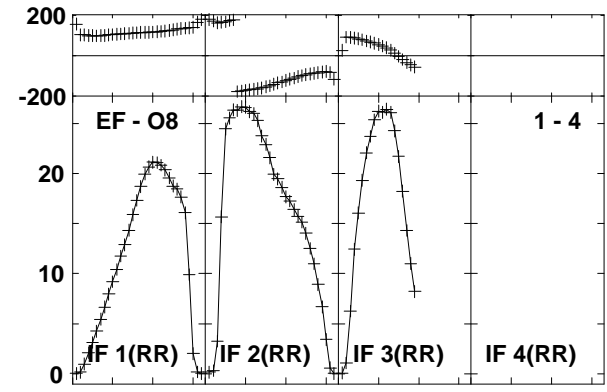
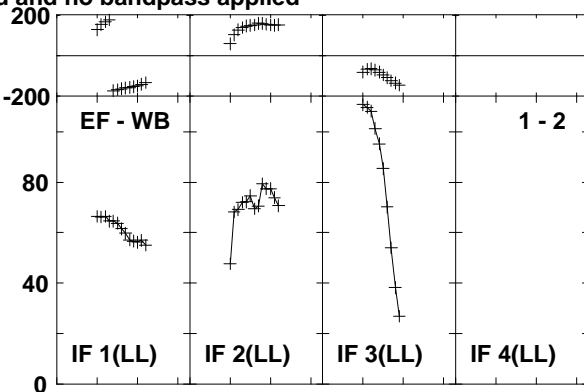
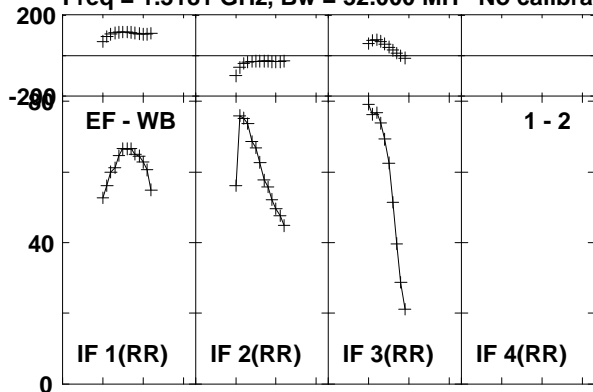

Lower frame: Milli Ampl Jy Top frame: Phas deg
Vector averaged cross-power spectrum Baseline: EF (01) - WB (02)
Timerange: 00/13:34:33 to 00/13:39:29

Plot file version 181 created 20-NOV-2015 13:44:03

DA193 EO013 1.UVDATA.1

Freq = 1.3181 GHz, Bw = 32.000 MH No calibration applied and no bandpass applied

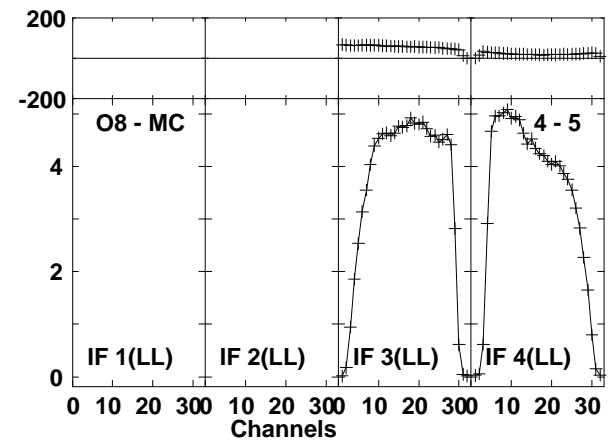
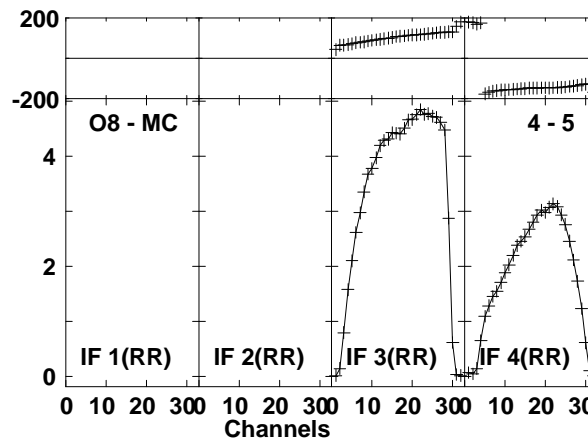
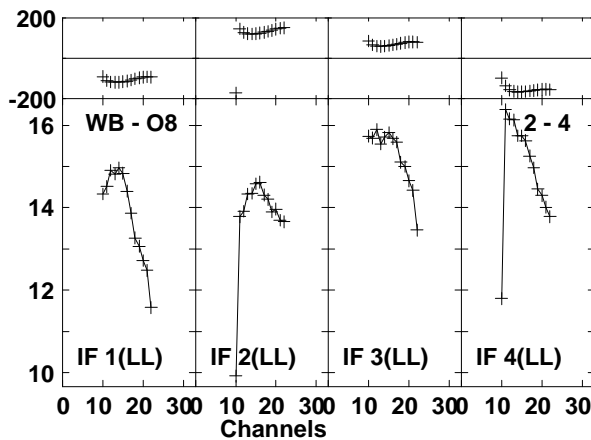
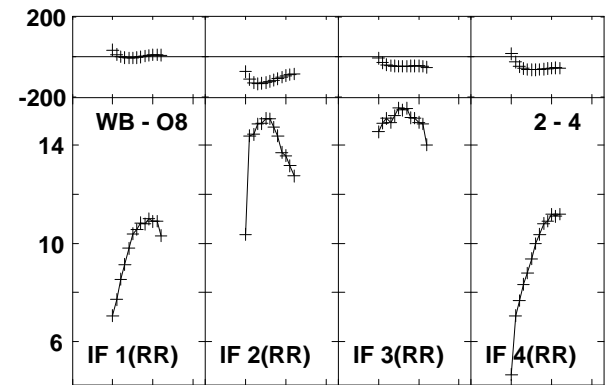
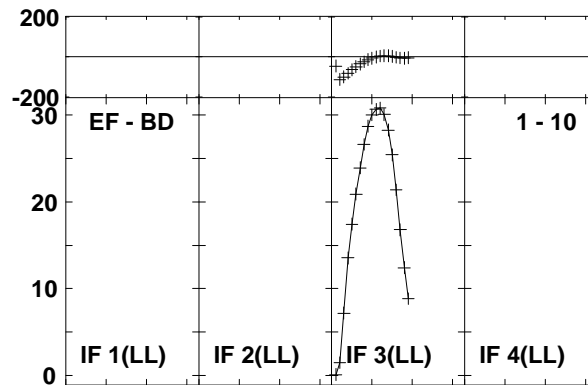
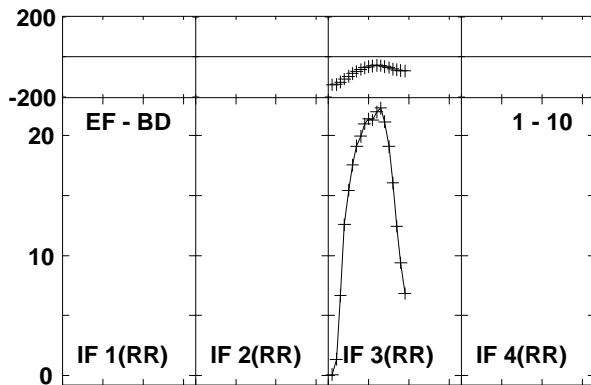
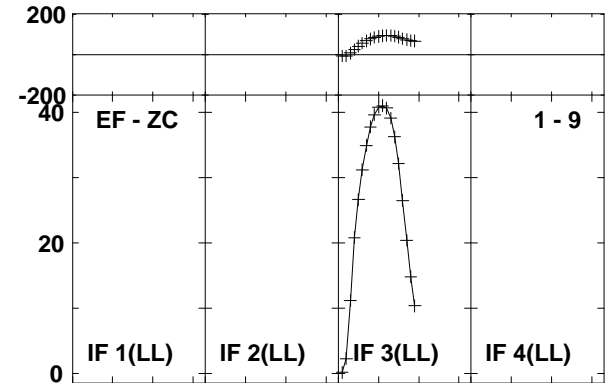
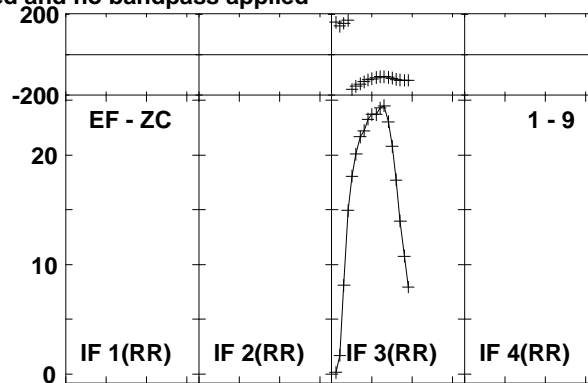
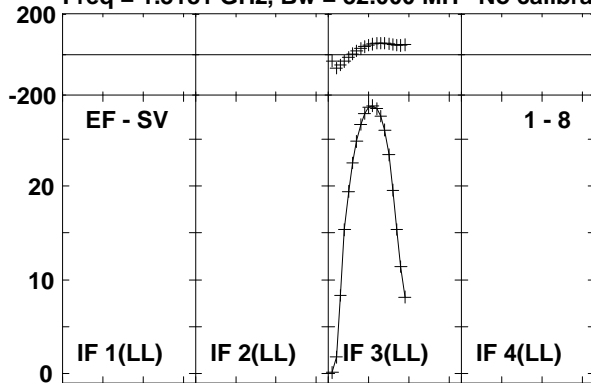

Lower frame: Milli Ampl Jy Top frame: Phas deg
Vector averaged cross-power spectrum Baseline: EF (01) - SV (08)
Timerange: 00/13:34:33 to 00/13:39:29

Plot file version 182 created 20-NOV-2015 13:44:03

DA193 EO013 1.UVDATA.1

Freq = 1.3181 GHz, Bw = 32.000 MH No calibration applied and no bandpass applied

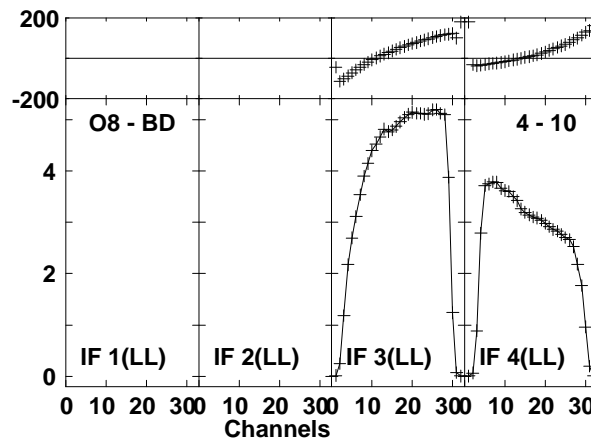
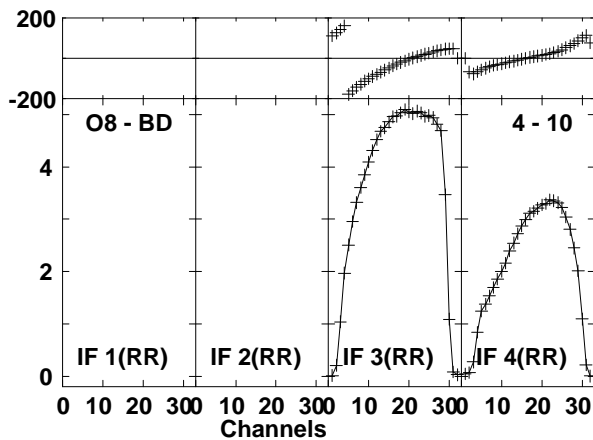
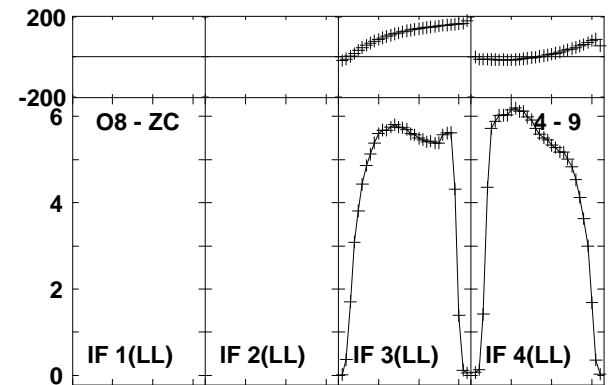
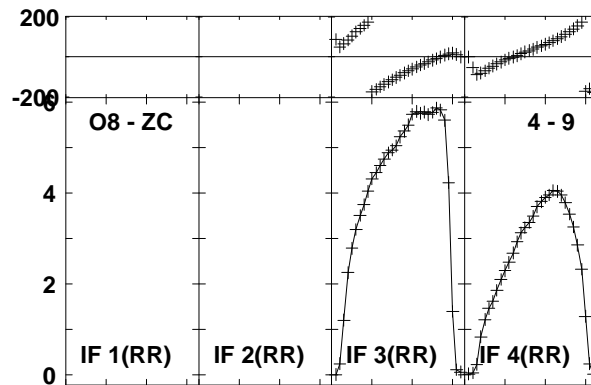
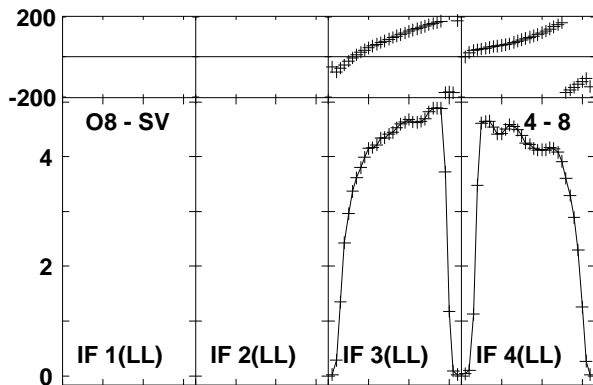
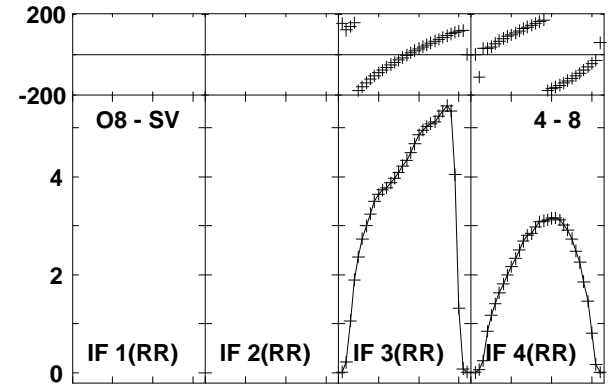
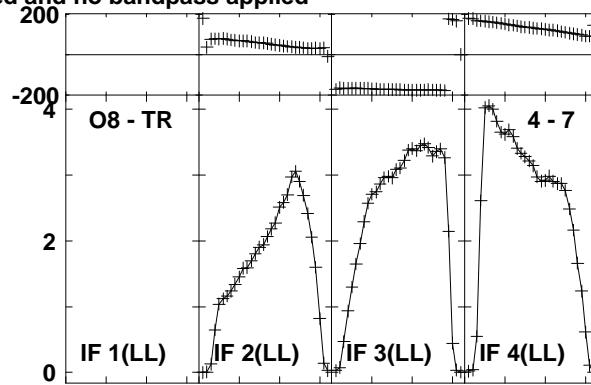
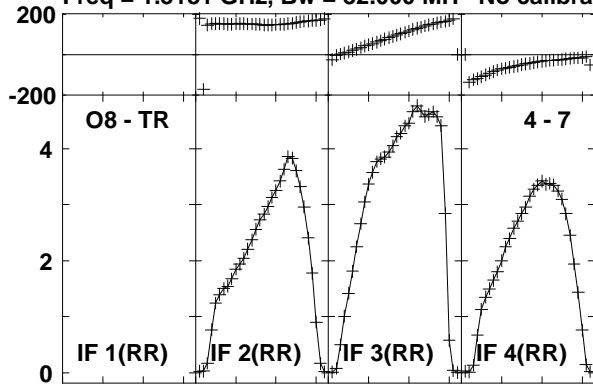

Lower frame: Milli Ampl Jy Top frame: Phas deg
Vector averaged cross-power spectrum Baseline: O8 (04) - TR (07)
Timerange: 00/13:34:33 to 00/13:39:29

Plot file version 183 created 20-NOV-2015 13:44:03

3C84 EO013 1.UVDATA.1

Freq = 1.3181 GHz, Bw = 32.000 MH No calibration applied and no bandpass applied

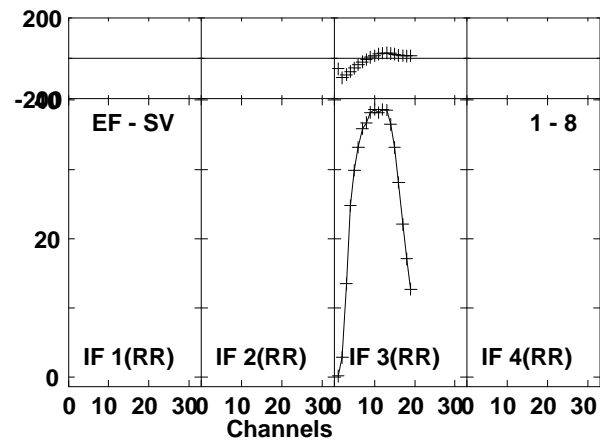
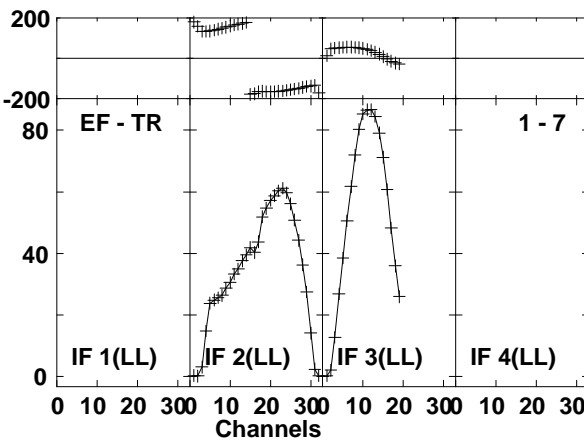
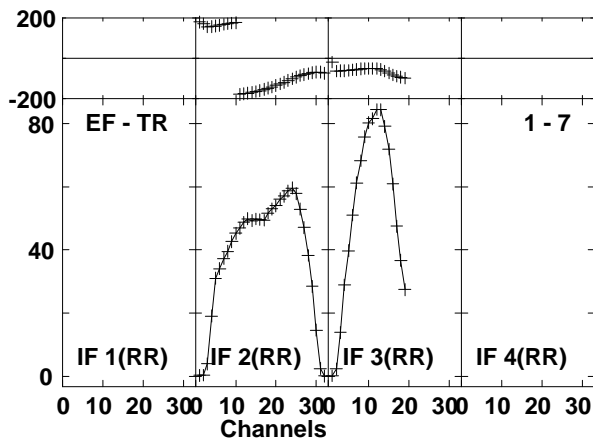
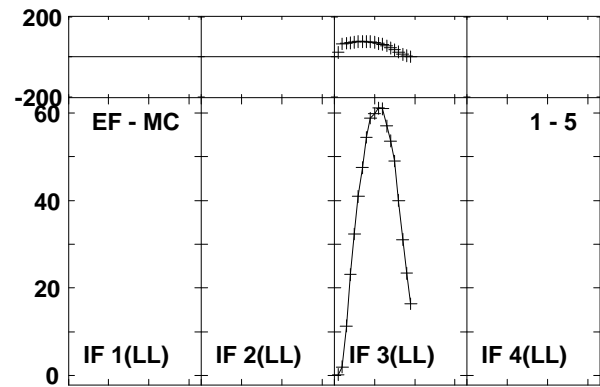
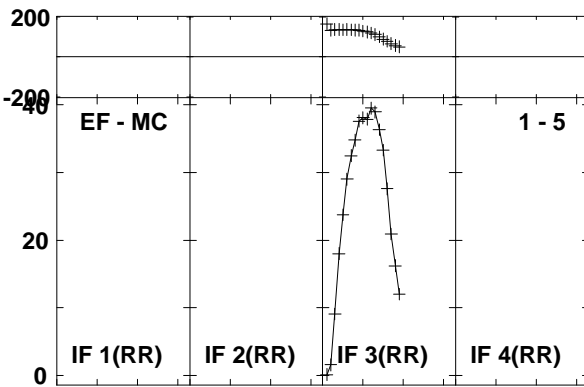
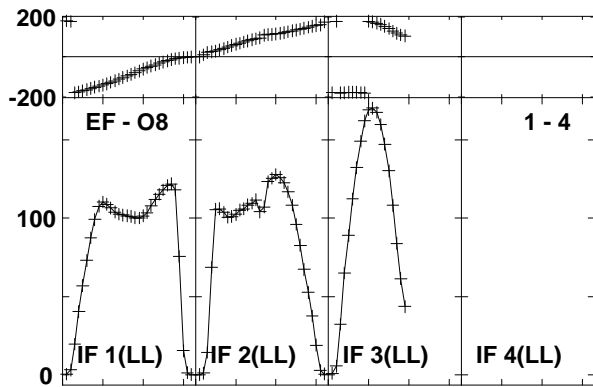
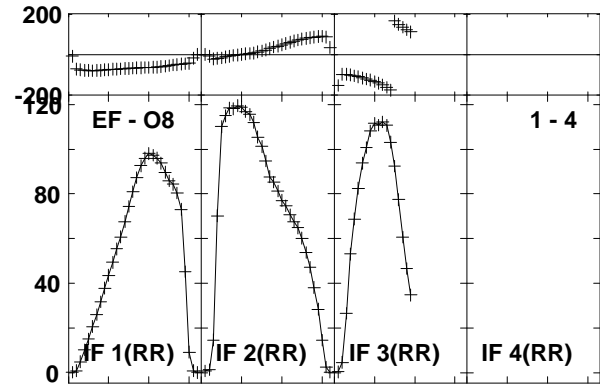
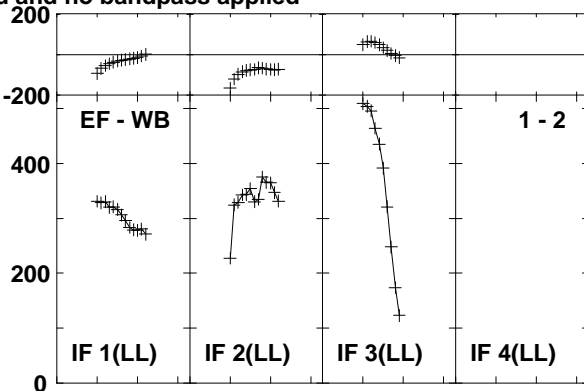
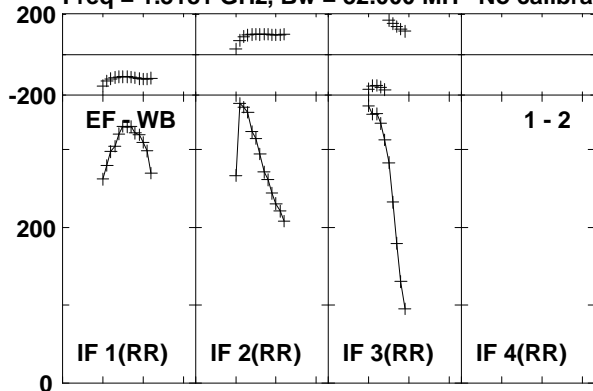

Lower frame: Milli Ampl Jy Top frame: Phas deg
Vector averaged cross-power spectrum Baseline: EF (01) - WB (02)
Timerange: 00/13:42:53 to 00/13:52:49

Plot file version 184 created 20-NOV-2015 13:44:03

3C84 EO013 1.UVDATA.1

Freq = 1.3181 GHz, Bw = 32.000 MH No calibration applied and no bandpass applied

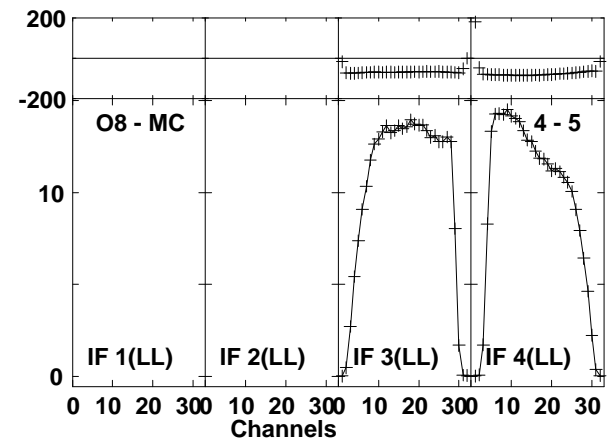
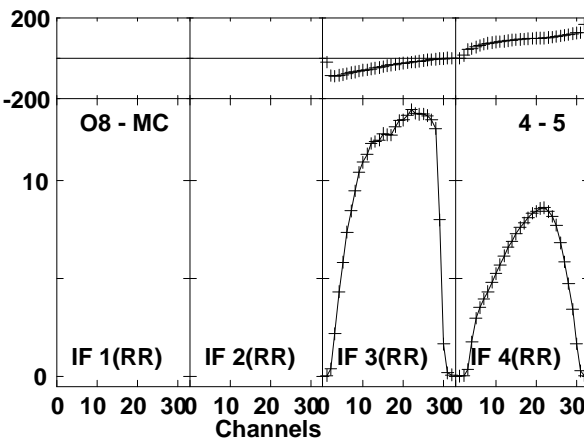
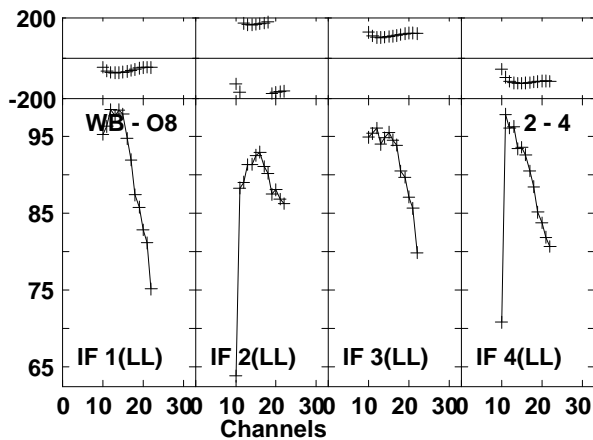
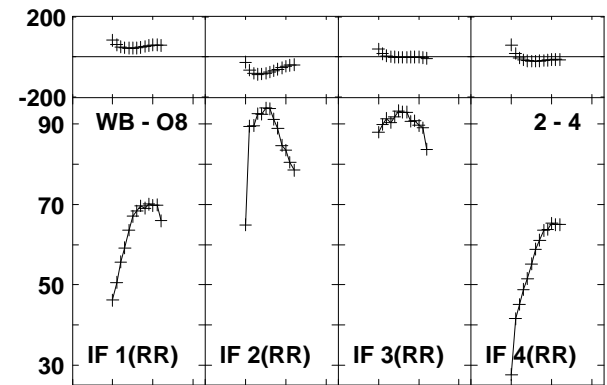
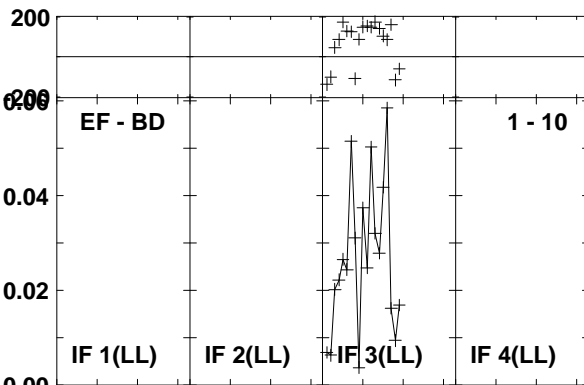
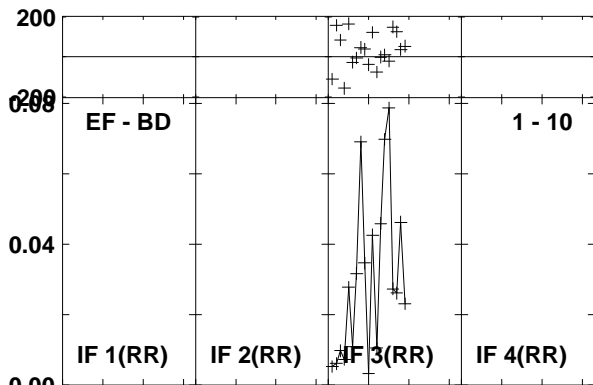
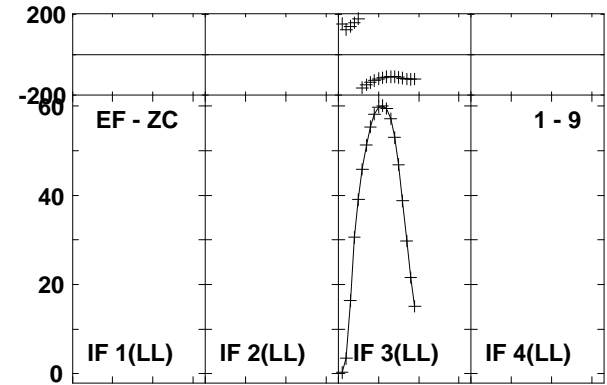
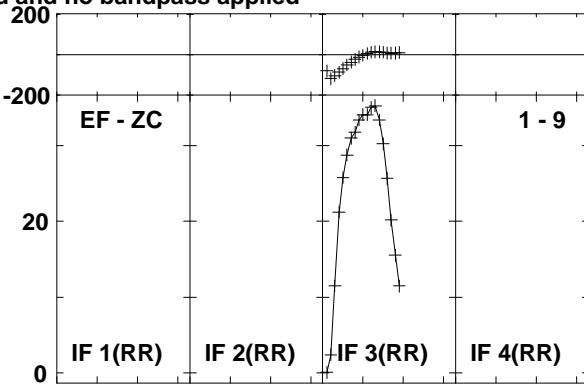
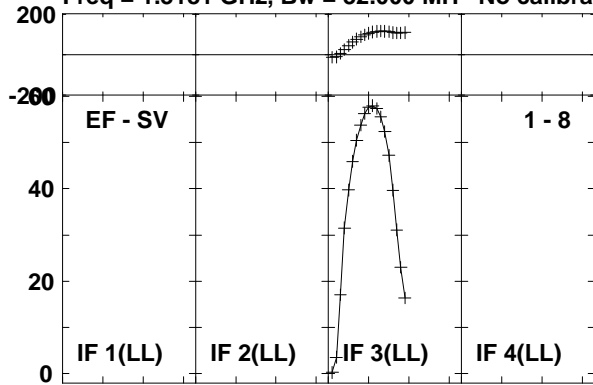

Lower frame: Milli Ampl Jy Top frame: Phas deg
Vector averaged cross-power spectrum Baseline: EF (01) - SV (08)
Timerange: 00/13:42:53 to 00/13:52:49

Plot file version 185 created 20-NOV-2015 13:44:03
 3C84 EO013 1.UVDATA.1
 Freq = 1.3181 GHz, Bw = 32.000 MHz No calibration applied and no bandpass applied

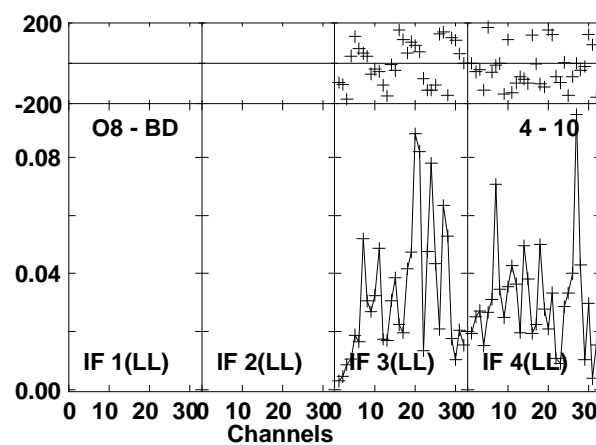
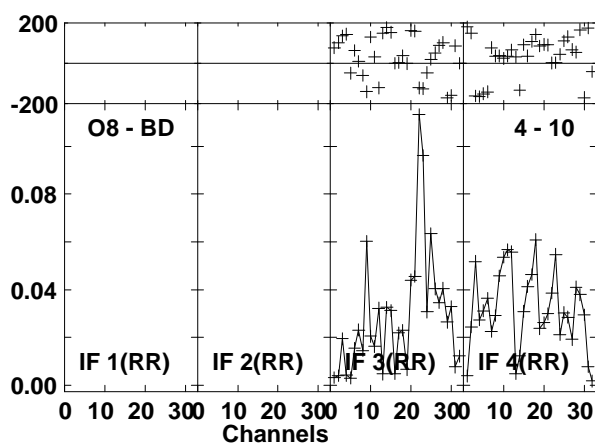
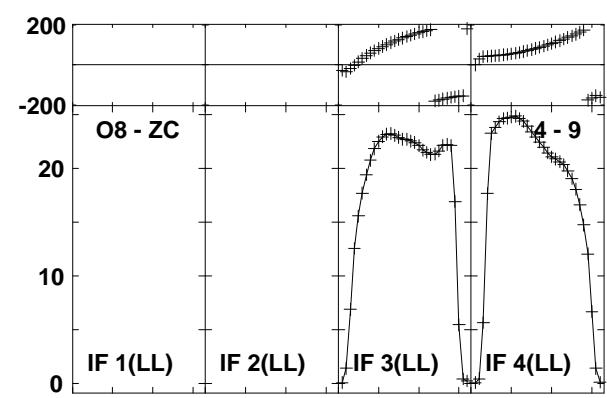
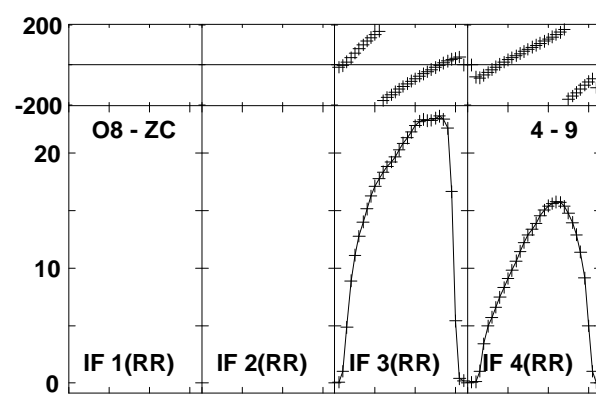
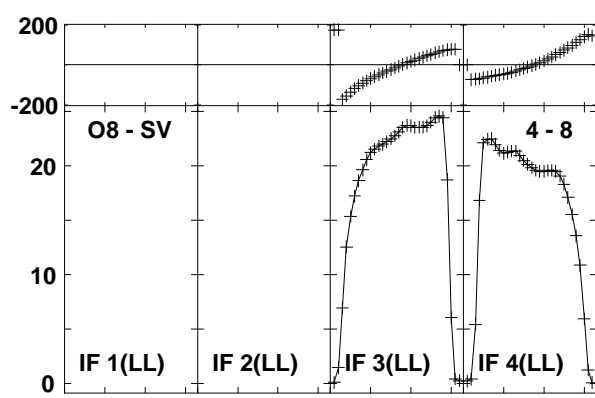
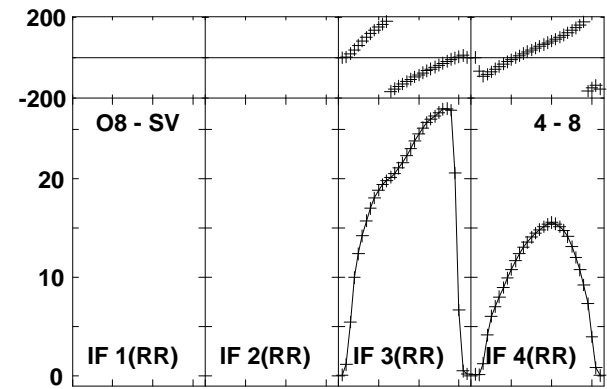
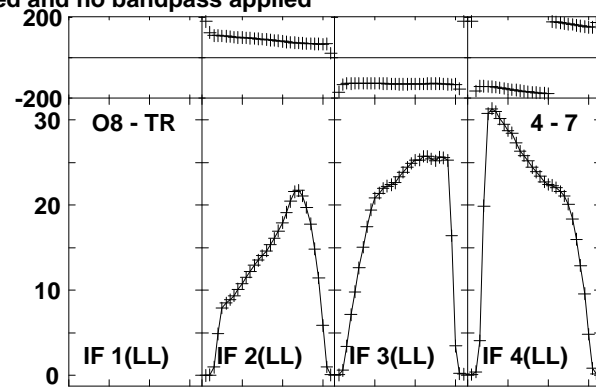
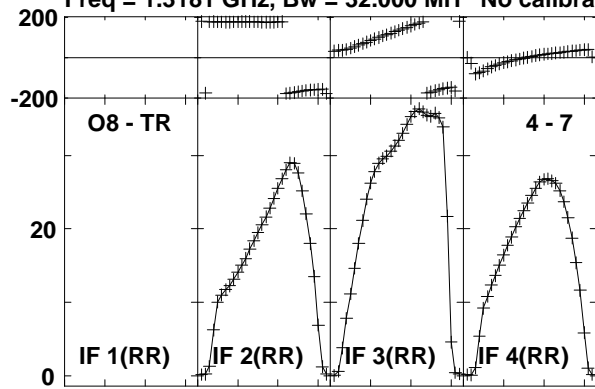

Lower frame: Milli Ampl Jy Top frame: Phas deg
 Vector averaged cross-power spectrum Baseline: O8 (04) - TR (07)
 Timerange: 00/13:42:53 to 00/13:52:49

Plot file version 186 created 20-NOV-2015 13:44:03
 3C84 EO013 1.UVDATA.1

Freq = 1.3181 GHz, Bw = 32.000 MH No calibration applied and no bandpass applied

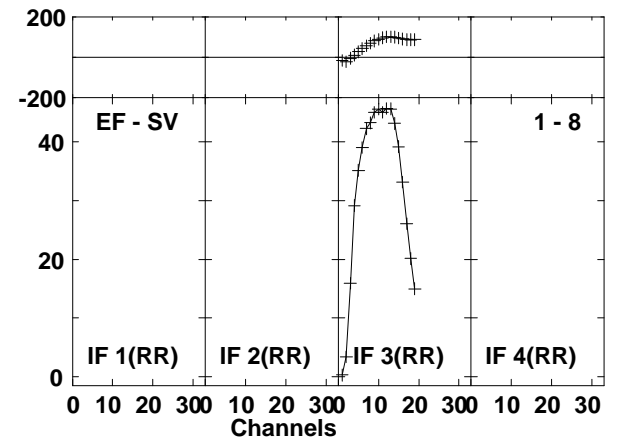
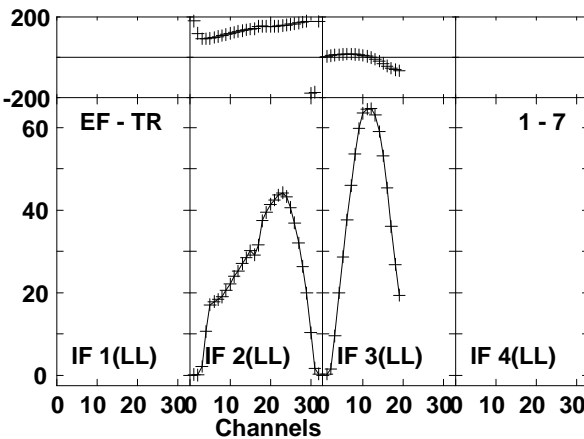
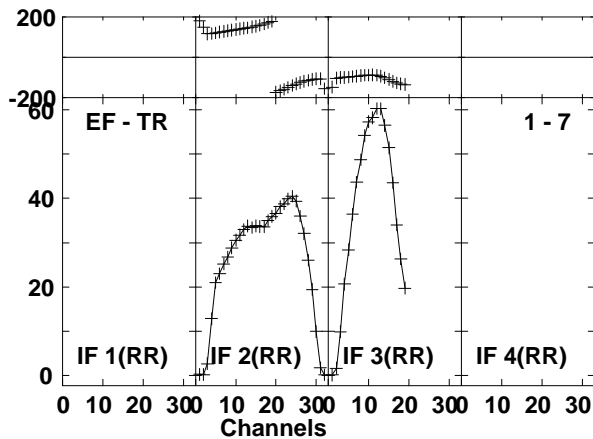
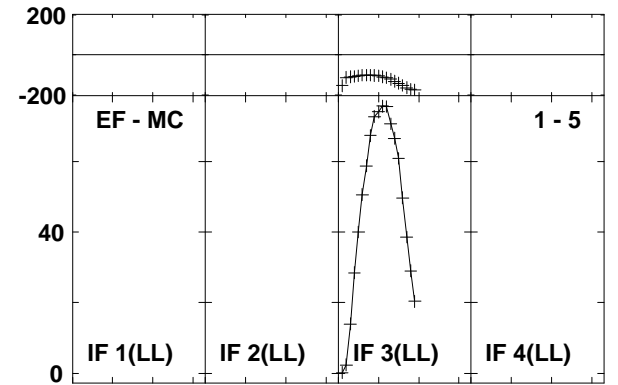
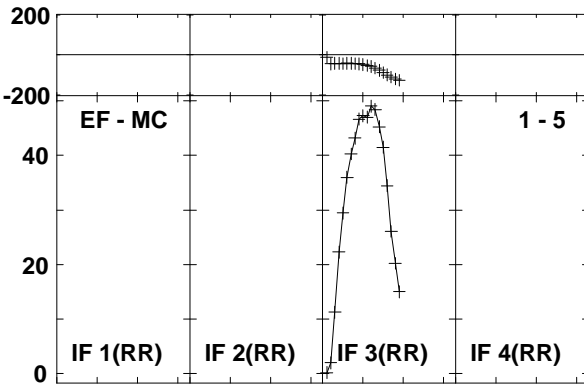
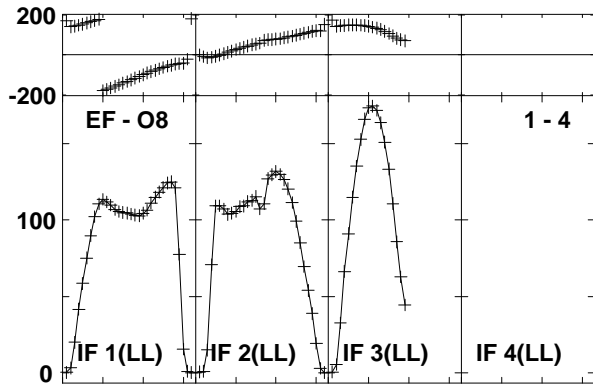
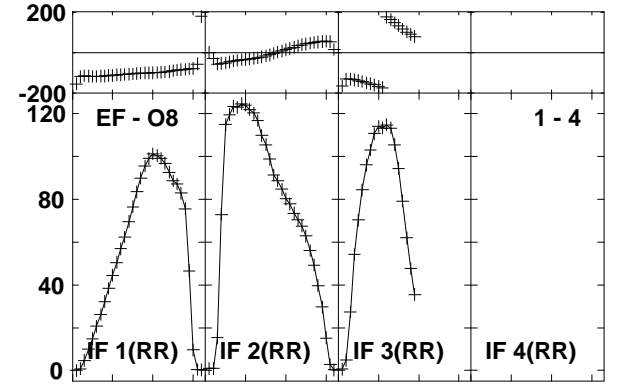
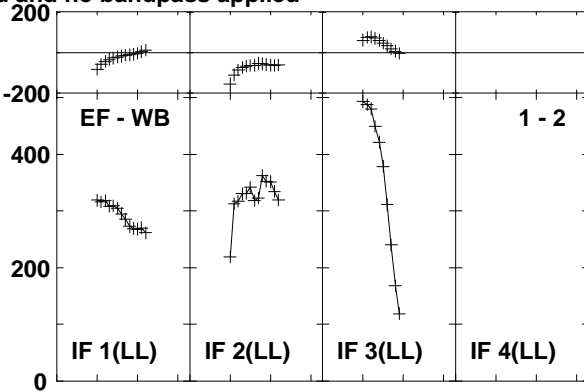
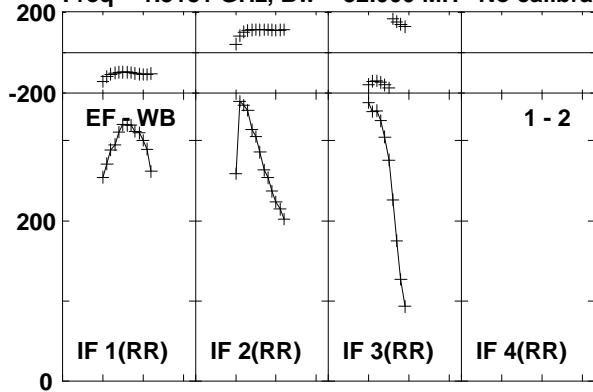

Lower frame: Milli Ampl Jy Top frame: Phas deg
 Vector averaged cross-power spectrum Baseline: EF (01) - WB (02)
 Timerange: 00/13:53:23 to 00/14:03:53

Plot file version 187 created 20-NOV-2015 13:44:03
 3C84 EO013 1.UVDATA.1
 Freq = 1.3181 GHz, Bw = 32.000 MH No calibration applied and no bandpass applied

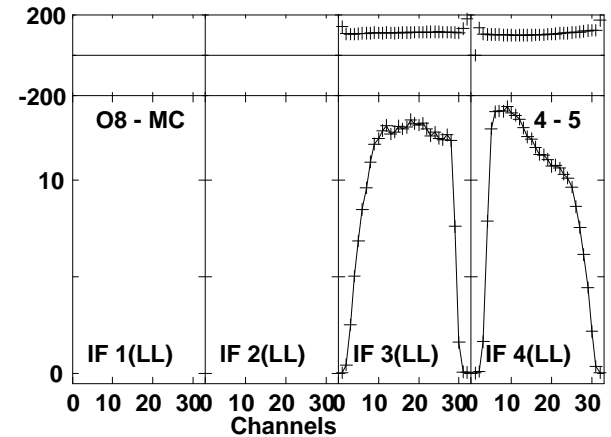
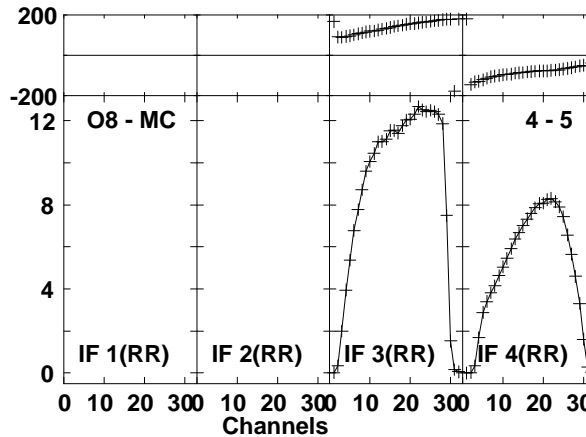
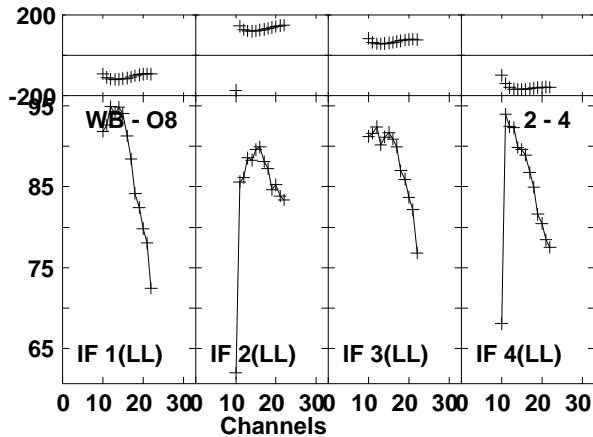
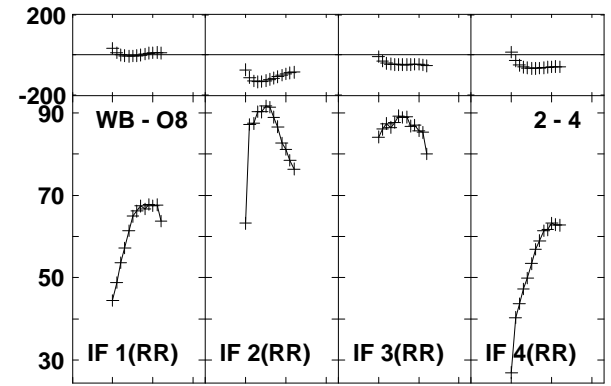
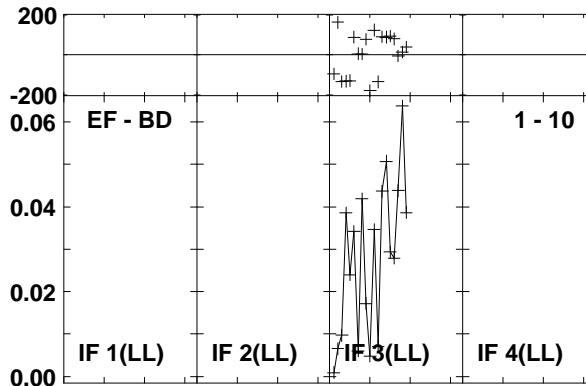
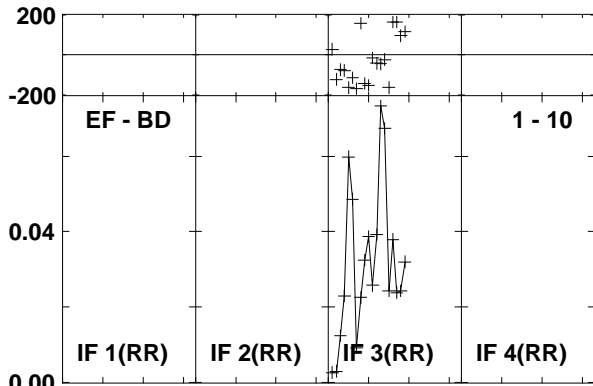
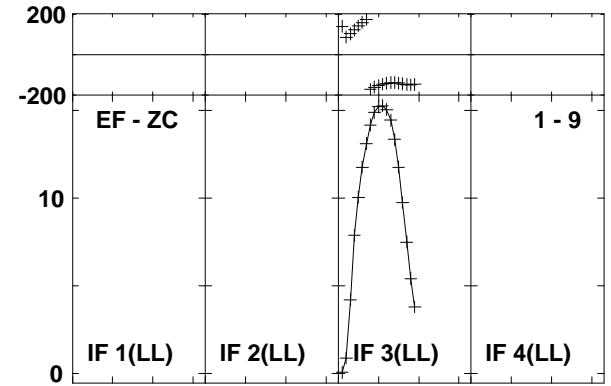
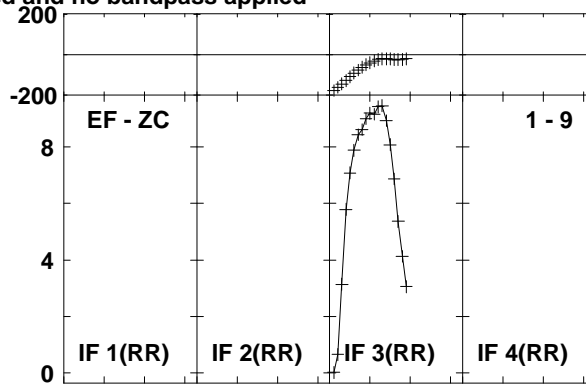
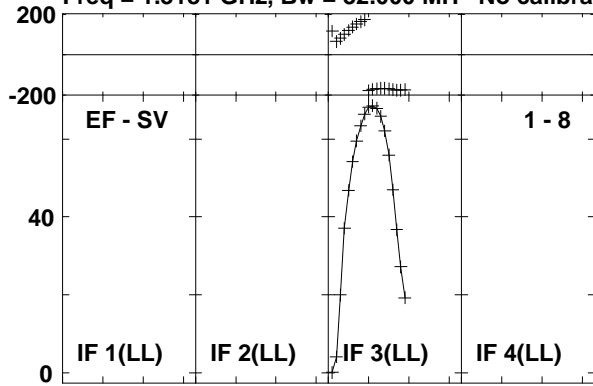

Lower frame: Milli Ampl Jy Top frame: Phas deg
 Vector averaged cross-power spectrum Baseline: EF (01) - SV (08)
 Timerange: 00/13:53:23 to 00/14:03:53

Plot file version 188 created 20-NOV-2015 13:44:03
 3C84 EO013 1.UVDATA.1
 Freq = 1.3181 GHz, Bw = 32.000 MH No calibration applied and no bandpass applied

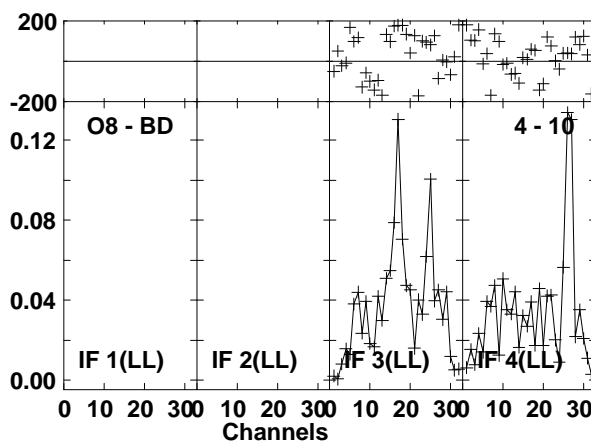
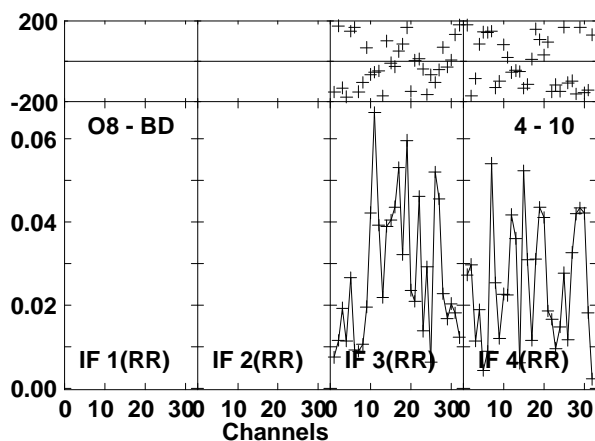
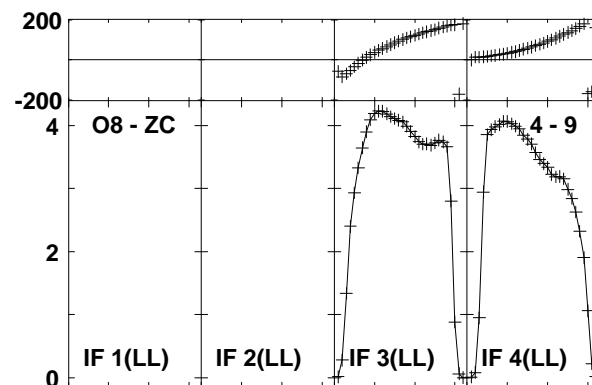
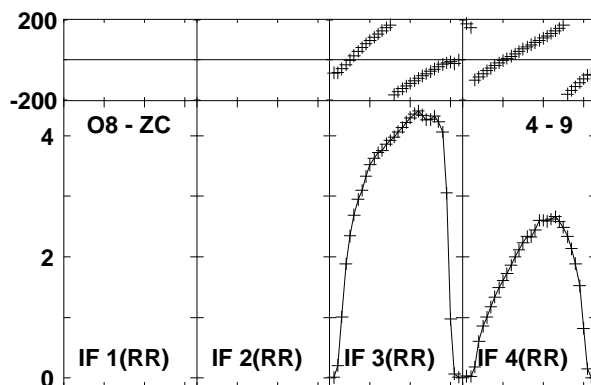
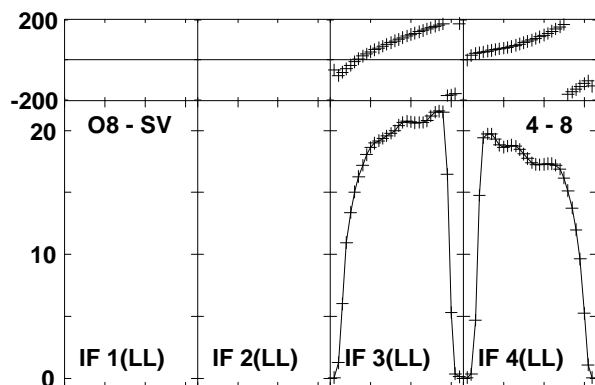
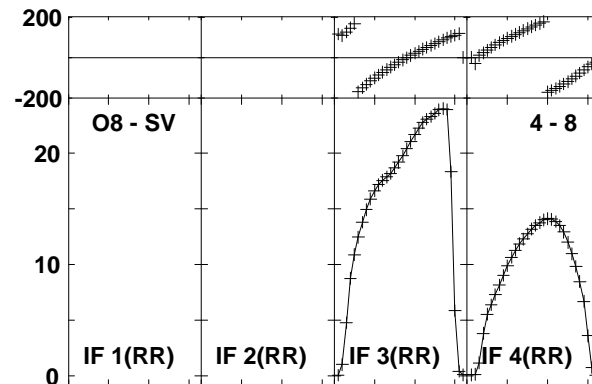
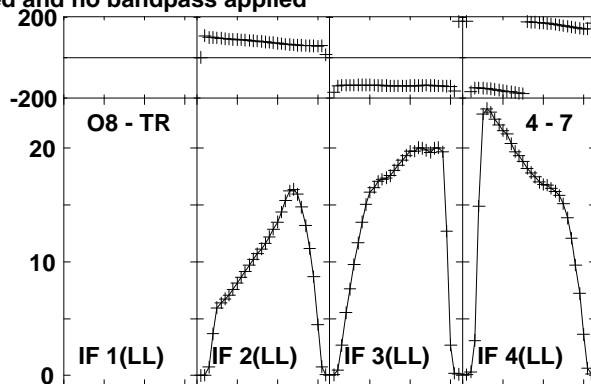
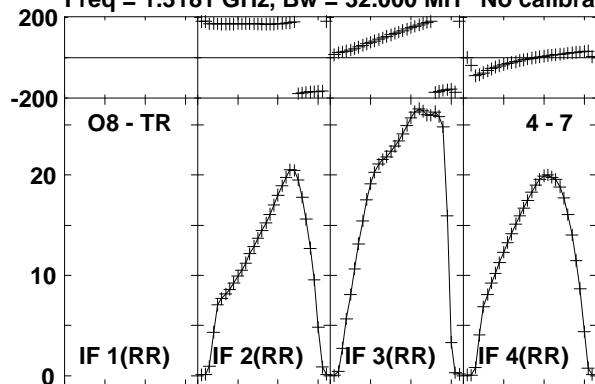

Lower frame: Milli Ampl Jy Top frame: Phas deg
 Vector averaged cross-power spectrum Baseline: O8 (04) - TR (07)
 Timerange: 00/13:53:23 to 00/14:03:53

Plot file version 189 created 20-NOV-2015 13:44:03

3C84 EO013 1.UVDATA.1

Freq = 1.3181 GHz, Bw = 32.000 MH No calibration applied and no bandpass applied

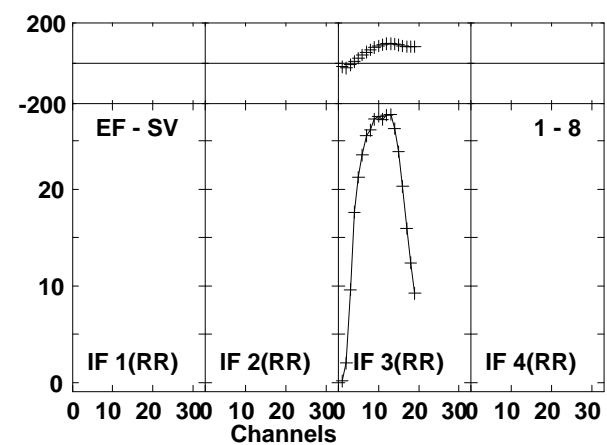
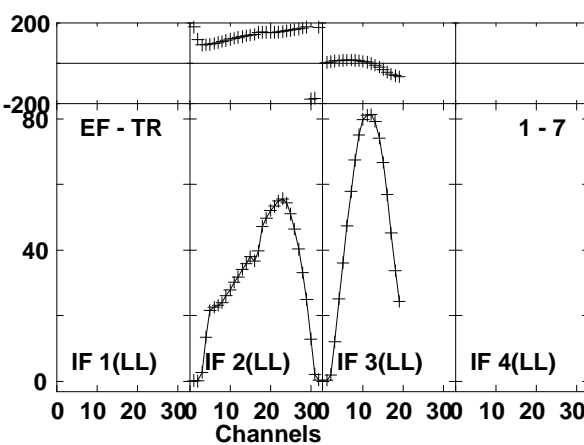
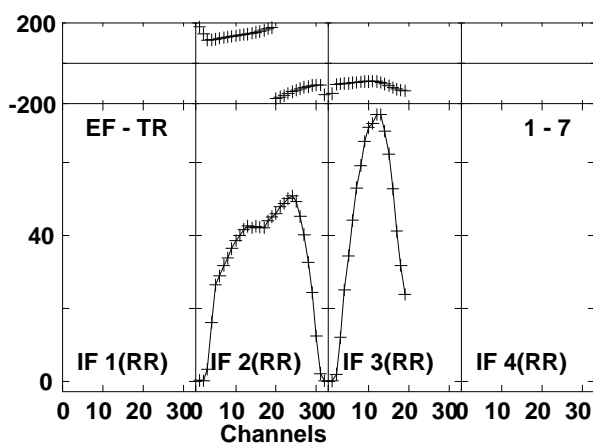
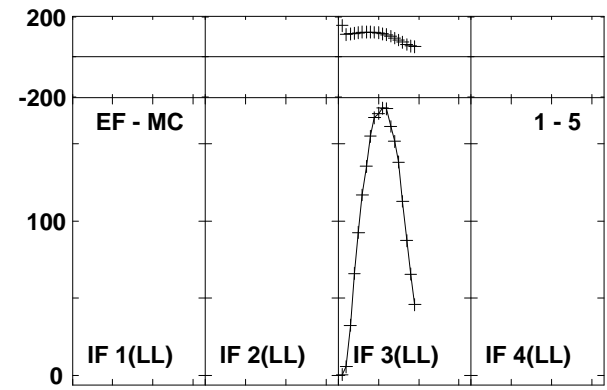
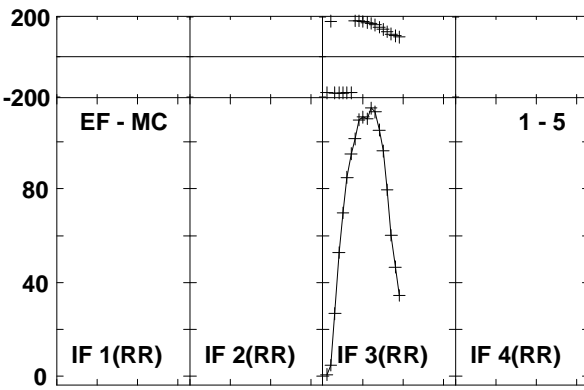
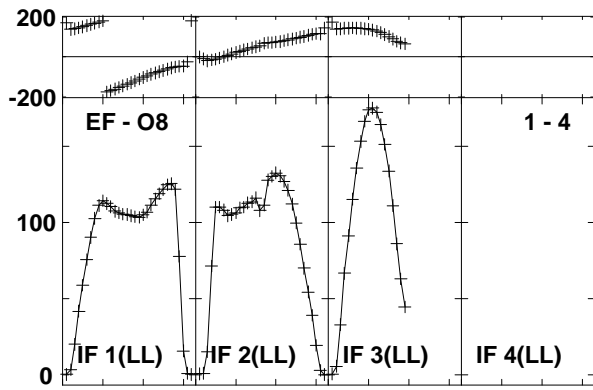
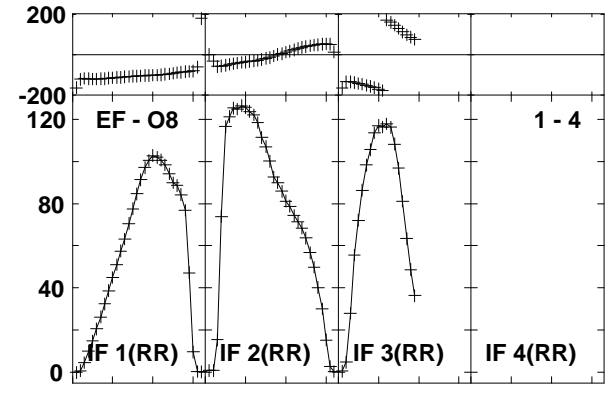
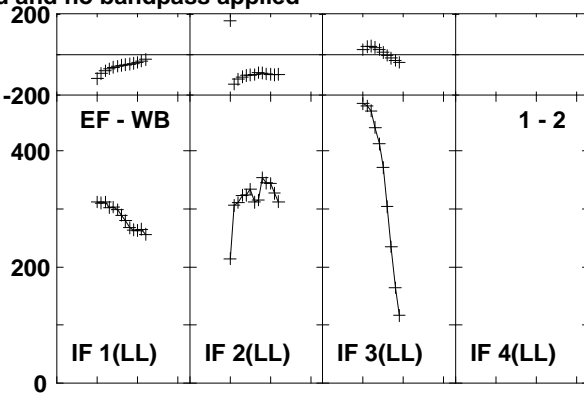
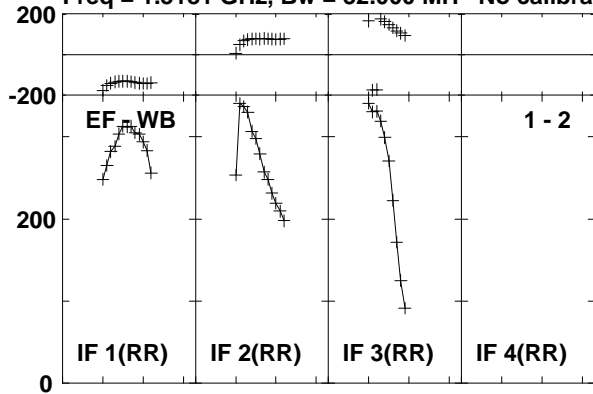

Lower frame: Milli Ampl Jy Top frame: Phas deg
Vector averaged cross-power spectrum Baseline: EF (01) - WB (02)
Timerange: 00/14:04:28 to 00/14:14:58

Plot file version 190 created 20-NOV-2015 13:44:03
 3C84 EO013 1.UVDATA.1
 Freq = 1.3181 GHz, Bw = 32.000 MH No calibration applied and no bandpass applied

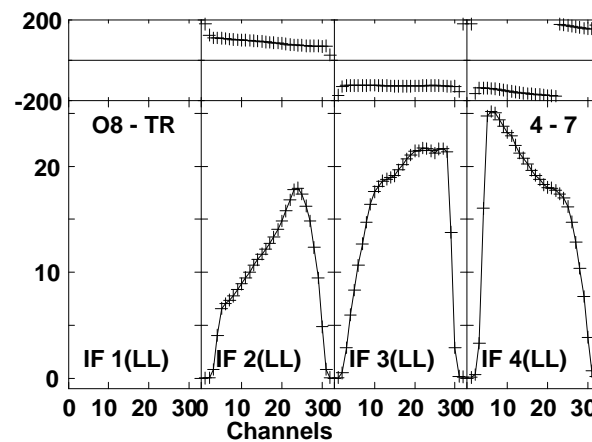
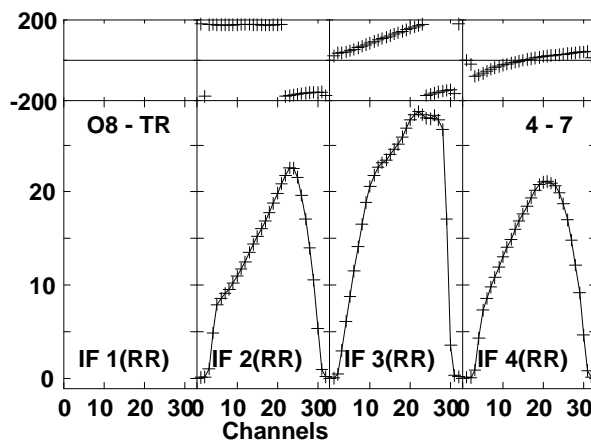
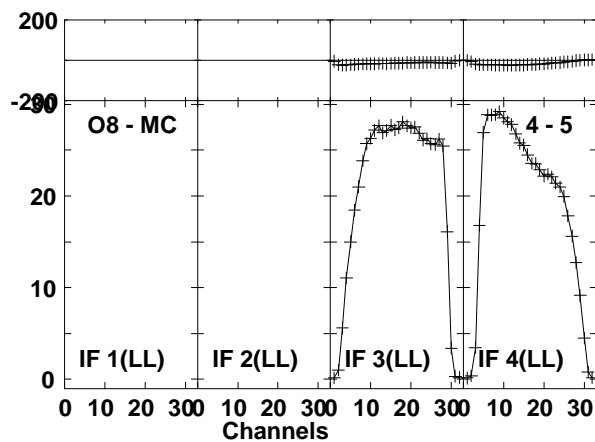
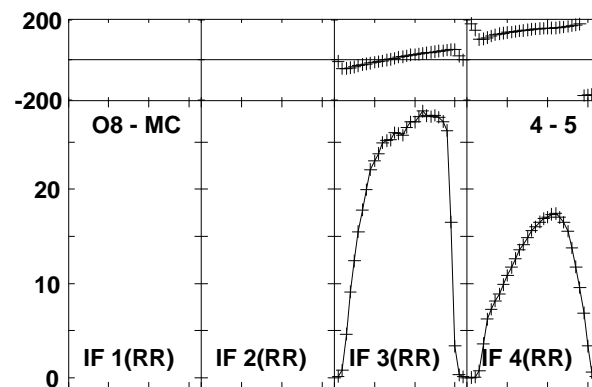
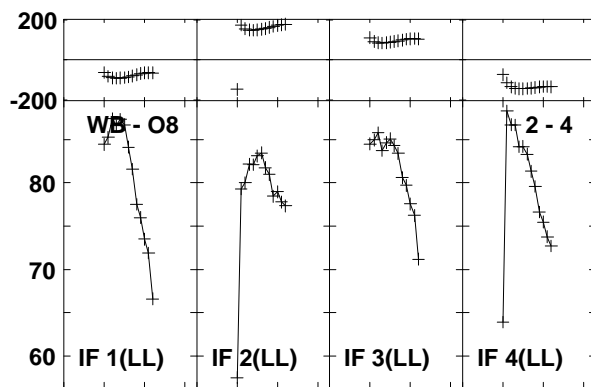
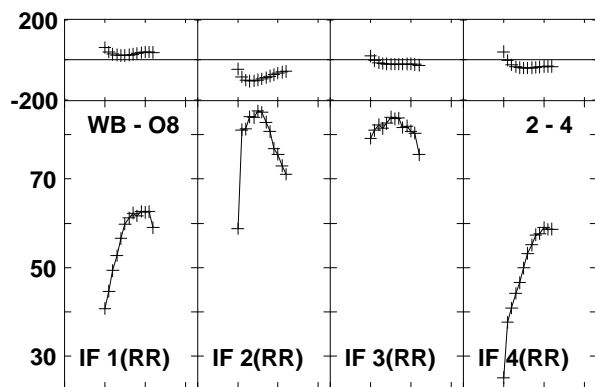
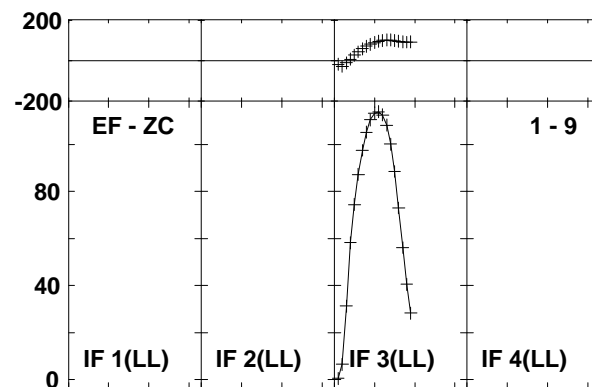
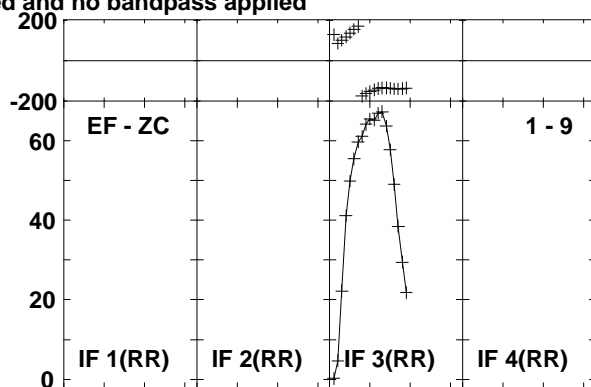
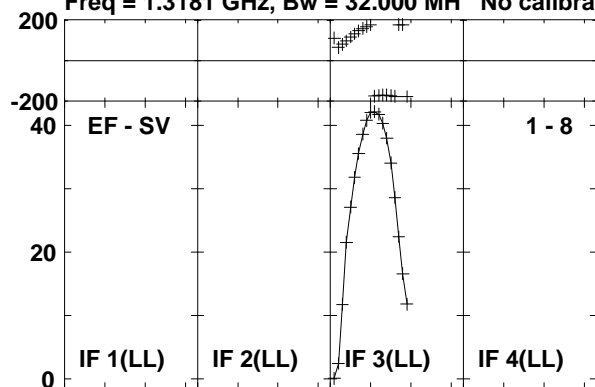

Lower frame: Milli Ampl Jy Top frame: Phas deg
 Vector averaged cross-power spectrum Baseline: EF (01) - SV (08)
 Timerange: 00/14:04:28 to 00/14:14:58

Plot file version 191 created 20-NOV-2015 13:44:03

3C84 EO013 1.UVDATA.1

Freq = 1.3181 GHz, Bw = 32.000 MH No calibration applied and no bandpass applied

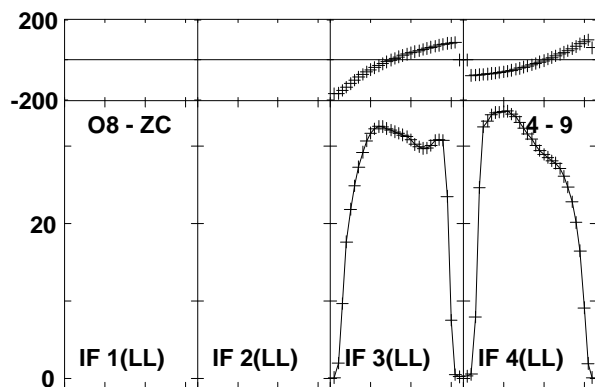
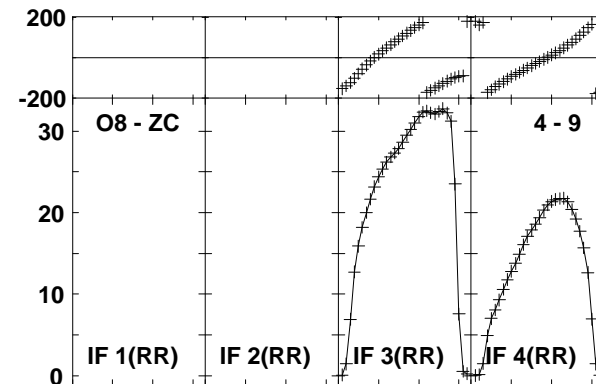
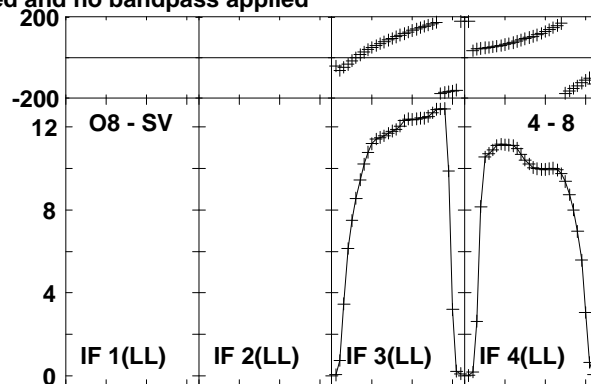
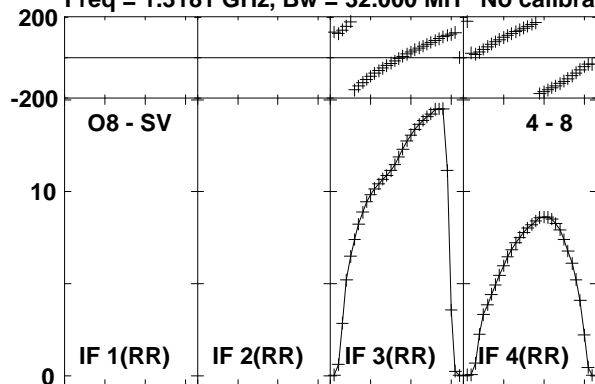

Lower frame: Milli Ampl Jy Top frame: Phas deg
Vector averaged cross-power spectrum Baseline: O8 (04) - SV (08)
Timerange: 00/14:04:28 to 00/14:14:58