

Plot file version 1 created 24-AUG-2010 08:14:21

3C286 EP064M.UVDATA.1

Freq = 4.9270 GHz, Bw = 16.000 MH Calibrated with CL # 3 and BP # 1 (BP mode 1)

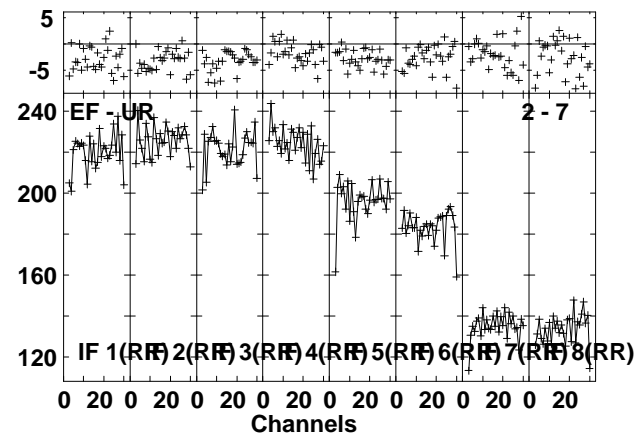
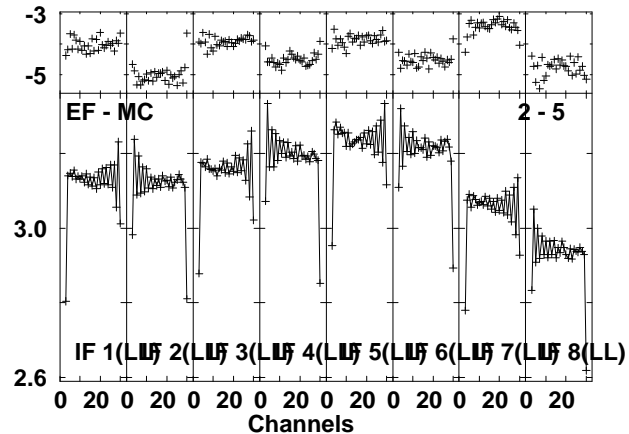
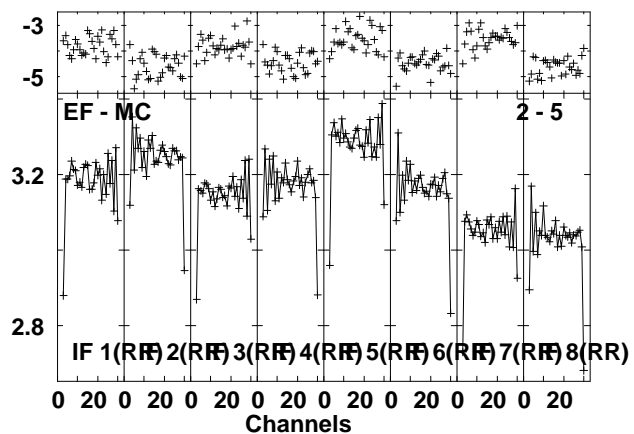
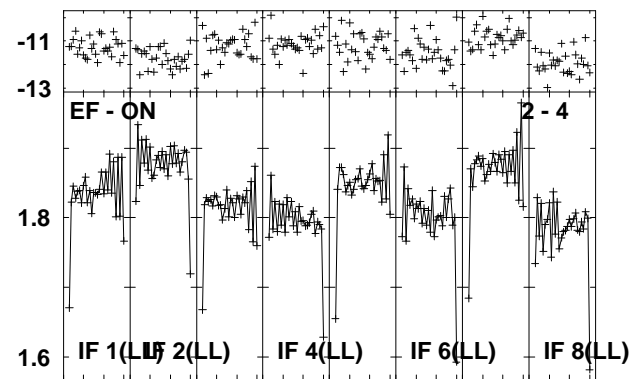
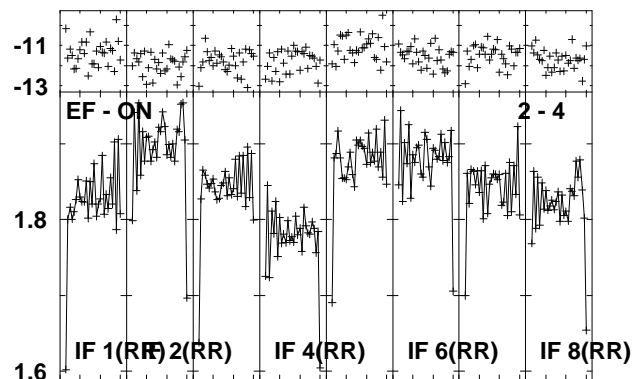
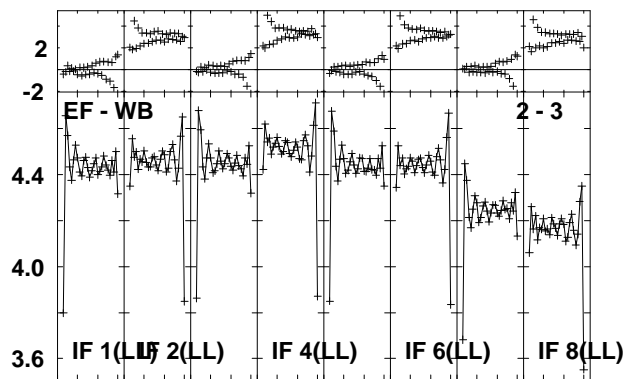
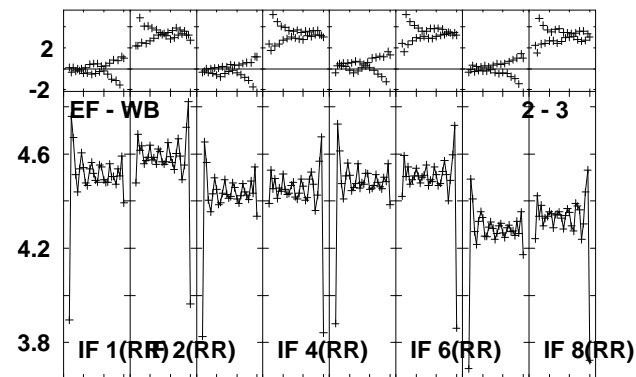
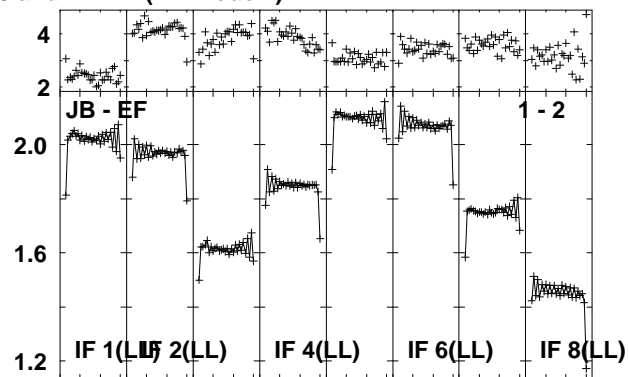
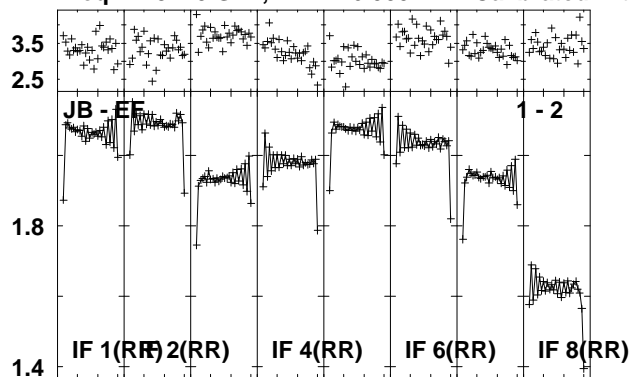

Lower frame: Ampl Jy Top frame: Phas deg  
Vector averaged cross-power spectrum Several baselines displayed  
Timerange: 00/22:00:01 to 00/22:04:59

Plot file version 2 created 24-AUG-2010 08:14:25

3C286 EP064M.UVDATA.1

Freq = 4.9270 GHz, Bw = 16.000 MH Calibrated with CL # 3 and BP # 1 (BP mode 1)

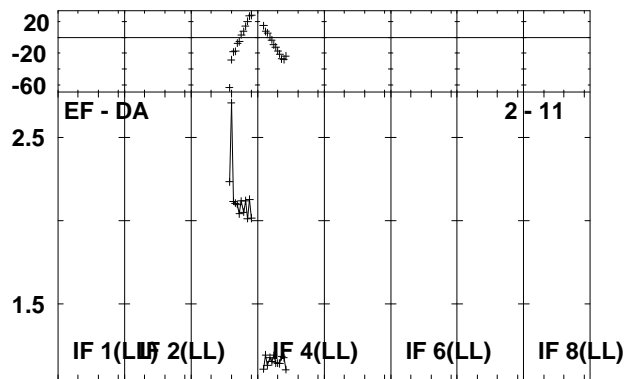
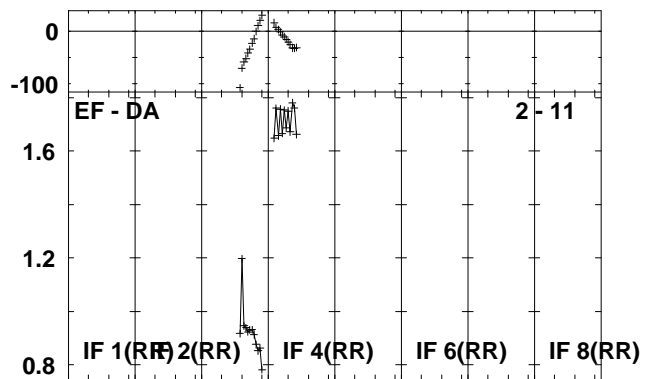
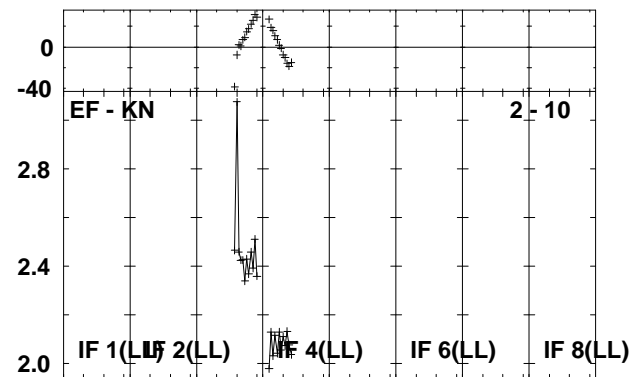
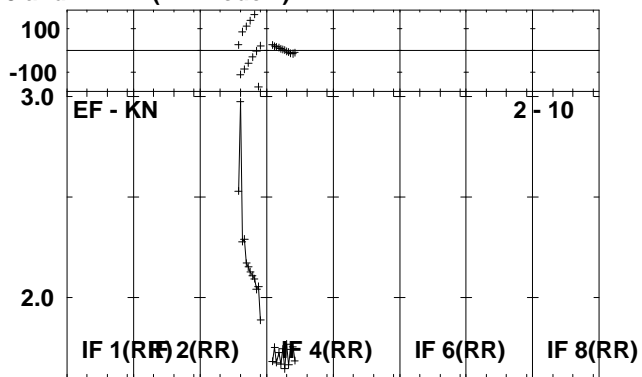
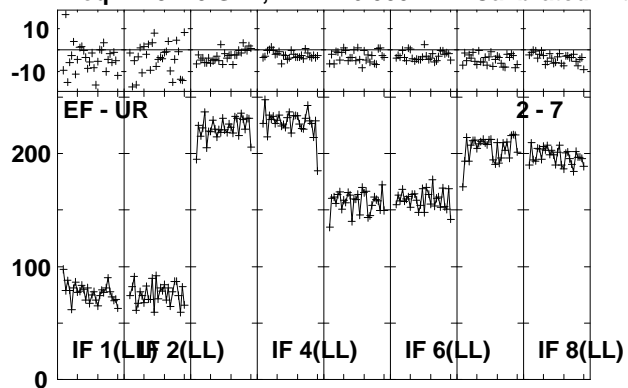

Lower frame: Milli Ampl Jy Top frame: Phas deg  
Vector averaged cross-power spectrum Several baselines displayed  
Timerange: 00/22:00:01 to 00/22:04:59

Plot file version 3 created 24-AUG-2010 08:14:31

3C345 EP064M.UVDATA.1

Freq = 4.9270 GHz, Bw = 16.000 MH Calibrated with CL # 3 and BP # 1 (BP mode 1)

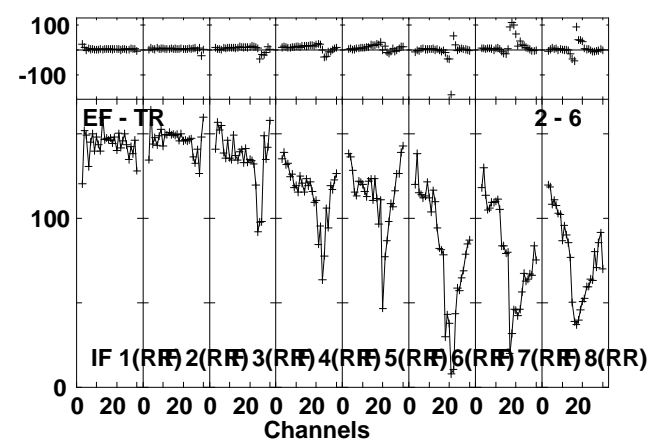
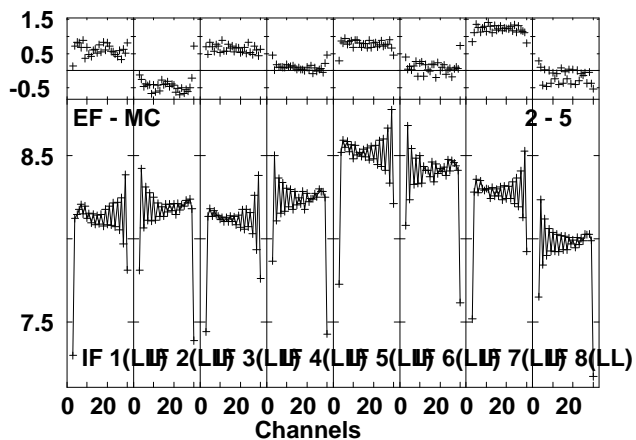
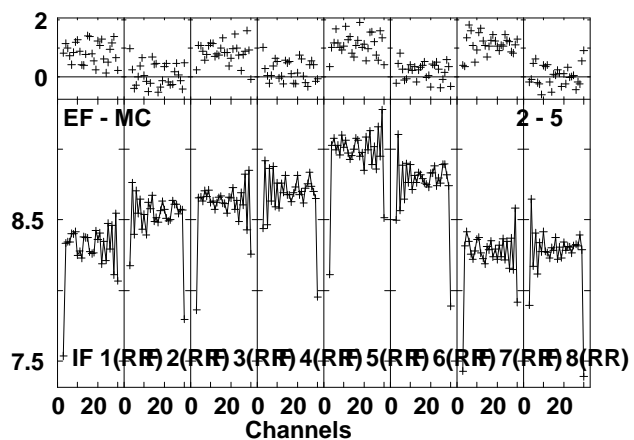
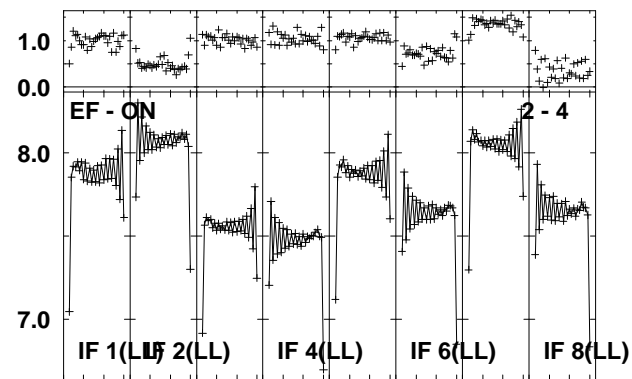
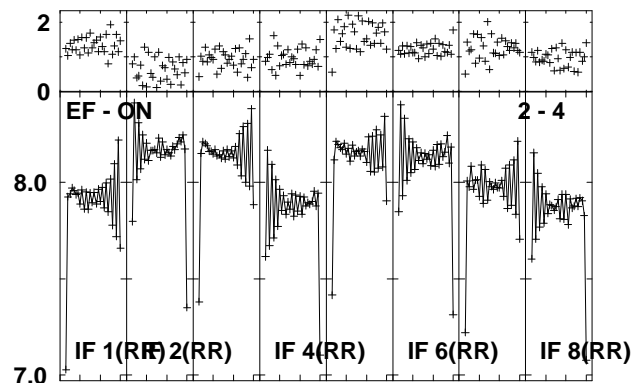
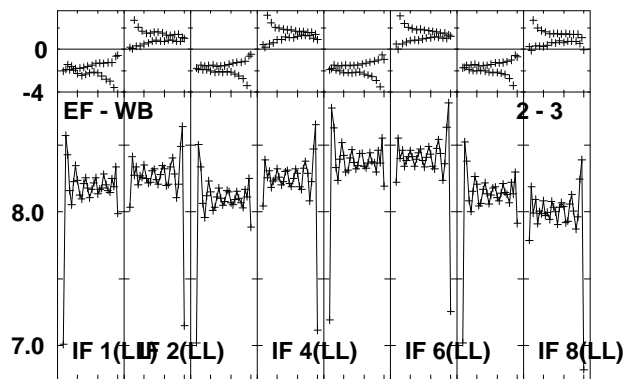
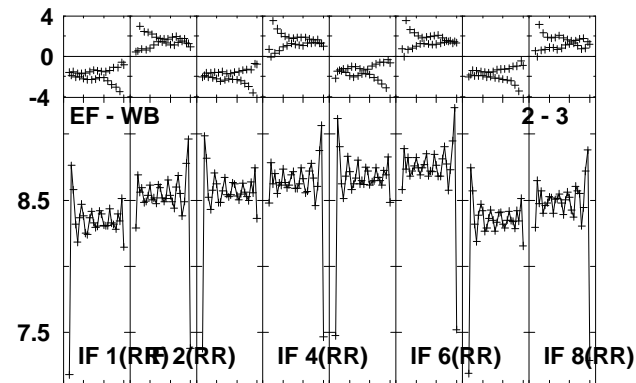
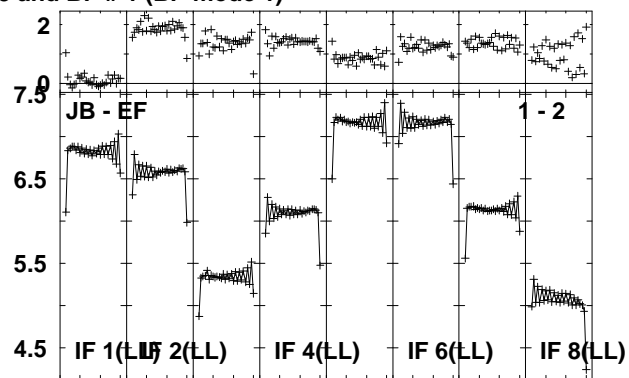
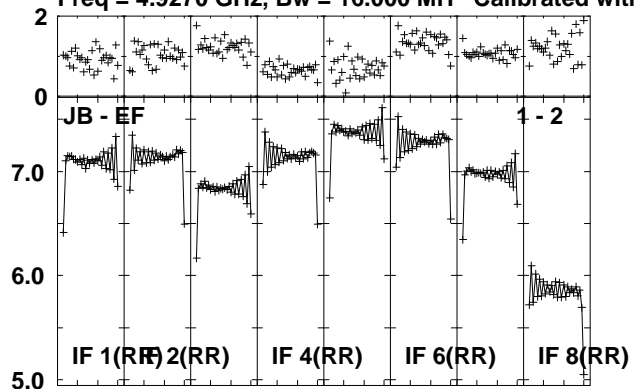

Lower frame: Ampl Jy Top frame: Phas deg  
Vector averaged cross-power spectrum Several baselines displayed  
Timerange: 00/22:06:01 to 00/22:19:59

Plot file version 4 created 24-AUG-2010 08:14:40

3C345 EP064M.UVDATA.1

Freq = 4.9270 GHz, Bw = 16.000 MH Calibrated with CL # 3 and BP # 1 (BP mode 1)

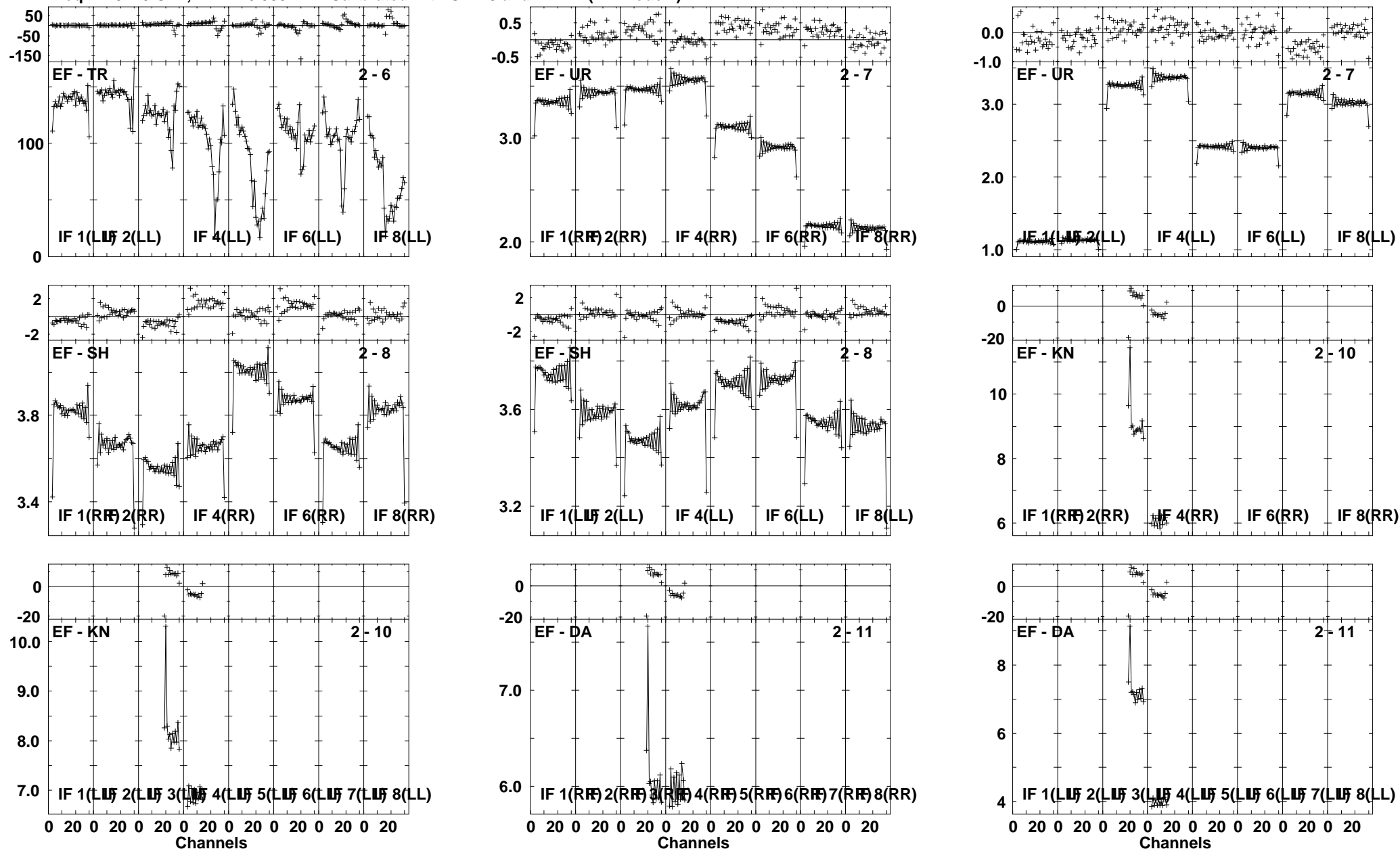

Lower frame: Milli Ampl Jy Top frame: Phas deg  
Vector averaged cross-power spectrum Several baselines displayed  
Timerange: 00/22:06:01 to 00/22:19:59

Plot file version 5 created 24-AUG-2010 08:14:53

J1941-05 EP064M.UVDATA.1

Freq = 4.9270 GHz, Bw = 16.000 MH Calibrated with CL # 3 and BP # 1 (BP mode 1)

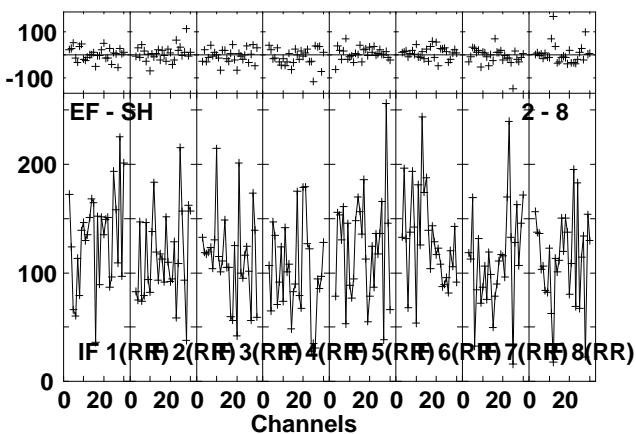
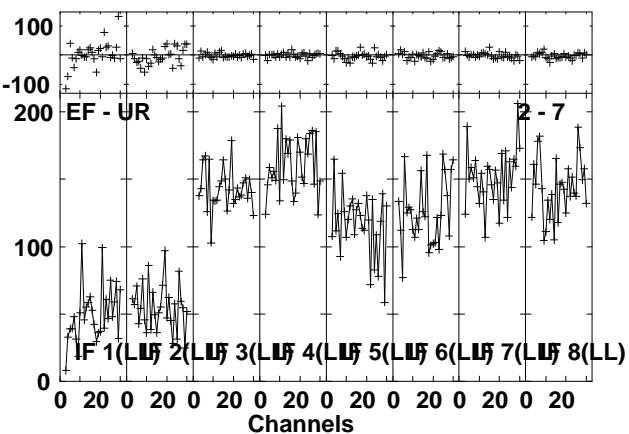
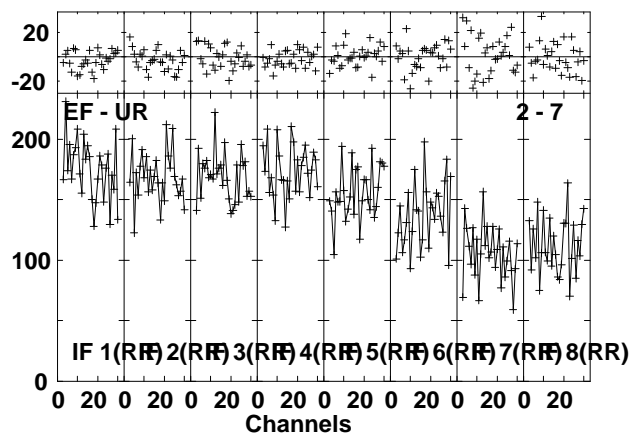
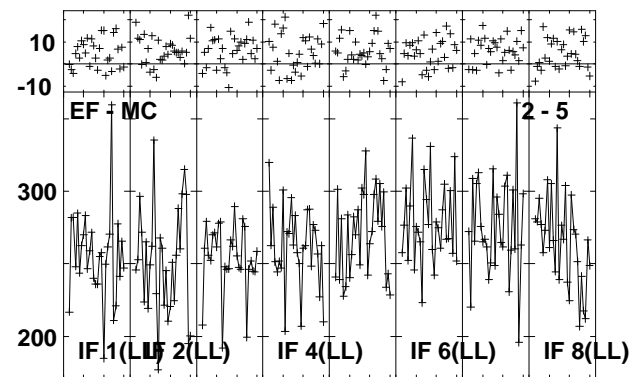
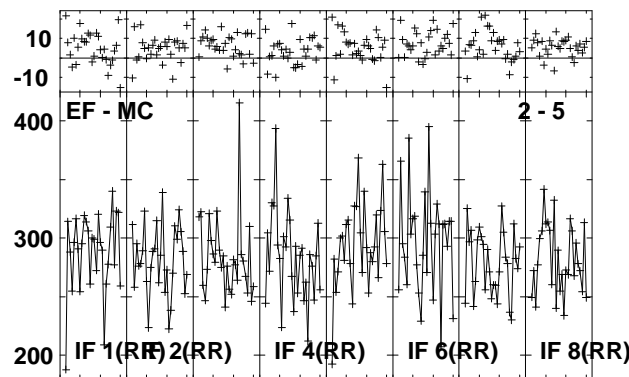
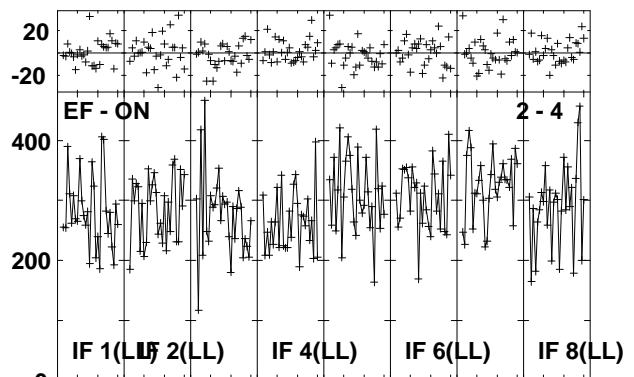
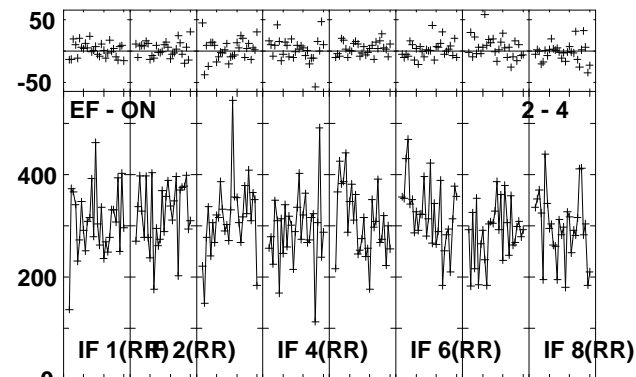
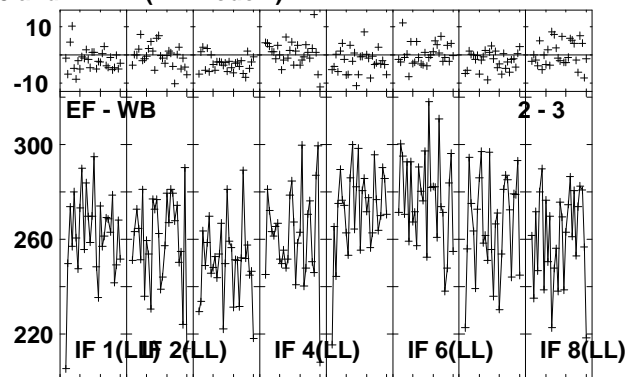
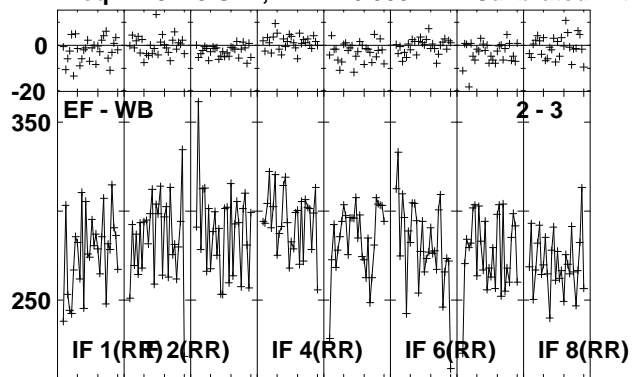

Lower frame: Milli Ampl Jy Top frame: Phas deg  
Vector averaged cross-power spectrum Several baselines displayed  
Timerange: 00/22:26:01 to 00/22:27:29

Plot file version 6 created 24-AUG-2010 08:14:54

J1941-05 EP064M.UVDATA.1

Freq = 4.9270 GHz, Bw = 16.000 MH Calibrated with CL # 3 and BP # 1 (BP mode 1)

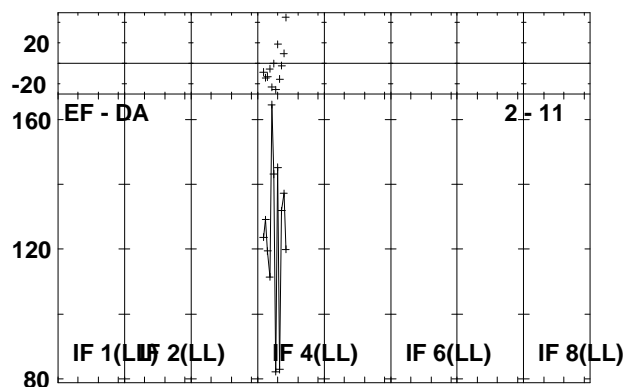
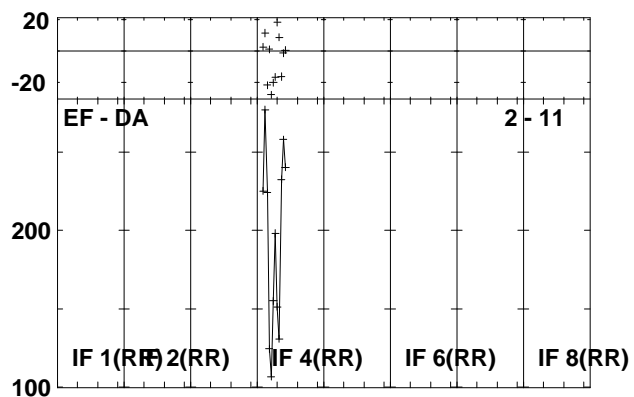
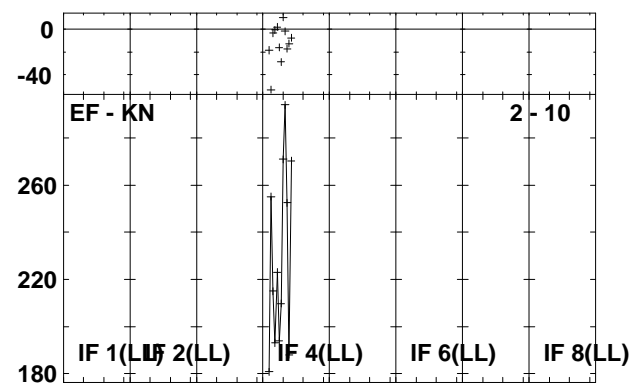
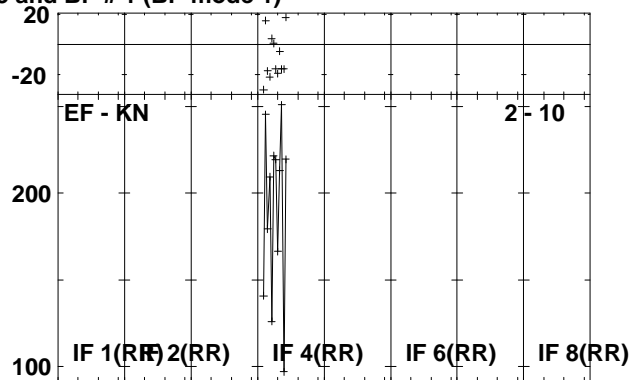
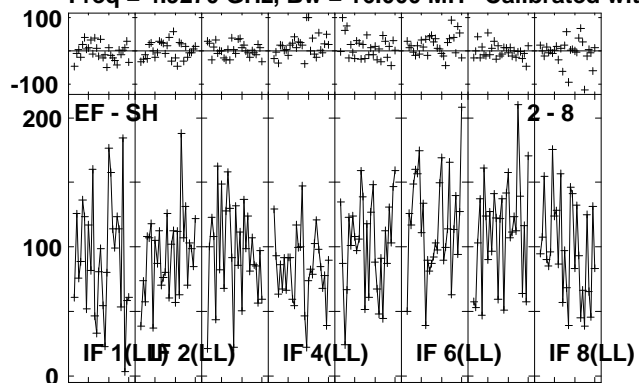

Lower frame: Milli Ampl Jy Top frame: Phas deg  
Vector averaged cross-power spectrum Several baselines displayed  
Timerange: 00/22:26:01 to 00/22:27:29

Plot file version 7 created 24-AUG-2010 08:14:55

IRAS1929 EP064M.UVDATA.1

Freq = 4.9270 GHz, Bw = 16.000 MH Calibrated with CL # 3 and BP # 1 (BP mode 1)

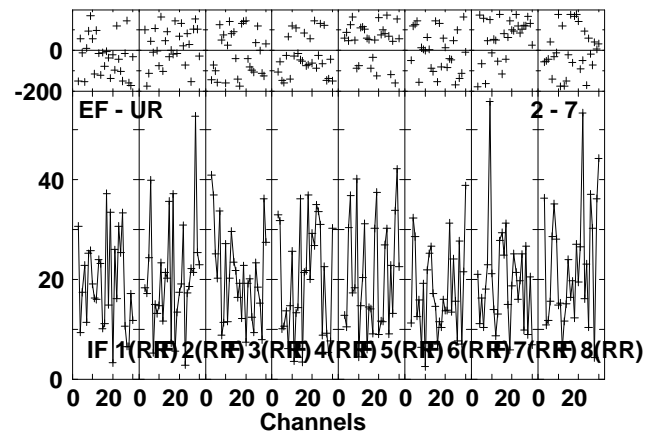
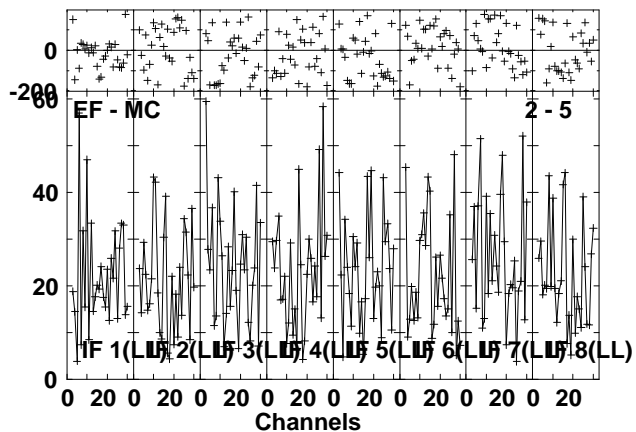
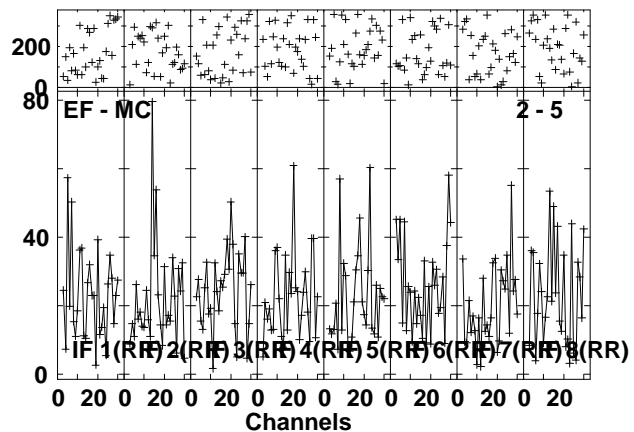
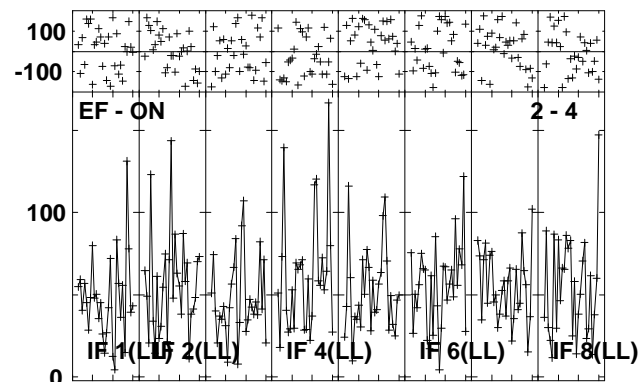
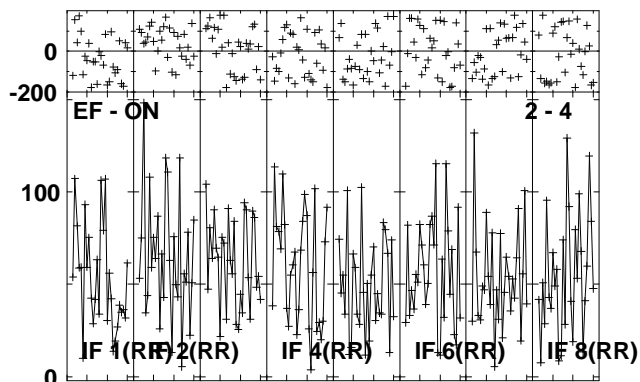
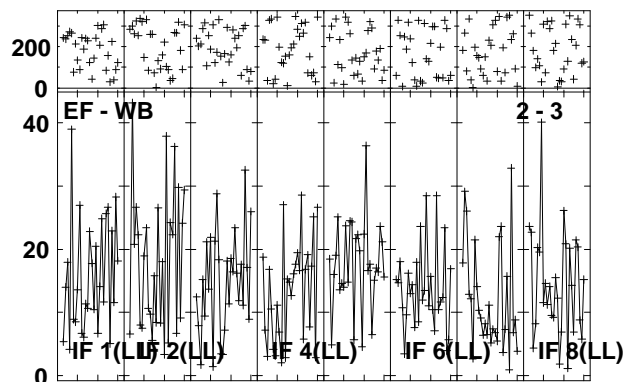
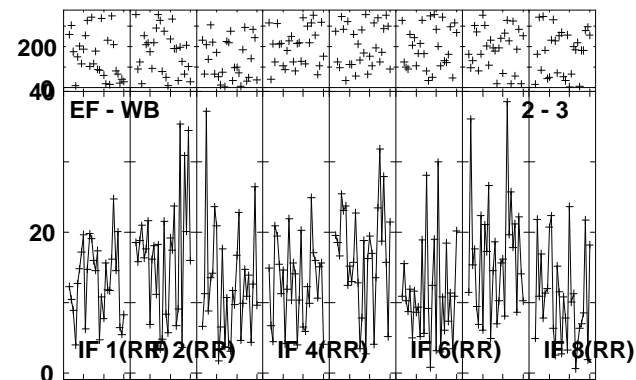
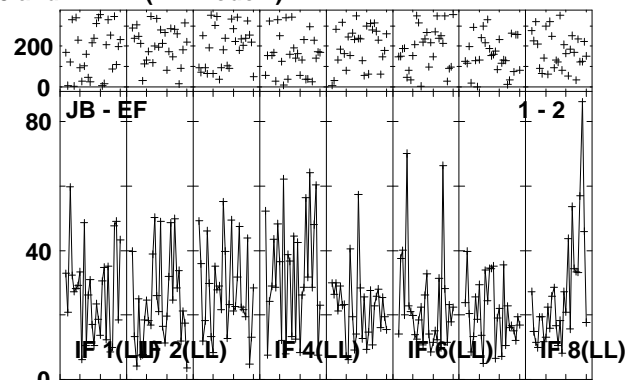
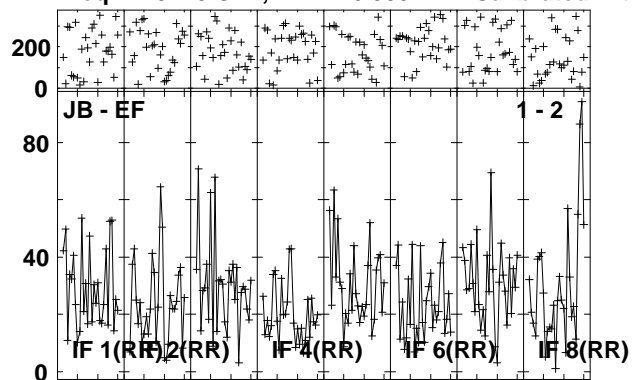

Lower frame: Milli Ampl Jy Top frame: Phas deg  
Vector averaged cross-power spectrum Several baselines displayed  
Timerange: 00/22:27:31 to 00/22:30:59





Plot file version 9 created 24-AUG-2010 08:15:01

J1941-05 EP064M.UVDATA.1

Freq = 4.9270 GHz, Bw = 16.000 MH Calibrated with CL # 3 and BP # 1 (BP mode 1)

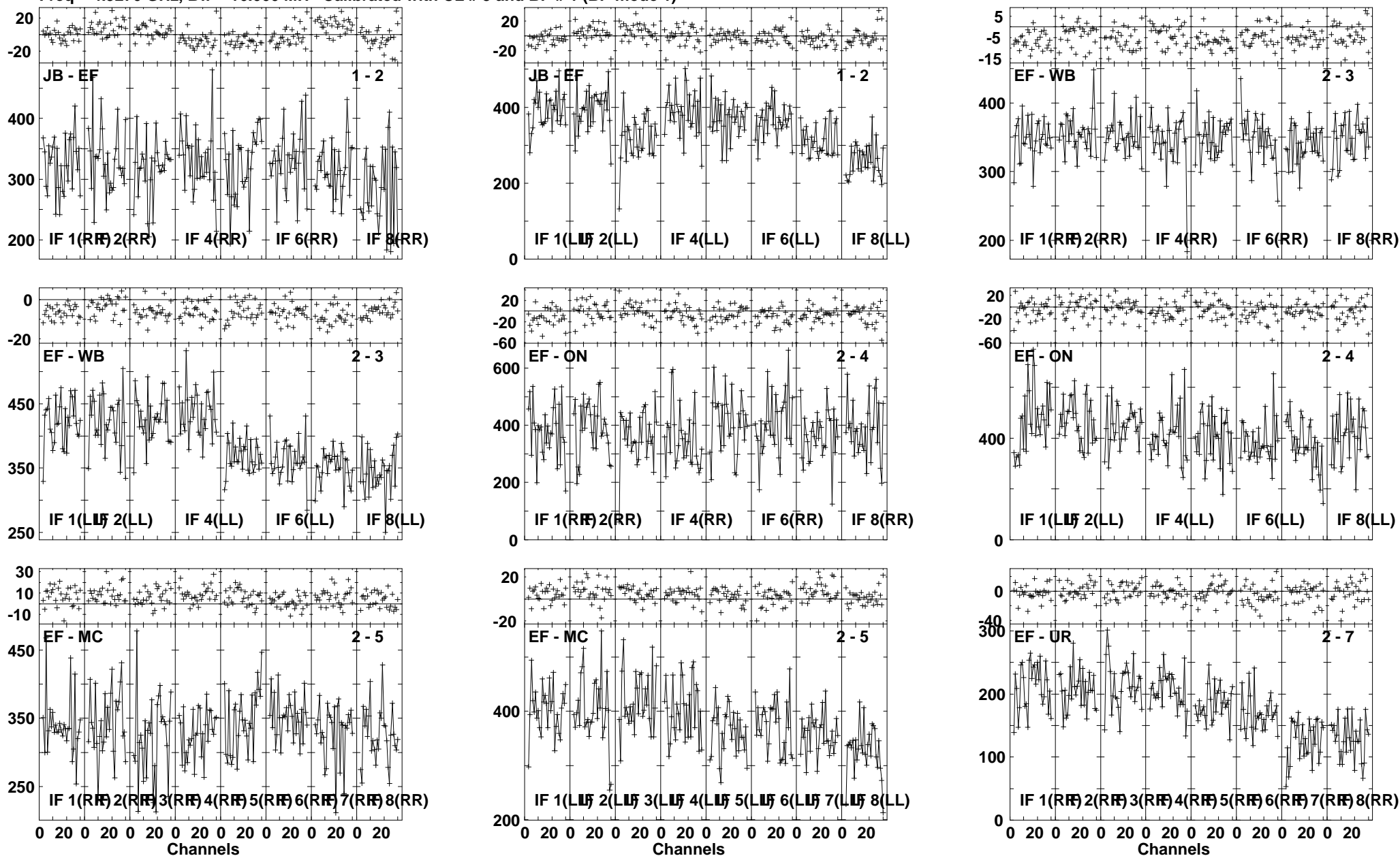

Lower frame: Milli Ampl Jy Top frame: Phas deg  
Vector averaged cross-power spectrum Several baselines displayed  
Timerange: 00/22:31:01 to 00/22:32:29

Plot file version 10 created 24-AUG-2010 08:15:03

J1941-05 EP064M.UVDATA.1

Freq = 4.9270 GHz, Bw = 16.000 MH Calibrated with CL # 3 and BP # 1 (BP mode 1)

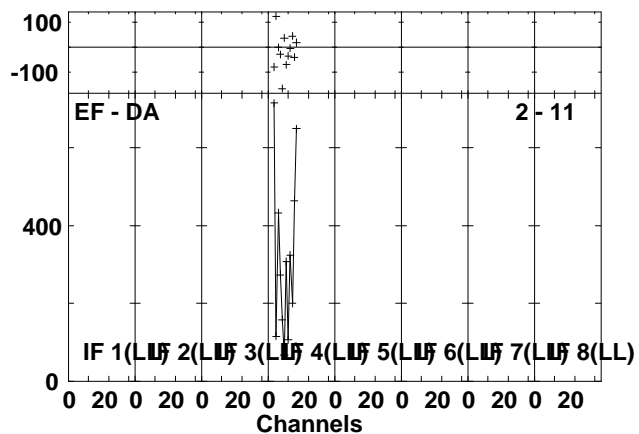
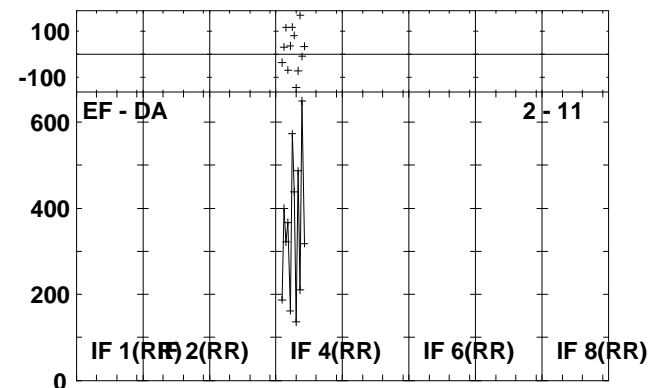
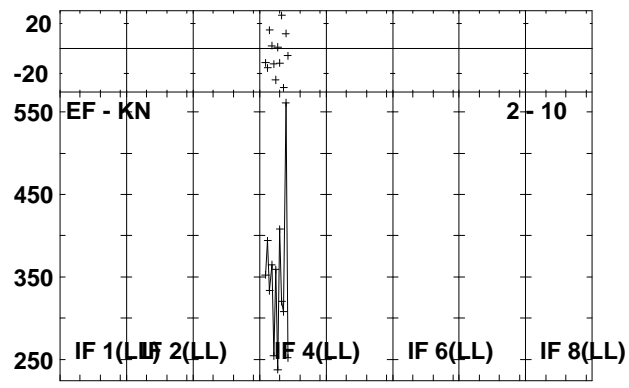
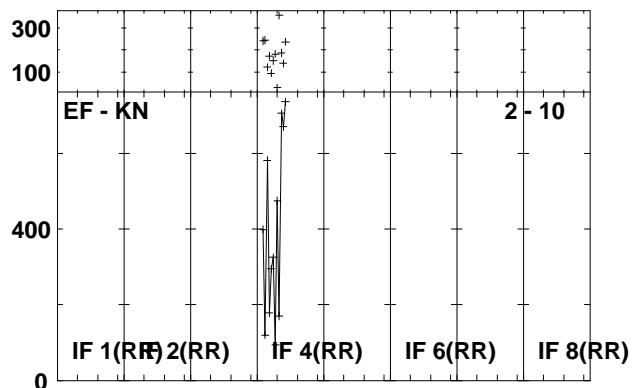
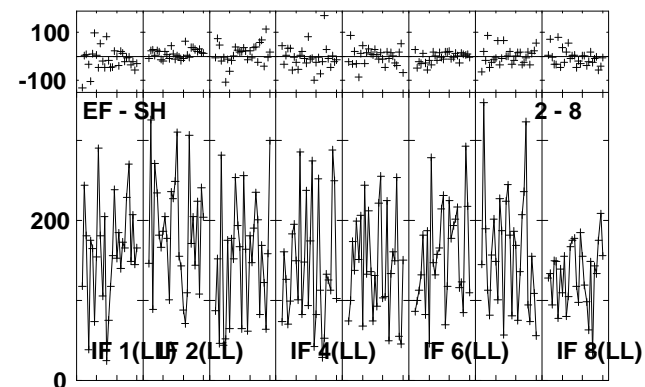
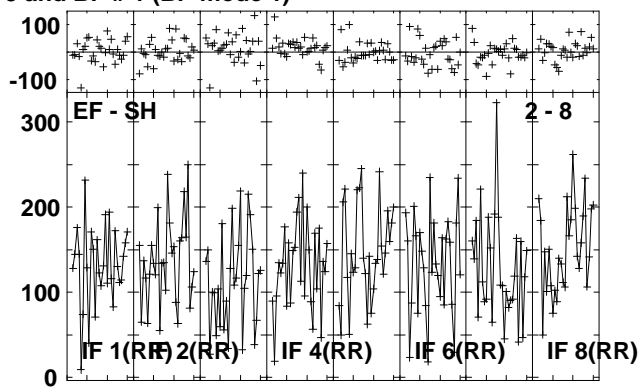
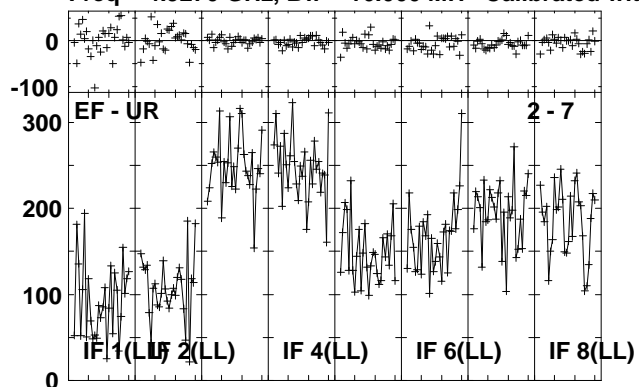

Lower frame: Milli Ampl Jy Top frame: Phas deg  
Vector averaged cross-power spectrum Several baselines displayed  
Timerange: 00/22:31:01 to 00/22:32:29

Plot file version 11 created 24-AUG-2010 08:15:04

IRAS1929 EP064M.UVDATA.1

Freq = 4.9270 GHz, Bw = 16.000 MH Calibrated with CL # 3 and BP # 1 (BP mode 1)

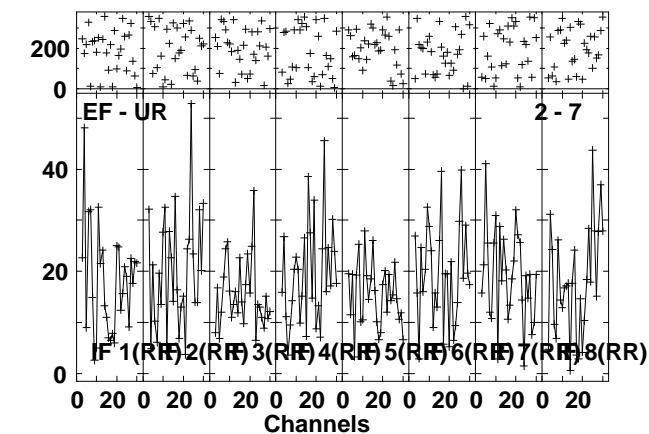
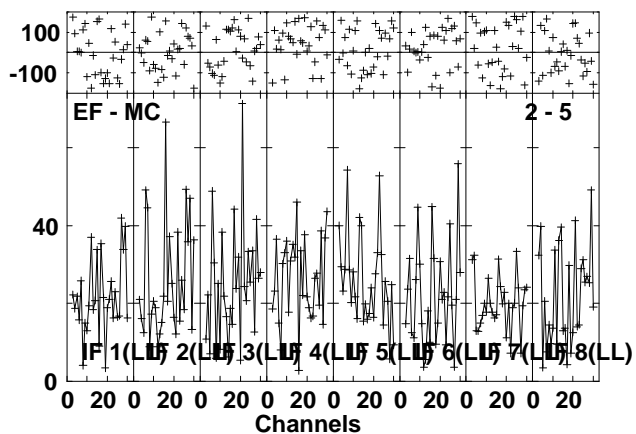
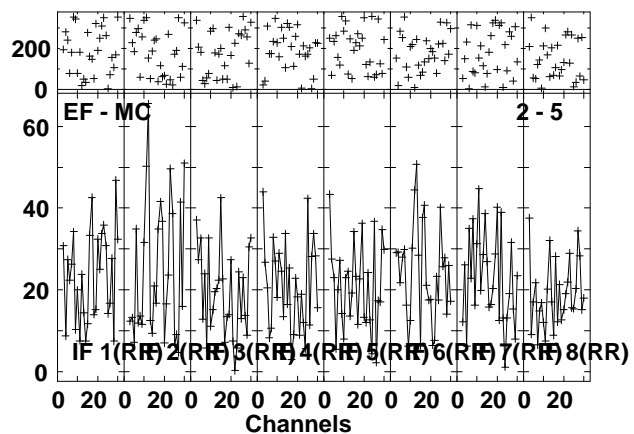
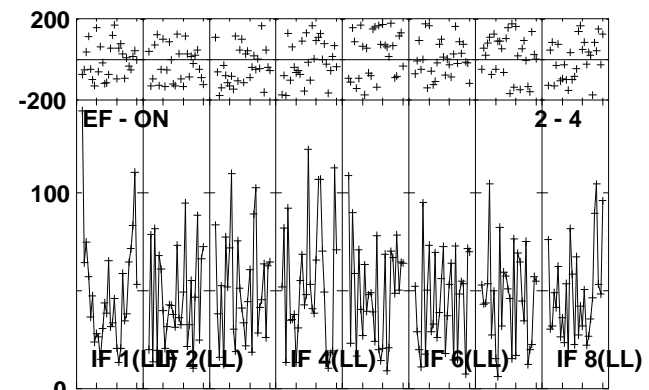
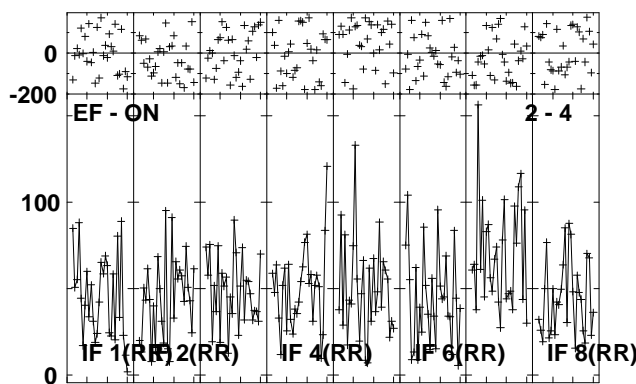
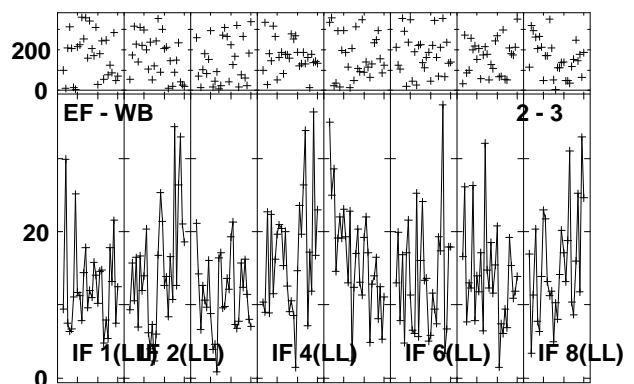
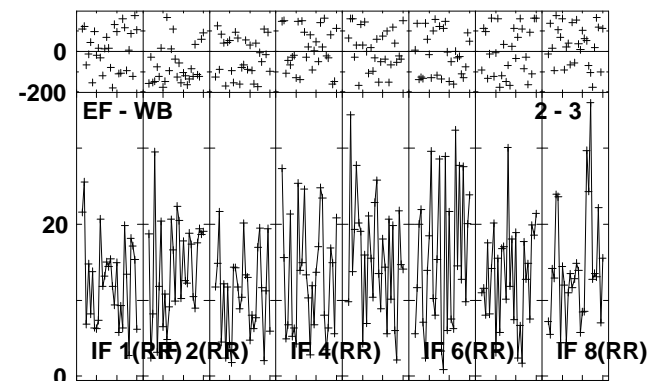
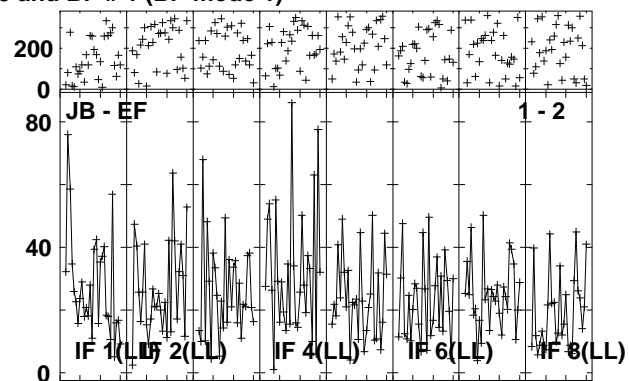
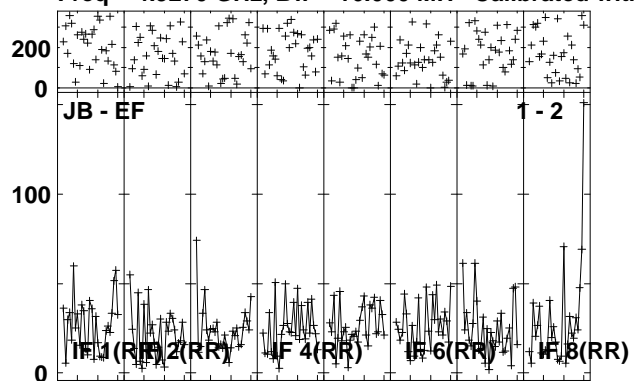

Lower frame: Milli Ampl Jy Top frame: Phas deg  
Vector averaged cross-power spectrum Several baselines displayed  
Timerange: 00/22:32:31 to 00/22:35:59

Plot file version 12 created 24-AUG-2010 08:15:07

IRAS1929 EP064M.UVDATA.1

Freq = 4.9270 GHz, Bw = 16.000 MH Calibrated with CL # 3 and BP # 1 (BP mode 1)

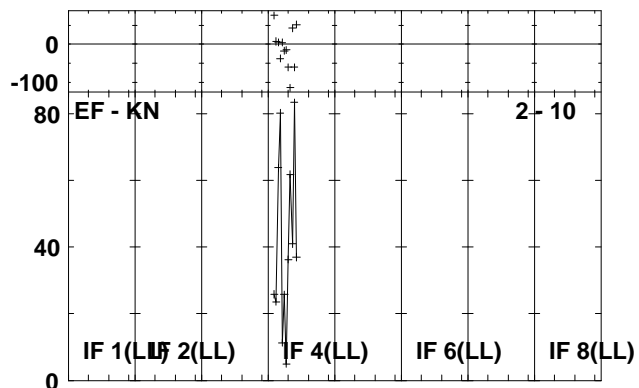
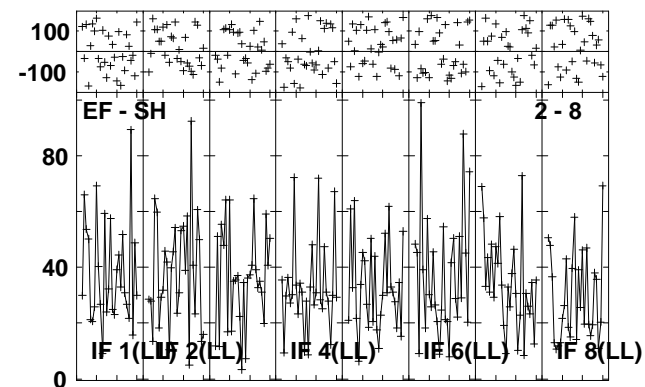
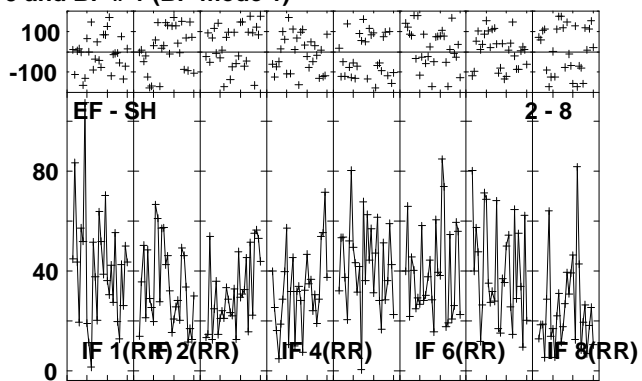
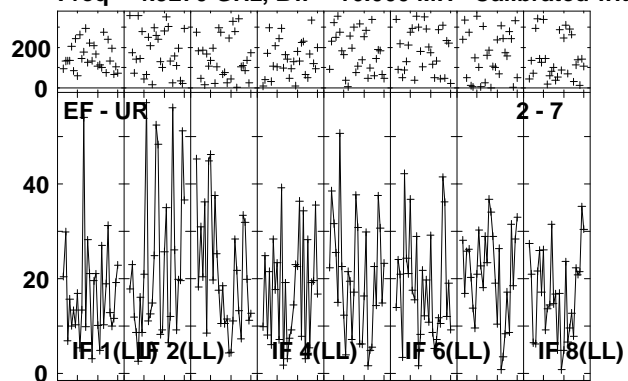

Lower frame: Milli Ampl Jy Top frame: Phas deg  
Vector averaged cross-power spectrum Several baselines displayed  
Timerange: 00:22:32:31 to 00:22:35:59

Plot file version 13 created 24-AUG-2010 08:15:10

J1941-05 EP064M.UVDATA.1

Freq = 4.9270 GHz, Bw = 16.000 MH Calibrated with CL # 3 and BP # 1 (BP mode 1)

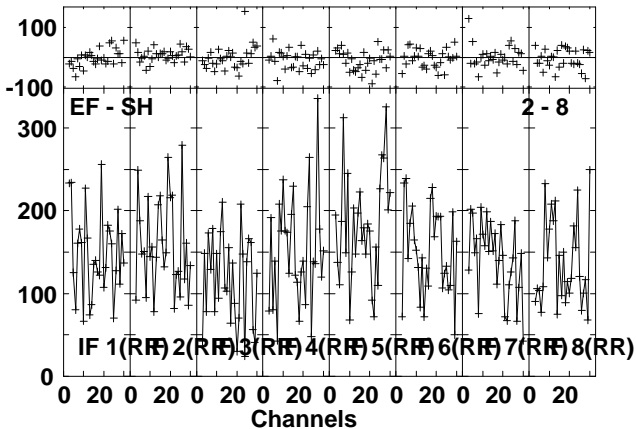
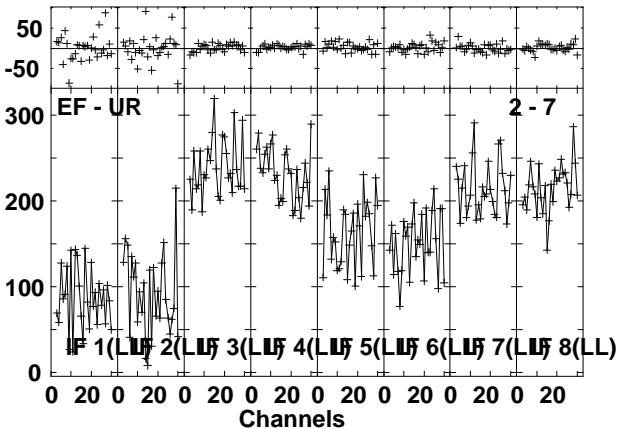
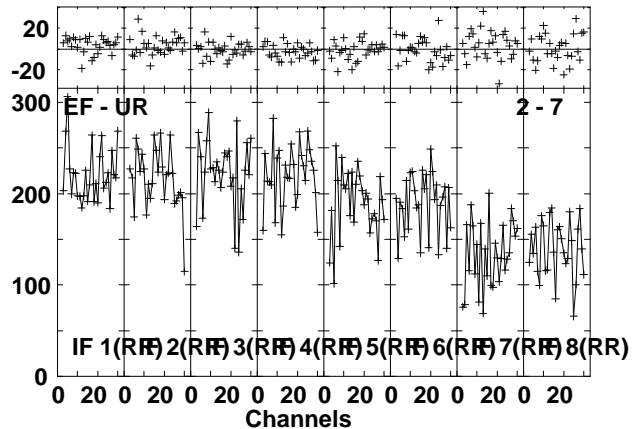
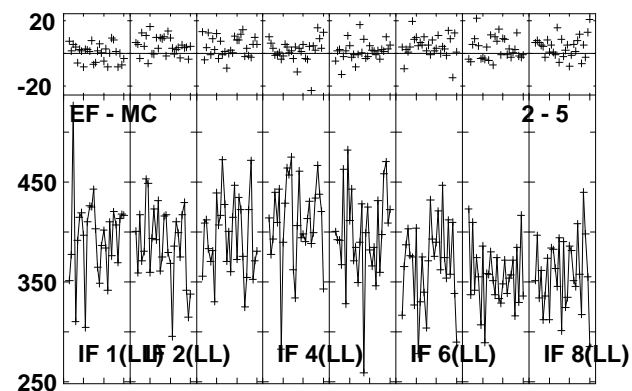
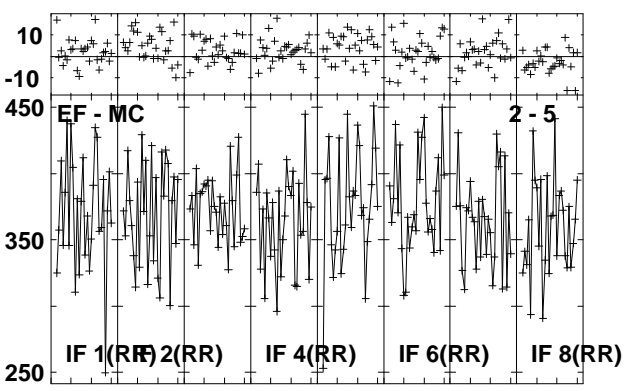
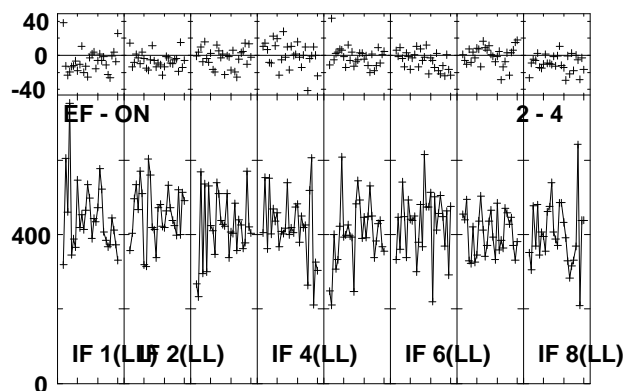
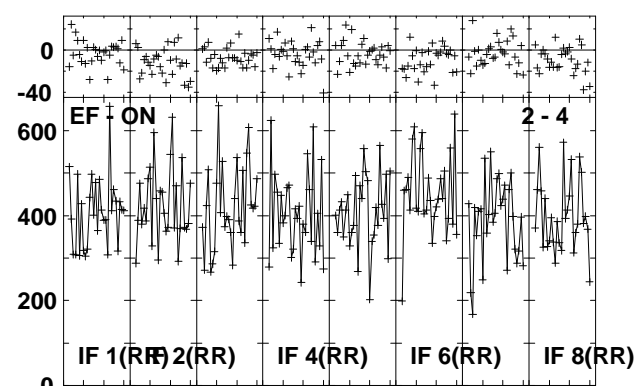
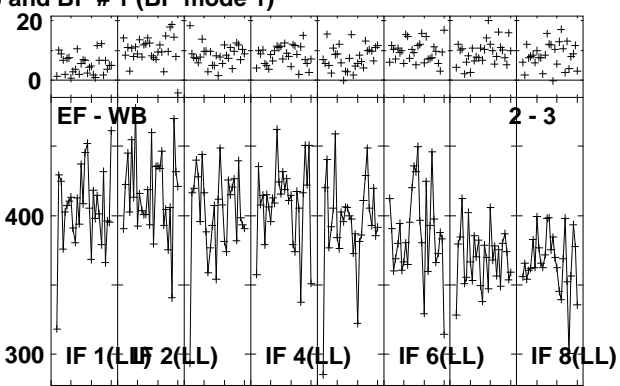
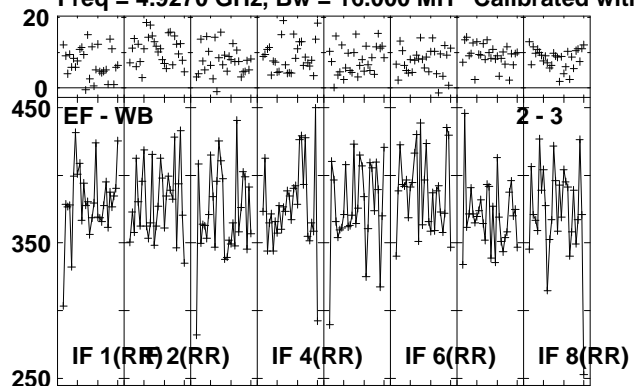

Lower frame: Milli Ampl Jy Top frame: Phas deg  
Vector averaged cross-power spectrum Several baselines displayed  
Timerange: 00:22:36:01 to 00:22:37:29

Plot file version 14 created 24-AUG-2010 08:15:12

J1941-05 EP064M.UVDATA.1

Freq = 4.9270 GHz, Bw = 16.000 MH Calibrated with CL # 3 and BP # 1 (BP mode 1)

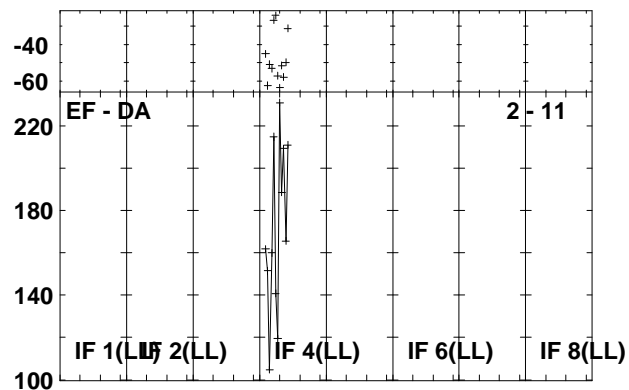
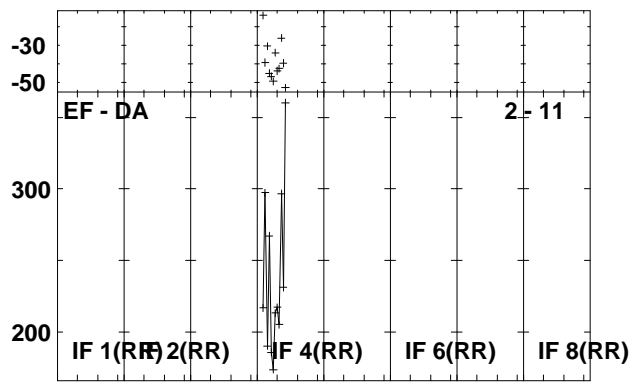
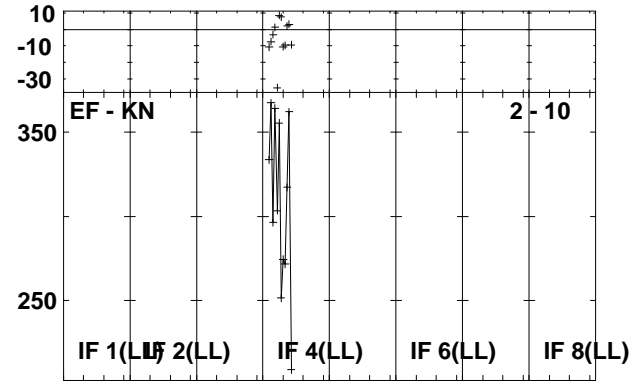
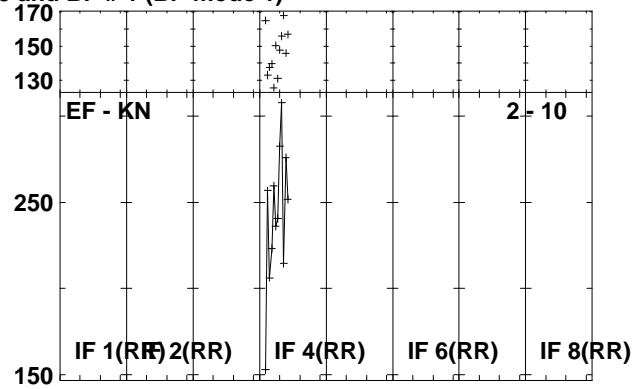
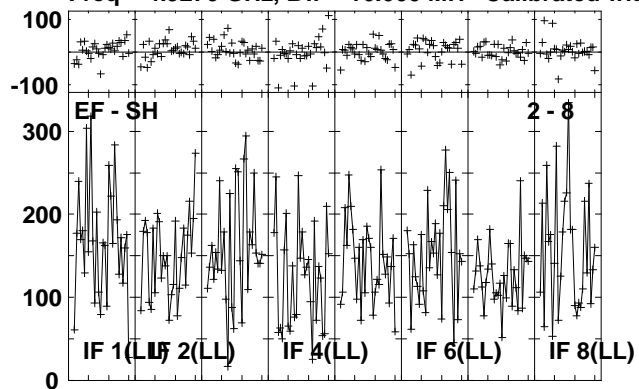

Lower frame: Milli Ampl Jy Top frame: Phas deg  
Vector averaged cross-power spectrum Several baselines displayed  
Timerange: 00/22:36:01 to 00/22:37:29

Plot file version 15 created 24-AUG-2010 08:15:13

IRAS1929 EP064M.UVDATA.1

Freq = 4.9270 GHz, Bw = 16.000 MH Calibrated with CL # 3 and BP # 1 (BP mode 1)

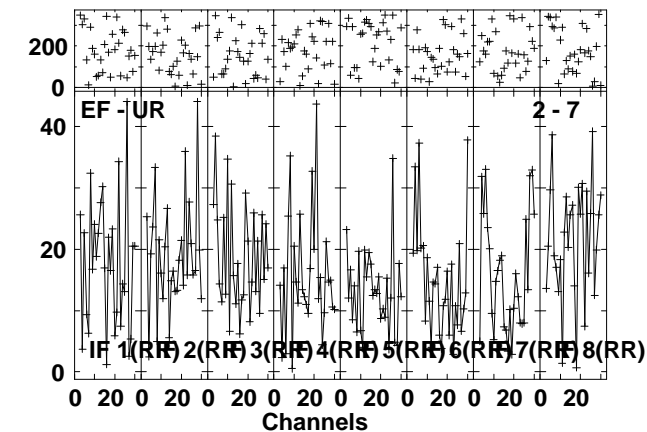
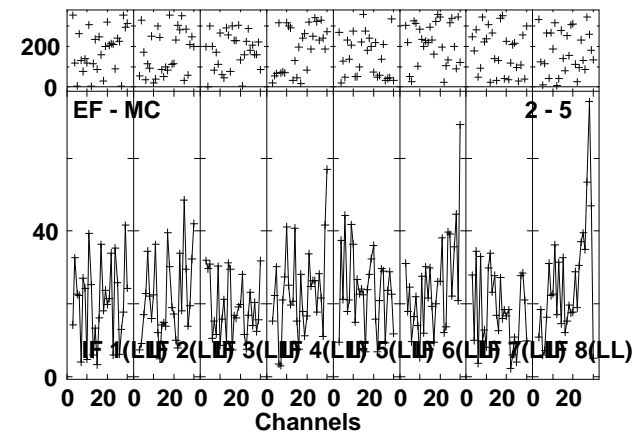
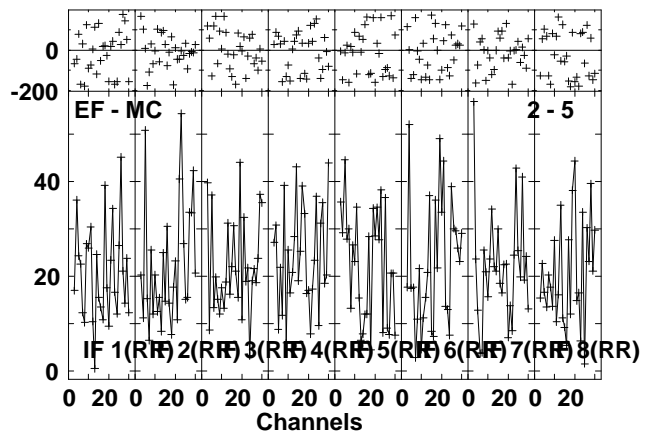
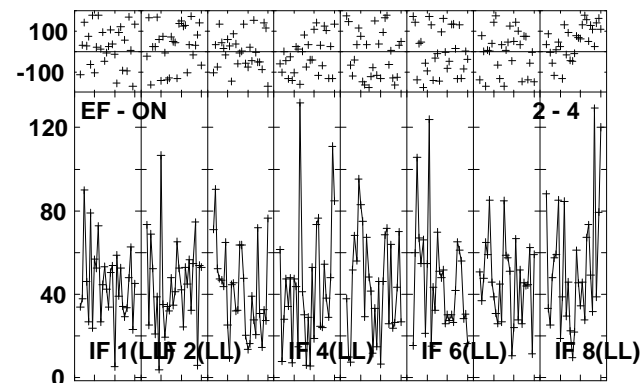
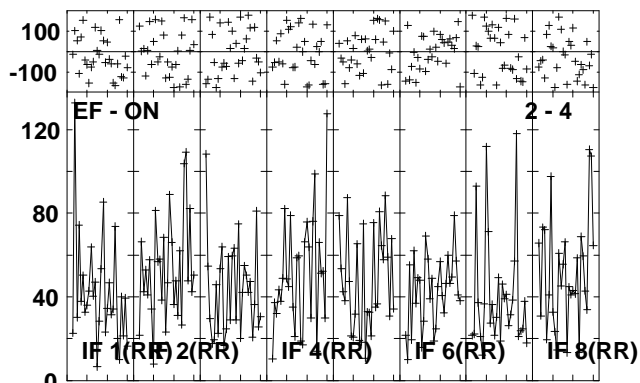
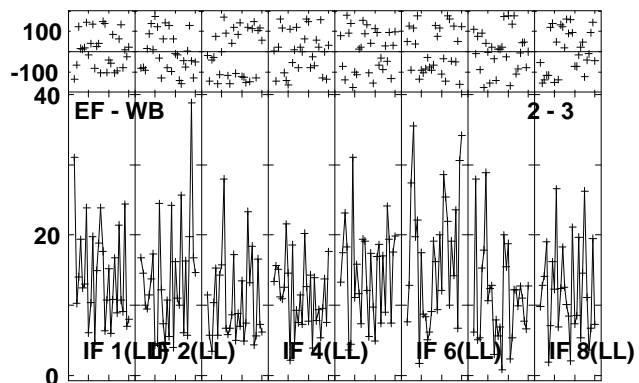
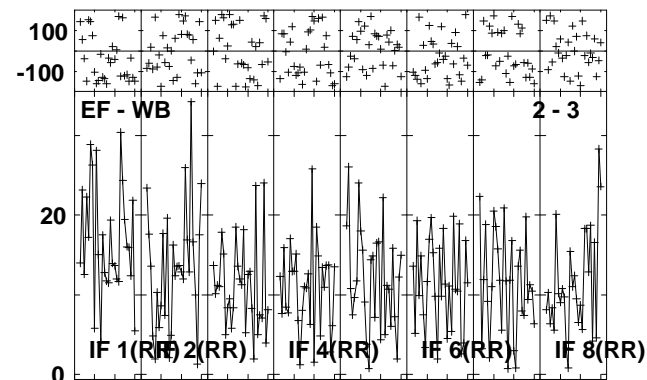
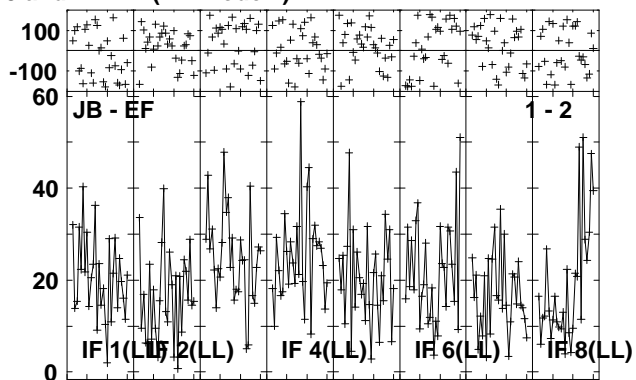
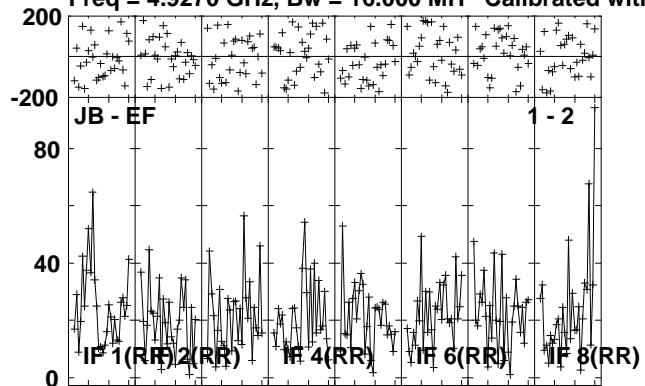

Lower frame: Milli Ampl Jy Top frame: Phas deg  
Vector averaged cross-power spectrum Several baselines displayed  
Timerange: 00/22:37:31 to 00/22:40:59

Plot file version 16 created 24-AUG-2010 08:15:17

IRAS1929 EP064M.UVDATA.1

Freq = 4.9270 GHz, Bw = 16.000 MH Calibrated with CL # 3 and BP # 1 (BP mode 1)

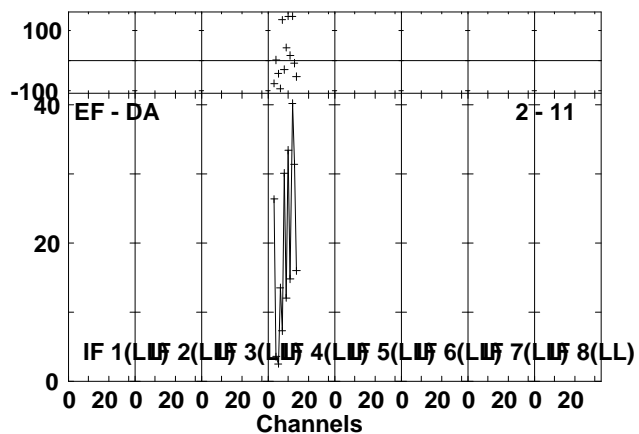
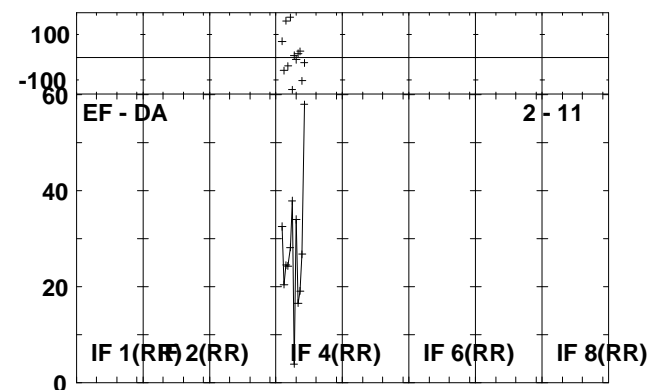
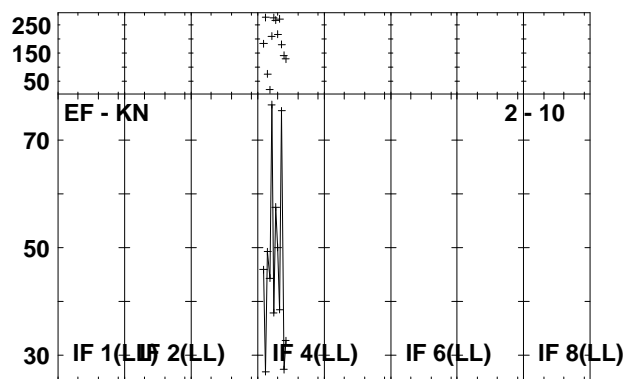
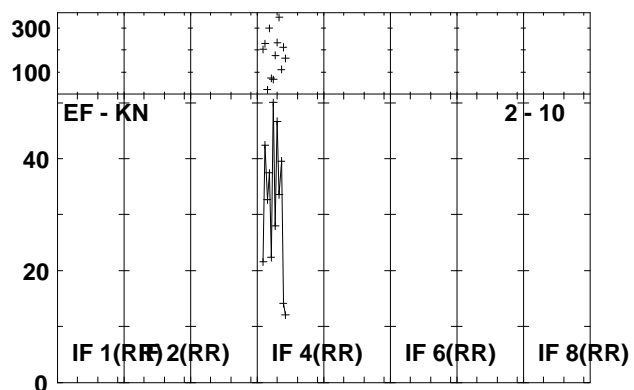
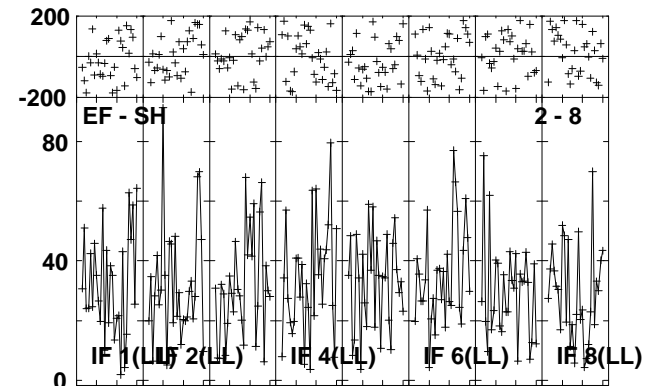
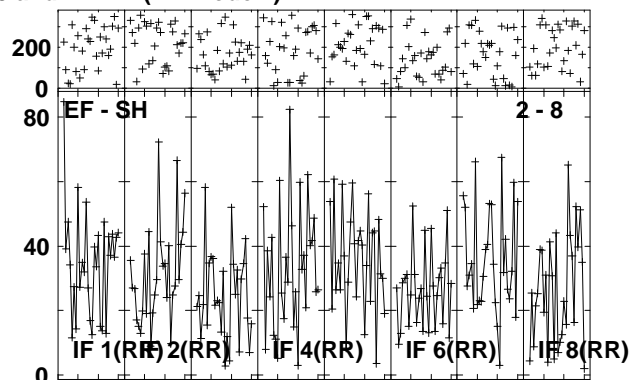
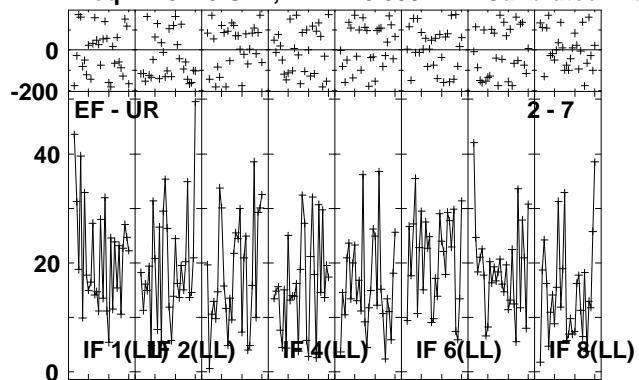

Lower frame: Milli Ampl Jy Top frame: Phas deg  
Vector averaged cross-power spectrum Several baselines displayed  
Timerange: 00/22:37:31 to 00/22:40:59



Plot file version 17 created 24-AUG-2010 08:15:20

J1941-05 EP064M.UVDATA.1

Freq = 4.9270 GHz, Bw = 16.000 MH Calibrated with CL # 3 and BP # 1 (BP mode 1)

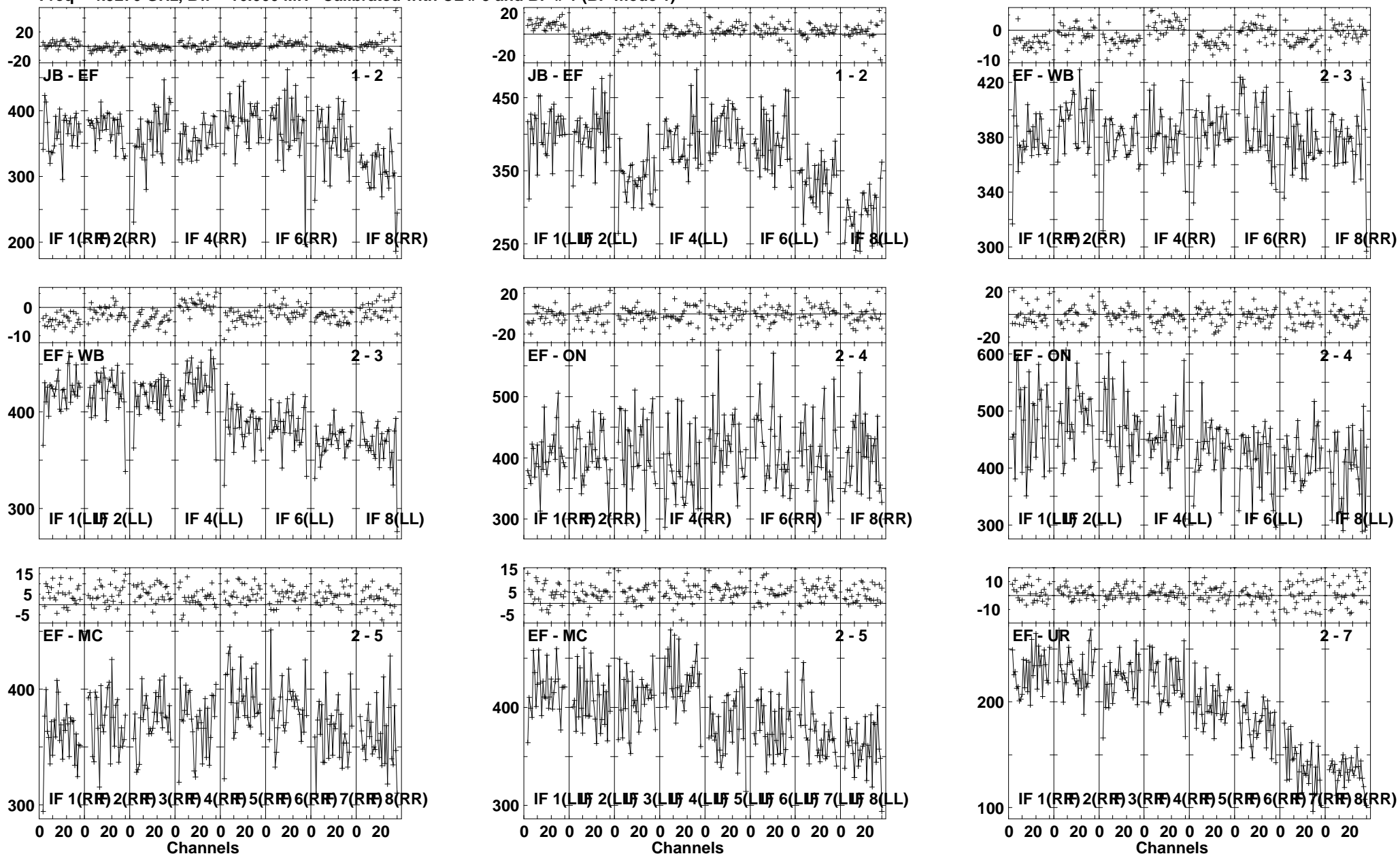

Plot file version 18 created 24-AUG-2010 08:15:21

J1941-05 EP064M.UVDATA.1

Freq = 4.9270 GHz, Bw = 16.000 MH Calibrated with CL # 3 and BP # 1 (BP mode 1)

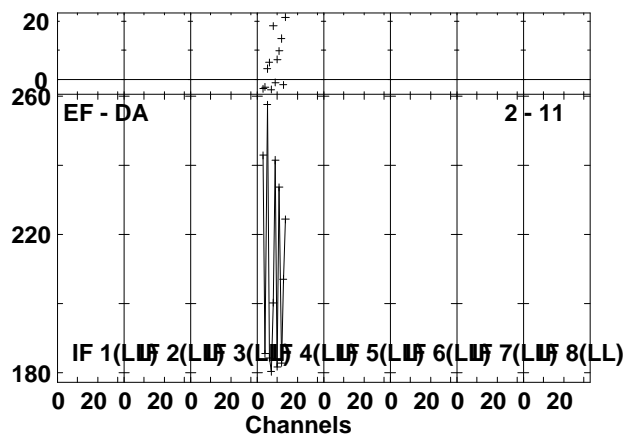
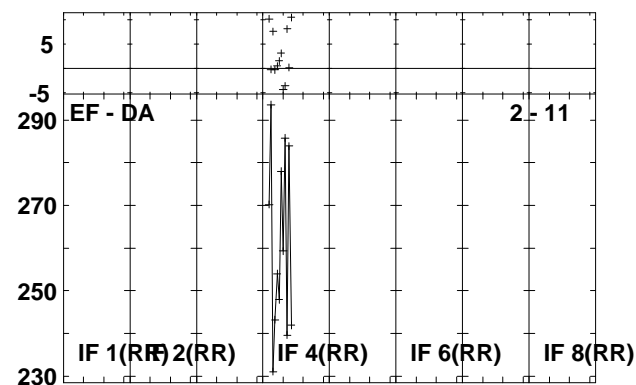
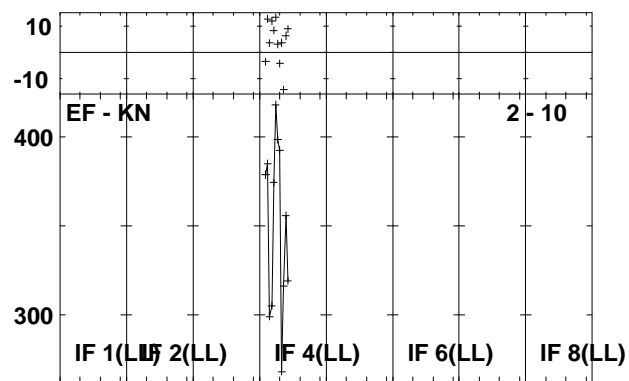
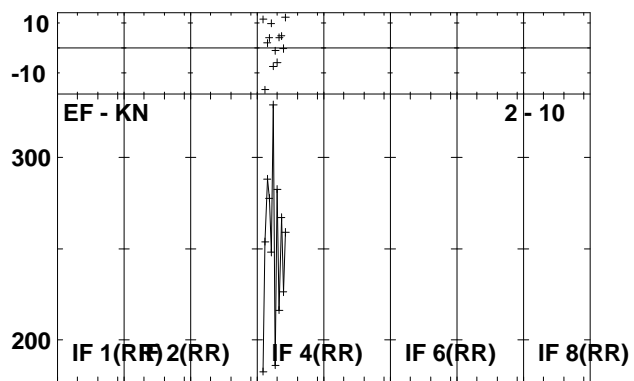
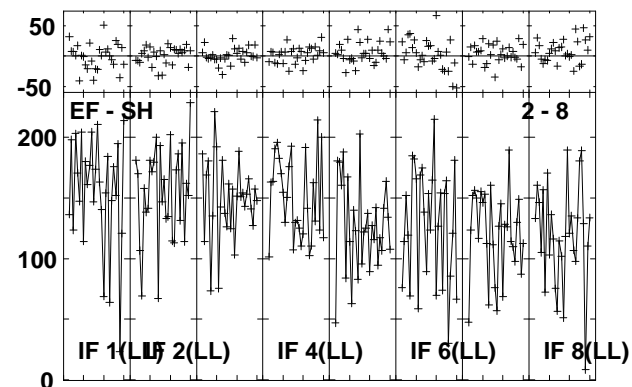
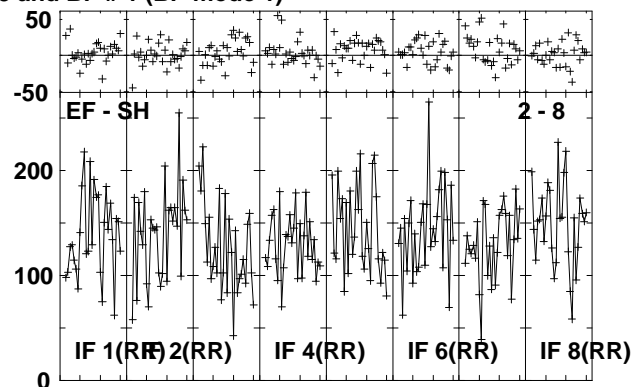
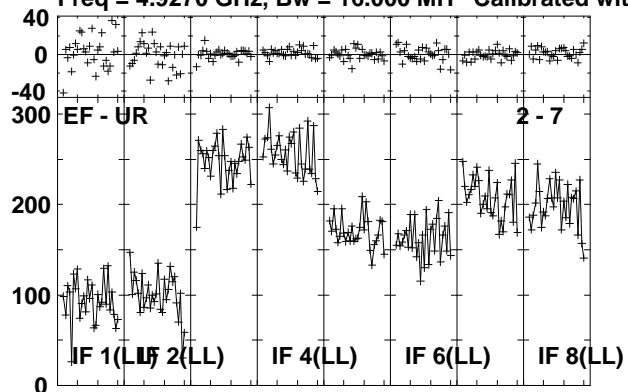

Lower frame: Milli Ampl Jy Top frame: Phas deg  
Vector averaged cross-power spectrum Several baselines displayed  
Timerange: 00/22:42:01 to 00/22:43:29

Plot file version 19 created 24-AUG-2010 08:15:23

IRAS1929 EP064M.UVDATA.1

Freq = 4.9270 GHz, Bw = 16.000 MH Calibrated with CL # 3 and BP # 1 (BP mode 1)

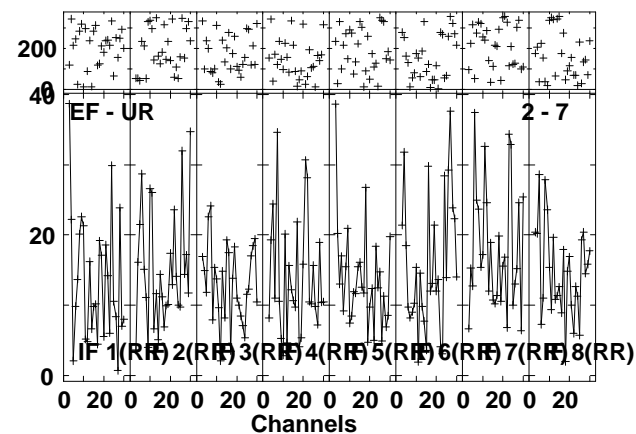
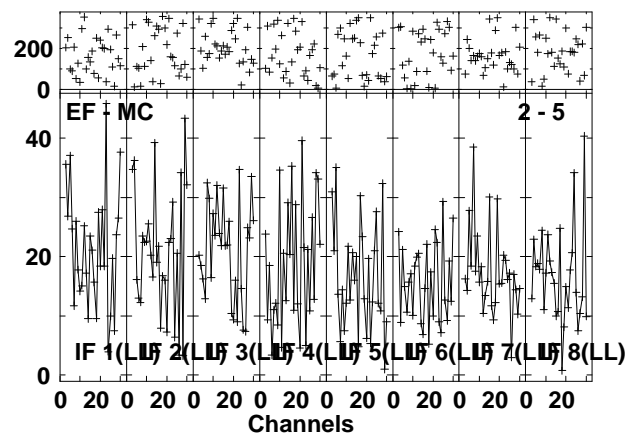
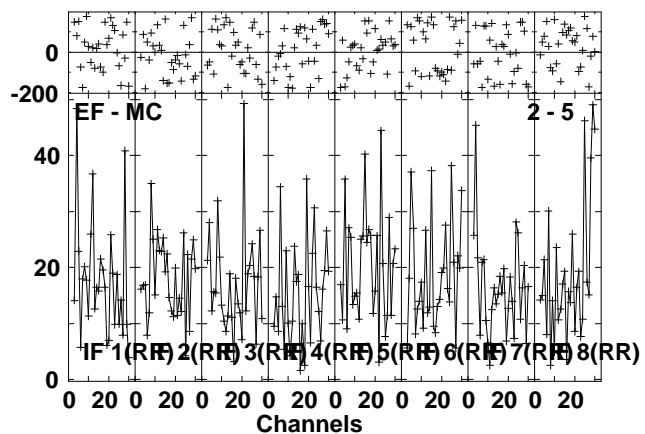
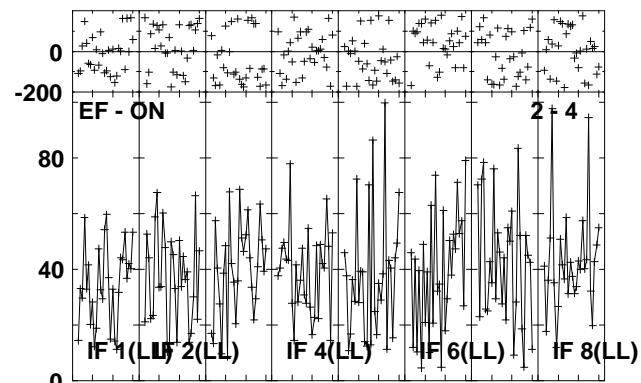
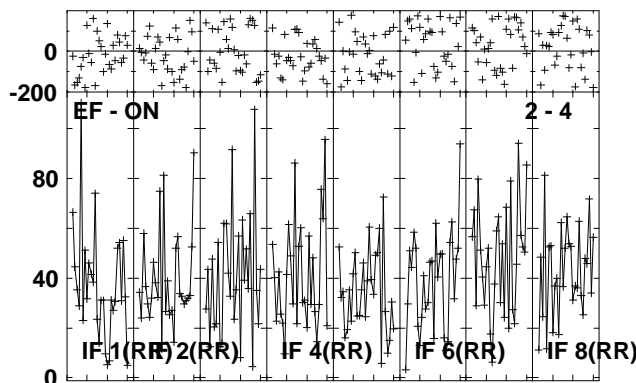
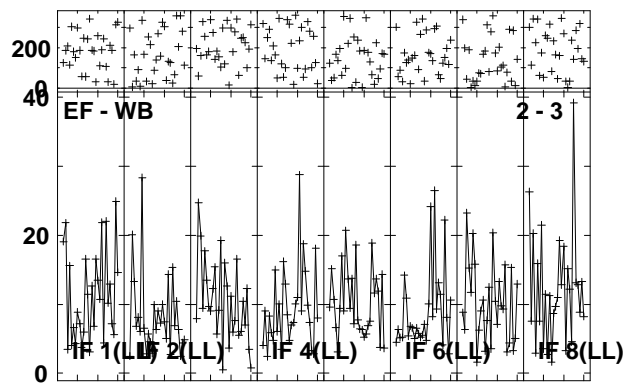
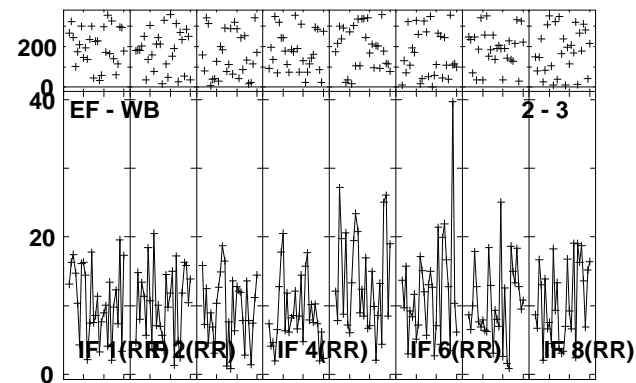
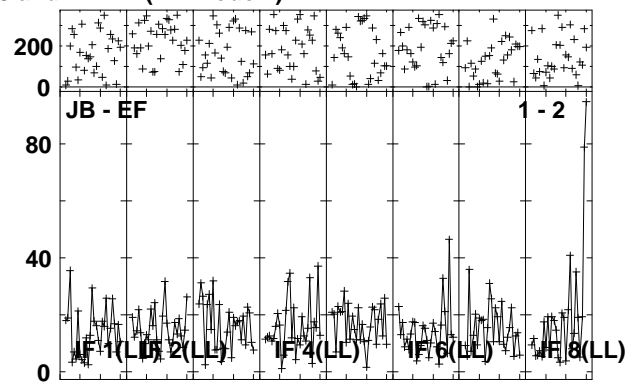
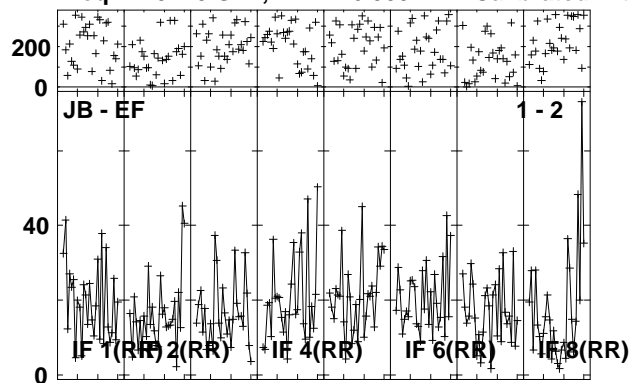

Lower frame: Milli Ampl Jy Top frame: Phas deg  
Vector averaged cross-power spectrum Several baselines displayed  
Timerange: 00/22:43:31 to 00/22:46:59

Plot file version 20 created 24-AUG-2010 08:15:27

IRAS1929 EP064M.UVDATA.1

Freq = 4.9270 GHz, Bw = 16.000 MH Calibrated with CL # 3 and BP # 1 (BP mode 1)

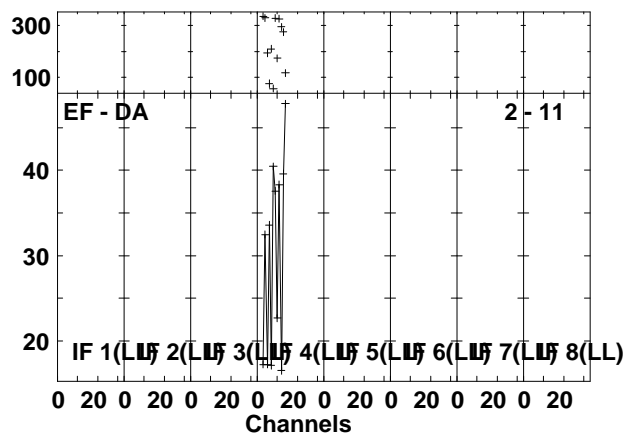
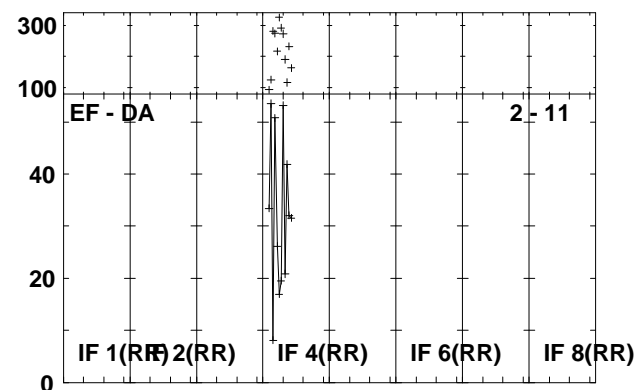
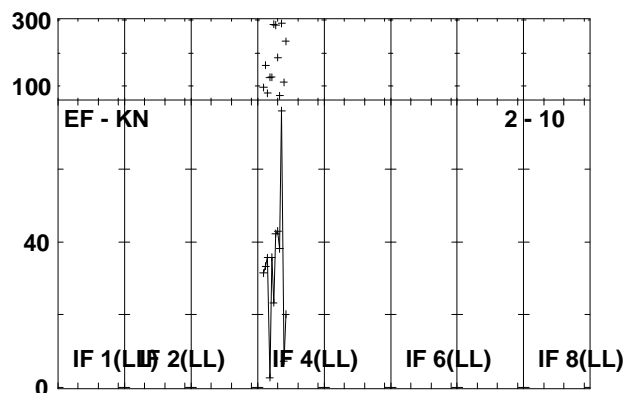
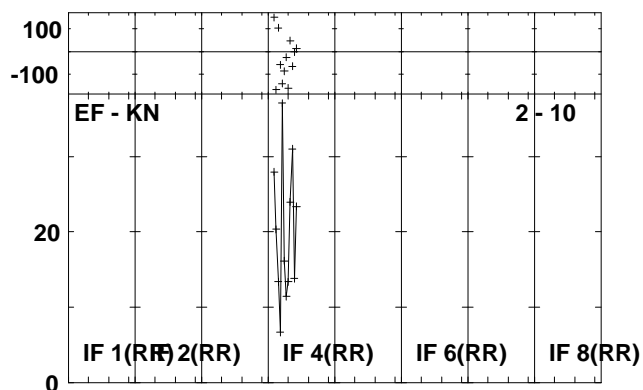
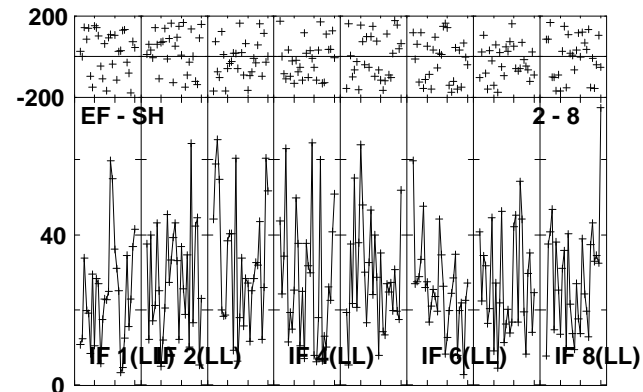
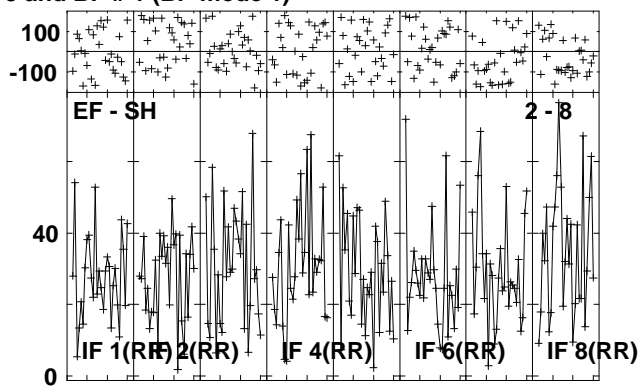
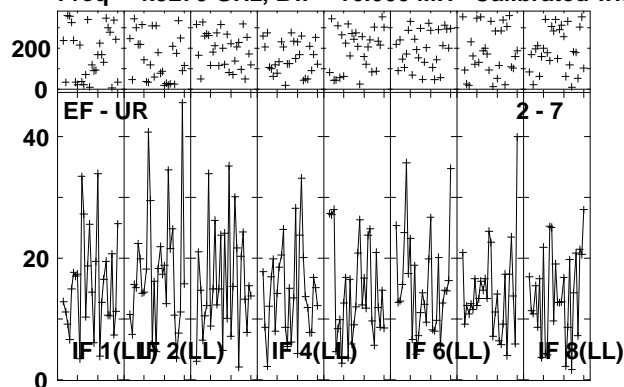

Lower frame: Milli Ampl Jy Top frame: Phas deg  
 Vector averaged cross-power spectrum Several baselines displayed  
 Timerange: 00/22:43:31 to 00/22:46:59

Plot file version 21 created 24-AUG-2010 08:15:30

J1941-05 EP064M.UVDATA.1

Freq = 4.9270 GHz, Bw = 16.000 MH Calibrated with CL # 3 and BP # 1 (BP mode 1)

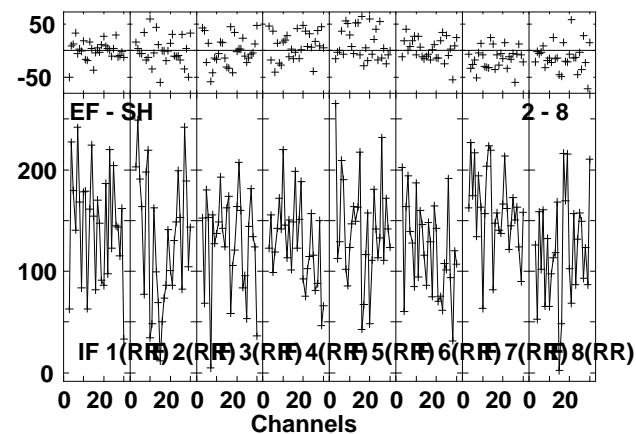
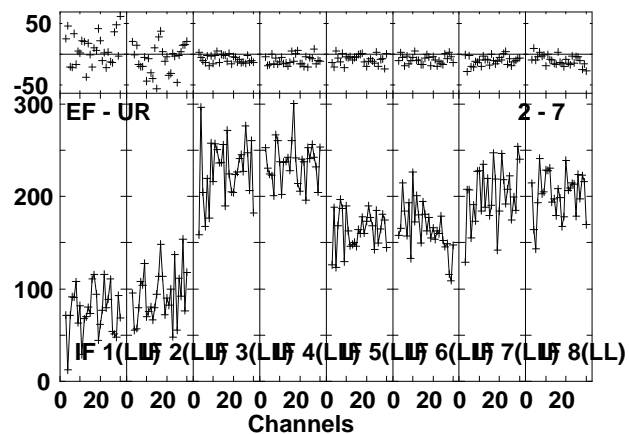
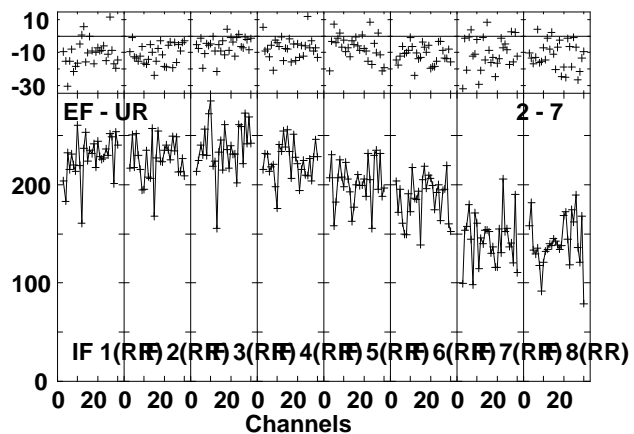
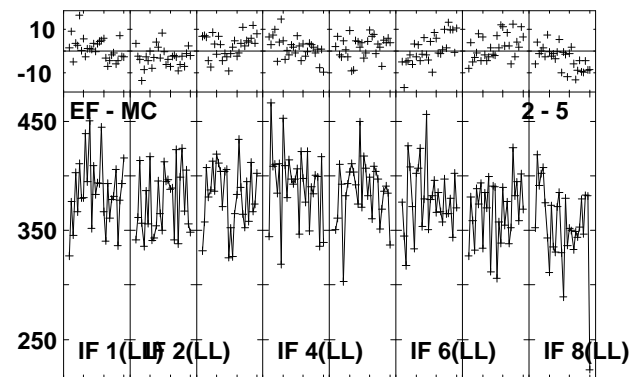
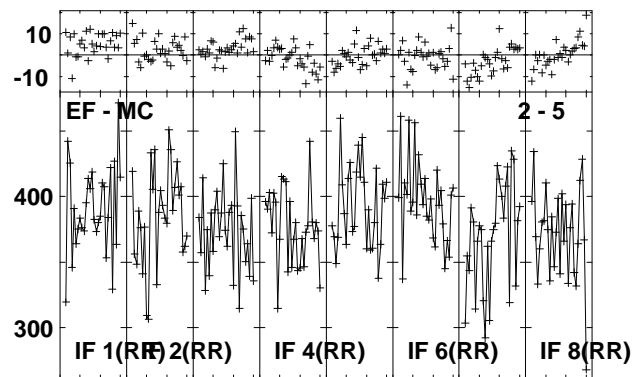
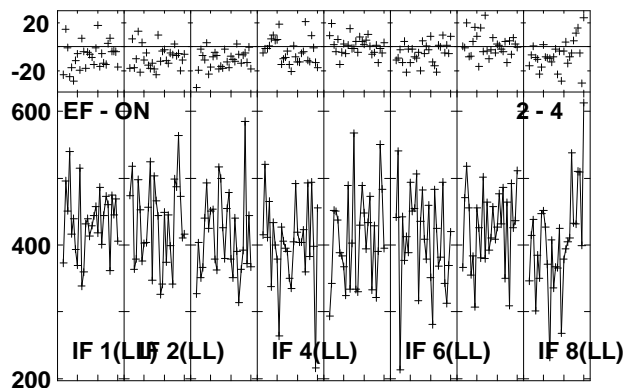
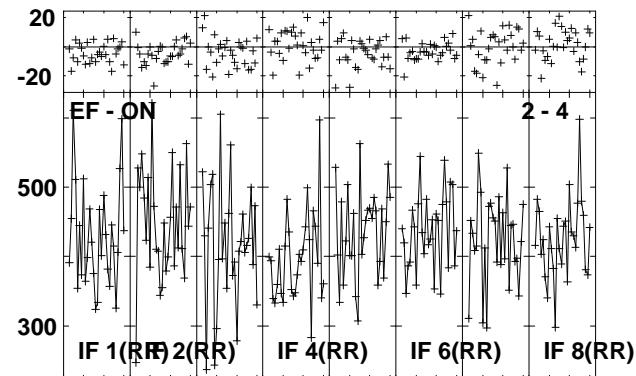
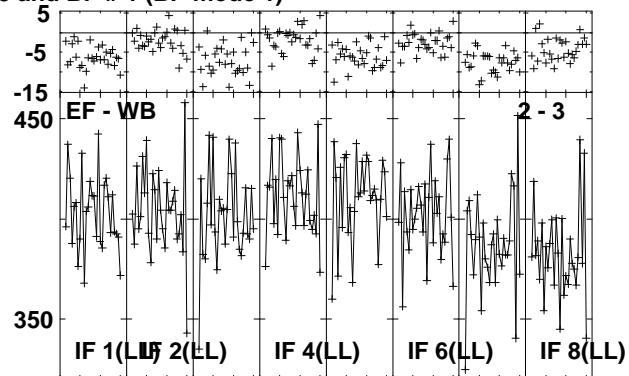
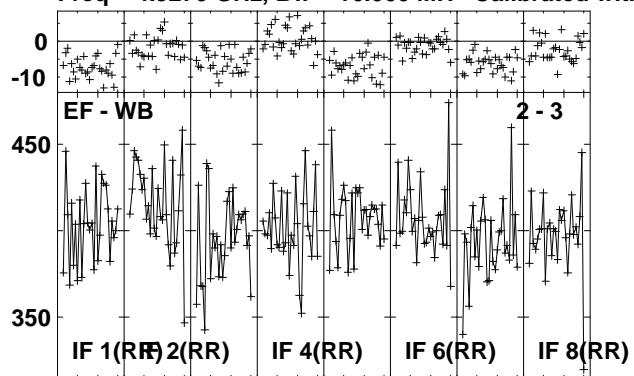

Lower frame: Milli Ampl Jy Top frame: Phas deg  
Vector averaged cross-power spectrum Several baselines displayed  
Timerange: 00/22:47:01 to 00/22:48:29

Plot file version 22 created 24-AUG-2010 08:15:32

J1941-05 EP064M.UVDATA.1

Freq = 4.9270 GHz, Bw = 16.000 MH Calibrated with CL # 3 and BP # 1 (BP mode 1)

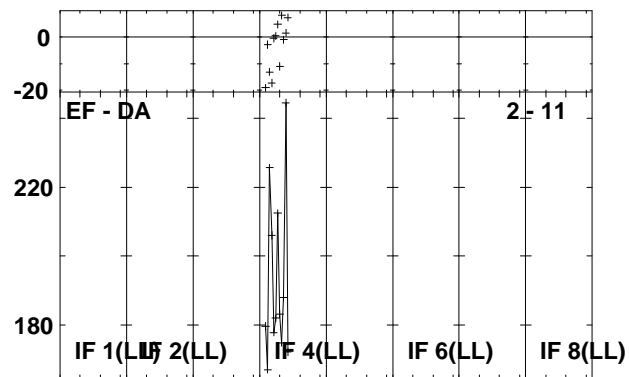
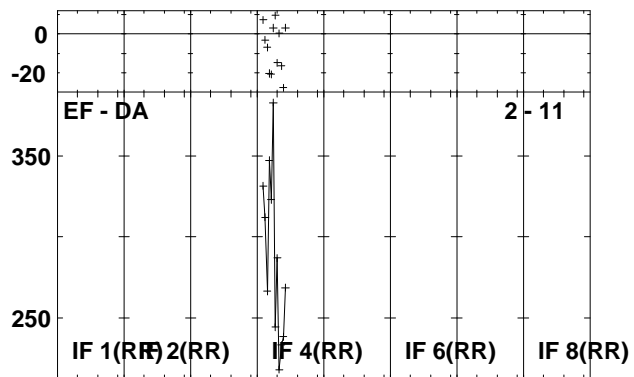
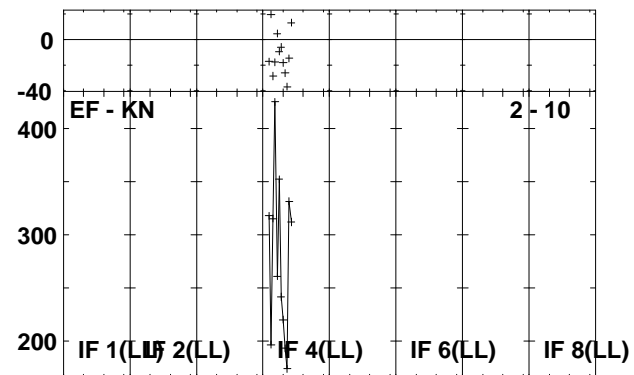
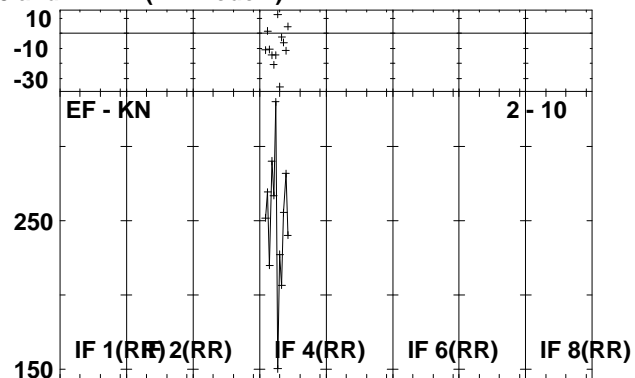
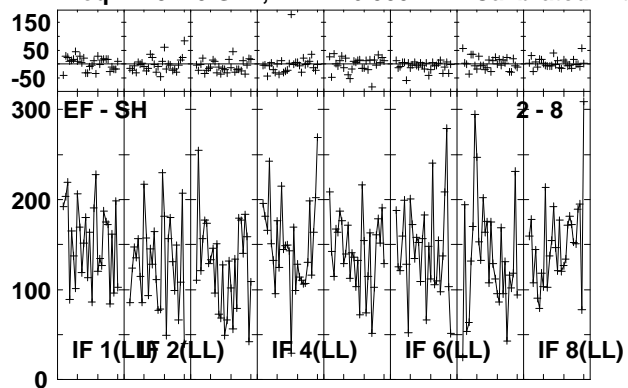

Lower frame: Milli Ampl Jy Top frame: Phas deg  
Vector averaged cross-power spectrum Several baselines displayed  
Timerange: 00/22:47:01 to 00/22:48:29

Plot file version 23 created 24-AUG-2010 08:15:33

IRAS1929 EP064M.UVDATA.1

Freq = 4.9270 GHz, Bw = 16.000 MH Calibrated with CL # 3 and BP # 1 (BP mode 1)

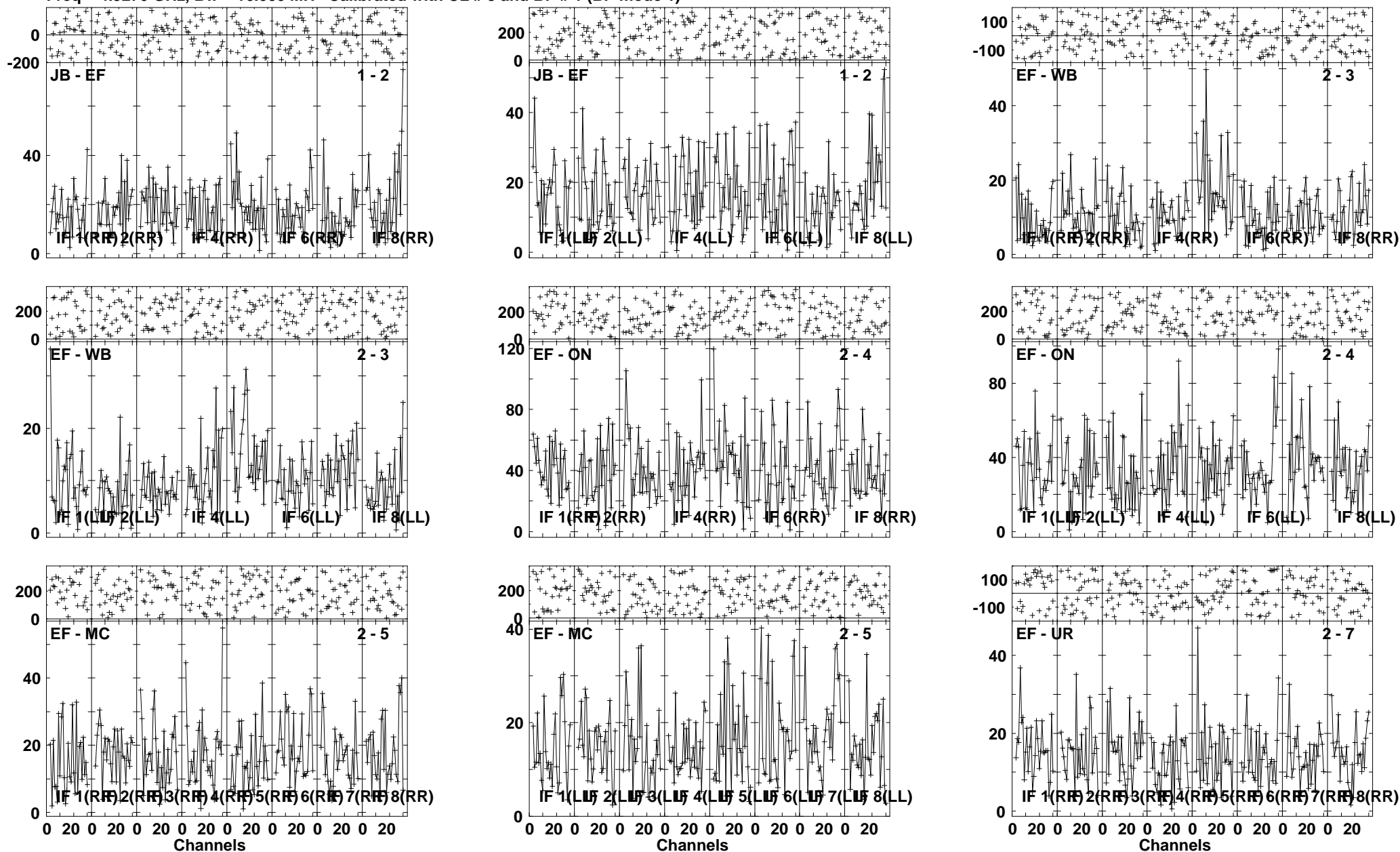

Lower frame: Milli Ampl Jy Top frame: Phas deg  
Vector averaged cross-power spectrum Several baselines displayed  
Timerange: 00/22:48:31 to 00/22:51:59

Plot file version 24 created 24-AUG-2010 08:15:37

IRAS1929 EP064M.UVDATA.1

Freq = 4.9270 GHz, Bw = 16.000 MH Calibrated with CL # 3 and BP # 1 (BP mode 1)

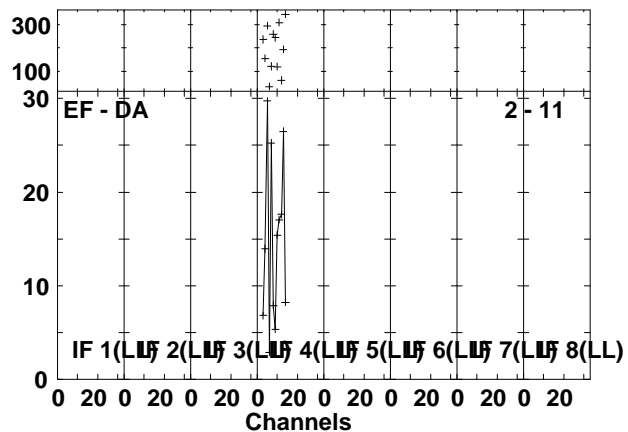
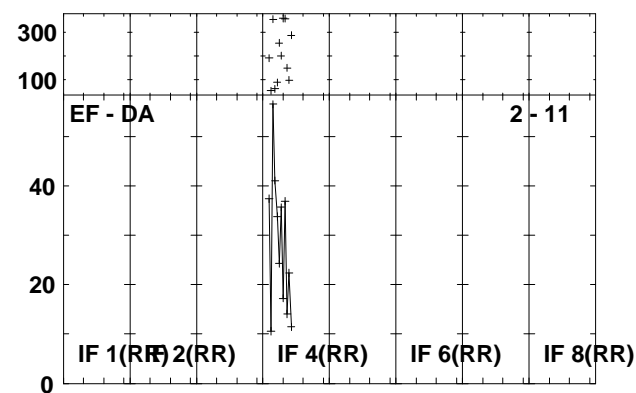
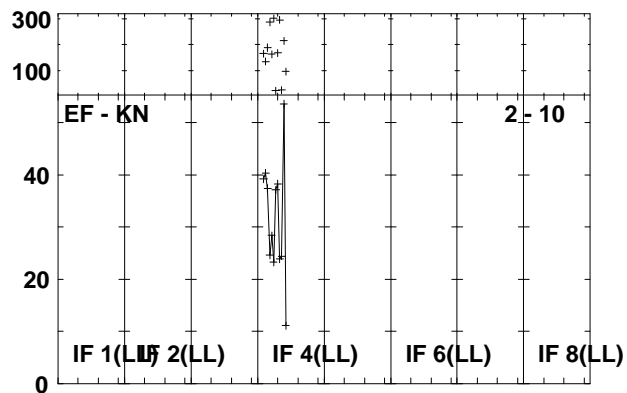
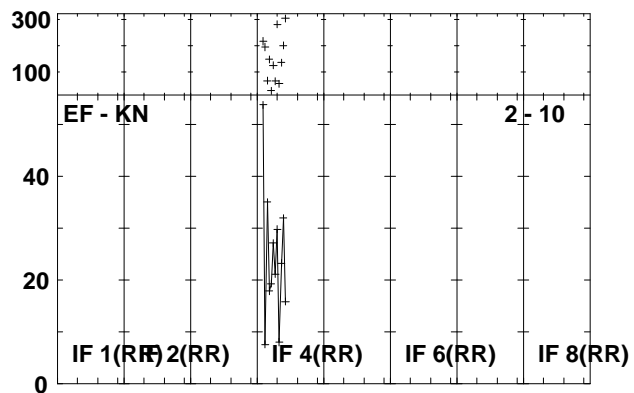
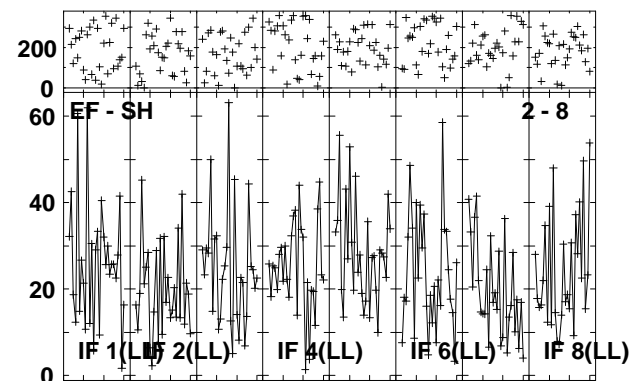
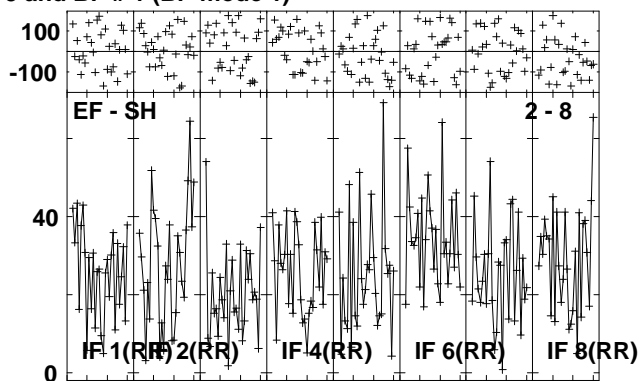
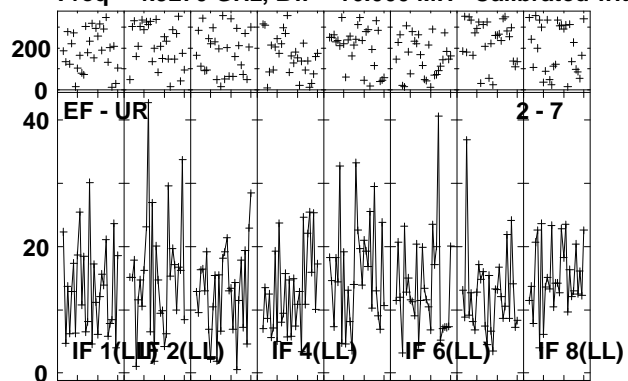

Lower frame: Milli Ampl Jy Top frame: Phas deg  
 Vector averaged cross-power spectrum Several baselines displayed  
 Timerange: 00/22:48:31 to 00/22:51:59



Plot file version 25 created 24-AUG-2010 08:15:40  
 J1941-05 EP064M.UVDATA.1  
 Freq = 4.9270 GHz, Bw = 16.000 MH Calibrated with CL # 3 and BP # 1 (BP mode 1)

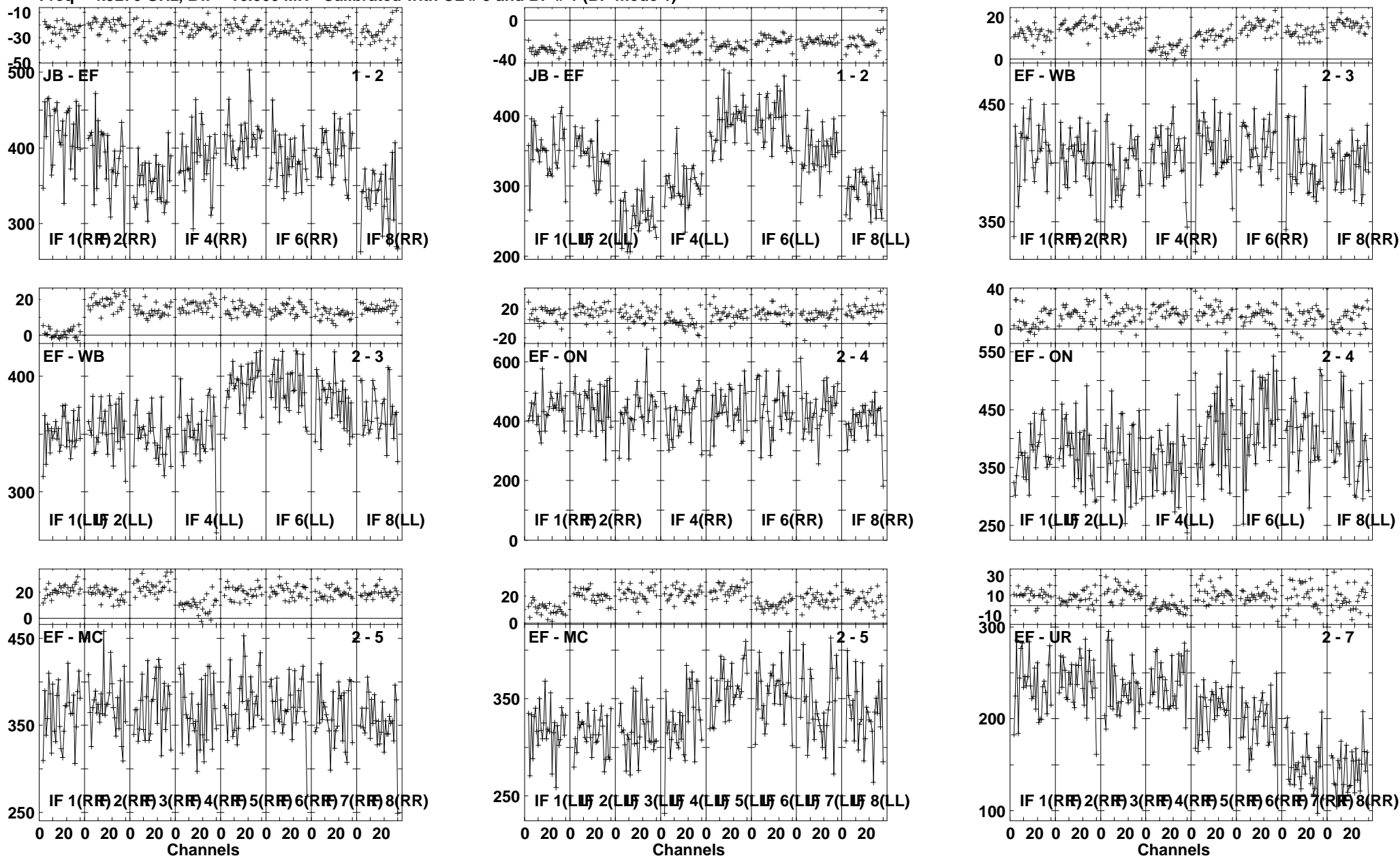

Lower frame: Milli Ampl Jy Top frame: Phas deg  
 Vector averaged cross-power spectrum Several baselines displayed  
 Timerange: 00/22:52:01 to 00/22:53:29



Plot file version 27 created 24-AUG-2010 08:15:44

IRAS1929 EP064M.UVDATA.1

Freq = 4.9270 GHz, Bw = 16.000 MH Calibrated with CL # 3 and BP # 1 (BP mode 1)

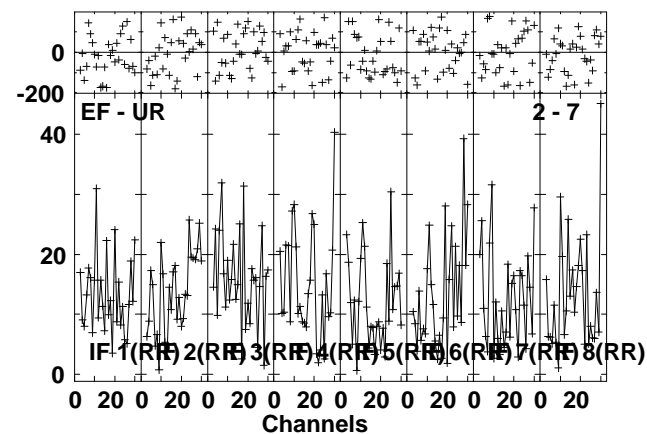
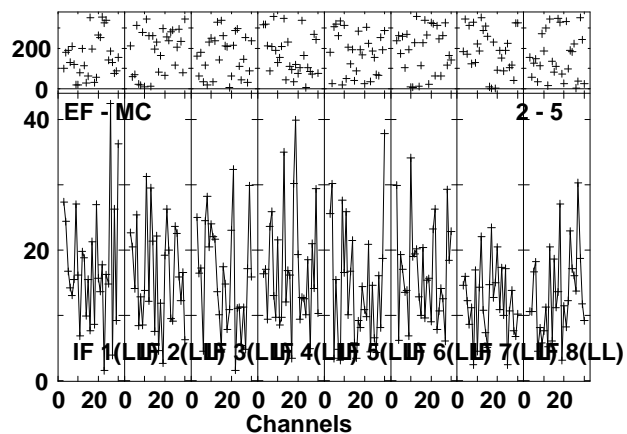
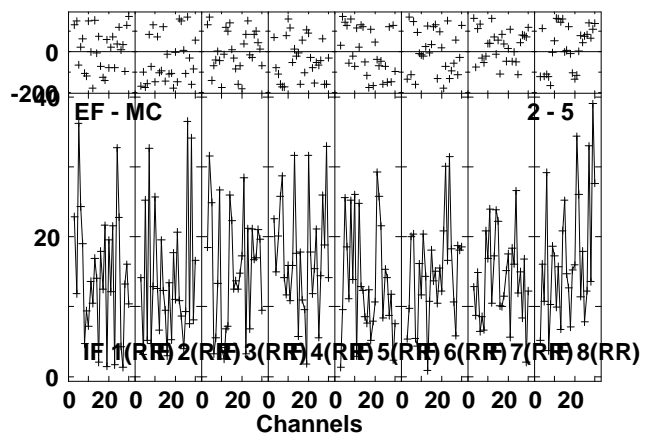
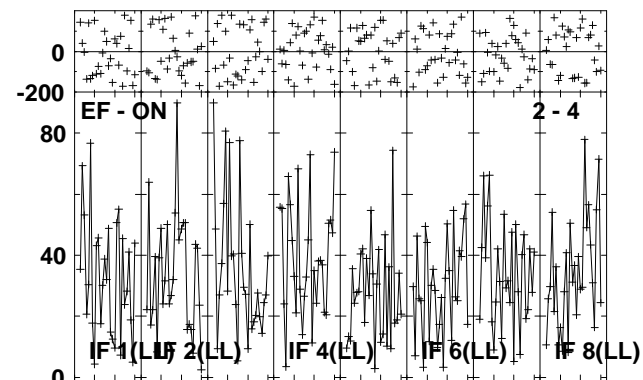
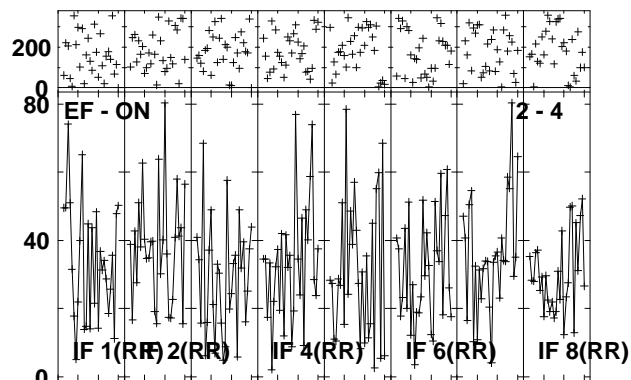
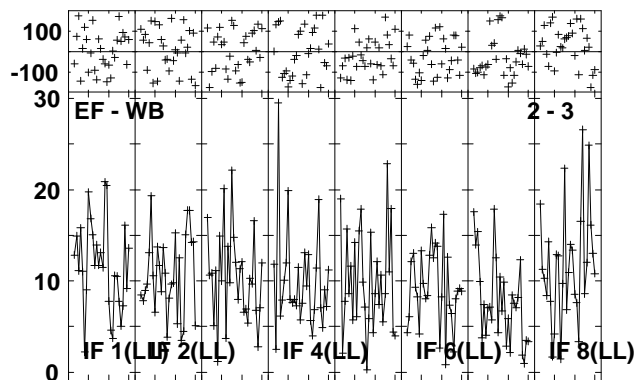
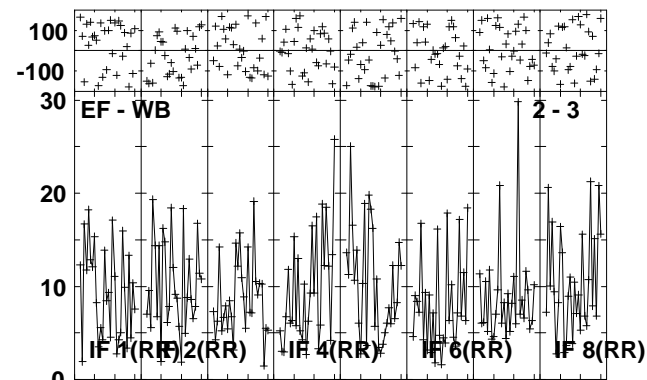
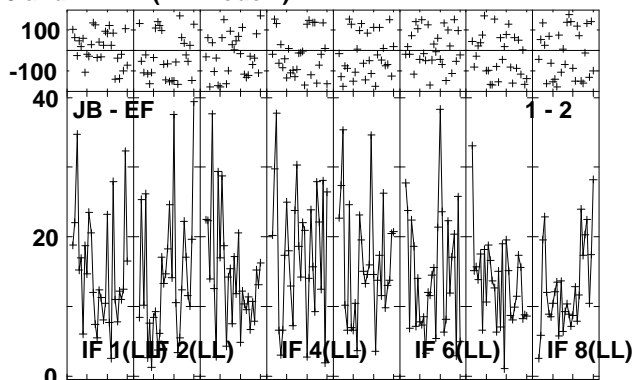
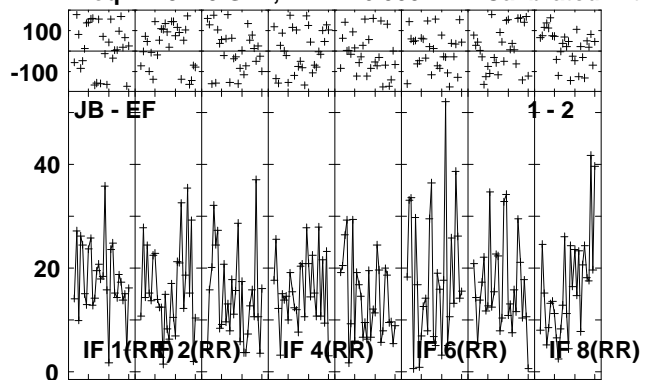

Lower frame: Milli Ampl Jy Top frame: Phas deg  
Vector averaged cross-power spectrum Several baselines displayed  
Timerange: 00/22:53:31 to 00/22:56:59

Plot file version 28 created 24-AUG-2010 08:15:49

IRAS1929 EP064M.UVDATA.1

Freq = 4.9270 GHz, Bw = 16.000 MH Calibrated with CL # 3 and BP # 1 (BP mode 1)

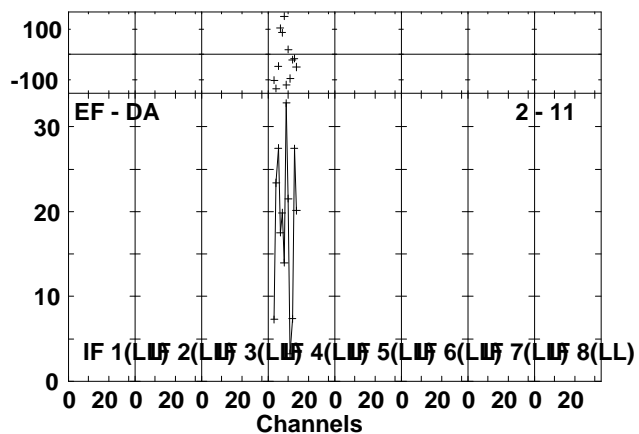
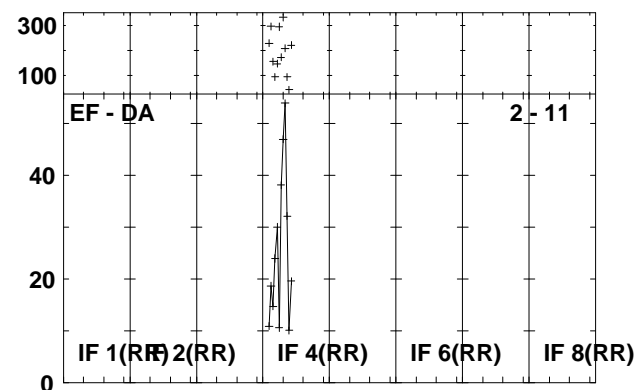
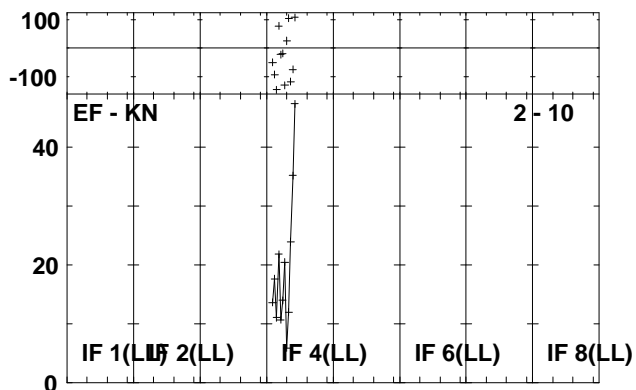
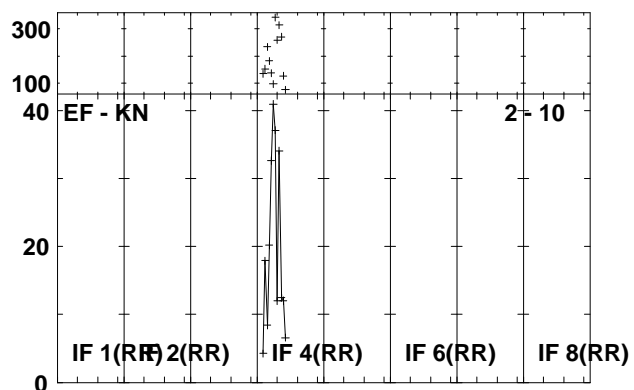
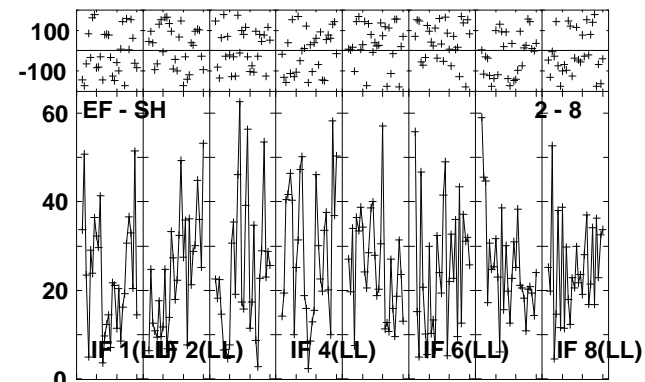
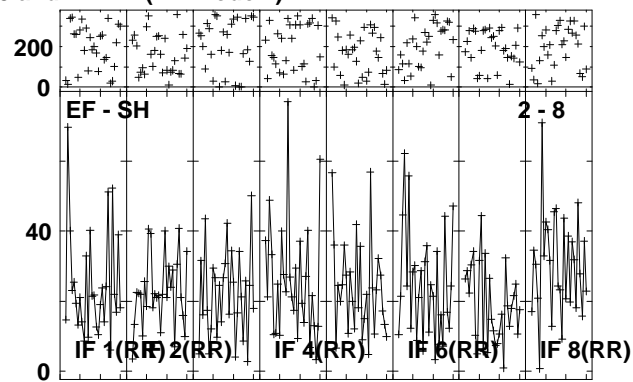
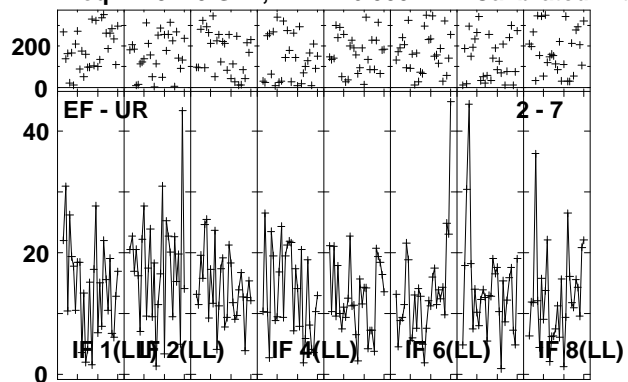

Lower frame: Milli Ampl Jy Top frame: Phas deg  
Vector averaged cross-power spectrum Several baselines displayed  
Timerange: 00/22:53:31 to 00/22:56:59

Plot file version 29 created 24-AUG-2010 08:15:55

IRAS1929 EP064M.UVDATA.1

Freq = 4.9270 GHz, Bw = 16.000 MH Calibrated with CL # 3 and BP # 1 (BP mode 1)

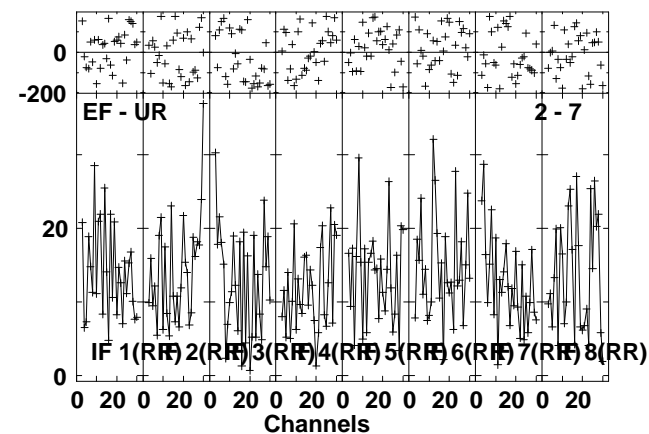
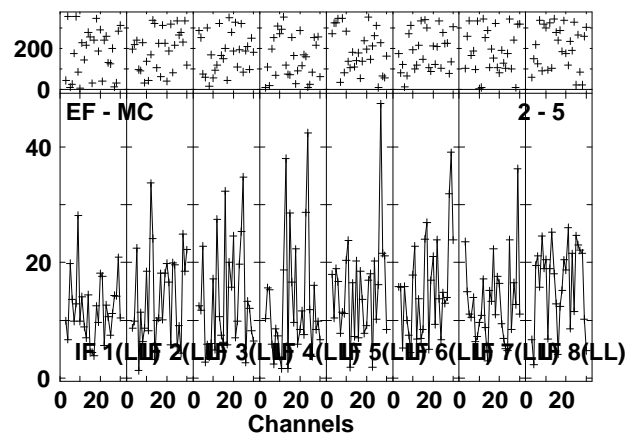
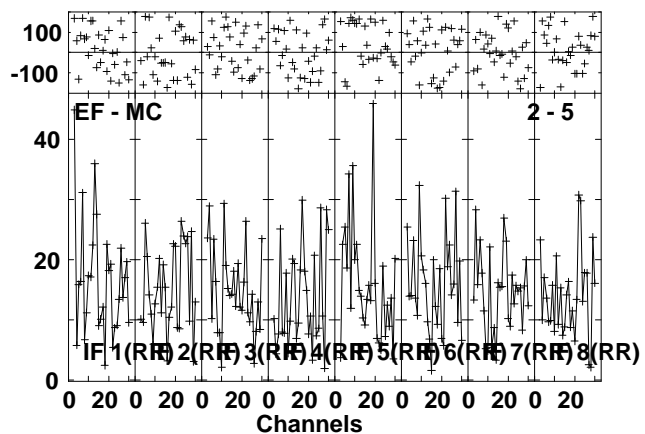
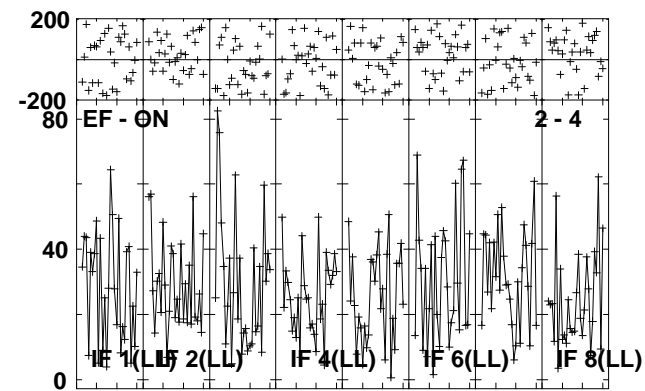
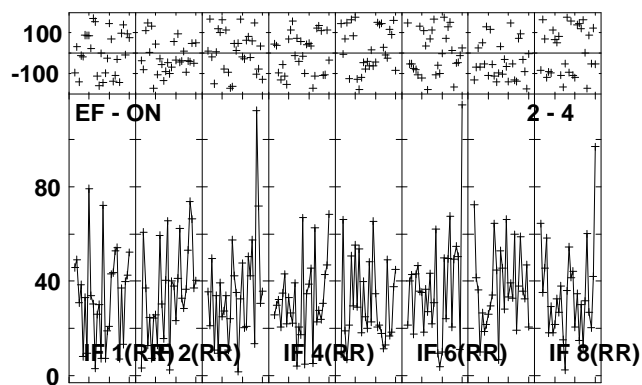
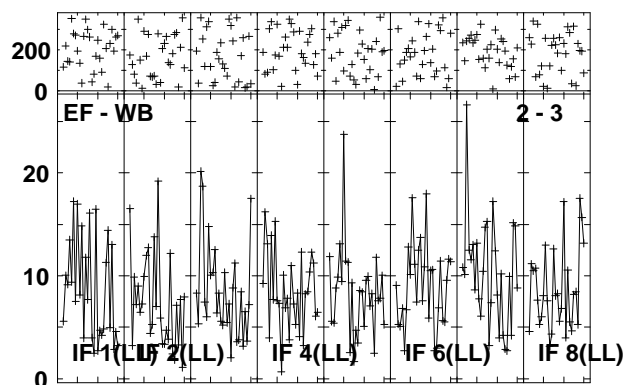
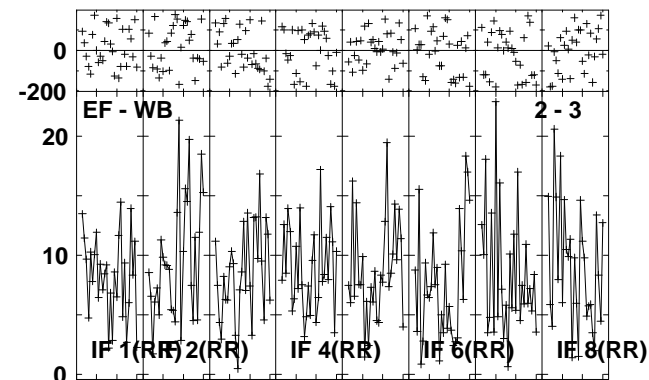
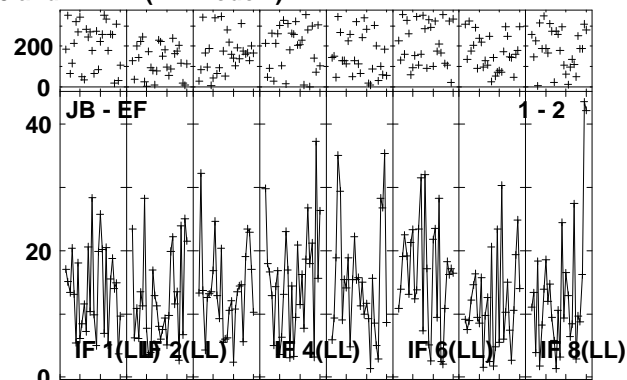
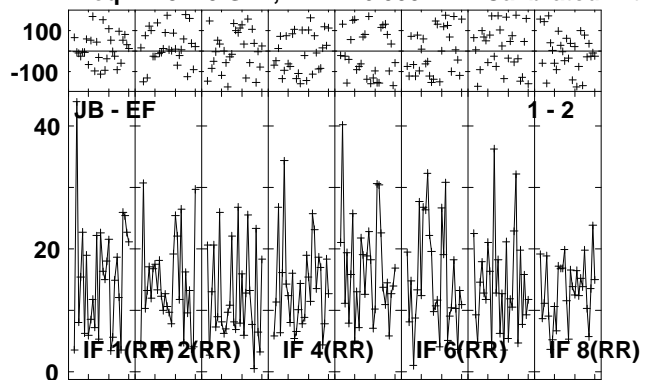

Lower frame: Milli Ampl Jy Top frame: Phas deg  
Vector averaged cross-power spectrum Several baselines displayed  
Timerange: 00/22:59:31 to 00/23:02:59



Plot file version 31 created 24-AUG-2010 08:16:03

J1941-05 EP064M.UVDATA.1

Freq = 4.9270 GHz, Bw = 16.000 MH Calibrated with CL # 3 and BP # 1 (BP mode 1)

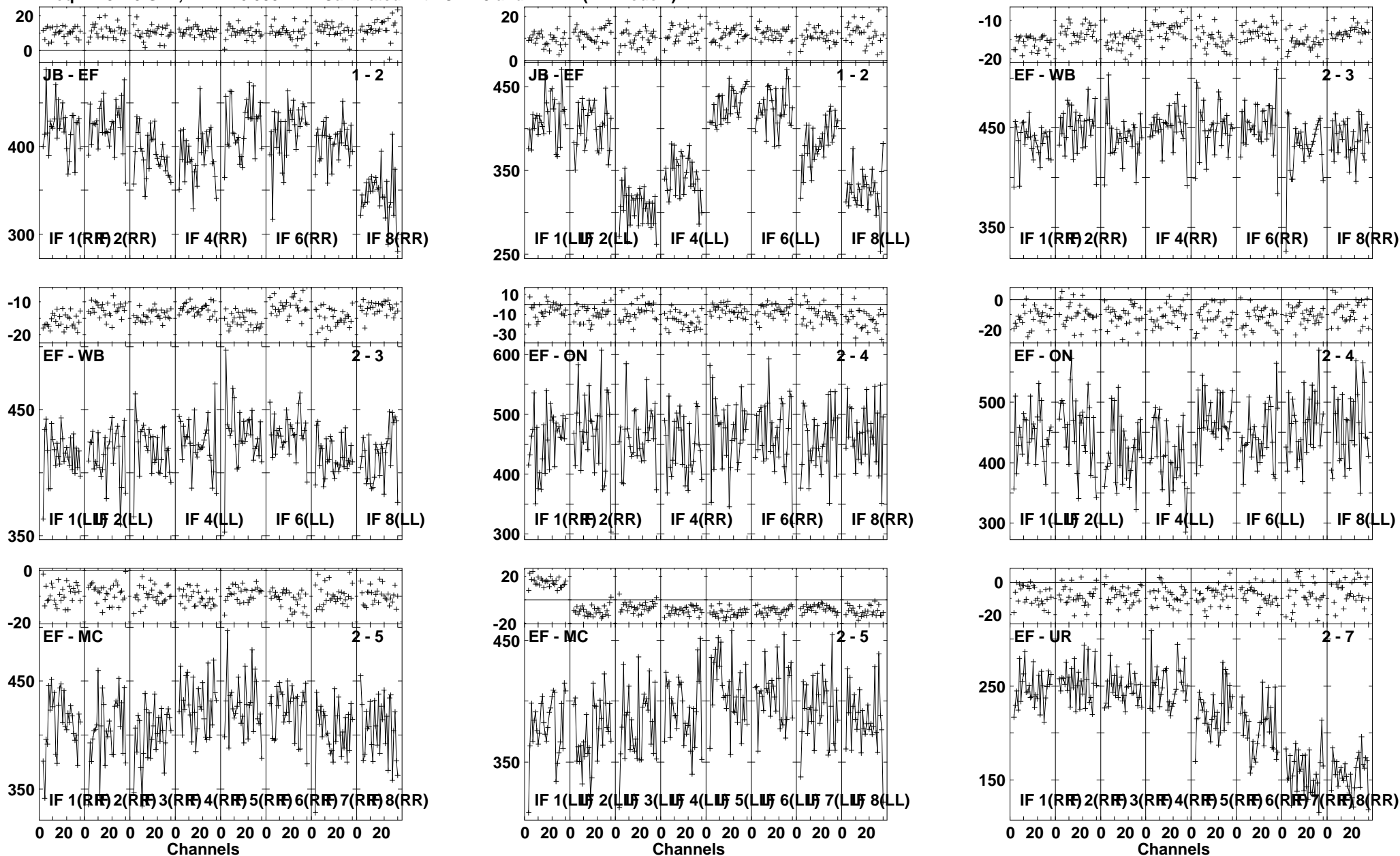

Lower frame: Milli Ampl Jy Top frame: Phas deg  
Vector averaged cross-power spectrum Several baselines displayed  
Timerange: 00/23:03:01 to 00/23:04:29





Plot file version 33 created 24-AUG-2010 08:16:07

IRAS1929 EP064M.UVDATA.1

Freq = 4.9270 GHz, Bw = 16.000 MH Calibrated with CL # 3 and BP # 1 (BP mode 1)

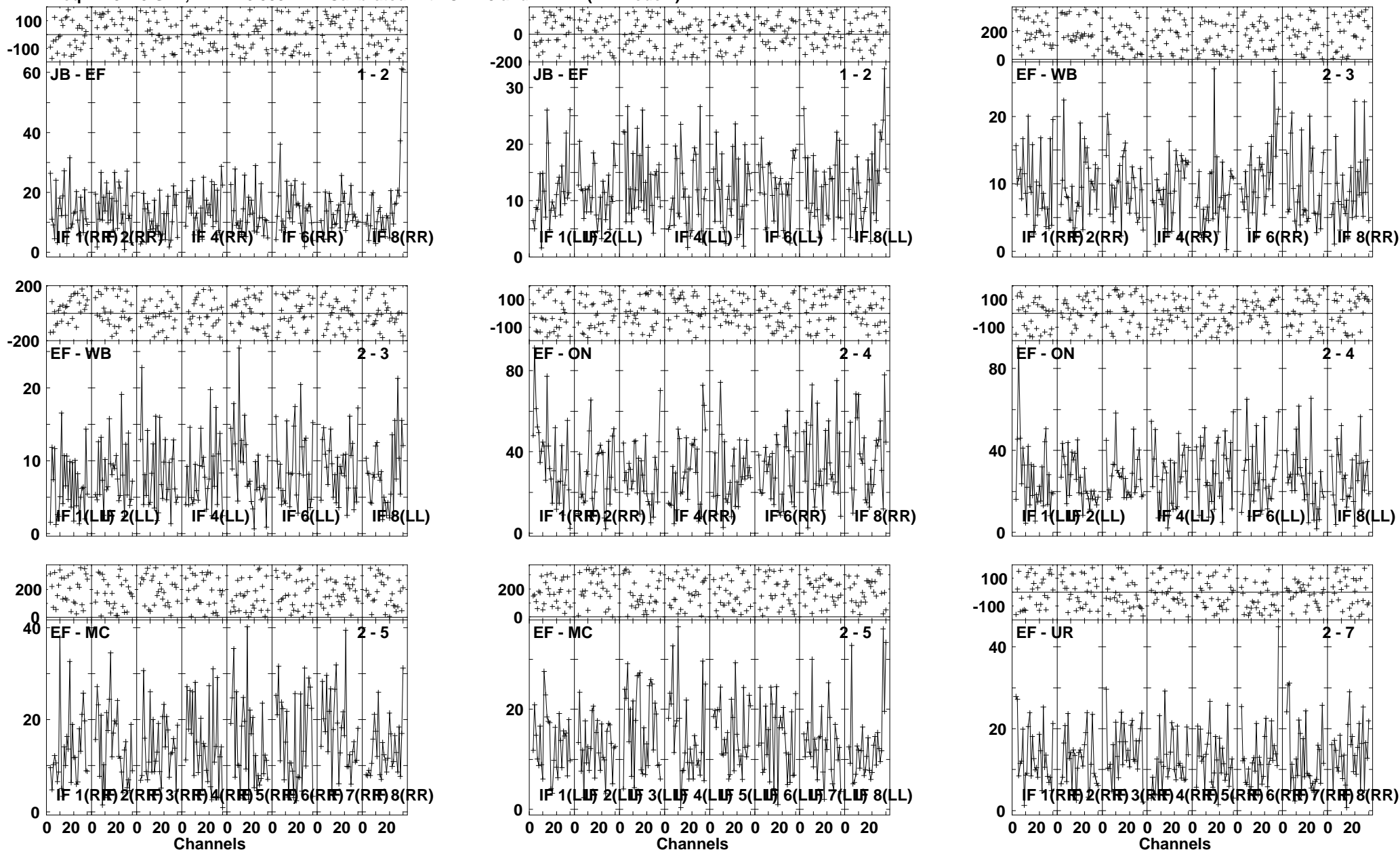

Lower frame: Milli Ampl Jy Top frame: Phas deg  
Vector averaged cross-power spectrum Several baselines displayed  
Timerange: 00/23:04:31 to 00/23:07:59

Plot file version 34 created 24-AUG-2010 08:16:12  
 IRAS1929 EP064M.UVDATA.1  
 Freq = 4.9270 GHz, Bw = 16.000 MH Calibrated with CL # 3 and BP # 1 (BP mode 1)

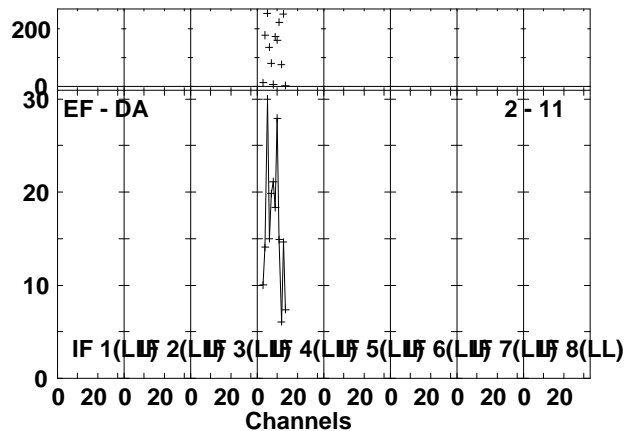
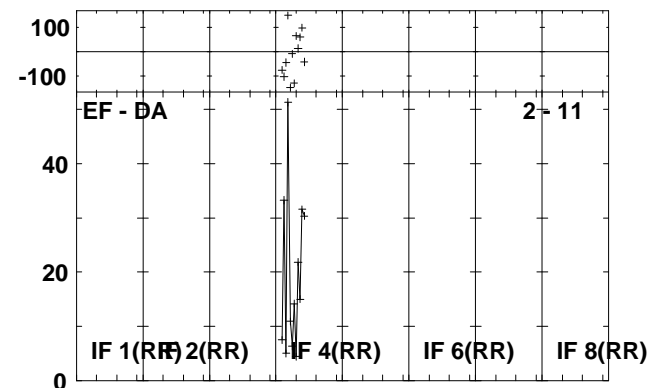
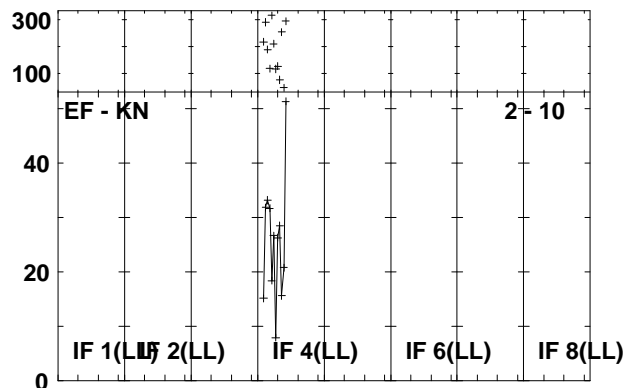
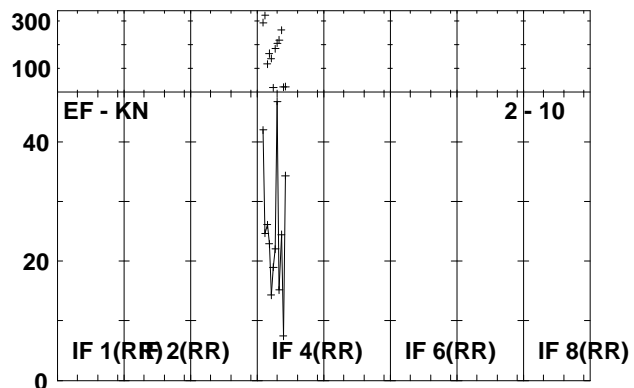
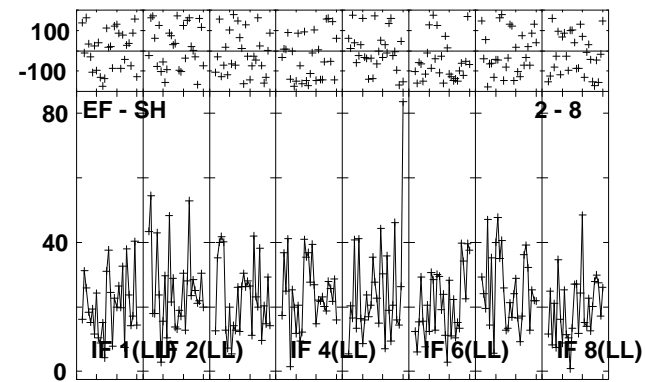
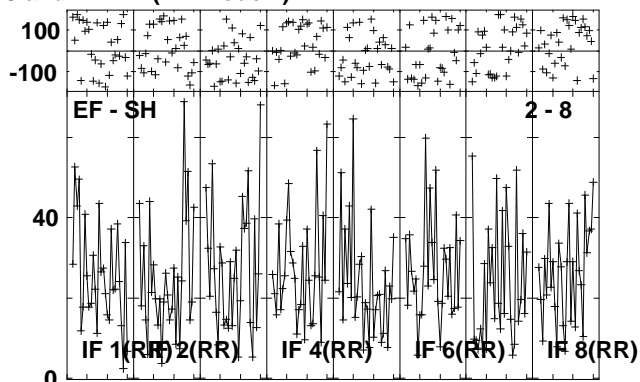
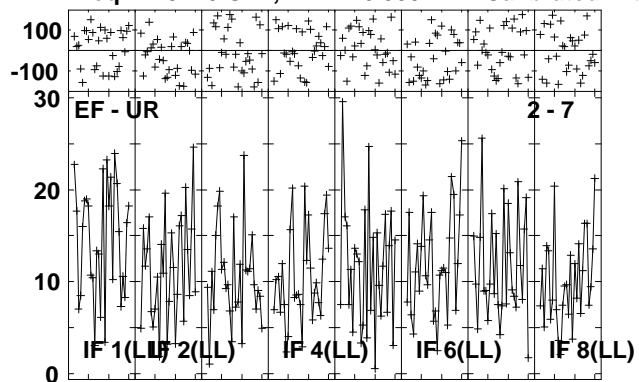

Lower frame: Milli Ampl Jy Top frame: Phas deg  
 Vector averaged cross-power spectrum Several baselines displayed  
 Timerange: 00/23:04:31 to 00/23:07:59

Plot file version 35 created 24-AUG-2010 08:16:16  
 J1941-05 EP064M.UVDATA.1  
 Freq = 4.9270 GHz, Bw = 16.000 MH Calibrated with CL # 3 and BP # 1 (BP mode 1)

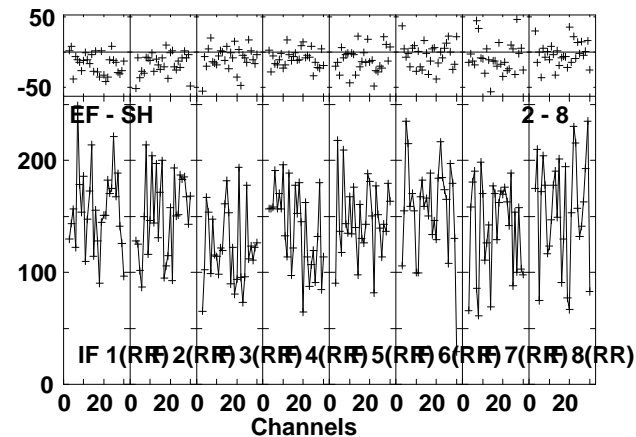
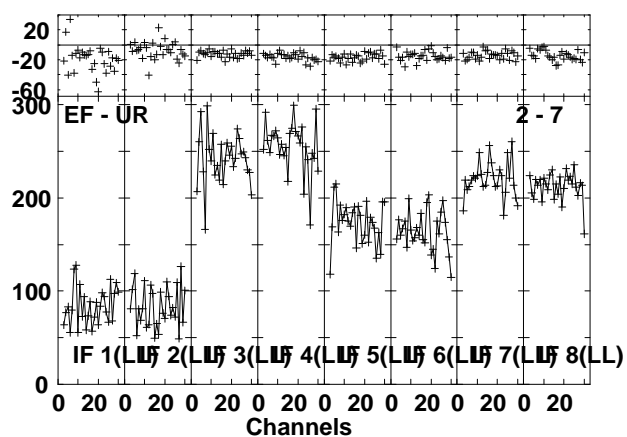
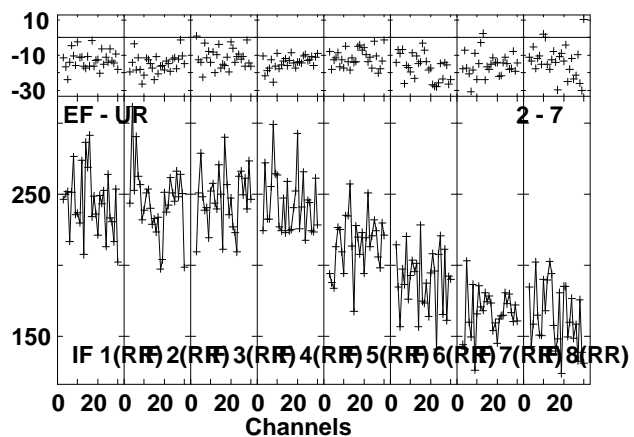
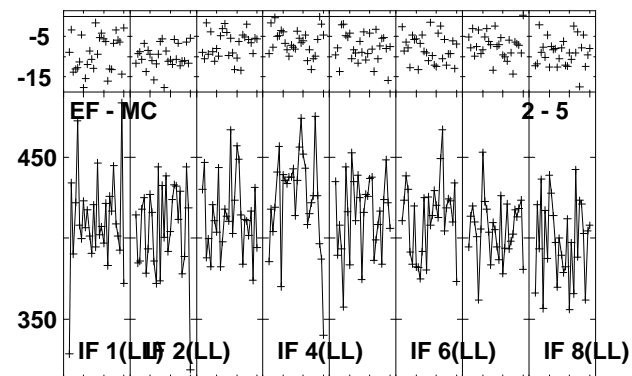
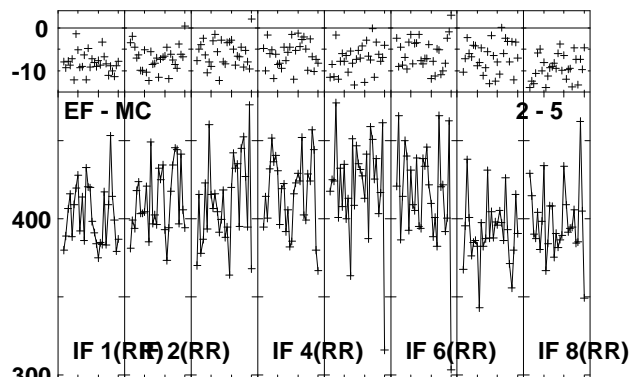
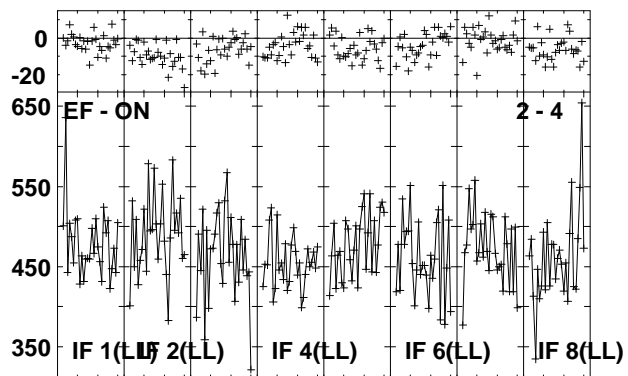
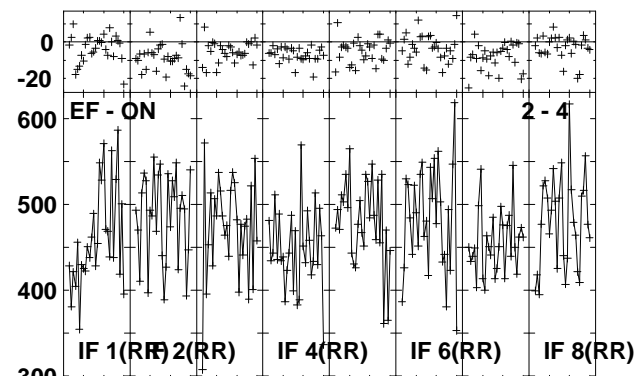
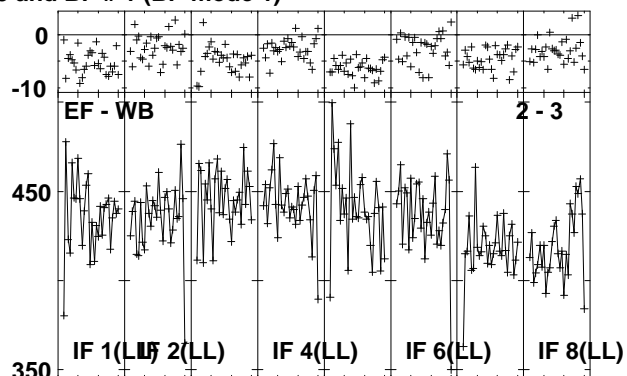
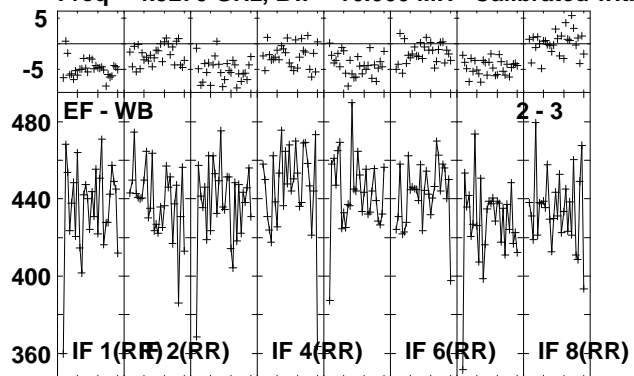

Lower frame: Milli Ampl Jy Top frame: Phas deg  
 Vector averaged cross-power spectrum Several baselines displayed  
 Timerange: 00/23:08:01 to 00/23:09:29

Plot file version 36 created 24-AUG-2010 08:16:17

J1941-05 EP064M.UVDATA.1

Freq = 4.9270 GHz, Bw = 16.000 MH Calibrated with CL # 3 and BP # 1 (BP mode 1)

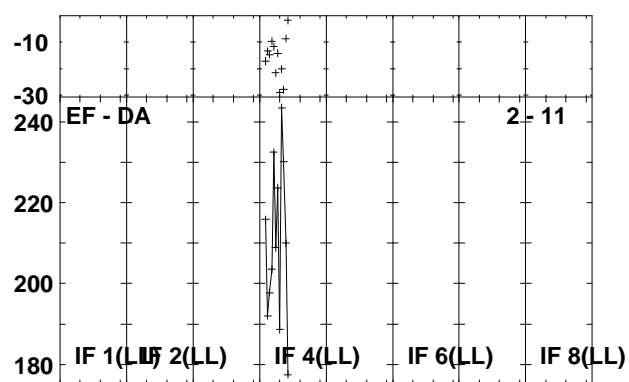
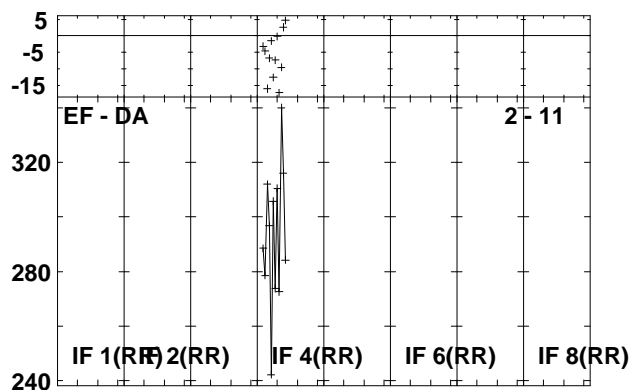
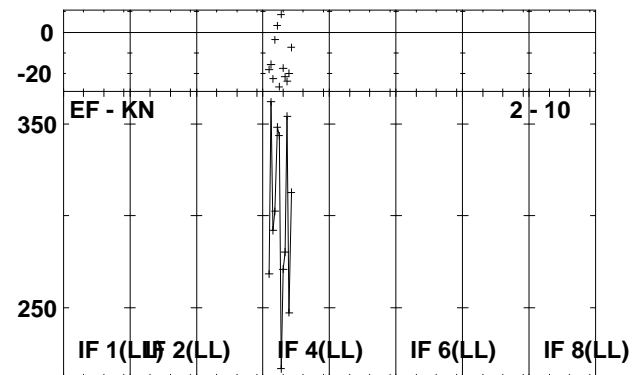
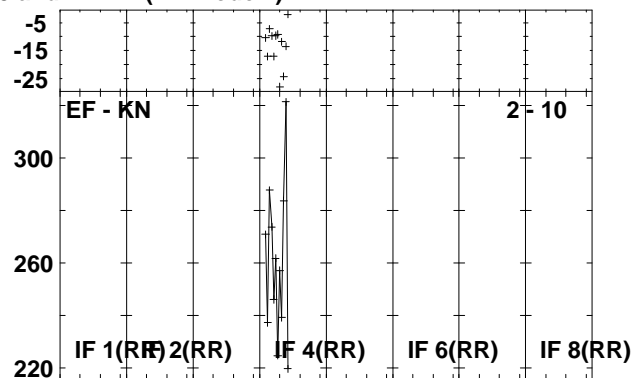
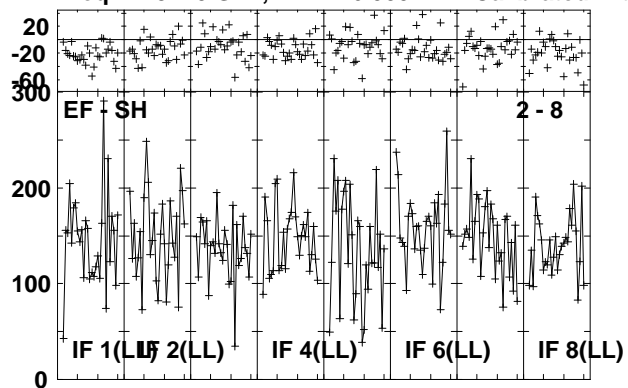

Lower frame: Milli Ampl Jy Top frame: Phas deg  
Vector averaged cross-power spectrum Several baselines displayed  
Timerange: 00/23:08:01 to 00/23:09:29

Plot file version 37 created 24-AUG-2010 08:16:18

IRAS1929 EP064M.UVDATA.1

Freq = 4.9270 GHz, Bw = 16.000 MH Calibrated with CL # 3 and BP # 1 (BP mode 1)

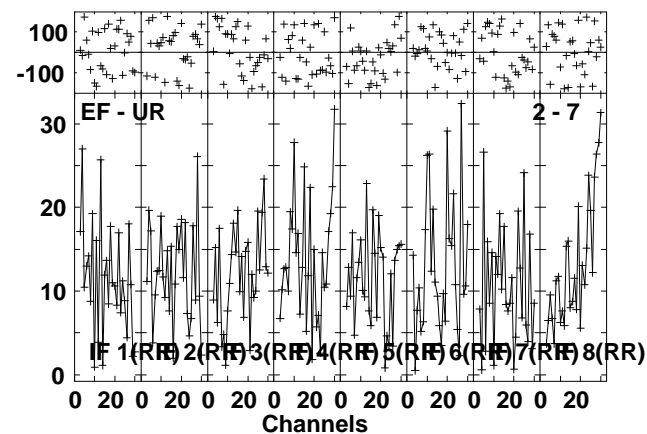
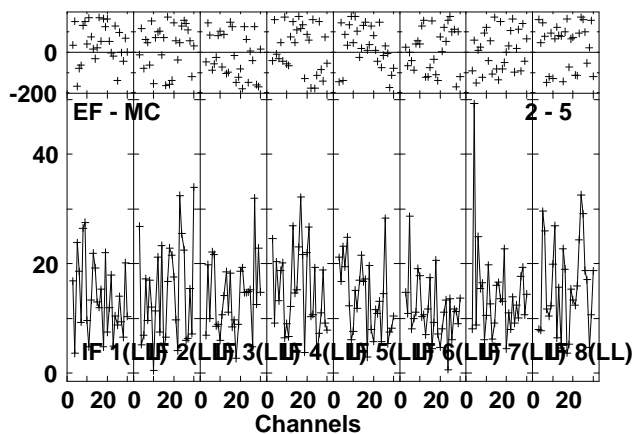
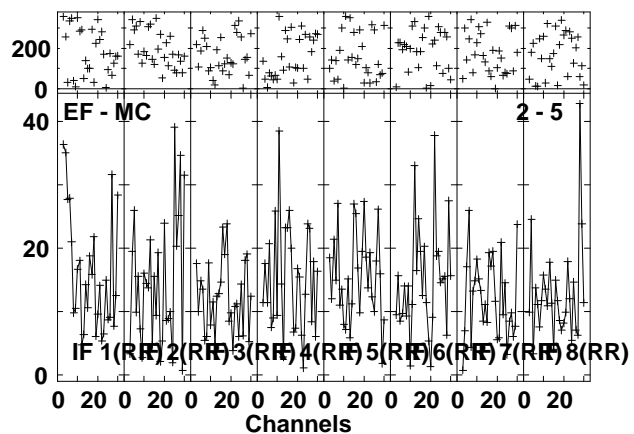
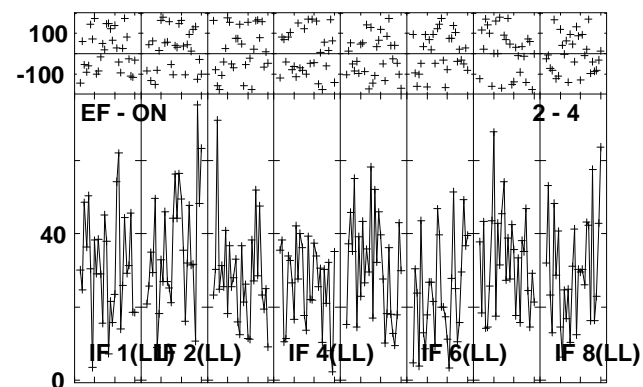
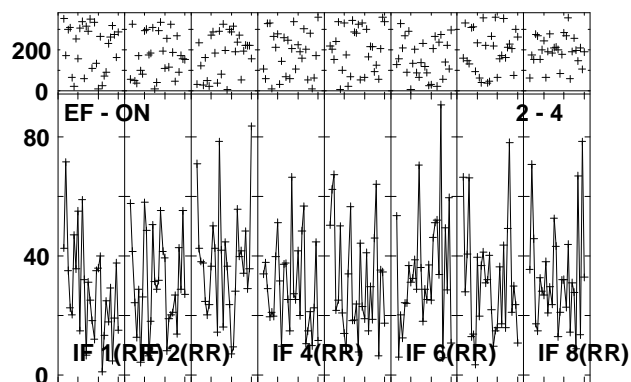
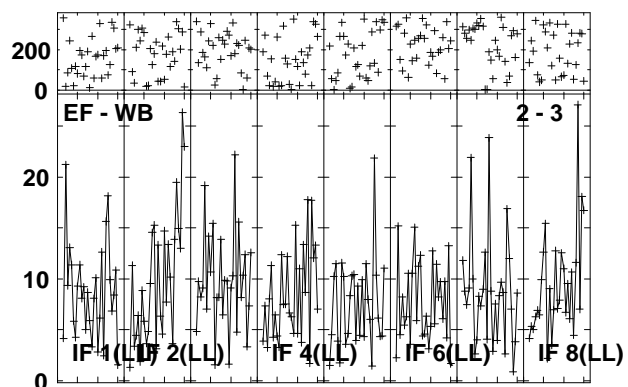
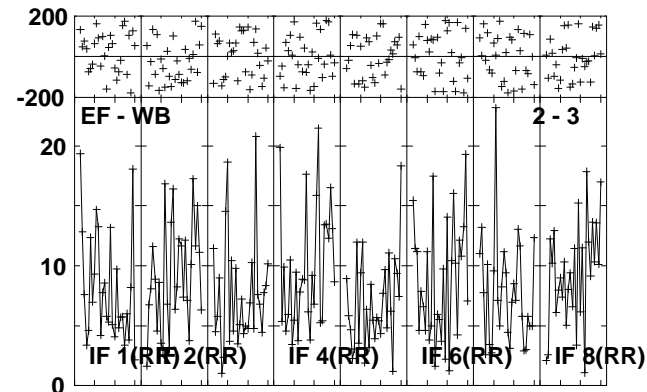
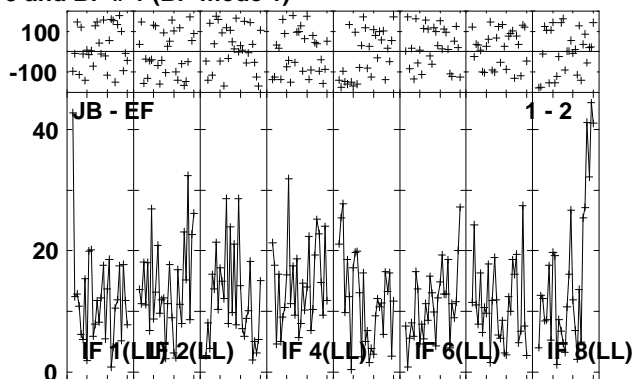
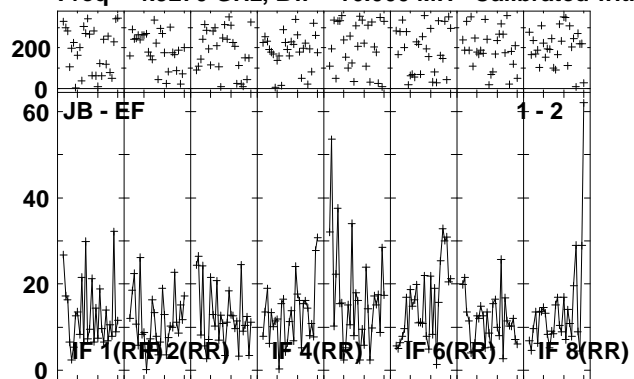

Lower frame: Milli Ampl Jy Top frame: Phas deg  
Vector averaged cross-power spectrum Several baselines displayed  
Timerange: 00/23:09:31 to 00/23:12:59

Plot file version 38 created 24-AUG-2010 08:16:22

IRAS1929 EP064M.UVDATA.1

Freq = 4.9270 GHz, Bw = 16.000 MH Calibrated with CL # 3 and BP # 1 (BP mode 1)

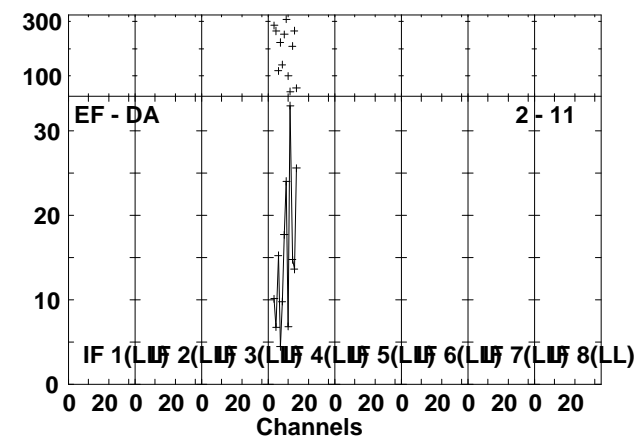
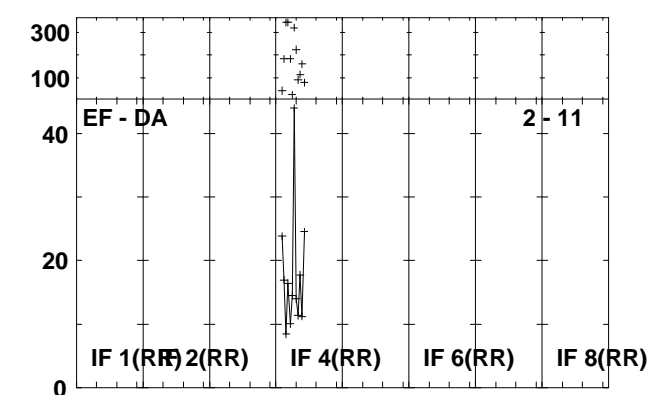
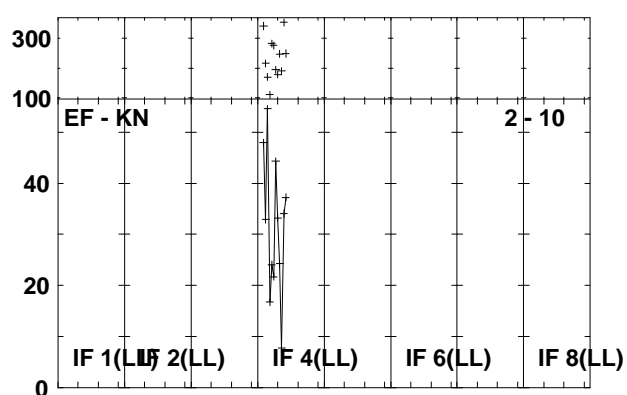
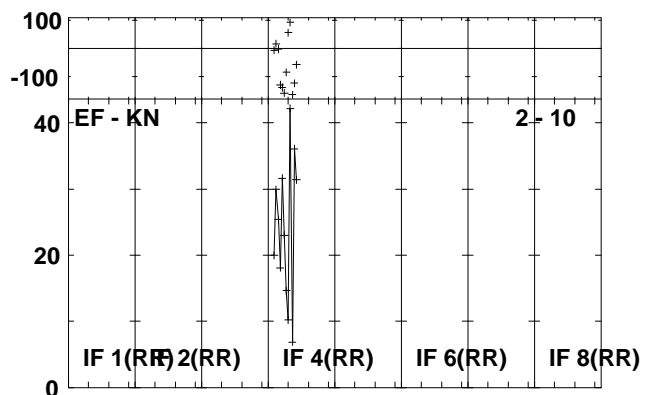
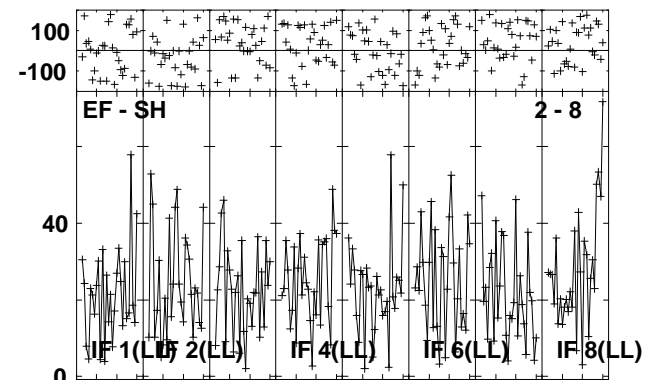
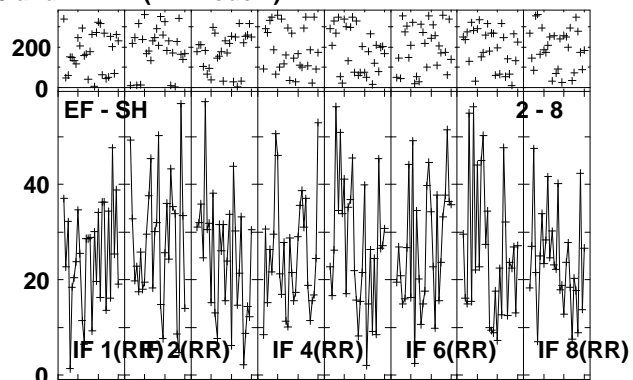
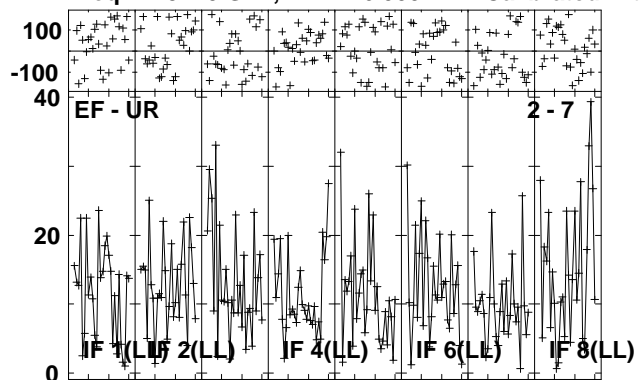

Lower frame: Milli Ampl Jy Top frame: Phas deg  
Vector averaged cross-power spectrum Several baselines displayed  
Timerange: 00/23:09:31 to 00/23:12:59

Plot file version 39 created 24-AUG-2010 08:16:25

J1941-05 EP064M.UVDATA.1

Freq = 4.9270 GHz, Bw = 16.000 MH Calibrated with CL # 3 and BP # 1 (BP mode 1)

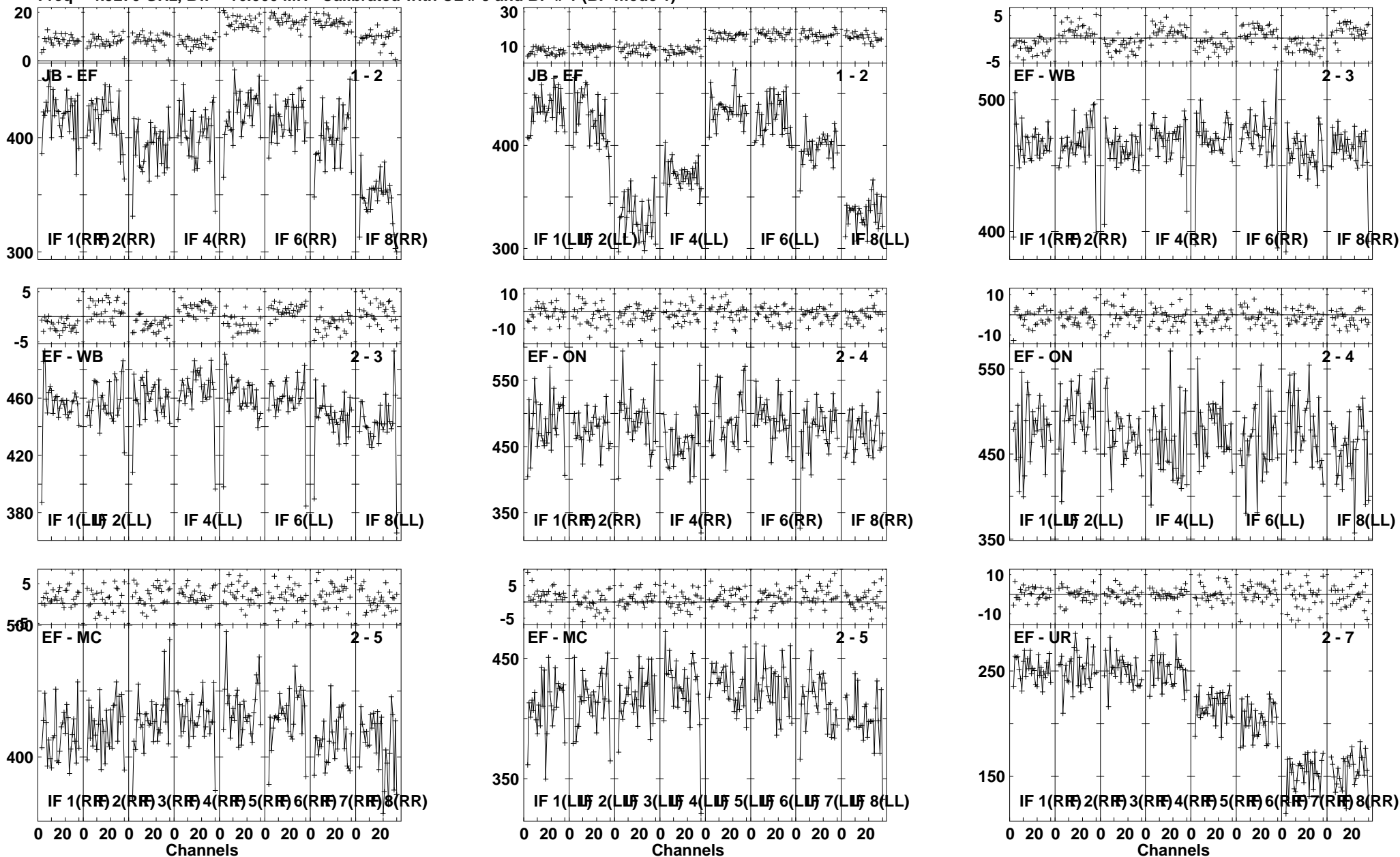

Lower frame: Milli Ampl Jy Top frame: Phas deg  
Vector averaged cross-power spectrum Several baselines displayed  
Timerange: 00/23:14:01 to 00/23:15:29

Plot file version 40 created 24-AUG-2010 08:16:27

J1941-05 EP064M.UVDATA.1

Freq = 4.9270 GHz, Bw = 16.000 MH Calibrated with CL # 3 and BP # 1 (BP mode 1)

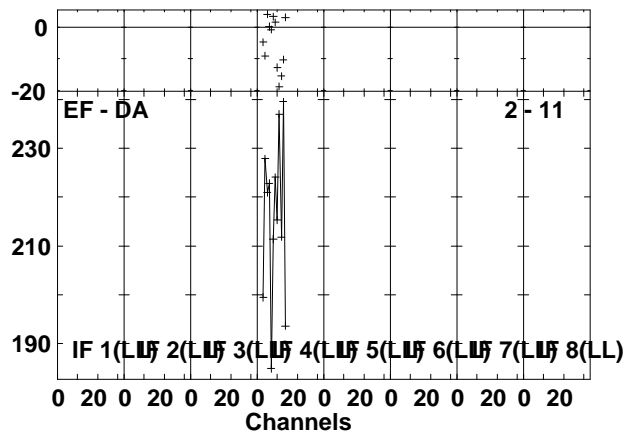
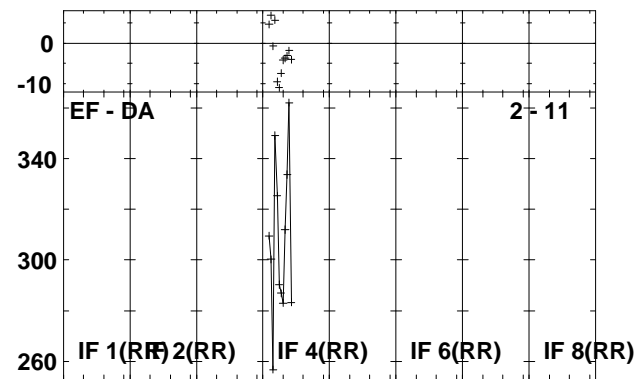
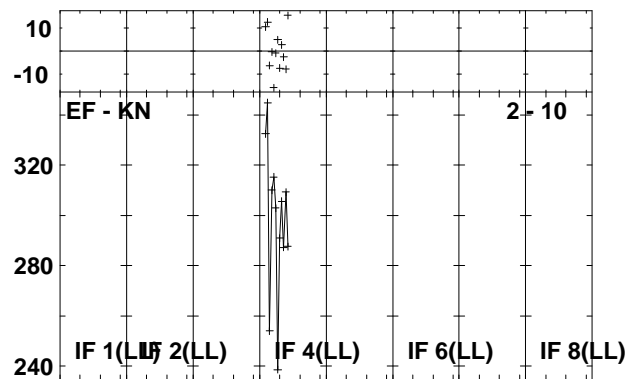
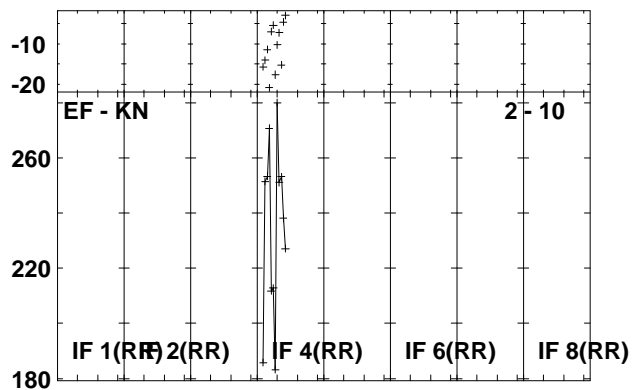
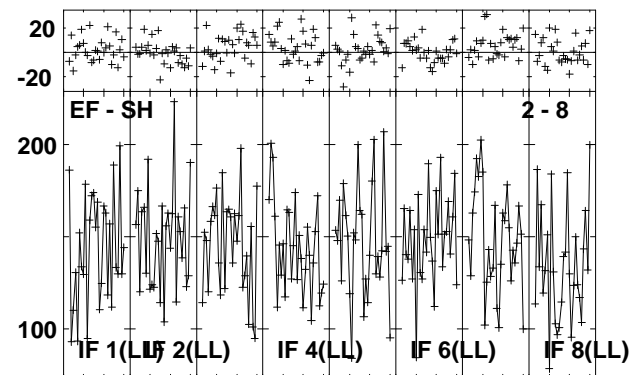
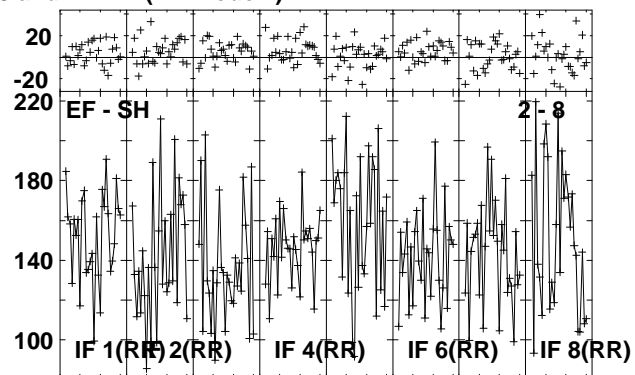
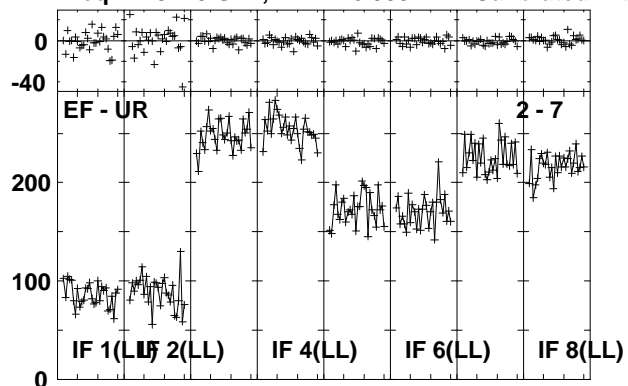

Lower frame: Milli Ampl Jy Top frame: Phas deg  
Vector averaged cross-power spectrum Several baselines displayed  
Timerange: 00/23:14:01 to 00/23:15:29



Plot file version 41 created 24-AUG-2010 08:16:29

IRAS1929 EP064M.UVDATA.1

Freq = 4.9270 GHz, Bw = 16.000 MH Calibrated with CL # 3 and BP # 1 (BP mode 1)

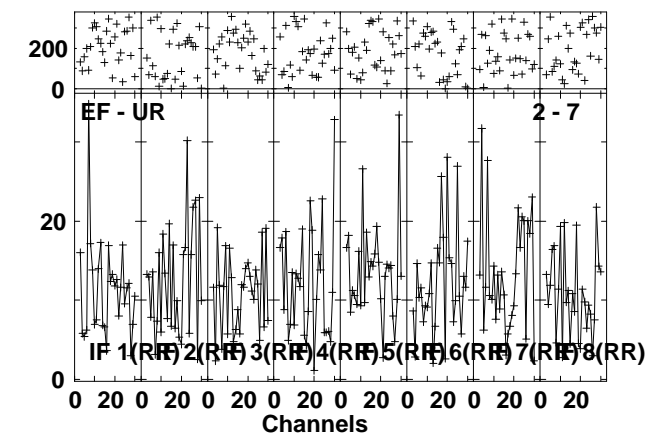
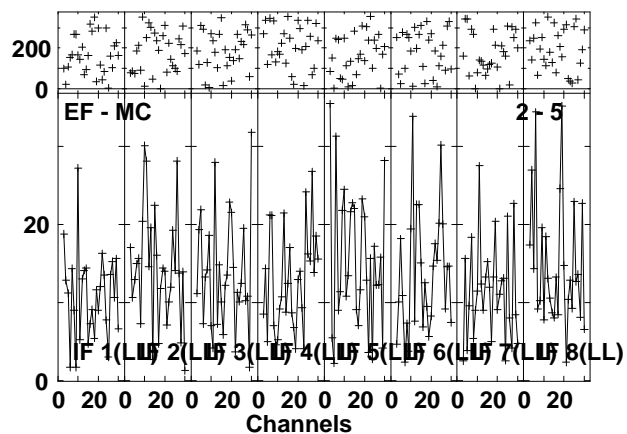
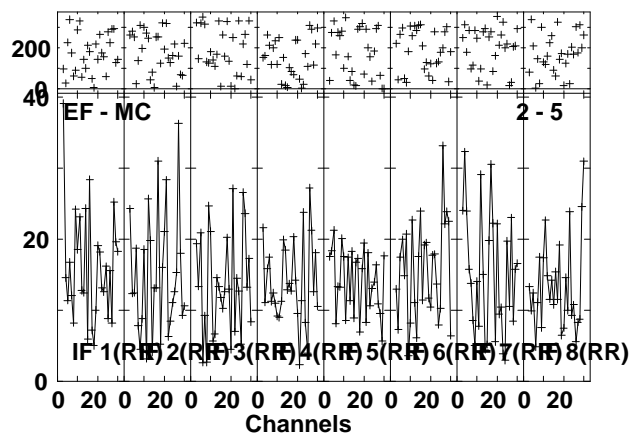
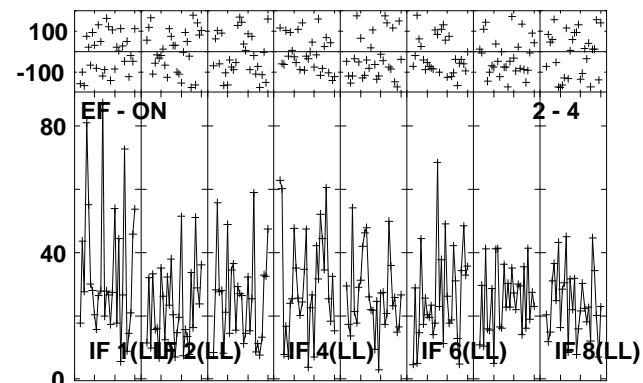
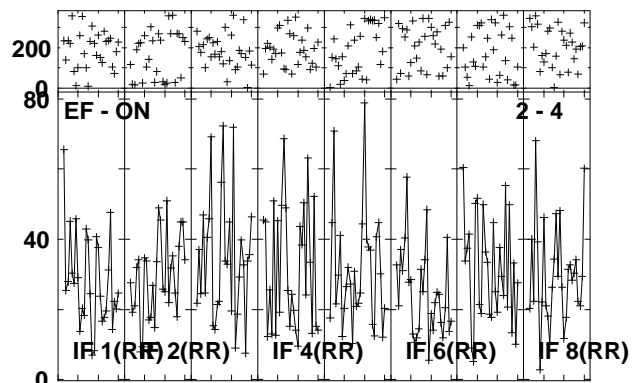
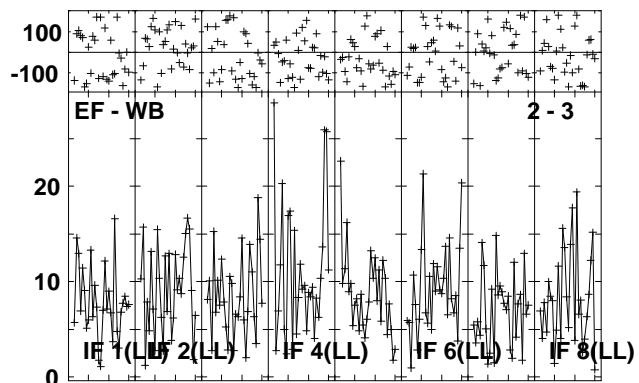
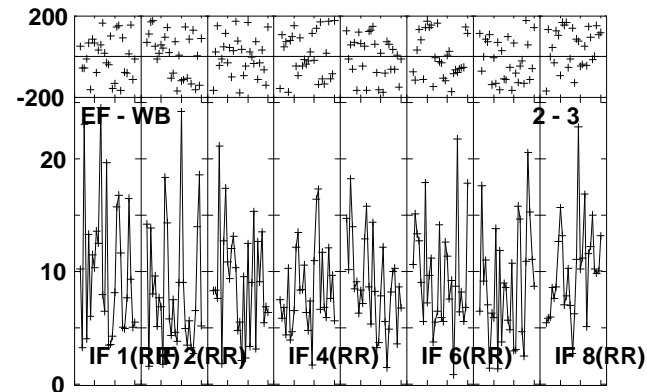
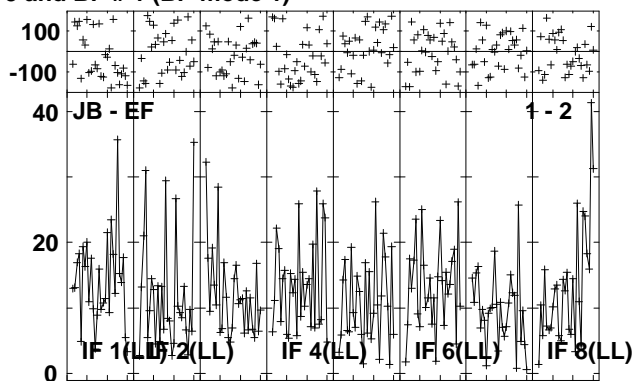
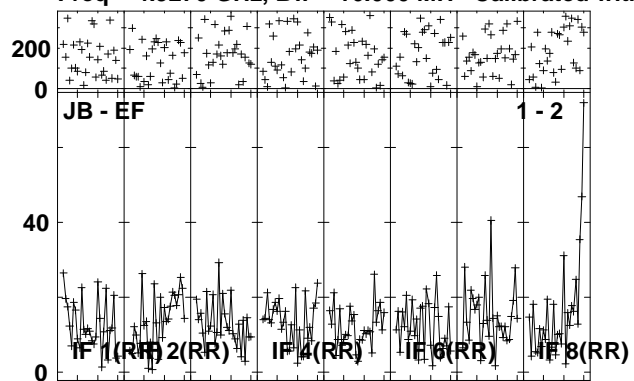

Lower frame: Milli Ampl Jy Top frame: Phas deg  
Vector averaged cross-power spectrum Several baselines displayed  
Timerange: 00/23:15:31 to 00/23:18:59

Plot file version 42 created 24-AUG-2010 08:16:32

IRAS1929 EP064M.UVDATA.1

Freq = 4.9270 GHz, Bw = 16.000 MH Calibrated with CL # 3 and BP # 1 (BP mode 1)

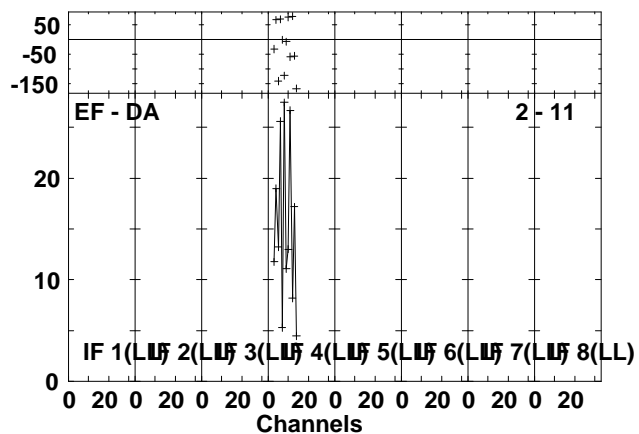
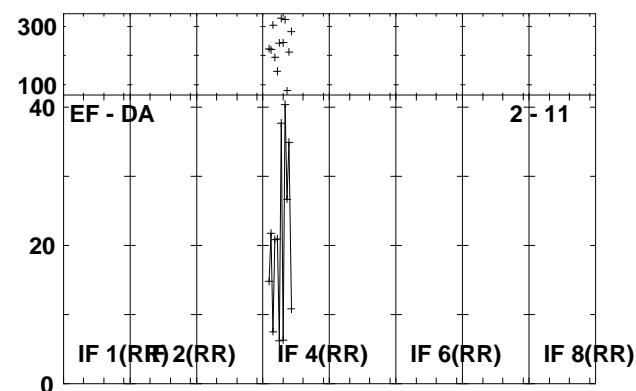
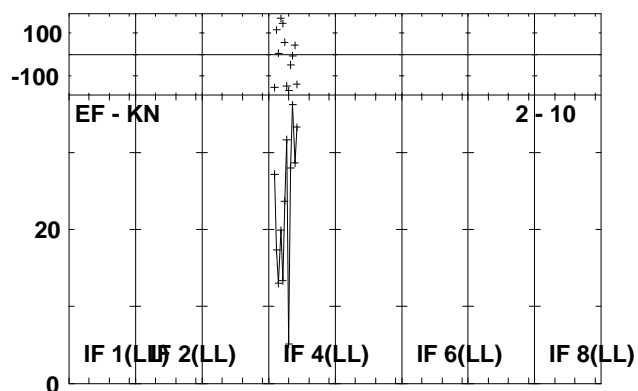
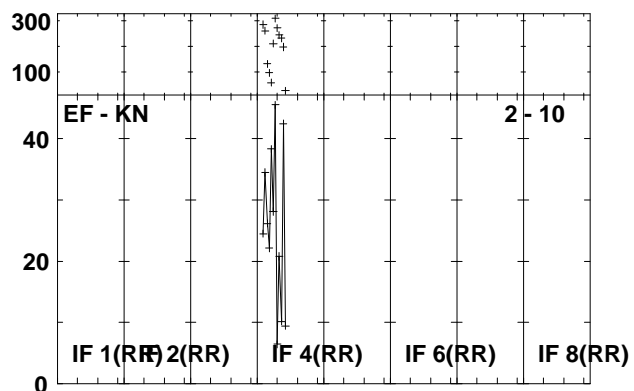
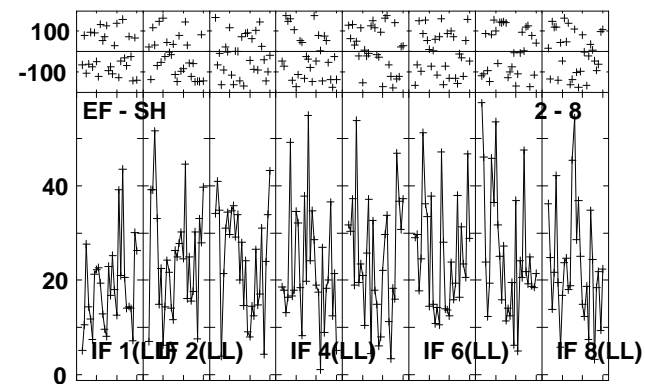
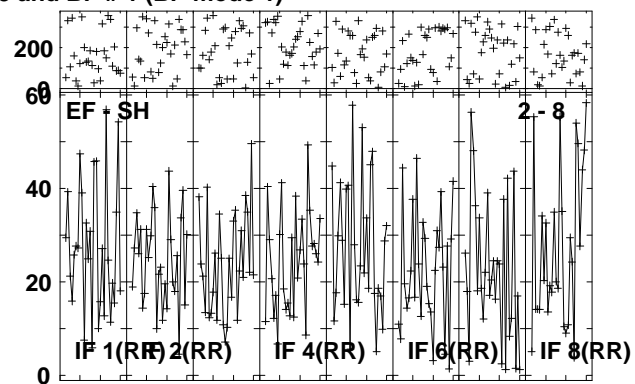
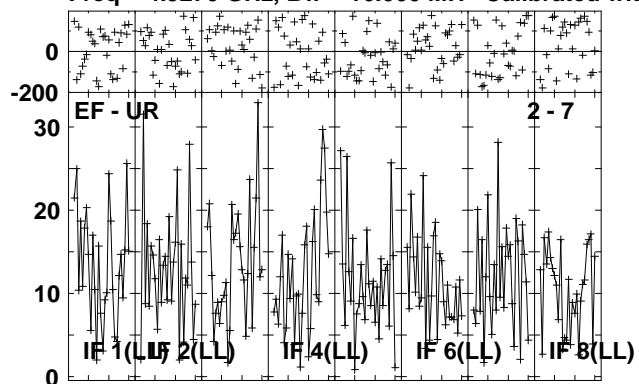

Lower frame: Milli Ampl Jy Top frame: Phas deg  
Vector averaged cross-power spectrum Several baselines displayed  
Timerange: 00/23:15:31 to 00/23:18:59

Plot file version 43 created 24-AUG-2010 08:16:36

J1941-05 EP064M.UVDATA.1

Freq = 4.9270 GHz, Bw = 16.000 MH Calibrated with CL # 3 and BP # 1 (BP mode 1)

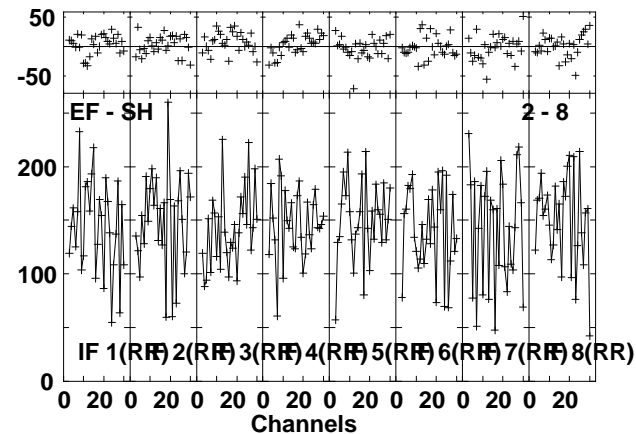
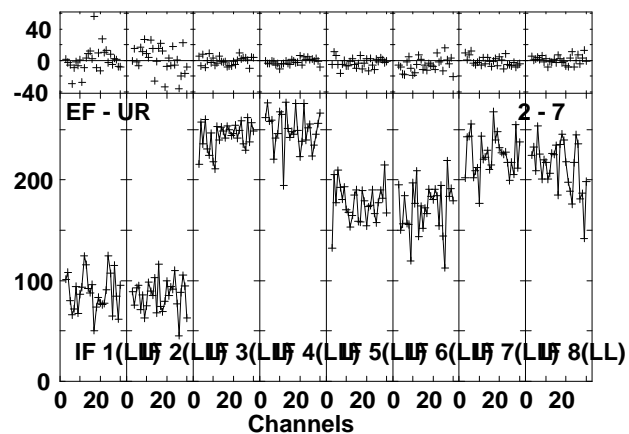
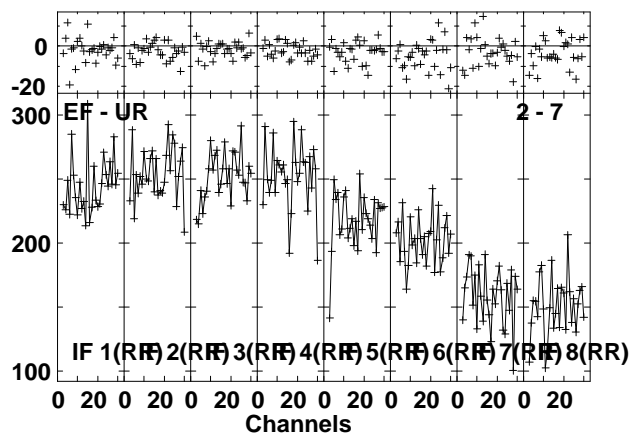
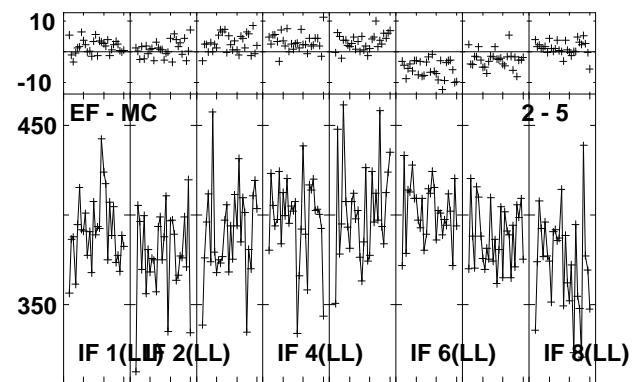
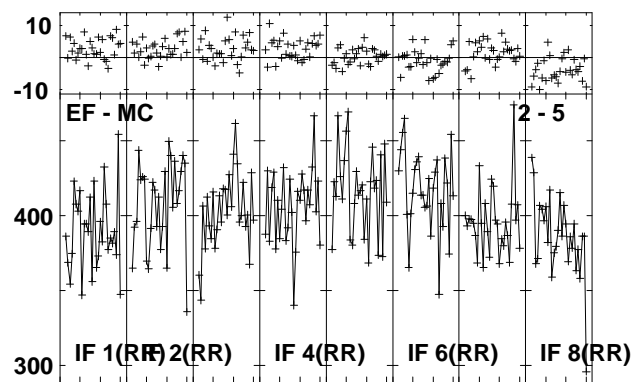
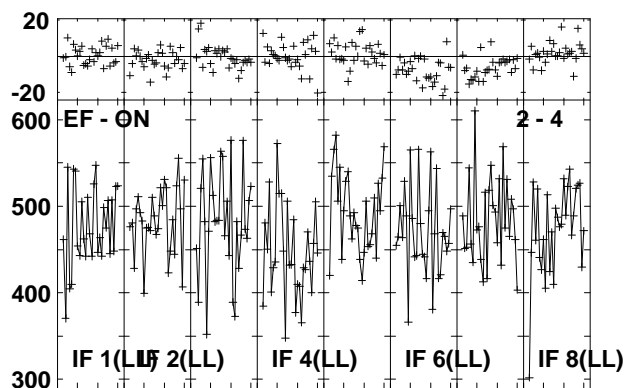
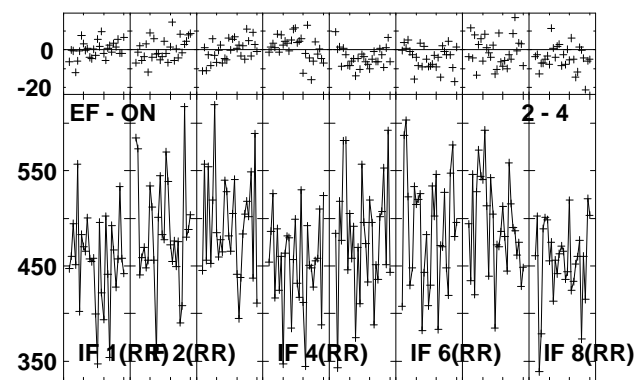
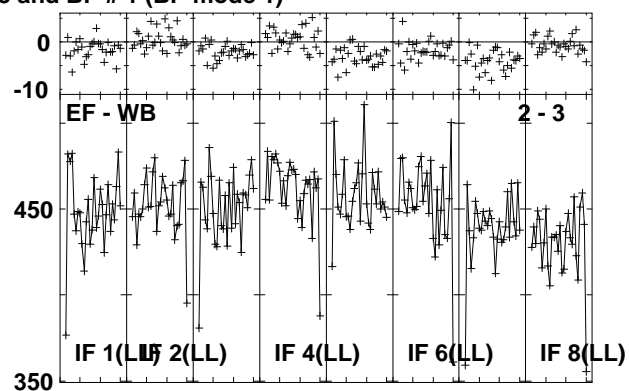
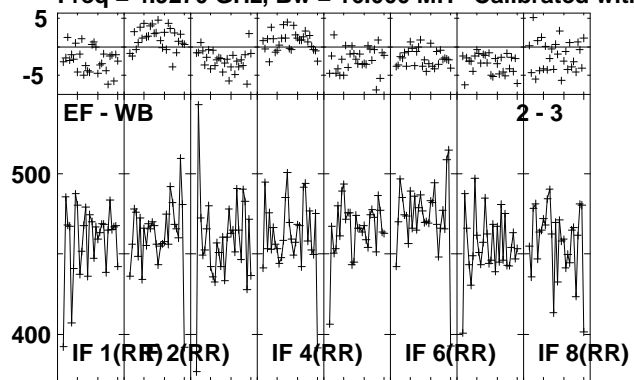

Lower frame: Milli Ampl Jy Top frame: Phas deg  
Vector averaged cross-power spectrum Several baselines displayed  
Timerange: 00/23:19:01 to 00/23:20:29

Plot file version 44 created 24-AUG-2010 08:16:37

J1941-05 EP064M.UVDATA.1

Freq = 4.9270 GHz, Bw = 16.000 MH Calibrated with CL # 3 and BP # 1 (BP mode 1)

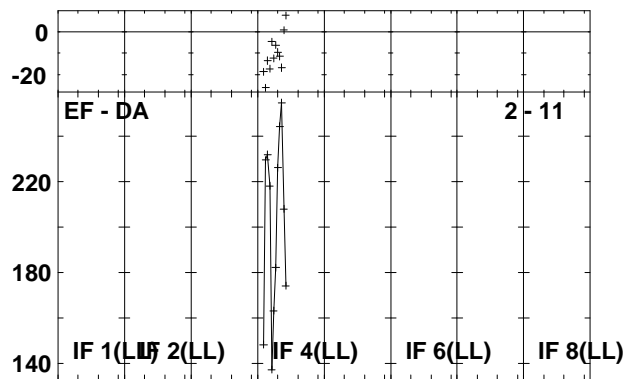
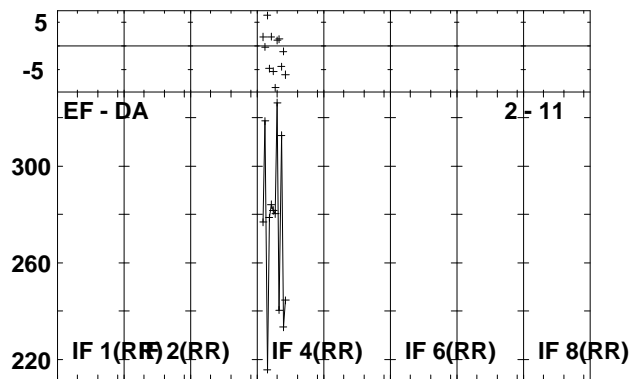
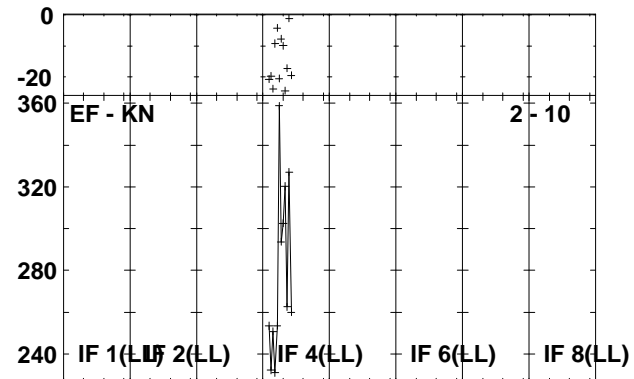
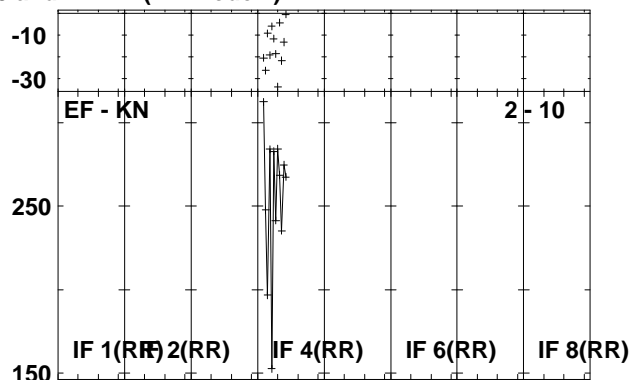
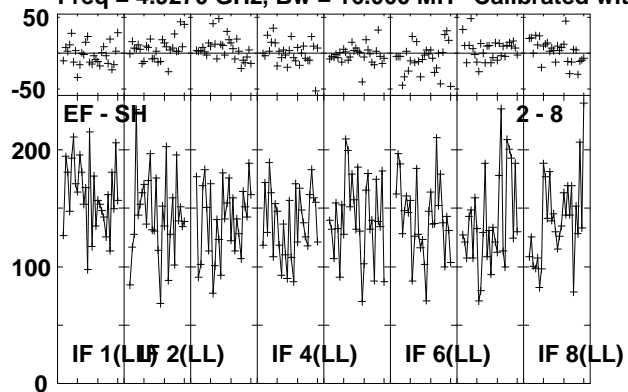

Lower frame: Milli Ampl Jy Top frame: Phas deg  
Vector averaged cross-power spectrum Several baselines displayed  
Timerange: 00/23:19:01 to 00/23:20:29

Plot file version 45 created 24-AUG-2010 08:16:38

IRAS1929 EP064M.UVDATA.1

Freq = 4.9270 GHz, Bw = 16.000 MH Calibrated with CL # 3 and BP # 1 (BP mode 1)

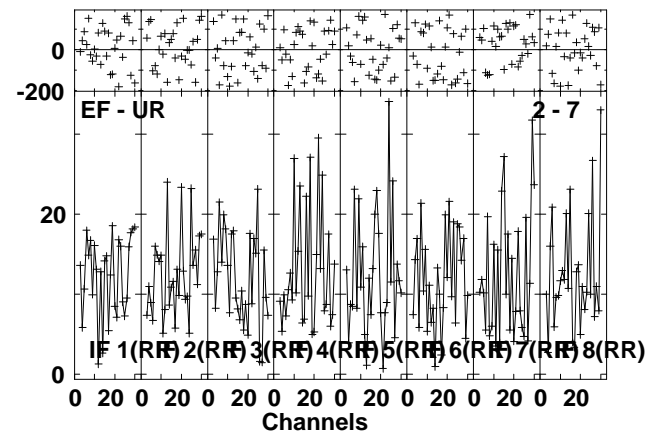
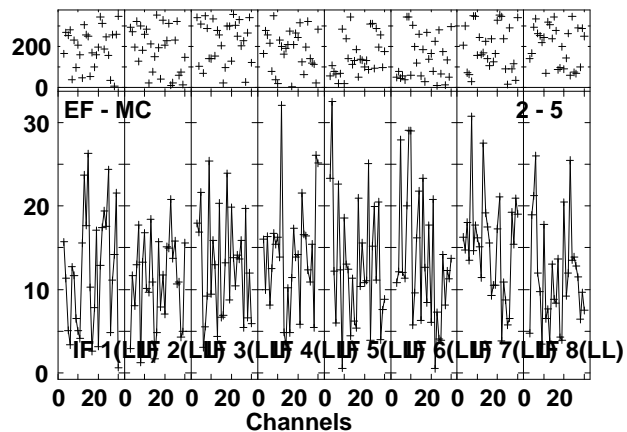
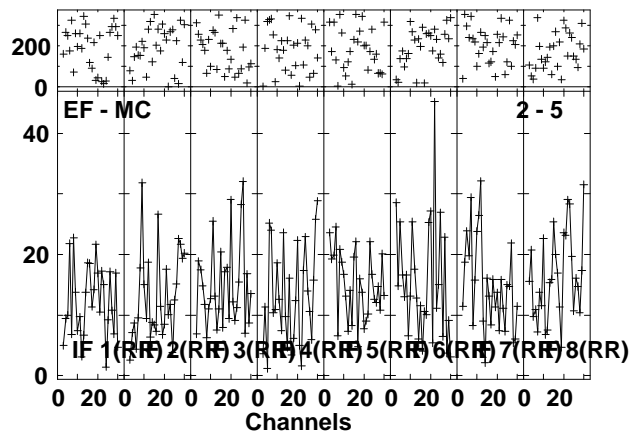
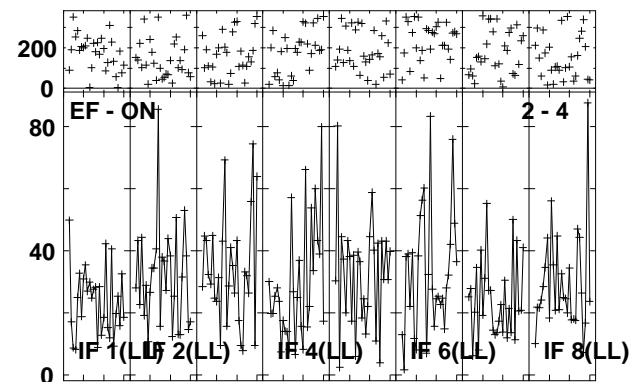
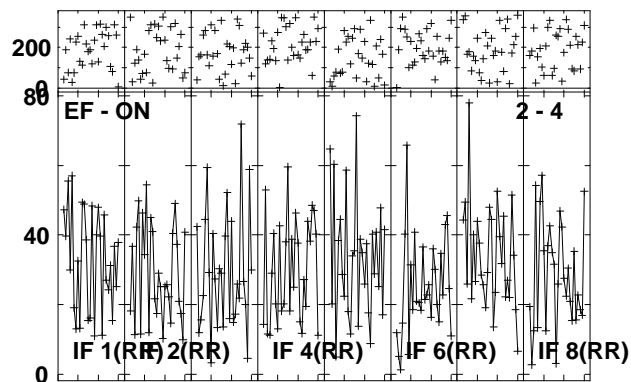
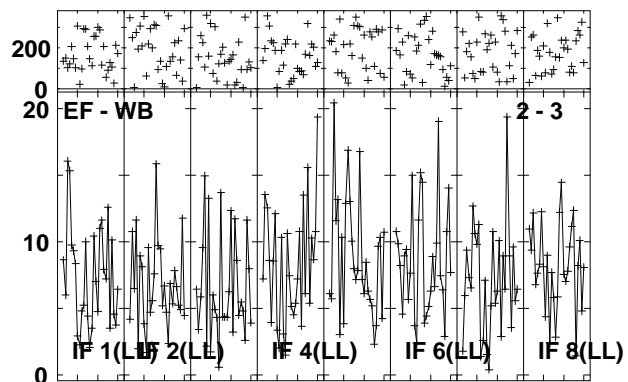
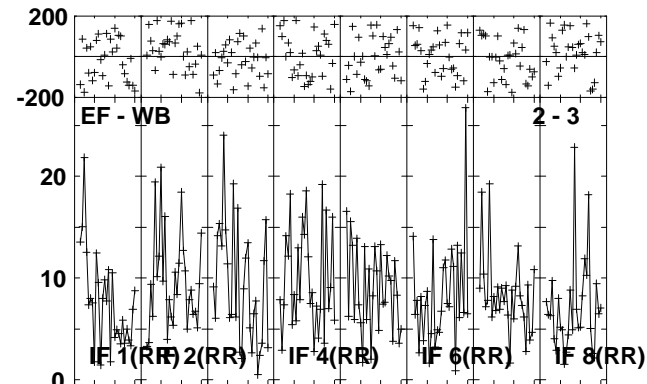
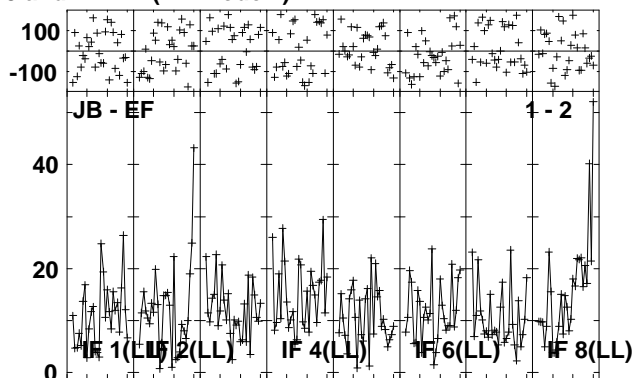
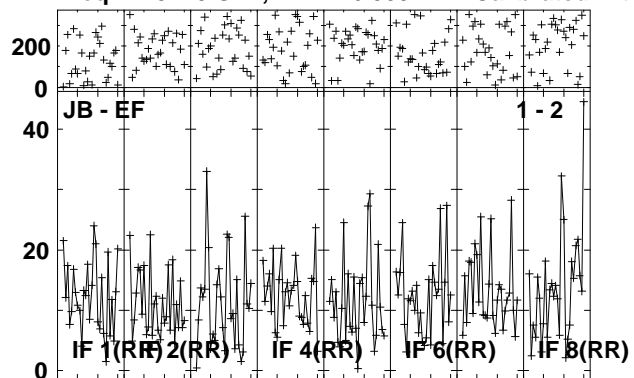

Lower frame: Milli Ampl Jy Top frame: Phas deg  
Vector averaged cross-power spectrum Several baselines displayed  
Timerange: 00/23:20:31 to 00/23:23:59

Plot file version 46 created 24-AUG-2010 08:16:42

IRAS1929 EP064M.UVDATA.1

Freq = 4.9270 GHz, Bw = 16.000 MH Calibrated with CL # 3 and BP # 1 (BP mode 1)

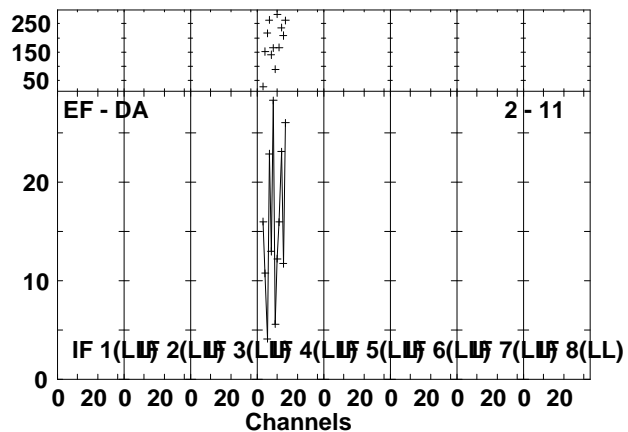
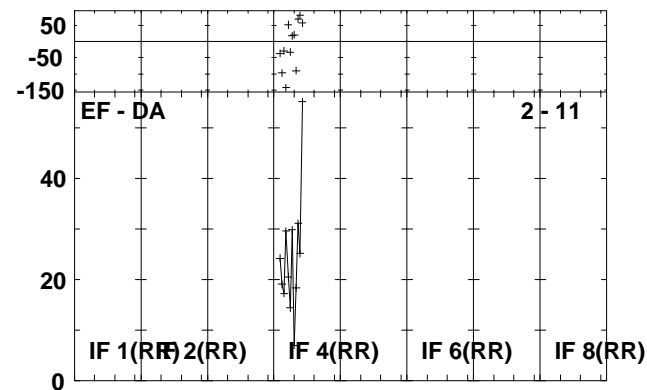
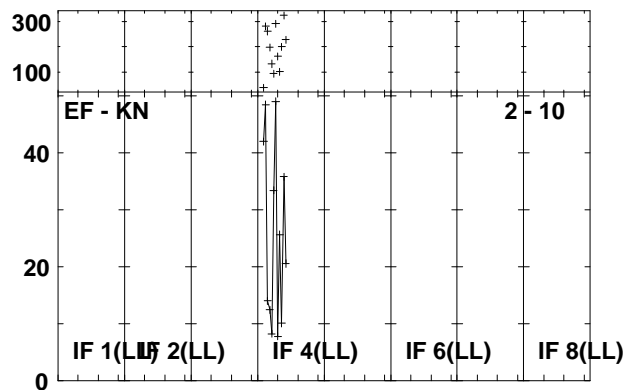
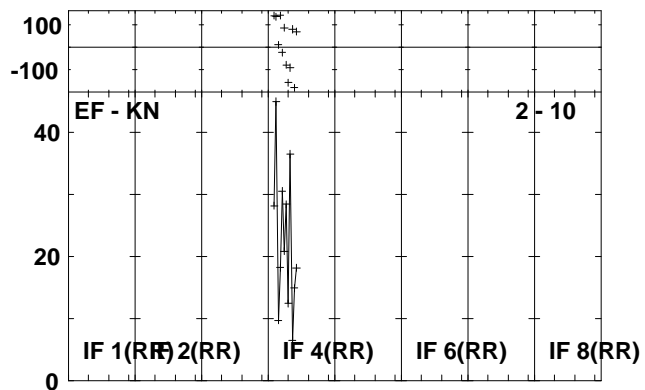
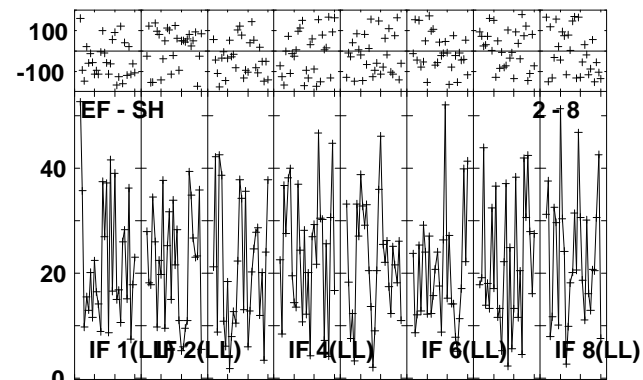
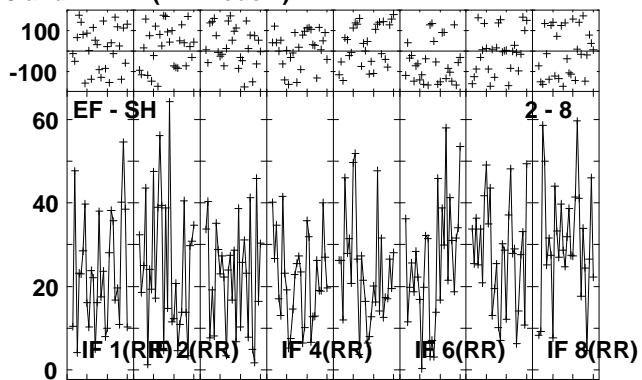
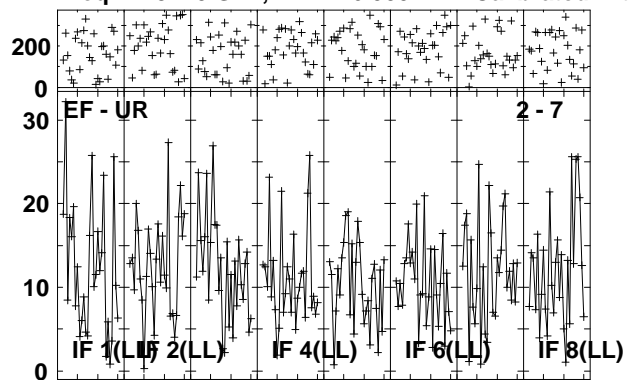

Lower frame: Milli Ampl Jy Top frame: Phas deg  
Vector averaged cross-power spectrum Several baselines displayed  
Timerange: 00/23:20:31 to 00/23:23:59

Plot file version 47 created 24-AUG-2010 08:16:45

J1941-05 EP064M.UVDATA.1

Freq = 4.9270 GHz, Bw = 16.000 MH Calibrated with CL # 3 and BP # 1 (BP mode 1)

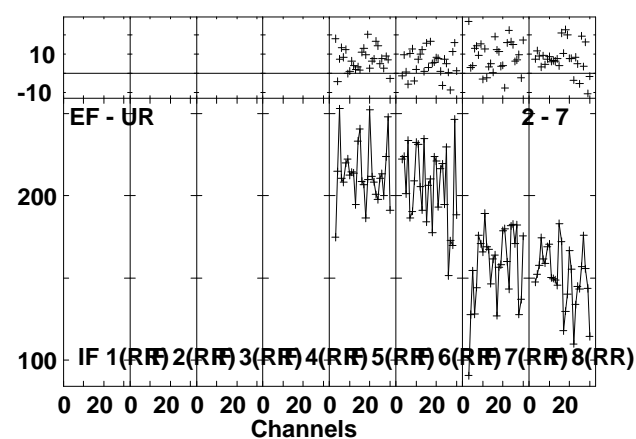
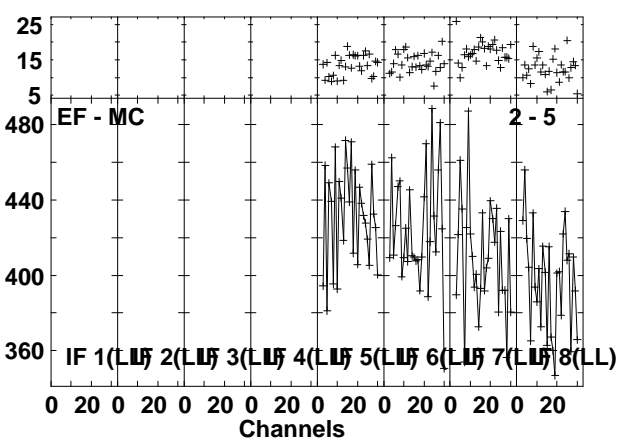
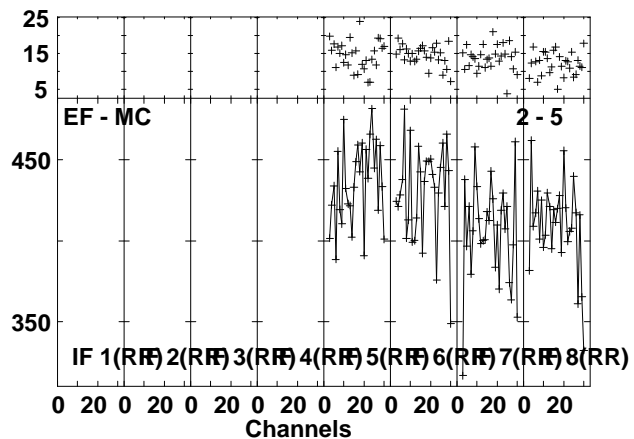
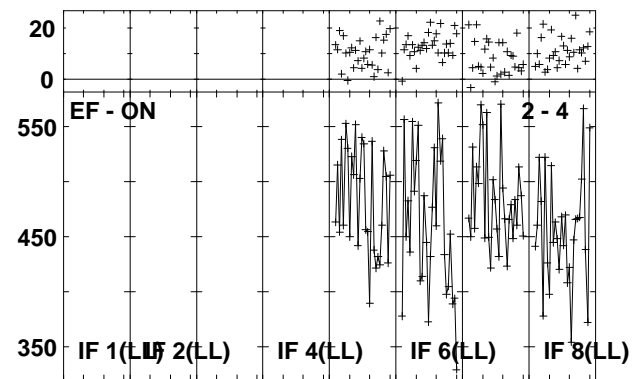
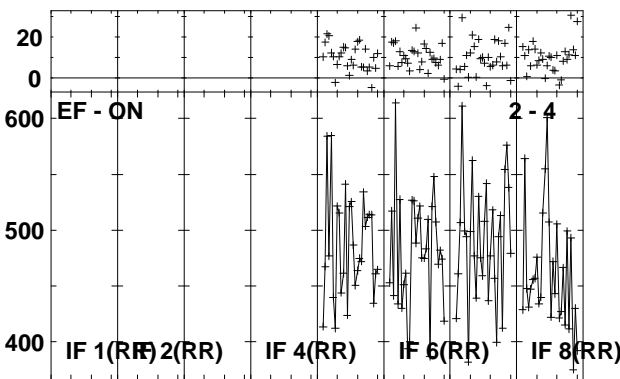
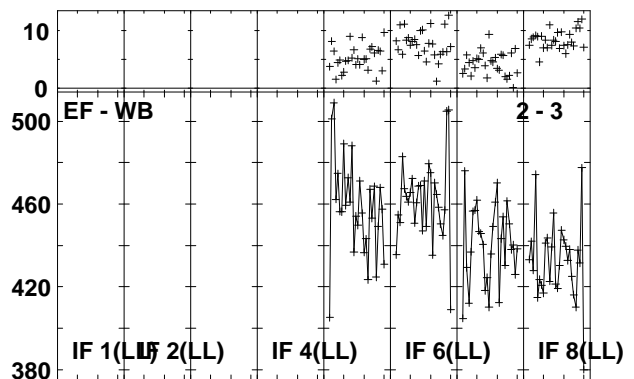
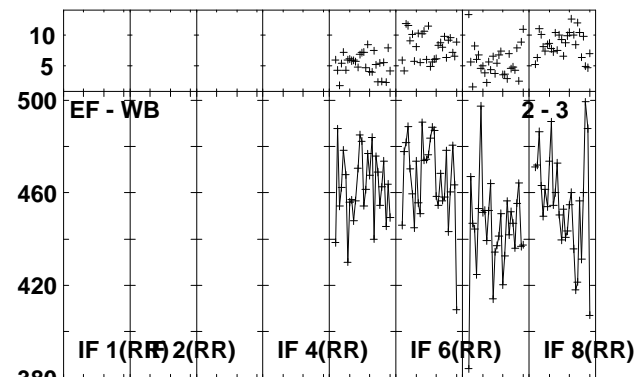
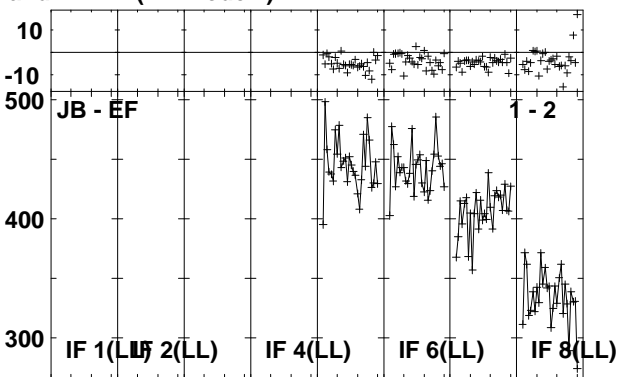
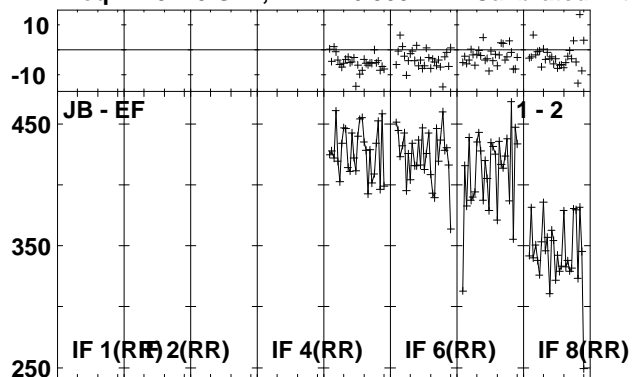

Lower frame: Milli Ampl Jy Top frame: Phas deg  
Vector averaged cross-power spectrum Several baselines displayed  
Timerange: 00/23:24:03 to 00/23:25:27

Plot file version 48 created 24-AUG-2010 08:16:46

J1941-05 EP064M.UVDATA.1

Freq = 4.9270 GHz, Bw = 16.000 MH Calibrated with CL # 3 and BP # 1 (BP mode 1)

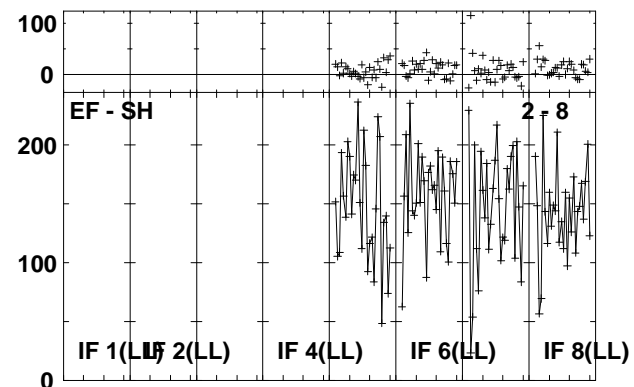
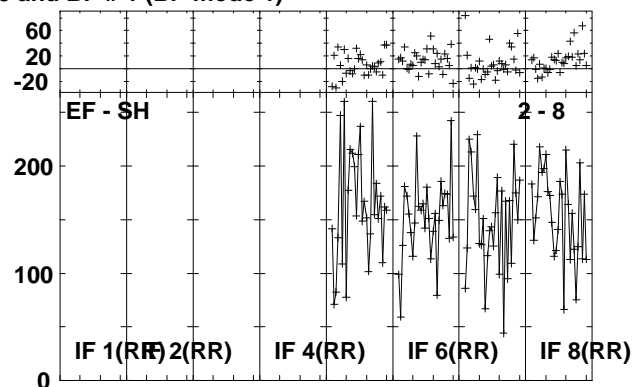
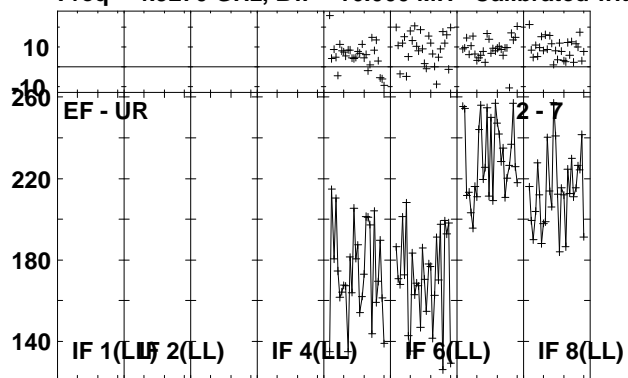

Lower frame: Milli Ampl Jy Top frame: Phas deg  
Vector averaged cross-power spectrum Several baselines displayed  
Timerange: 00/23:24:03 to 00/23:25:27



Plot file version 49 created 24-AUG-2010 08:16:48

IRAS1929 EP064M.UVDATA.1

Freq = 4.9270 GHz, Bw = 16.000 MH Calibrated with CL # 3 and BP # 1 (BP mode 1)

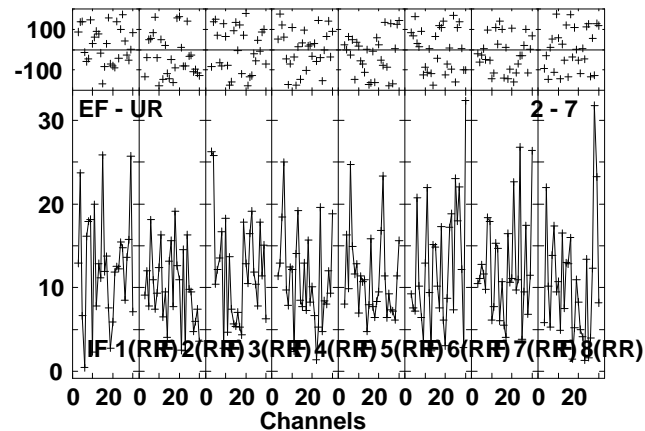
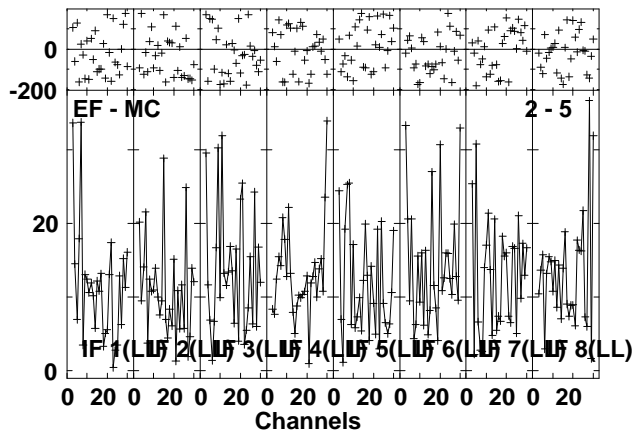
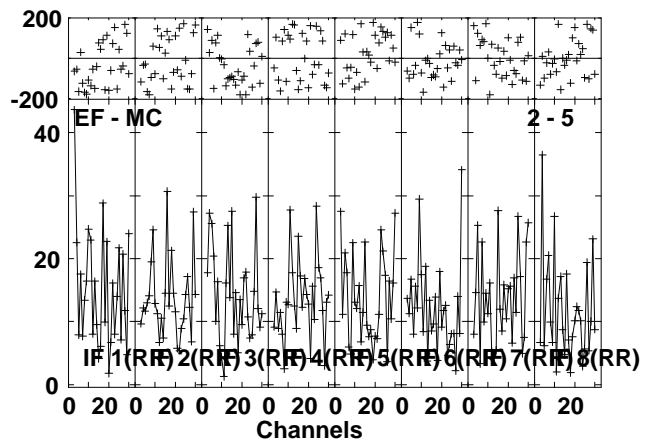
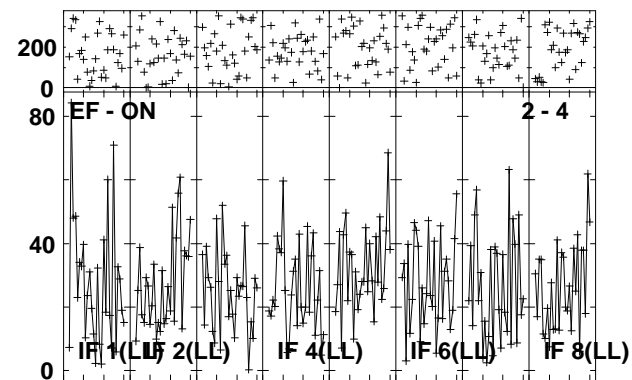
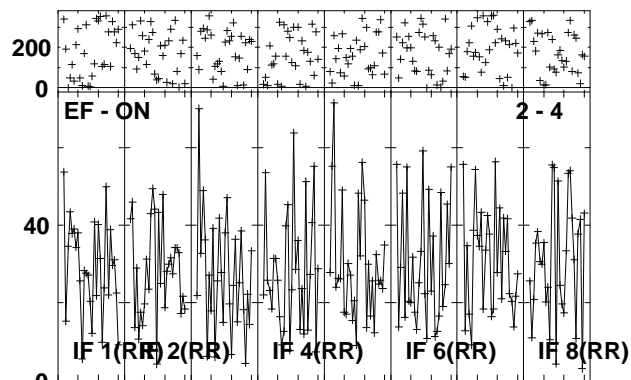
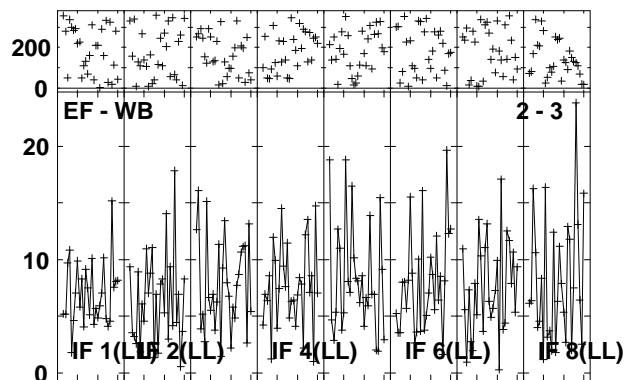
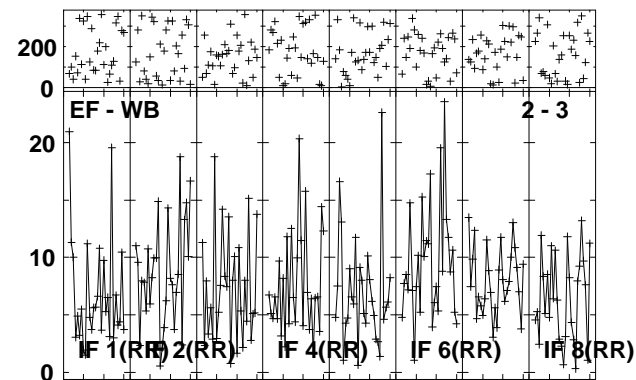
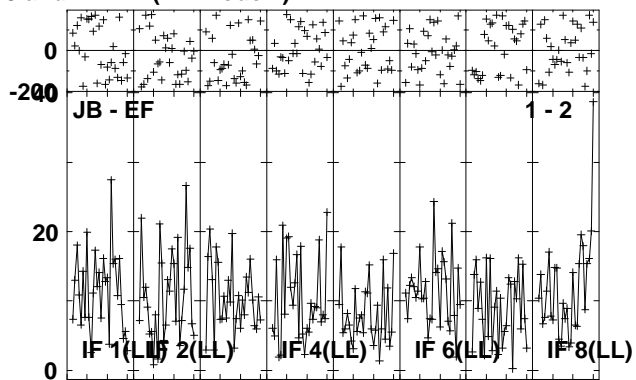
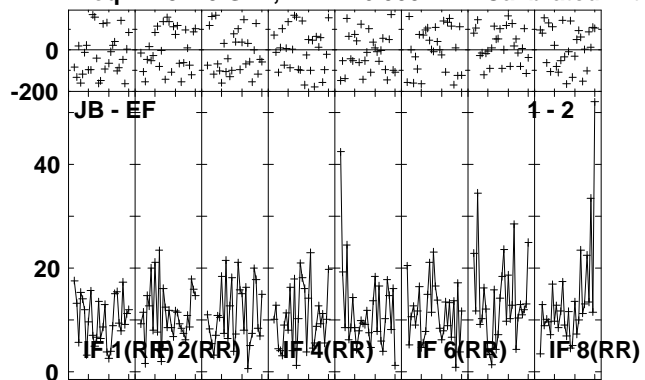

Lower frame: Milli Ampl Jy Top frame: Phas deg  
Vector averaged cross-power spectrum Several baselines displayed  
Timerange: 00/23:25:33 to 00/23:28:59

Plot file version 50 created 24-AUG-2010 08:16:51

IRAS1929 EP064M.UVDATA.1

Freq = 4.9270 GHz, Bw = 16.000 MH Calibrated with CL # 3 and BP # 1 (BP mode 1)

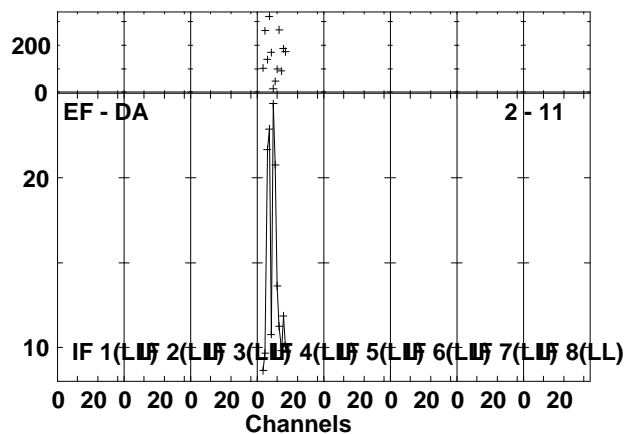
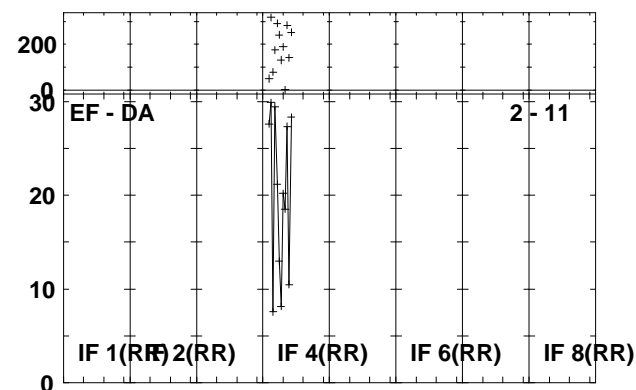
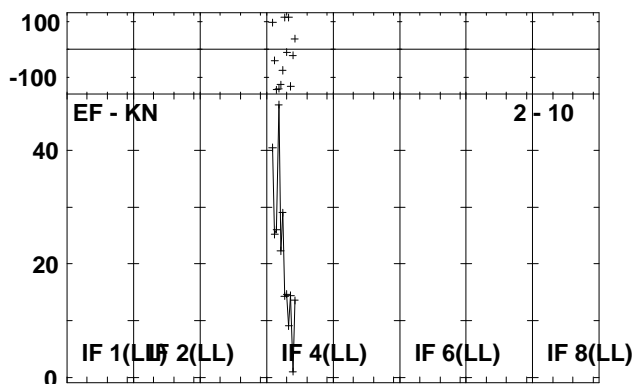
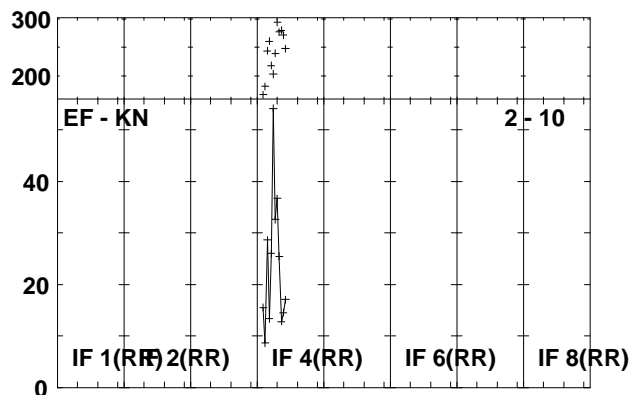
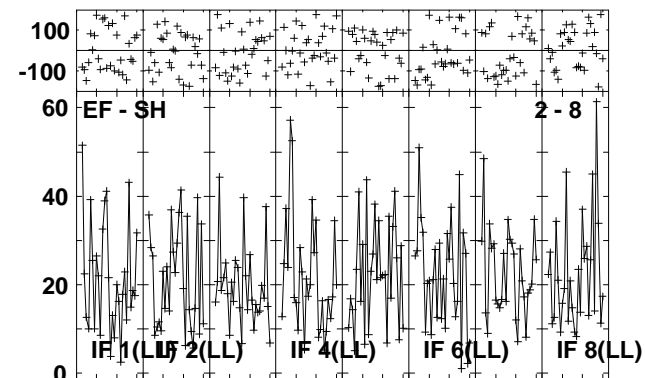
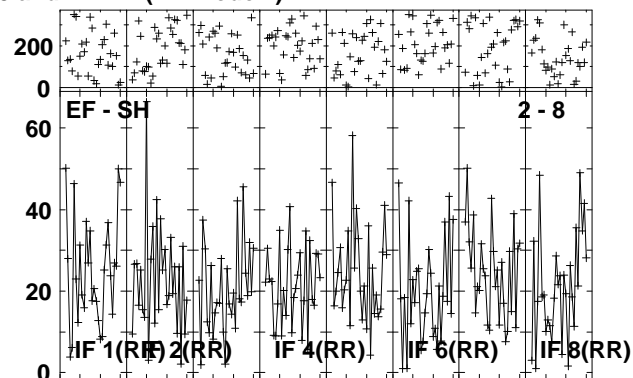
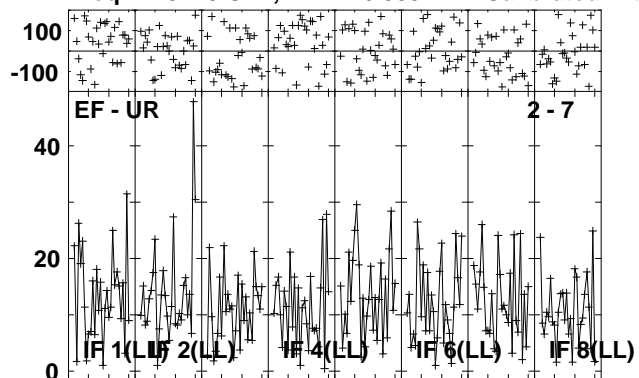

Lower frame: Milli Ampl Jy Top frame: Phas deg  
Vector averaged cross-power spectrum Several baselines displayed  
Timerange: 00/23:25:33 to 00/23:28:59

Plot file version 51 created 24-AUG-2010 08:16:54

J1941-05 EP064M.UVDATA.1

Freq = 4.9270 GHz, Bw = 16.000 MH Calibrated with CL # 3 and BP # 1 (BP mode 1)

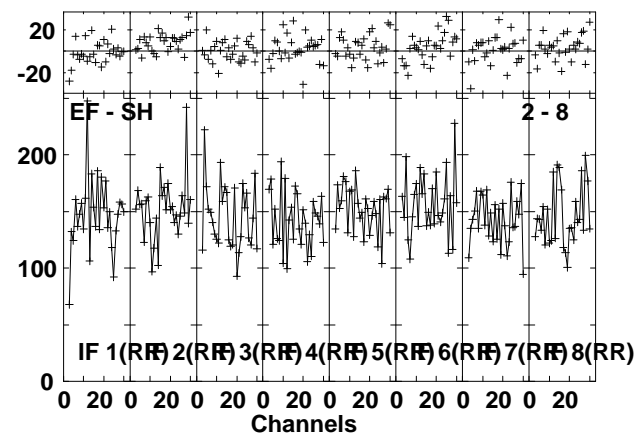
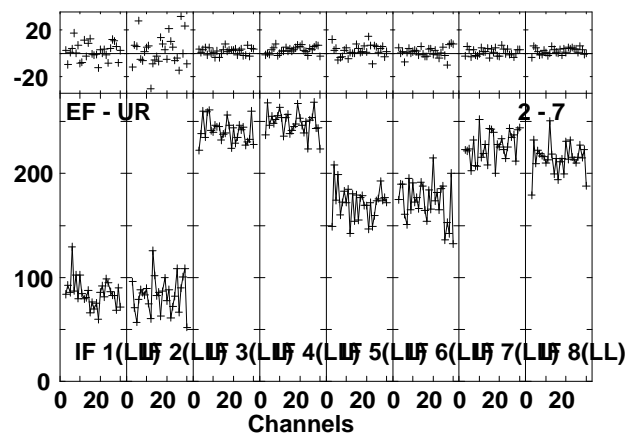
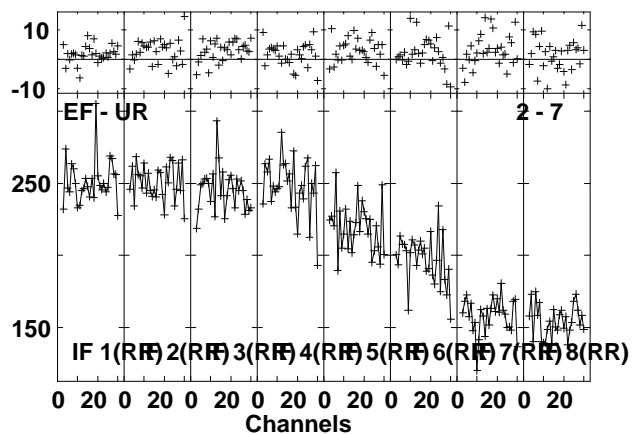
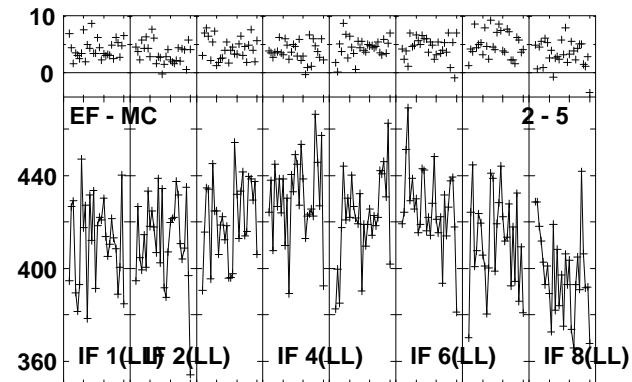
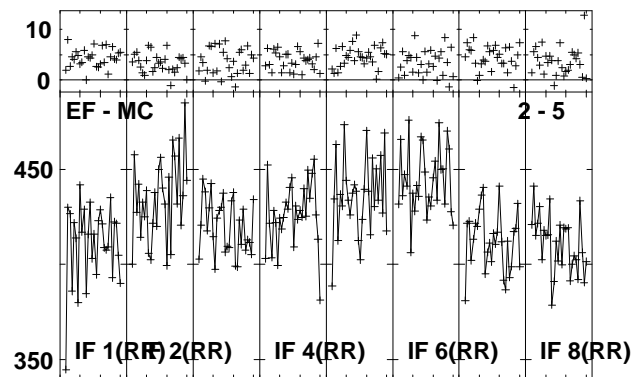
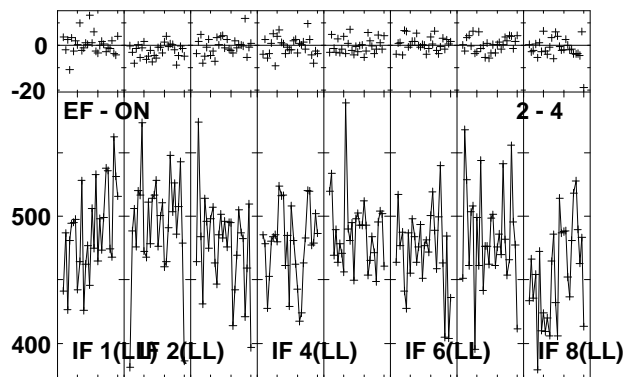
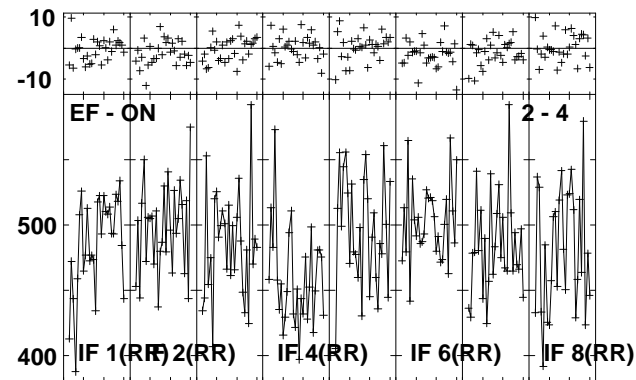
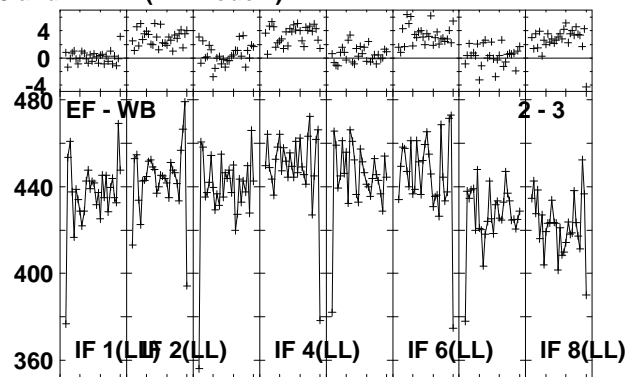
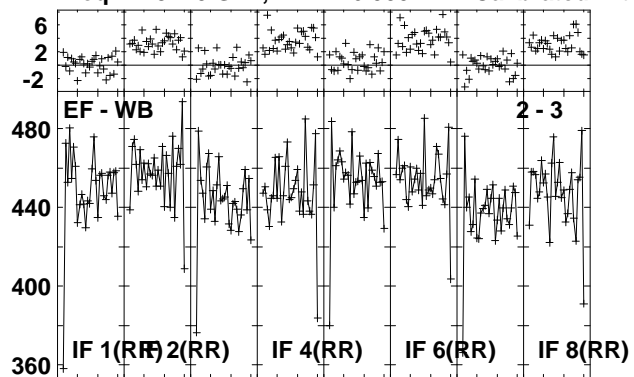

Lower frame: Milli Ampl Jy Top frame: Phas deg  
Vector averaged cross-power spectrum Several baselines displayed  
Timerange: 00/23:30:01 to 00/23:31:29

Plot file version 52 created 24-AUG-2010 08:16:55

J1941-05 EP064M.UVDATA.1

Freq = 4.9270 GHz, Bw = 16.000 MH Calibrated with CL # 3 and BP # 1 (BP mode 1)

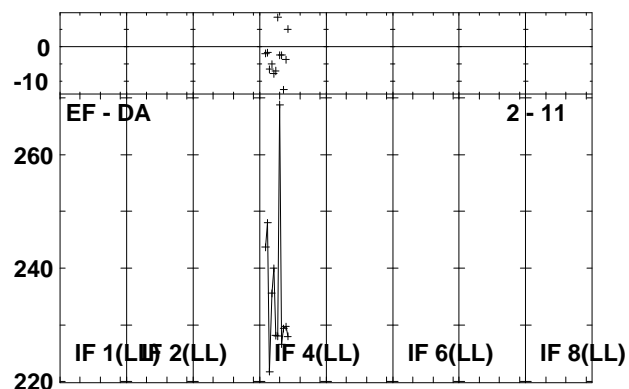
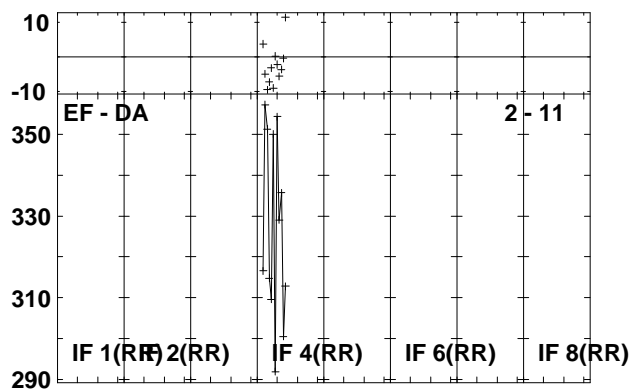
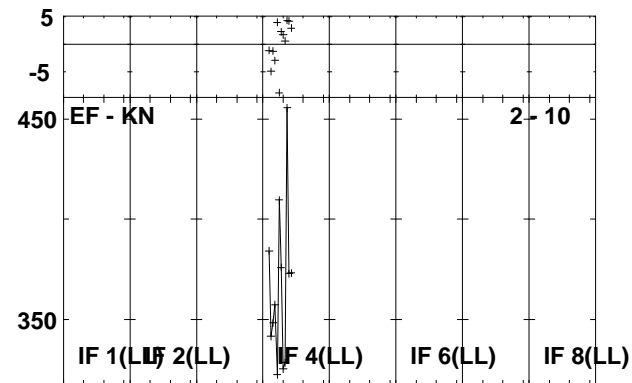
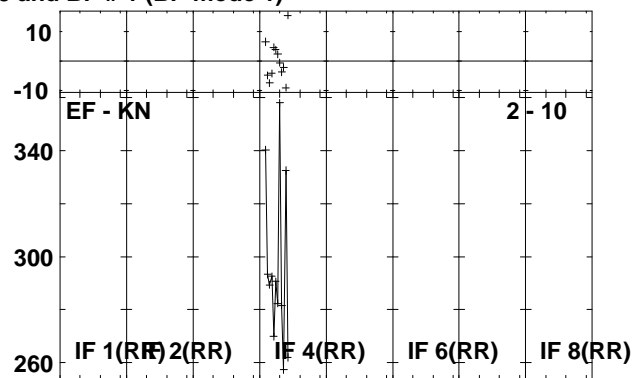
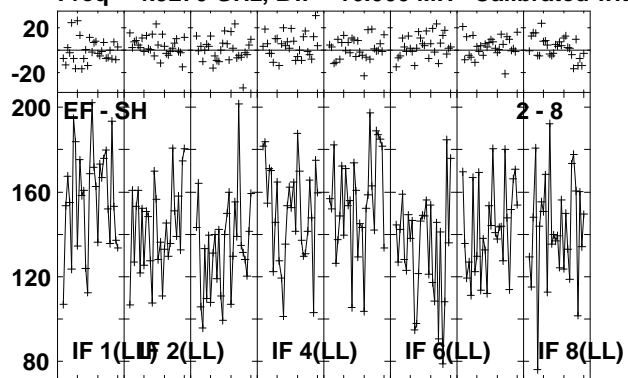

Lower frame: Milli Ampl Jy Top frame: Phas deg  
Vector averaged cross-power spectrum Several baselines displayed  
Timerange: 00/23:30:01 to 00/23:31:29

Plot file version 53 created 24-AUG-2010 08:16:57

IRAS1929 EP064M.UVDATA.1

Freq = 4.9270 GHz, Bw = 16.000 MH Calibrated with CL # 3 and BP # 1 (BP mode 1)

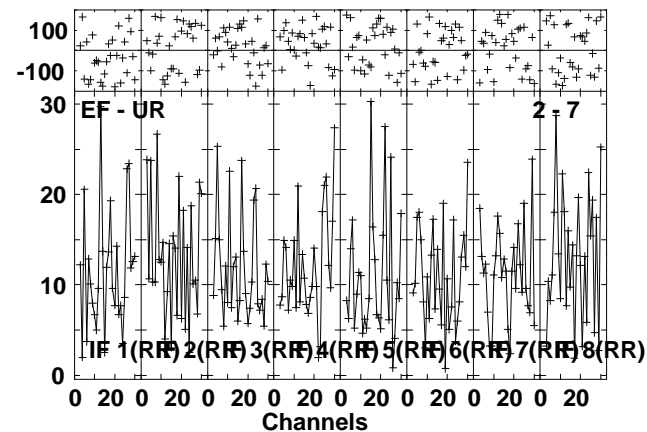
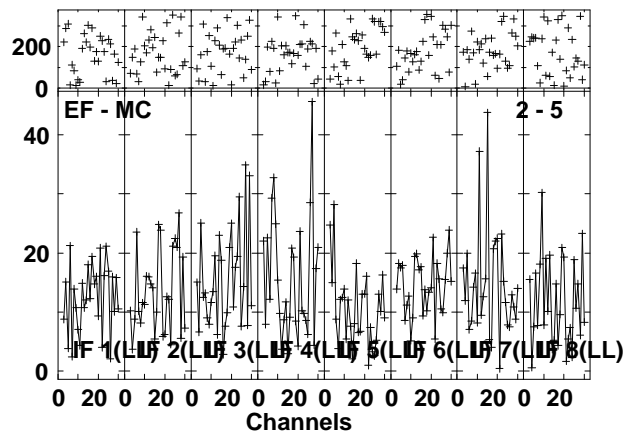
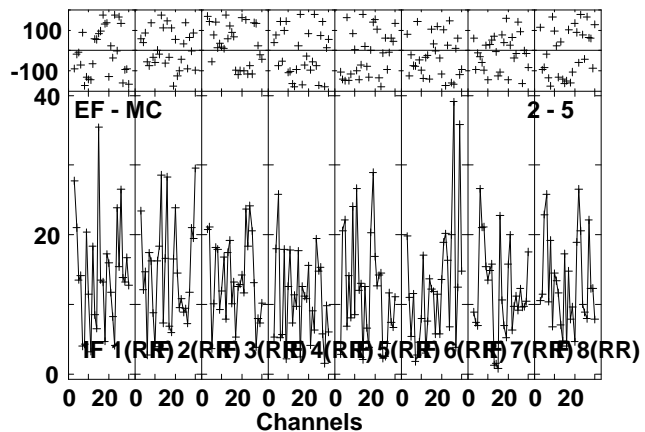
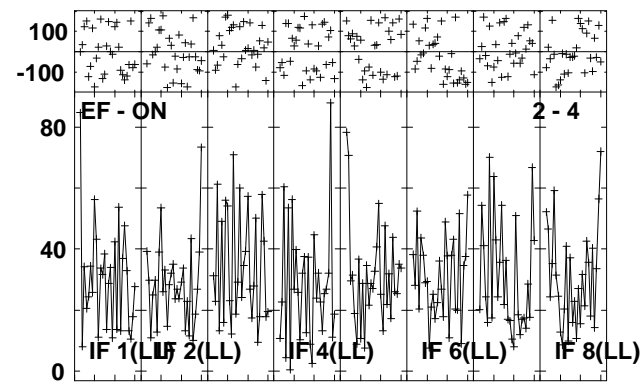
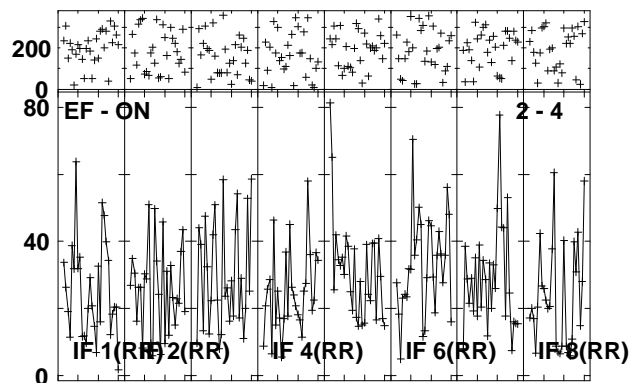
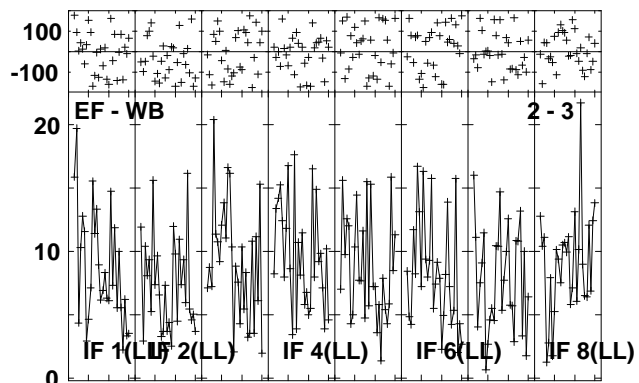
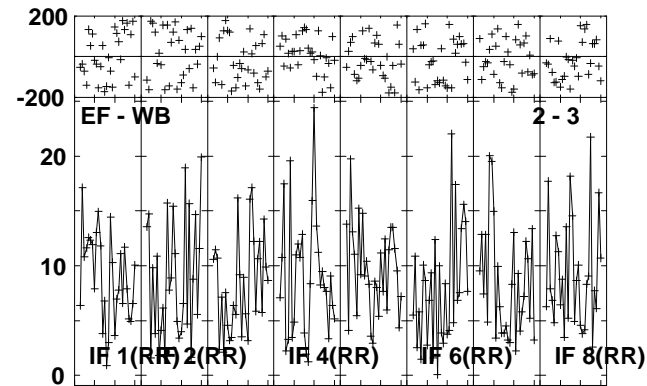
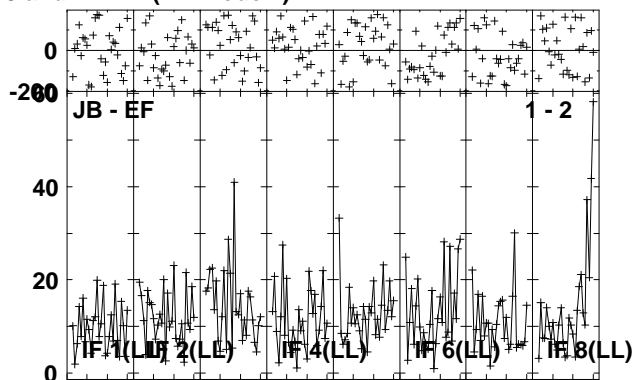
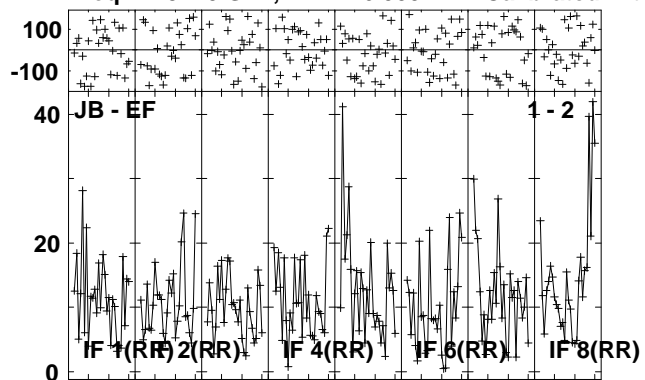

Lower frame: Milli Ampl Jy Top frame: Phas deg  
Vector averaged cross-power spectrum Several baselines displayed  
Timerange: 00/23:31:31 to 00/23:34:59

Plot file version 54 created 24-AUG-2010 08:17:00

IRAS1929 EP064M.UVDATA.1

Freq = 4.9270 GHz, Bw = 16.000 MH Calibrated with CL # 3 and BP # 1 (BP mode 1)

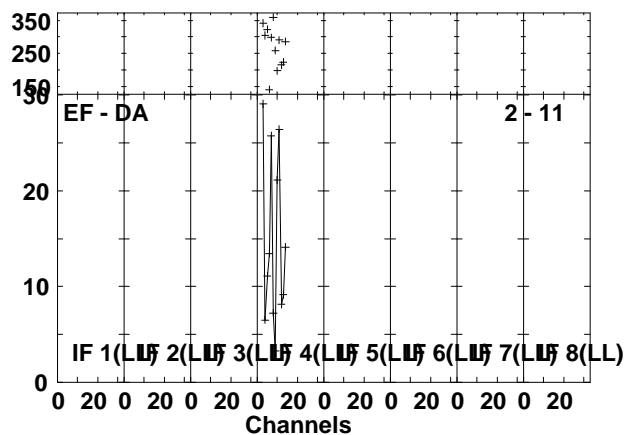
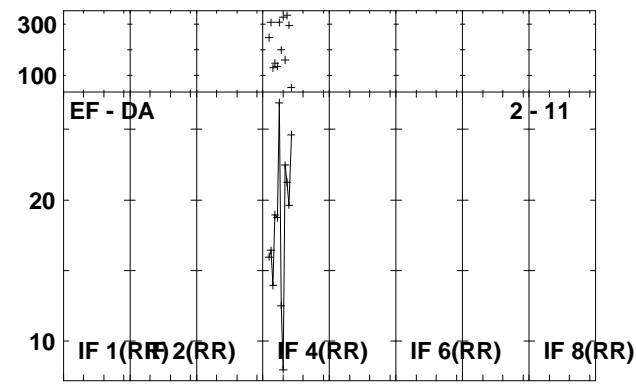
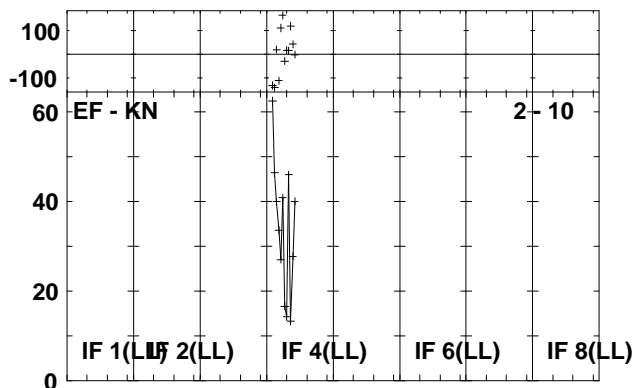
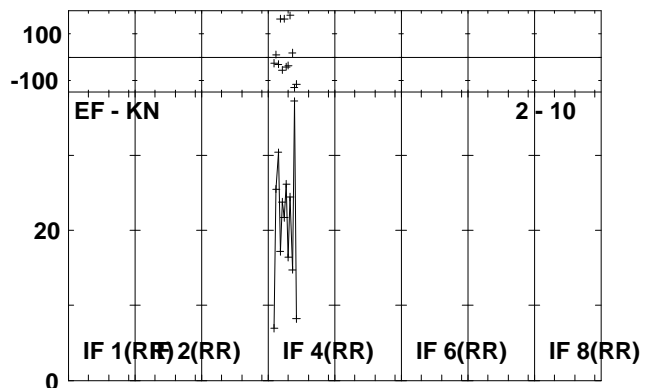
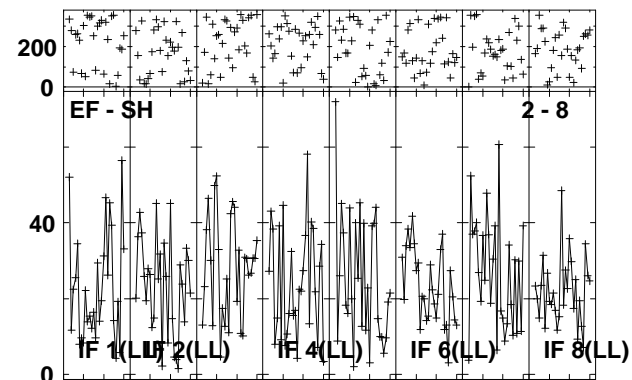
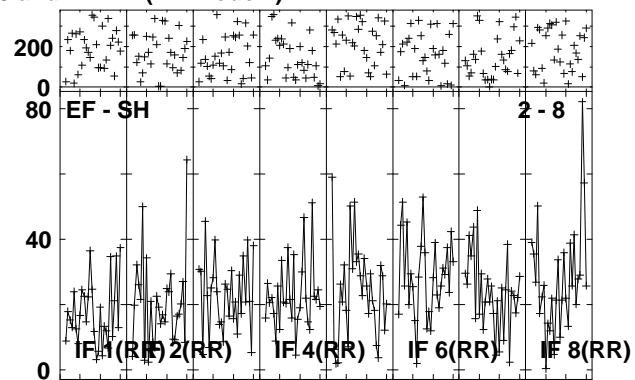
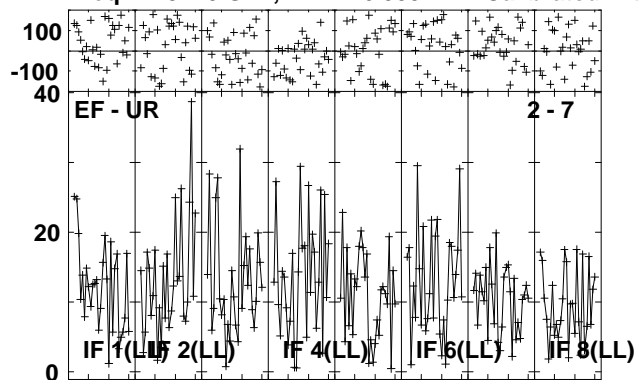

Lower frame: Milli Ampl Jy Top frame: Phas deg  
Vector averaged cross-power spectrum Several baselines displayed  
Timerange: 00/23:31:31 to 00/23:34:59

Plot file version 55 created 24-AUG-2010 08:17:04

J1941-05 EP064M.UVDATA.1

Freq = 4.9270 GHz, Bw = 16.000 MH Calibrated with CL # 3 and BP # 1 (BP mode 1)

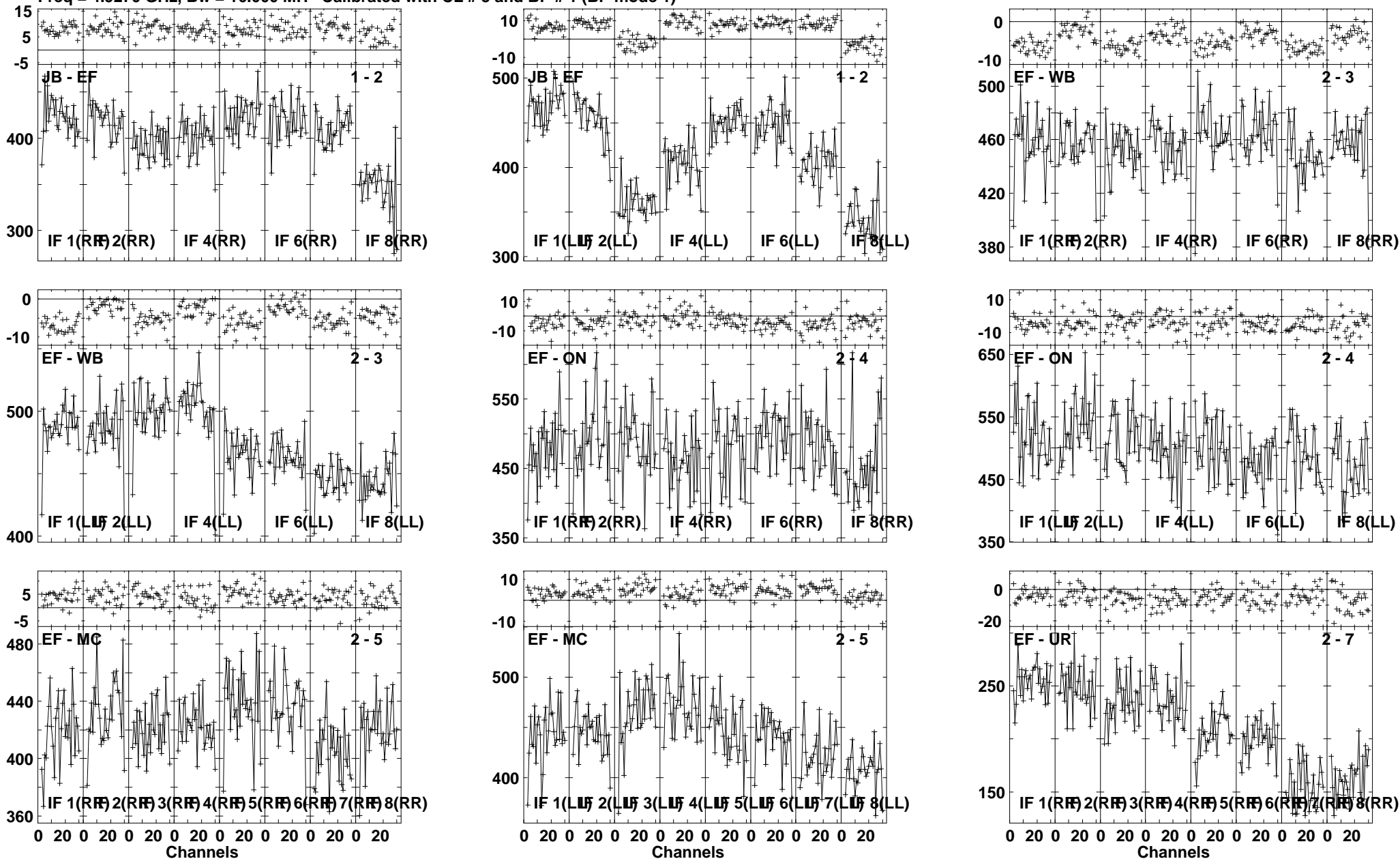

Lower frame: Milli Ampl Jy Top frame: Phas deg  
Vector averaged cross-power spectrum Several baselines displayed  
Timerange: 00/23:35:01 to 00/23:36:29





Plot file version 57 created 24-AUG-2010 08:17:07

IRAS1929 EP064M.UVDATA.1

Freq = 4.9270 GHz, Bw = 16.000 MH Calibrated with CL # 3 and BP # 1 (BP mode 1)

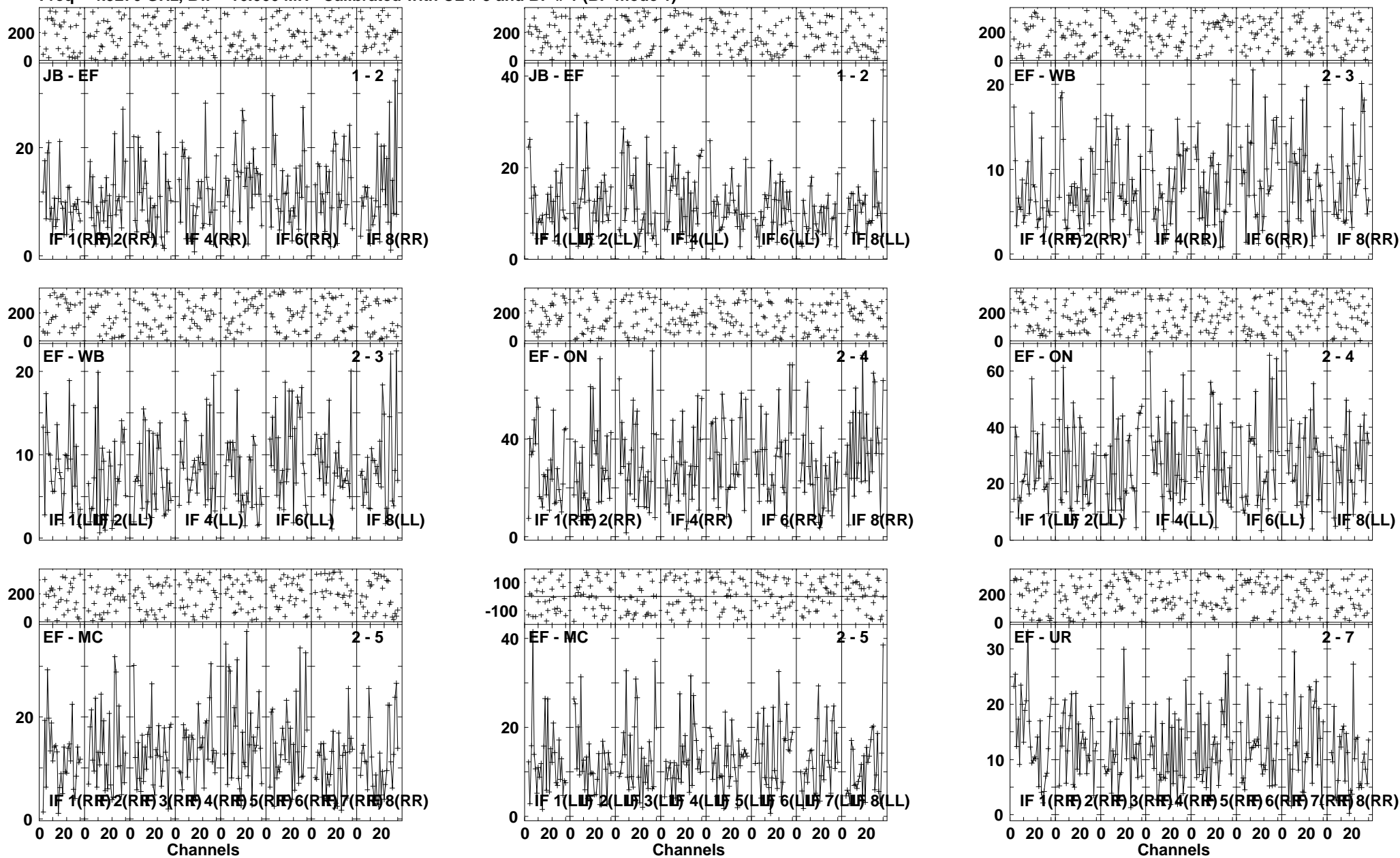

Lower frame: Milli Ampl Jy Top frame: Phas deg  
Vector averaged cross-power spectrum Several baselines displayed  
Timerange: 00/23:36:31 to 00/23:39:59

Plot file version 58 created 24-AUG-2010 08:17:10

IRAS1929 EP064M.UVDATA.1

Freq = 4.9270 GHz, Bw = 16.000 MH Calibrated with CL # 3 and BP # 1 (BP mode 1)

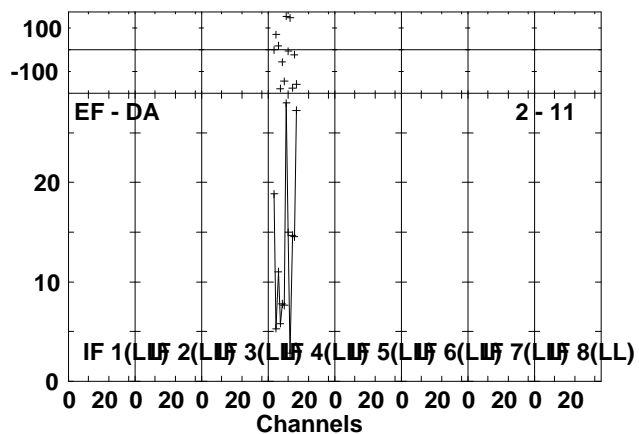
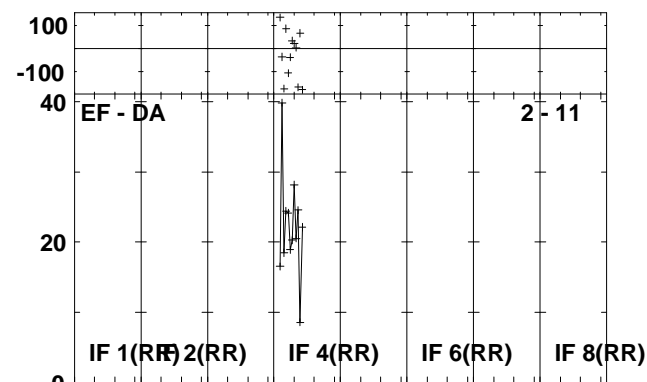
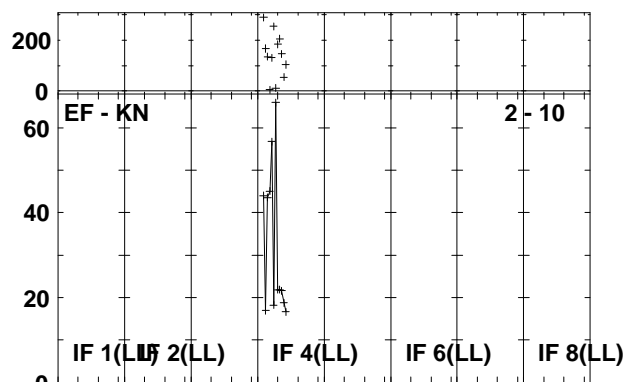
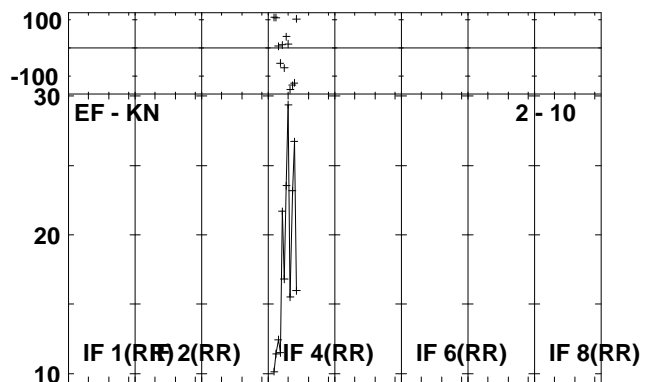
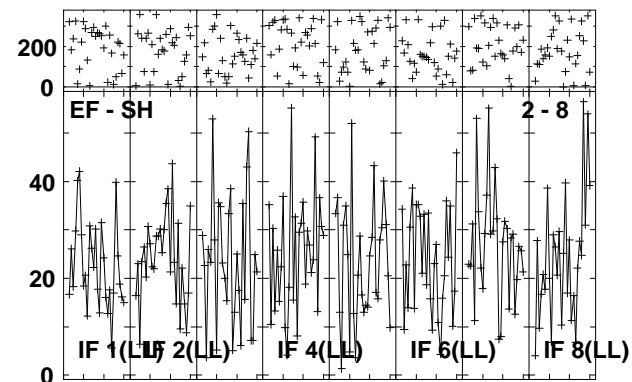
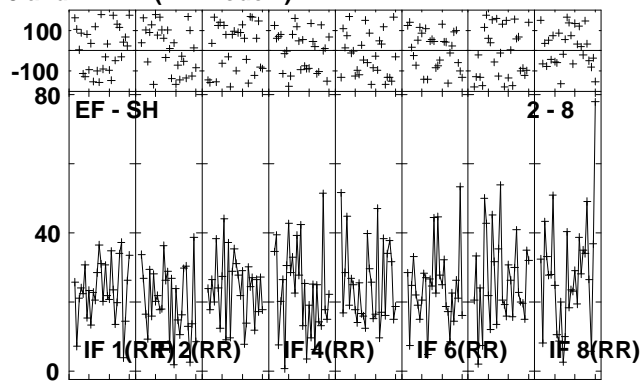
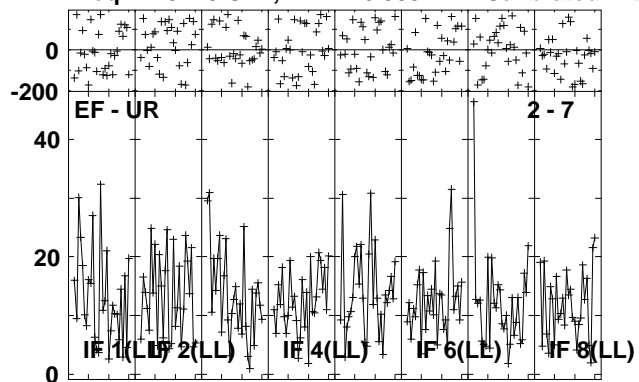

Lower frame: Milli Ampl Jy Top frame: Phas deg  
Vector averaged cross-power spectrum Several baselines displayed  
Timerange: 00/23:36:31 to 00/23:39:59

Plot file version 59 created 24-AUG-2010 08:17:14

J1941-05 EP064M.UVDATA.1

Freq = 4.9270 GHz, Bw = 16.000 MH Calibrated with CL # 3 and BP # 1 (BP mode 1)

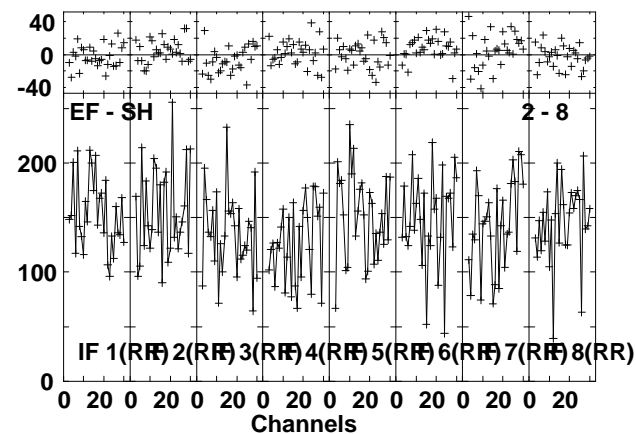
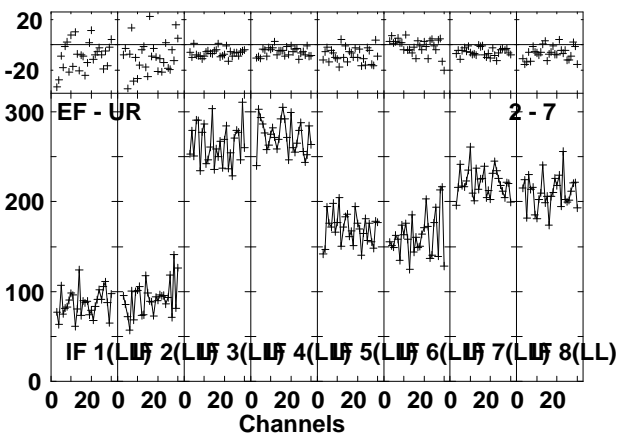
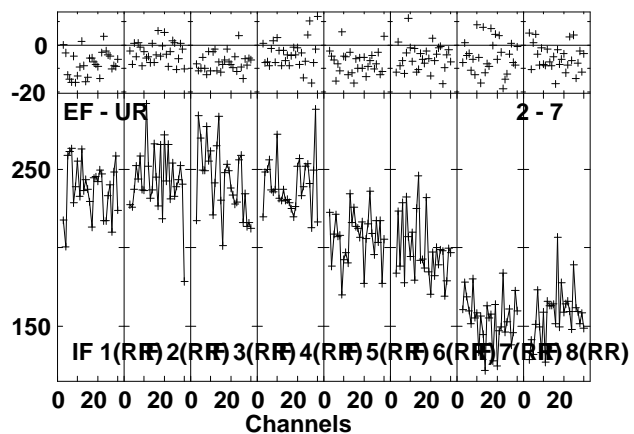
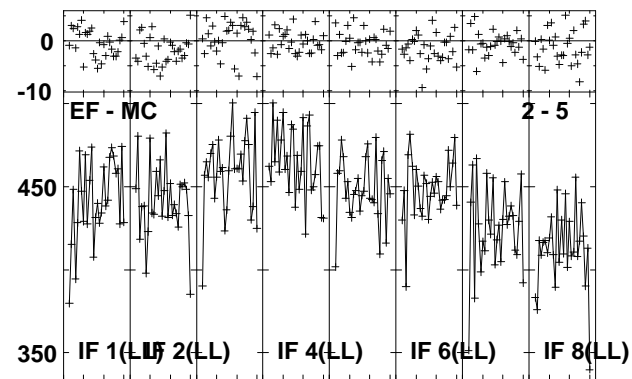
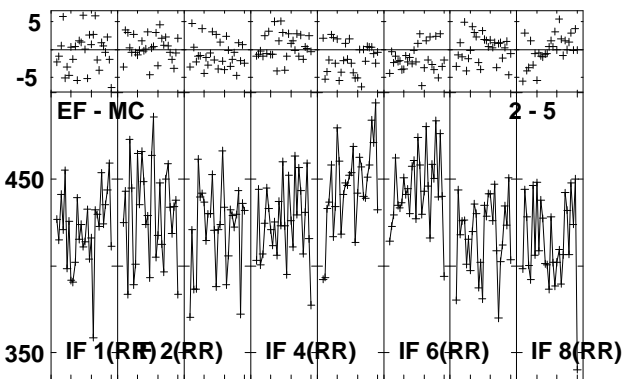
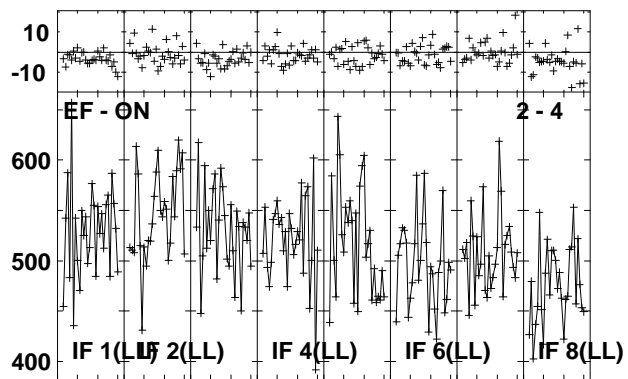
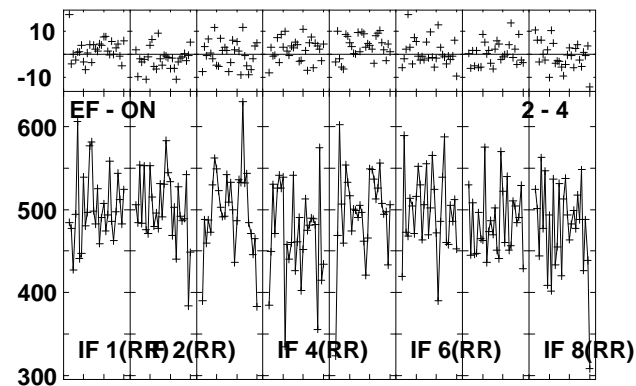
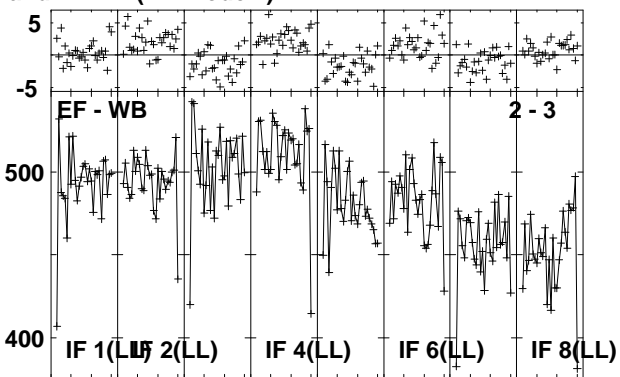
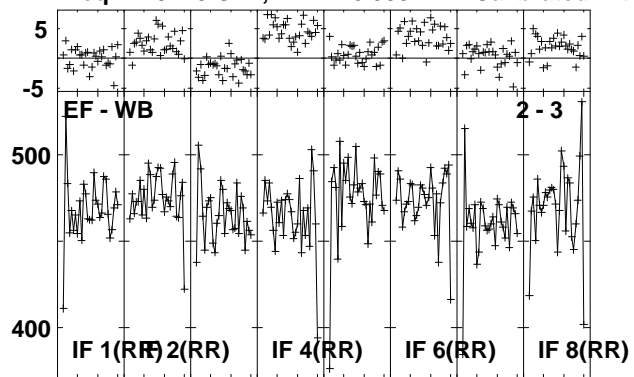

Lower frame: Milli Ampl Jy Top frame: Phas deg  
Vector averaged cross-power spectrum Several baselines displayed  
Timerange: 00/23:40:01 to 00/23:41:27

Plot file version 60 created 24-AUG-2010 08:17:15

J1941-05 EP064M.UVDATA.1

Freq = 4.9270 GHz, Bw = 16.000 MH Calibrated with CL # 3 and BP # 1 (BP mode 1)

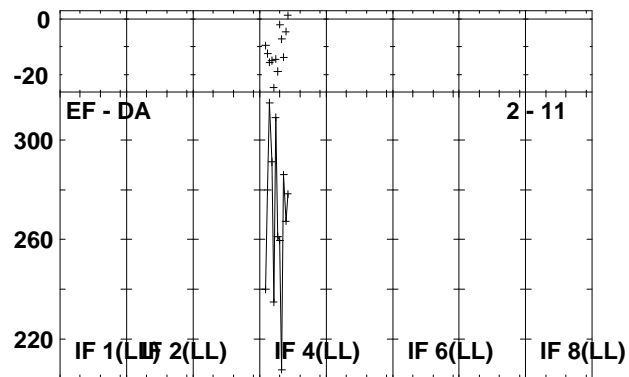
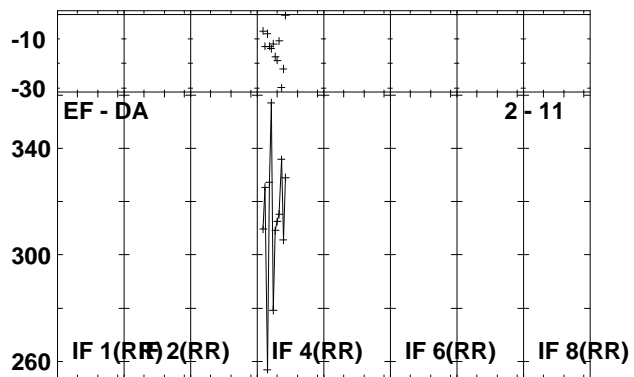
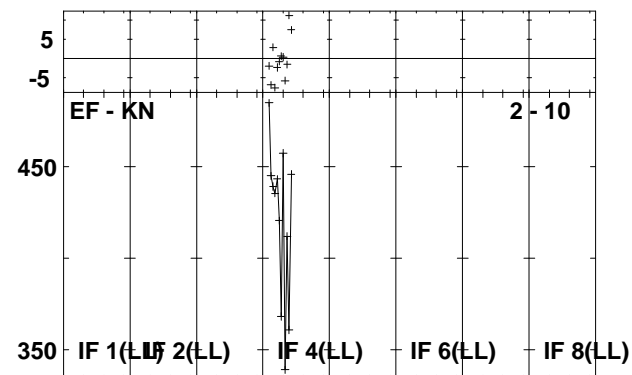
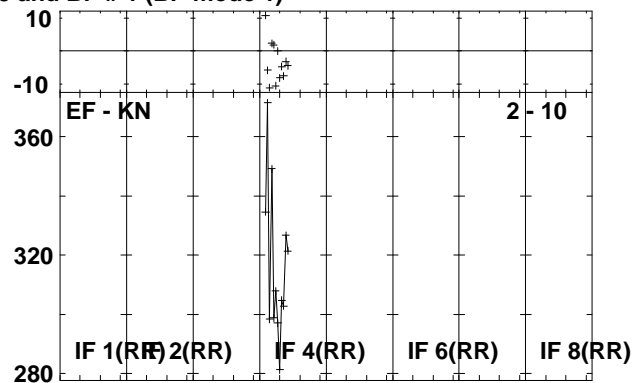
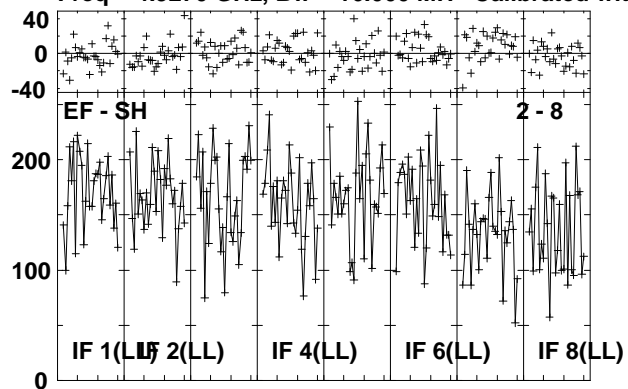

Lower frame: Milli Ampl Jy Top frame: Phas deg  
Vector averaged cross-power spectrum Several baselines displayed  
Timerange: 00/23:40:01 to 00/23:41:27

Plot file version 61 created 24-AUG-2010 08:17:16

IRAS1929 EP064M.UVDATA.1

Freq = 4.9270 GHz, Bw = 16.000 MH Calibrated with CL # 3 and BP # 1 (BP mode 1)

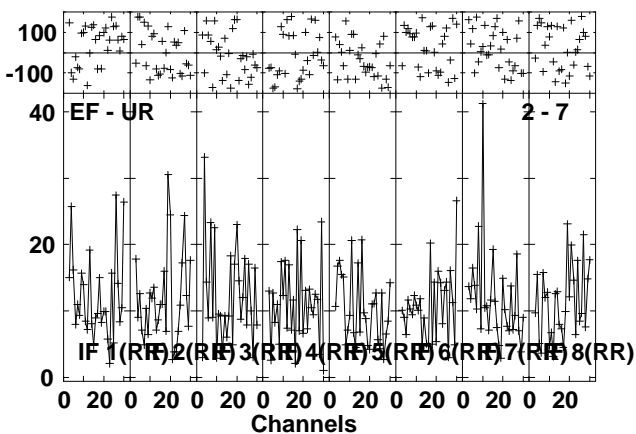
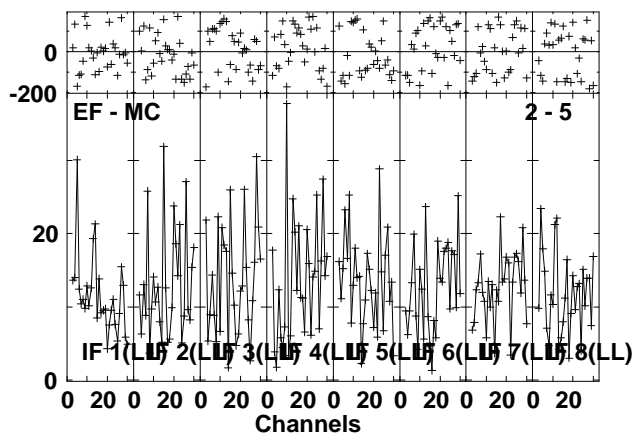
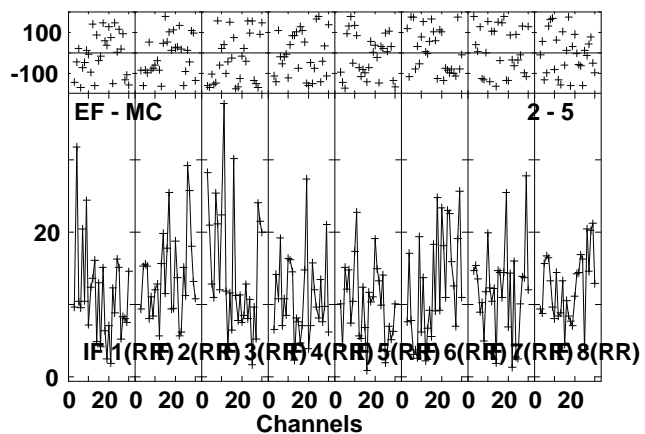
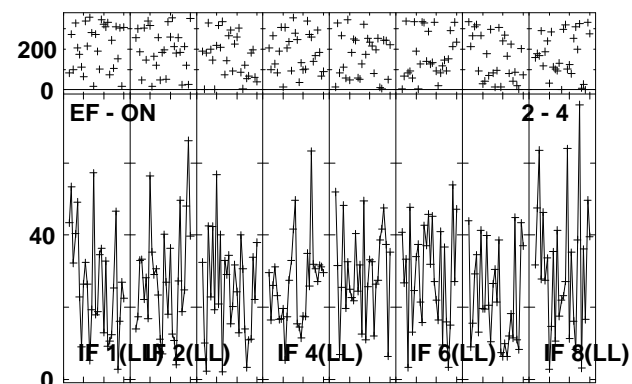
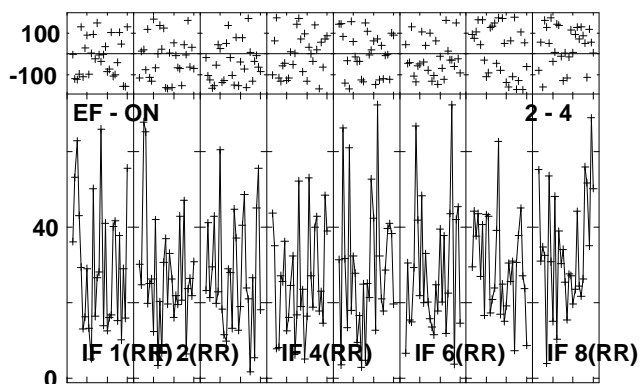
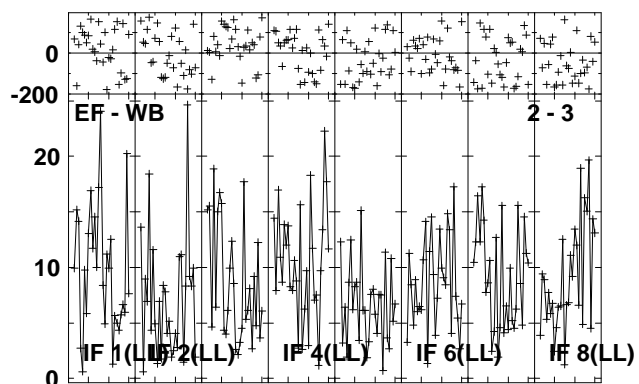
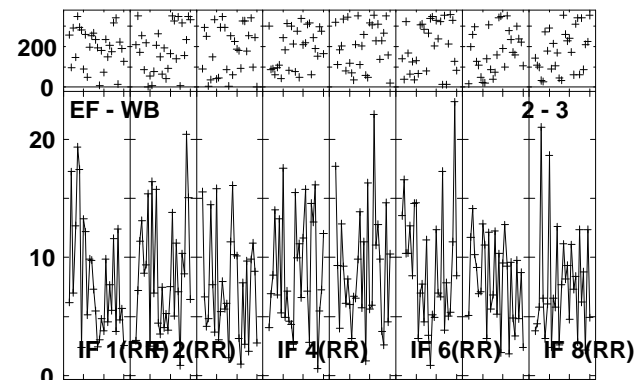
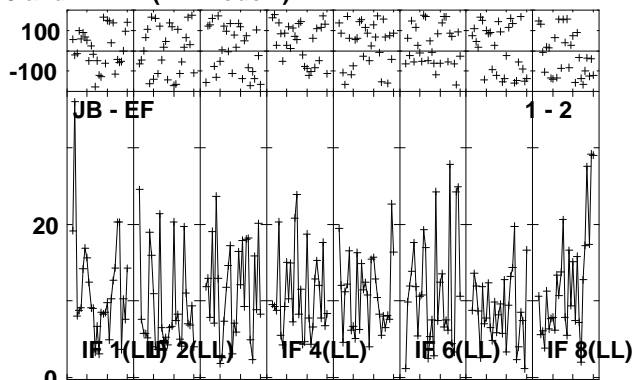
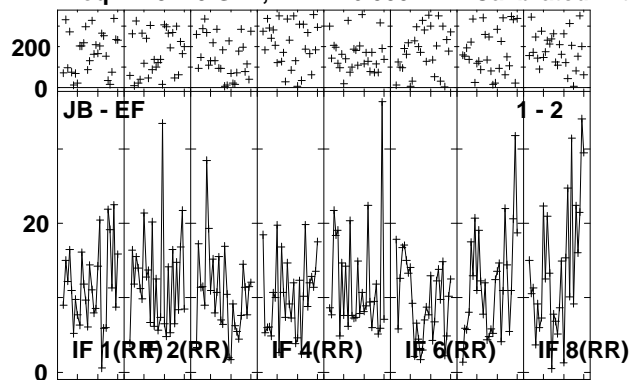

Lower frame: Milli Ampl Jy Top frame: Phas deg  
Vector averaged cross-power spectrum Several baselines displayed  
Timerange: 00/23:41:31 to 00/23:44:59

Plot file version 62 created 24-AUG-2010 08:17:20

IRAS1929 EP064M.UVDATA.1

Freq = 4.9270 GHz, Bw = 16.000 MH Calibrated with CL # 3 and BP # 1 (BP mode 1)

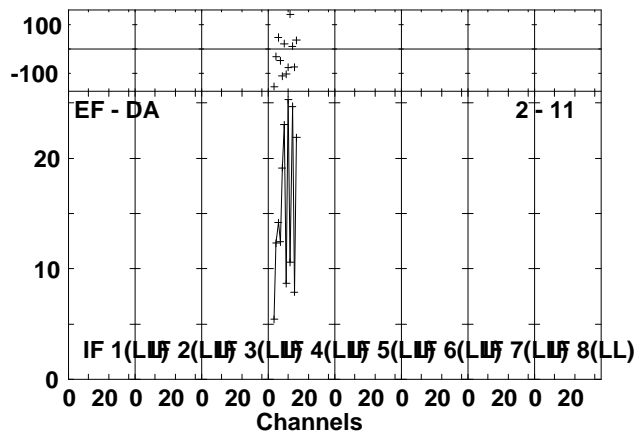
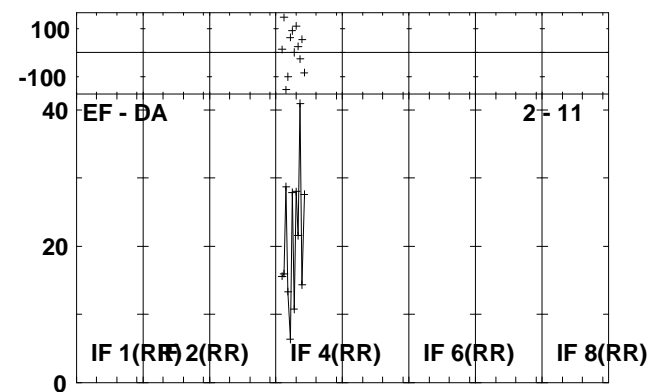
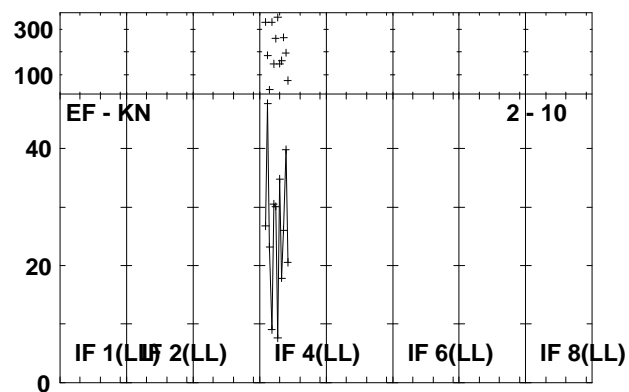
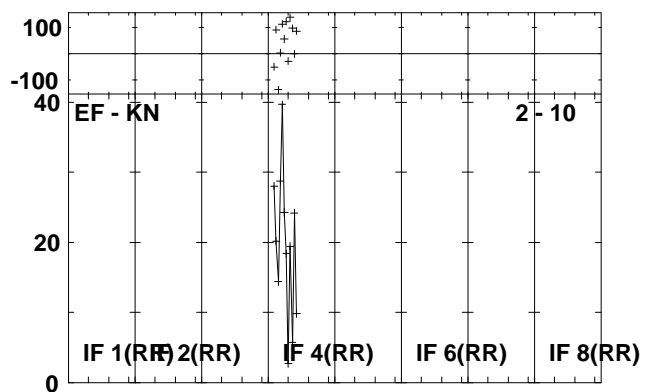
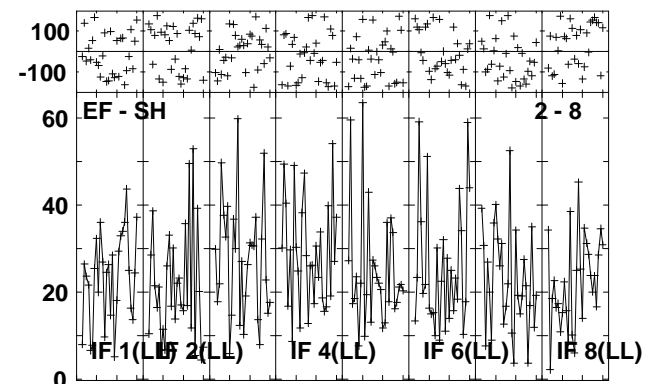
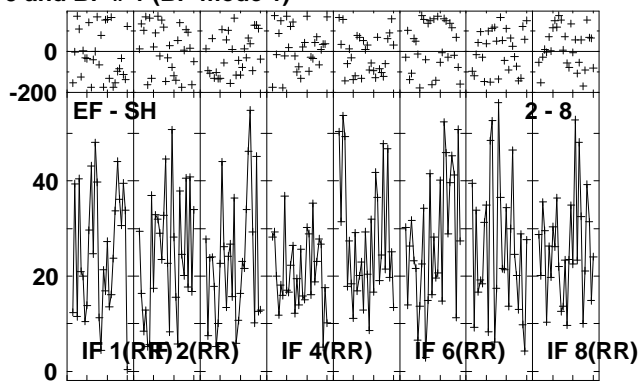
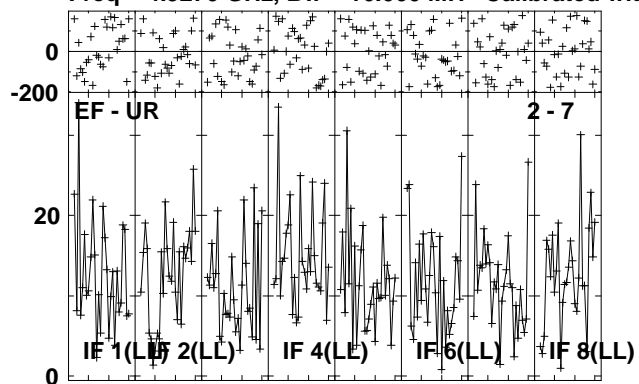

Lower frame: Milli Ampl Jy Top frame: Phas deg  
Vector averaged cross-power spectrum Several baselines displayed  
Timerange: 00/23:41:31 to 00/23:44:59

Plot file version 63 created 24-AUG-2010 08:17:23

J1941-05 EP064M.UVDATA.1

Freq = 4.9270 GHz, Bw = 16.000 MH Calibrated with CL # 3 and BP # 1 (BP mode 1)

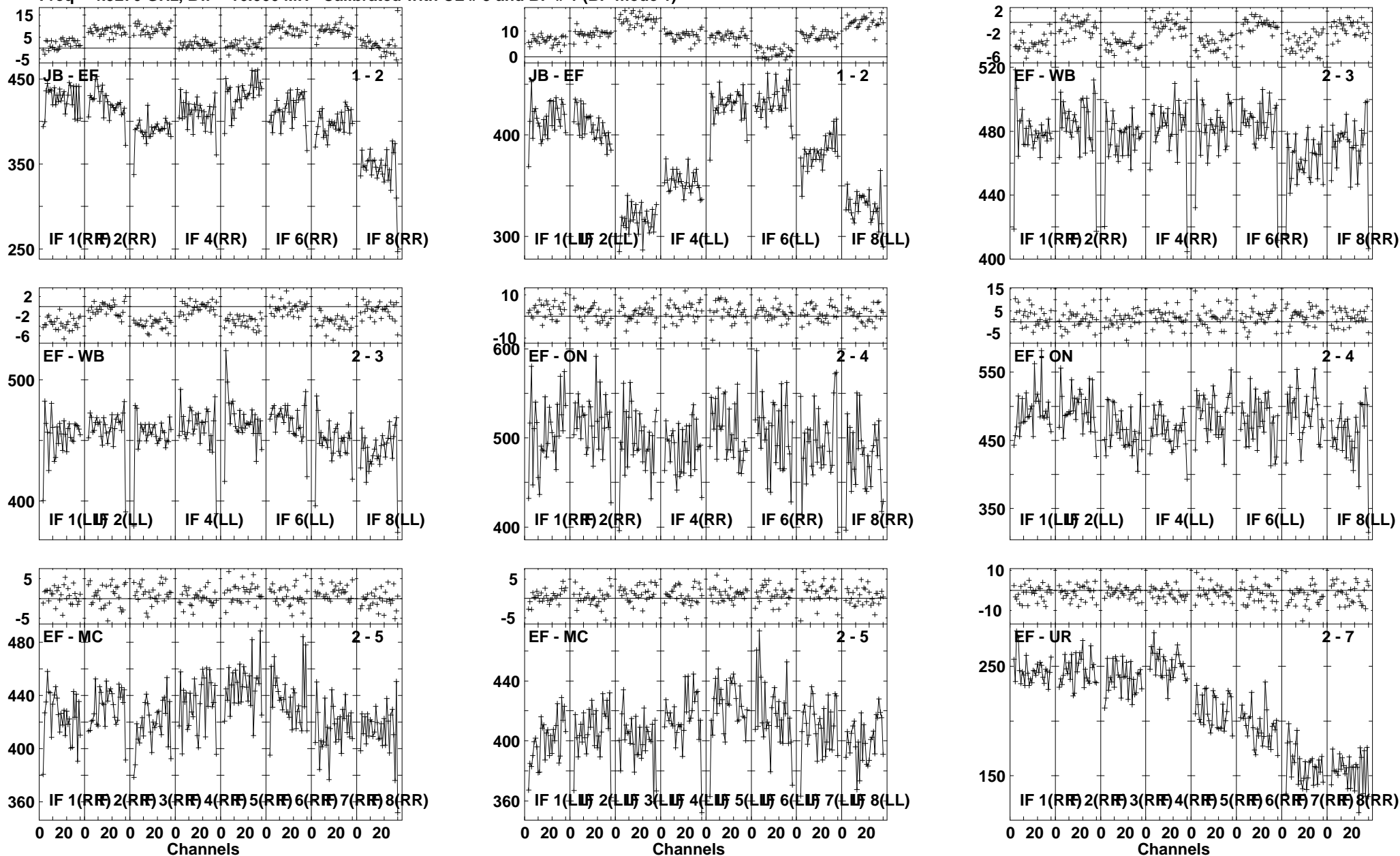

Lower frame: Milli Ampl Jy Top frame: Phas deg  
Vector averaged cross-power spectrum Several baselines displayed  
Timerange: 00/23:46:01 to 00/23:47:29

Plot file version 64 created 24-AUG-2010 08:17:24

J1941-05 EP064M.UVDATA.1

Freq = 4.9270 GHz, Bw = 16.000 MH Calibrated with CL # 3 and BP # 1 (BP mode 1)

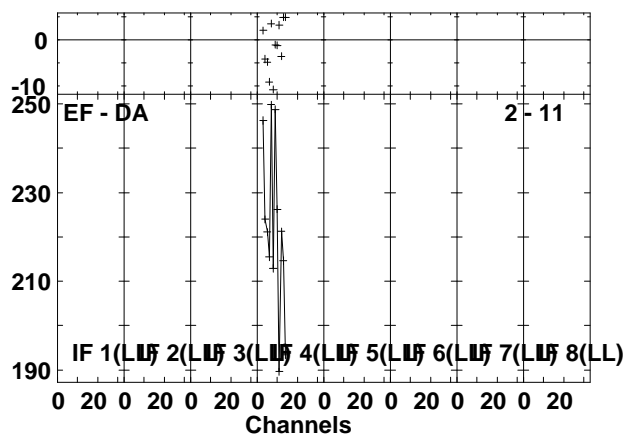
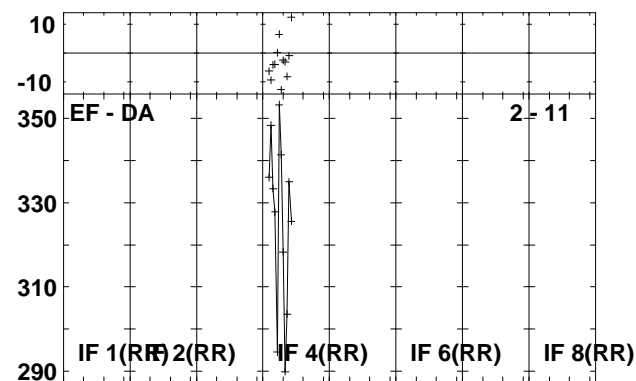
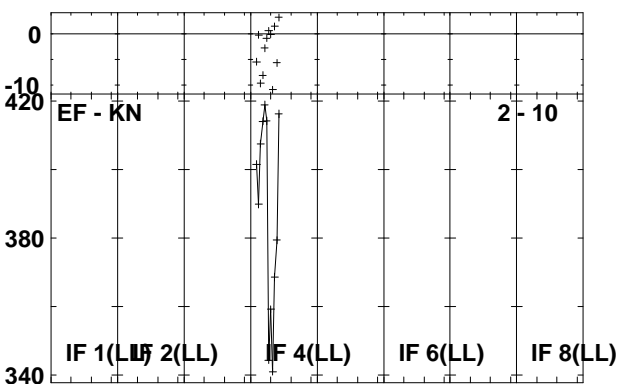
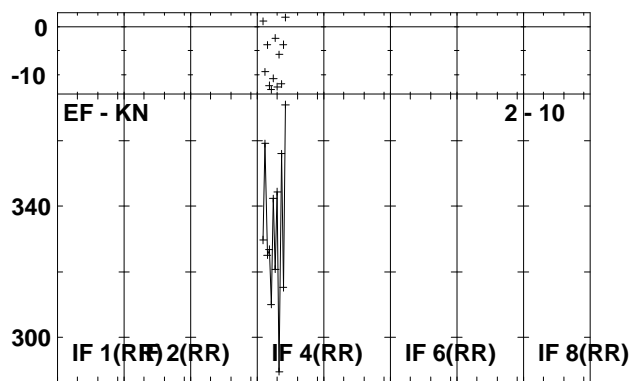
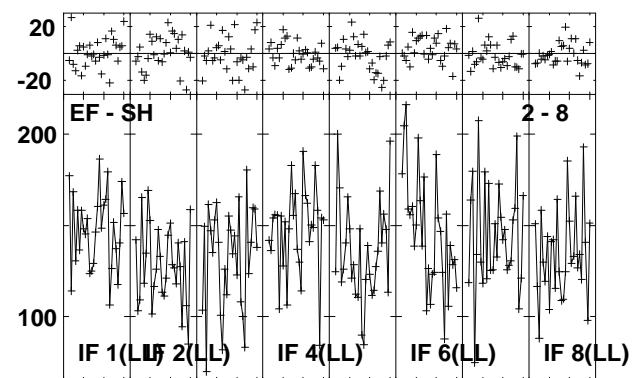
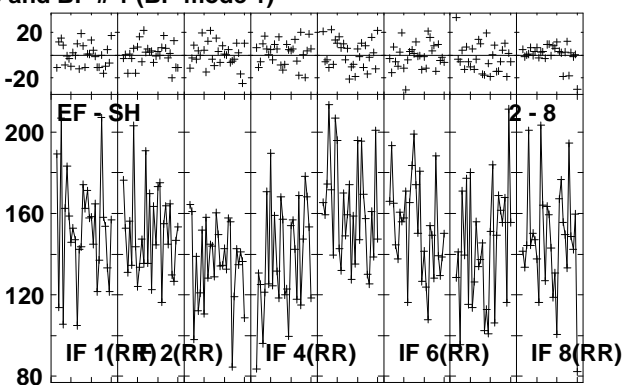
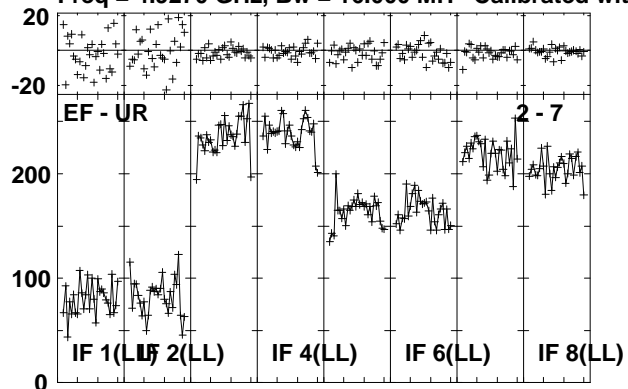

Lower frame: Milli Ampl Jy Top frame: Phas deg  
Vector averaged cross-power spectrum Several baselines displayed  
Timerange: 00/23:46:01 to 00/23:47:29



Plot file version 65 created 24-AUG-2010 08:17:26

IRAS1929 EP064M.UVDATA.1

Freq = 4.9270 GHz, Bw = 16.000 MH Calibrated with CL # 3 and BP # 1 (BP mode 1)

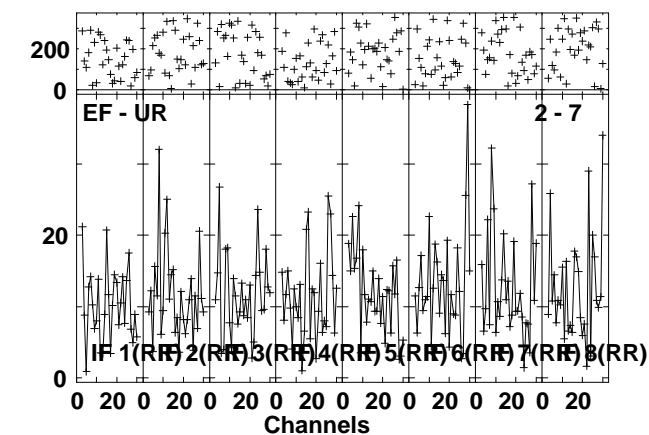
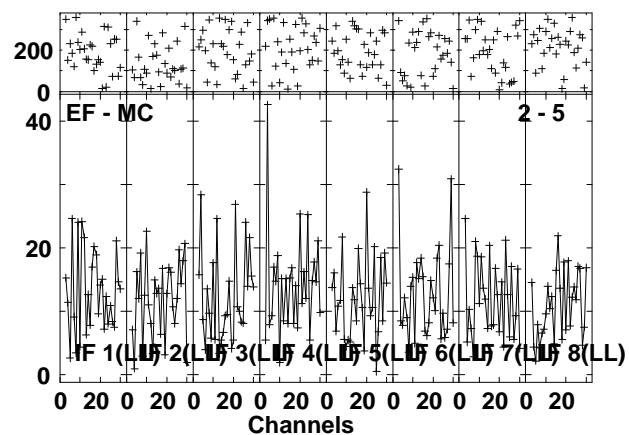
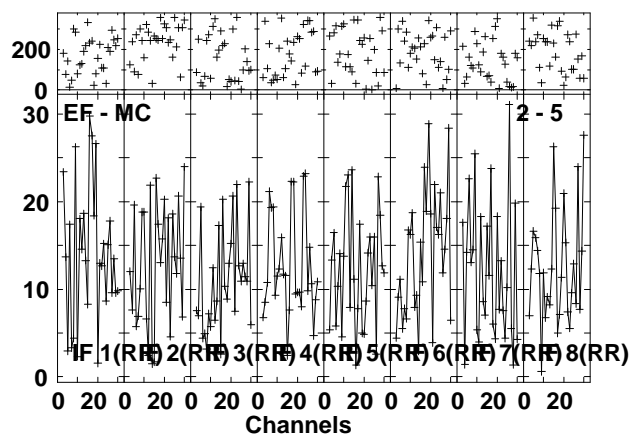
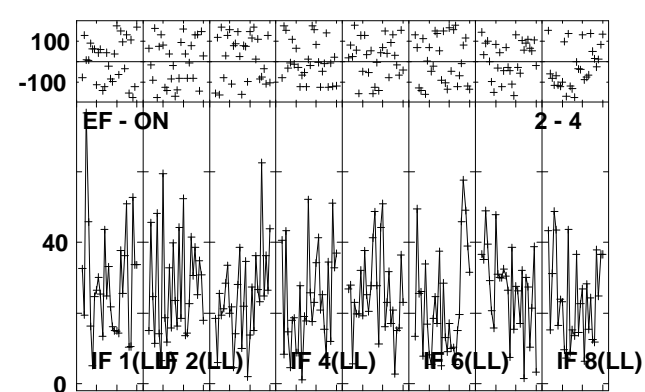
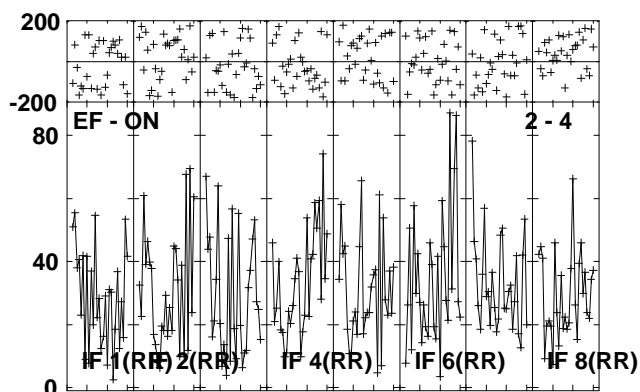
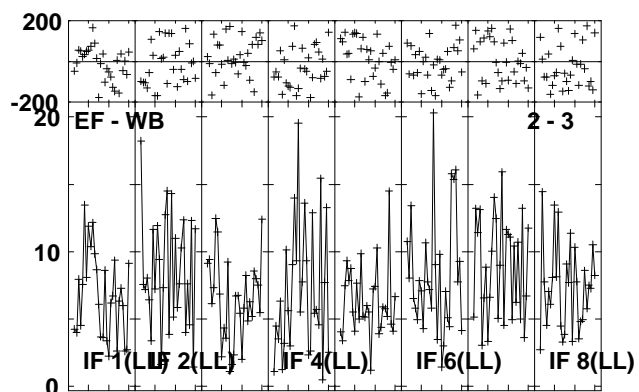
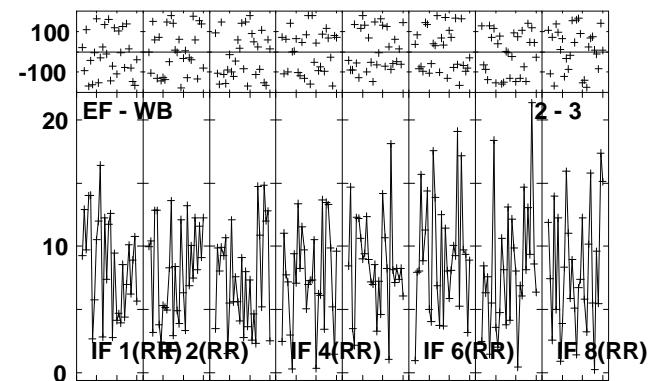
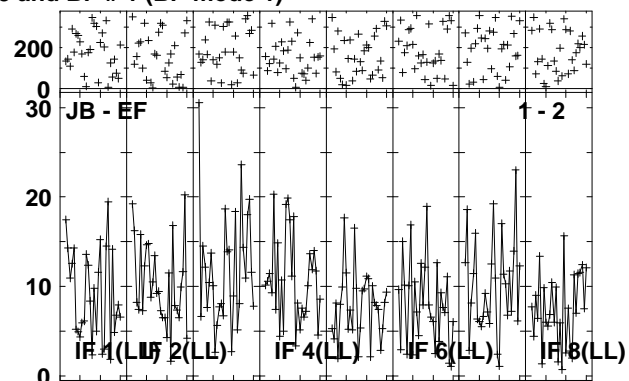
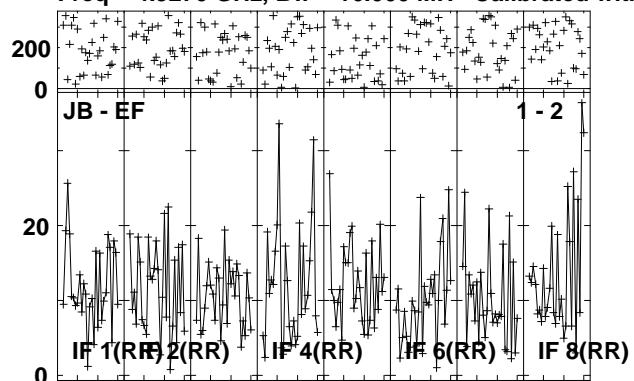

Lower frame: Milli Ampl Jy Top frame: Phas deg  
Vector averaged cross-power spectrum Several baselines displayed  
Timerange: 00/23:47:31 to 00/23:50:59

Plot file version 66 created 24-AUG-2010 08:17:30

IRAS1929 EP064M.UVDATA.1

Freq = 4.9270 GHz, Bw = 16.000 MH Calibrated with CL # 3 and BP # 1 (BP mode 1)

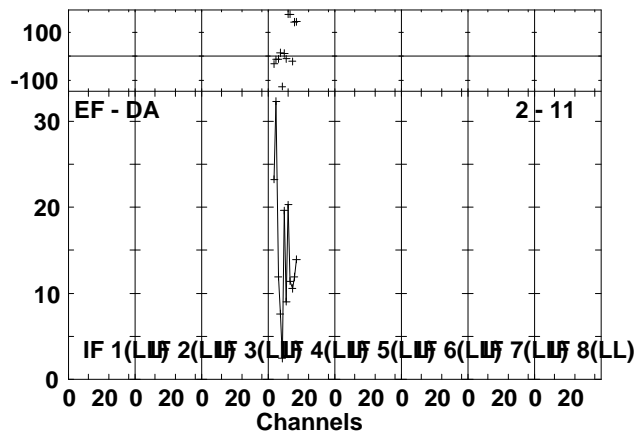
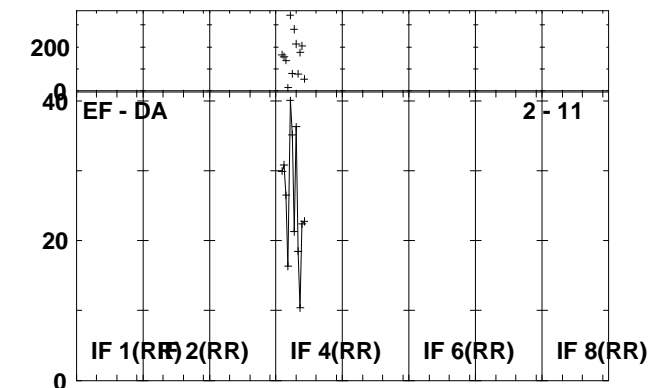
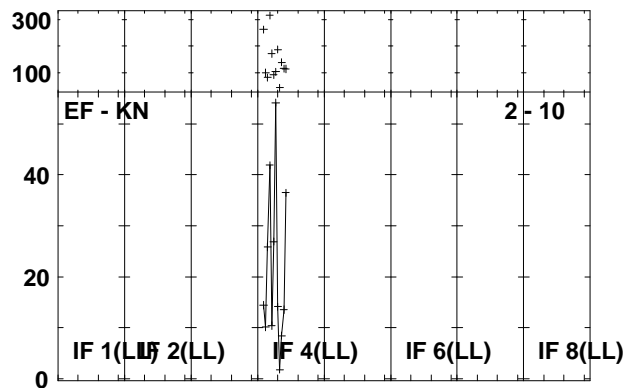
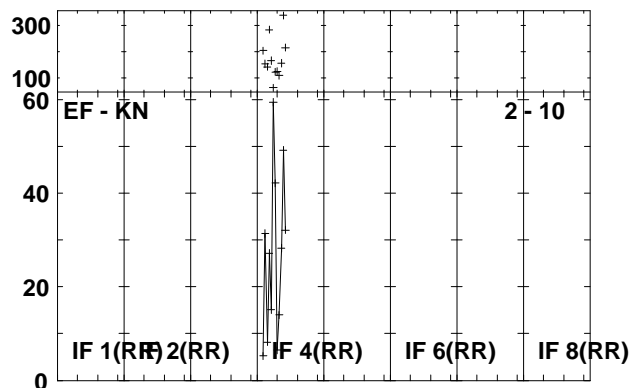
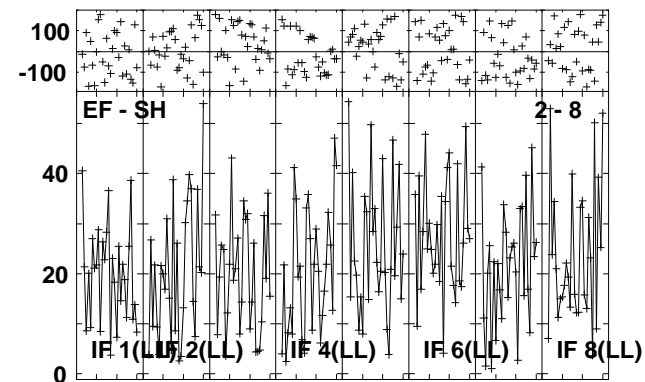
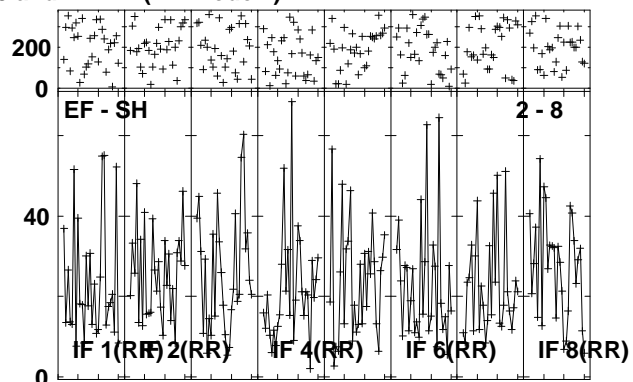
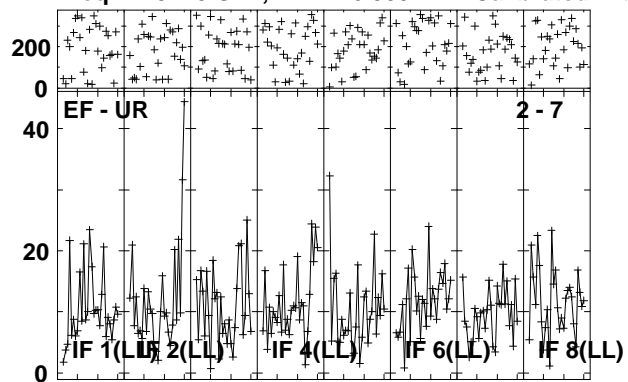

Lower frame: Milli Ampl Jy Top frame: Phas deg  
Vector averaged cross-power spectrum Several baselines displayed  
Timerange: 00/23:47:31 to 00/23:50:59

Plot file version 67 created 24-AUG-2010 08:17:33

J1941-05 EP064M.UVDATA.1

Freq = 4.9270 GHz, Bw = 16.000 MH Calibrated with CL # 3 and BP # 1 (BP mode 1)

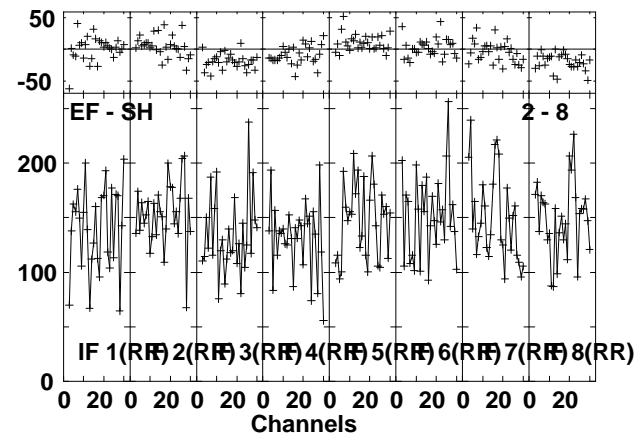
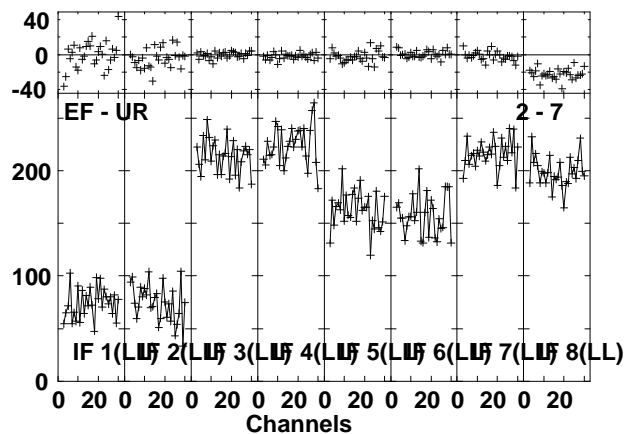
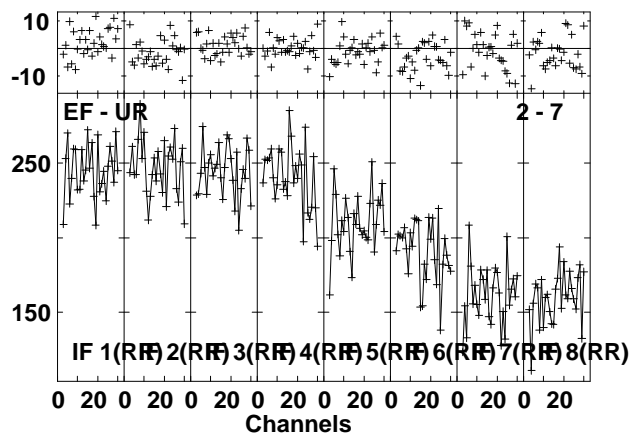
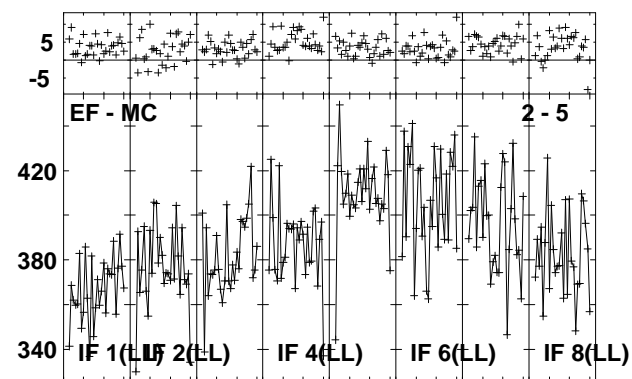
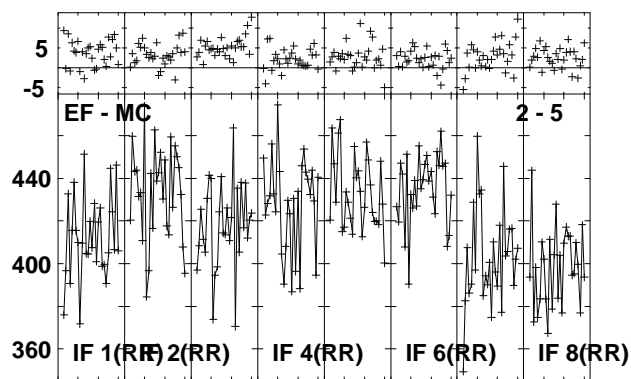
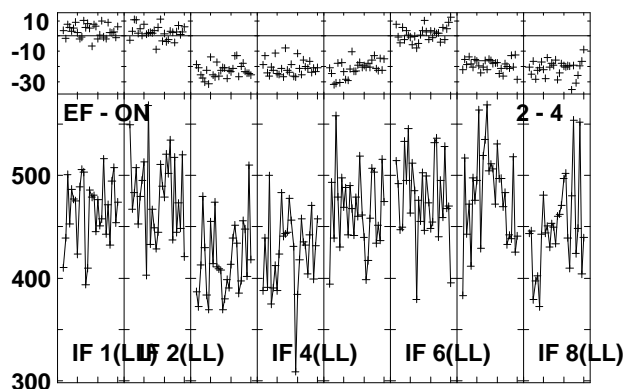
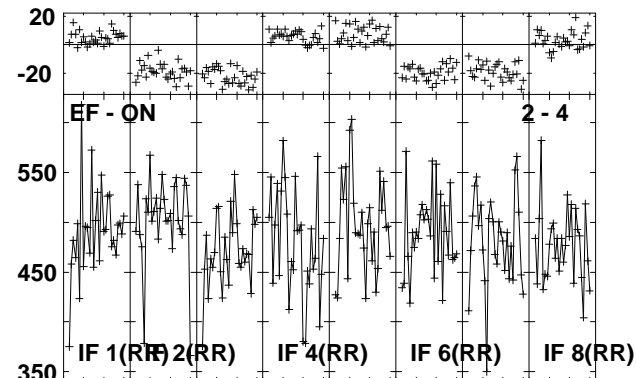
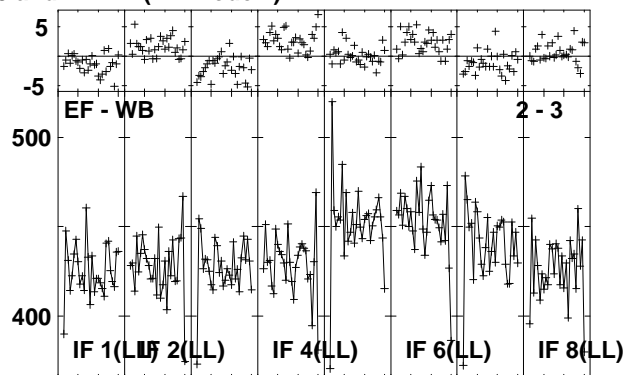
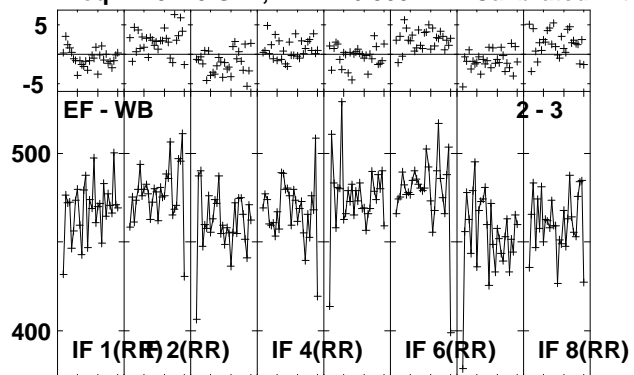

Lower frame: Milli Ampl Jy Top frame: Phas deg  
Vector averaged cross-power spectrum Several baselines displayed  
Timerange: 00/23:51:01 to 00/23:52:29

Plot file version 68 created 24-AUG-2010 08:17:35

J1941-05 EP064M.UVDATA.1

Freq = 4.9270 GHz, Bw = 16.000 MH Calibrated with CL # 3 and BP # 1 (BP mode 1)

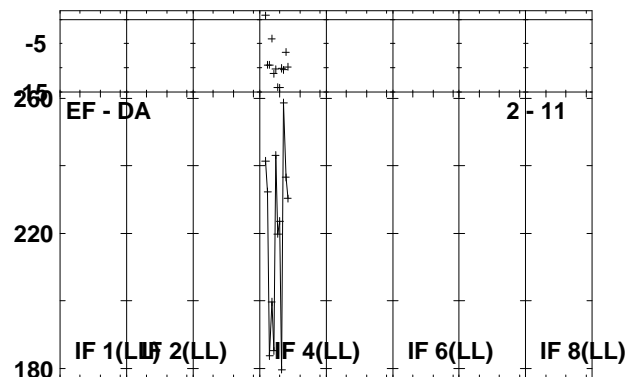
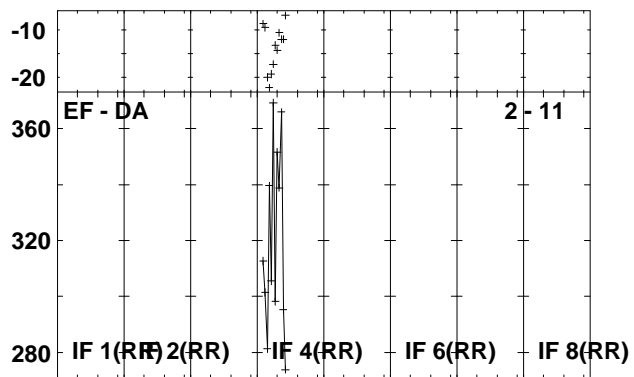
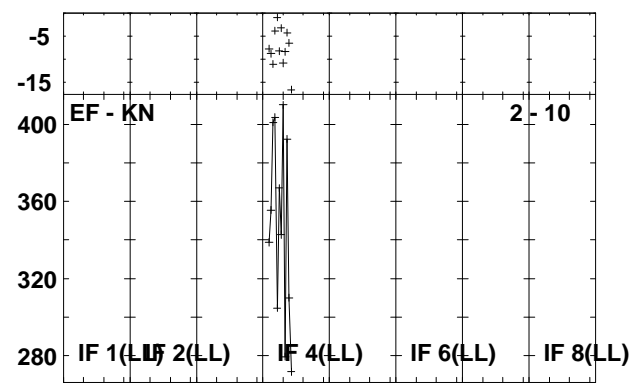
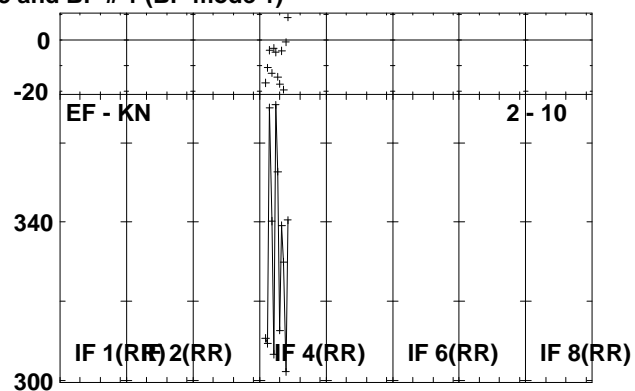
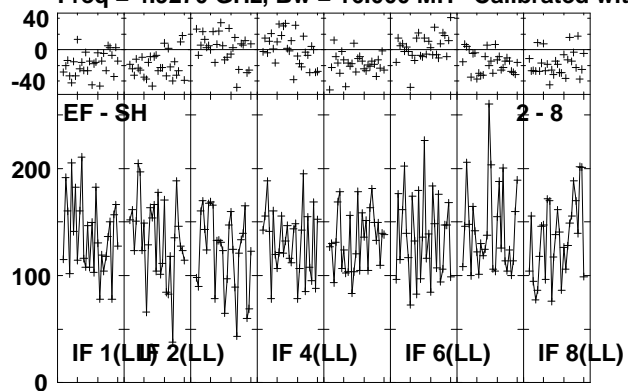

Lower frame: Milli Ampl Jy Top frame: Phas deg  
Vector averaged cross-power spectrum Several baselines displayed  
Timerange: 00/23:51:01 to 00/23:52:29

Plot file version 69 created 24-AUG-2010 08:17:36

IRAS1929 EP064M.UVDATA.1

Freq = 4.9270 GHz, Bw = 16.000 MH Calibrated with CL # 3 and BP # 1 (BP mode 1)

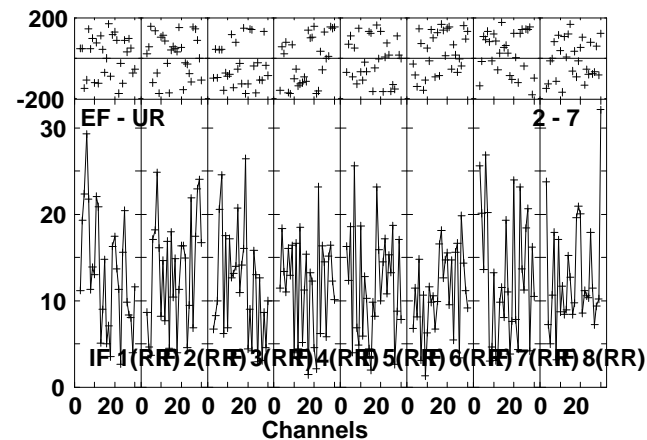
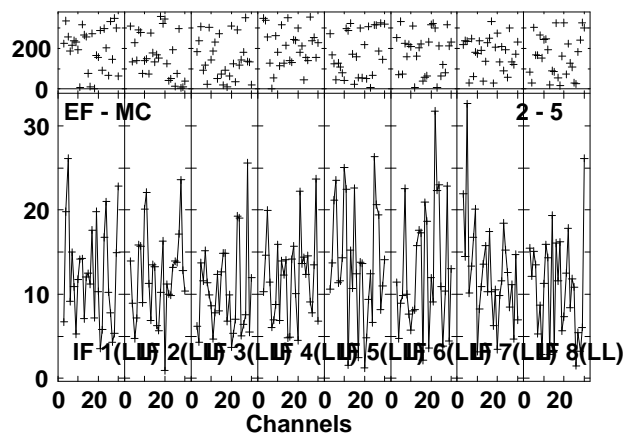
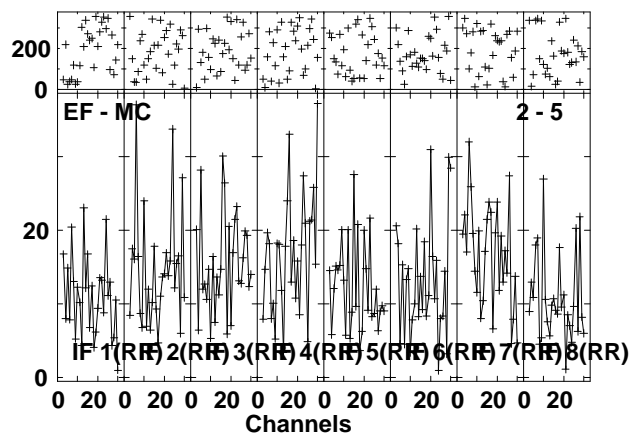
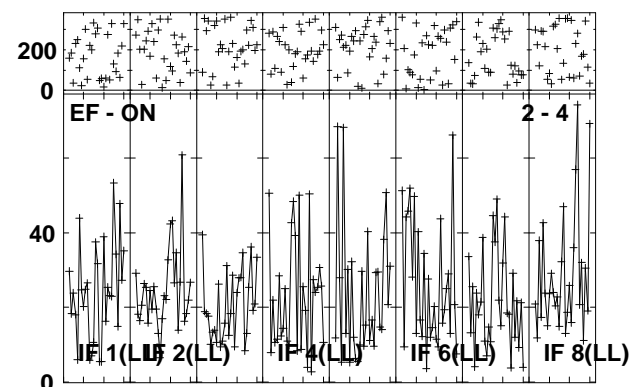
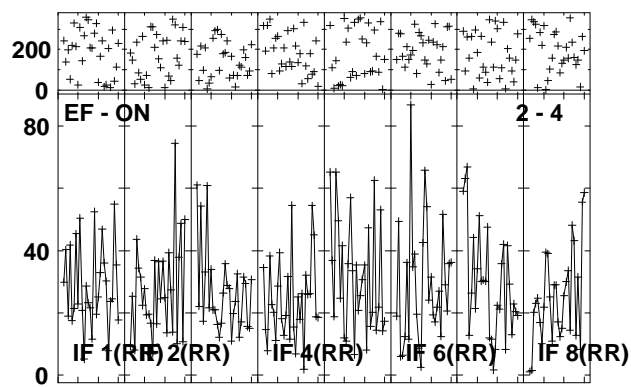
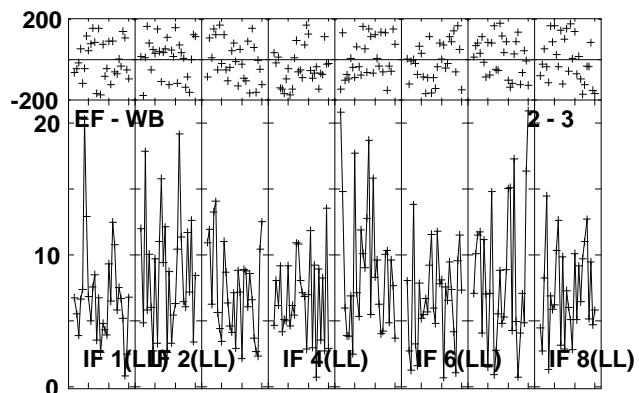
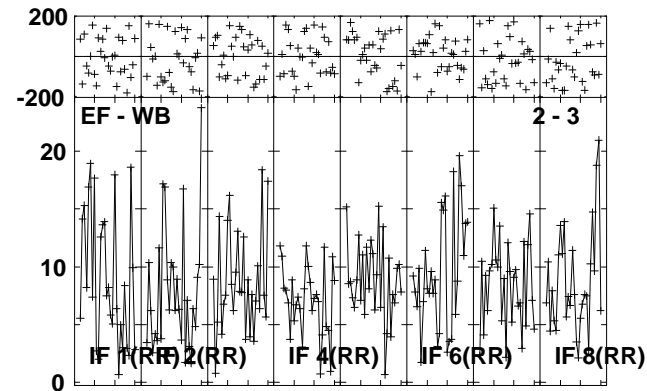
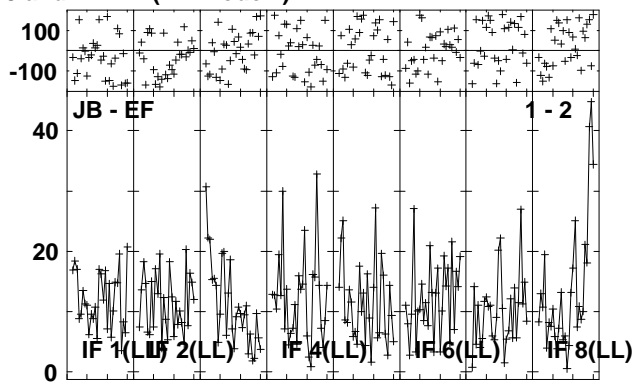
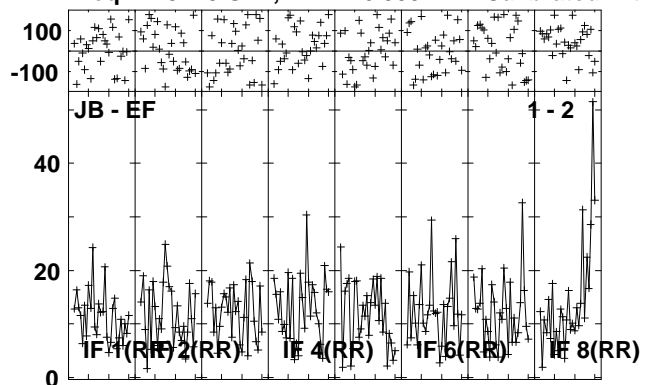

Lower frame: Milli Ampl Jy Top frame: Phas deg  
Vector averaged cross-power spectrum Several baselines displayed  
Timerange: 00/23:52:31 to 00/23:55:59

Plot file version 70 created 24-AUG-2010 08:17:40

IRAS1929 EP064M.UVDATA.1

Freq = 4.9270 GHz, Bw = 16.000 MH Calibrated with CL # 3 and BP # 1 (BP mode 1)

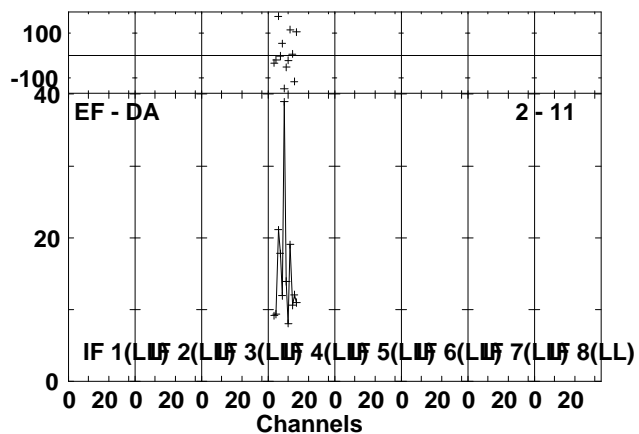
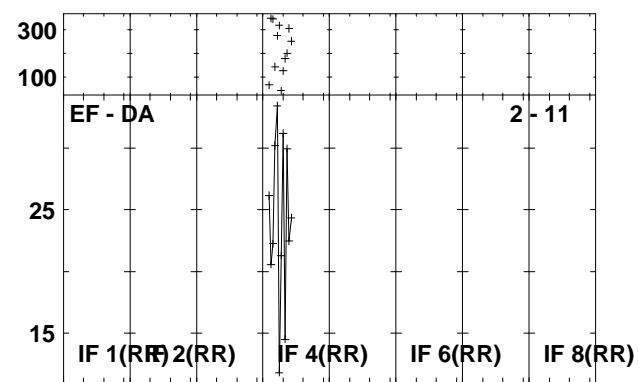
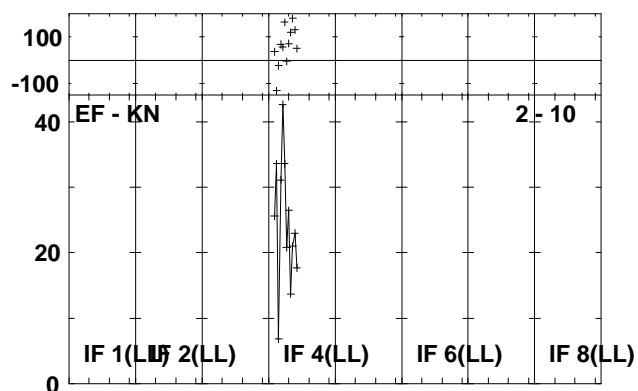
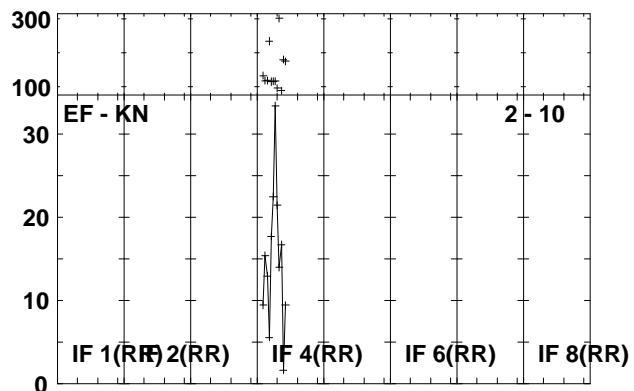
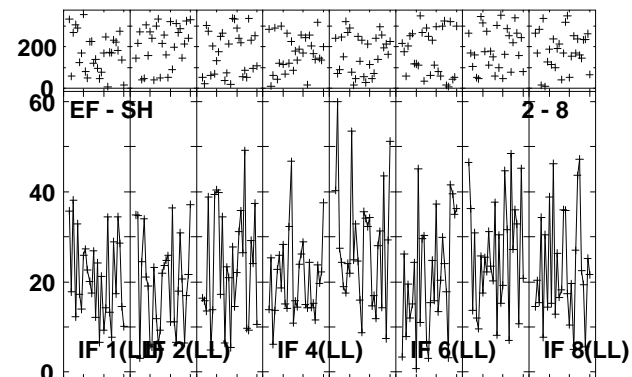
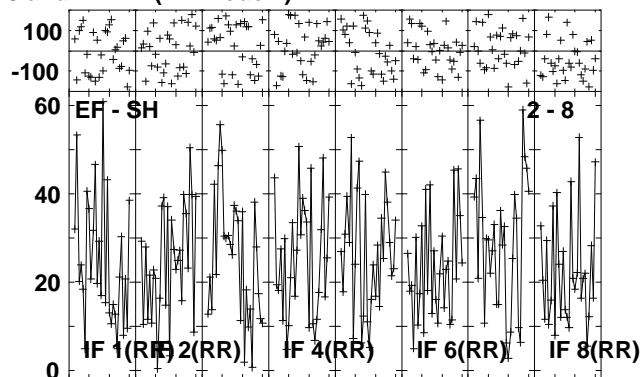
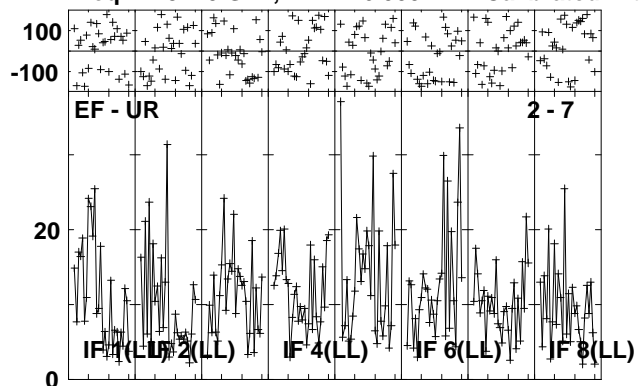

Lower frame: Milli Ampl Jy Top frame: Phas deg  
Vector averaged cross-power spectrum Several baselines displayed  
Timerange: 00/23:52:31 to 00/23:55:59

Plot file version 71 created 24-AUG-2010 08:17:43

J1941-05 EP064M.UVDATA.1

Freq = 4.9270 GHz, Bw = 16.000 MH Calibrated with CL # 3 and BP # 1 (BP mode 1)

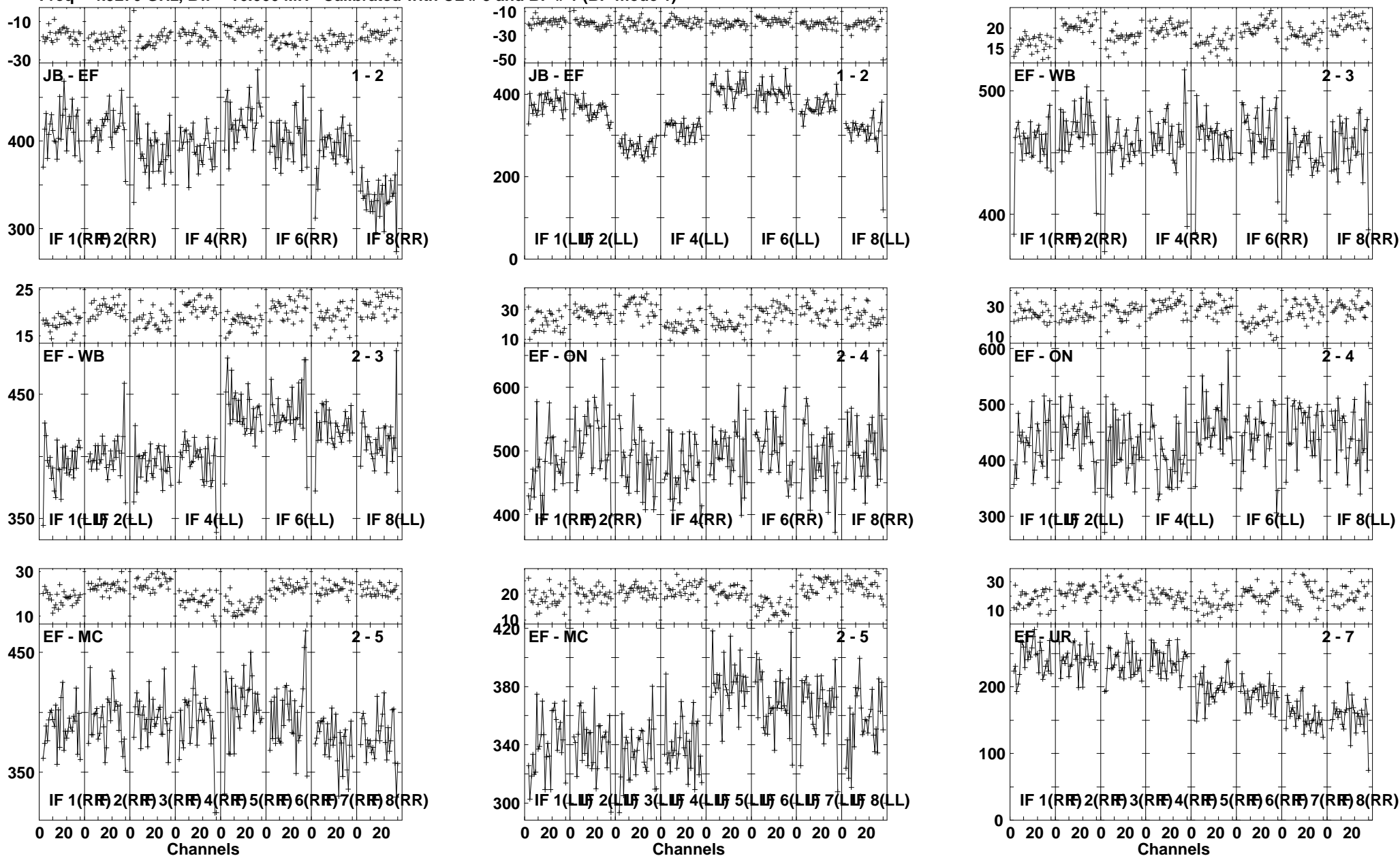

Lower frame: Milli Ampl Jy Top frame: Phas deg  
Vector averaged cross-power spectrum Several baselines displayed  
Timerange: 00/23:56:01 to 00/23:57:29

Plot file version 72 created 24-AUG-2010 08:17:44

J1941-05 EP064M.UVDATA.1

Freq = 4.9270 GHz, Bw = 16.000 MH Calibrated with CL # 3 and BP # 1 (BP mode 1)

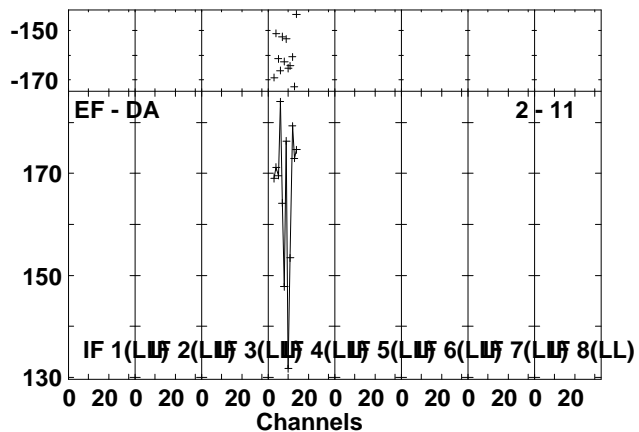
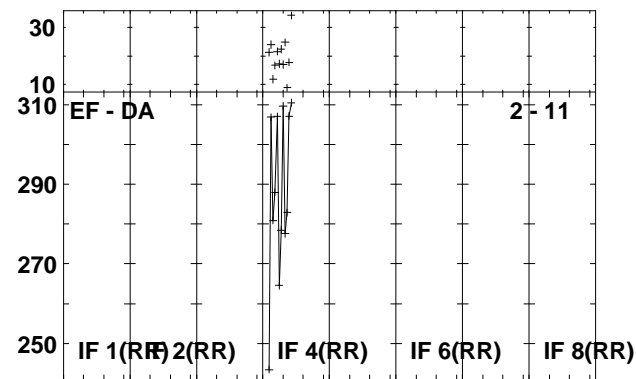
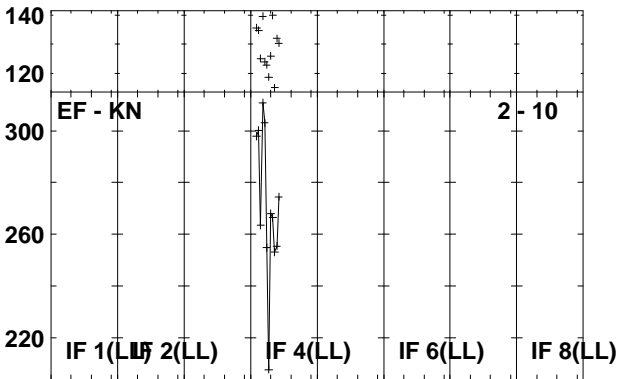
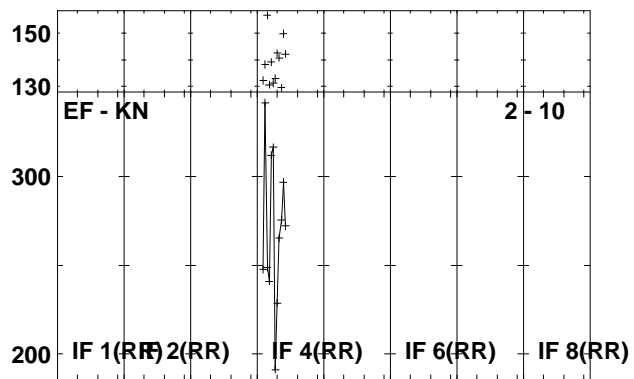
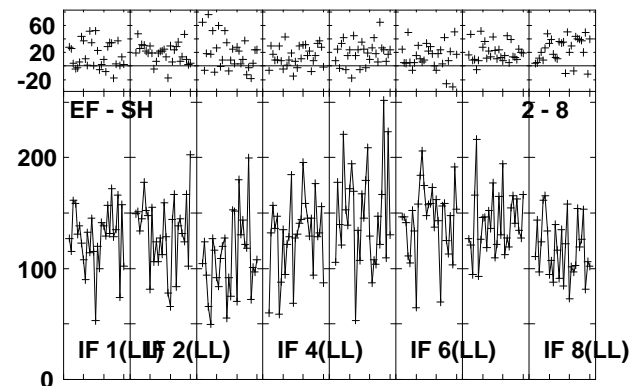
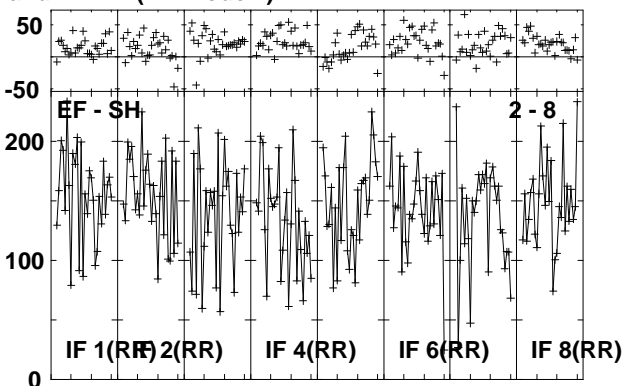
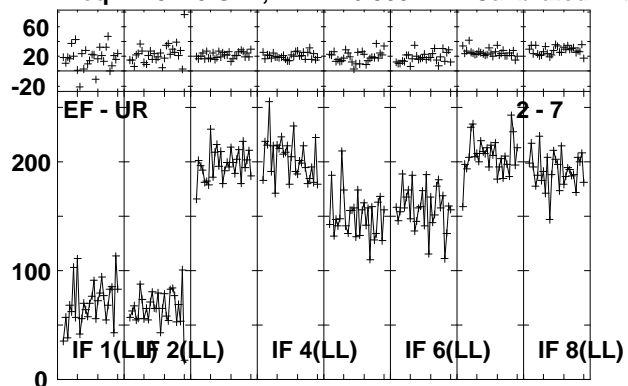

Lower frame: Milli Ampl Jy Top frame: Phas deg  
Vector averaged cross-power spectrum Several baselines displayed  
Timerange: 00/23:56:01 to 00/23:57:29



Plot file version 73 created 24-AUG-2010 08:17:46

IRAS1929 EP064M.UVDATA.1

Freq = 4.9270 GHz, Bw = 16.000 MH Calibrated with CL # 3 and BP # 1 (BP mode 1)

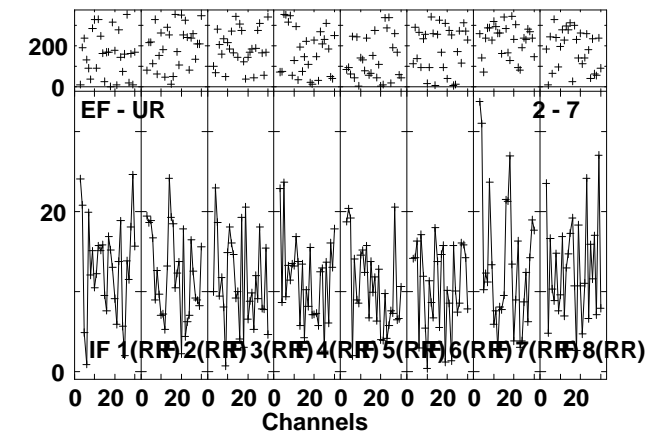
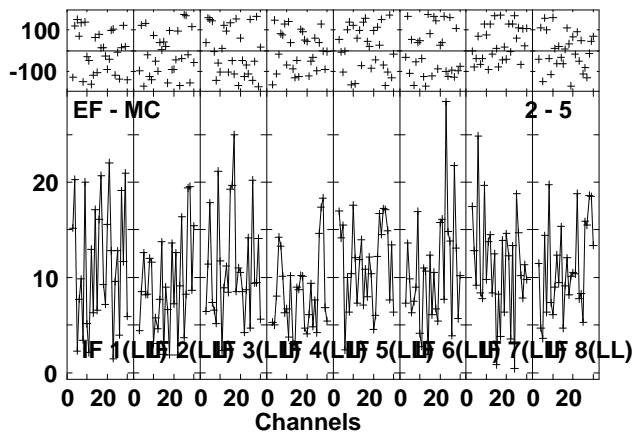
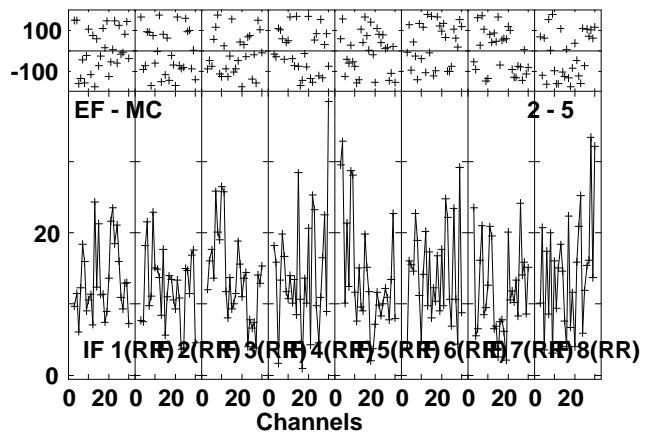
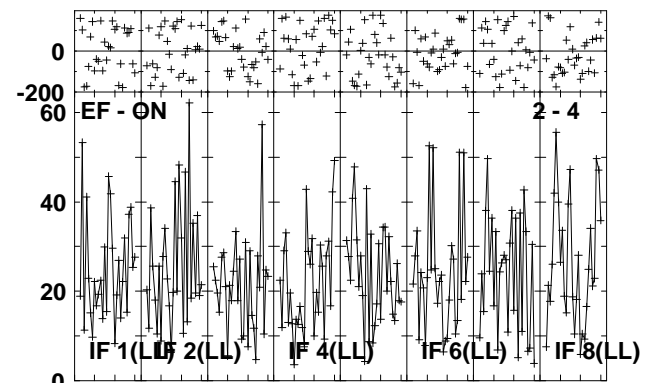
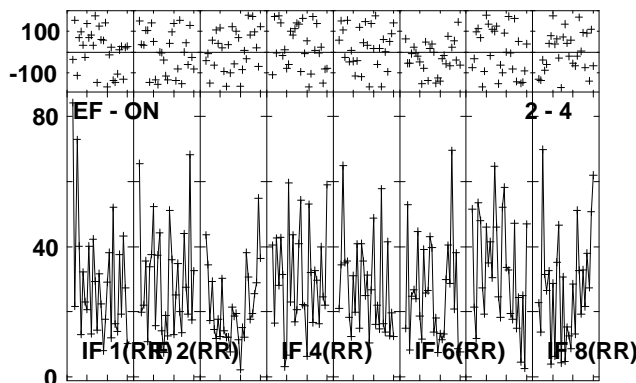
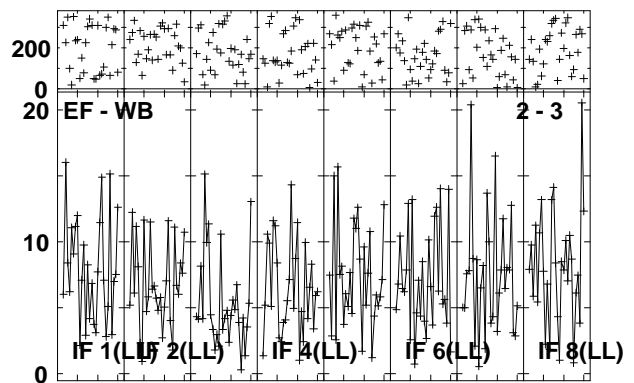
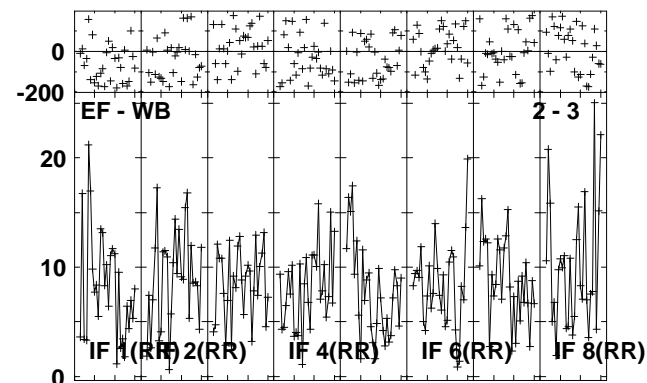
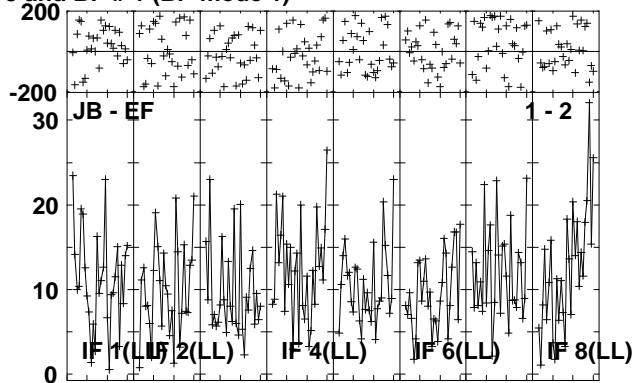
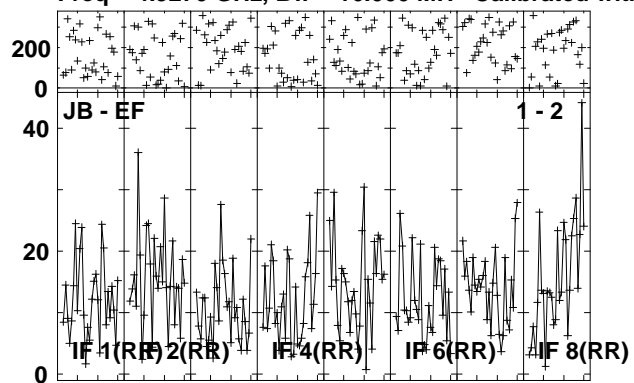

Lower frame: Milli Ampl Jy Top frame: Phas deg  
Vector averaged cross-power spectrum Several baselines displayed  
Timerange: 00/23:57:31 to 01/00:00:59

Plot file version 74 created 24-AUG-2010 08:17:50

IRAS1929 EP064M.UVDATA.1

Freq = 4.9270 GHz, Bw = 16.000 MH Calibrated with CL # 3 and BP # 1 (BP mode 1)

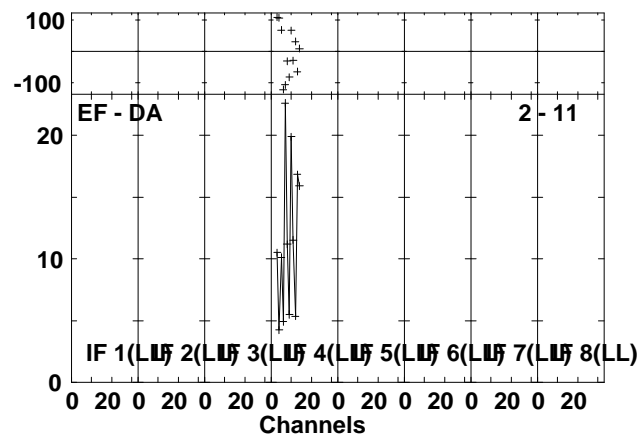
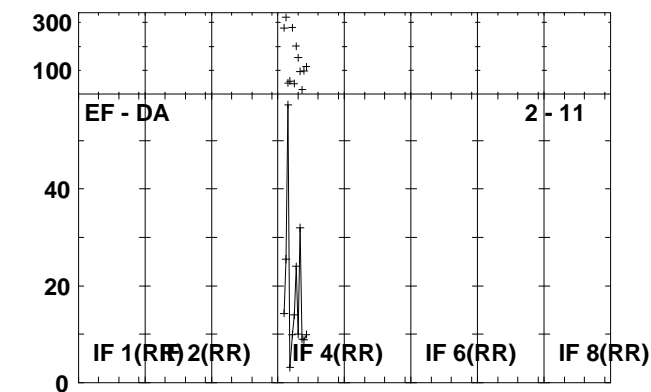
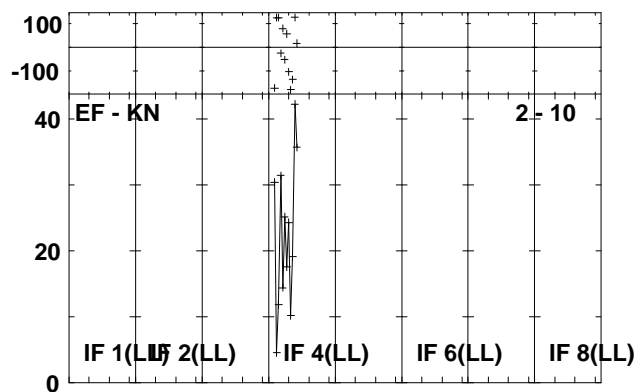
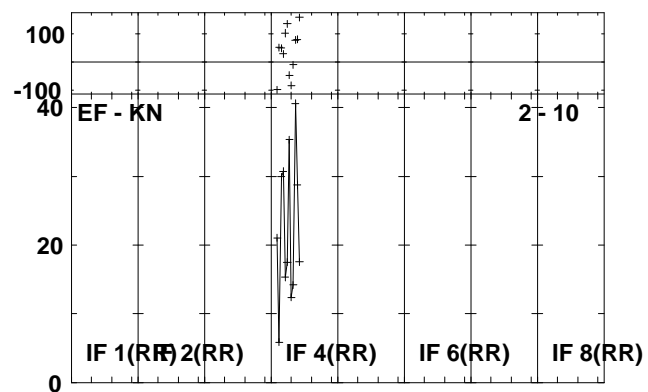
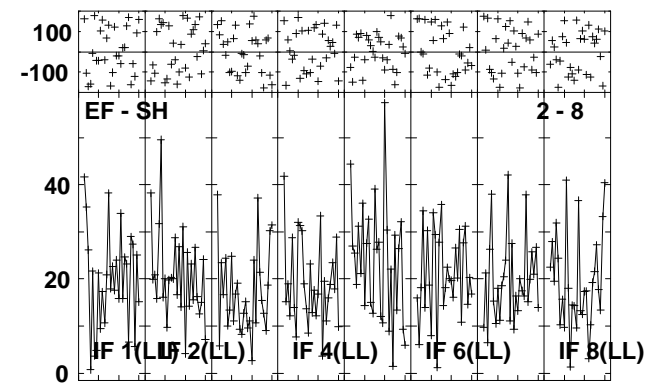
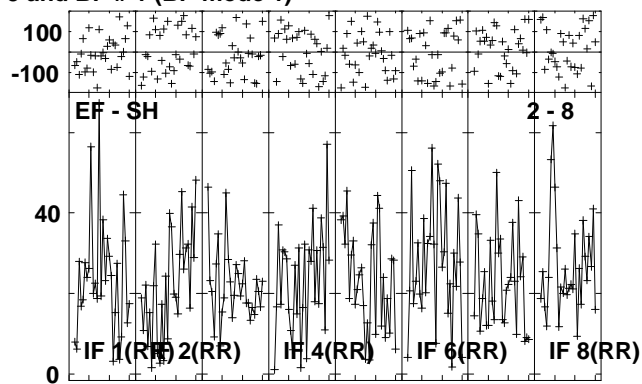
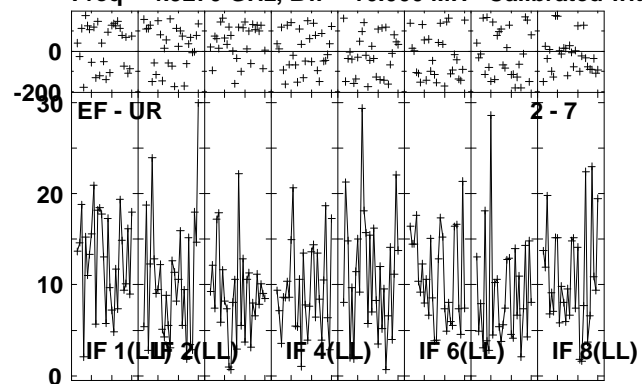

Lower frame: Milli Ampl Jy Top frame: Phas deg  
Vector averaged cross-power spectrum Several baselines displayed  
Timerange: 00:23:57:31 to 01:00:00:59

Plot file version 75 created 24-AUG-2010 08:17:53

J1941-05 EP064M.UVDATA.1

Freq = 4.9270 GHz, Bw = 16.000 MH Calibrated with CL # 3 and BP # 1 (BP mode 1)

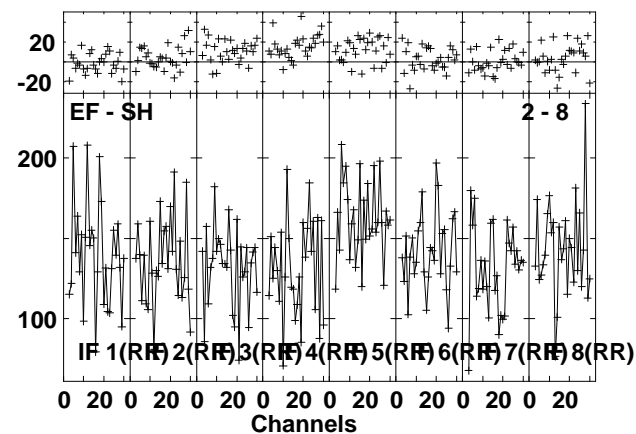
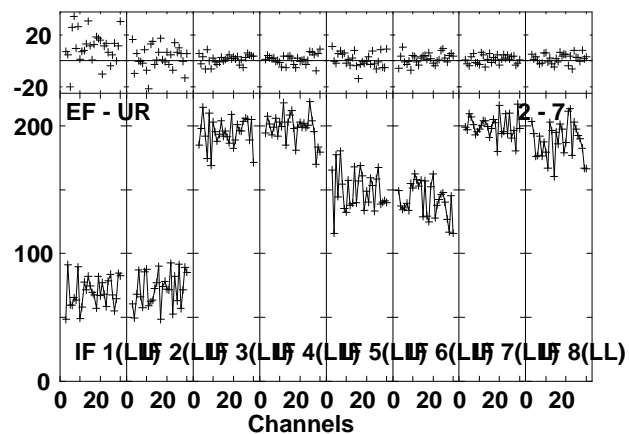
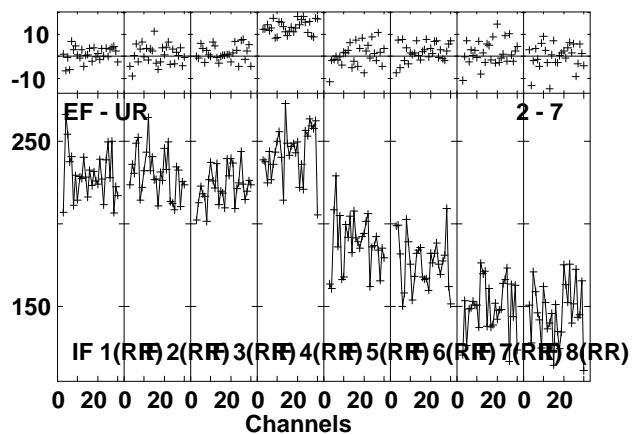
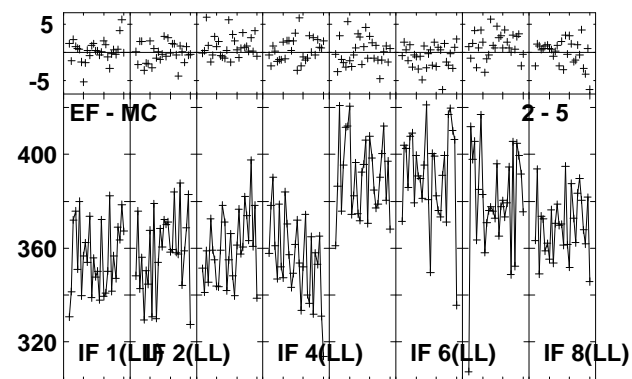
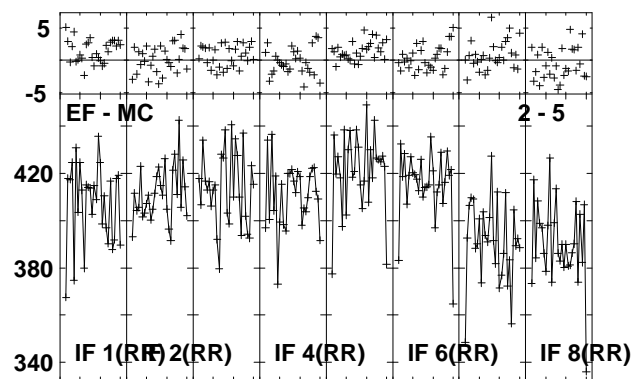
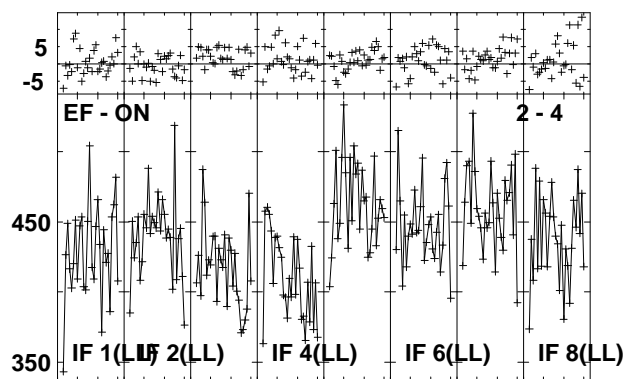
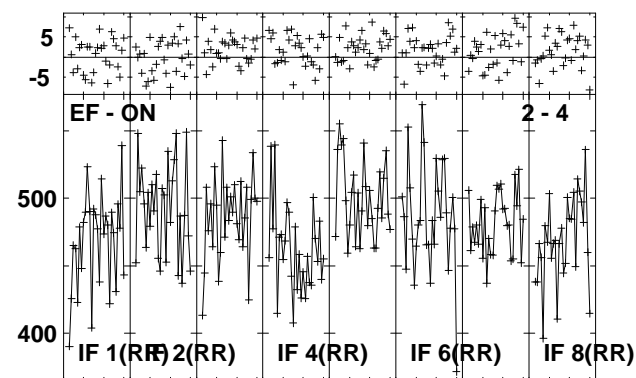
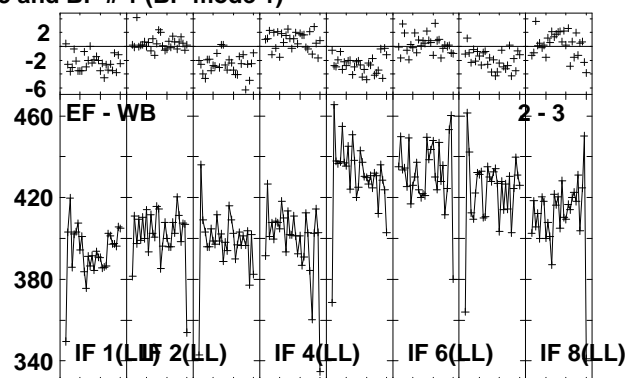
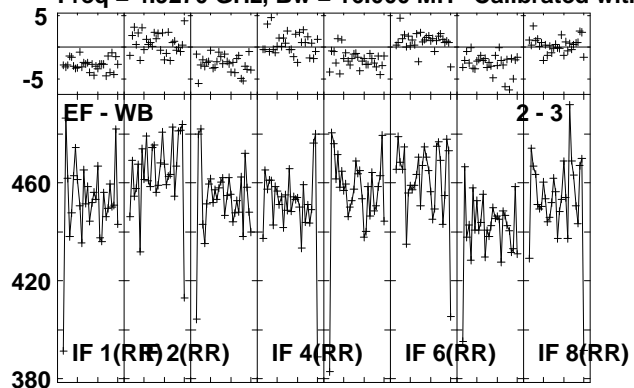

Lower frame: Milli Ampl Jy Top frame: Phas deg  
Vector averaged cross-power spectrum Several baselines displayed  
Timerange: 01/00:02:01 to 01/00:03:27

Plot file version 76 created 24-AUG-2010 08:17:55

J1941-05 EP064M.UVDATA.1

Freq = 4.9270 GHz, Bw = 16.000 MH Calibrated with CL # 3 and BP # 1 (BP mode 1)

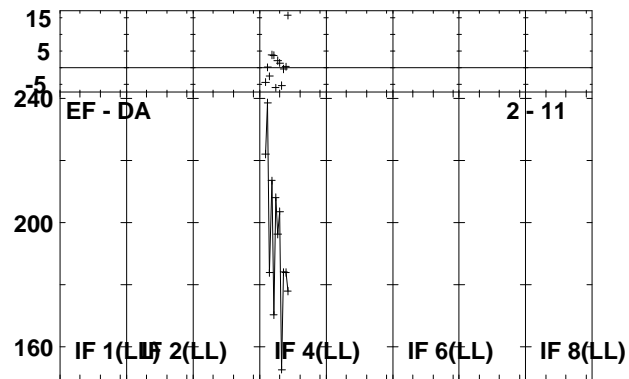
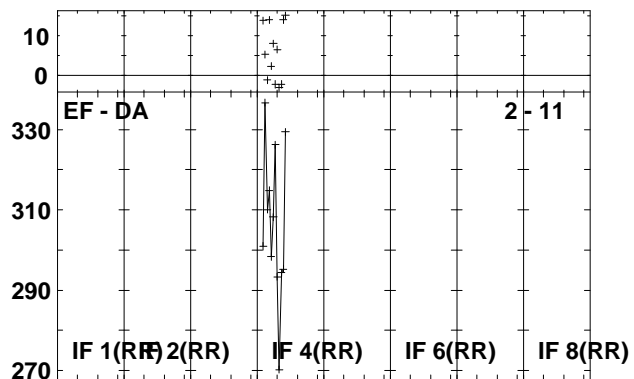
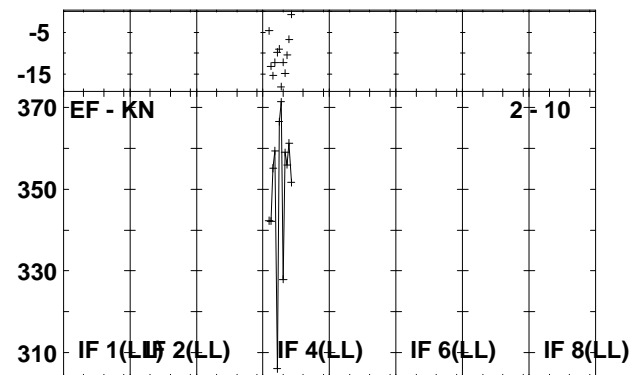
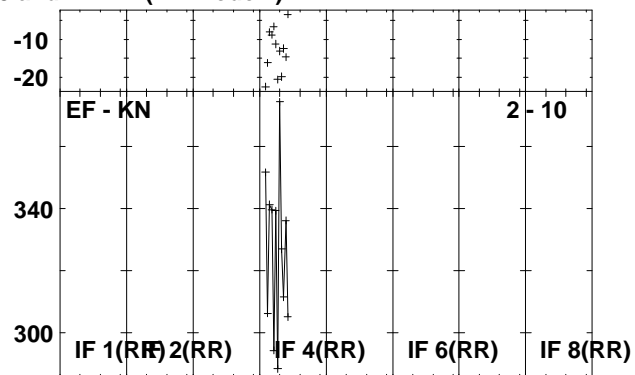
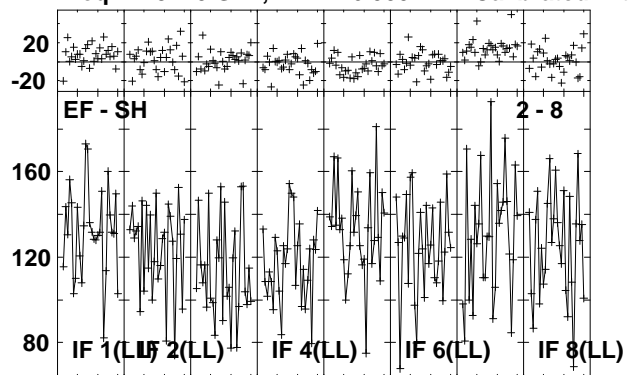

Lower frame: Milli Ampl Jy Top frame: Phas deg  
Vector averaged cross-power spectrum Several baselines displayed  
Timerange: 01/00:02:01 to 01/00:03:27

Plot file version 77 created 24-AUG-2010 08:17:56

IRAS1929 EP064M.UVDATA.1

Freq = 4.9270 GHz, Bw = 16.000 MH Calibrated with CL # 3 and BP # 1 (BP mode 1)

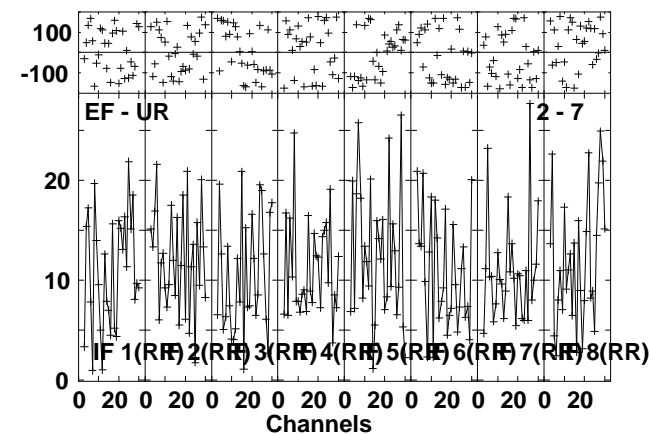
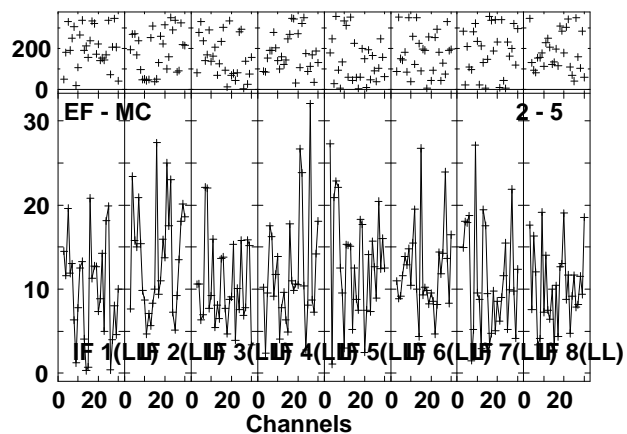
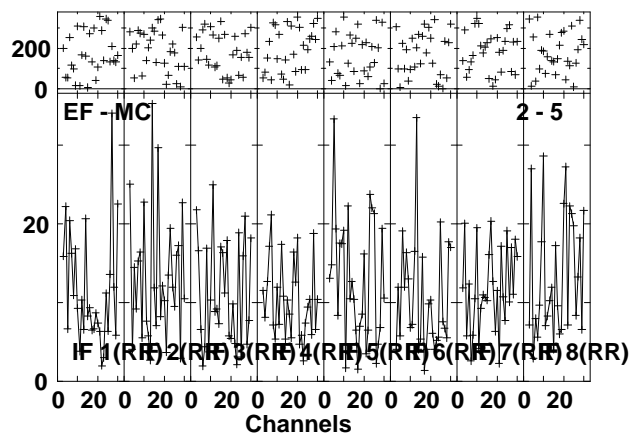
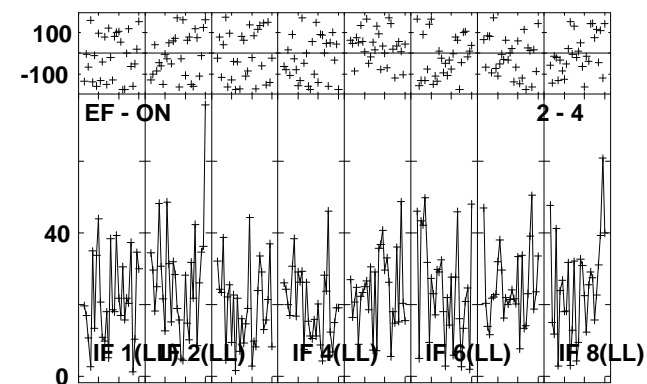
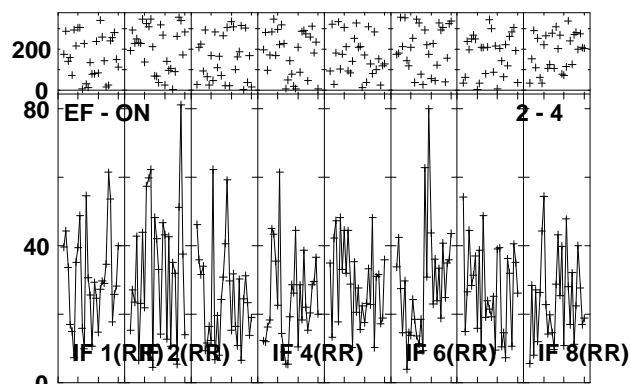
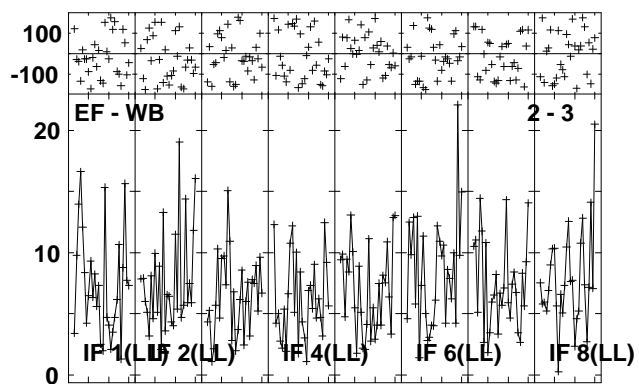
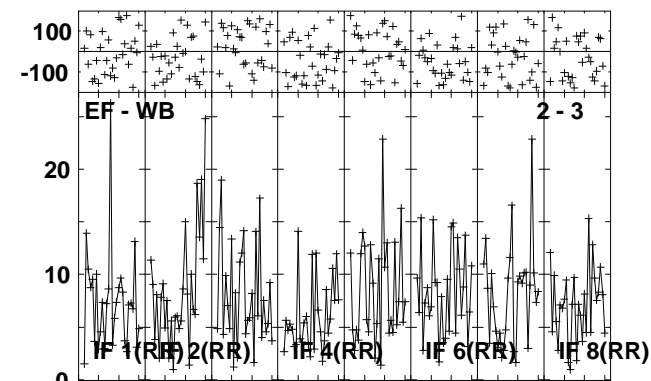
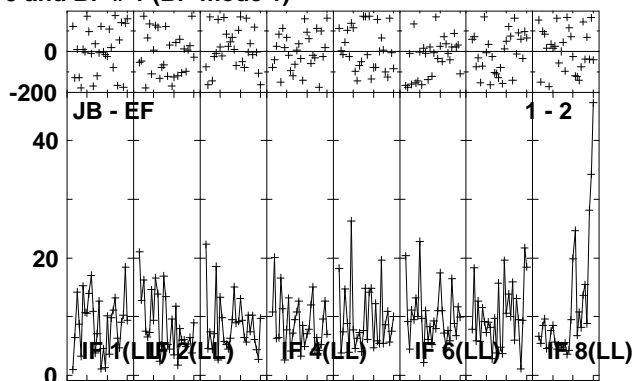
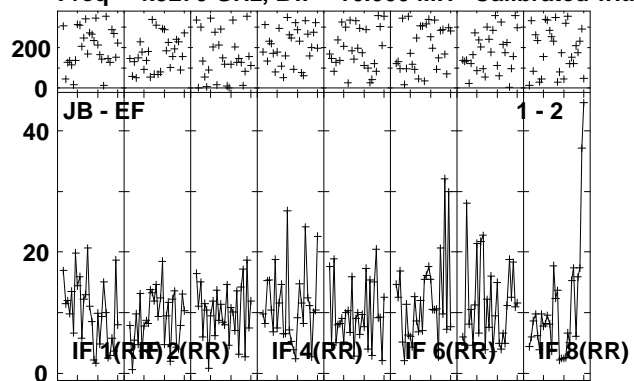

Lower frame: Milli Ampl Jy Top frame: Phas deg  
Vector averaged cross-power spectrum Several baselines displayed  
Timerange: 01/00:03:31 to 01/00:06:59

Plot file version 78 created 24-AUG-2010 08:17:59

IRAS1929 EP064M.UVDATA.1

Freq = 4.9270 GHz, Bw = 16.000 MH Calibrated with CL # 3 and BP # 1 (BP mode 1)

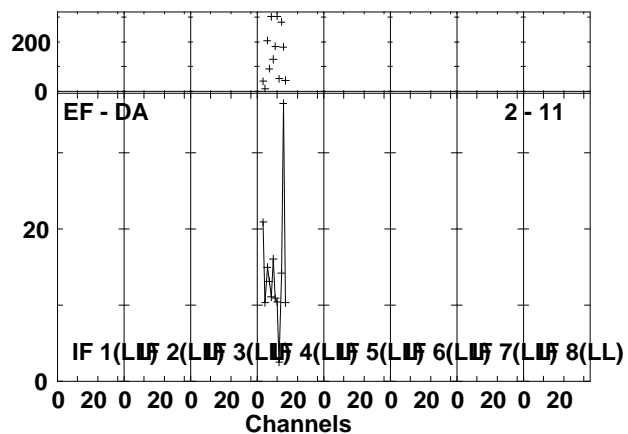
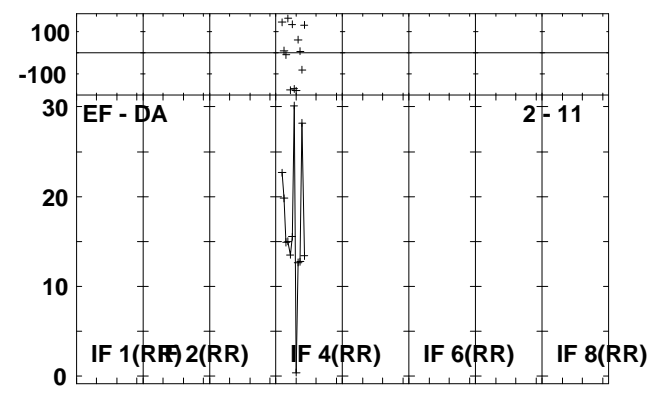
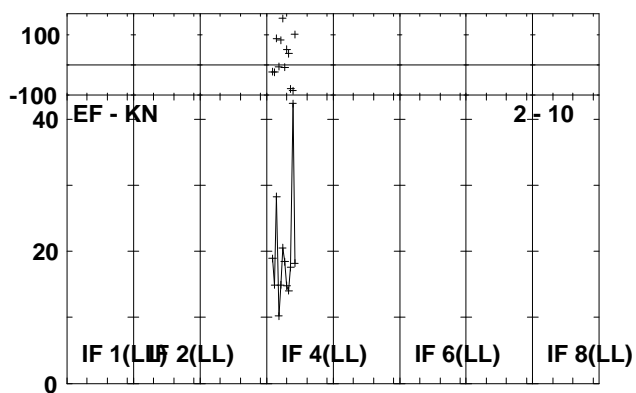
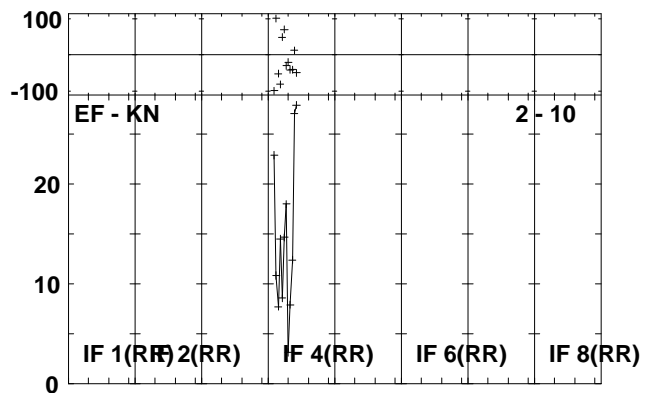
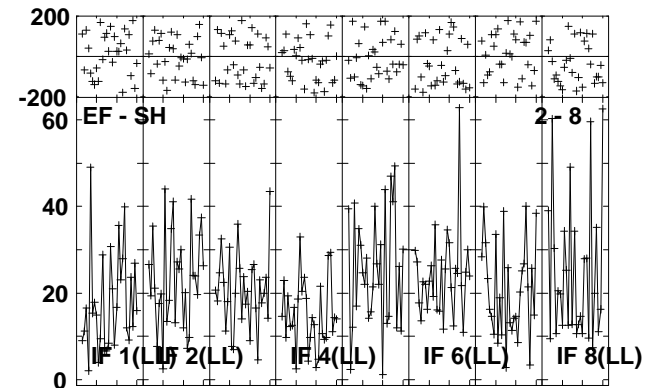
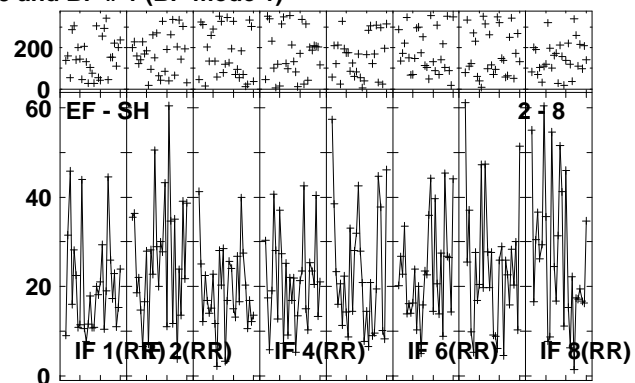
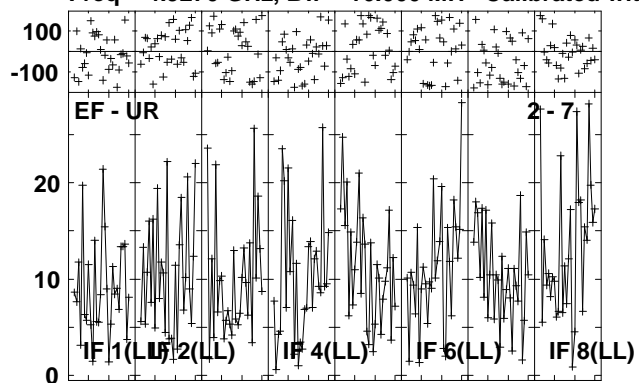

Lower frame: Milli Ampl Jy Top frame: Phas deg  
Vector averaged cross-power spectrum Several baselines displayed  
Timerange: 01/00:03:31 to 01/00:06:59

Plot file version 79 created 24-AUG-2010 08:18:03  
 J1941-05 EP064M.UVDATA.1  
 Freq = 4.9270 GHz, Bw = 16.000 MH Calibrated with CL # 3 and BP # 1 (BP mode 1)

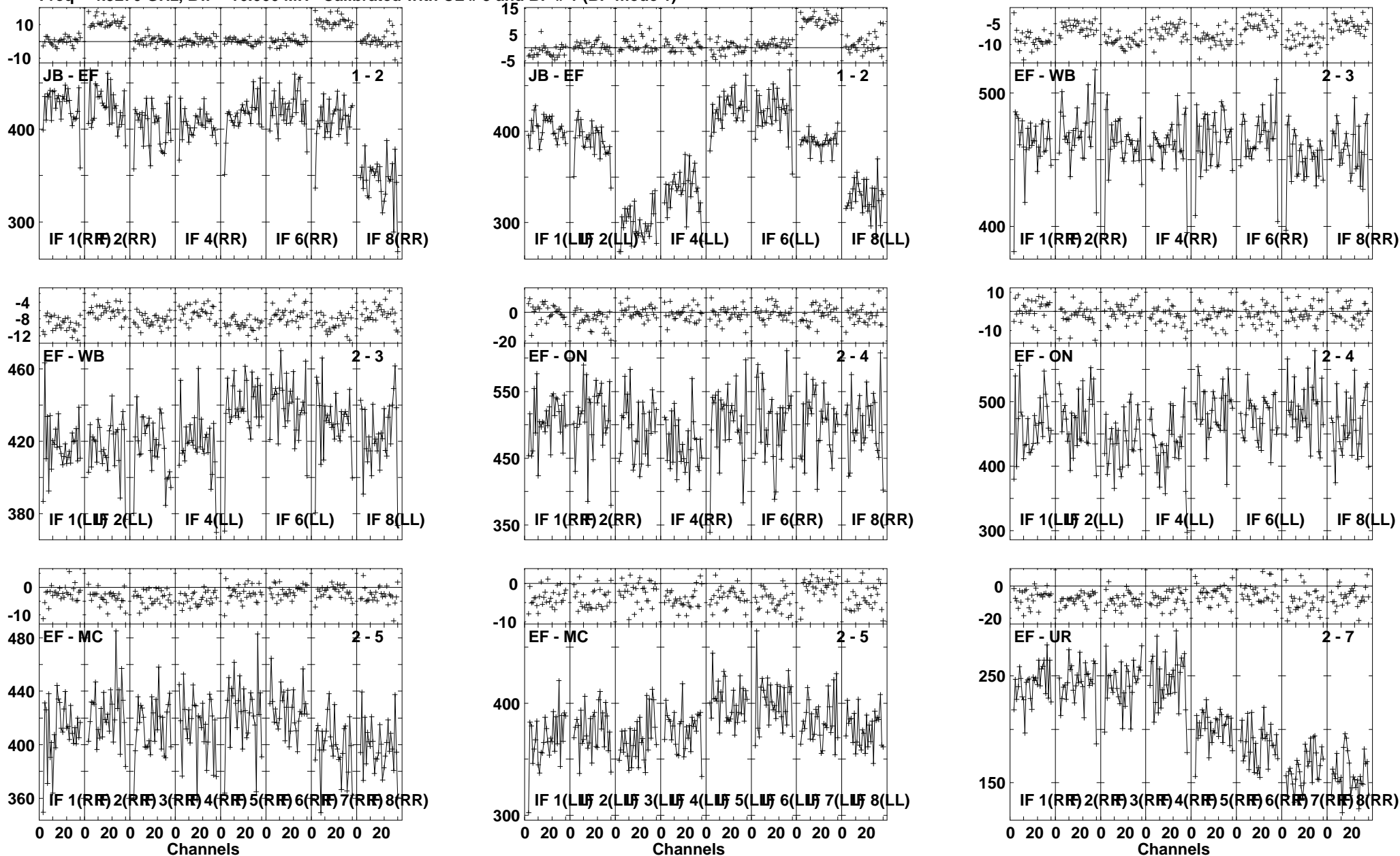

Lower frame: Milli Ampl Jy Top frame: Phas deg  
 Vector averaged cross-power spectrum Several baselines displayed  
 Timerange: 01/00:07:01 to 01/00:08:29





Plot file version 81 created 24-AUG-2010 08:18:06

IRAS1929 EP064M.UVDATA.1

Freq = 4.9270 GHz, Bw = 16.000 MH Calibrated with CL # 3 and BP # 1 (BP mode 1)

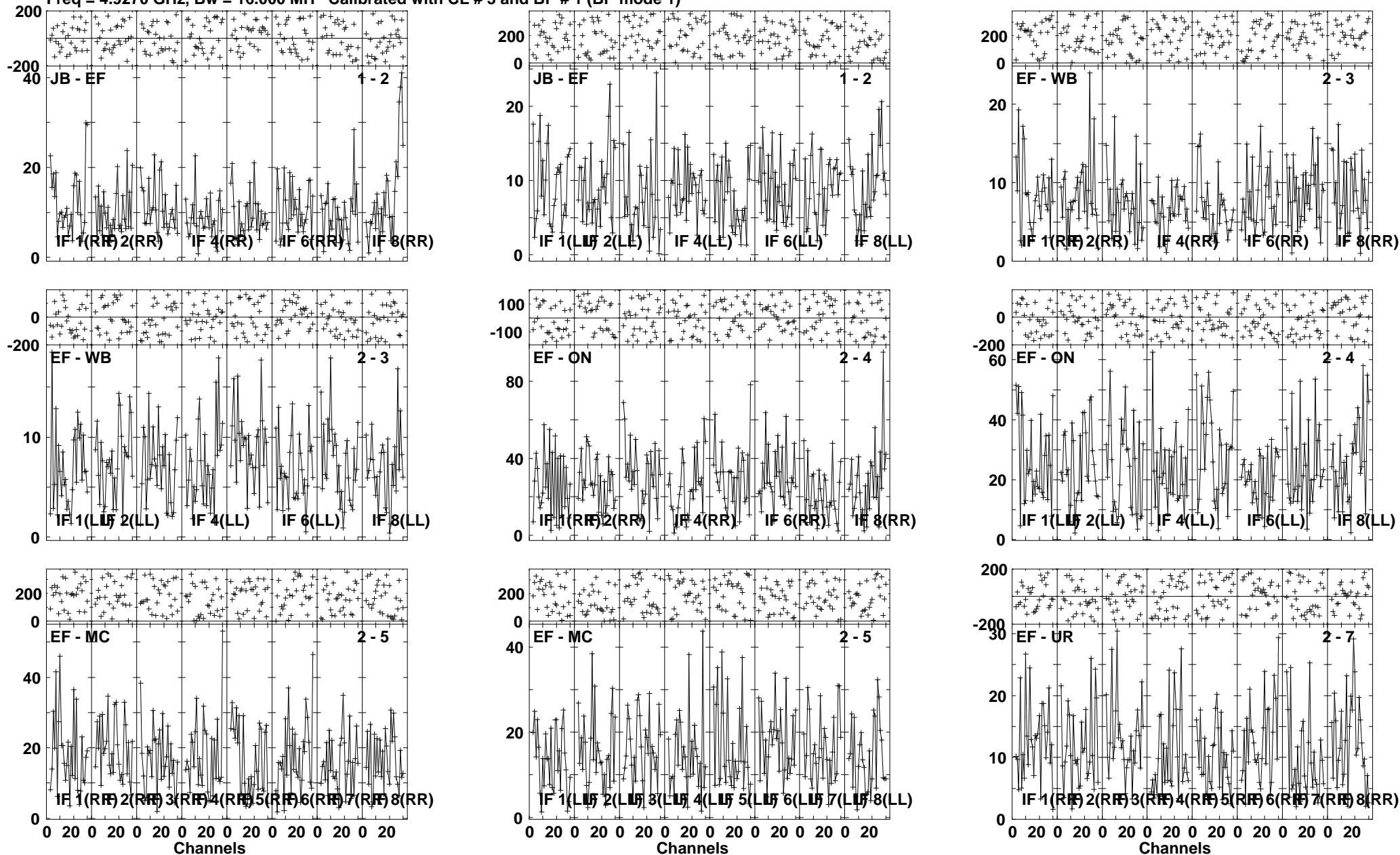

Lower frame: Milli Ampl Jy Top frame: Phas deg  
Vector averaged cross-power spectrum Several baselines displayed  
Timerange: 01/00:08:31 to 01/00:11:59

Plot file version 82 created 24-AUG-2010 08:18:10

IRAS1929 EP064M.UVDATA.1

Freq = 4.9270 GHz, Bw = 16.000 MH Calibrated with CL # 3 and BP # 1 (BP mode 1)

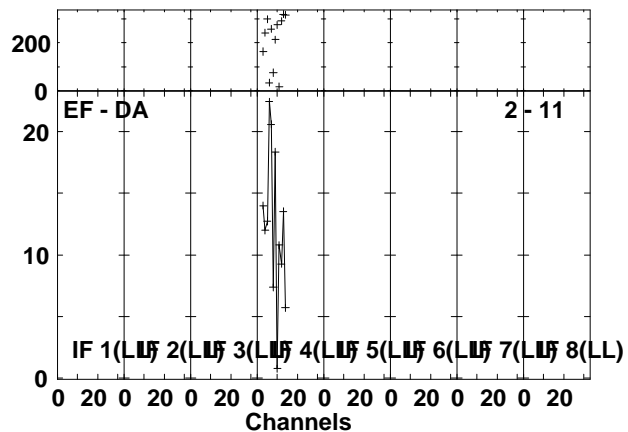
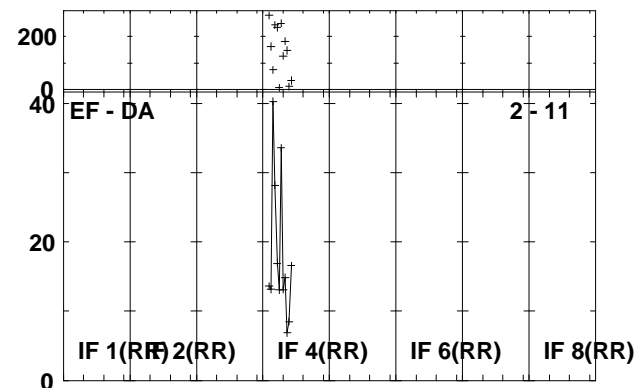
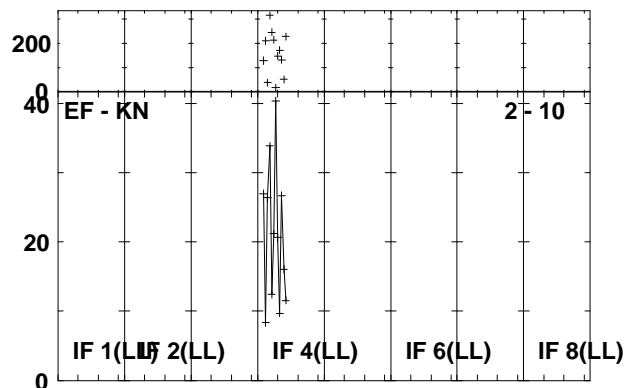
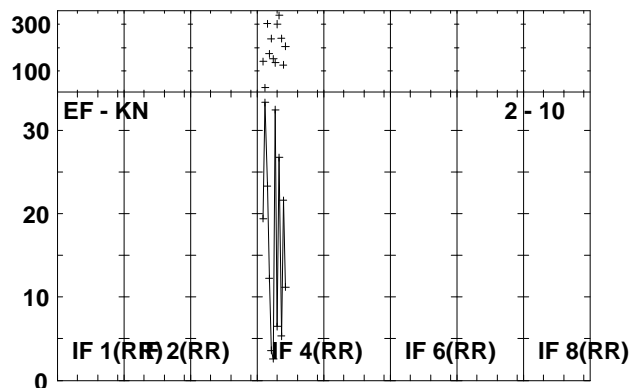
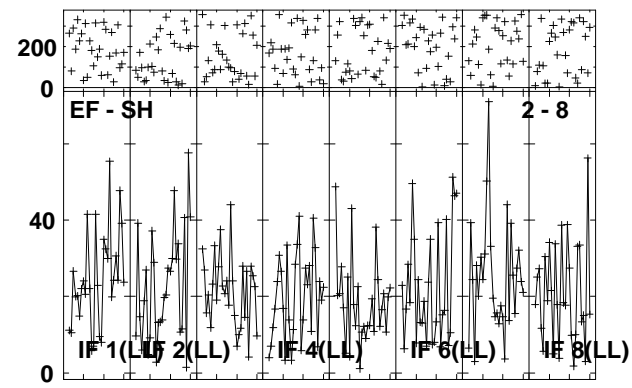
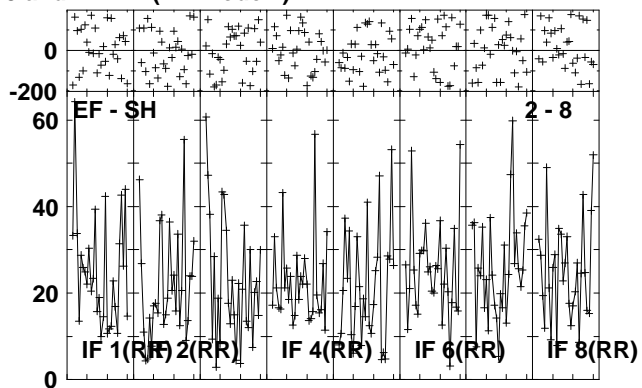
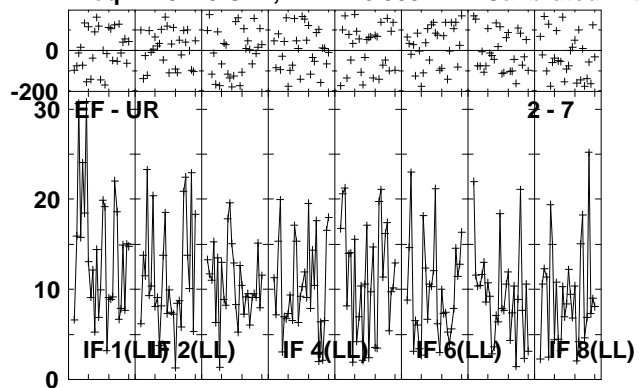

Lower frame: Milli Ampl Jy Top frame: Phas deg  
Vector averaged cross-power spectrum Several baselines displayed  
Timerange: 01/00:08:31 to 01/00:11:59



Plot file version 84 created 24-AUG-2010 08:18:14

J1941-05 EP064M.UVDATA.1

Freq = 4.9270 GHz, Bw = 16.000 MH Calibrated with CL # 3 and BP # 1 (BP mode 1)

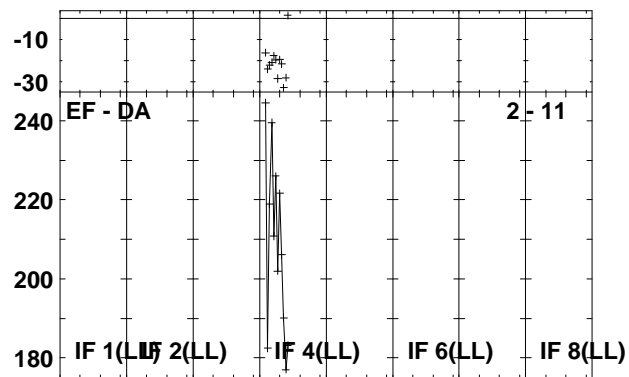
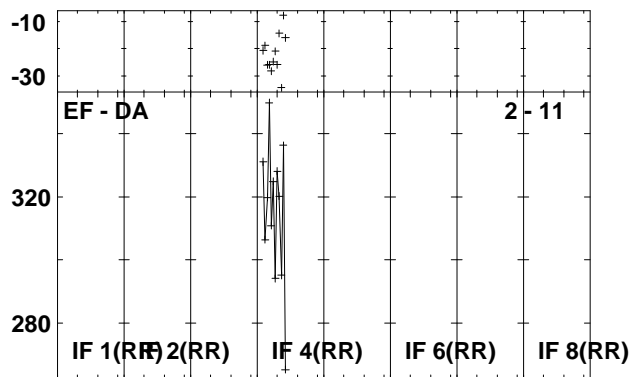
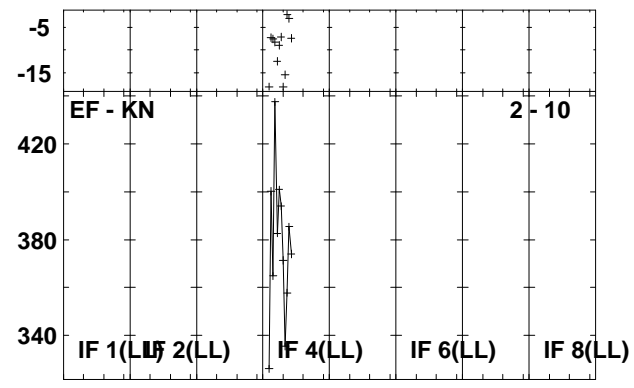
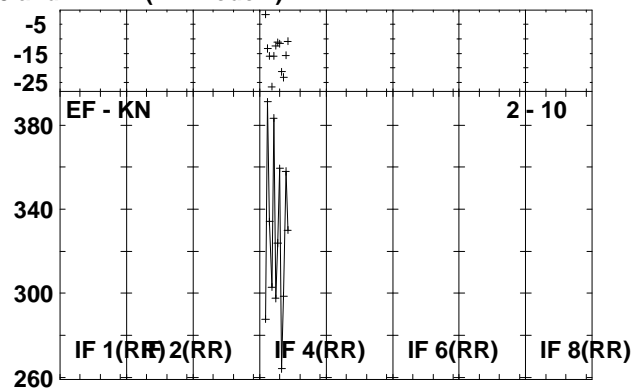
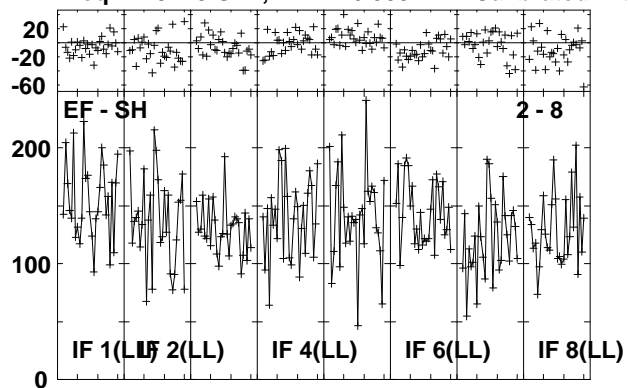

Lower frame: Milli Ampl Jy Top frame: Phas deg  
Vector averaged cross-power spectrum Several baselines displayed  
Timerange: 01/00:12:01 to 01/00:13:29

Plot file version 85 created 24-AUG-2010 08:18:16

IRAS1929 EP064M.UVDATA.1

Freq = 4.9270 GHz, Bw = 16.000 MH Calibrated with CL # 3 and BP # 1 (BP mode 1)

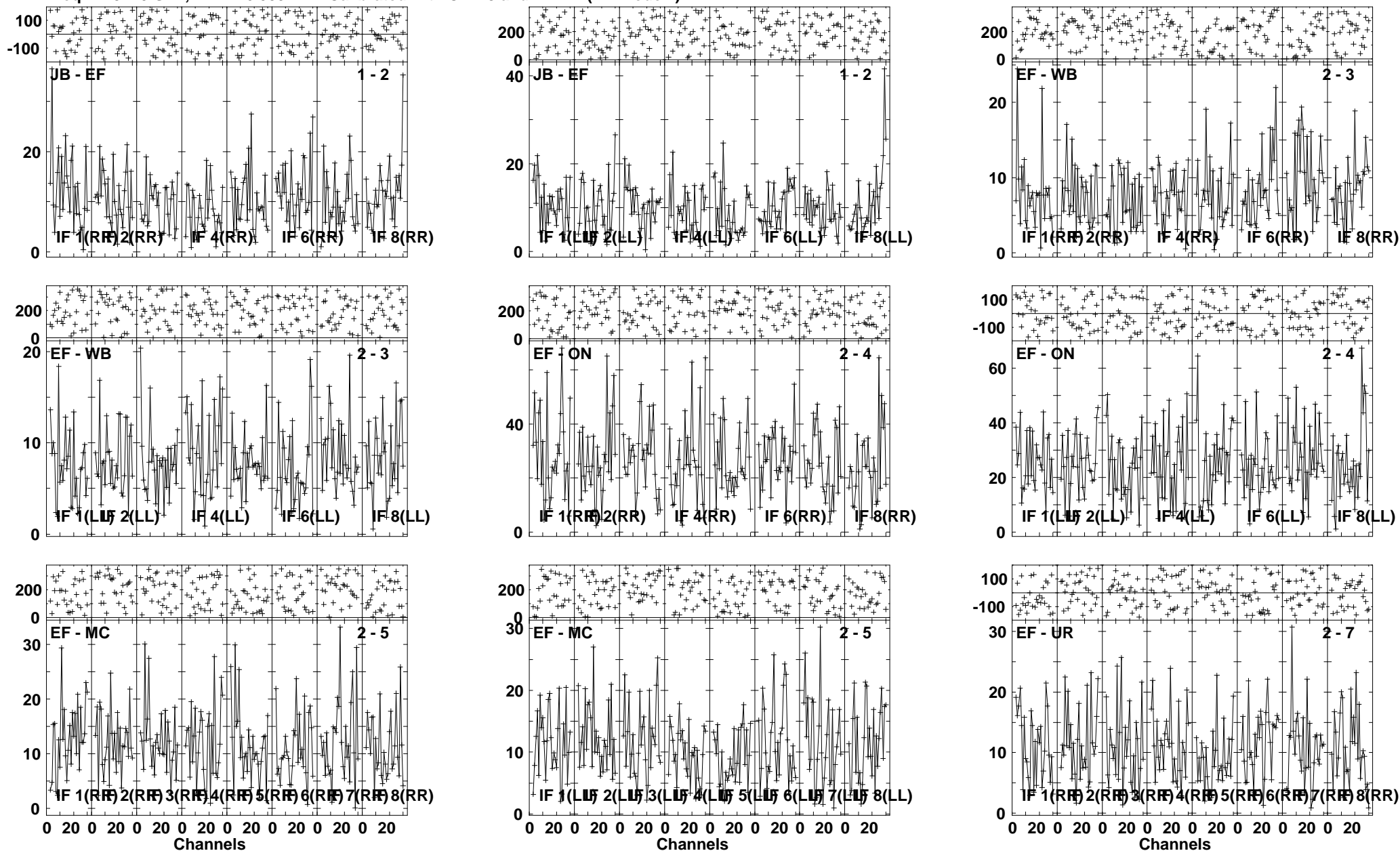

Lower frame: Milli Ampl Jy Top frame: Phas deg  
Vector averaged cross-power spectrum Several baselines displayed  
Timerange: 01/00:13:31 to 01/00:16:59



Plot file version 87 created 24-AUG-2010 08:18:23

J1941-05 EP064M.UVDATA.1

Freq = 4.9270 GHz, Bw = 16.000 MH Calibrated with CL # 3 and BP # 1 (BP mode 1)

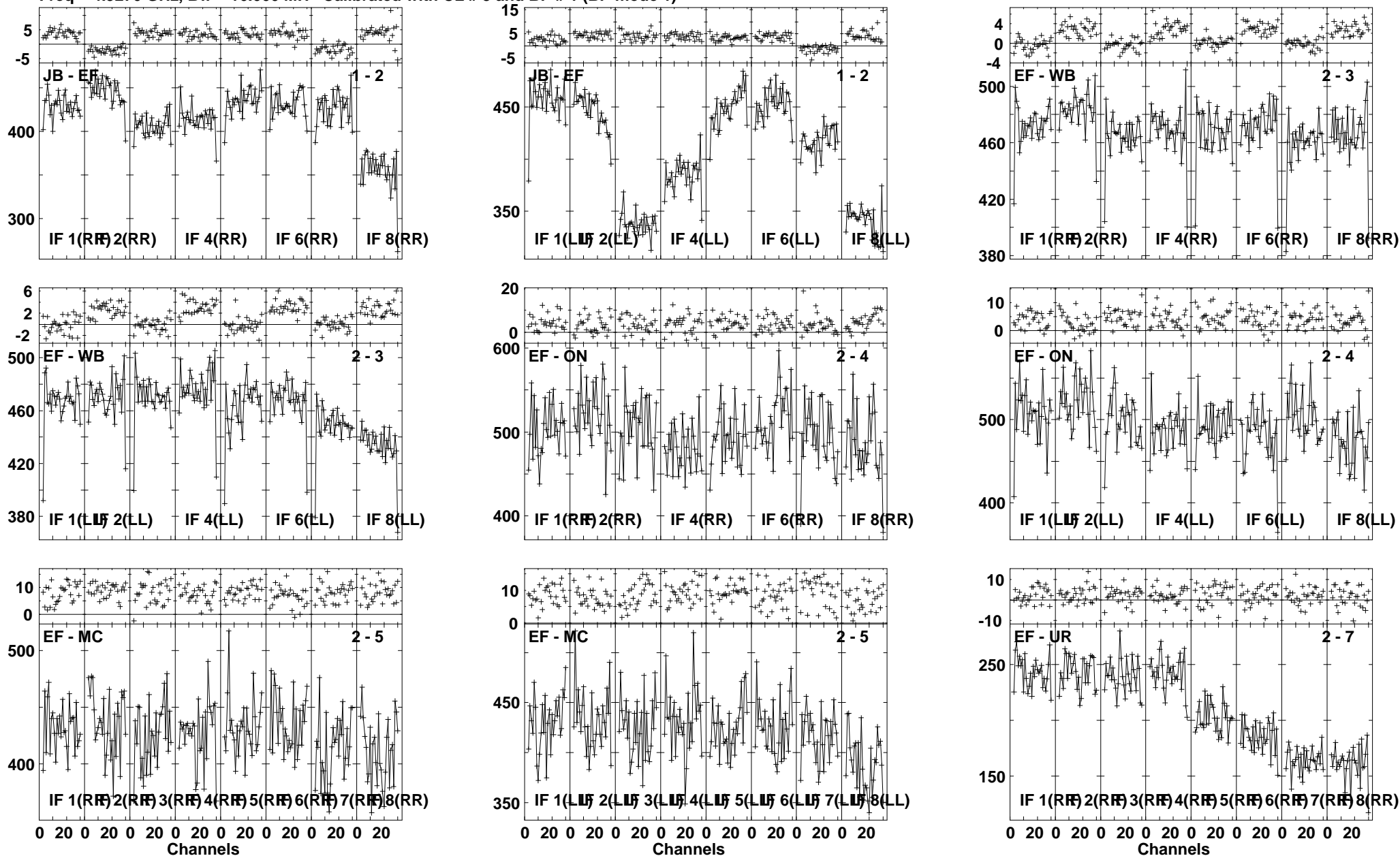

Lower frame: Milli Ampl Jy Top frame: Phas deg  
Vector averaged cross-power spectrum Several baselines displayed  
Timerange: 01/00:18:01 to 01/00:19:29





Plot file version 89 created 24-AUG-2010 08:18:27

IRAS1929 EP064M.UVDATA.1

Freq = 4.9270 GHz, Bw = 16.000 MH Calibrated with CL # 3 and BP # 1 (BP mode 1)

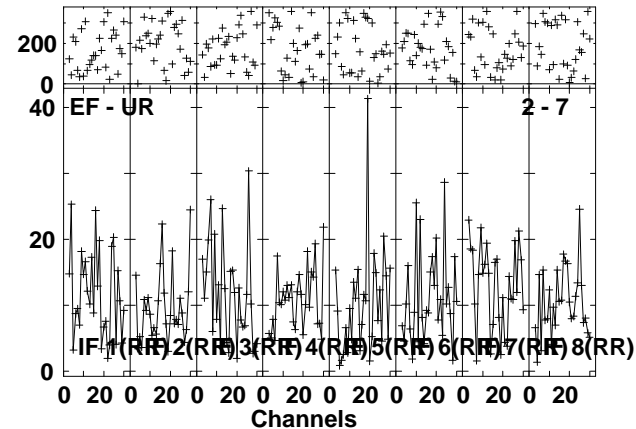
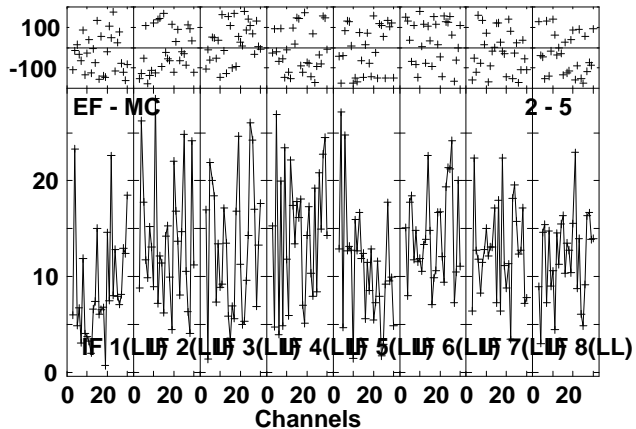
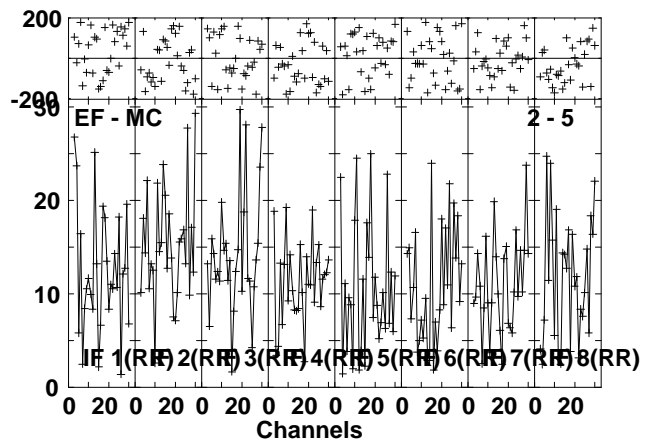
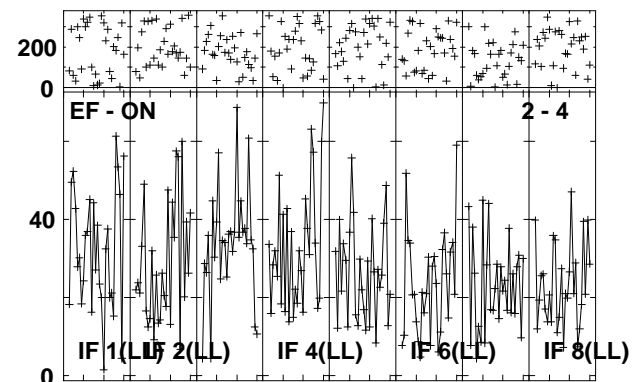
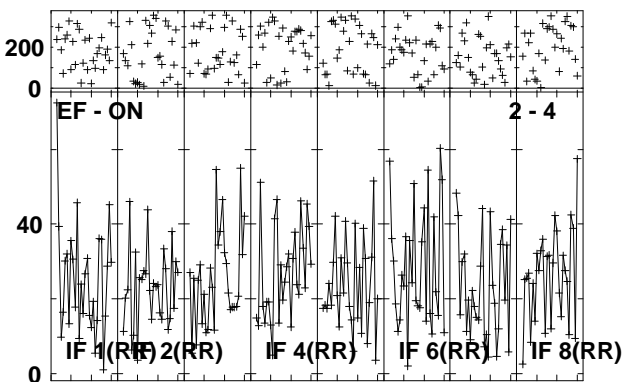
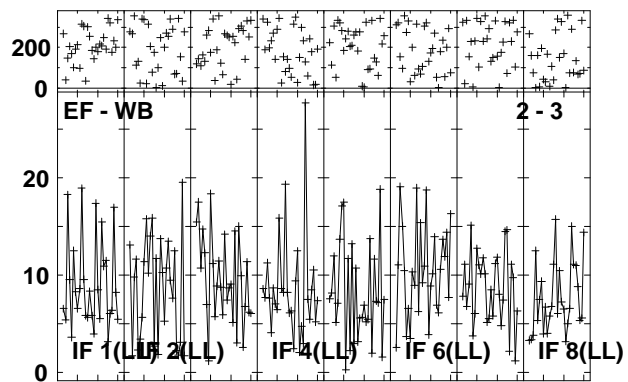
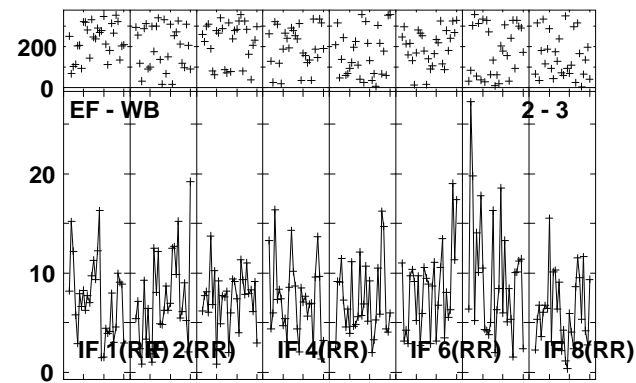
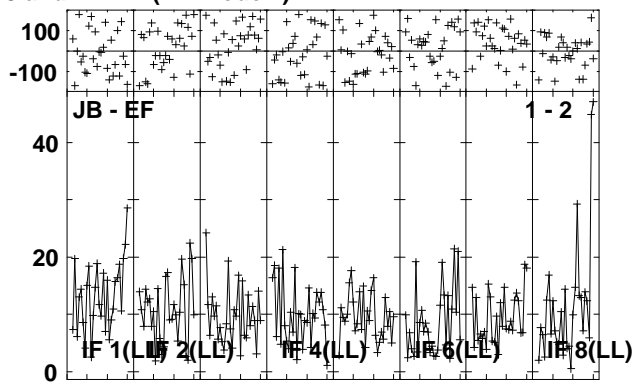
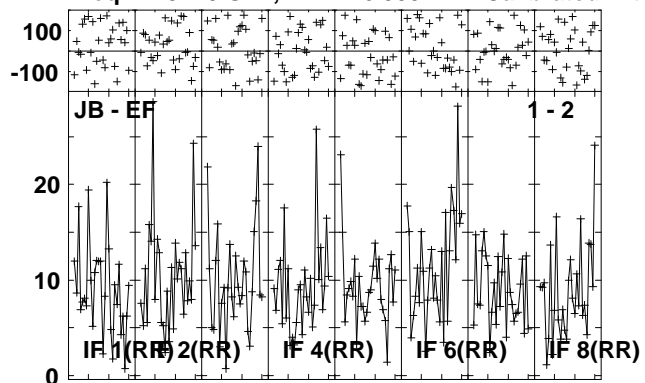

Lower frame: Milli Ampl Jy Top frame: Phas deg  
Vector averaged cross-power spectrum Several baselines displayed  
Timerange: 01/00:19:31 to 01/00:22:59

Plot file version 90 created 24-AUG-2010 08:18:30

IRAS1929 EP064M.UVDATA.1

Freq = 4.9270 GHz, Bw = 16.000 MH Calibrated with CL # 3 and BP # 1 (BP mode 1)

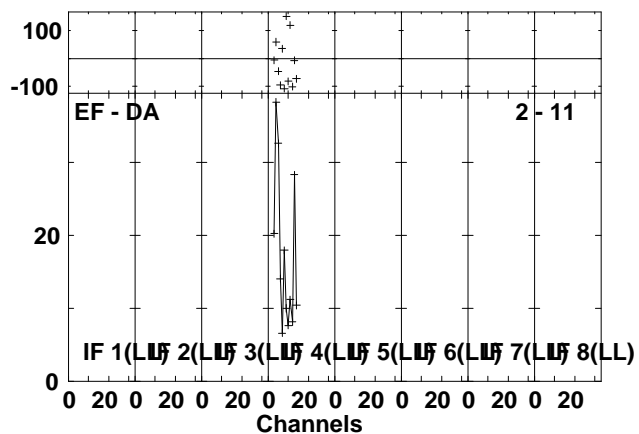
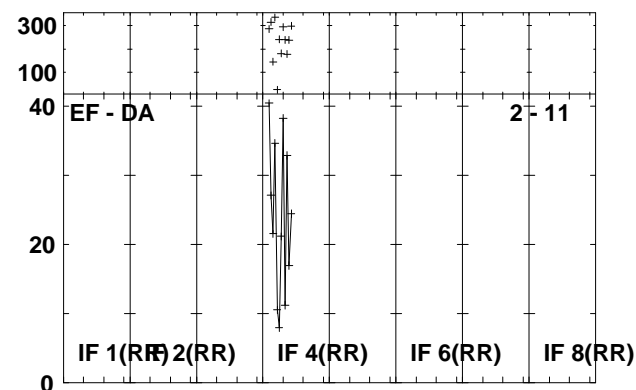
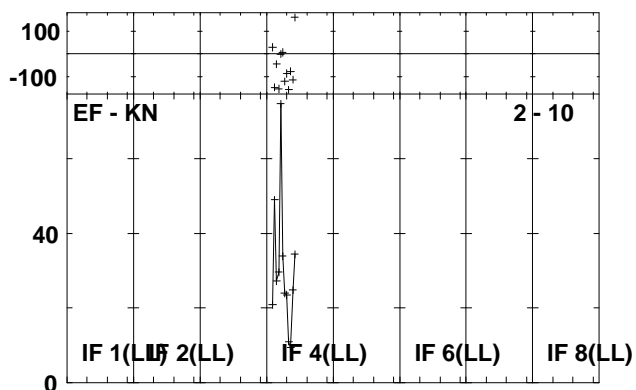
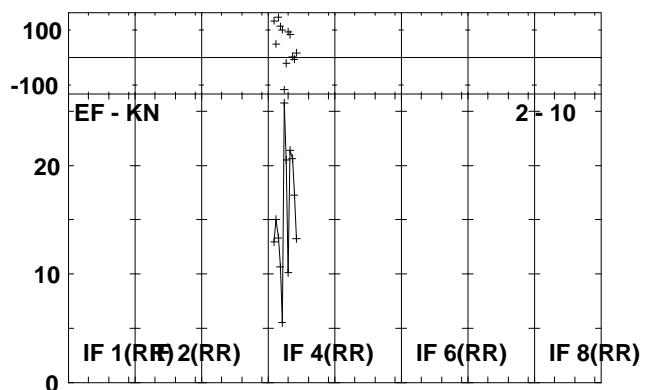
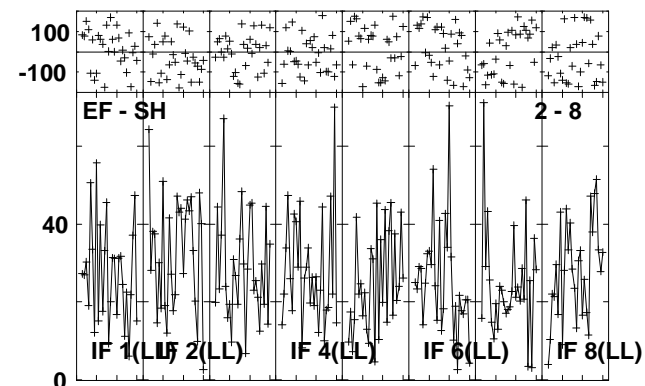
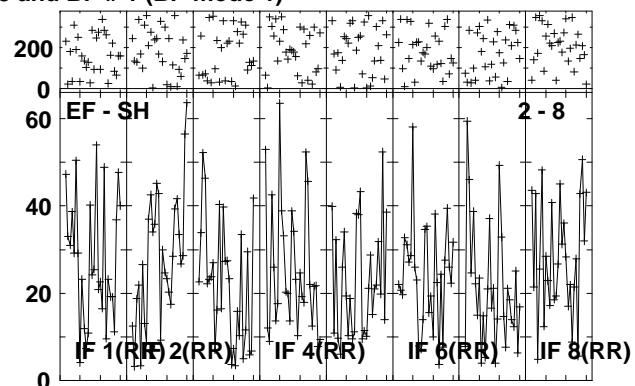
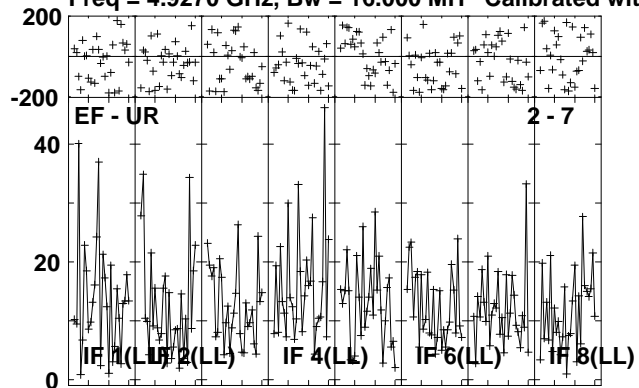

Lower frame: Milli Ampl Jy Top frame: Phas deg

Vector averaged cross-power spectrum Several baselines displayed

Timerange: 01/00:19:31 to 01/00:22:59

Plot file version 91 created 24-AUG-2010 08:18:34

J1941-05 EP064M.UVDATA.1

Freq = 4.9270 GHz, Bw = 16.000 MH Calibrated with CL # 3 and BP # 1 (BP mode 1)

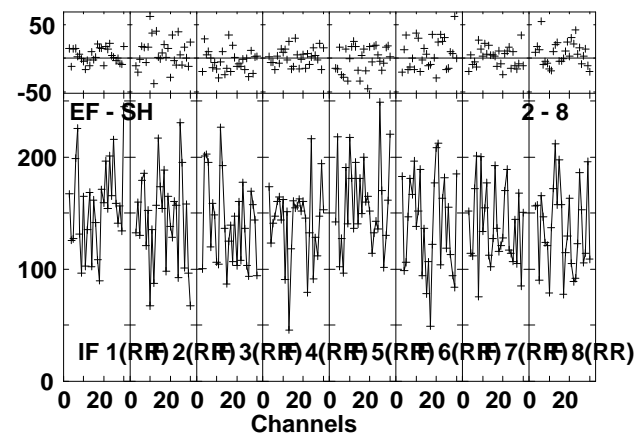
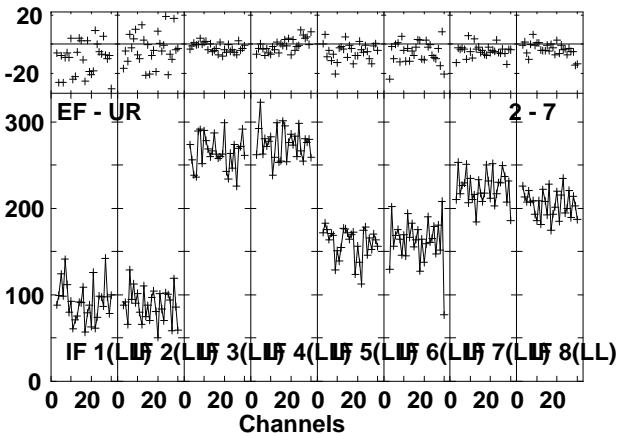
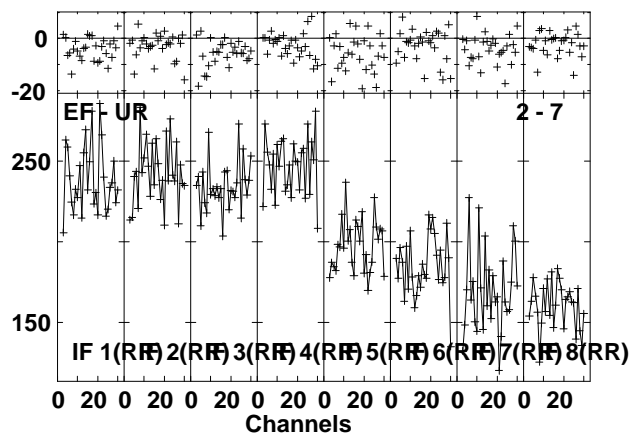
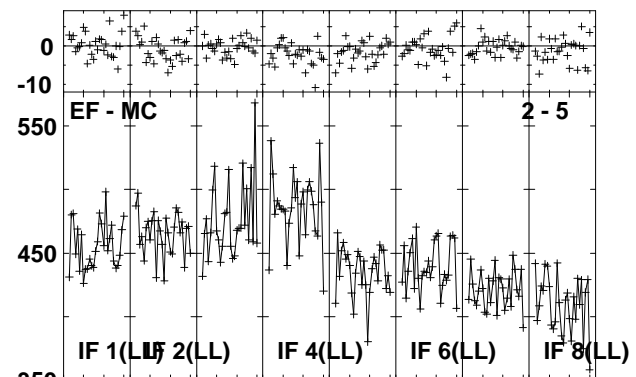
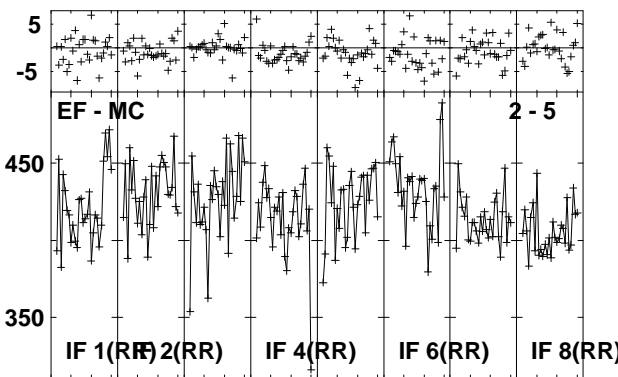
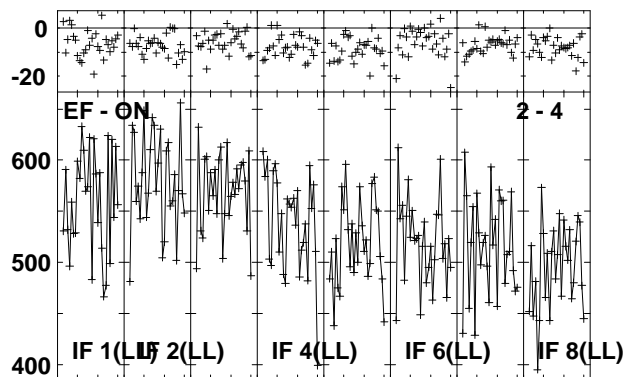
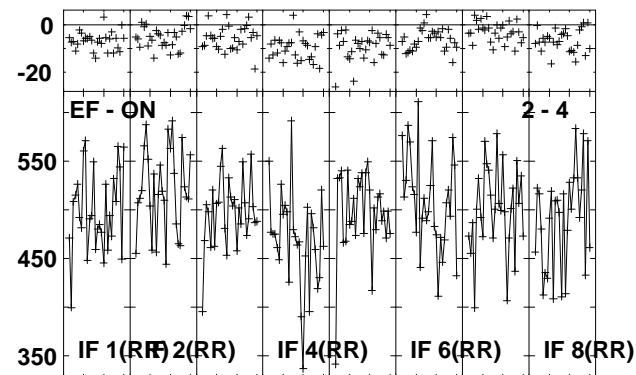
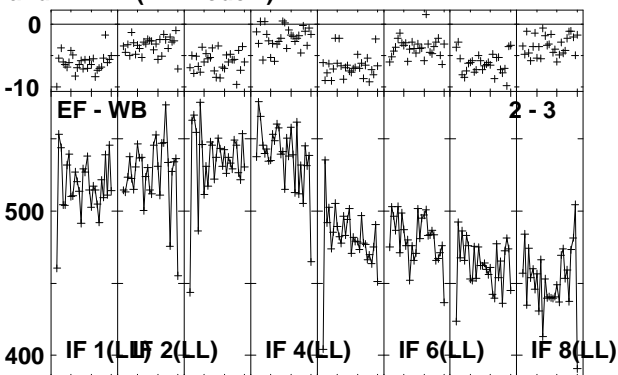
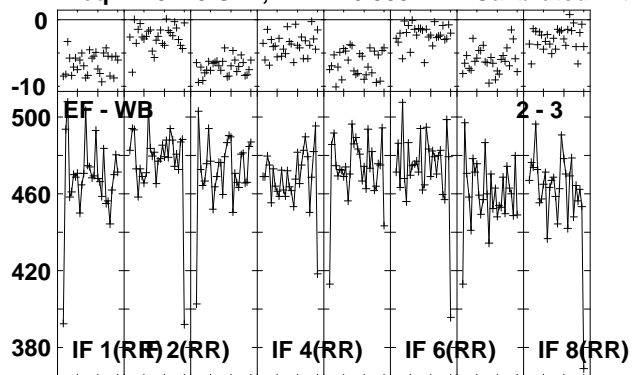

Lower frame: Milli Ampl Jy Top frame: Phas deg  
Vector averaged cross-power spectrum Several baselines displayed  
Timerange: 01/00:23:01 to 01/00:24:29

Plot file version 92 created 24-AUG-2010 08:18:35

J1941-05 EP064M.UVDATA.1

Freq = 4.9270 GHz, Bw = 16.000 MH Calibrated with CL # 3 and BP # 1 (BP mode 1)

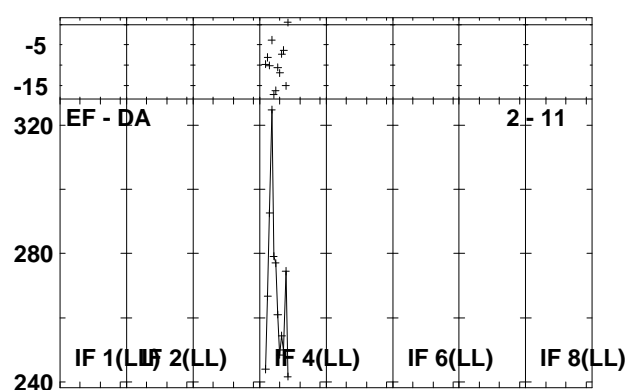
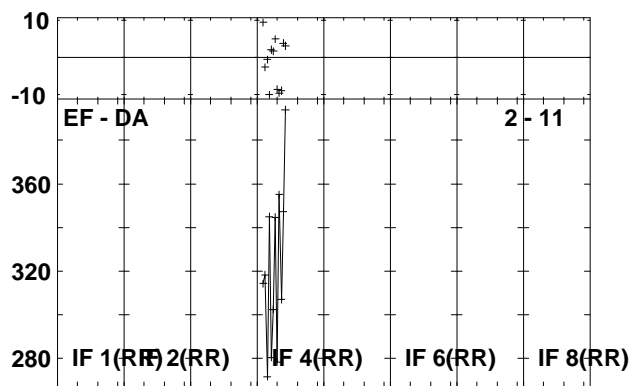
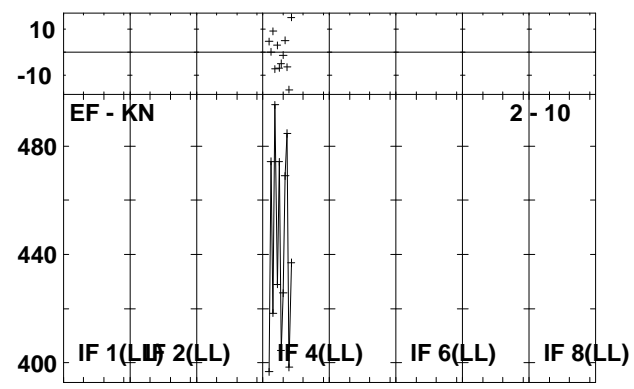
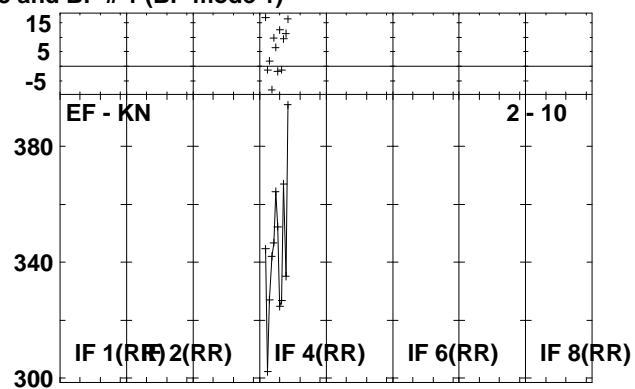
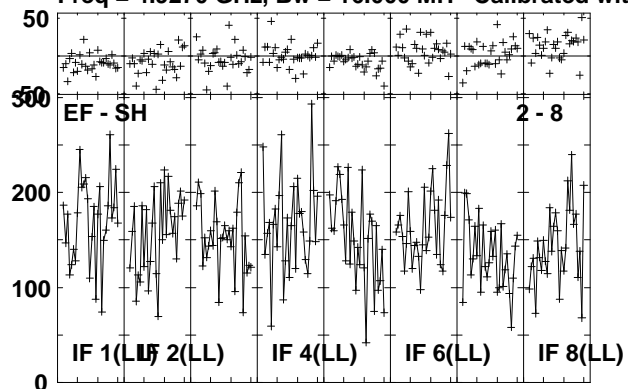

Lower frame: Milli Ampl Jy Top frame: Phas deg  
Vector averaged cross-power spectrum Several baselines displayed  
Timerange: 01/00:23:01 to 01/00:24:29

Plot file version 93 created 24-AUG-2010 08:18:36

IRAS1929 EP064M.UVDATA.1

Freq = 4.9270 GHz, Bw = 16.000 MH Calibrated with CL # 3 and BP # 1 (BP mode 1)

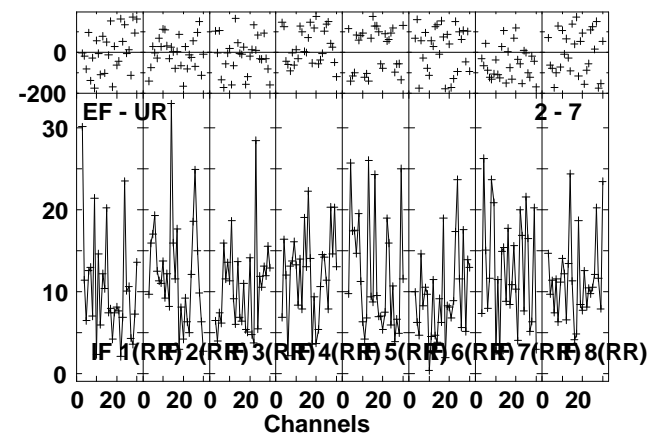
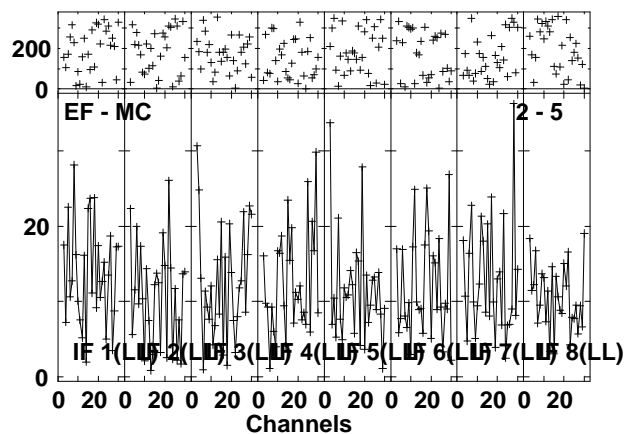
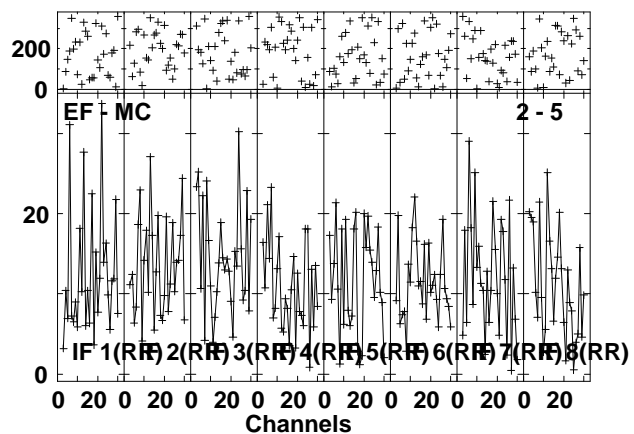
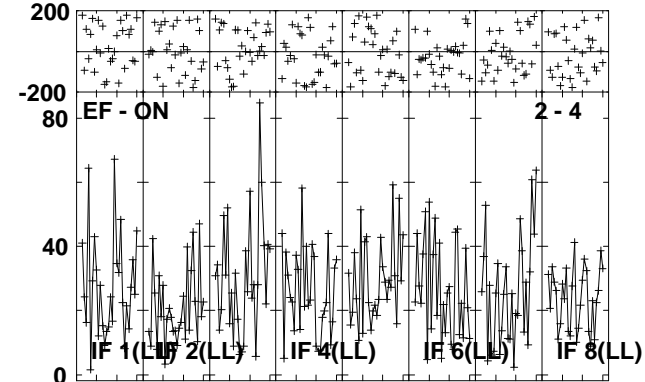
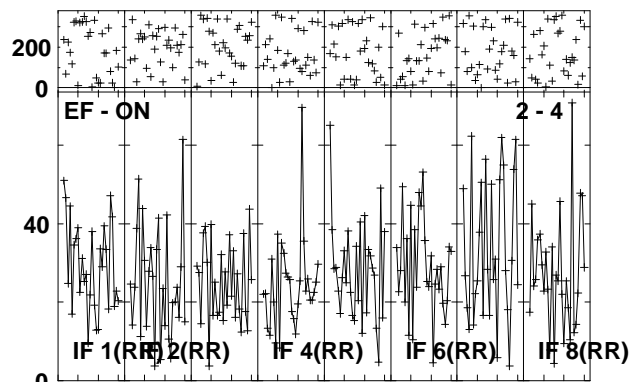
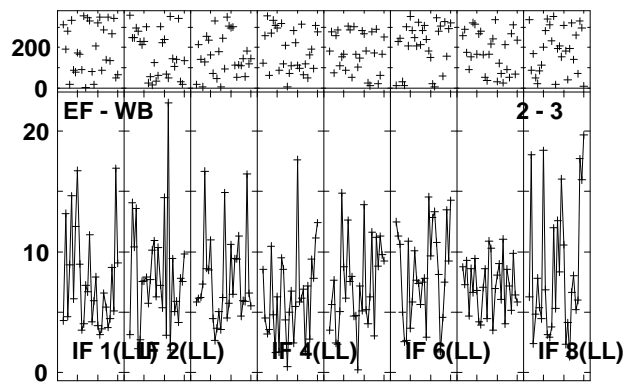
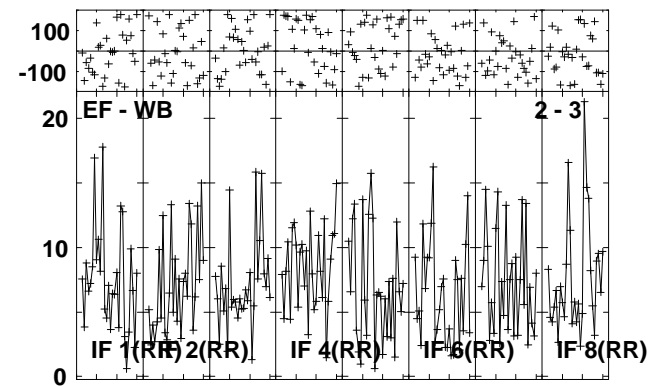
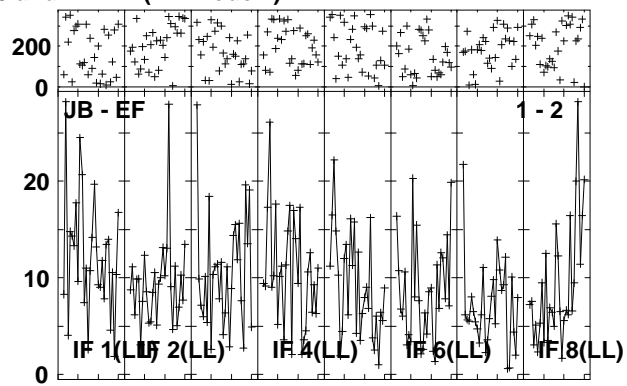
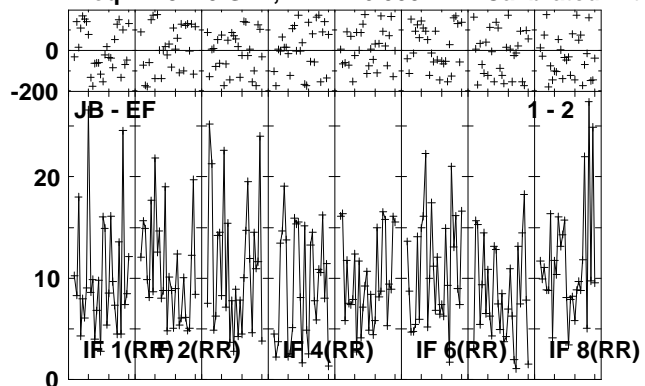

Lower frame: Milli Ampl Jy Top frame: Phas deg  
Vector averaged cross-power spectrum Several baselines displayed  
Timerange: 01/00:24:31 to 01/00:27:59

Plot file version 94 created 24-AUG-2010 08:18:40

IRAS1929 EP064M.UVDATA.1

Freq = 4.9270 GHz, Bw = 16.000 MH Calibrated with CL # 3 and BP # 1 (BP mode 1)

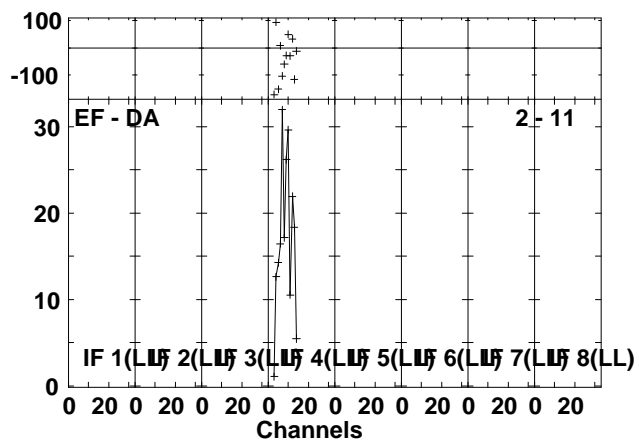
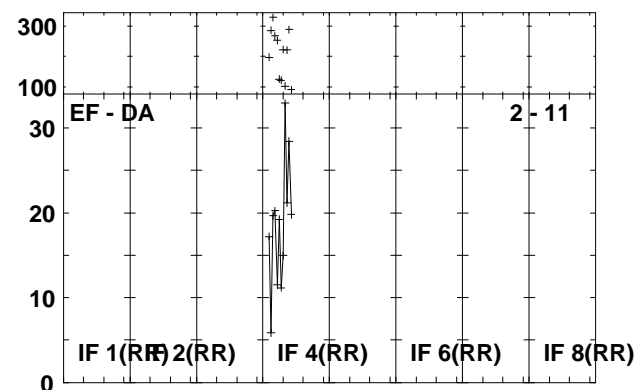
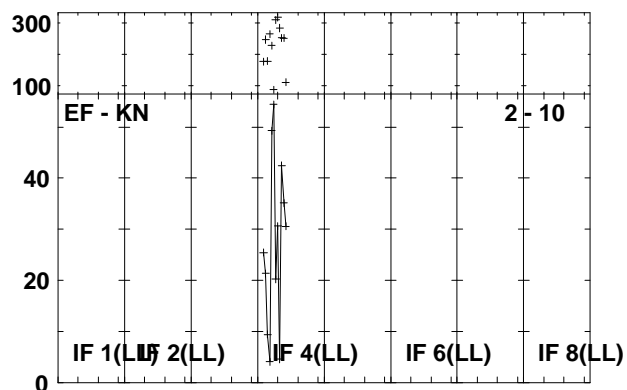
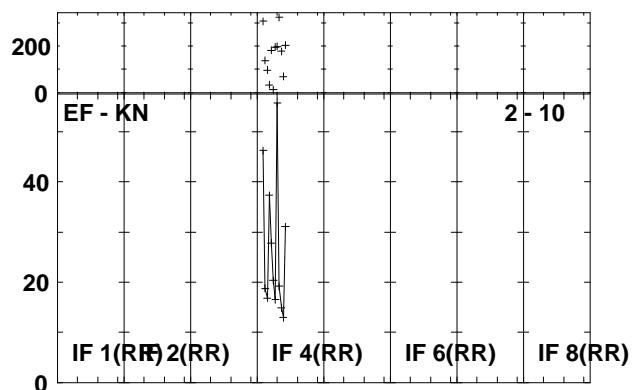
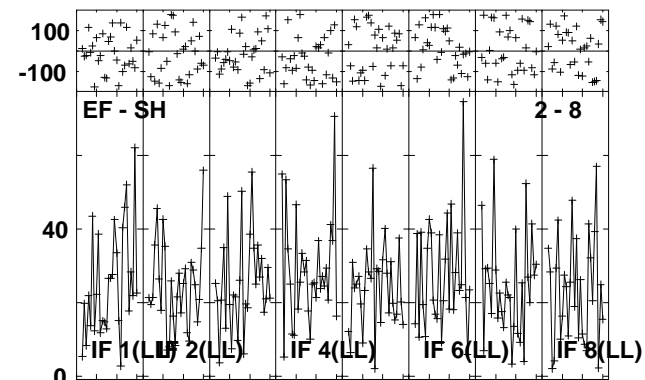
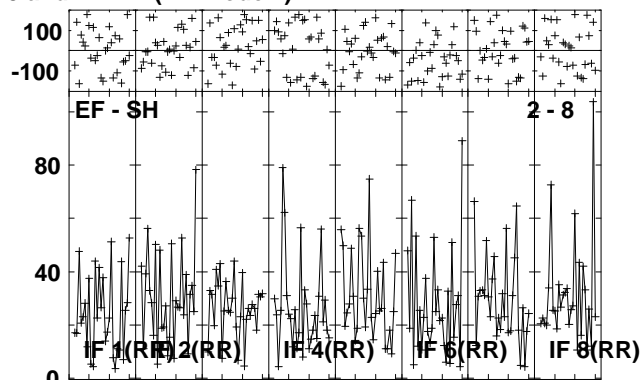
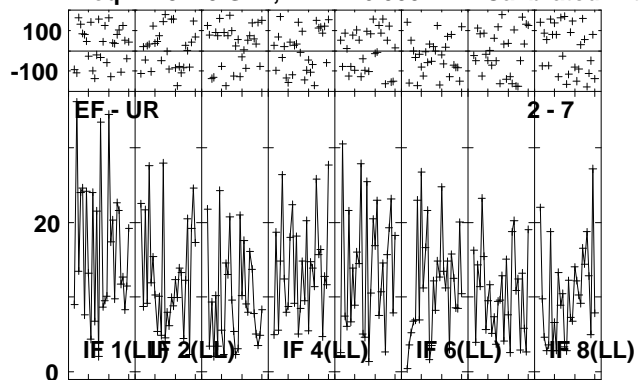

Lower frame: Milli Ampl Jy Top frame: Phas deg  
Vector averaged cross-power spectrum Several baselines displayed  
Timerange: 01/00:24:31 to 01/00:27:59

Plot file version 95 created 24-AUG-2010 08:18:43

J1941-05 EP064M.UVDATA.1

Freq = 4.9270 GHz, Bw = 16.000 MH Calibrated with CL # 3 and BP # 1 (BP mode 1)

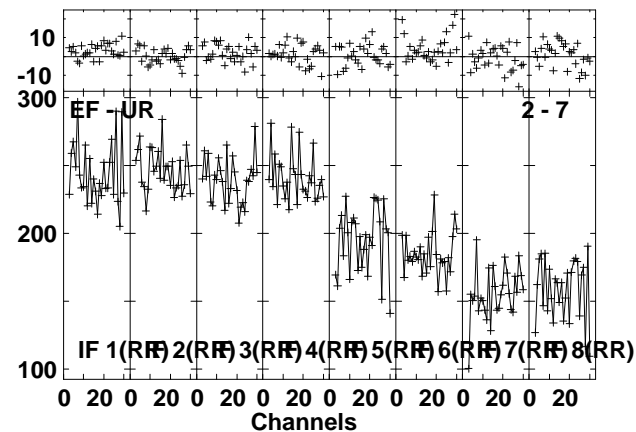
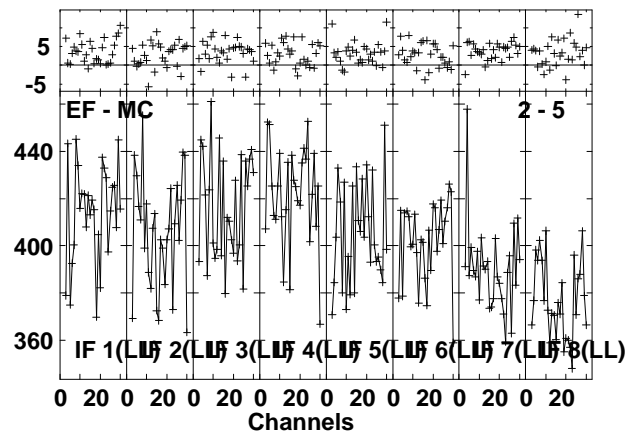
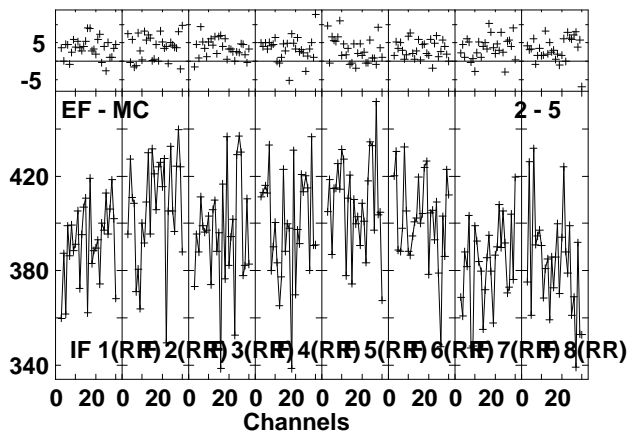
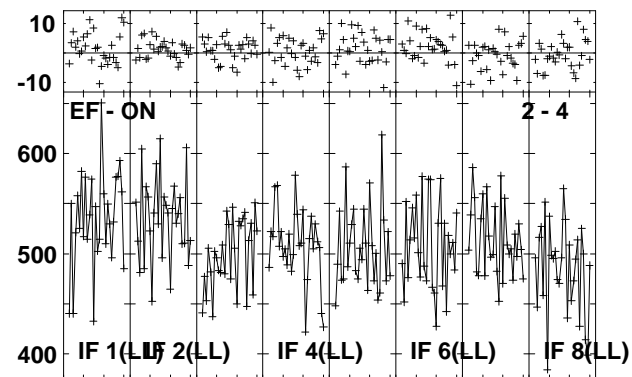
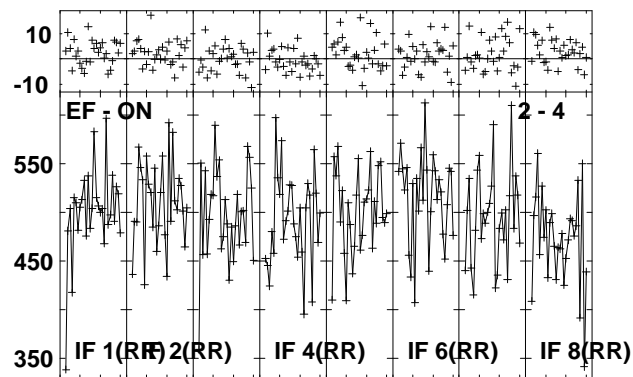
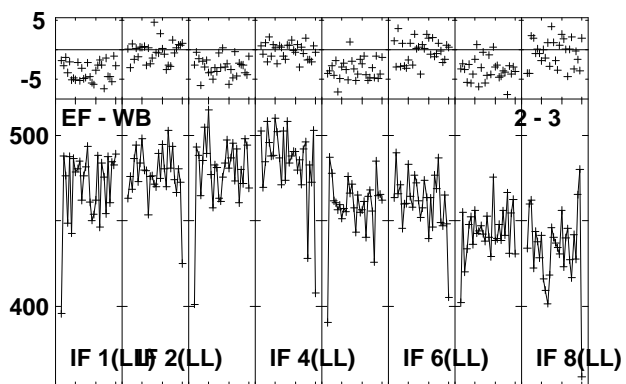
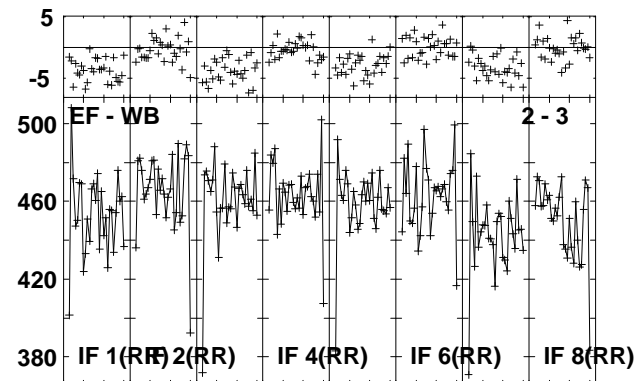
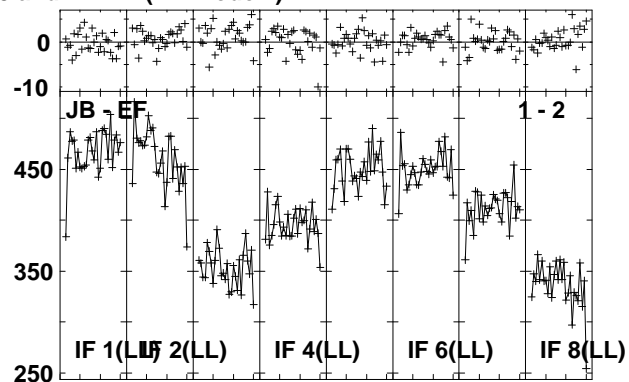
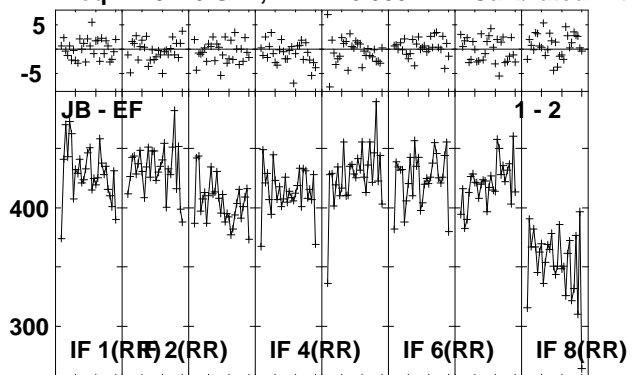

Lower frame: Milli Ampl Jy Top frame: Phas deg  
Vector averaged cross-power spectrum Several baselines displayed  
Timerange: 01/00:28:01 to 01/00:29:29

Plot file version 96 created 24-AUG-2010 08:18:45

J1941-05 EP064M.UVDATA.1

Freq = 4.9270 GHz, Bw = 16.000 MH Calibrated with CL # 3 and BP # 1 (BP mode 1)

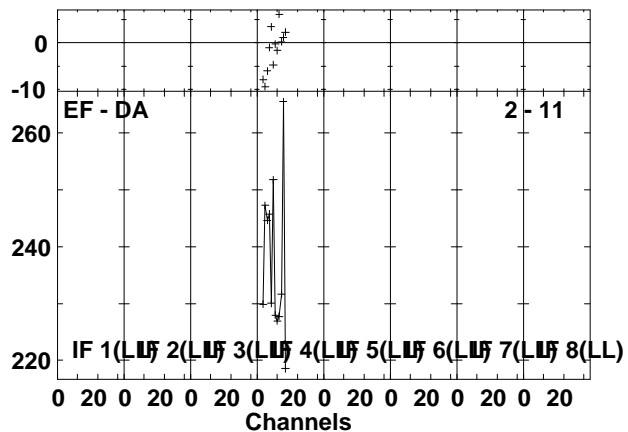
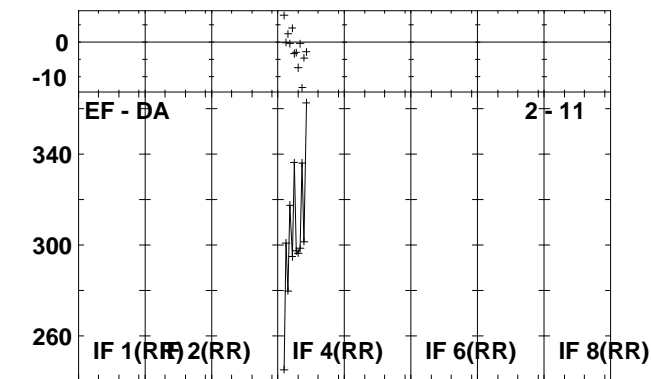
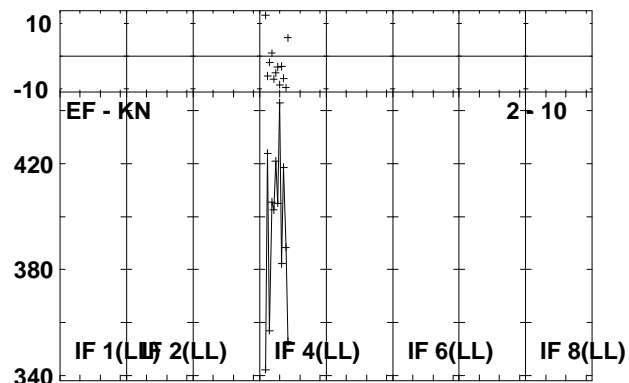
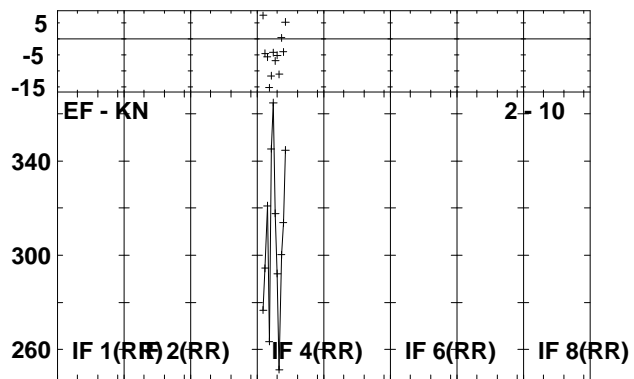
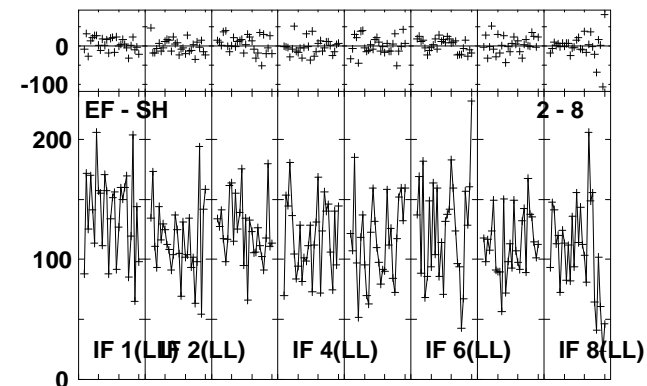
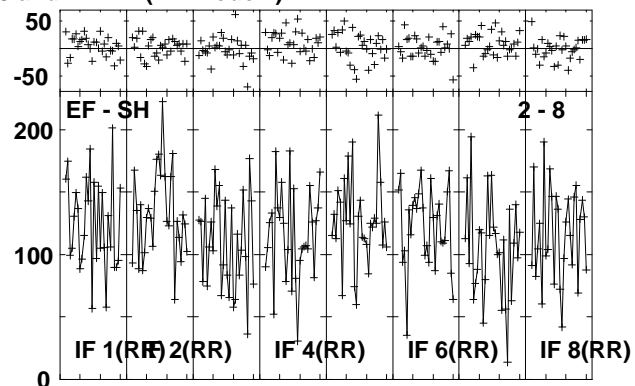
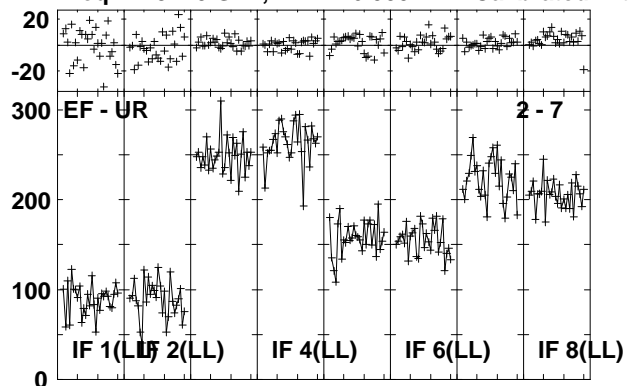

Lower frame: Milli Ampl Jy Top frame: Phas deg  
Vector averaged cross-power spectrum Several baselines displayed  
Timerange: 01/00:28:01 to 01/00:29:29



Plot file version 97 created 24-AUG-2010 08:18:47

IRAS1929 EP064M.UVDATA.1

Freq = 4.9270 GHz, Bw = 16.000 MH Calibrated with CL # 3 and BP # 1 (BP mode 1)

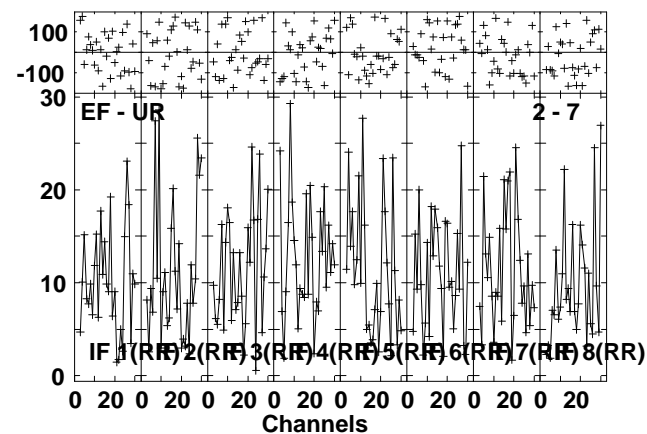
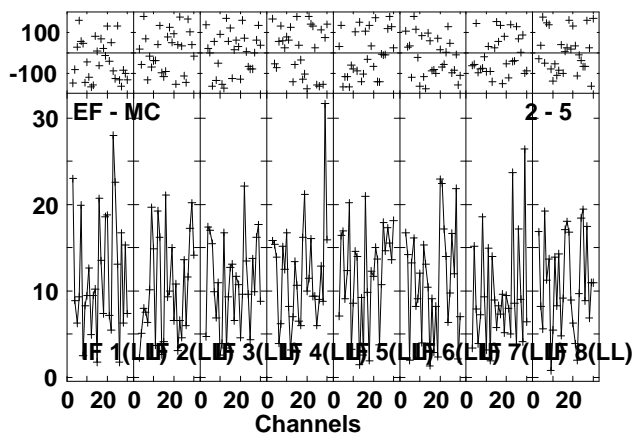
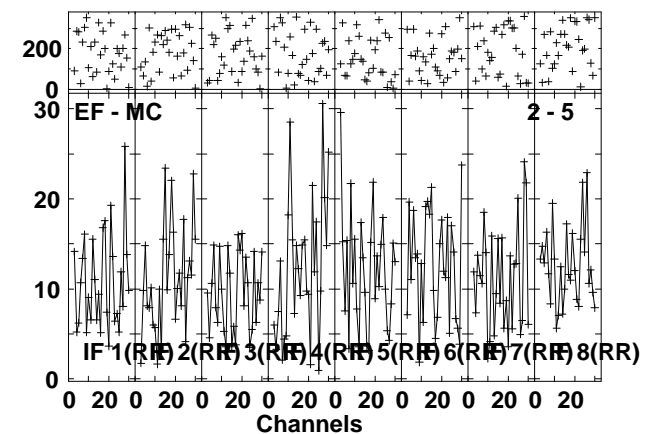
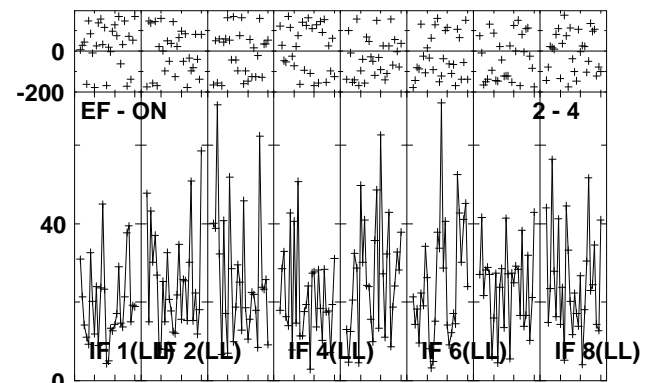
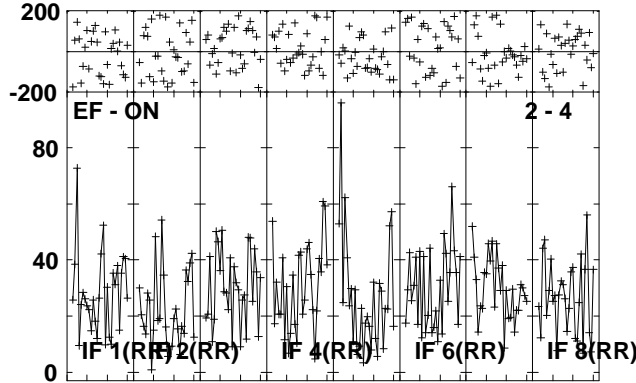
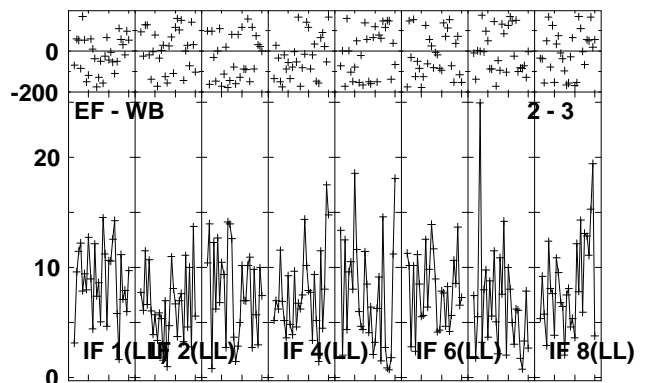
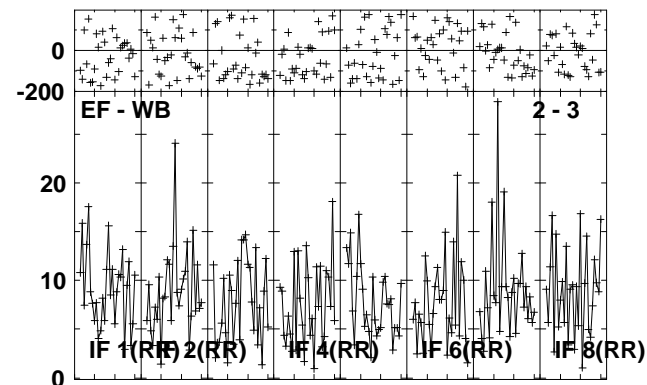
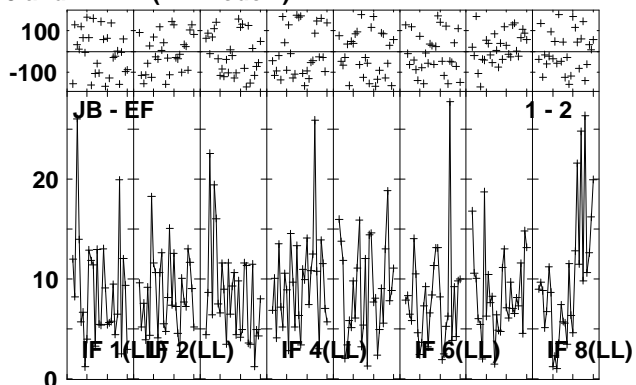
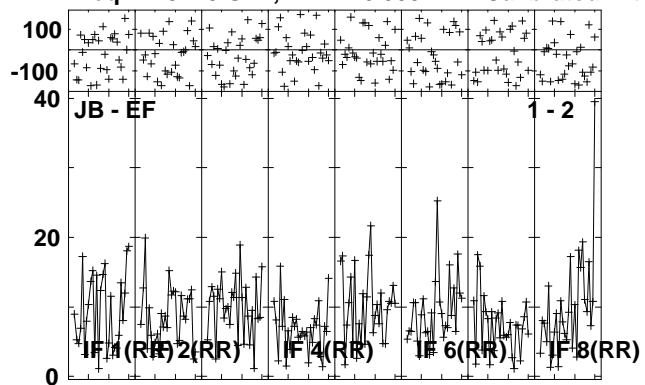

Lower frame: Milli Ampl Jy Top frame: Phas deg  
Vector averaged cross-power spectrum Several baselines displayed  
Timerange: 01/00:29:31 to 01/00:32:59

Plot file version 98 created 24-AUG-2010 08:18:51

IRAS1929 EP064M.UVDATA.1

Freq = 4.9270 GHz, Bw = 16.000 MH Calibrated with CL # 3 and BP # 1 (BP mode 1)

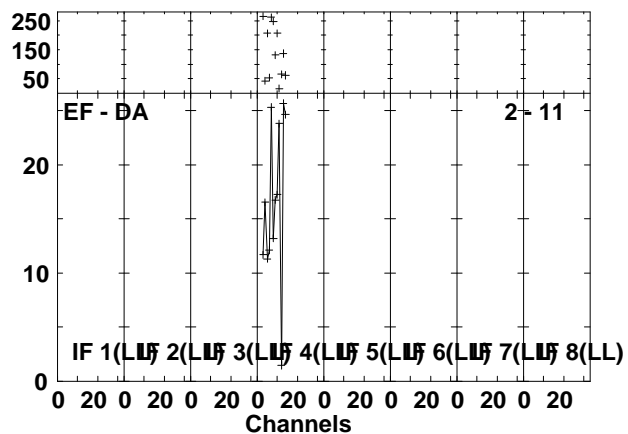
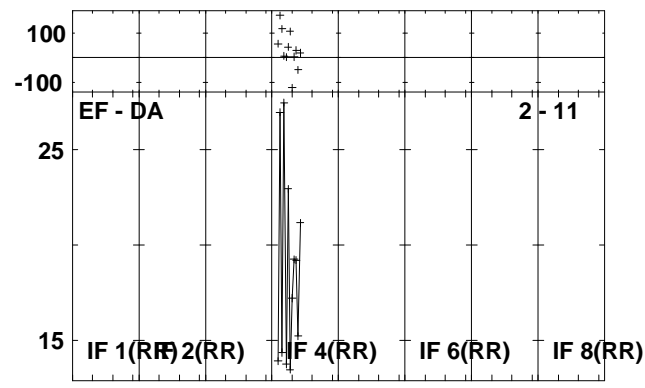
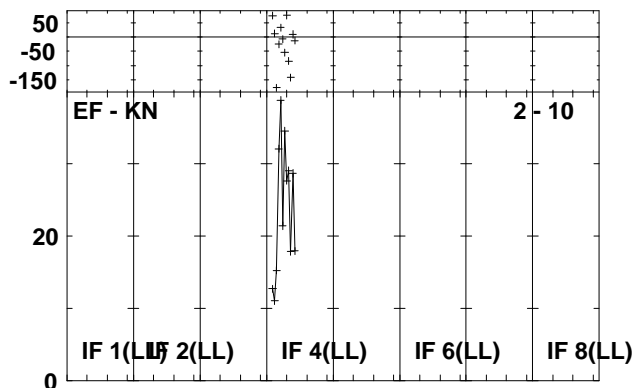
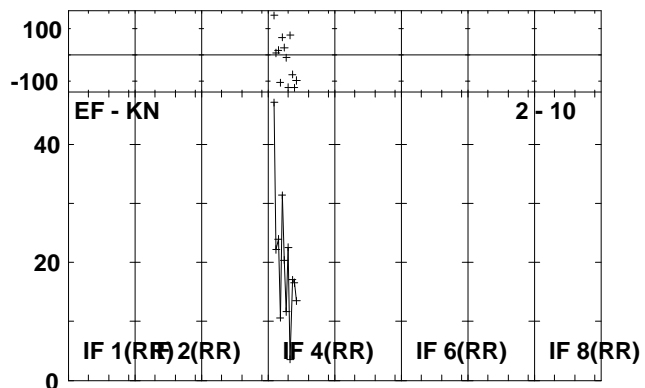
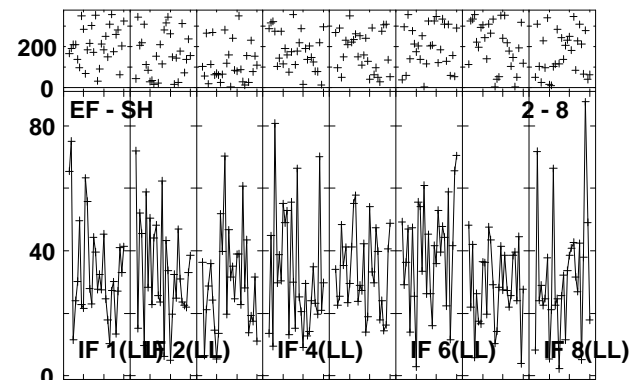
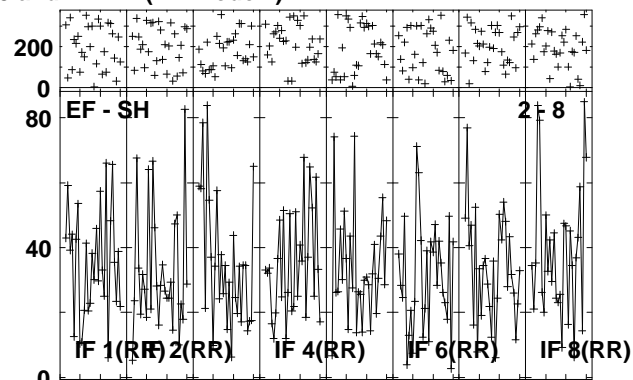
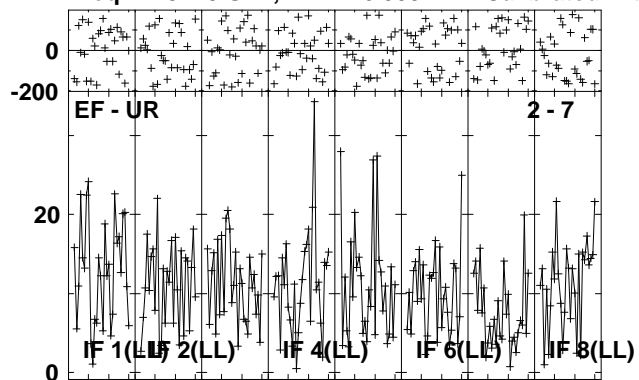

Lower frame: Milli Ampl Jy Top frame: Phas deg  
Vector averaged cross-power spectrum Several baselines displayed  
Timerange: 01/00:29:31 to 01/00:32:59