

Plot file version 1 created 15-MAR-2012 17:30:31
 3C345G85 EZ020E 2.UVDATA.1
 Freq = 6.6335 GHz, Bw = 8.000 MH No calibration applied and no bandpass applied

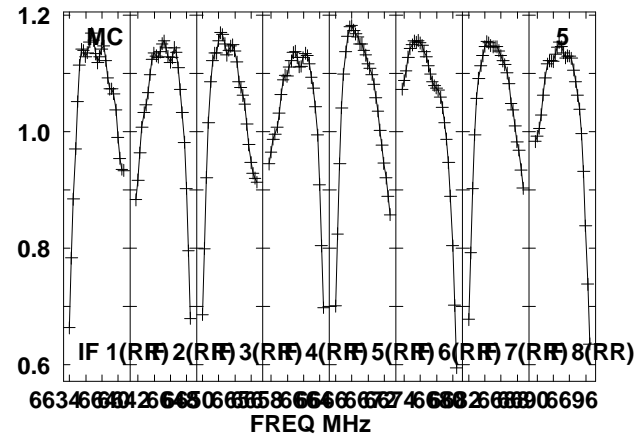
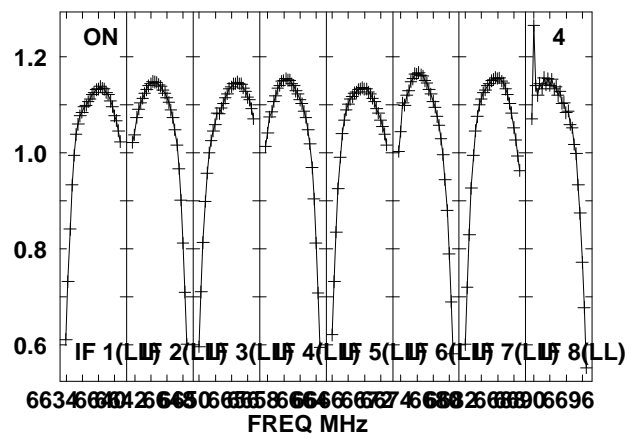
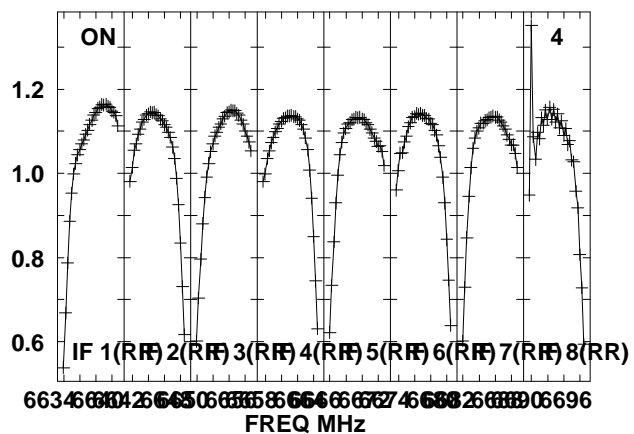
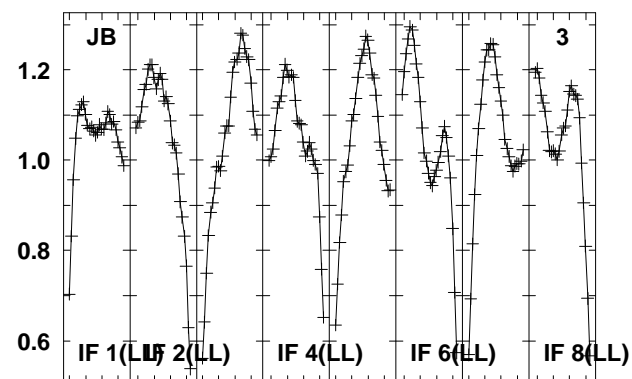
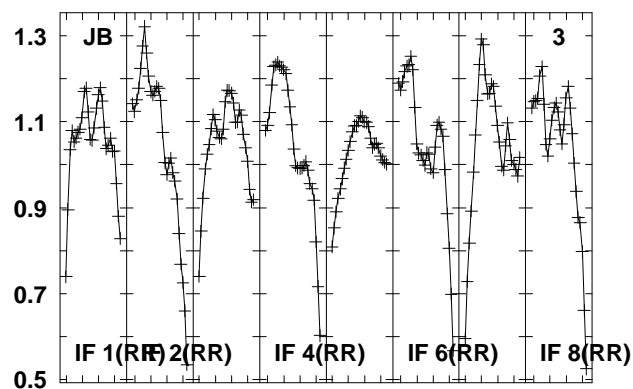
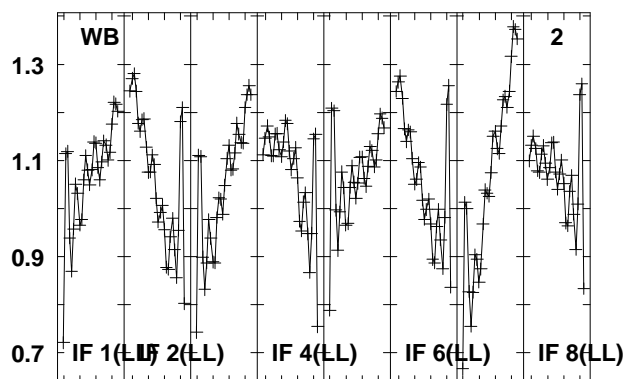
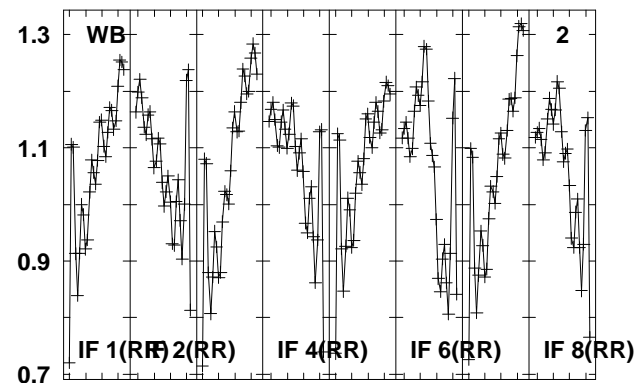
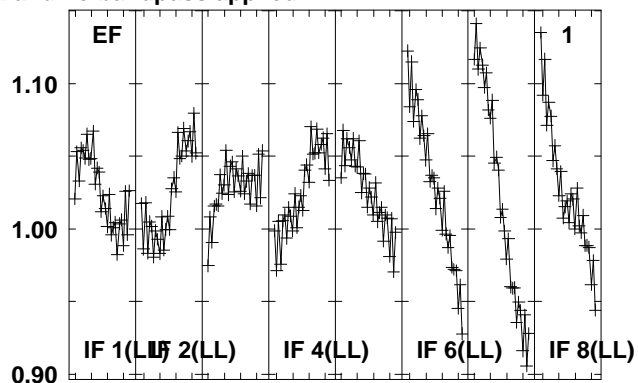
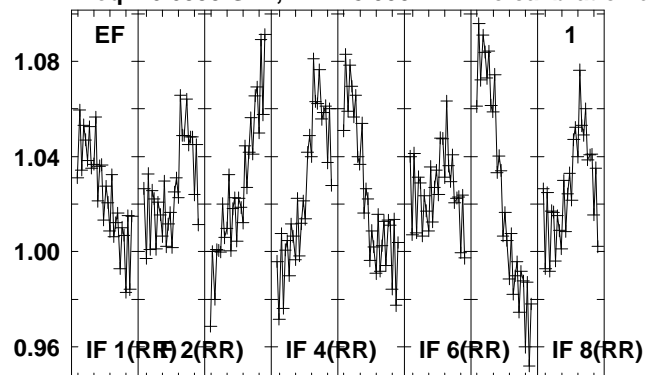

Lower frame: Real Jy
 Total-power spectrum Antenna: *
 Timerange: 00/09:56:45 to 00/09:59:42

Plot file version 2 created 15-MAR-2012 17:30:32

3C345G85 EZ020E 2.UVDATA.1

Freq = 6.6335 GHz, Bw = 8.000 MH No calibration applied and no bandpass applied

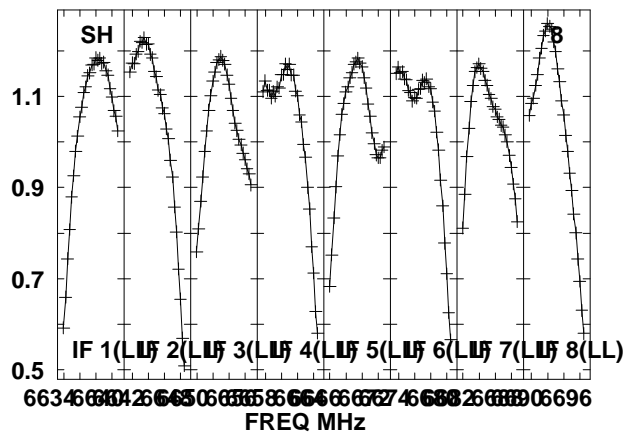
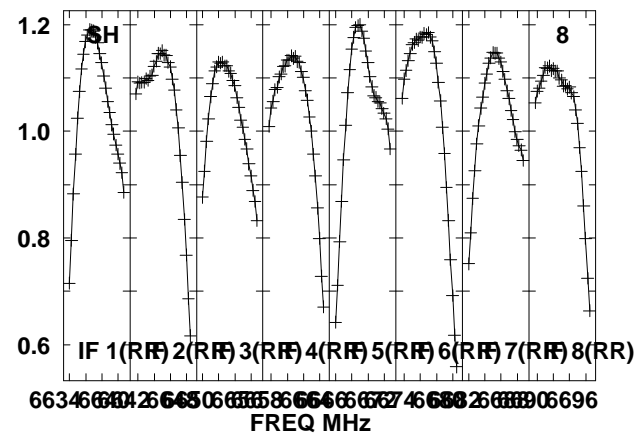
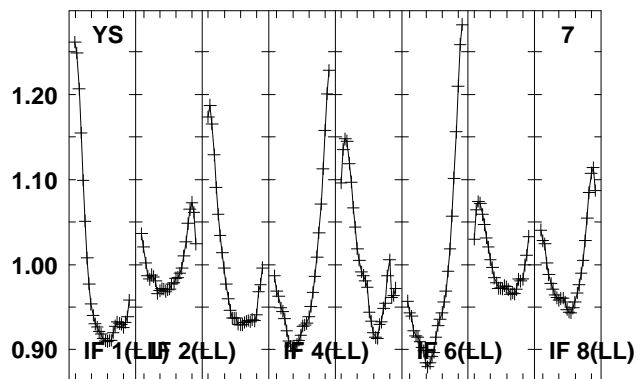
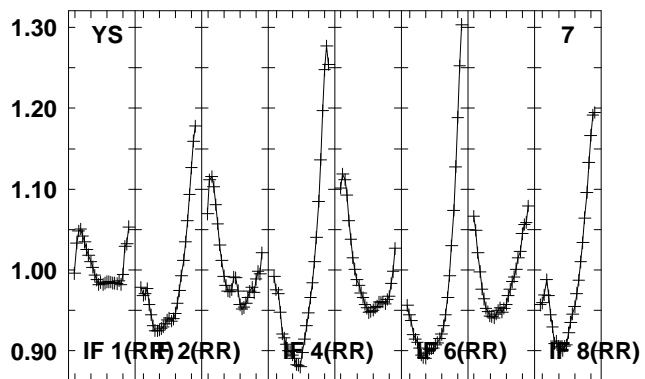
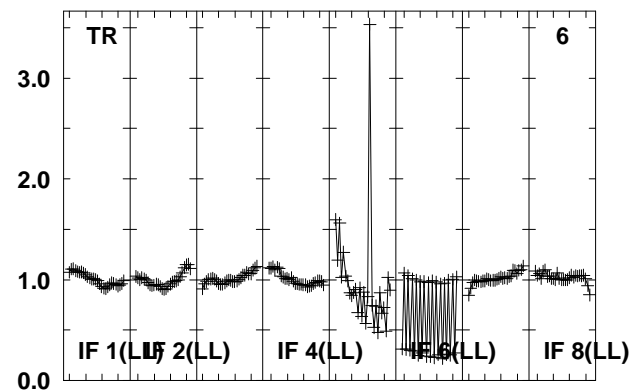
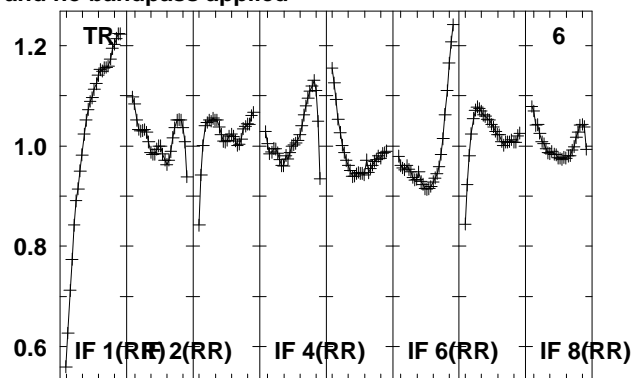
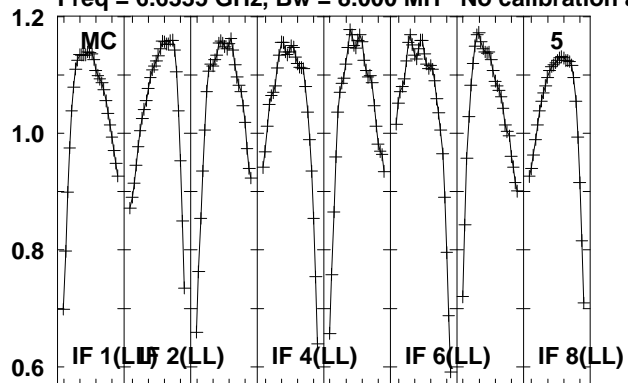

Lower frame: Real Jy

Total-power spectrum Antenna: *

Timerange: 00/09:56:45 to 00/09:59:42

Plot file version 3 created 15-MAR-2012 17:30:33

G85.40 EZ020E 2.UVDATA.1

Freq = 6.6335 GHz, Bw = 8.000 MH No calibration applied and no bandpass applied

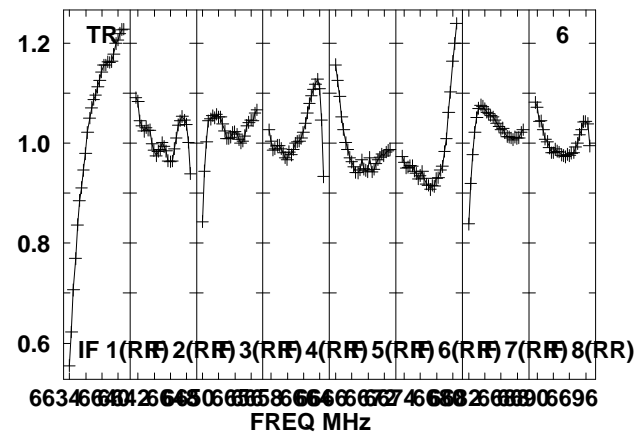
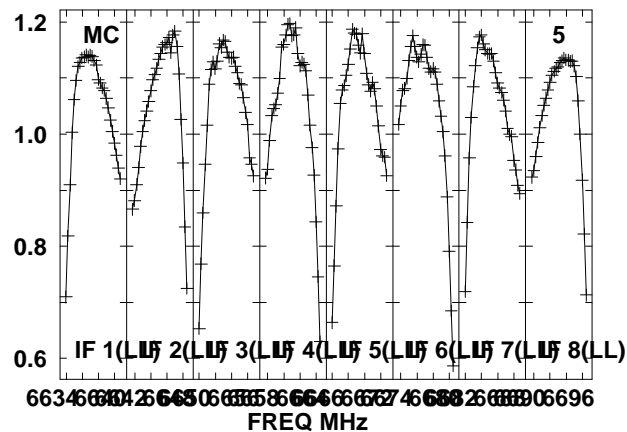
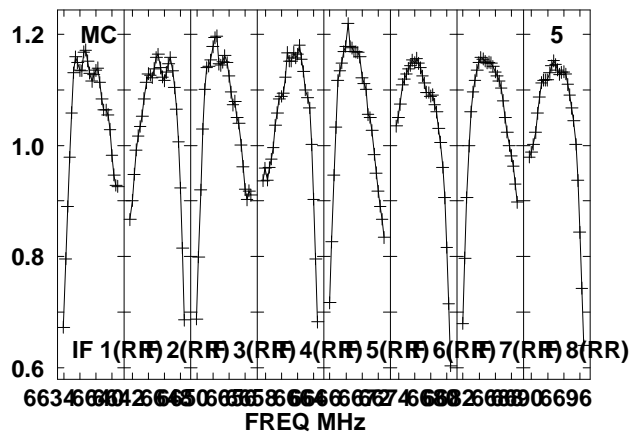
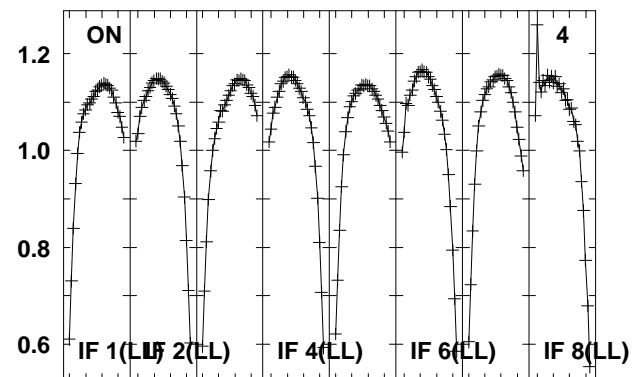
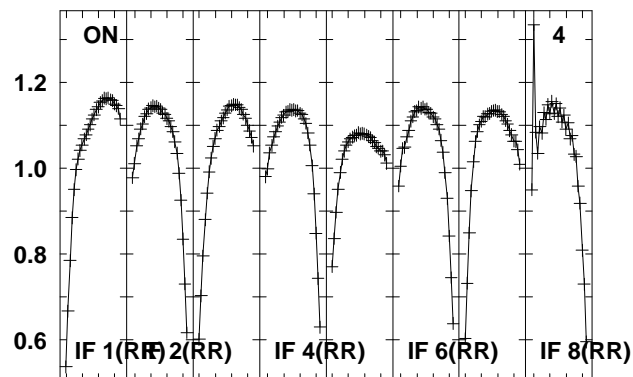
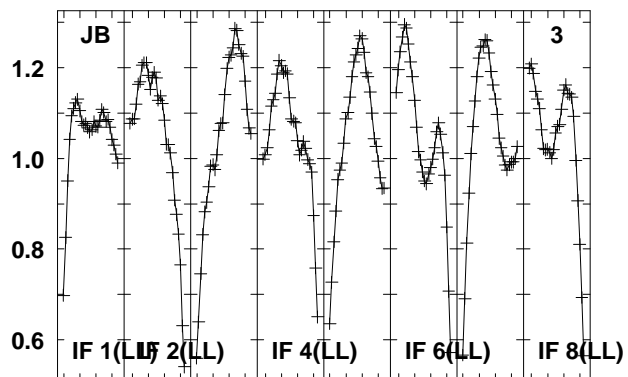
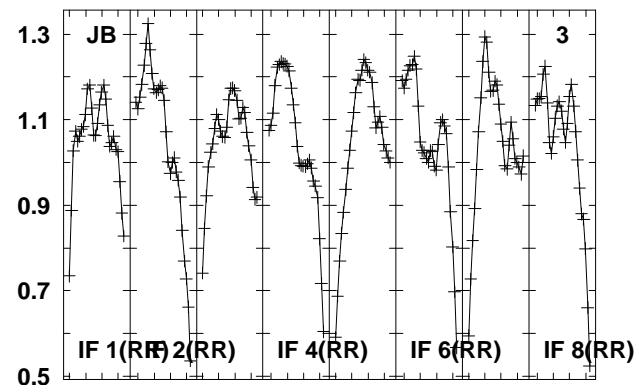
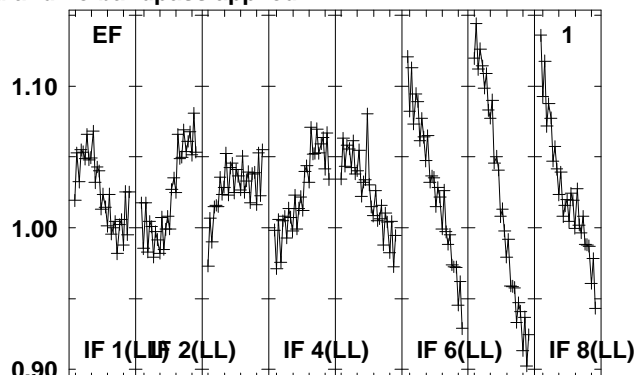
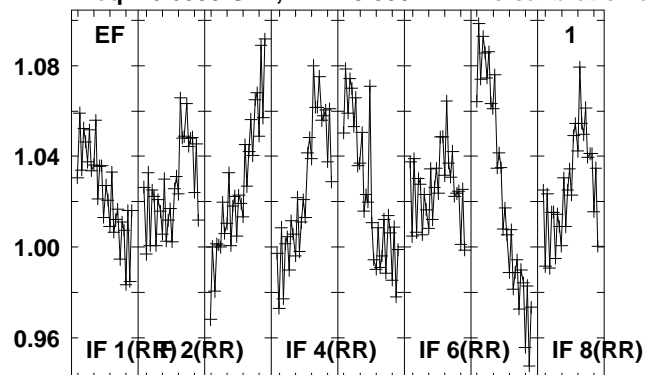

Lower frame: Real Jy
Total-power spectrum Antenna: *
Timerange: 00/10:03:26 to 00/10:04:23

Plot file version 4 created 15-MAR-2012 17:30:33

G85.40 EZ020E 2.UVDATA.1

Freq = 6.6335 GHz, Bw = 8.000 MH No calibration applied and no bandpass applied

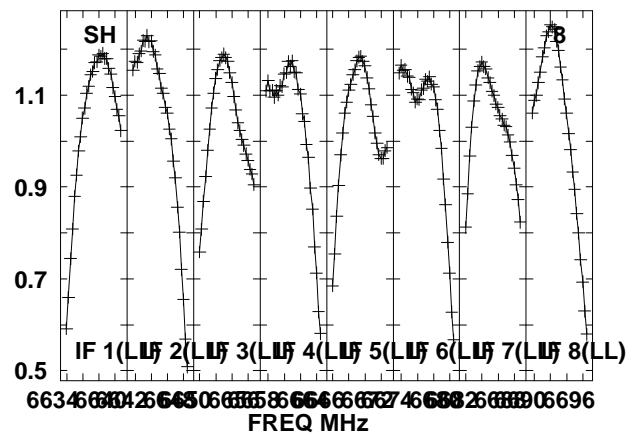
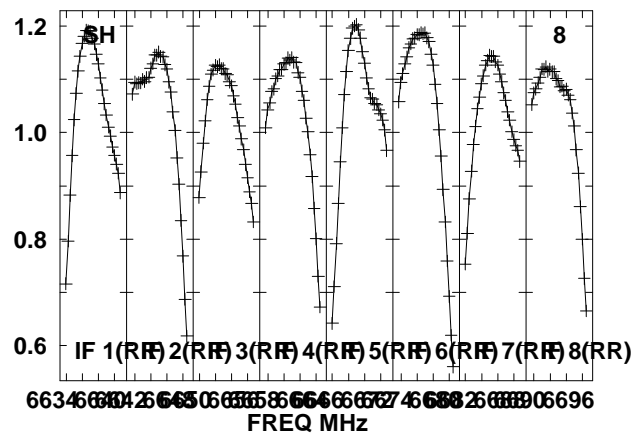
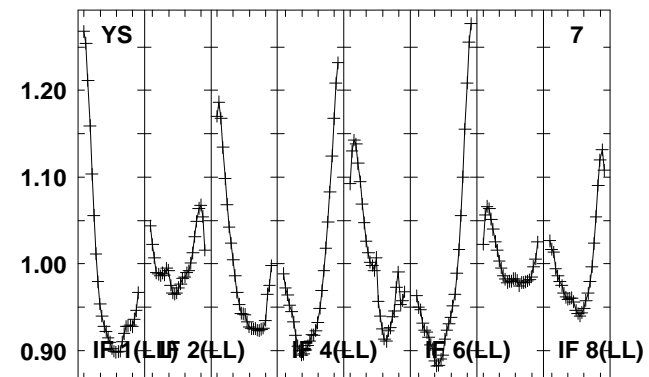
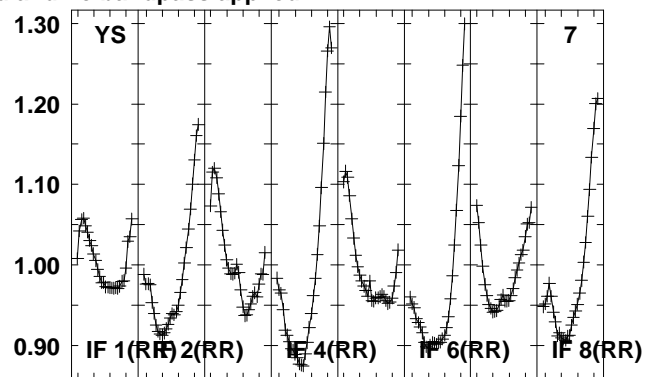
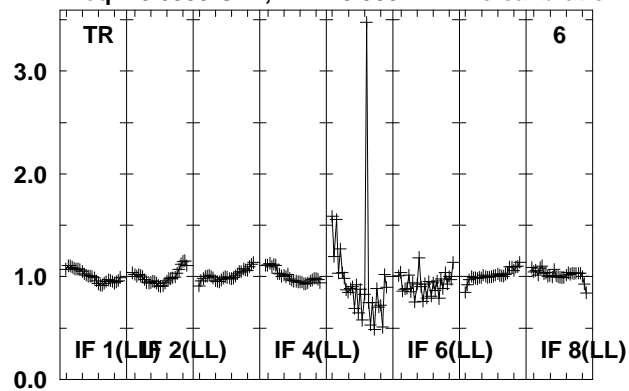

Lower frame: Real Jy
Total-power spectrum Antenna: *
Timerange: 00/10:03:26 to 00/10:04:23

Plot file version 5 created 15-MAR-2012 17:30:34
 2102-G85 EZ020E 2.UVDATA.1
 Freq = 6.6335 GHz, Bw = 8.000 MH No calibration applied and no bandpass applied

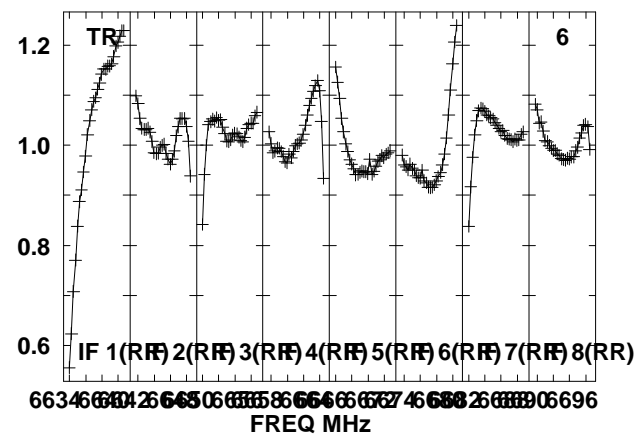
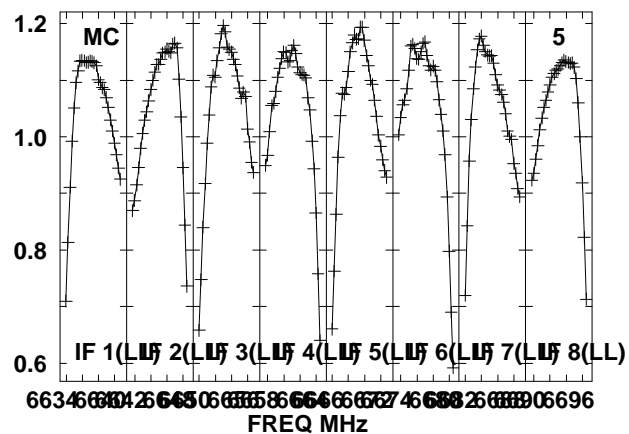
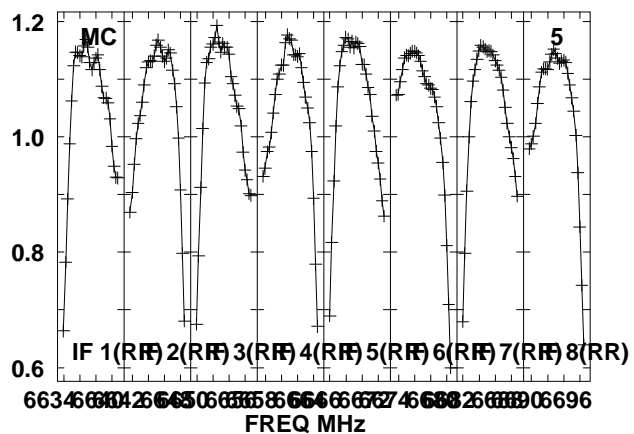
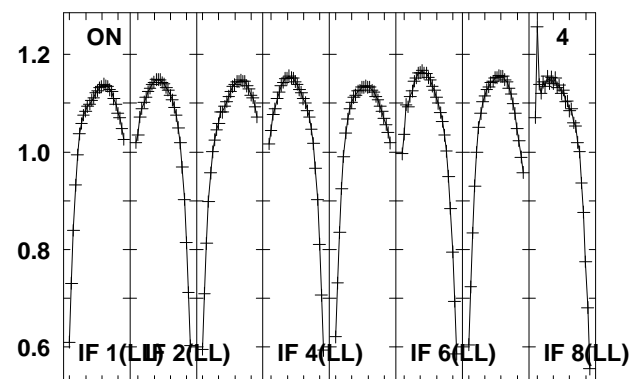
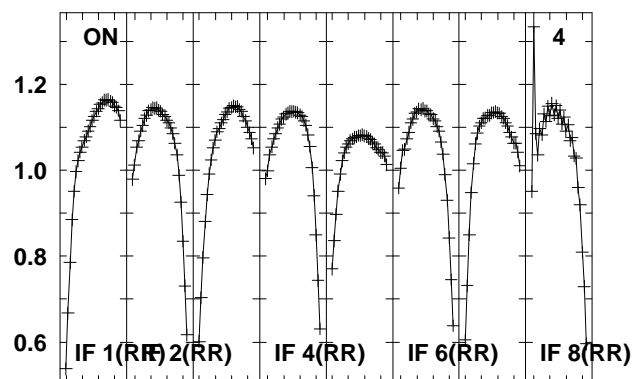
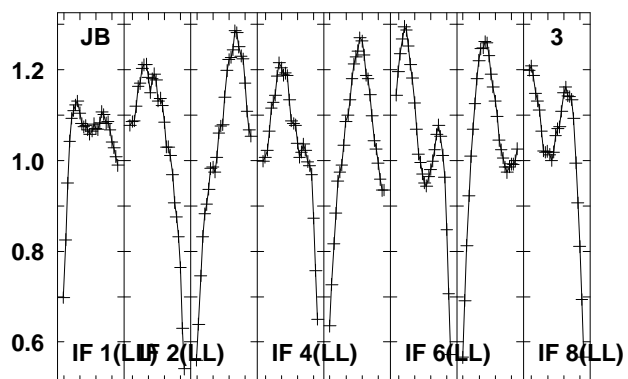
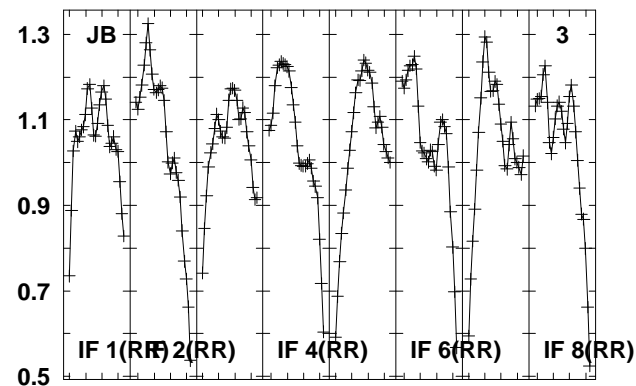
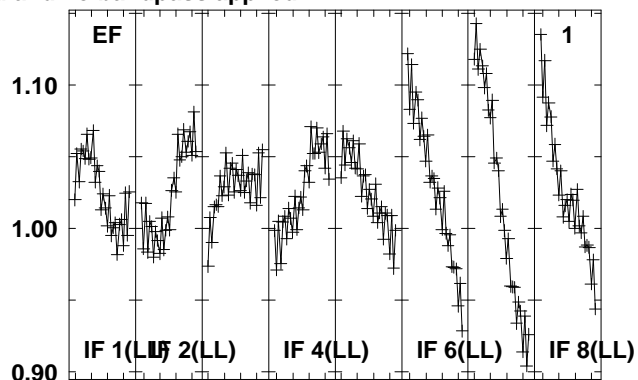
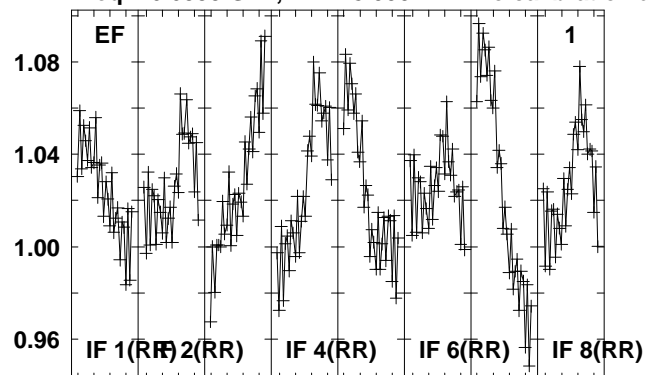

Lower frame: Real Jy
 Total-power spectrum Antenna: *
 Timerange: 00/10:04:25 to 00/10:05:53

Plot file version 6 created 15-MAR-2012 17:30:34

2102-G85 EZ020E 2.UVDATA.1

Freq = 6.6335 GHz, Bw = 8.000 MH No calibration applied and no bandpass applied

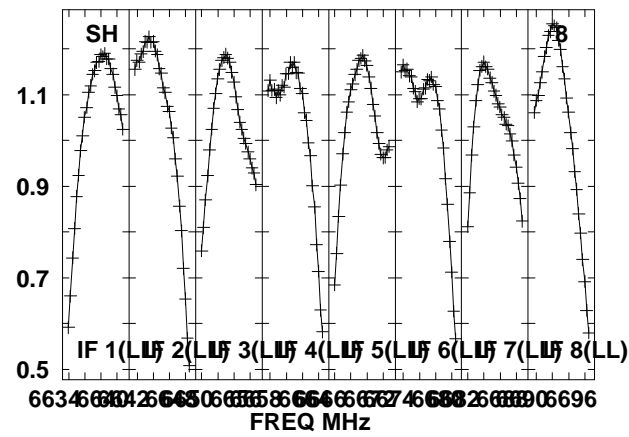
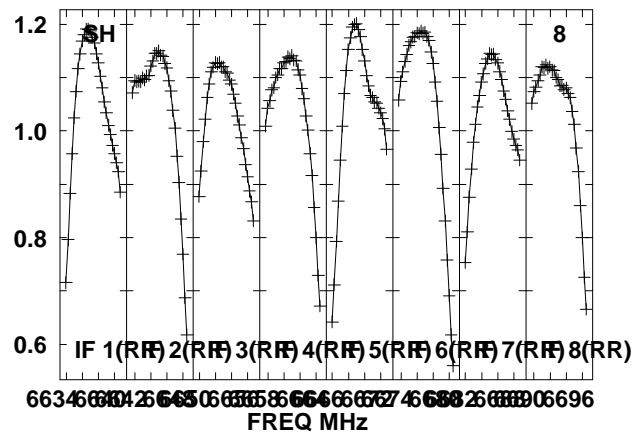
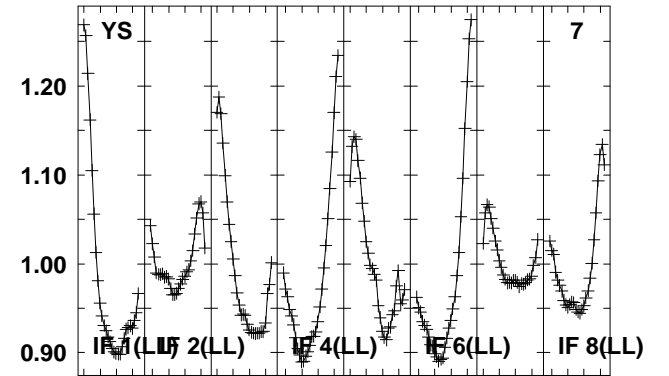
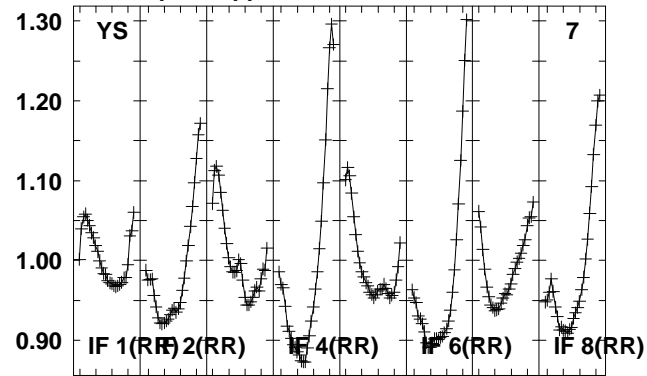
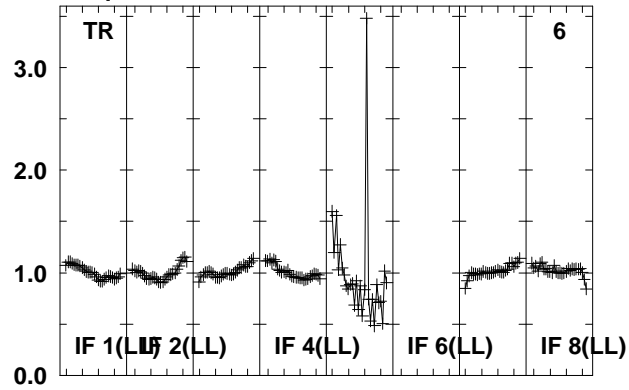

Lower frame: Real Jy
Total-power spectrum Antenna: *
Timerange: 00/10:04:25 to 00/10:05:53

Plot file version 7 created 15-MAR-2012 17:30:35
 G85.40 EZ020E 2.UVDATA.1
 Freq = 6.6335 GHz, Bw = 8.000 MH No calibration applied and no bandpass applied

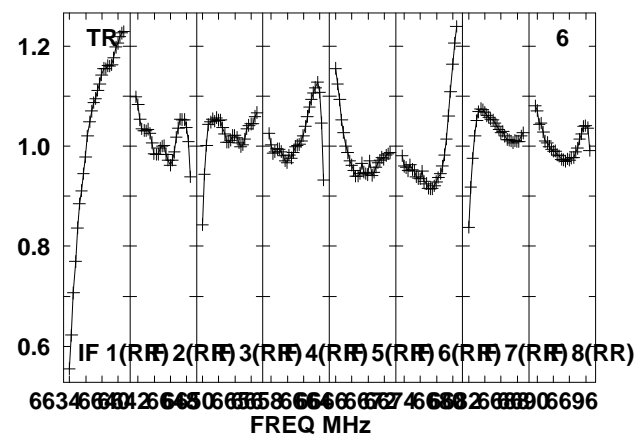
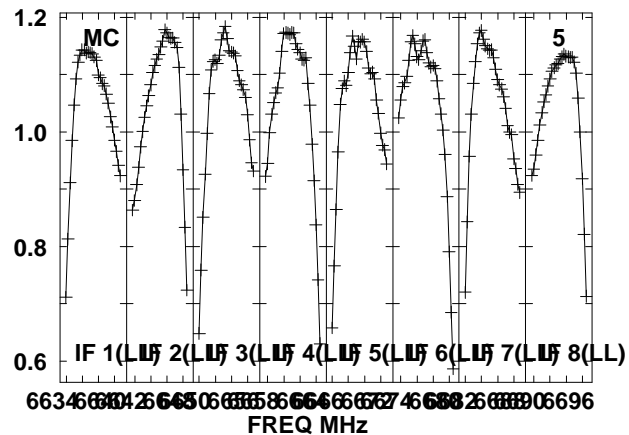
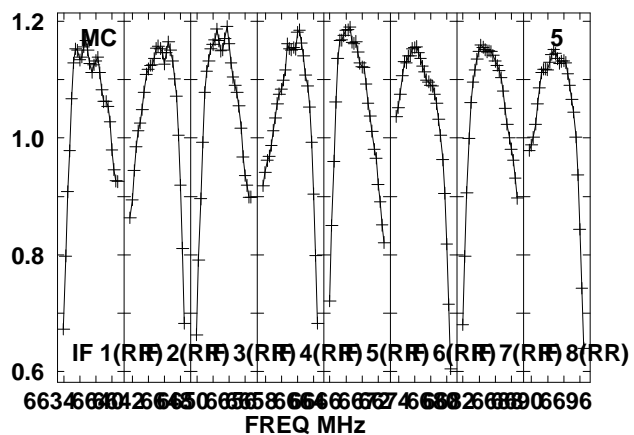
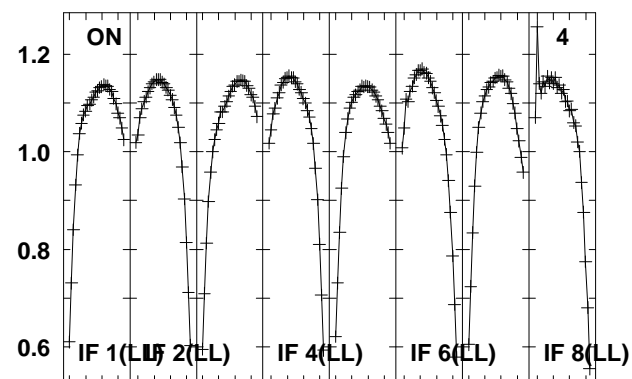
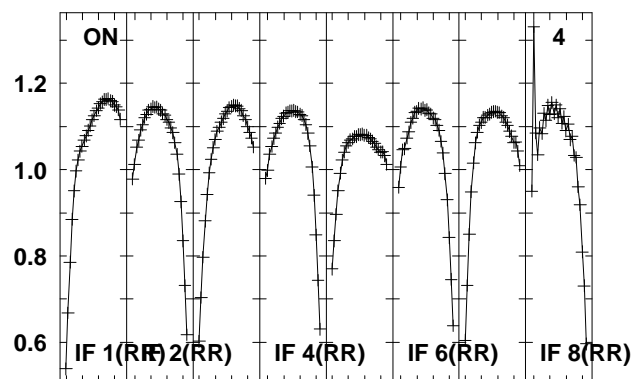
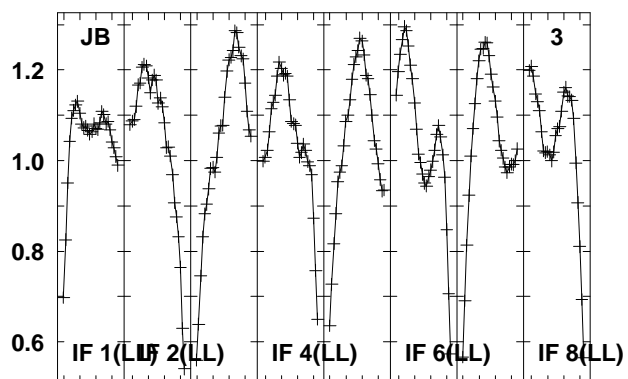
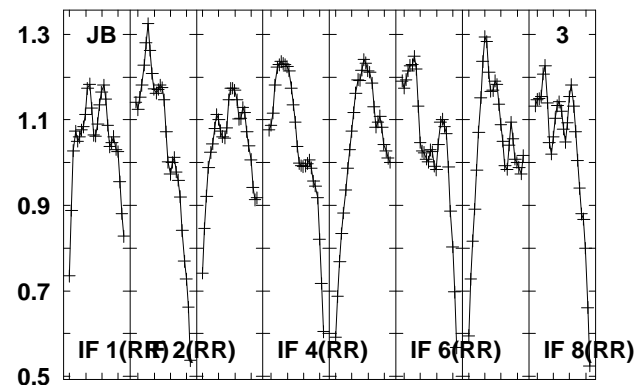
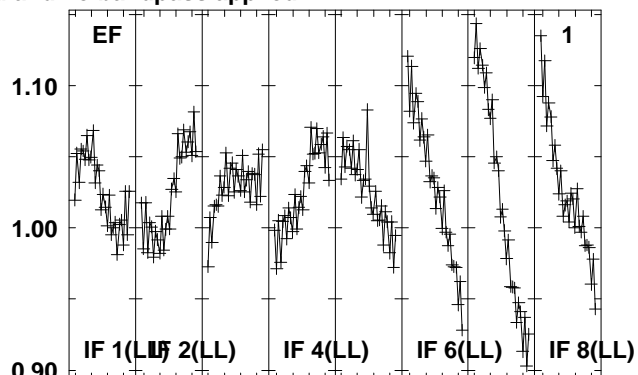
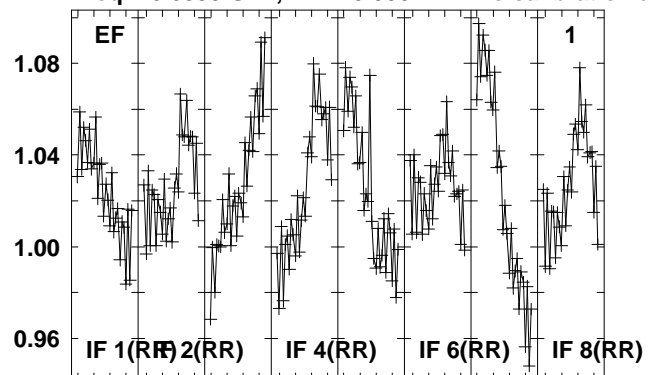

Lower frame: Real Jy
 Total-power spectrum Antenna: *
 Timerange: 00/10:05:56 to 00/10:07:24

Plot file version 8 created 15-MAR-2012 17:30:35

G85.40 EZ020E 2.UVDATA.1

Freq = 6.6335 GHz, Bw = 8.000 MH No calibration applied and no bandpass applied

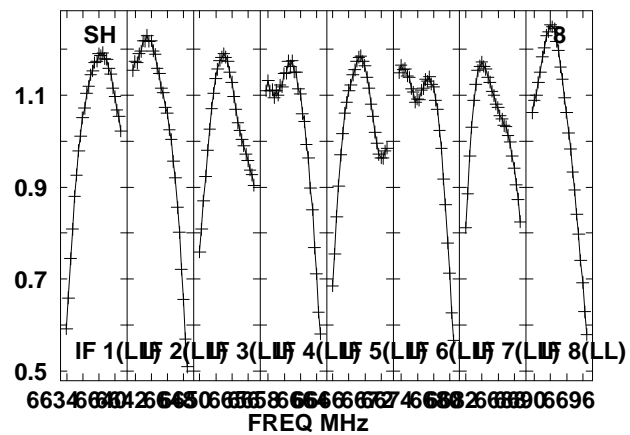
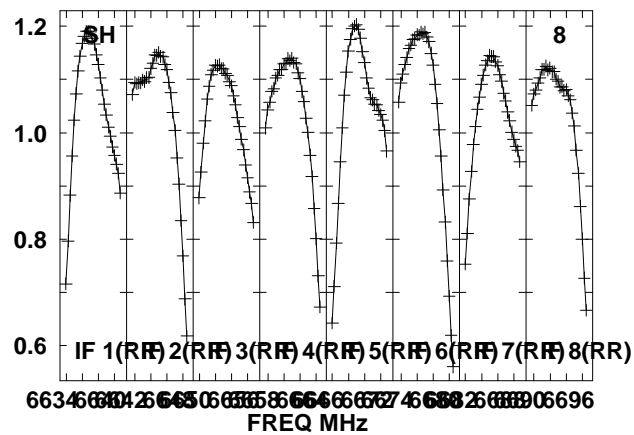
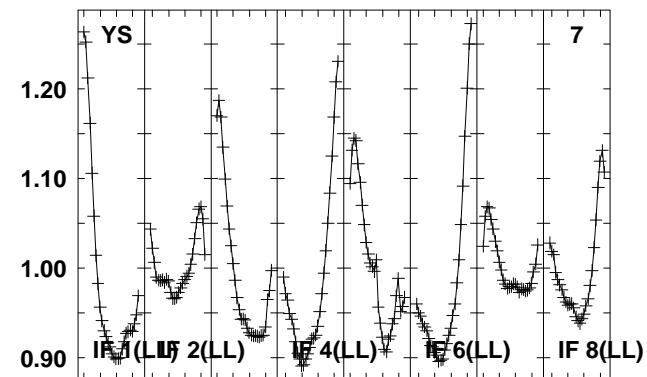
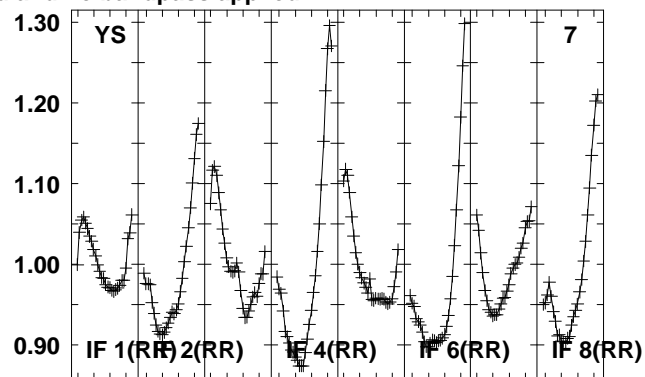
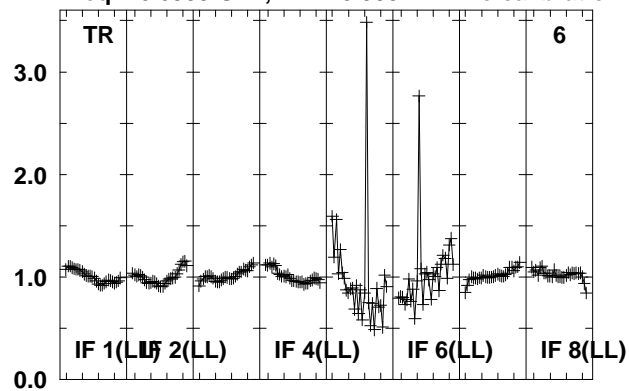

Lower frame: Real Jy
Total-power spectrum Antenna: *
Timerange: 00/10:05:56 to 00/10:07:24

Plot file version 9 created 15-MAR-2012 17:30:36

2114-G85 EZ020E 2.UVDATA.1

Freq = 6.6335 GHz, Bw = 8.000 MH No calibration applied and no bandpass applied

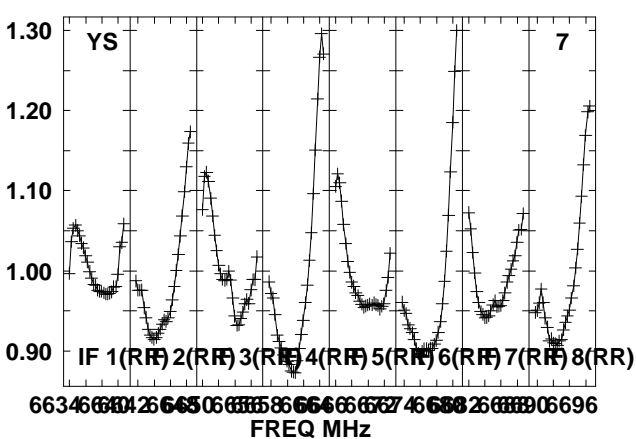
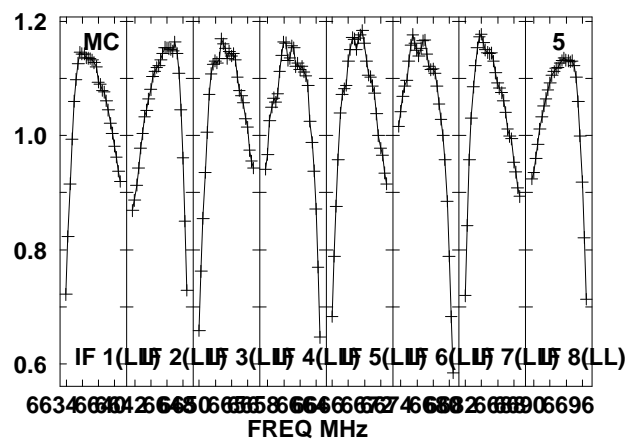
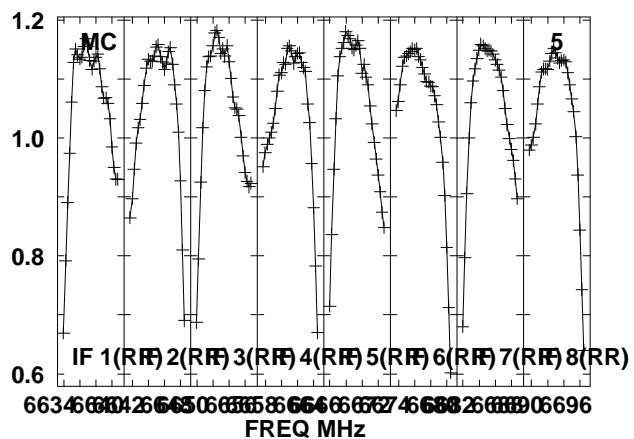
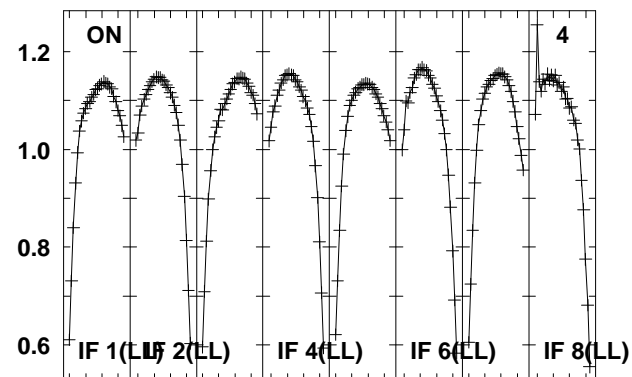
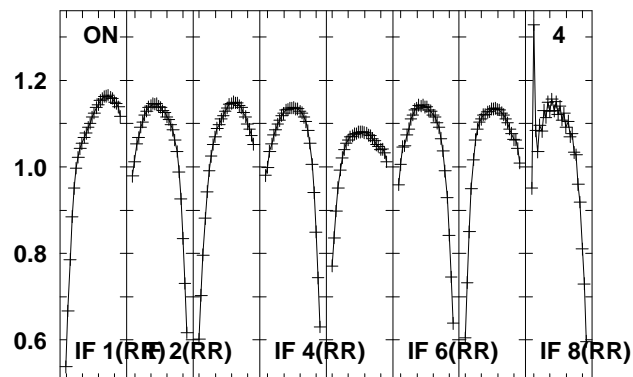
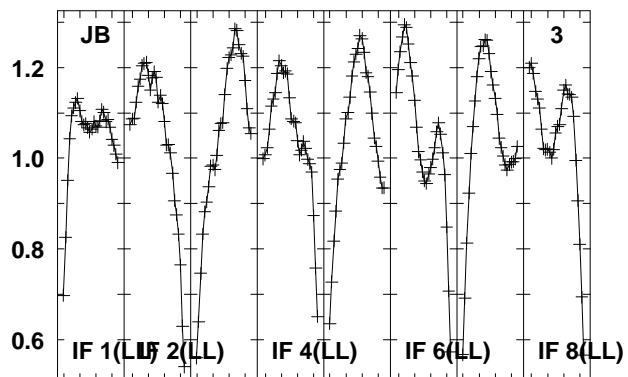
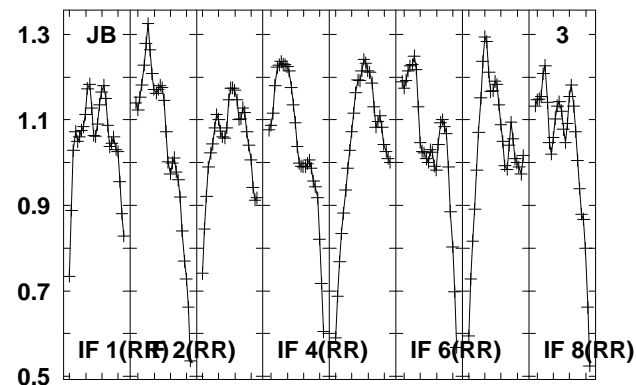
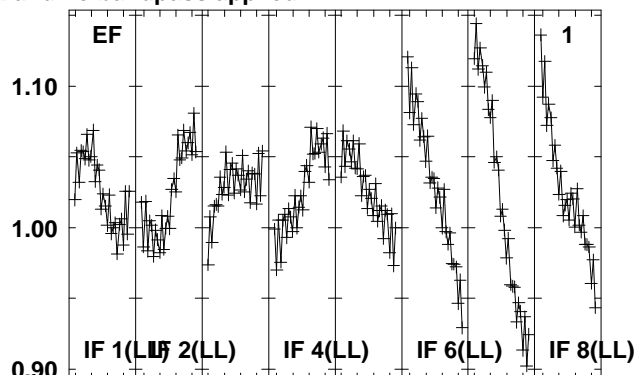
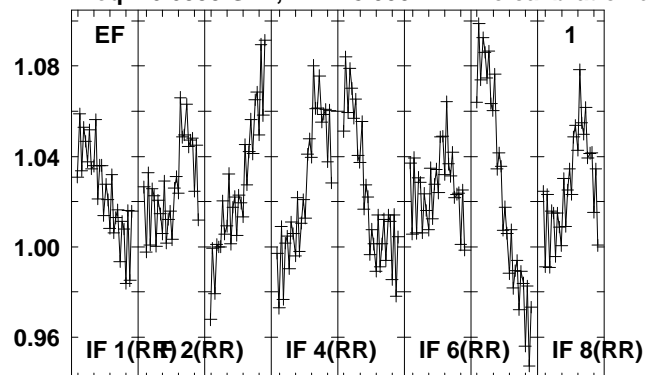

Lower frame: Real Jy
Total-power spectrum Antenna: *
Timerange: 00/10:07:25 to 00/10:08:53

Plot file version 10 created 15-MAR-2012 17:30:36

2114-G85 EZ020E 2.UVDATA.1

Freq = 6.6335 GHz, Bw = 8.000 MH No calibration applied and no bandpass applied

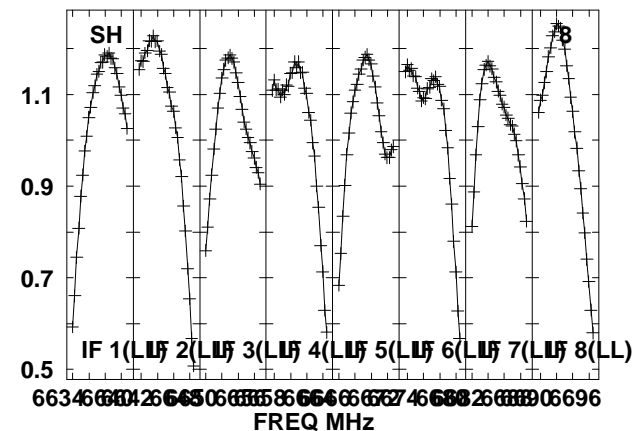
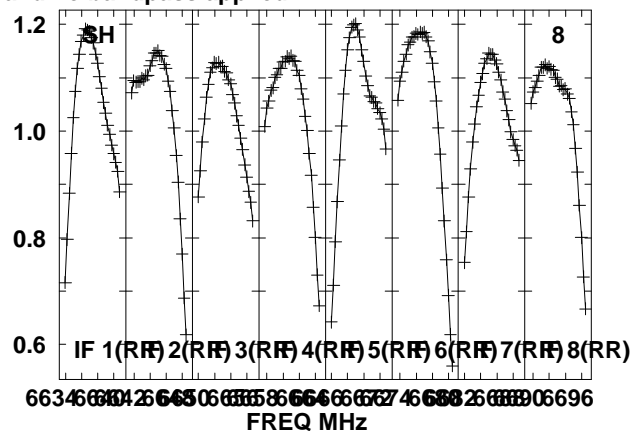
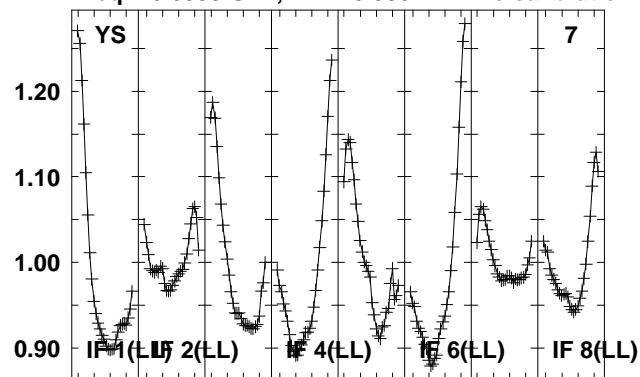

Lower frame: Real Jy
Total-power spectrum Antenna: *
Timerange: 00/10:07:25 to 00/10:08:53

Plot file version 11 created 15-MAR-2012 17:30:37

G85.40 EZ020E 2.UVDATA.1

Freq = 6.6335 GHz, Bw = 8.000 MH No calibration applied and no bandpass applied

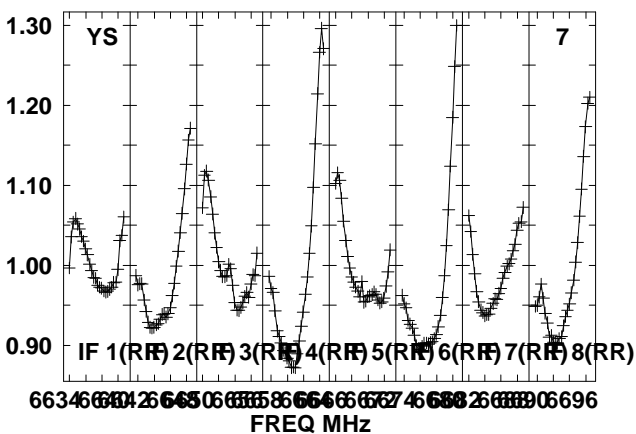
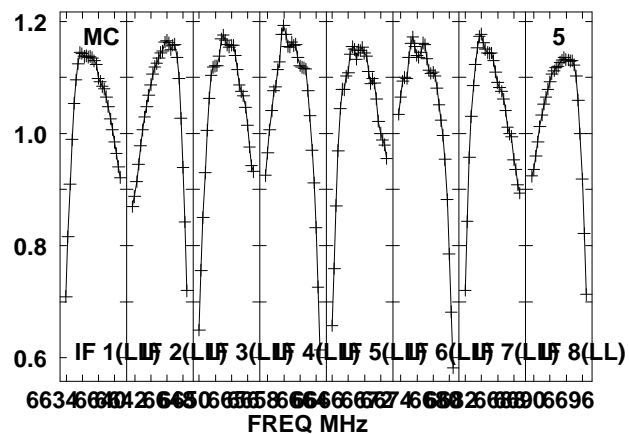
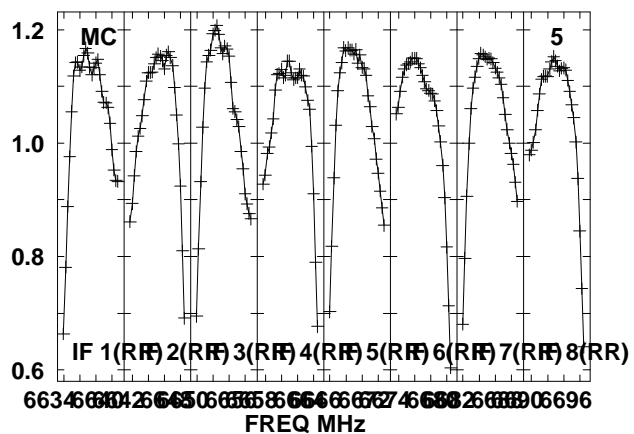
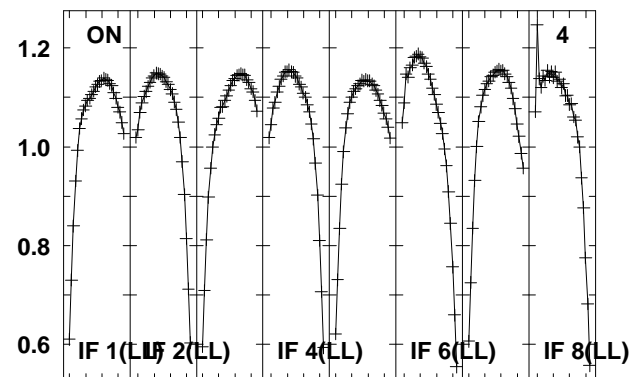
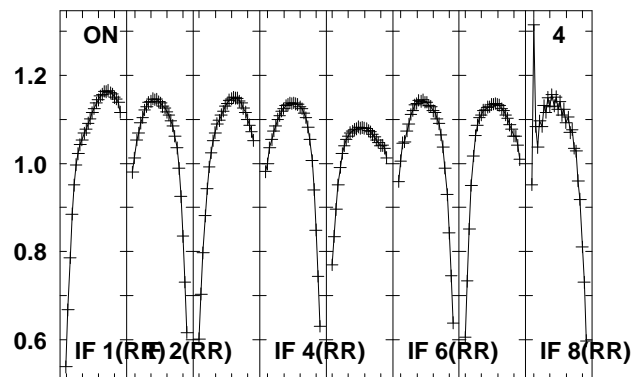
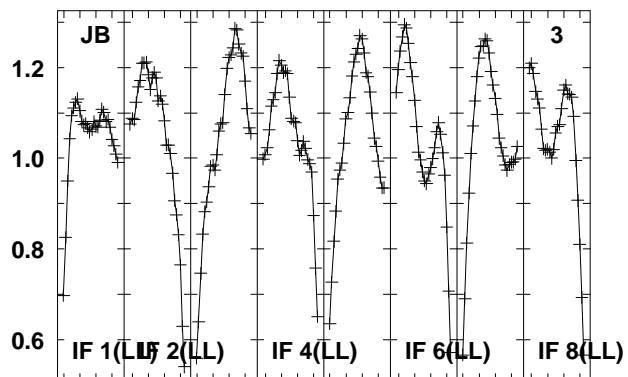
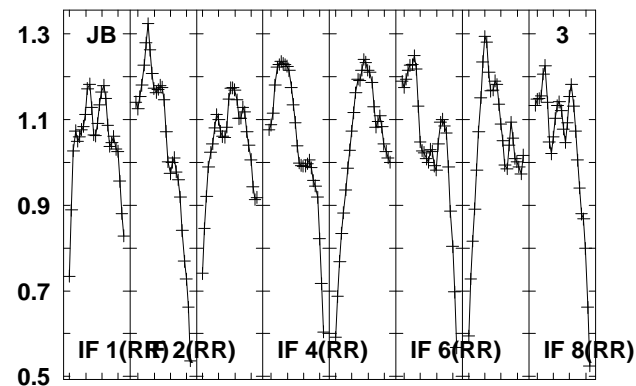
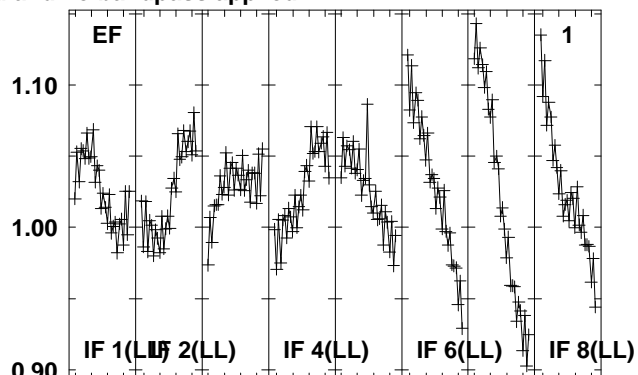
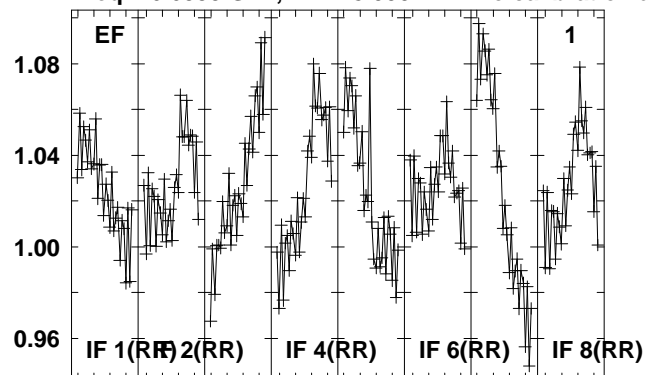

Lower frame: Real Jy
Total-power spectrum Antenna: *
Timerange: 00/10:08:56 to 00/10:10:24

Plot file version 12 created 15-MAR-2012 17:30:37

G85.40 EZ020E 2.UVDATA.1

Freq = 6.6335 GHz, Bw = 8.000 MH No calibration applied and no bandpass applied

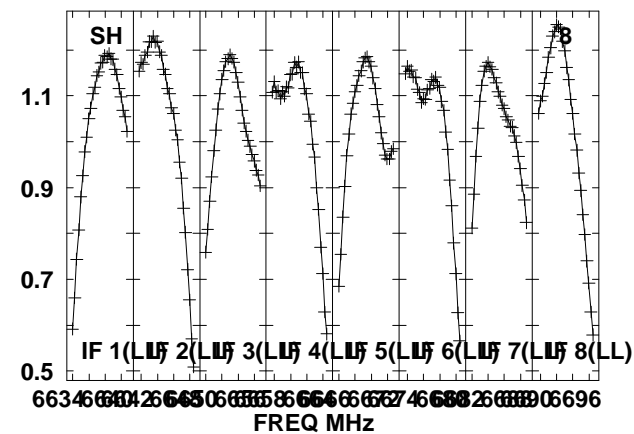
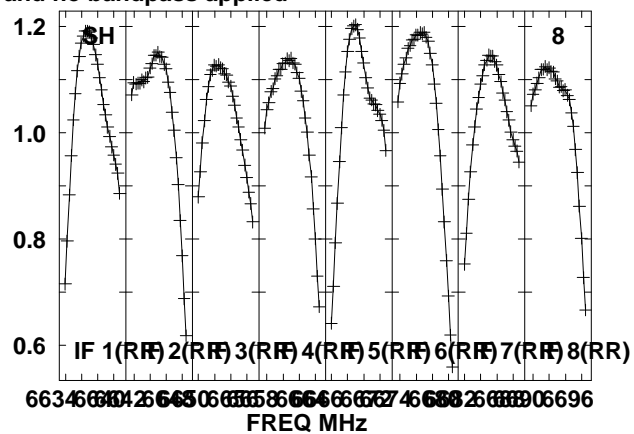
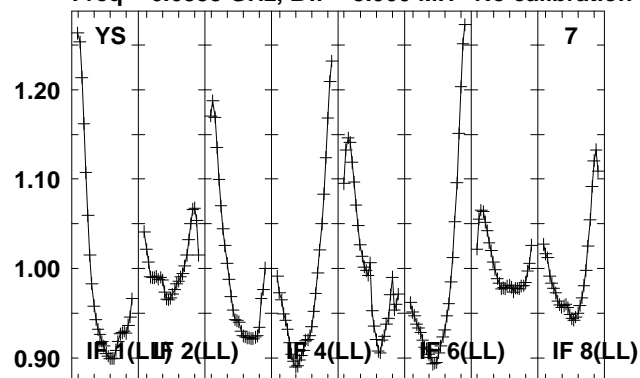

Lower frame: Real Jy
Total-power spectrum Antenna: *
Timerange: 00/10/08:56 to 00/10/10:24

Plot file version 13 created 15-MAR-2012 17:30:38
 2102-G85 EZ020E 2.UVDATA.1
 Freq = 6.6335 GHz, Bw = 8.000 MH No calibration applied and no bandpass applied

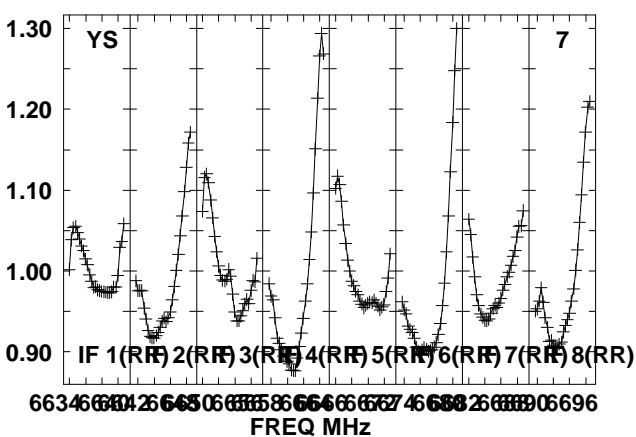
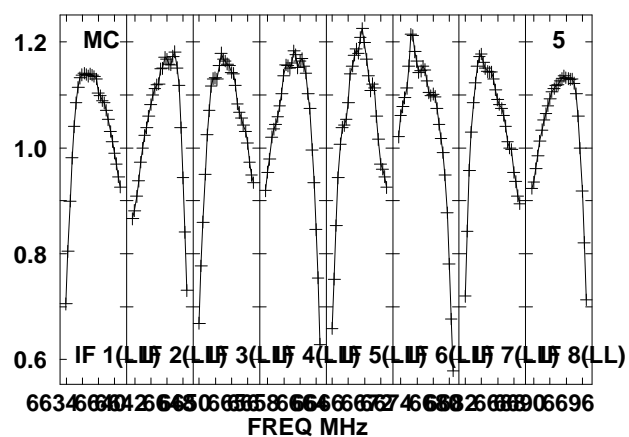
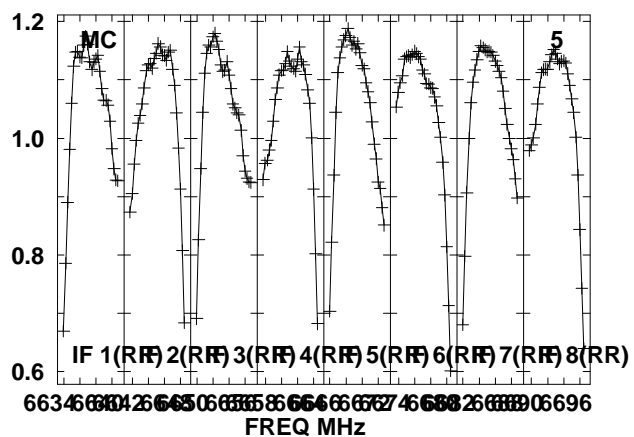
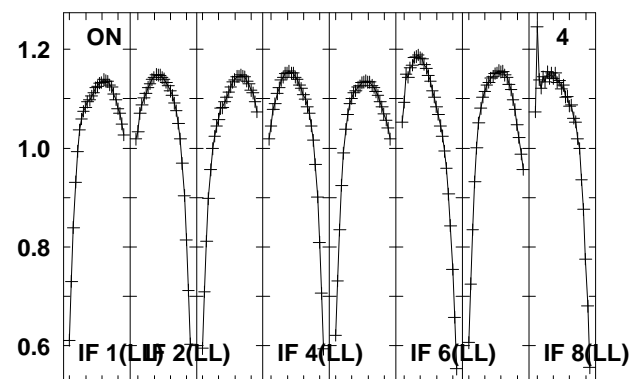
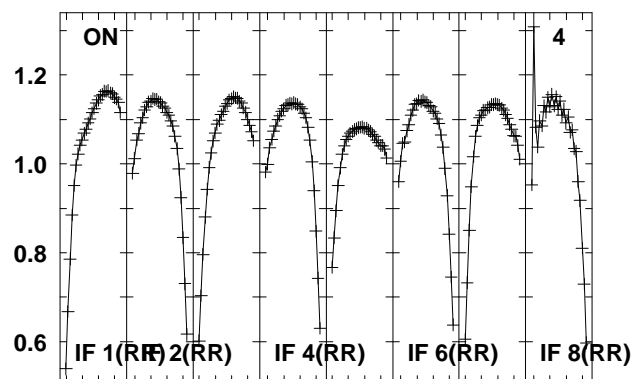
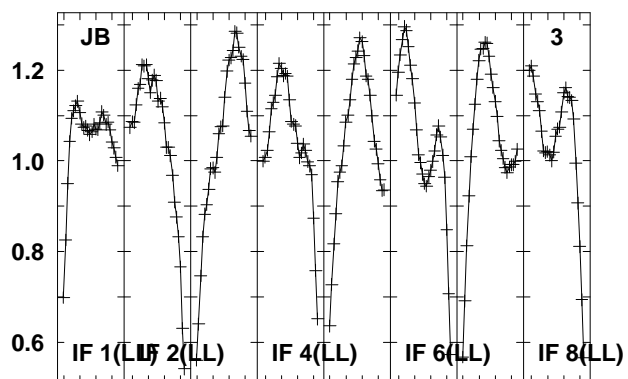
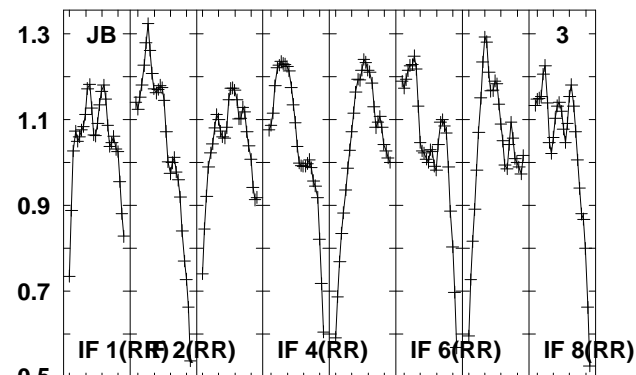
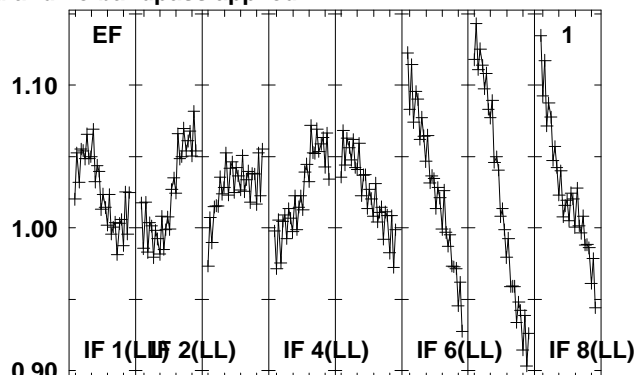
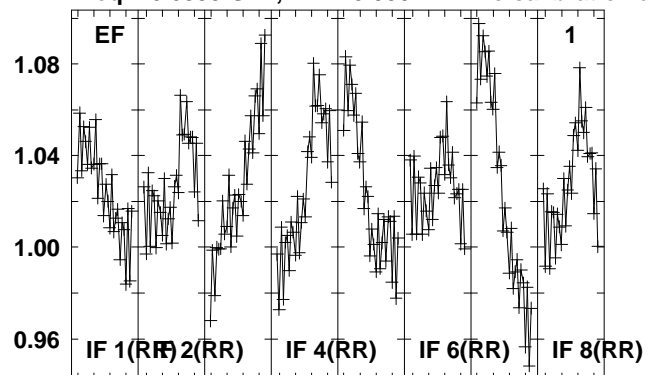

Lower frame: Real Jy
 Total-power spectrum Antenna: *
 Timerange: 00/10:10:25 to 00/10:11:53

Plot file version 14 created 15-MAR-2012 17:30:38

2102-G85 EZ020E 2.UVDATA.1

Freq = 6.6335 GHz, Bw = 8.000 MH No calibration applied and no bandpass applied

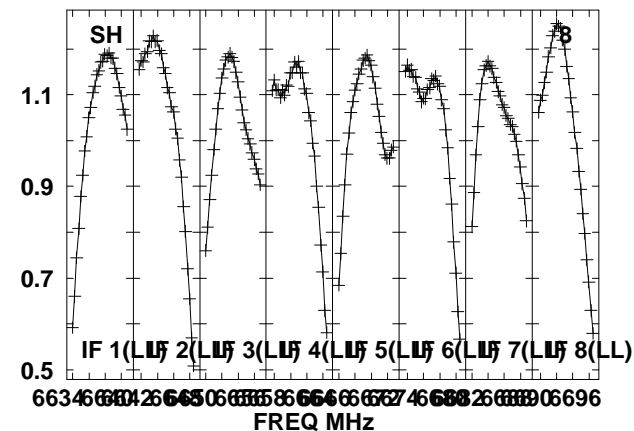
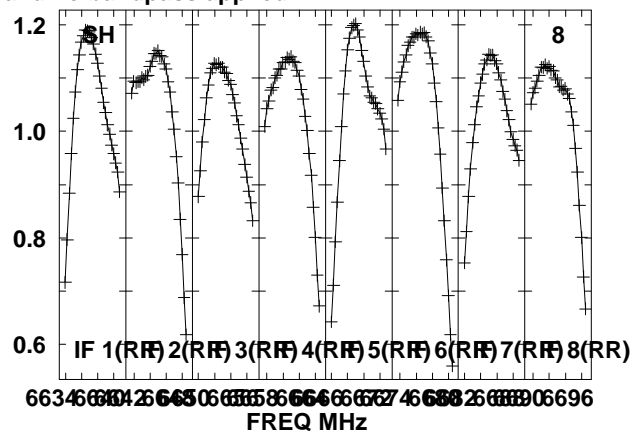
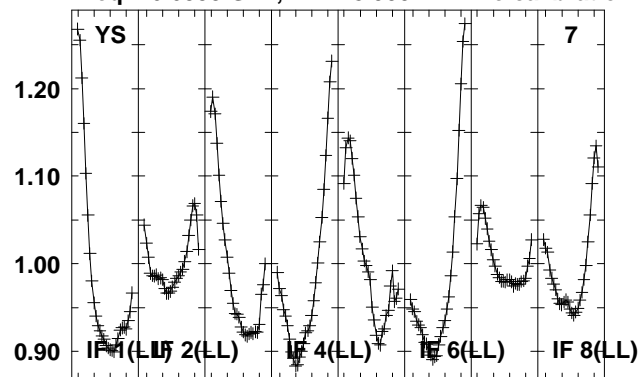

Lower frame: Real Jy
Total-power spectrum Antenna: *
Timerange: 00/10:10:25 to 00/10:11:53

Plot file version 15 created 15-MAR-2012 17:30:39

G85.40 EZ20E 2.UVDATA.1

Freq = 6.6335 GHz, Bw = 8.000 MH No calibration applied and no bandpass applied

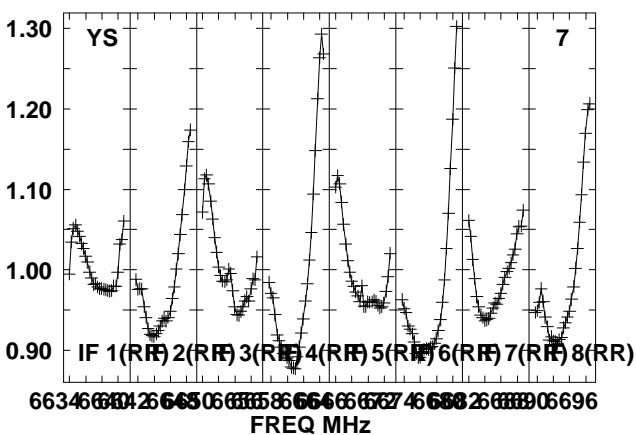
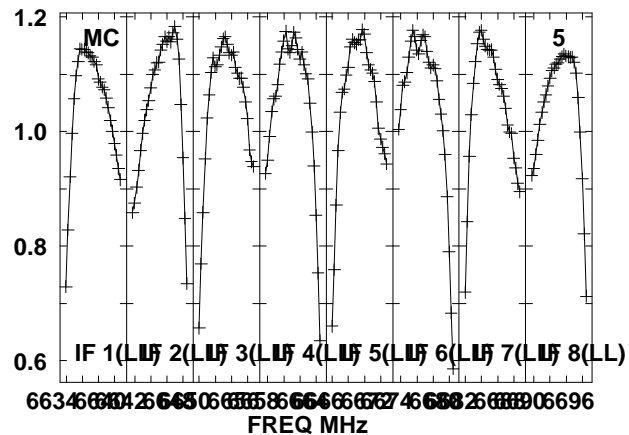
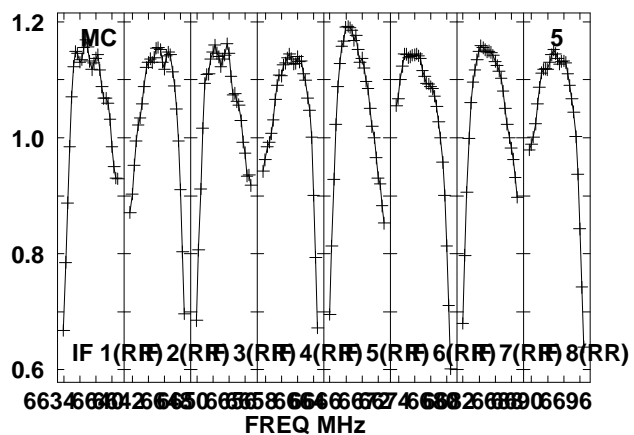
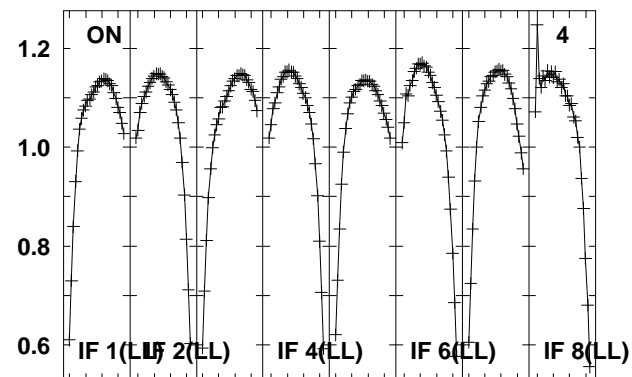
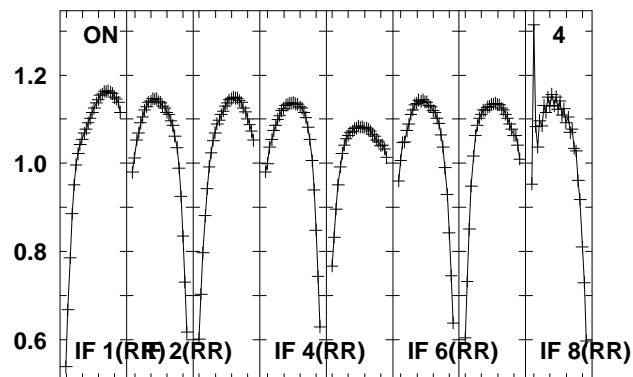
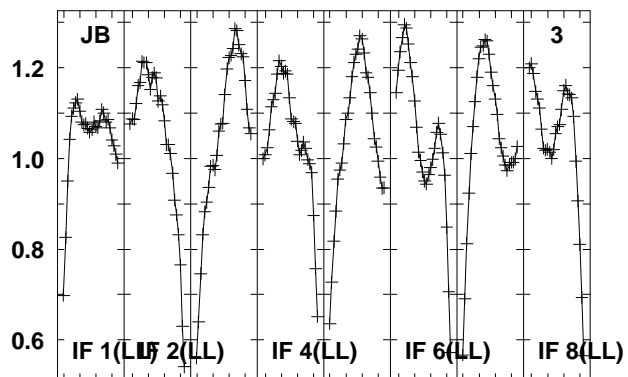
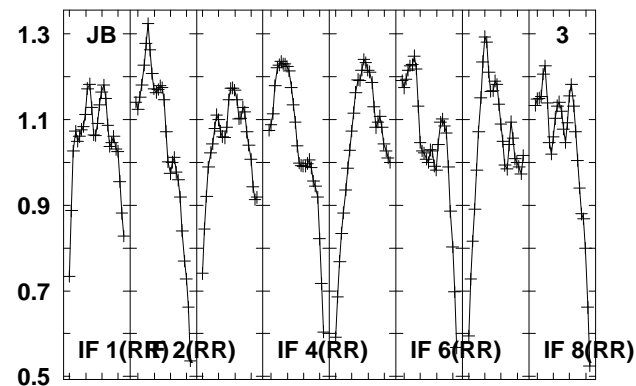
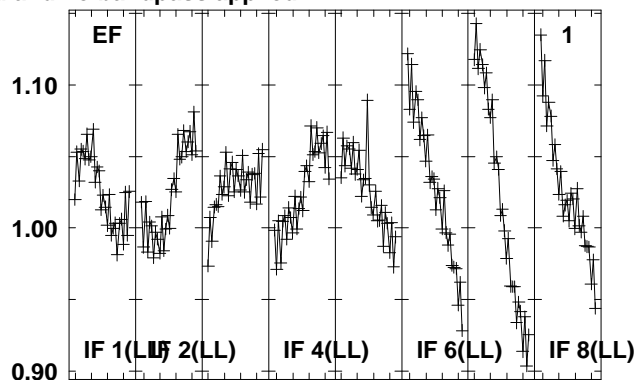
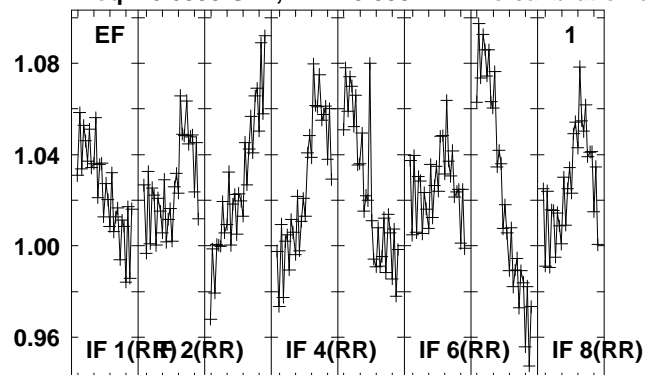

Lower frame: Real Jy

Total-power spectrum Antenna: *

Timerange: 00/10:11:56 to 00/10:13:24

Plot file version 16 created 15-MAR-2012 17:30:40

G85.40 EZ020E 2.UVDATA.1

Freq = 6.6335 GHz, Bw = 8.000 MH No calibration applied and no bandpass applied

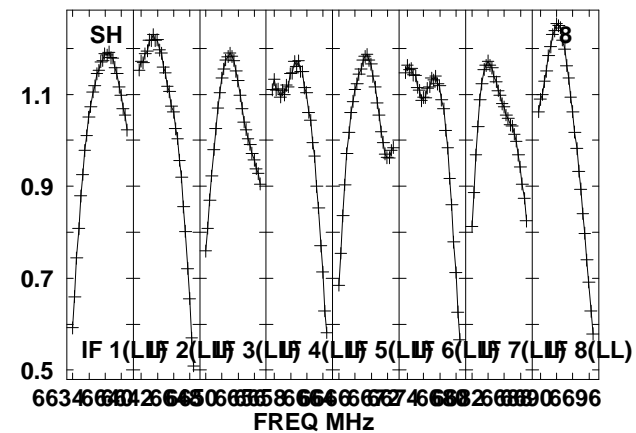
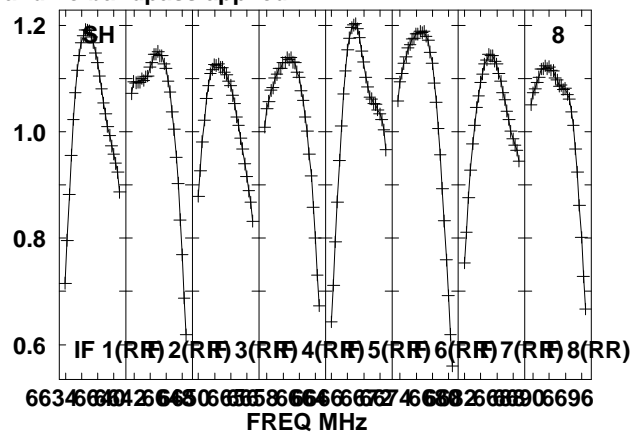
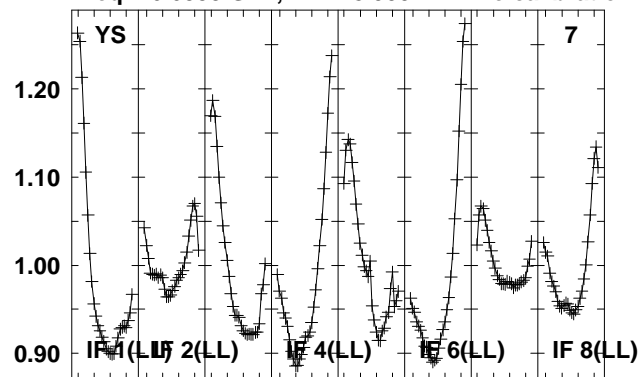

Lower frame: Real Jy
Total-power spectrum Antenna: *
Timerange: 00/10:11:56 to 00/10:13:24

Plot file version 17 created 15-MAR-2012 17:30:41

2114-G85 EZ020E 2.UVDATA.1

Freq = 6.6335 GHz, Bw = 8.000 MH No calibration applied and no bandpass applied

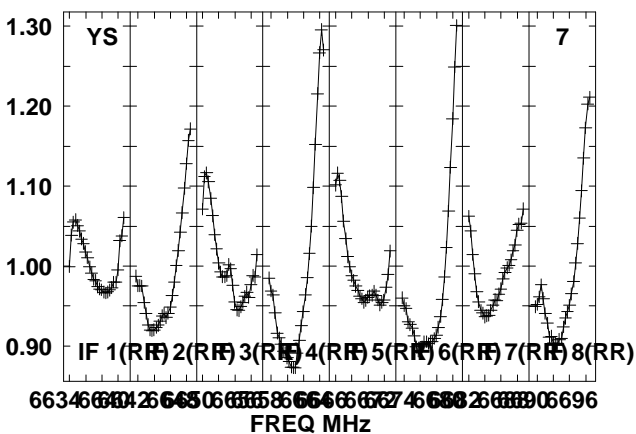
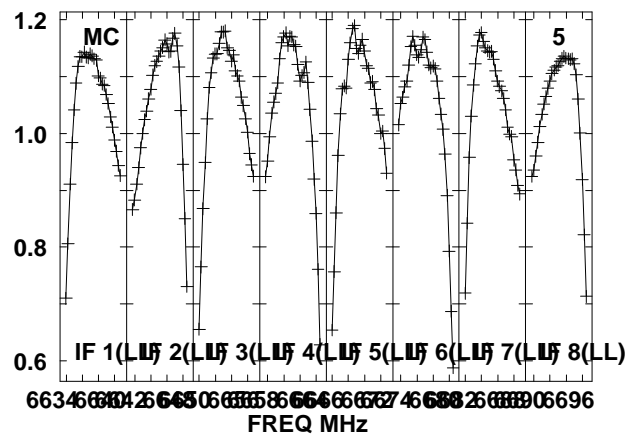
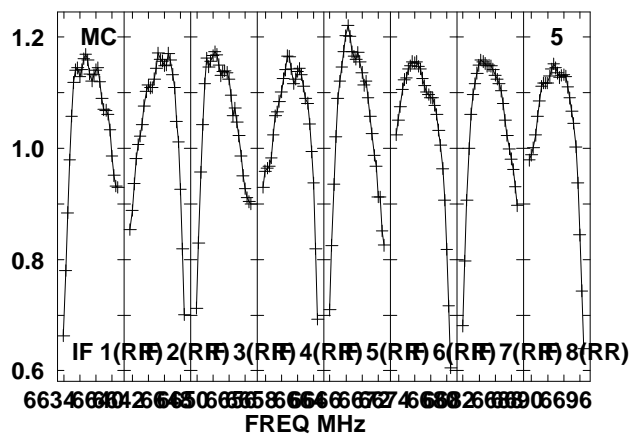
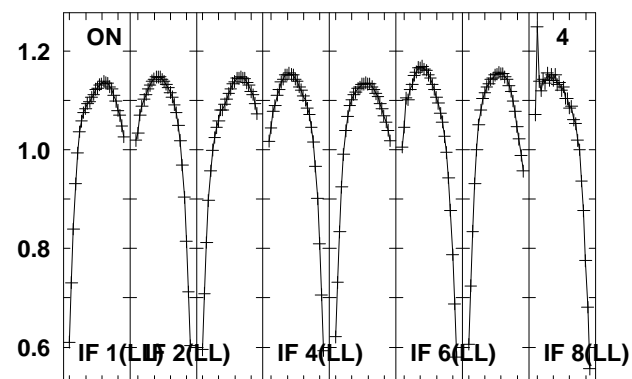
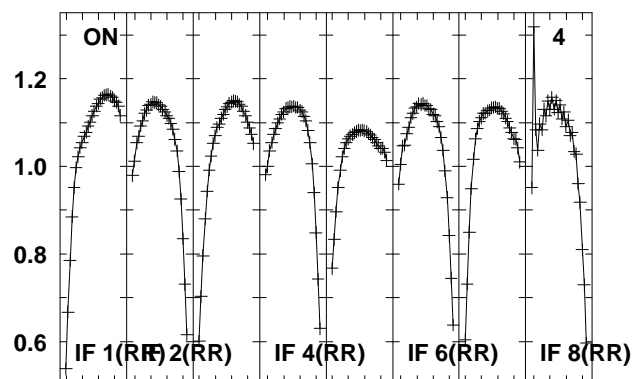
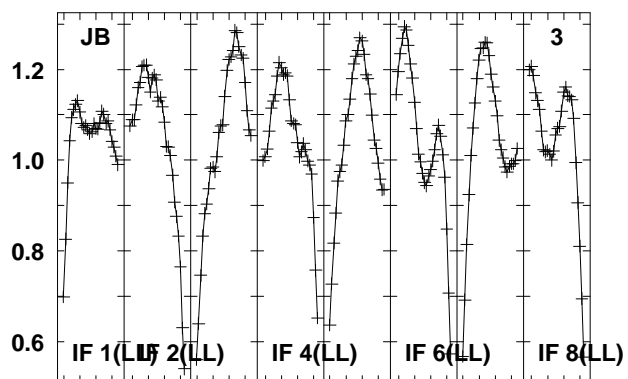
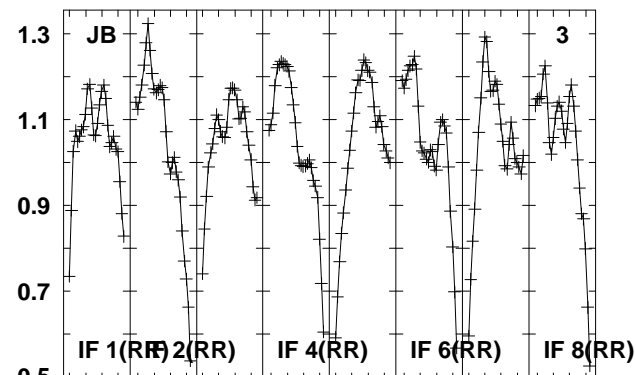
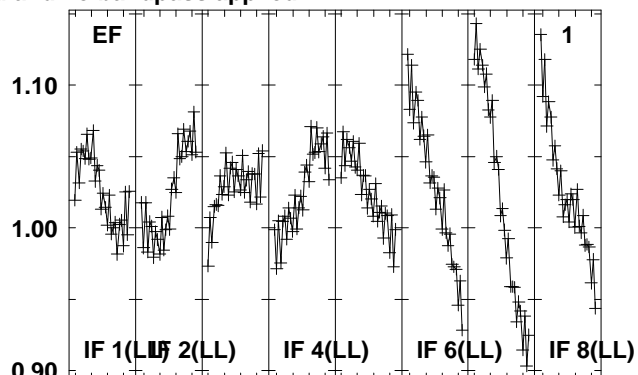
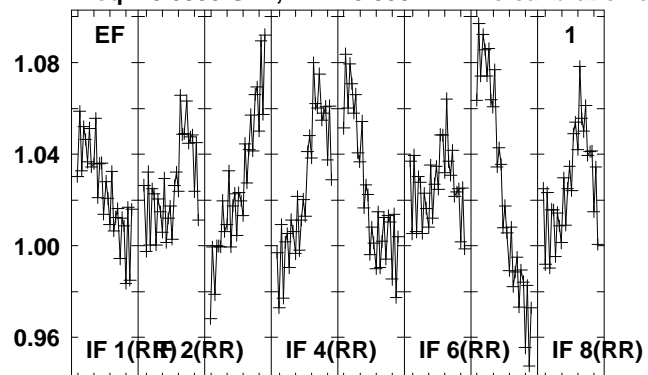

Lower frame: Real Jy
Total-power spectrum Antenna: *
Timerange: 00/10/13:25 to 00/10/14:53

Plot file version 18 created 15-MAR-2012 17:30:41

2114-G85 EZ020E 2.UVDATA.1

Freq = 6.6335 GHz, Bw = 8.000 MH No calibration applied and no bandpass applied

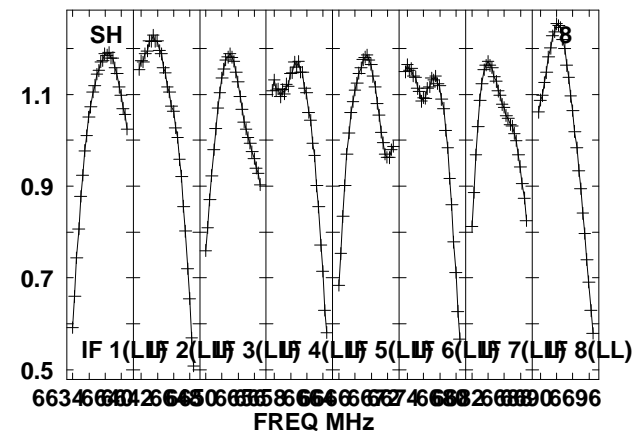
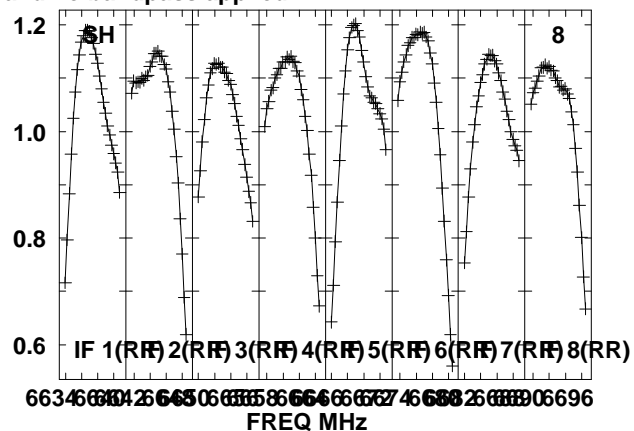
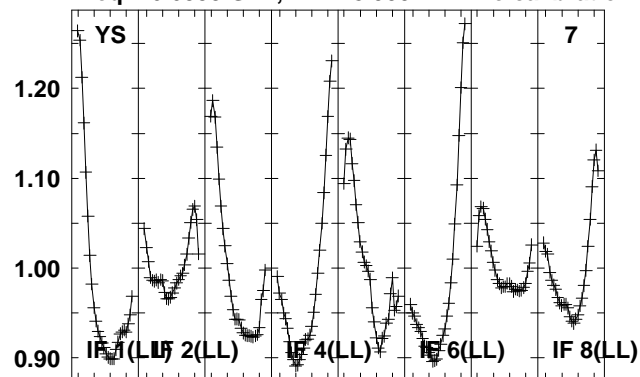

Lower frame: Real Jy
Total-power spectrum Antenna: *
Timerange: 00/10:13:25 to 00/10:14:53

Plot file version 19 created 15-MAR-2012 17:30:42

G85.40 EZ20E 2.UVDATA.1

Freq = 6.6335 GHz, Bw = 8.000 MH No calibration applied and no bandpass applied

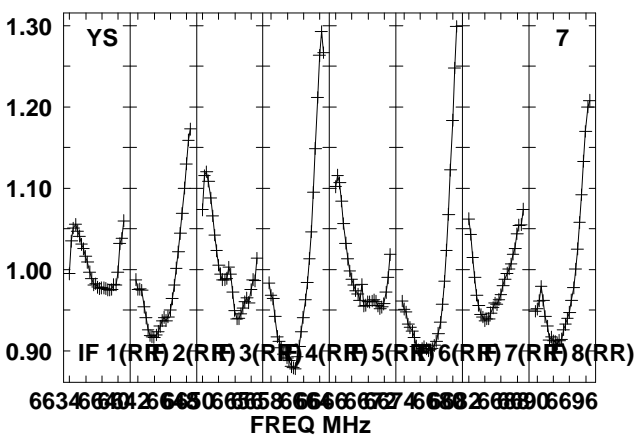
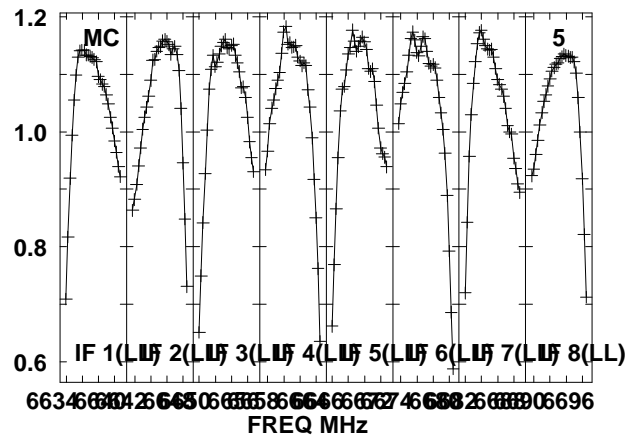
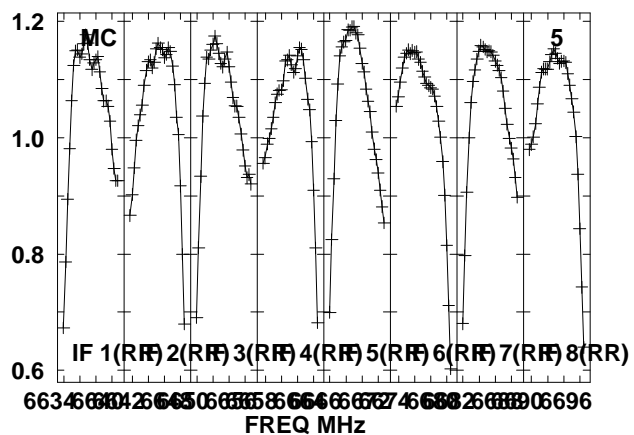
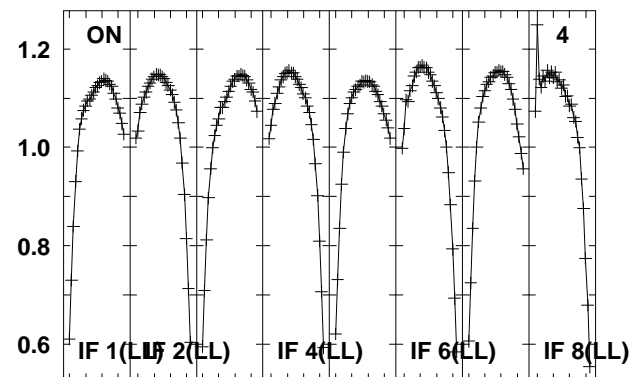
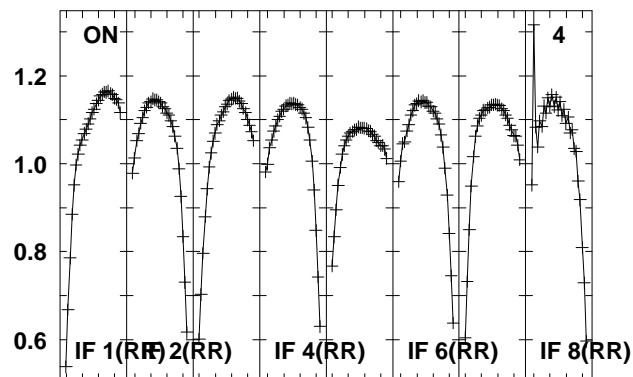
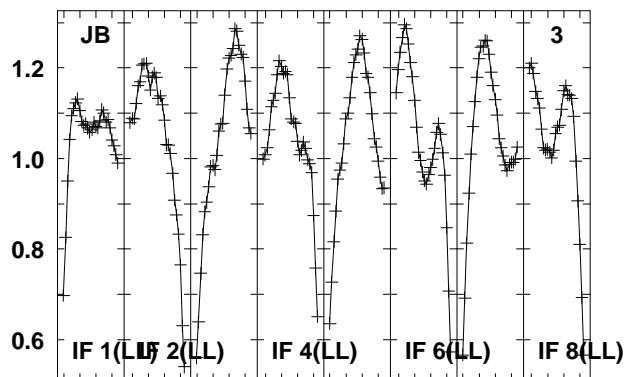
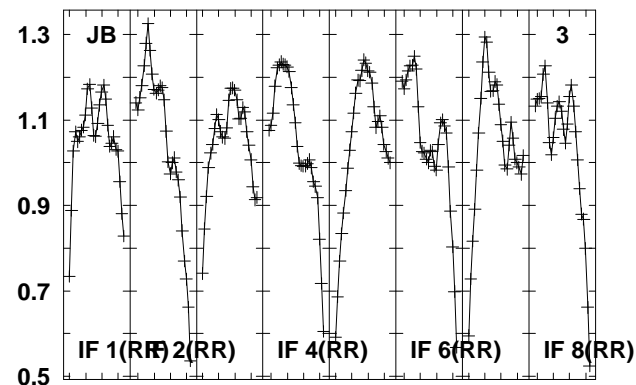
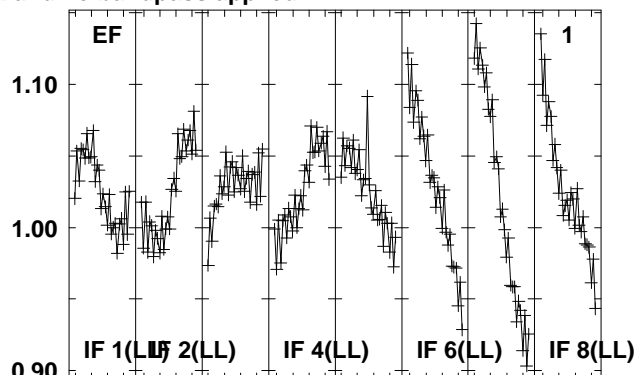
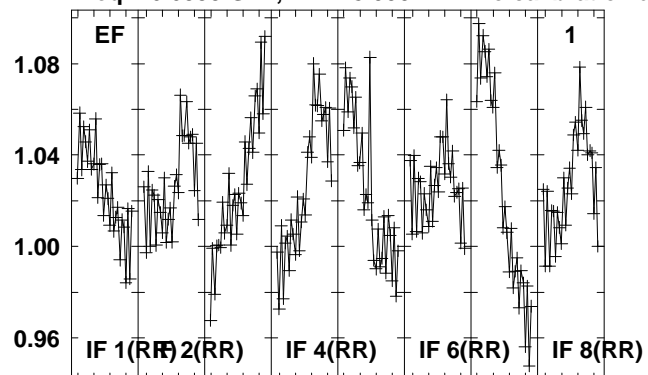

Lower frame: Real Jy
Total-power spectrum Antenna: *
Timerange: 00/10:14:55 to 00/10:16:24

Plot file version 20 created 15-MAR-2012 17:30:42

G85.40 EZ020E 2.UVDATA.1

Freq = 6.6335 GHz, Bw = 8.000 MH No calibration applied and no bandpass applied

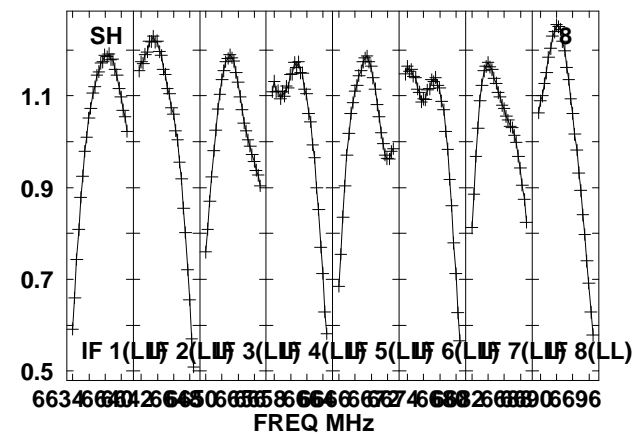
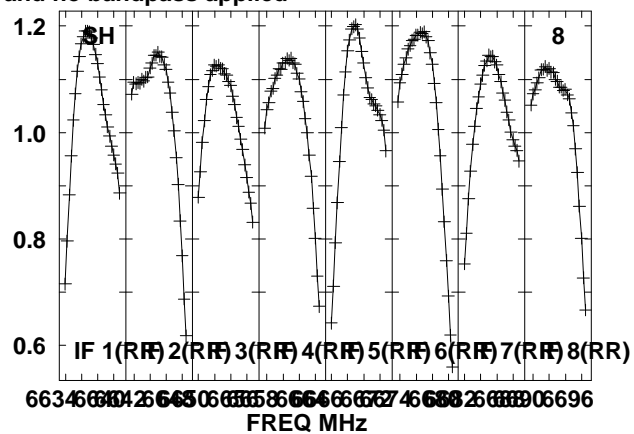
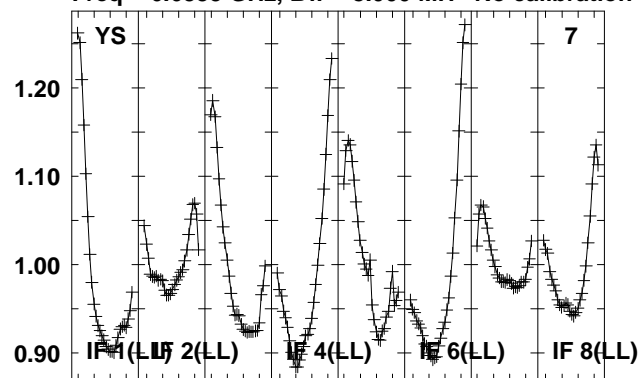

Lower frame: Real Jy
Total-power spectrum Antenna: *
Timerange: 00/10:14:55 to 00/10:16:24

Plot file version 21 created 15-MAR-2012 17:30:43
 2102-G85 EZ020E 2.UVDATA.1
 Freq = 6.6335 GHz, Bw = 8.000 MH No calibration applied and no bandpass applied

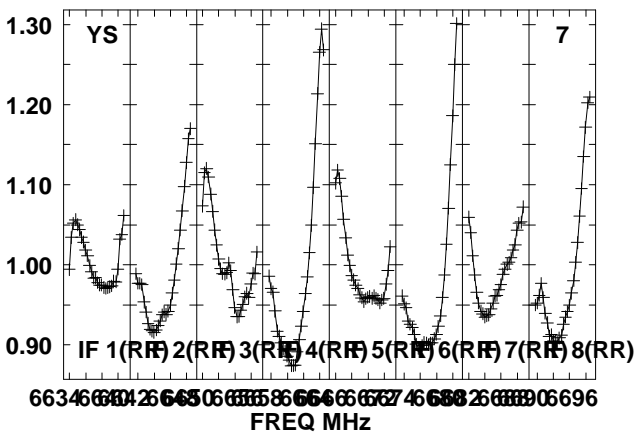
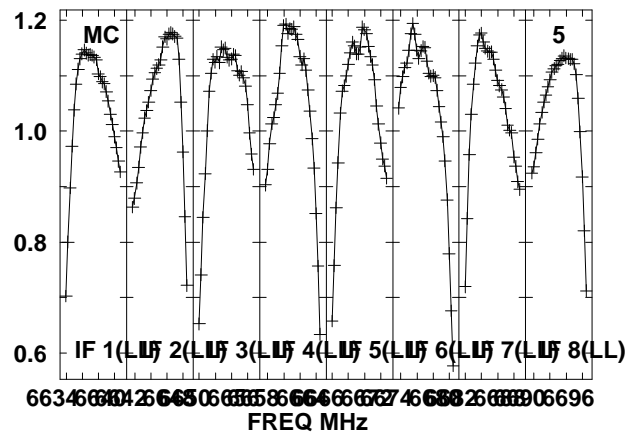
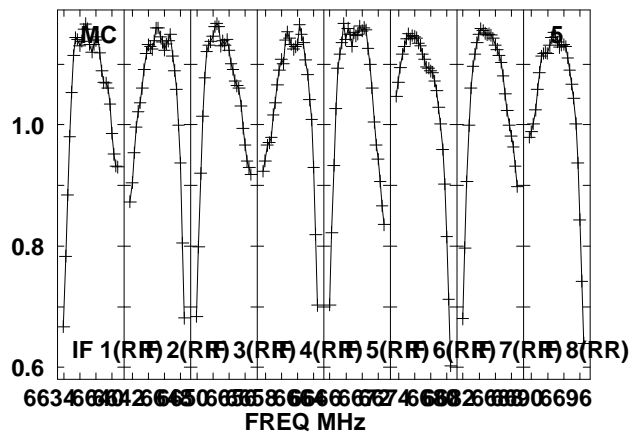
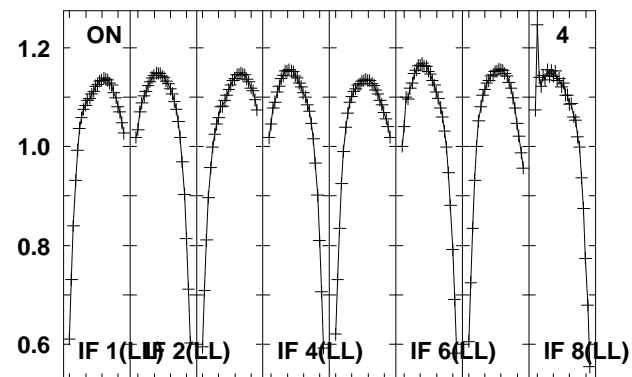
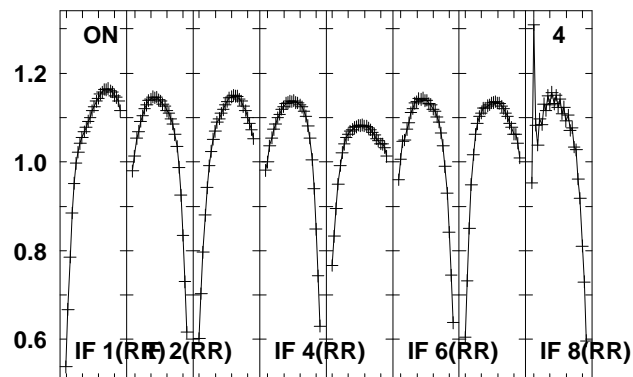
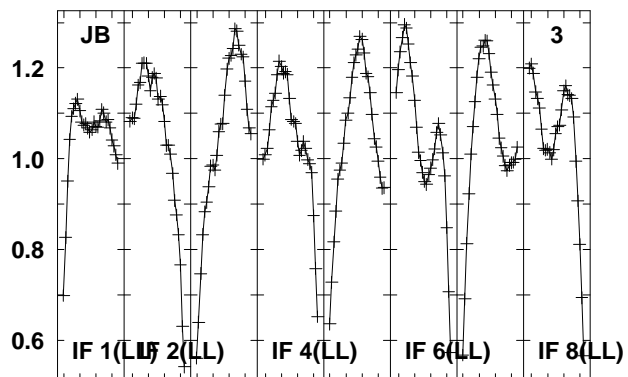
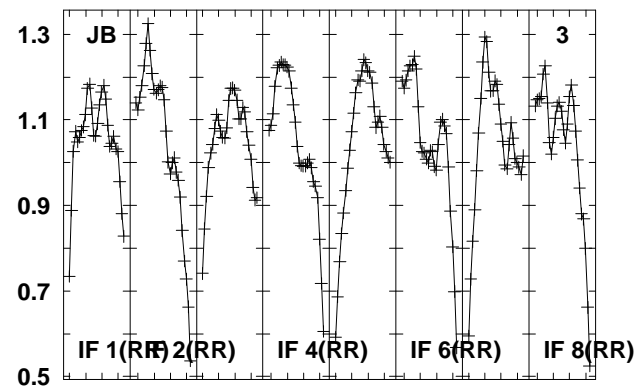
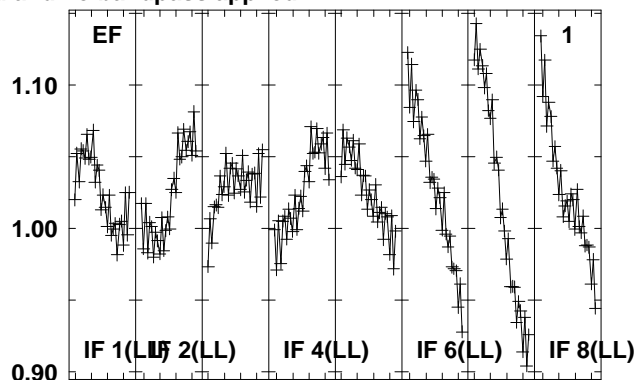
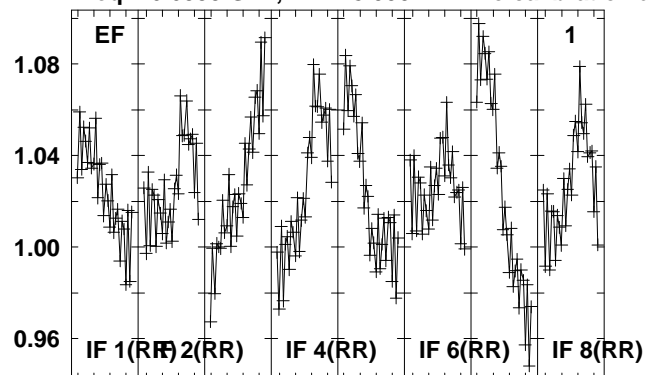

Lower frame: Real Jy
 Total-power spectrum Antenna: *
 Timerange: 00/10:16:26 to 00/10:17:54

Plot file version 22 created 15-MAR-2012 17:30:43

2102-G85 EZ020E 2.UVDATA.1

Freq = 6.6335 GHz, Bw = 8.000 MH No calibration applied and no bandpass applied

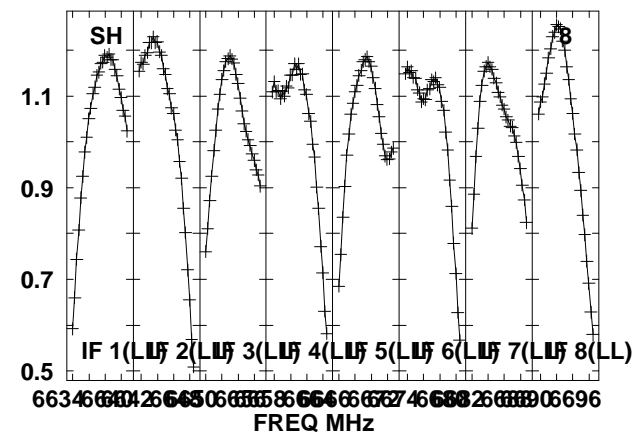
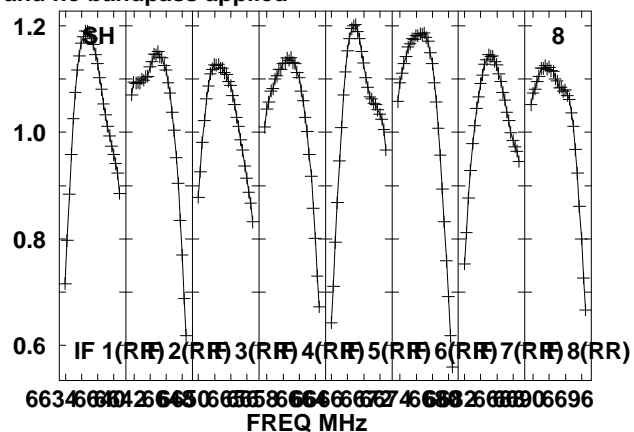
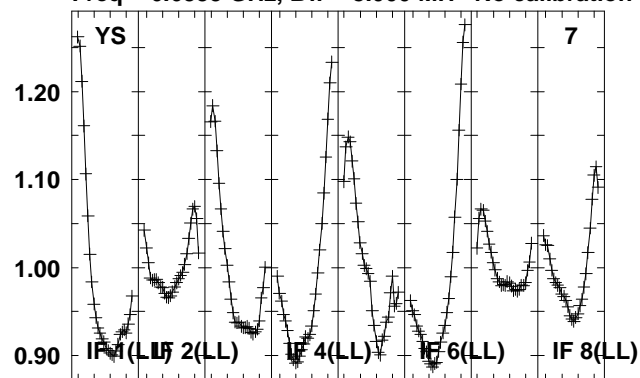

Lower frame: Real Jy
Total-power spectrum Antenna: *
Timerange: 00/10:16:26 to 00/10:17:54

Plot file version 23 created 15-MAR-2012 17:30:44

G85.40 EZ020E 2.UVDATA.1

Freq = 6.6335 GHz, Bw = 8.000 MH No calibration applied and no bandpass applied

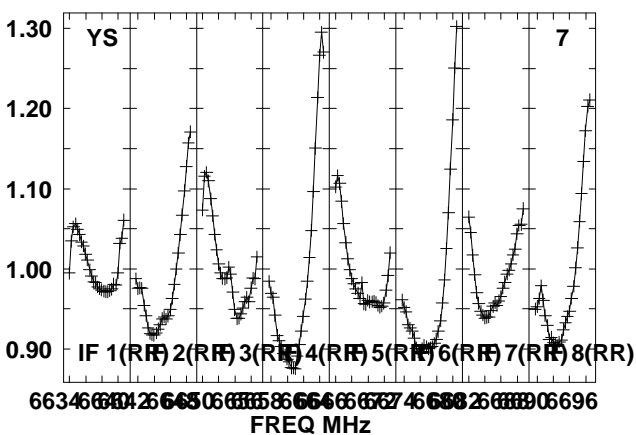
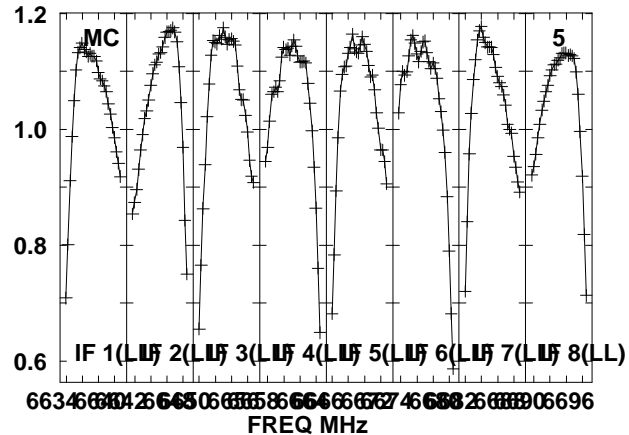
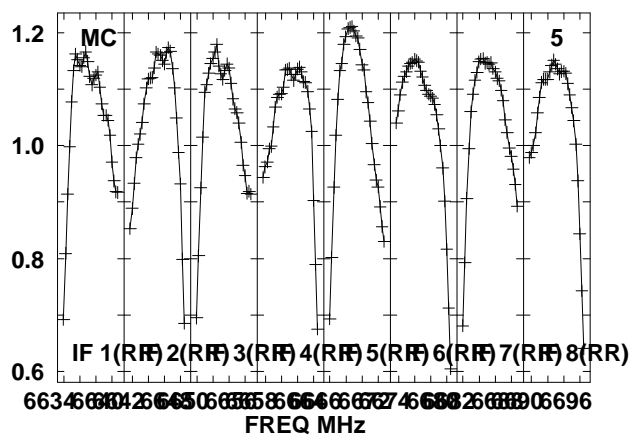
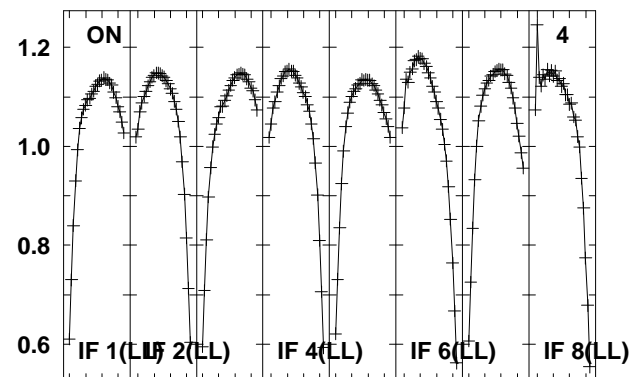
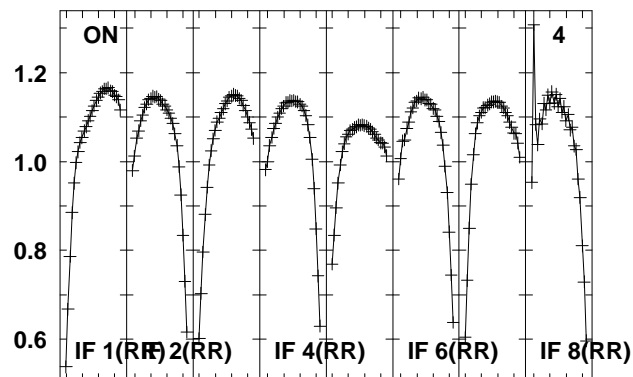
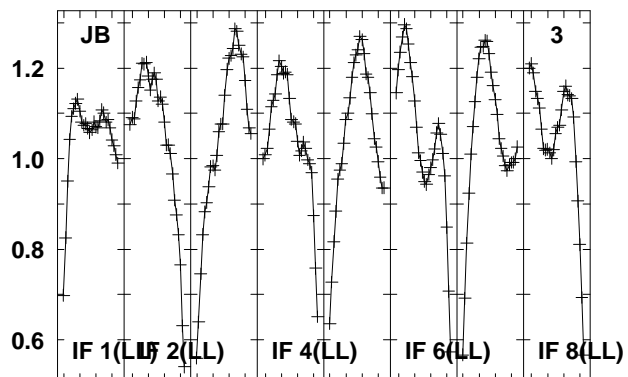
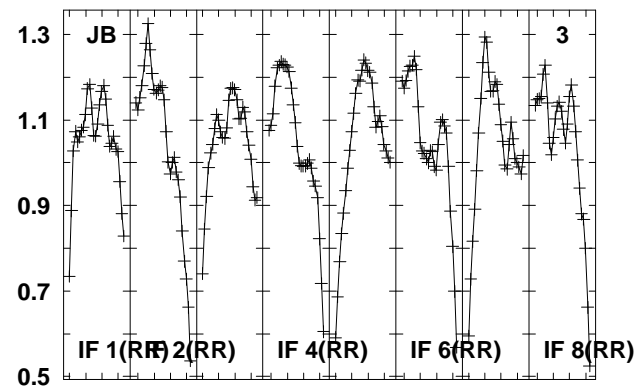
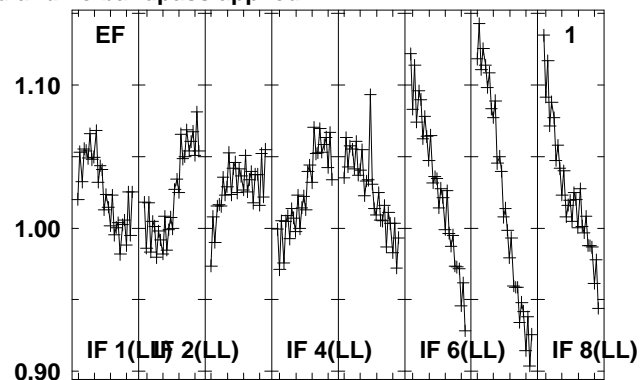
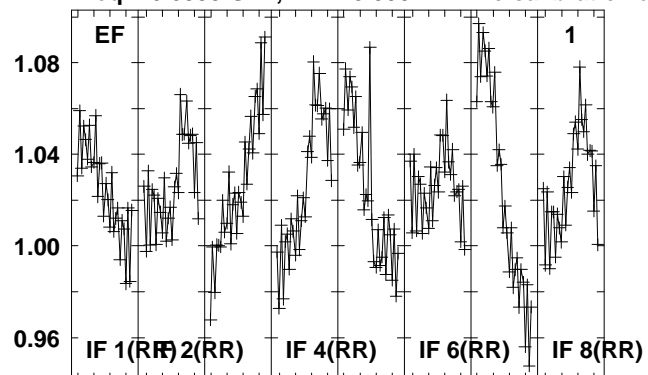

Lower frame: Real Jy
Total-power spectrum Antenna: *
Timerange: 00/10:18:28 to 00/10:19:25

Plot file version 24 created 15-MAR-2012 17:30:45

G85.40 EZ020E 2.UVDATA.1

Freq = 6.6335 GHz, Bw = 8.000 MH No calibration applied and no bandpass applied

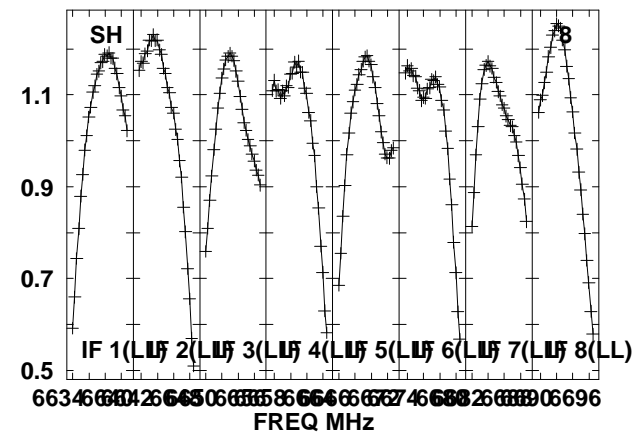
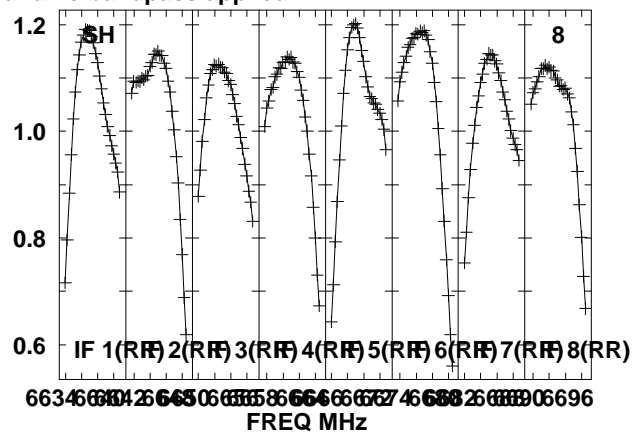
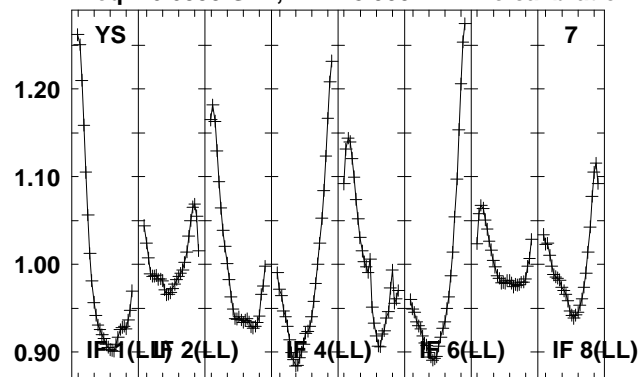

Lower frame: Real Jy
Total-power spectrum Antenna: *
Timerange: 00/10:18:28 to 00/10:19:25

Plot file version 25 created 15-MAR-2012 17:30:46

2114-G85 EZ020E 2.UVDATA.1

Freq = 6.6335 GHz, Bw = 8.000 MH No calibration applied and no bandpass applied

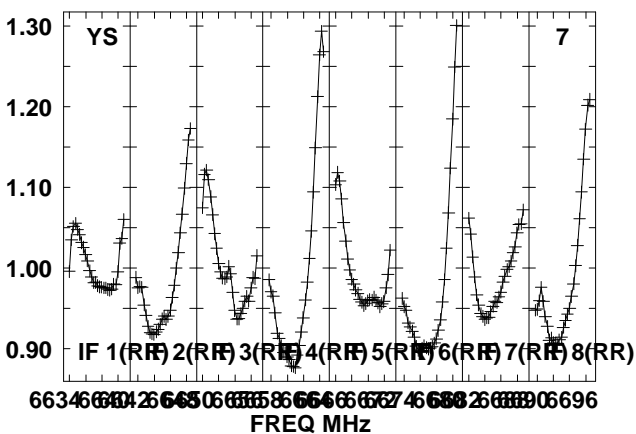
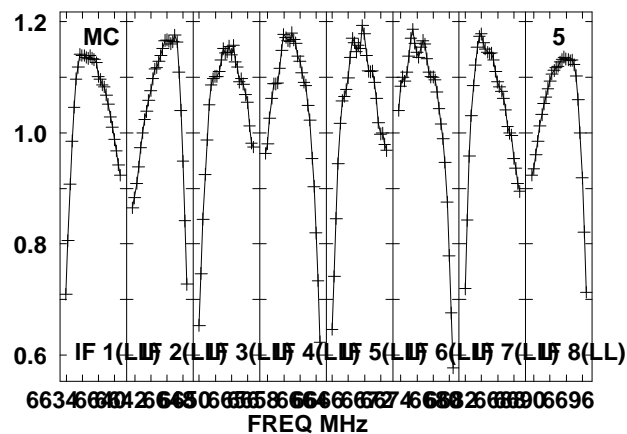
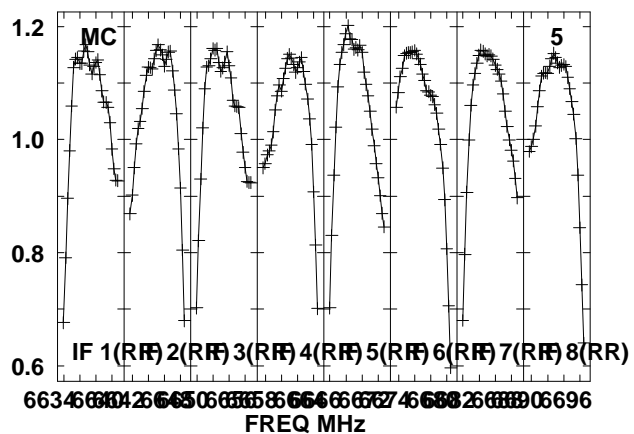
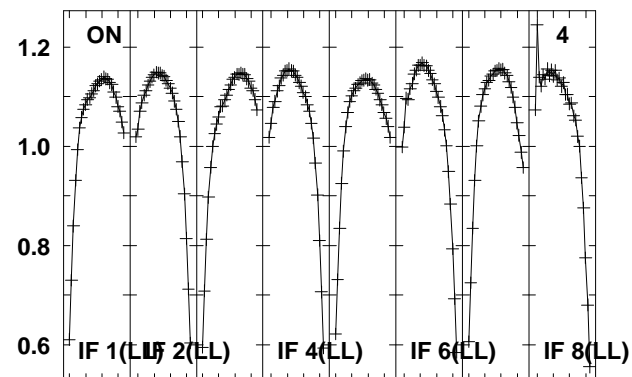
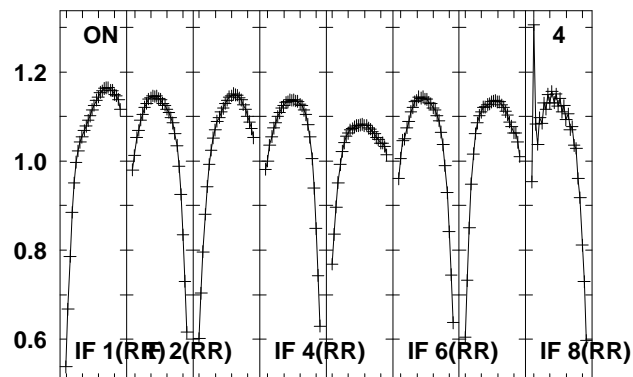
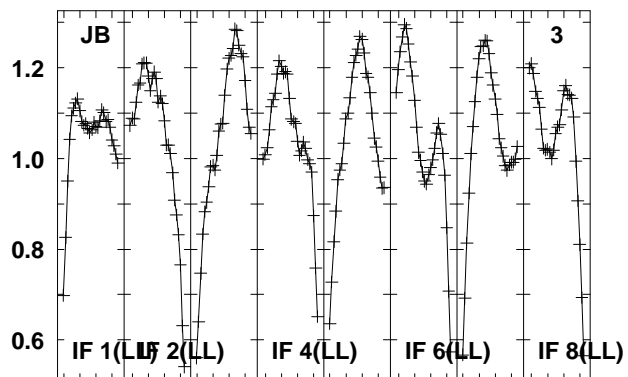
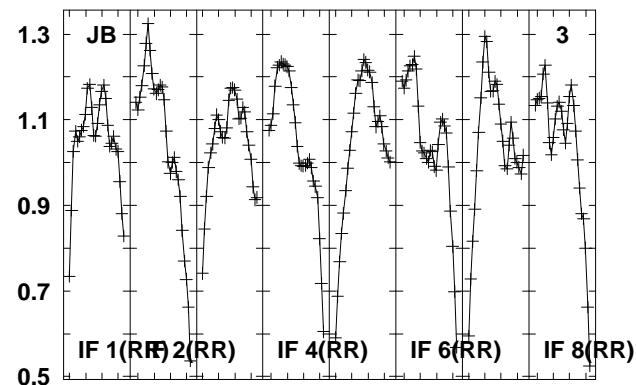
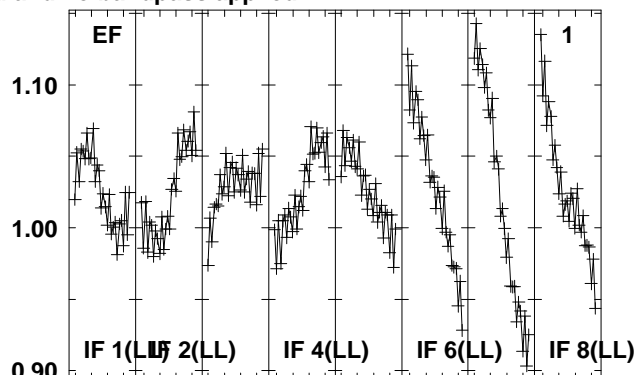
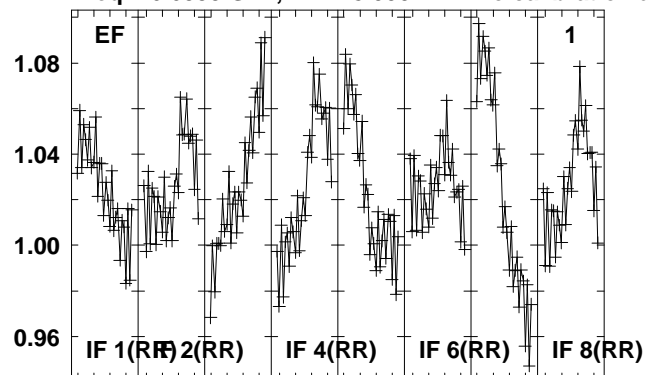

Lower frame: Real Jy
Total-power spectrum Antenna: *
Timerange: 00/10:19:27 to 00/10:20:55

Plot file version 26 created 15-MAR-2012 17:30:46

2114-G85 EZ020E 2.UVDATA.1

Freq = 6.6335 GHz, Bw = 8.000 MH No calibration applied and no bandpass applied

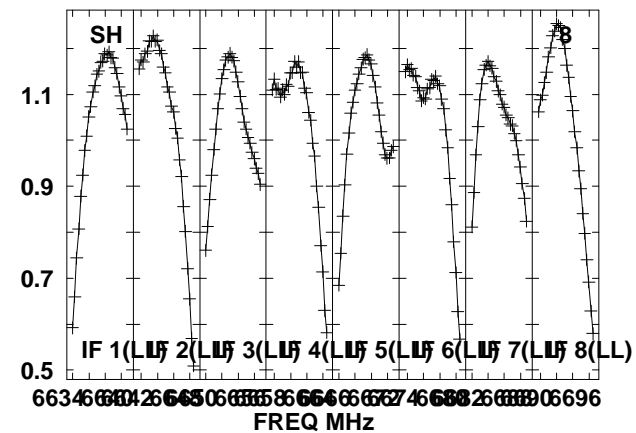
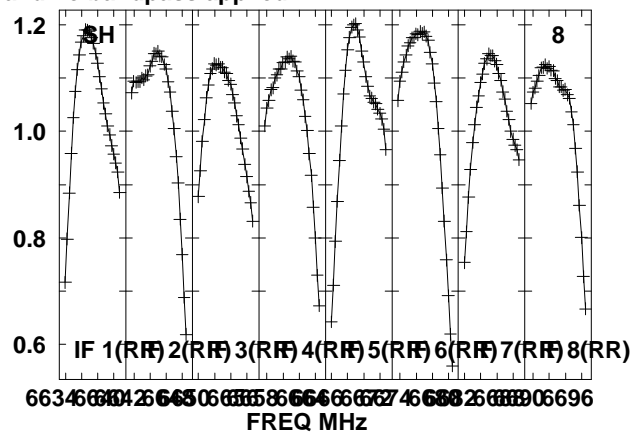
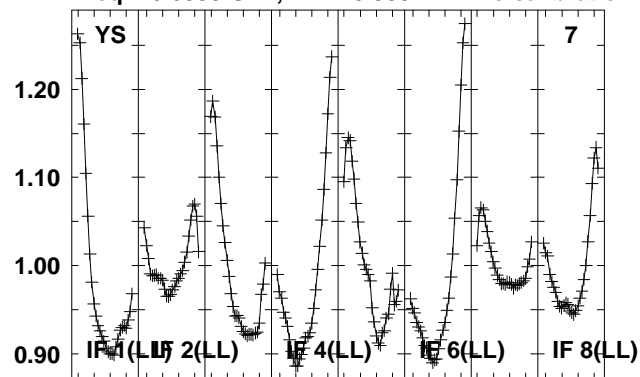

Lower frame: Real Jy
Total-power spectrum Antenna: *
Timerange: 00/10:19:27 to 00/10:20:55

Plot file version 27 created 15-MAR-2012 17:30:47

G85.40 EZ020E 2.UVDATA.1

Freq = 6.6335 GHz, Bw = 8.000 MH No calibration applied and no bandpass applied

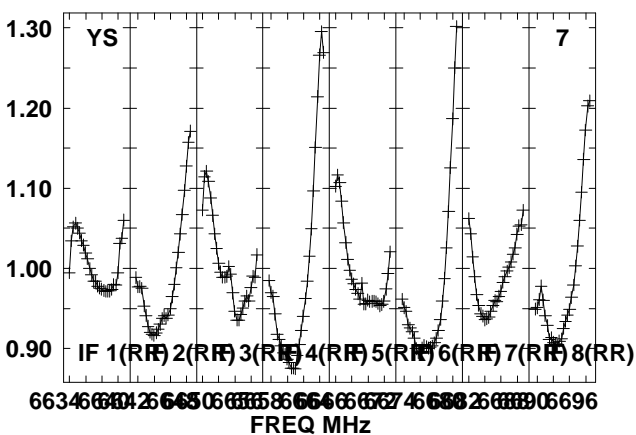
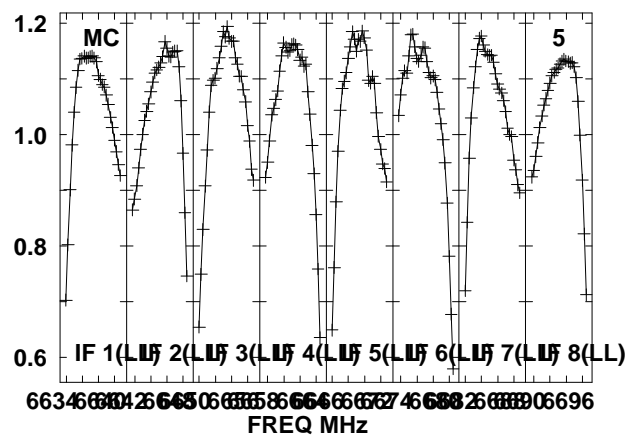
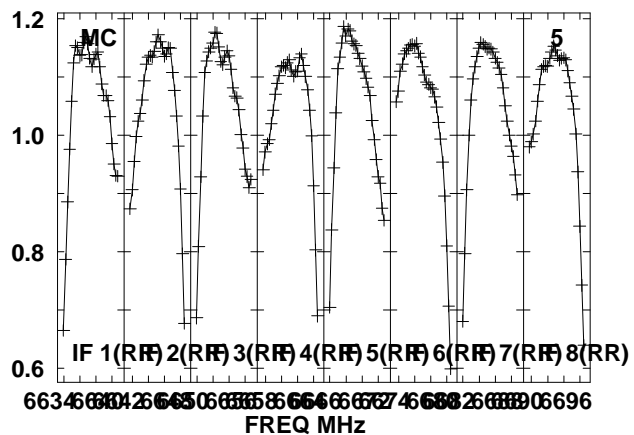
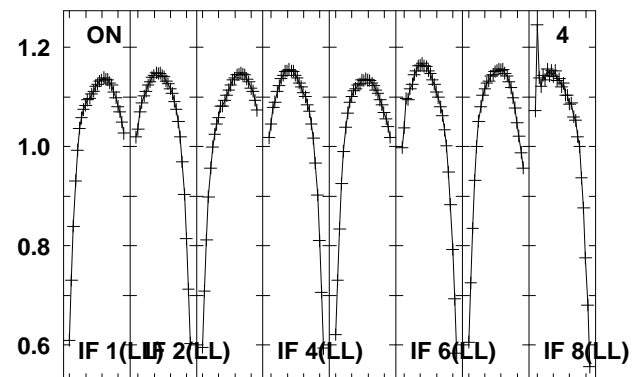
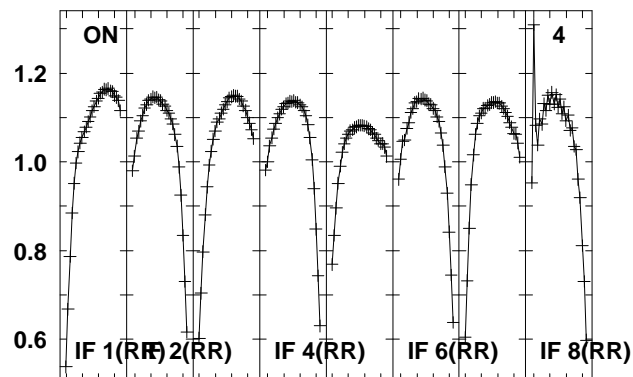
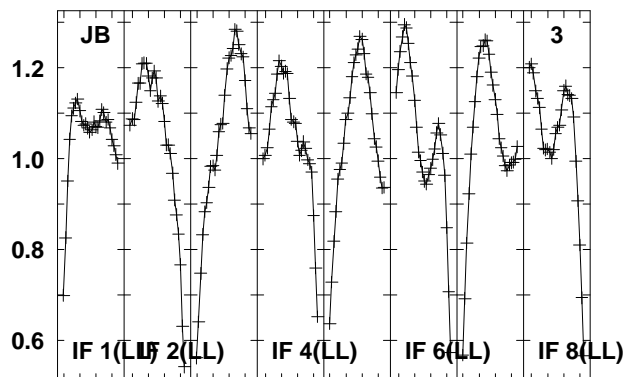
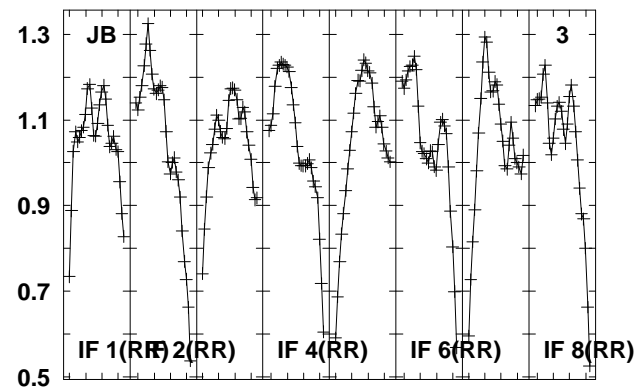
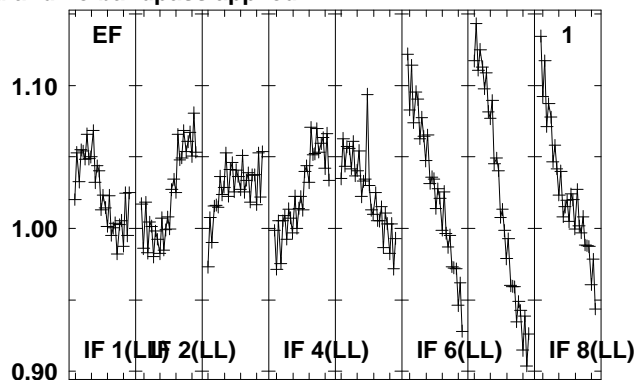
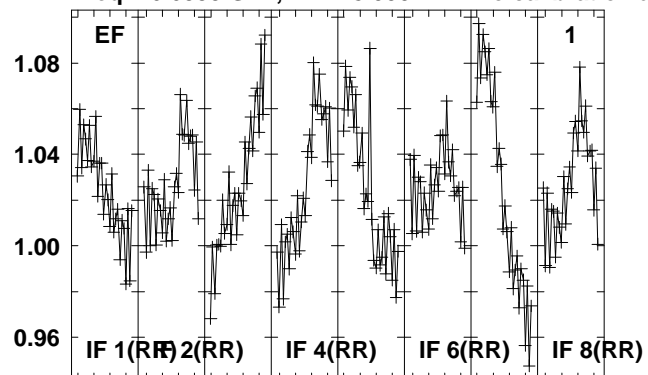

Lower frame: Real Jy
Total-power spectrum Antenna: *
Timerange: 00/10:20:58 to 00/10:22:26

Plot file version 28 created 15-MAR-2012 17:30:47

G85.40 EZ020E 2.UVDATA.1

Freq = 6.6335 GHz, Bw = 8.000 MH No calibration applied and no bandpass applied

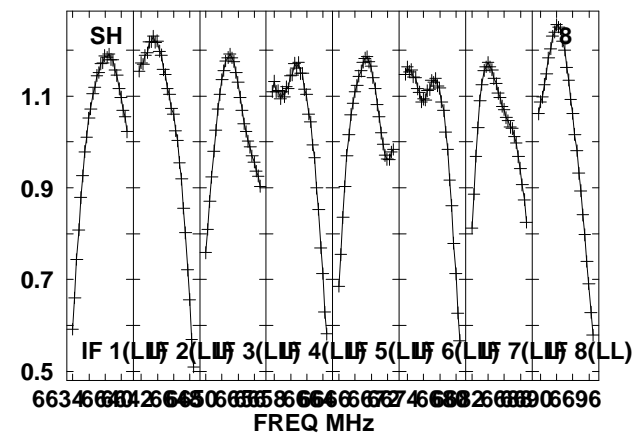
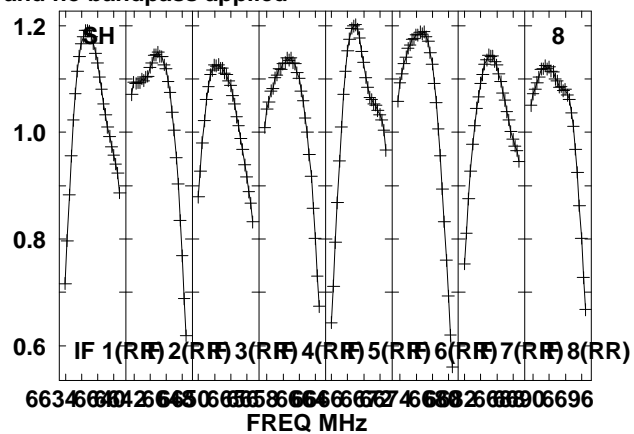
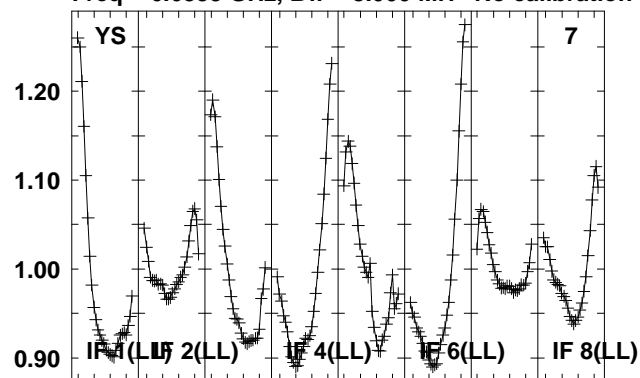

Lower frame: Real Jy
Total-power spectrum Antenna: *
Timerange: 00/10:20:58 to 00/10:22:26

Plot file version 29 created 15-MAR-2012 17:30:48

2102-G85 EZ020E 2.UVDATA.1

Freq = 6.6335 GHz, Bw = 8.000 MH No calibration applied and no bandpass applied

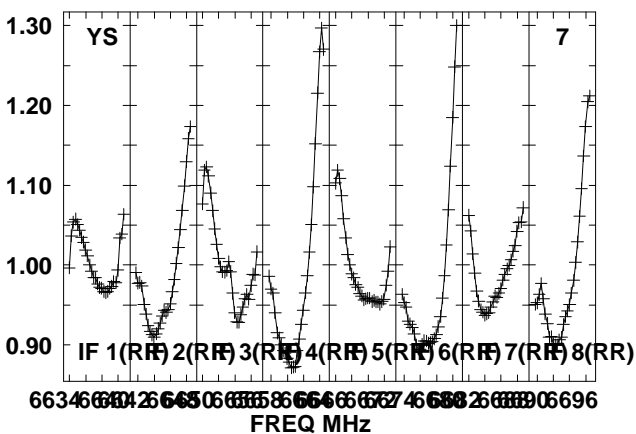
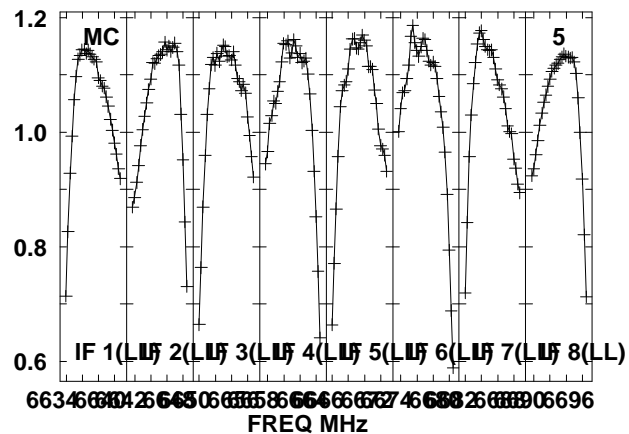
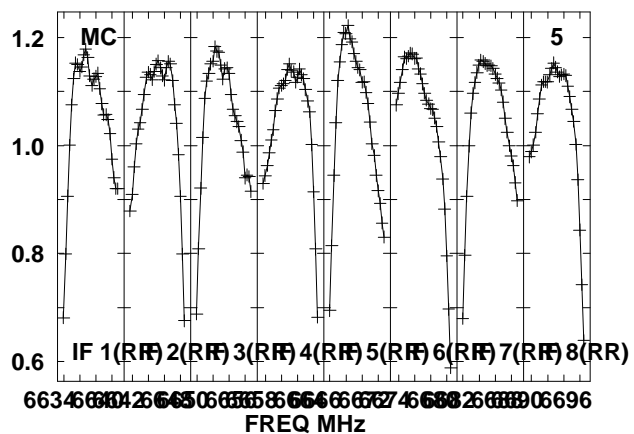
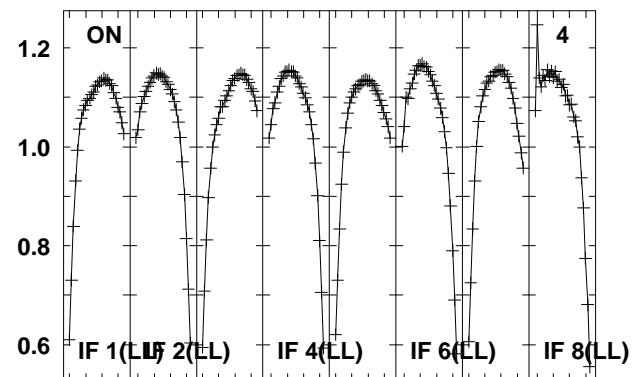
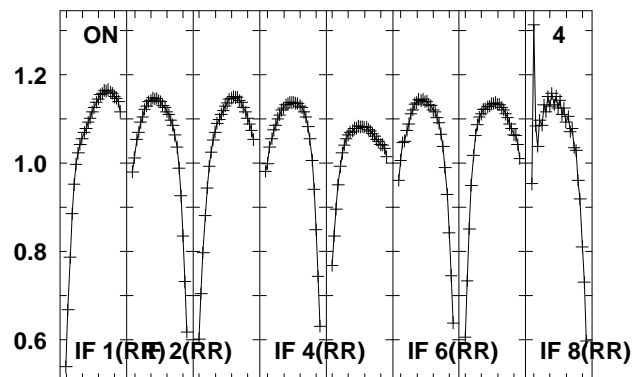
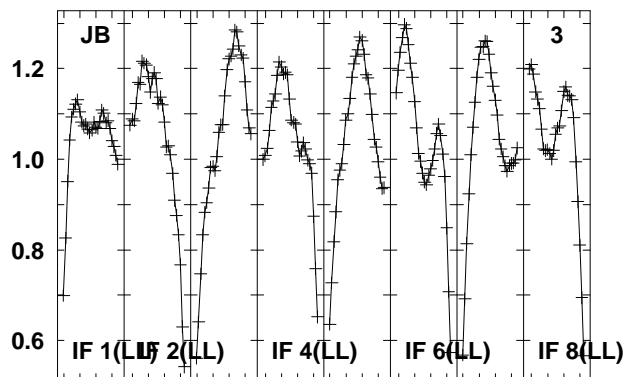
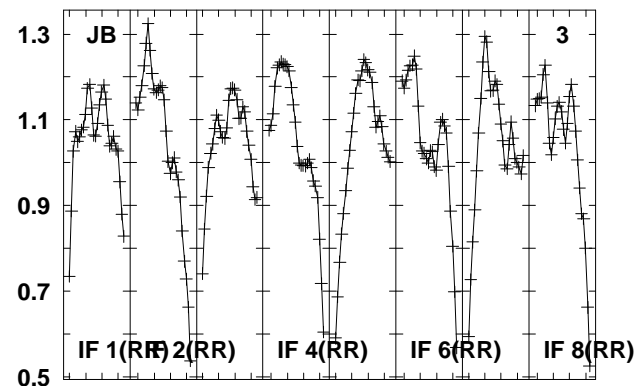
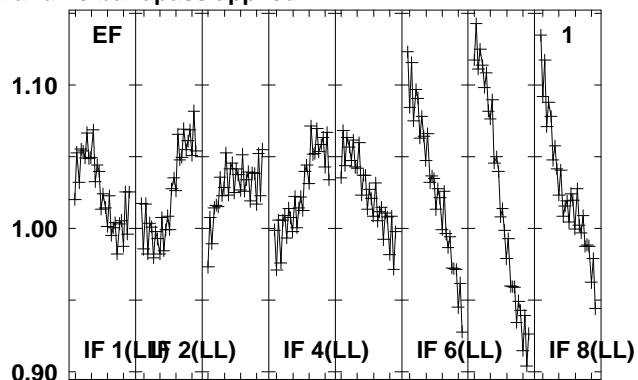
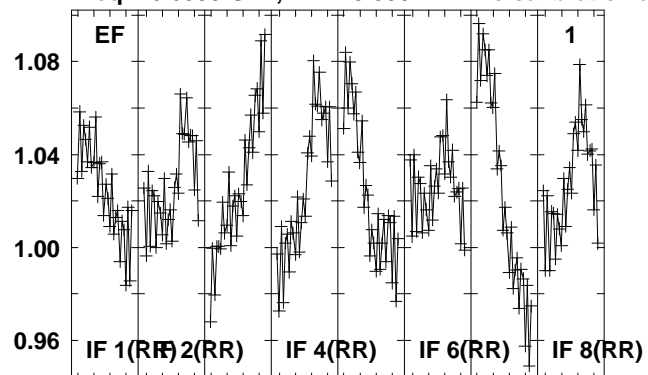

Lower frame: Real Jy
Total-power spectrum Antenna: *
Timerange: 00/10:22:27 to 00/10:23:55

Plot file version 30 created 15-MAR-2012 17:30:48

2102-G85 EZ020E 2.UVDATA.1

Freq = 6.6335 GHz, Bw = 8.000 MH No calibration applied and no bandpass applied

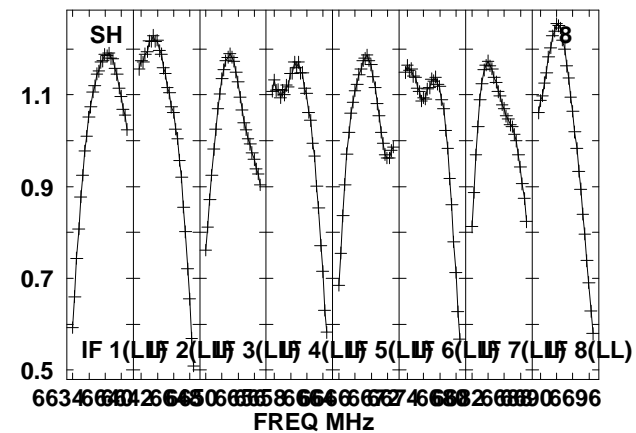
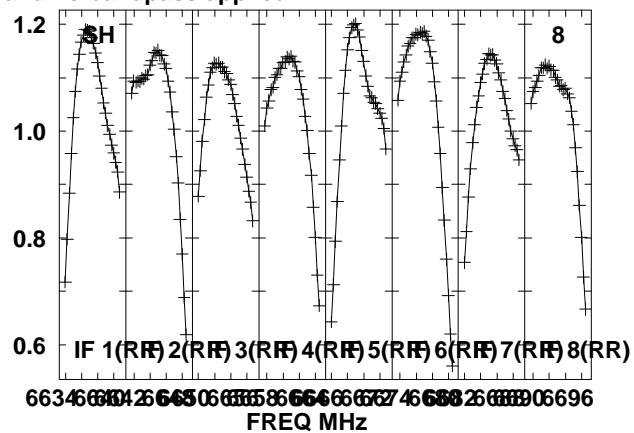
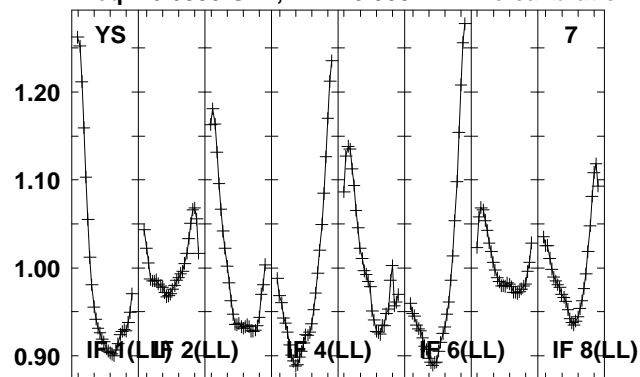

Lower frame: Real Jy
Total-power spectrum Antenna: *
Timerange: 00/10:22:27 to 00/10:23:55

Plot file version 31 created 15-MAR-2012 17:30:49

G85.40 EZ020E 2.UVDATA.1

Freq = 6.6335 GHz, Bw = 8.000 MH No calibration applied and no bandpass applied

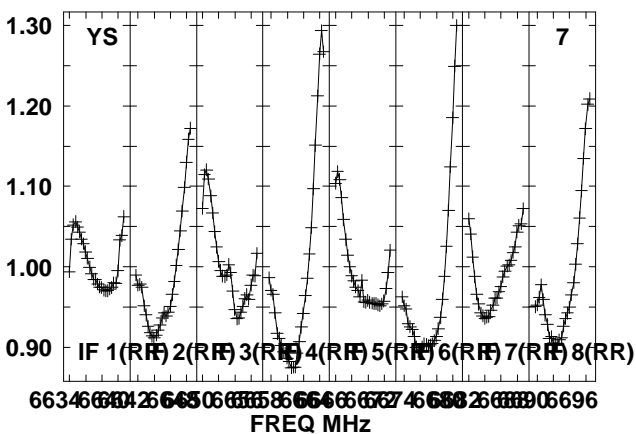
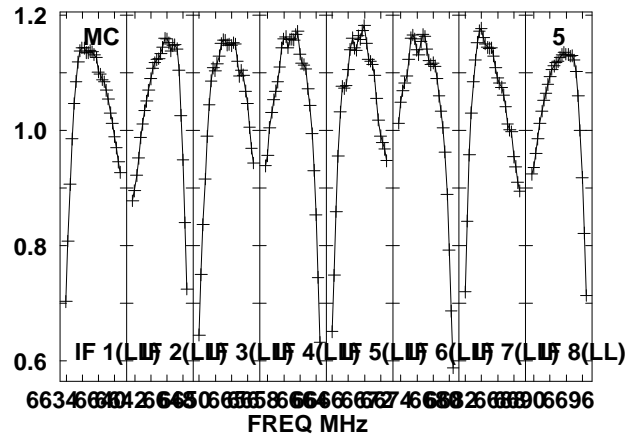
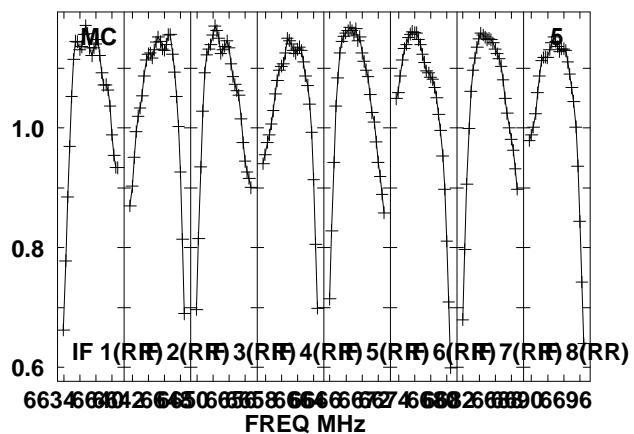
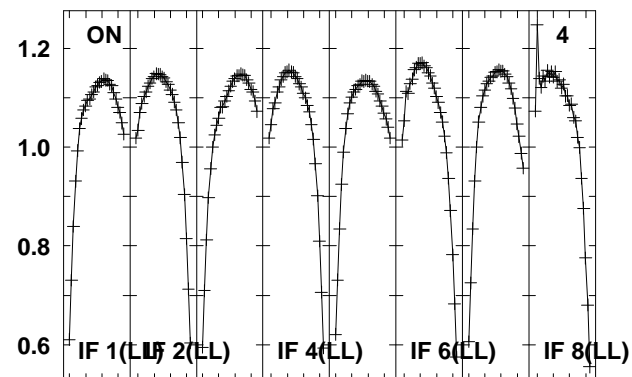
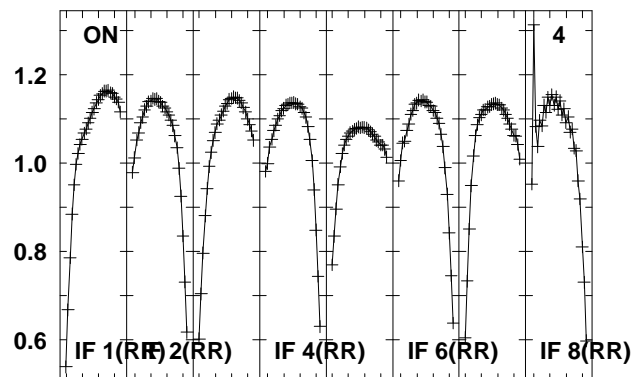
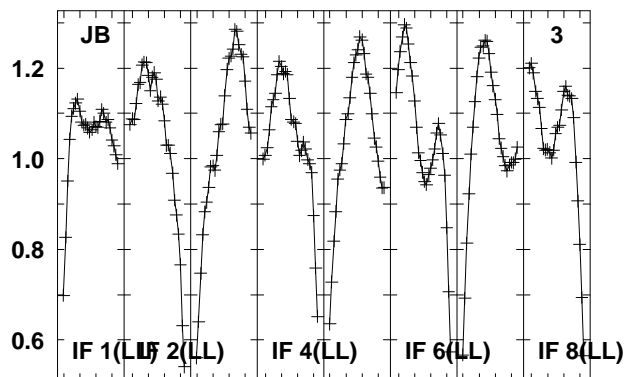
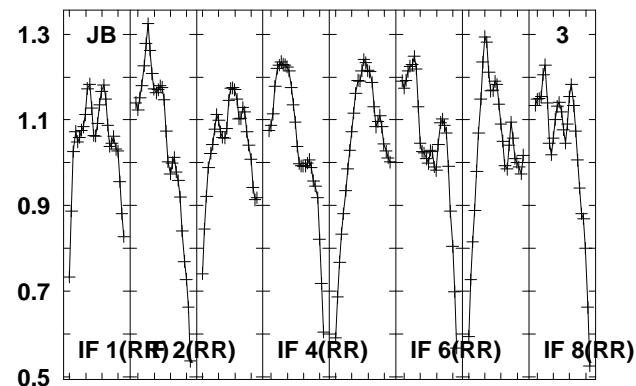
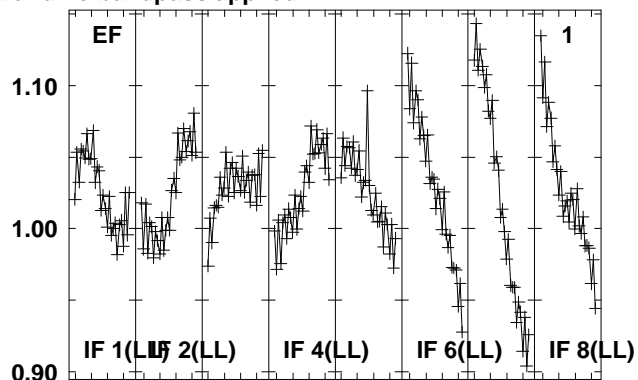
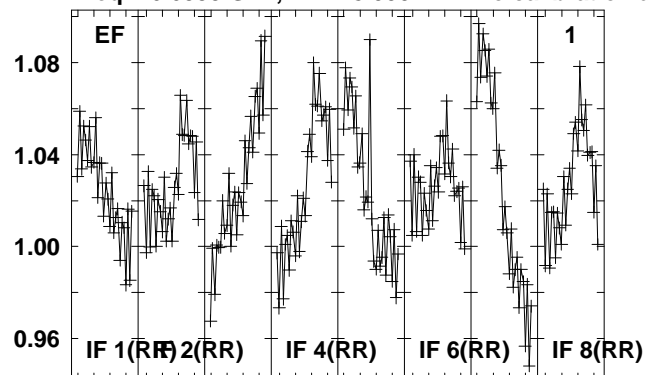

Lower frame: Real Jy
Total-power spectrum Antenna: *
Timerange: 00/10:23:58 to 00/10:25:26

Plot file version 32 created 15-MAR-2012 17:30:49

G85.40 EZ020E 2.UVDATA.1

Freq = 6.6335 GHz, Bw = 8.000 MH No calibration applied and no bandpass applied

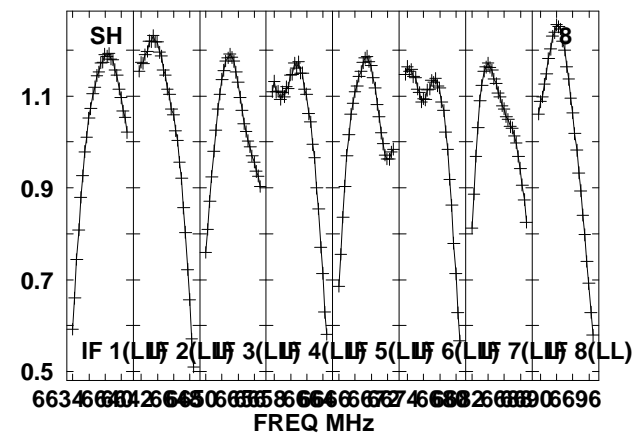
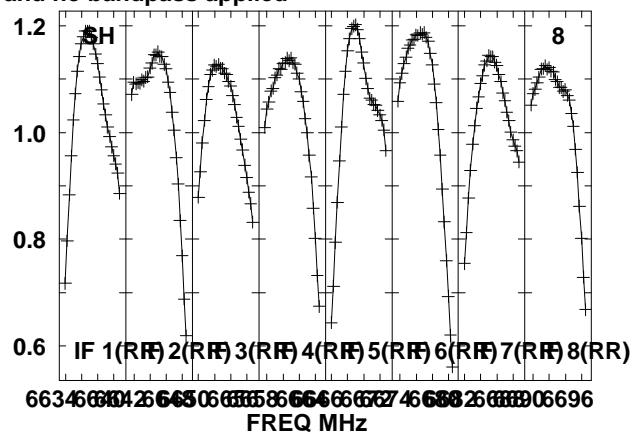
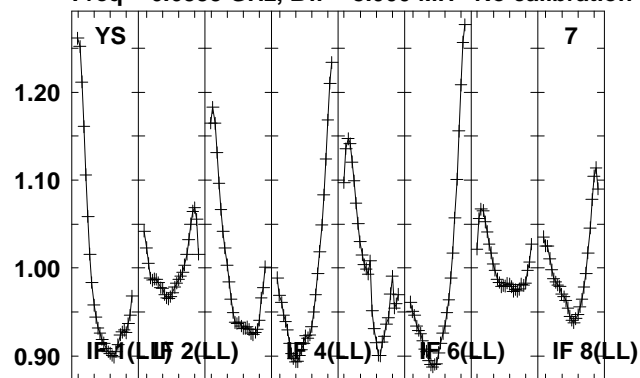

Lower frame: Real Jy
Total-power spectrum Antenna: *
Timerange: 00/10:23:58 to 00/10:25:26

Plot file version 33 created 15-MAR-2012 17:30:50

2114-G85 EZ020E 2.UVDATA.1

Freq = 6.6335 GHz, Bw = 8.000 MH No calibration applied and no bandpass applied

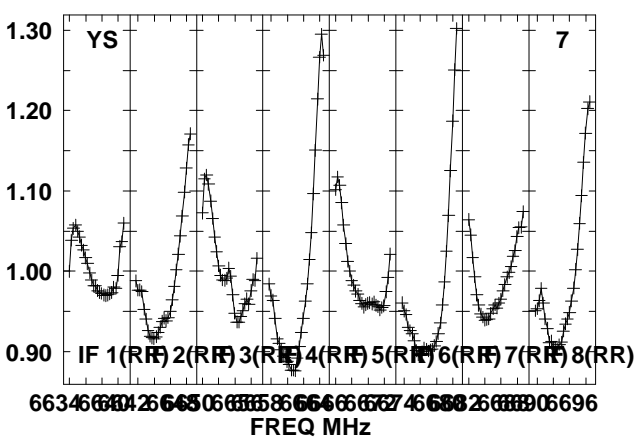
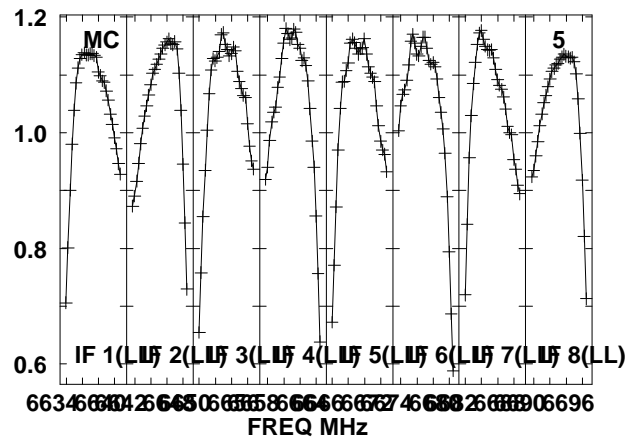
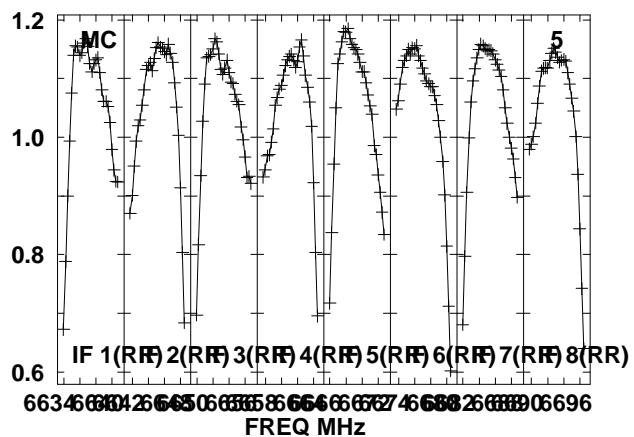
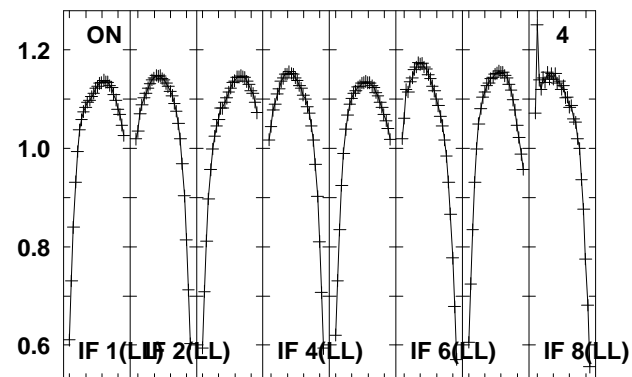
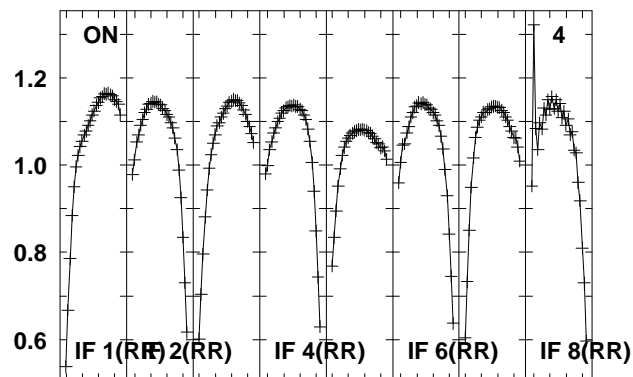
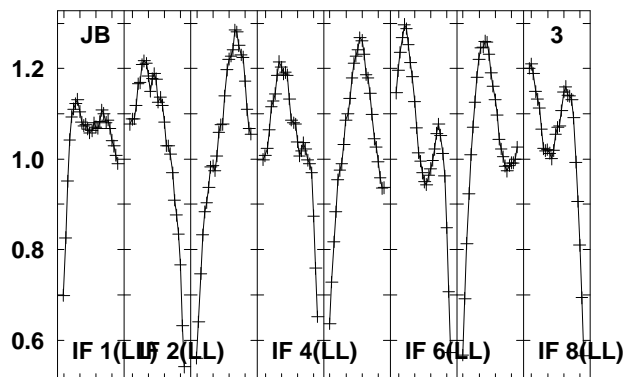
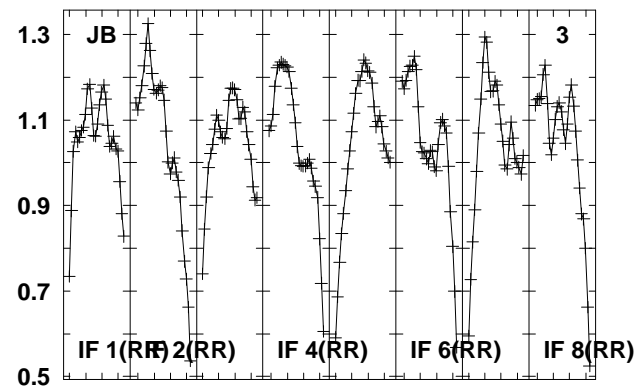
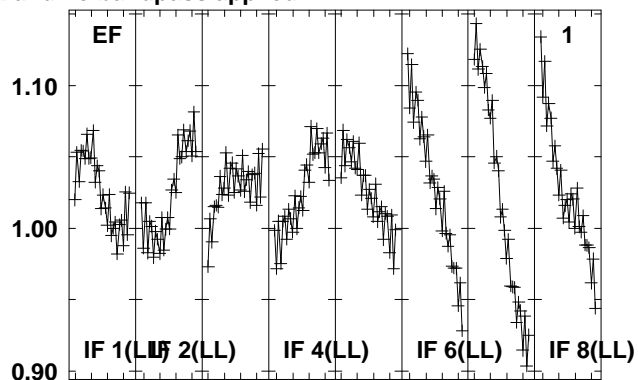
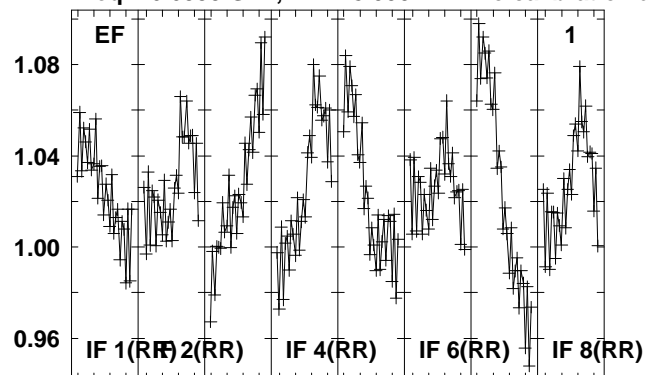

Lower frame: Real Jy
Total-power spectrum Antenna: *
Timerange: 00/10:25:27 to 00/10:26:55

Plot file version 34 created 15-MAR-2012 17:30:50

2114-G85 EZ020E 2.UVDATA.1

Freq = 6.6335 GHz, Bw = 8.000 MH No calibration applied and no bandpass applied

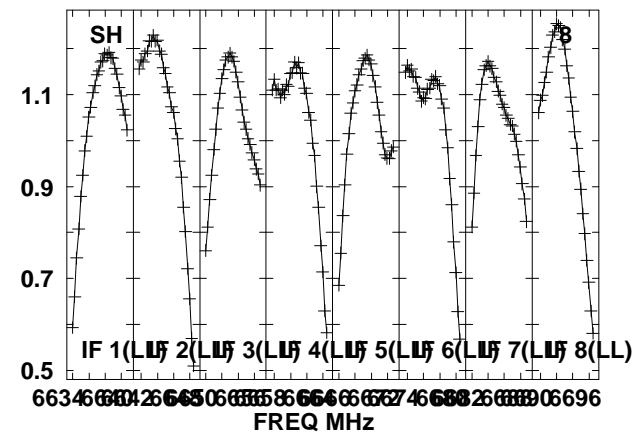
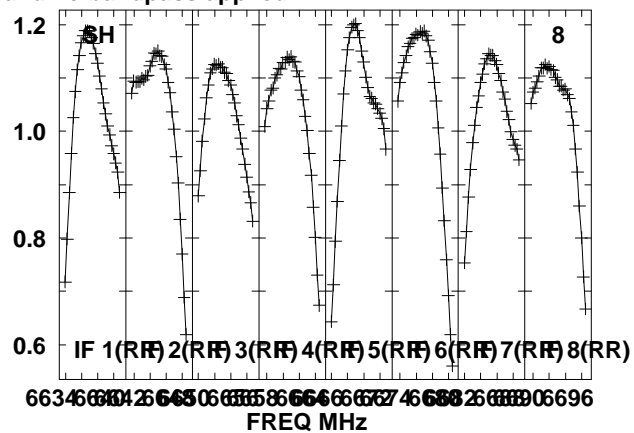
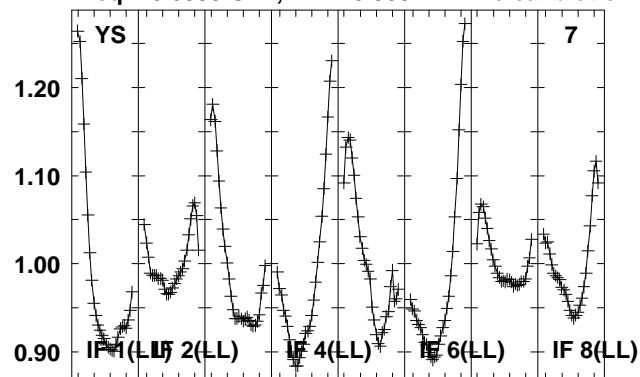

Lower frame: Real Jy
Total-power spectrum Antenna: *
Timerange: 00/10:25:27 to 00/10:26:55

Plot file version 35 created 15-MAR-2012 17:30:51

G85.40 EZ20E 2.UVDATA.1

Freq = 6.6335 GHz, Bw = 8.000 MH No calibration applied and no bandpass applied

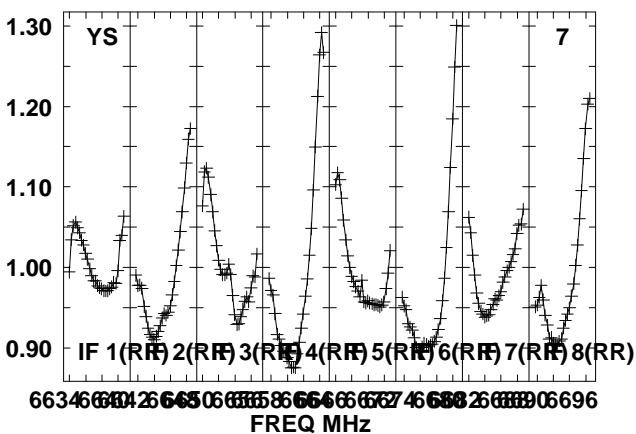
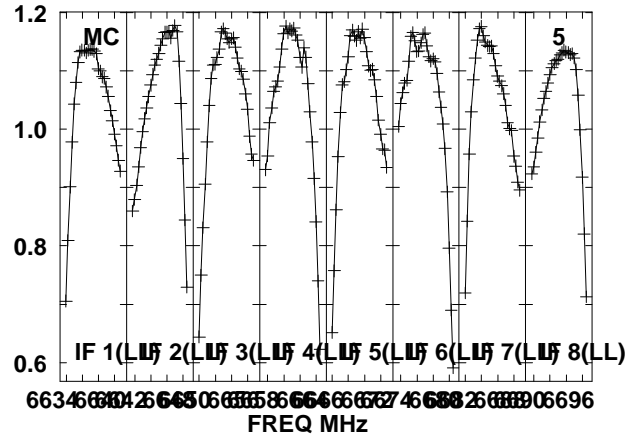
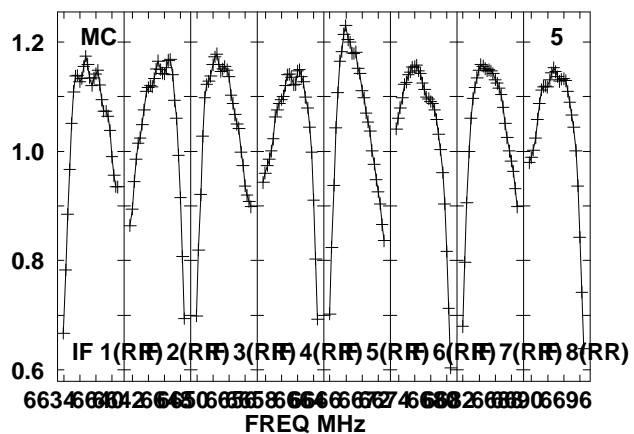
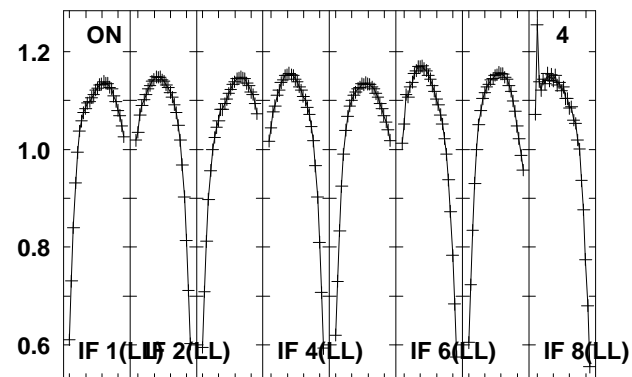
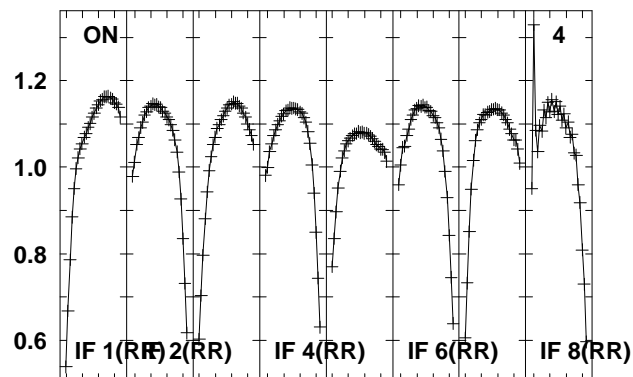
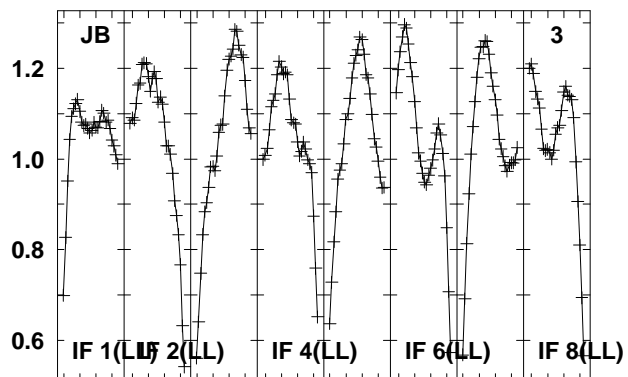
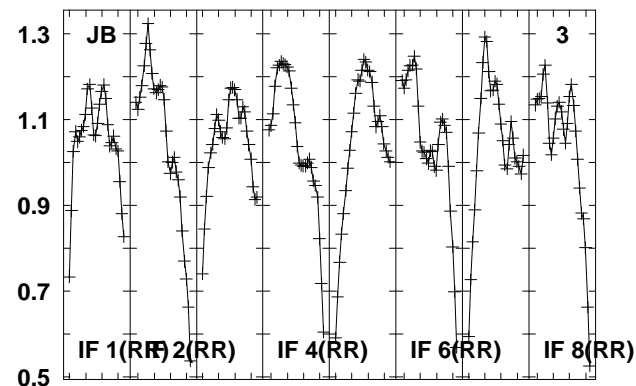
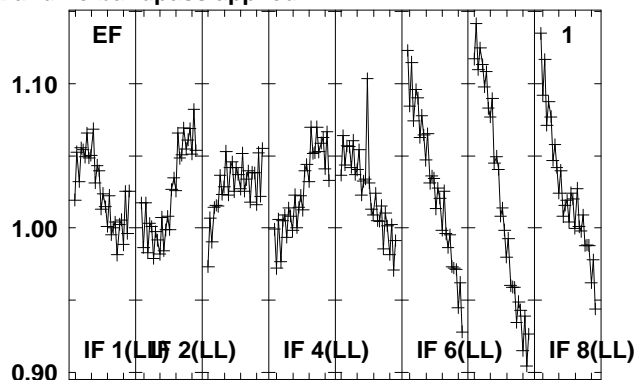
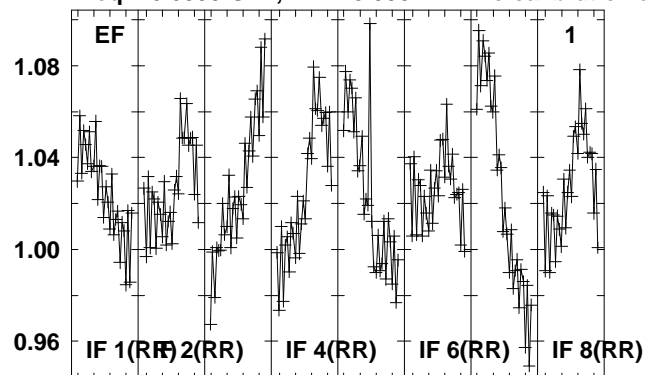

Lower frame: Real Jy
Total-power spectrum Antenna: *
Timerange: 00/10:26:57 to 00/10:28:26

Plot file version 36 created 15-MAR-2012 17:30:51

G85.40 EZ020E 2.UVDATA.1

Freq = 6.6335 GHz, Bw = 8.000 MH No calibration applied and no bandpass applied

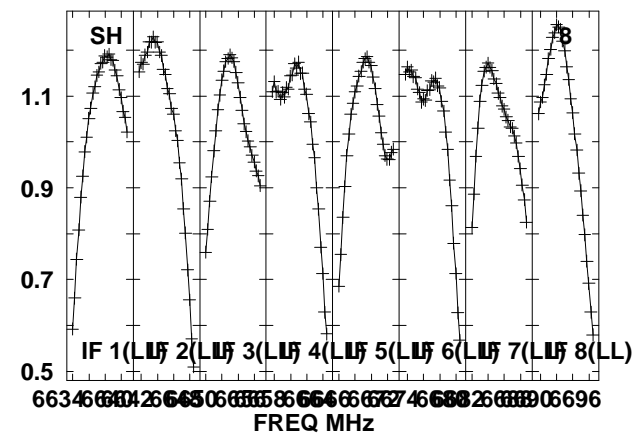
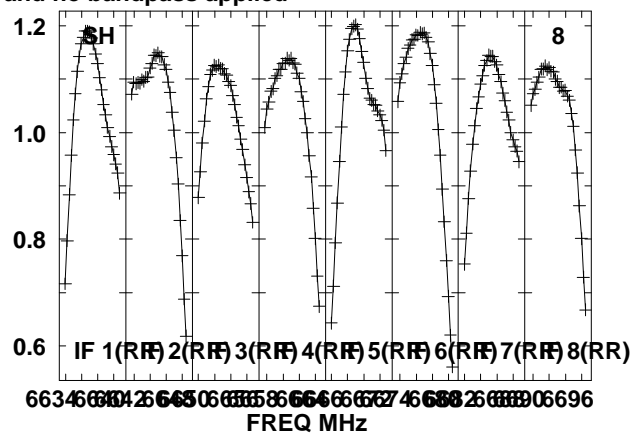
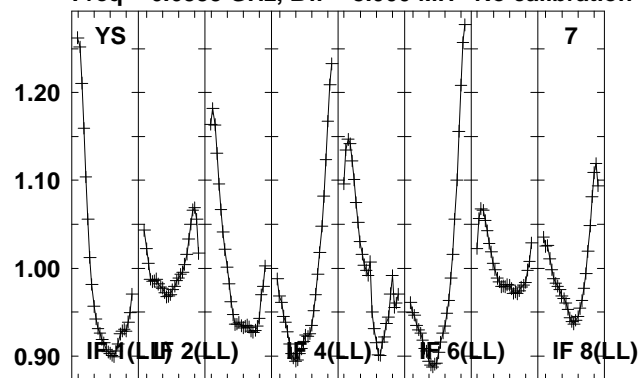

Lower frame: Real Jy
Total-power spectrum Antenna: *
Timerange: 00/10:26:57 to 00/10:28:26

Plot file version 37 created 15-MAR-2012 17:30:52

2102-G85 EZ020E 2.UVDATA.1

Freq = 6.6335 GHz, Bw = 8.000 MH No calibration applied and no bandpass applied

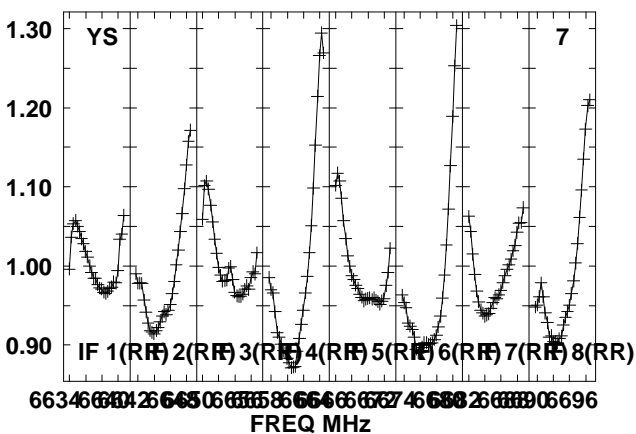
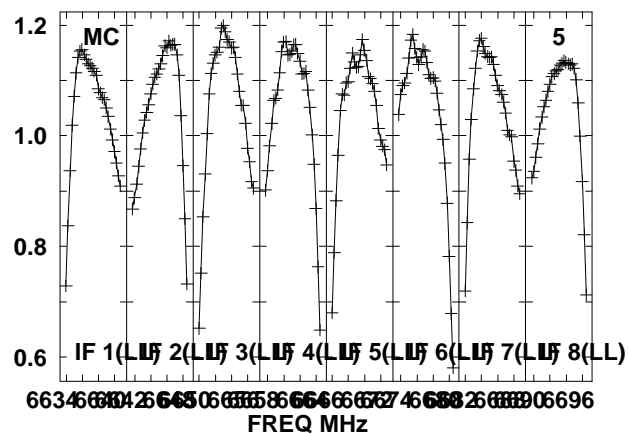
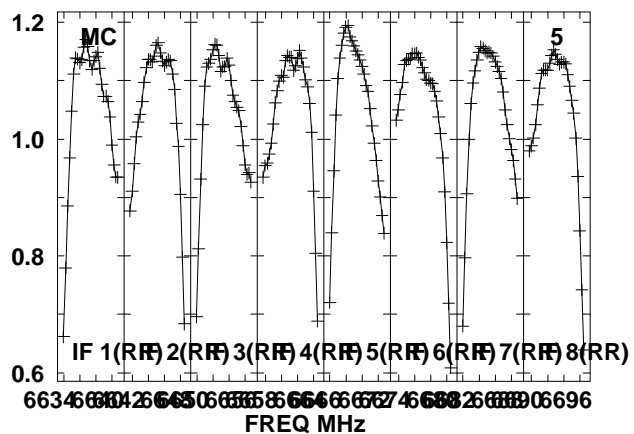
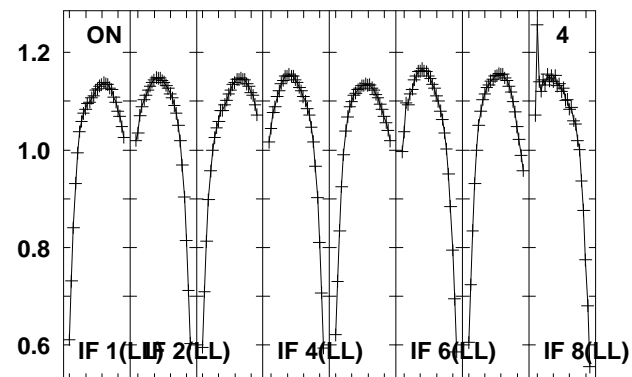
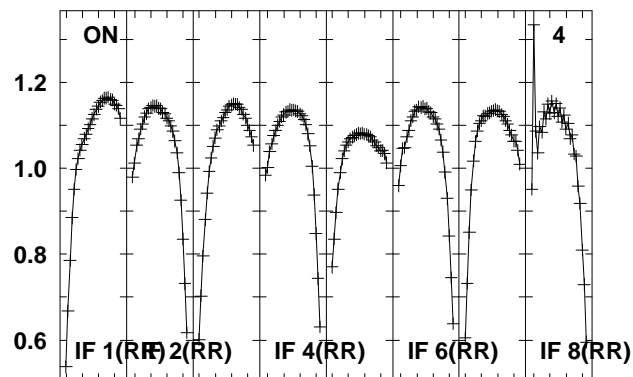
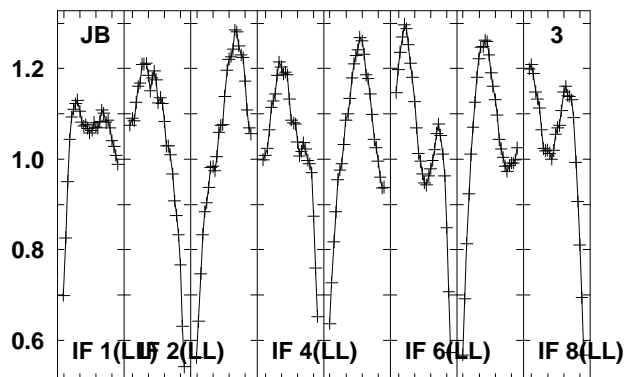
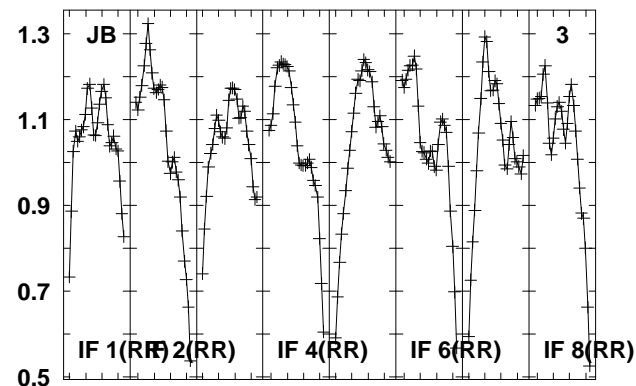
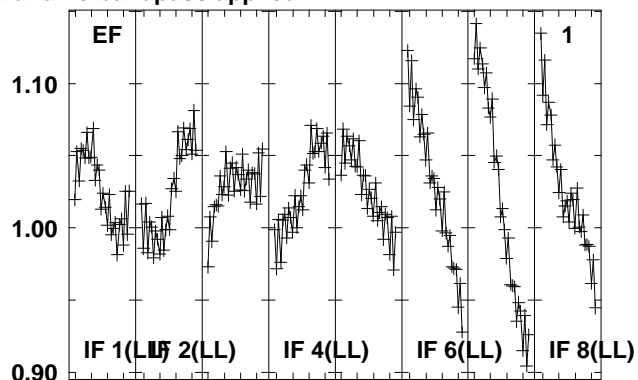
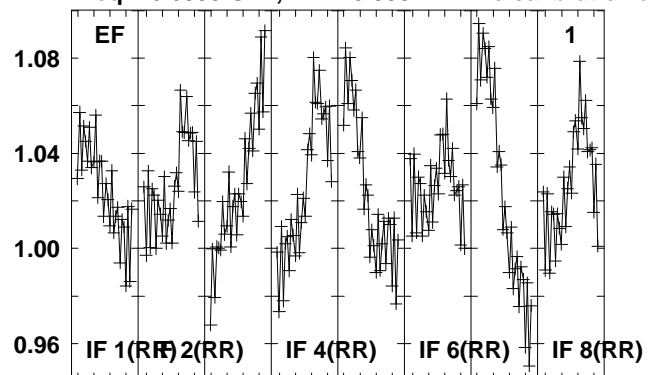

Lower frame: Real Jy
Total-power spectrum Antenna: *
Timerange: 00/10:28:27 to 00/10:29:55

Plot file version 38 created 15-MAR-2012 17:30:52

2102-G85 EZ020E 2.UVDATA.1

Freq = 6.6335 GHz, Bw = 8.000 MH No calibration applied and no bandpass applied

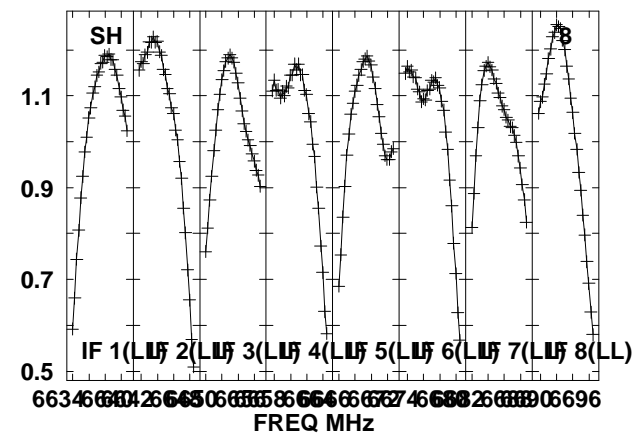
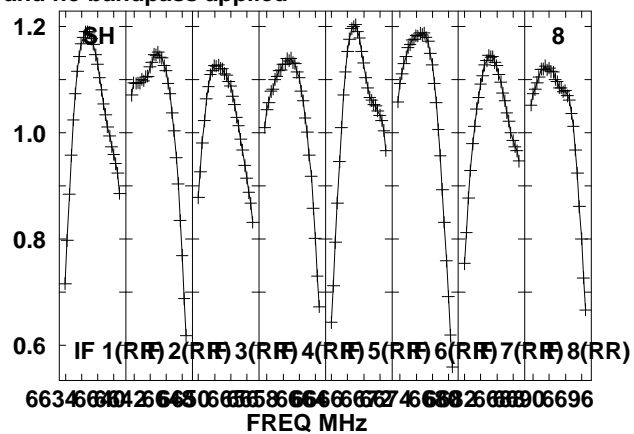
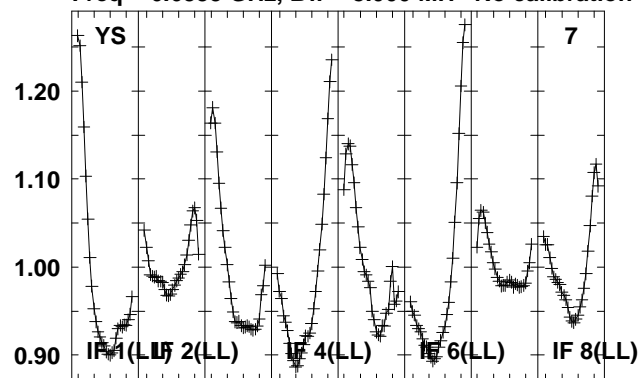

Lower frame: Real Jy
Total-power spectrum Antenna: *
Timerange: 00/10:28:27 to 00/10:29:55

Plot file version 39 created 15-MAR-2012 17:30:53

G85.40 EZ020E 2.UVDATA.1

Freq = 6.6335 GHz, Bw = 8.000 MH No calibration applied and no bandpass applied

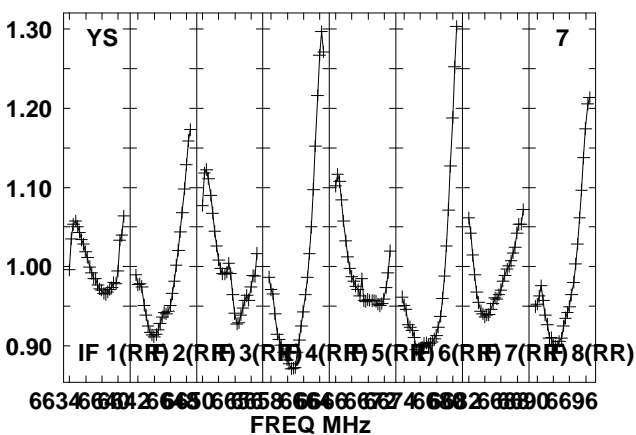
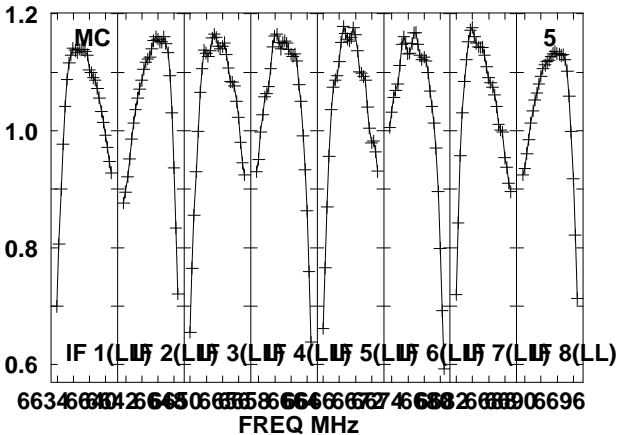
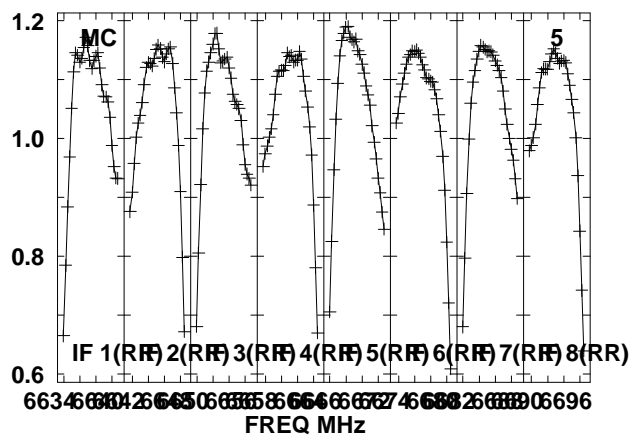
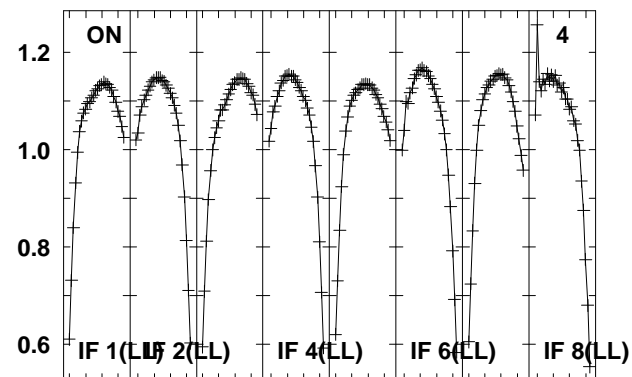
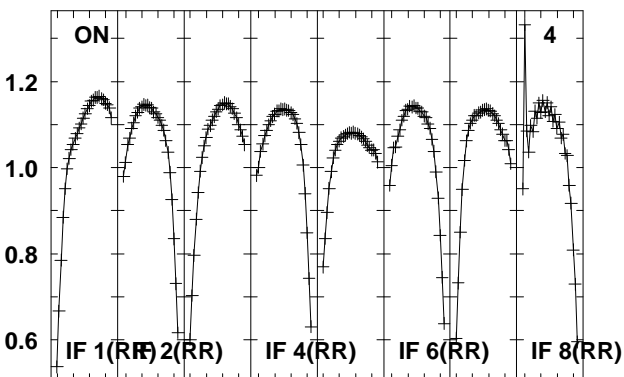
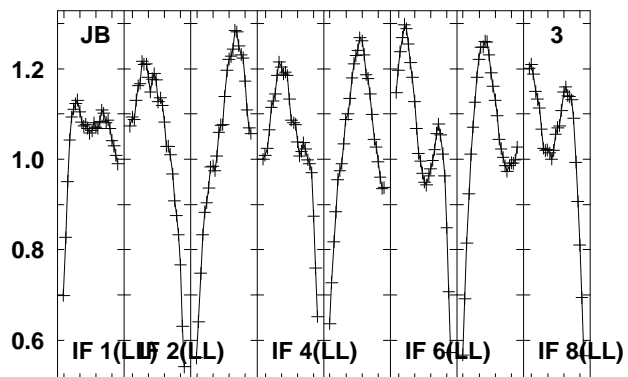
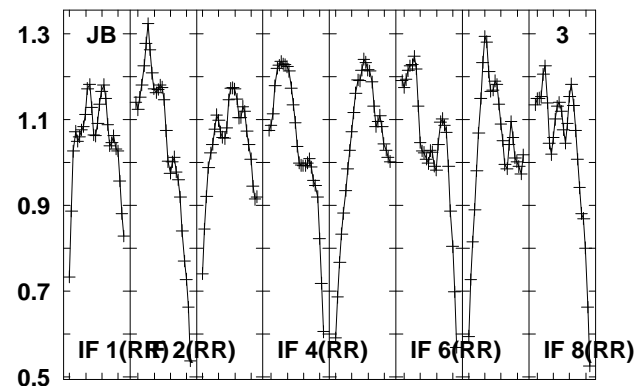
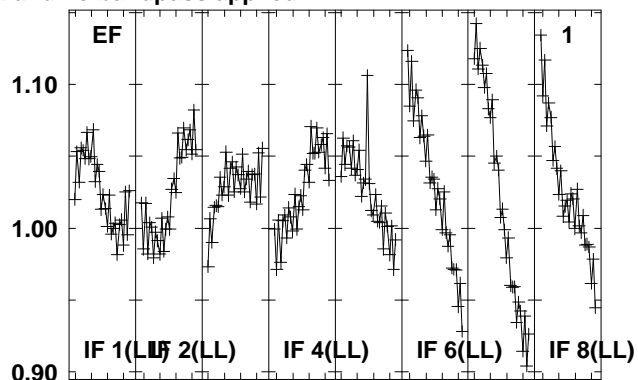
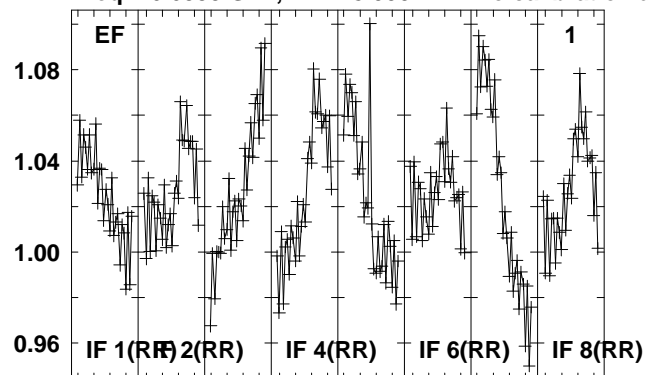

Lower frame: Real Jy
Total-power spectrum Antenna: *
Timerange: 00/10:29:57 to 00/10:31:26

Plot file version 40 created 15-MAR-2012 17:30:53

G85.40 EZ020E 2.UVDATA.1

Freq = 6.6335 GHz, Bw = 8.000 MH No calibration applied and no bandpass applied

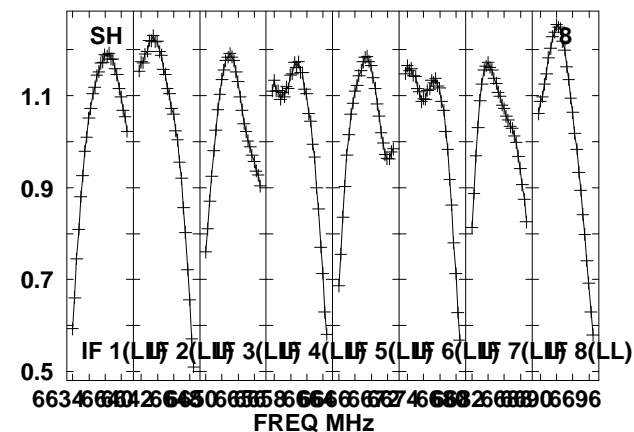
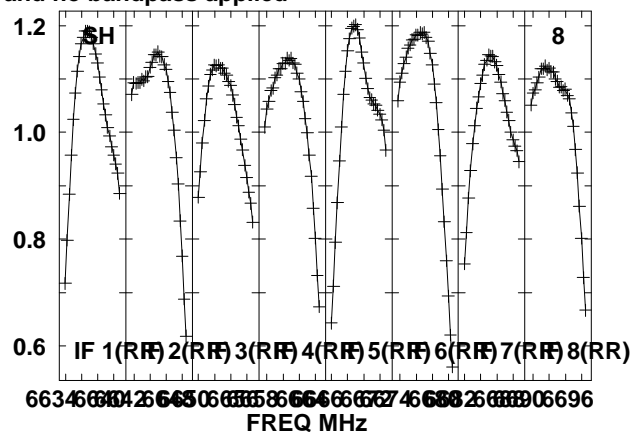
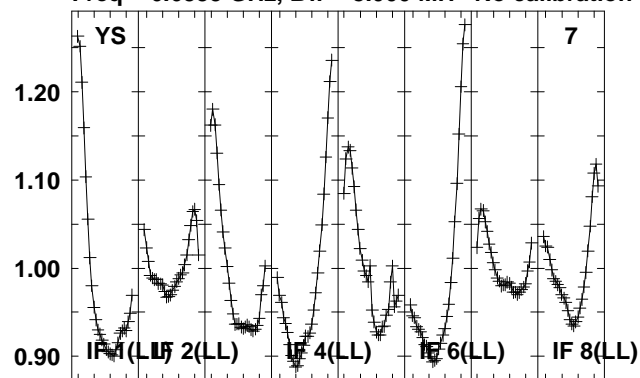

Lower frame: Real Jy
Total-power spectrum Antenna: *
Timerange: 00/10:29:57 to 00/10:31:26

Plot file version 41 created 15-MAR-2012 17:30:54

2114-G85 EZ020E 2.UVDATA.1

Freq = 6.6335 GHz, Bw = 8.000 MH No calibration applied and no bandpass applied

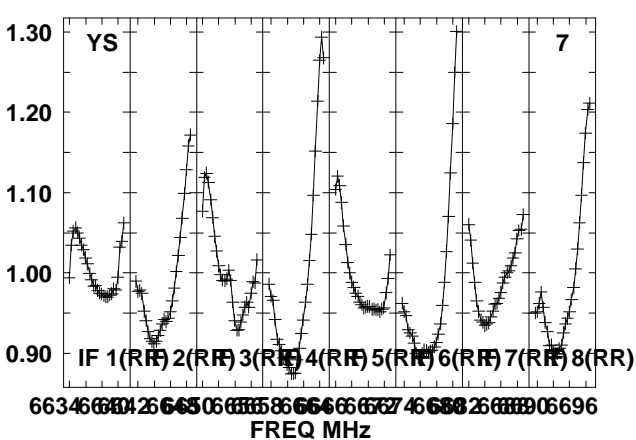
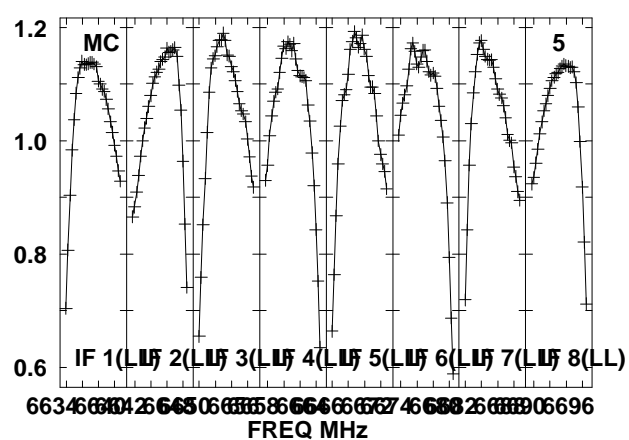
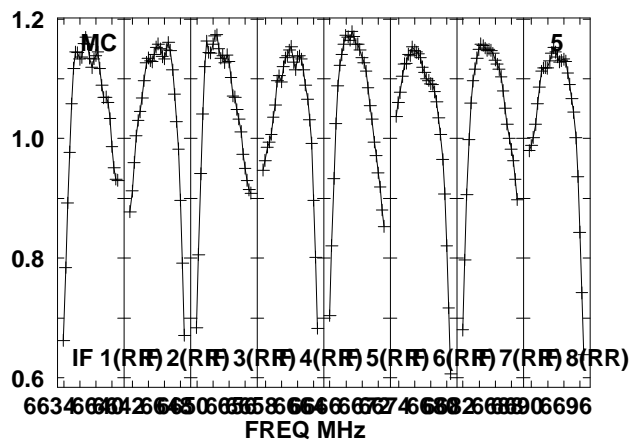
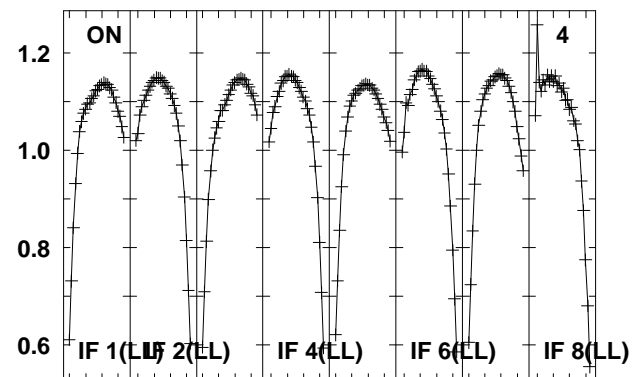
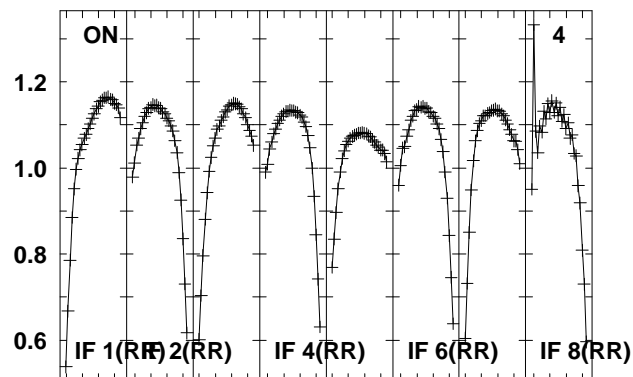
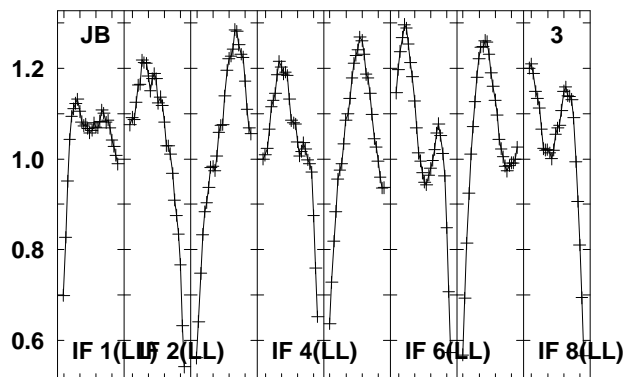
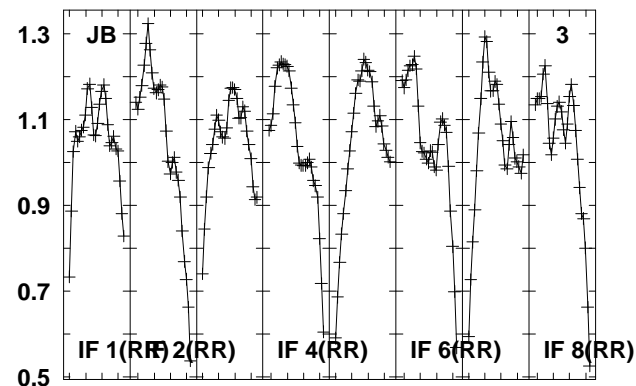
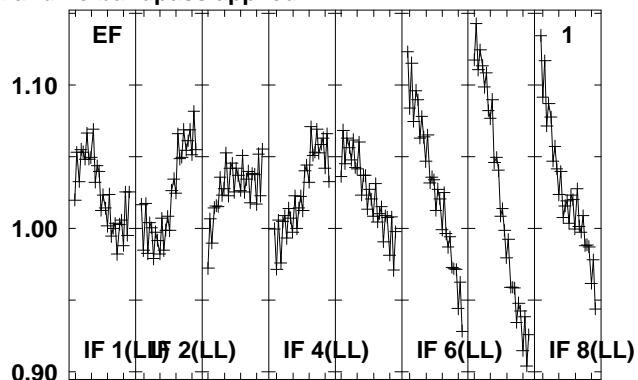
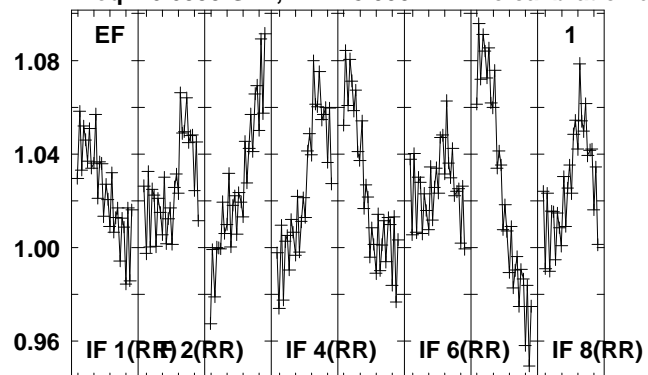

Lower frame: Real Jy
Total-power spectrum Antenna: *
Timerange: 00/10:31:28 to 00/10:32:56

Plot file version 42 created 15-MAR-2012 17:30:55

2114-G85 EZ020E 2.UVDATA.1

Freq = 6.6335 GHz, Bw = 8.000 MH No calibration applied and no bandpass applied

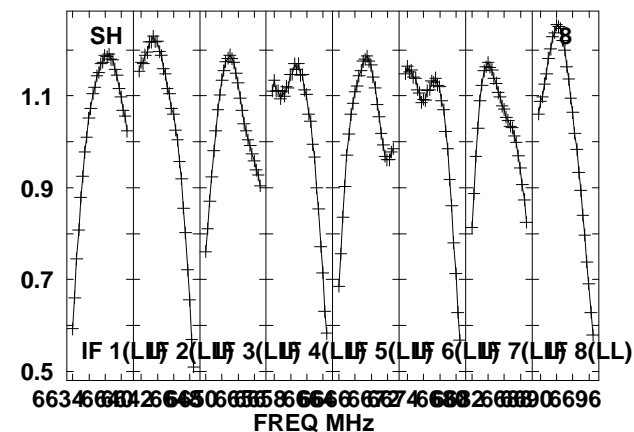
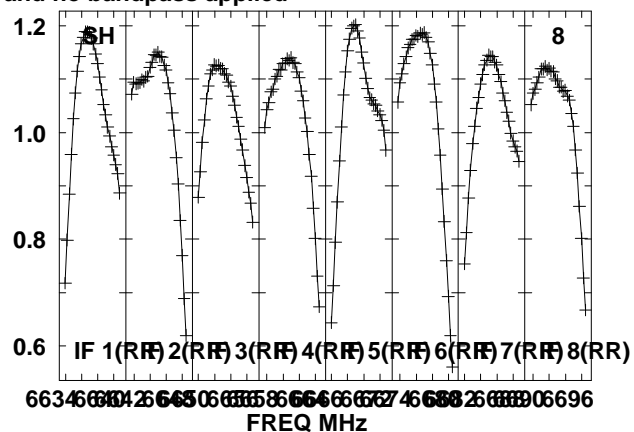
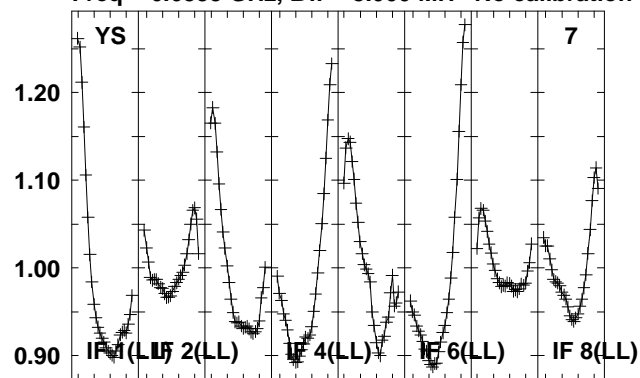

Lower frame: Real Jy
Total-power spectrum Antenna: *
Timerange: 00/10:31:28 to 00/10:32:56

Plot file version 43 created 15-MAR-2012 17:30:55

G85.40 EZ20E 2.UVDATA.1

Freq = 6.6335 GHz, Bw = 8.000 MH No calibration applied and no bandpass applied

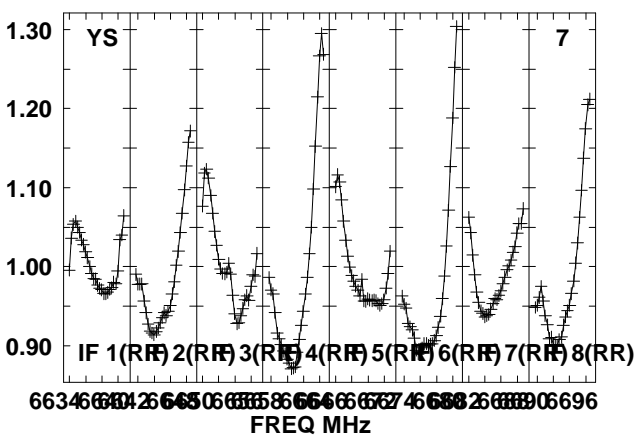
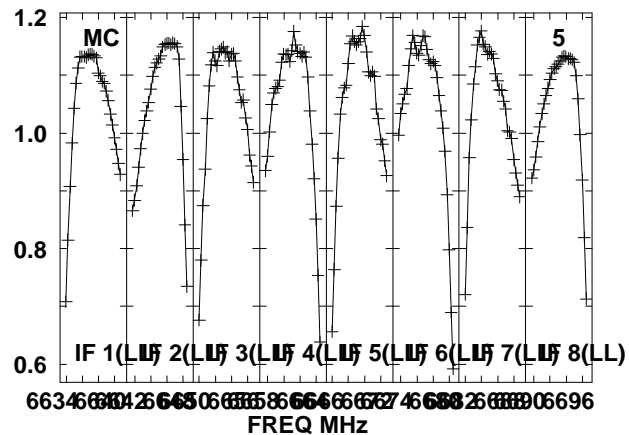
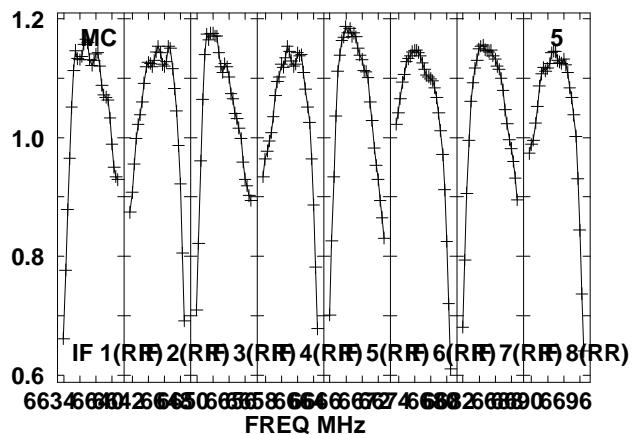
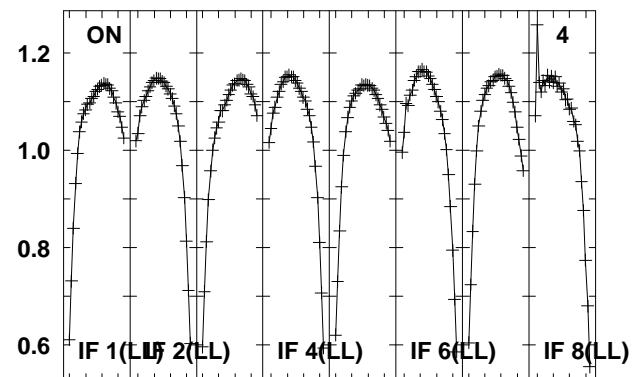
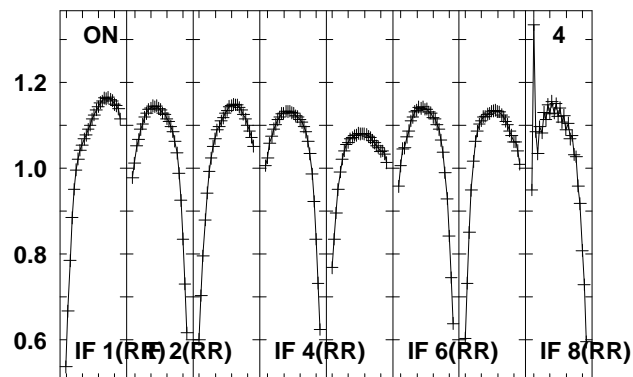
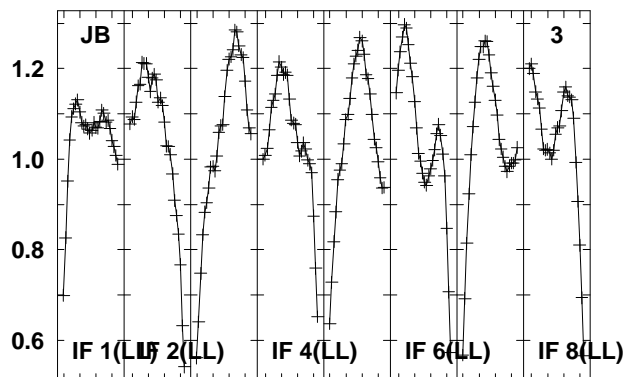
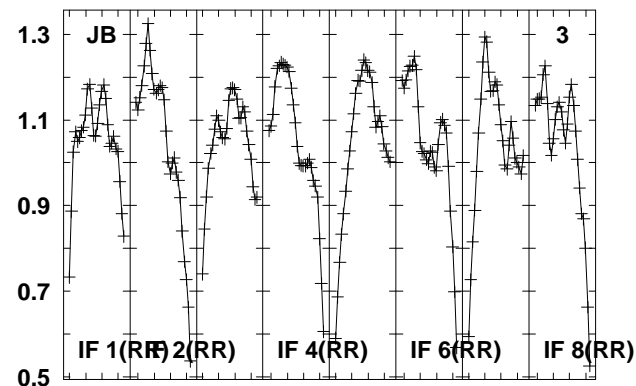
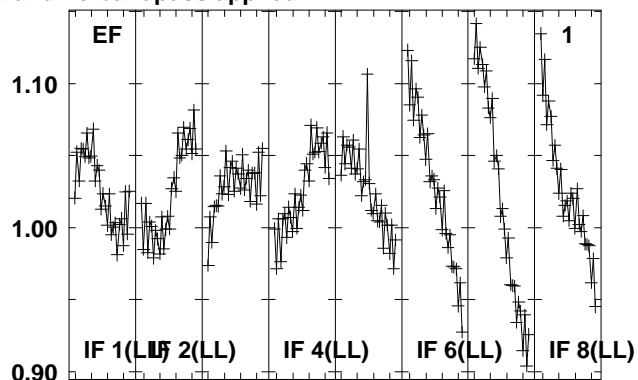
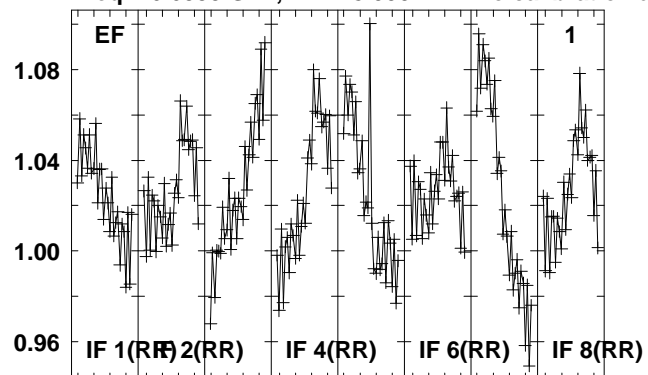

Lower frame: Real Jy
Total-power spectrum Antenna: *
Timerange: 00/10:33:36 to 00/10:34:33

Plot file version 44 created 15-MAR-2012 17:30:55

G85.40 EZ020E 2.UVDATA.1

Freq = 6.6335 GHz, Bw = 8.000 MH No calibration applied and no bandpass applied

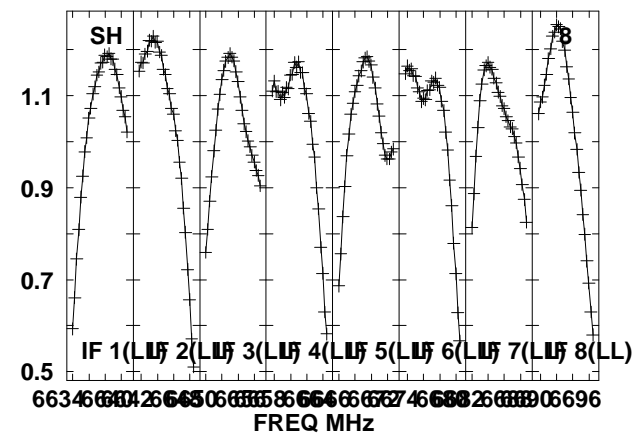
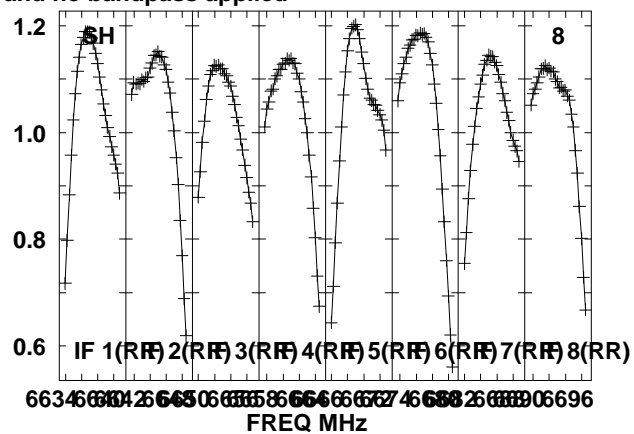
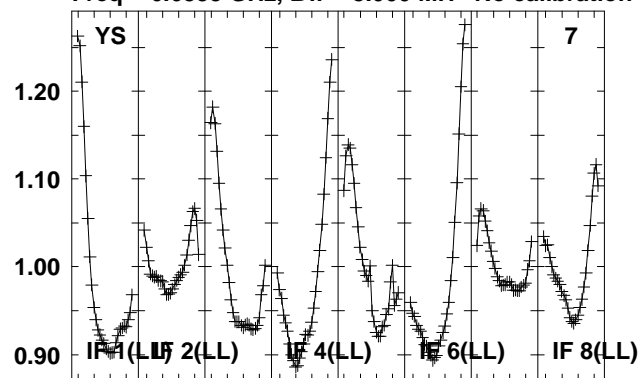

Lower frame: Real Jy
Total-power spectrum Antenna: *
Timerange: 00/10:33:36 to 00/10:34:33

Plot file version 45 created 15-MAR-2012 17:30:56

G85.40 EZ020E 2.UVDATA.1

Freq = 6.6335 GHz, Bw = 8.000 MH No calibration applied and no bandpass applied

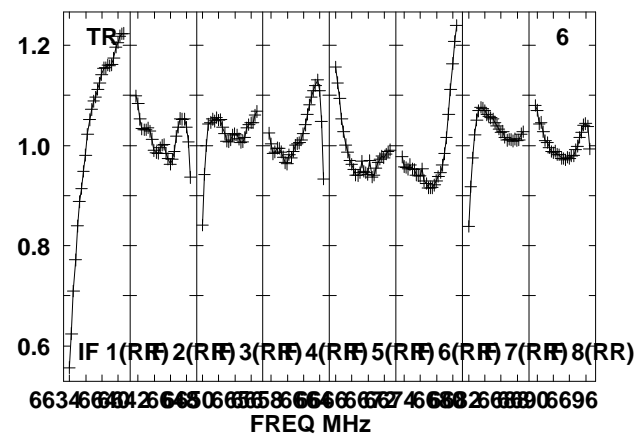
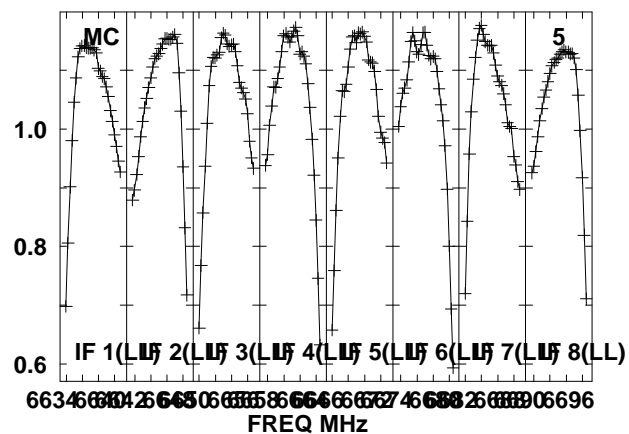
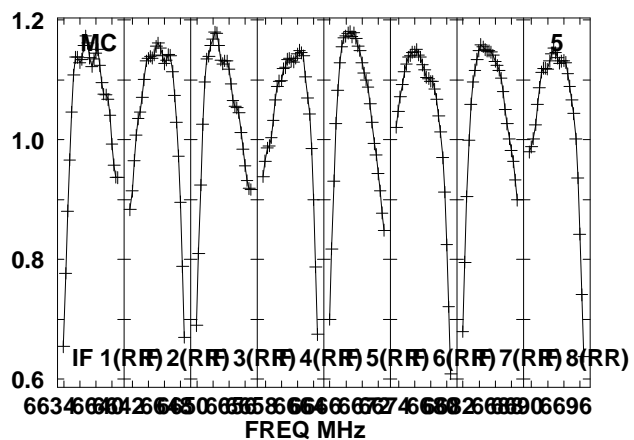
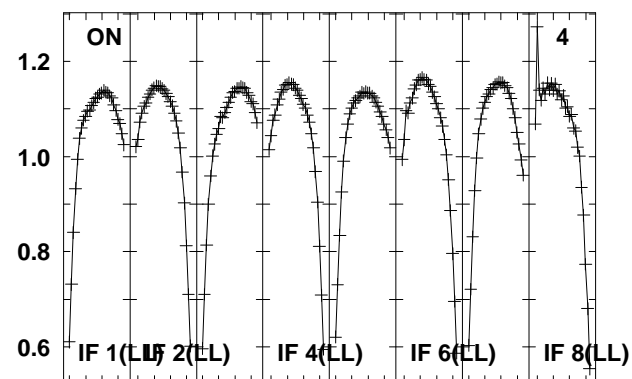
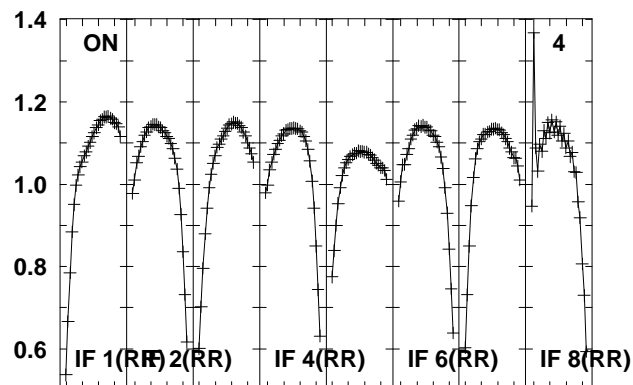
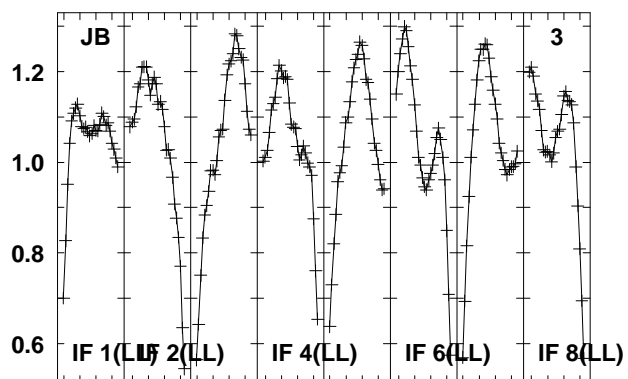
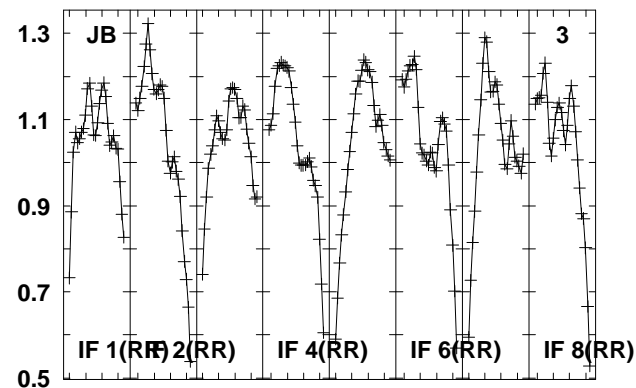
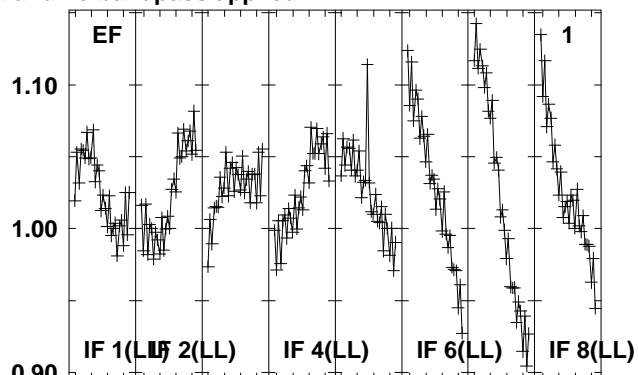
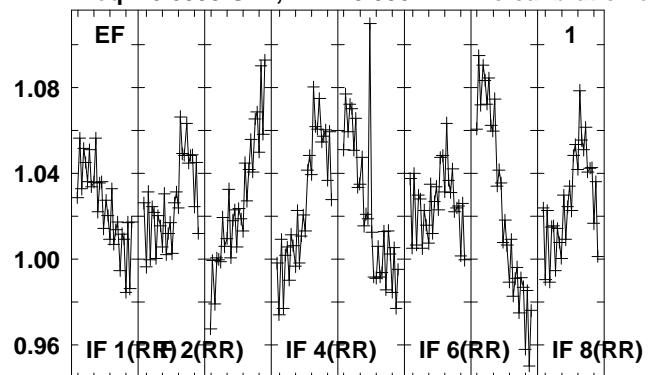

Lower frame: Real Jy
Total-power spectrum Antenna: *
Timerange: 00/11:07:21 to 00/11:08:19

Plot file version 46 created 15-MAR-2012 17:30:56

G85.40 EZ020E 2.UVDATA.1

Freq = 6.6335 GHz, Bw = 8.000 MH No calibration applied and no bandpass applied

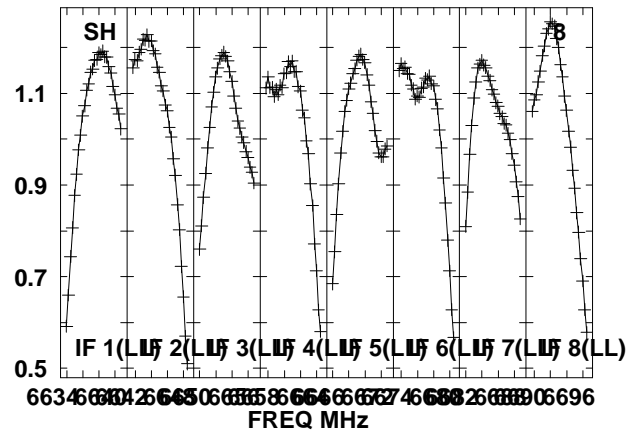
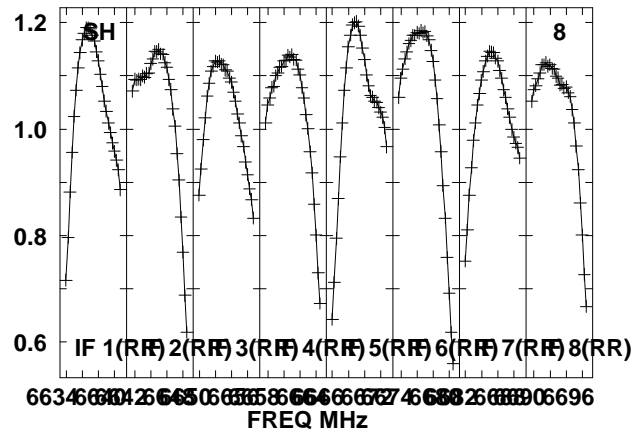
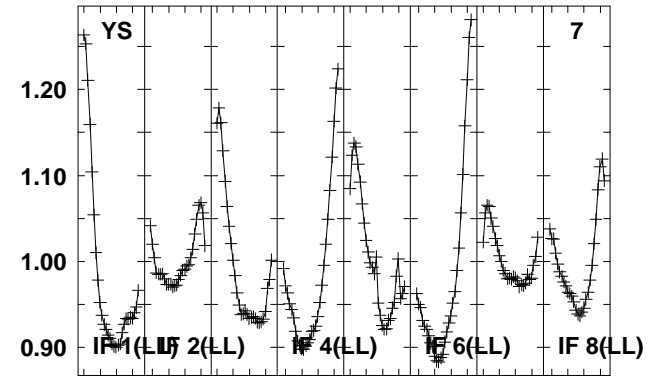
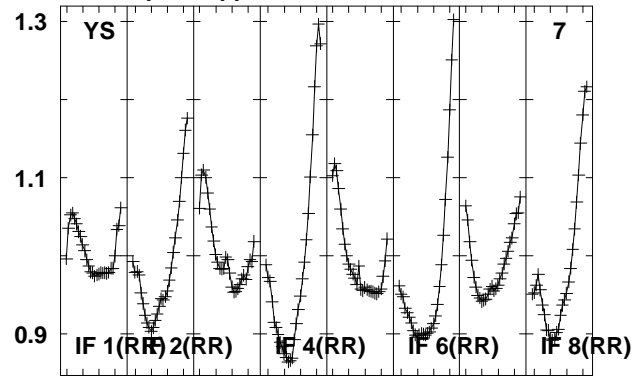
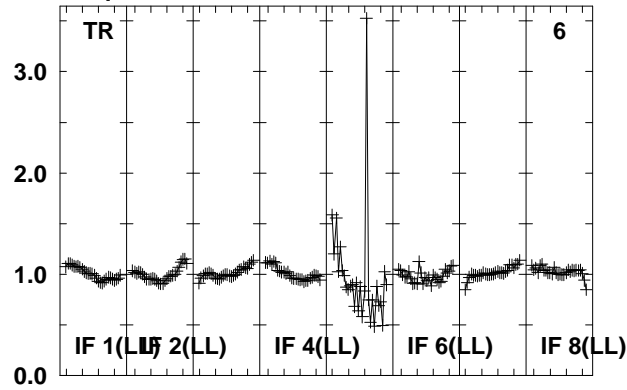

Lower frame: Real Jy
Total-power spectrum Antenna: *
Timerange: 00/11:07:21 to 00/11:08:19

Plot file version 47 created 15-MAR-2012 17:30:57

2102-G85 EZ020E 2.UVDATA.1

Freq = 6.6335 GHz, Bw = 8.000 MH No calibration applied and no bandpass applied

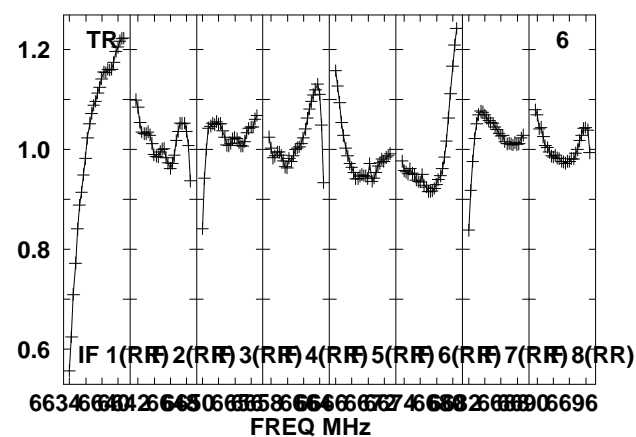
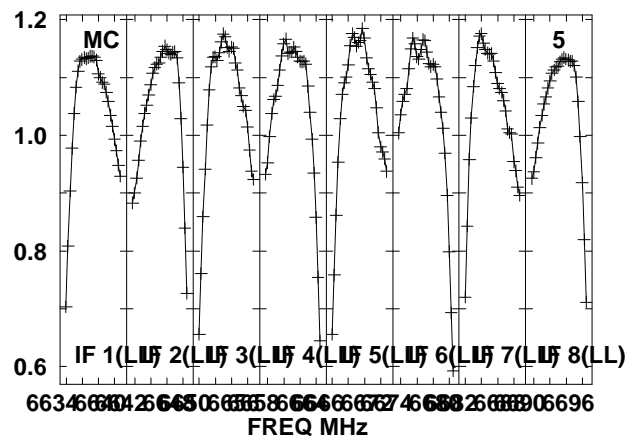
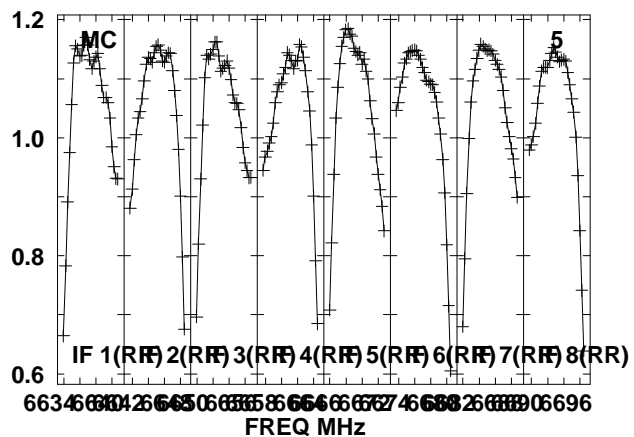
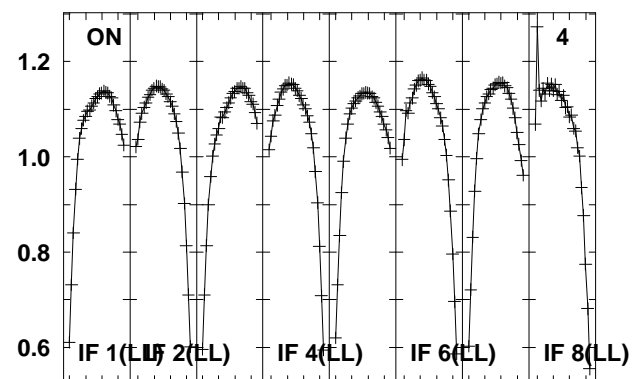
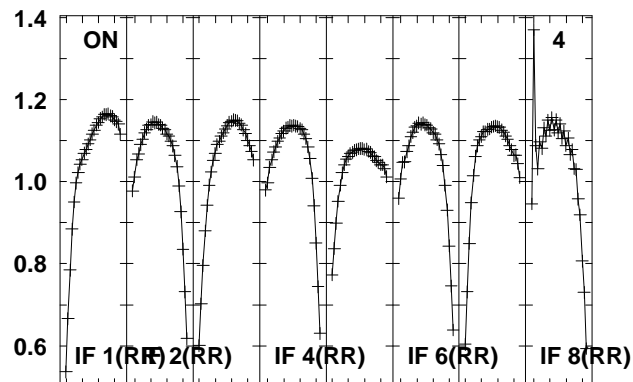
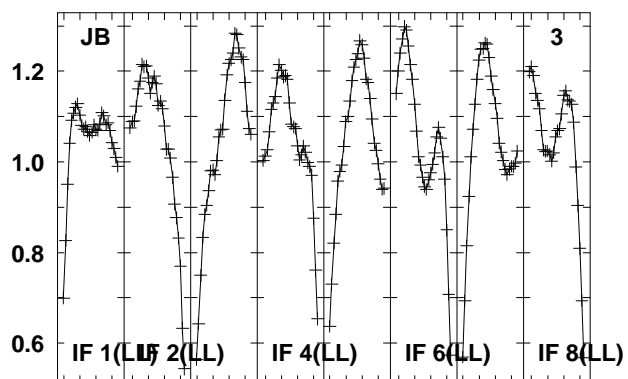
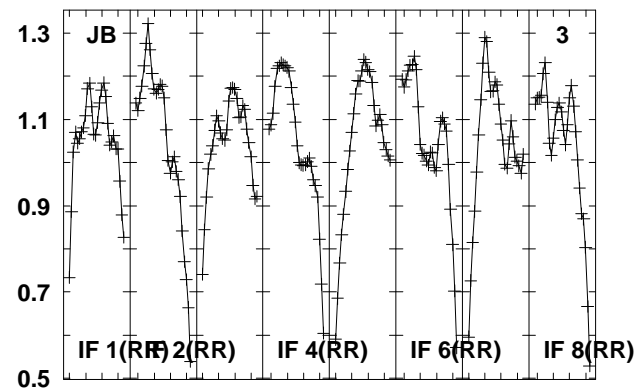
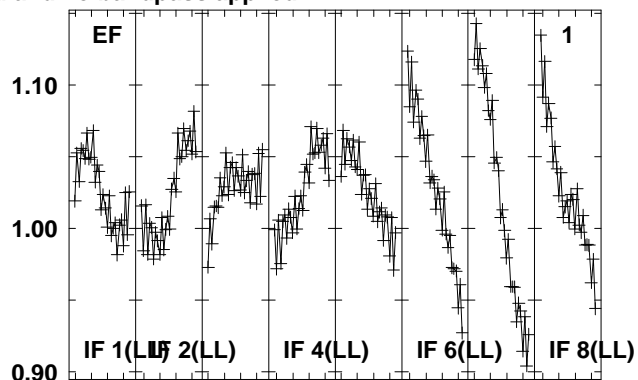
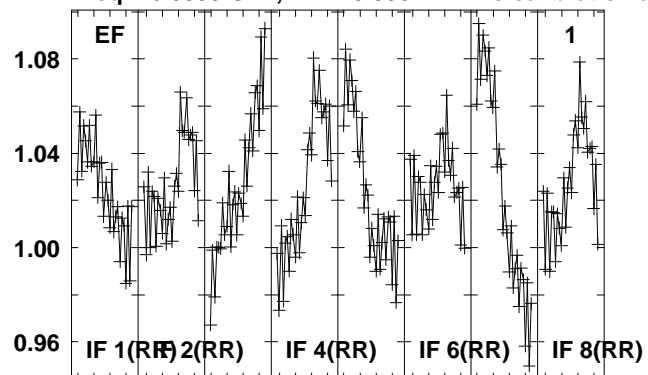

Lower frame: Real Jy
Total-power spectrum Antenna: *
Timerange: 00/11:08:22 to 00/11:09:50

Plot file version 48 created 15-MAR-2012 17:30:58

2102-G85 EZ020E 2.UVDATA.1

Freq = 6.6335 GHz, Bw = 8.000 MH No calibration applied and no bandpass applied

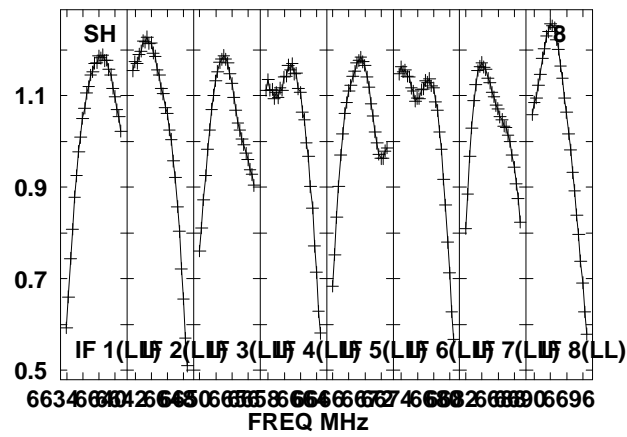
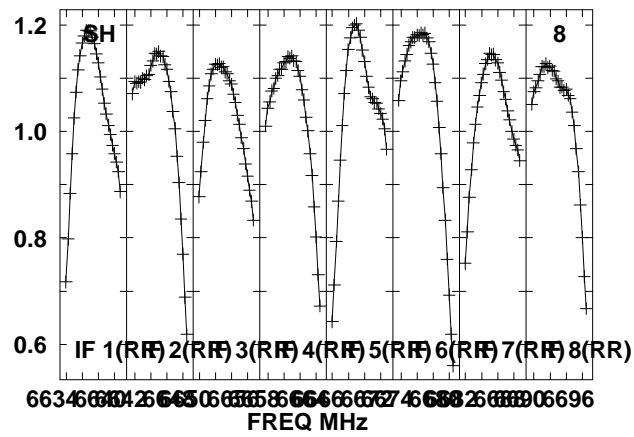
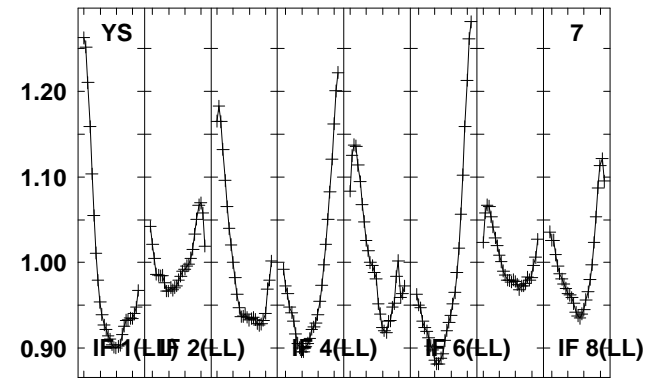
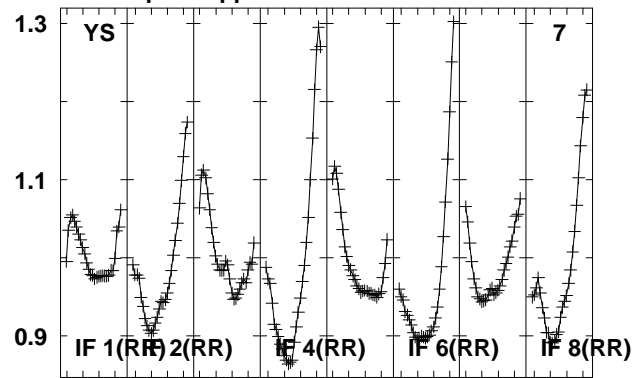
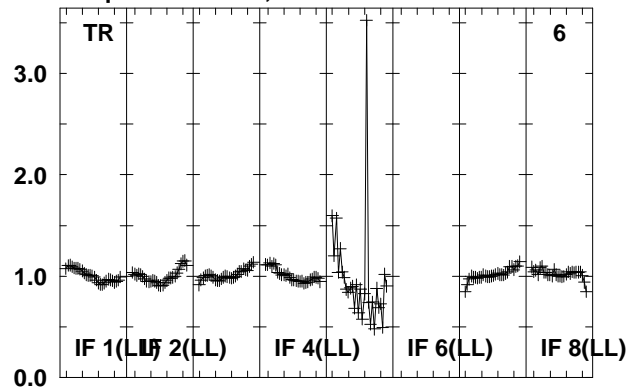

Lower frame: Real Jy
Total-power spectrum Antenna: *
Timerange: 00/11:08:22 to 00/11:09:50

Plot file version 49 created 15-MAR-2012 17:30:58

G85.40 EZ020E 2.UVDATA.1

Freq = 6.6335 GHz, Bw = 8.000 MH No calibration applied and no bandpass applied

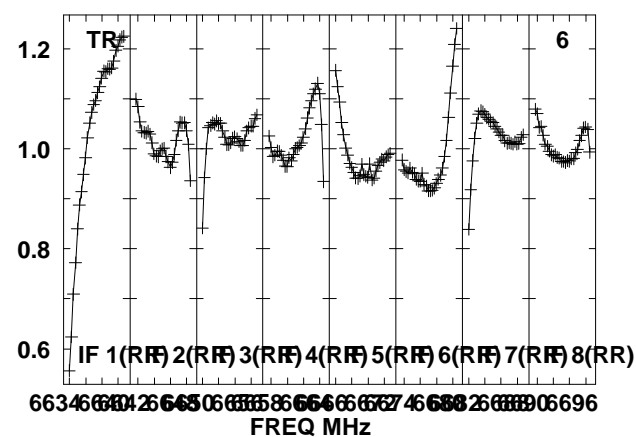
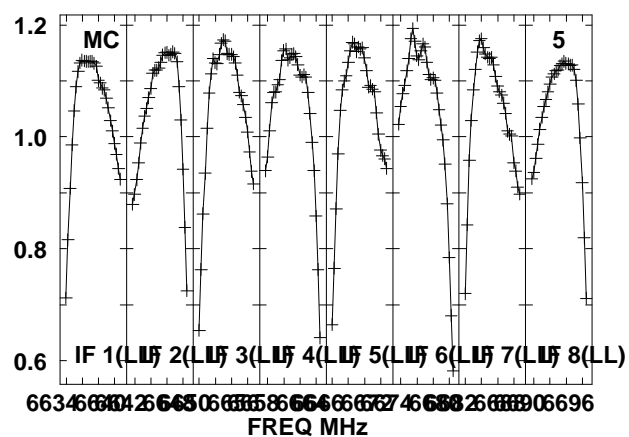
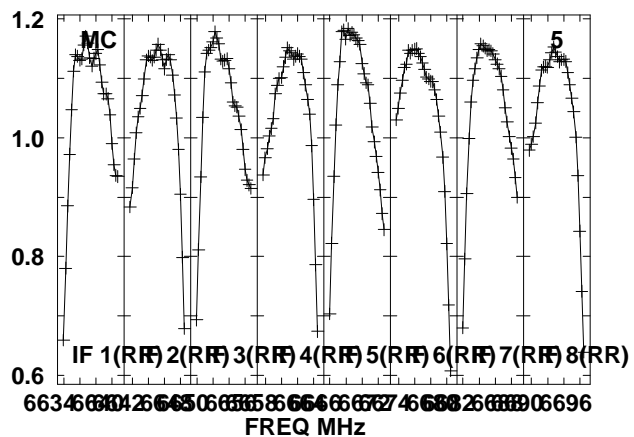
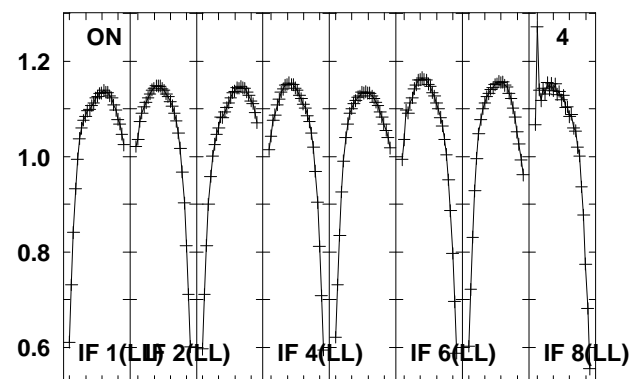
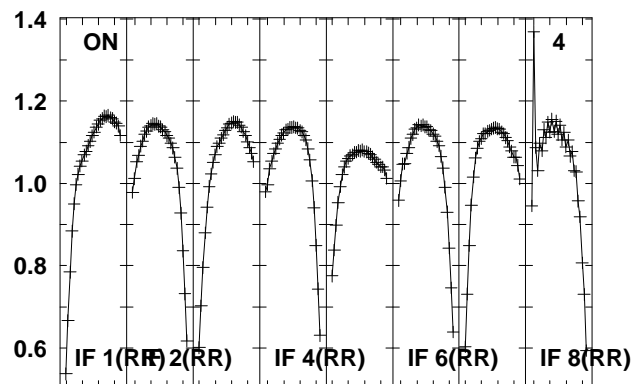
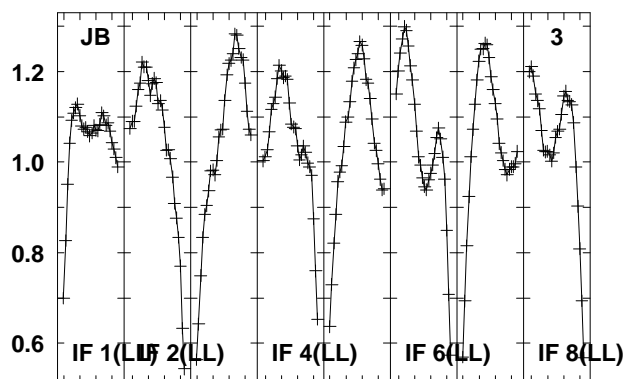
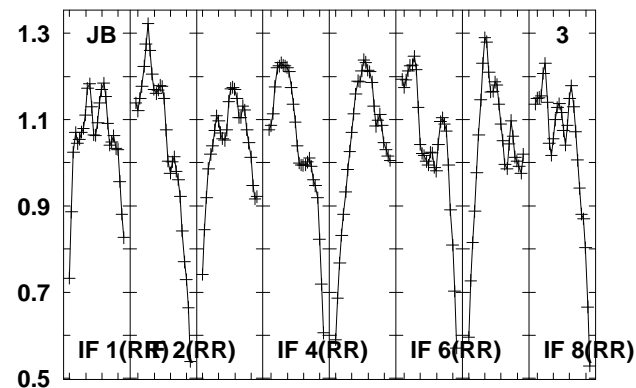
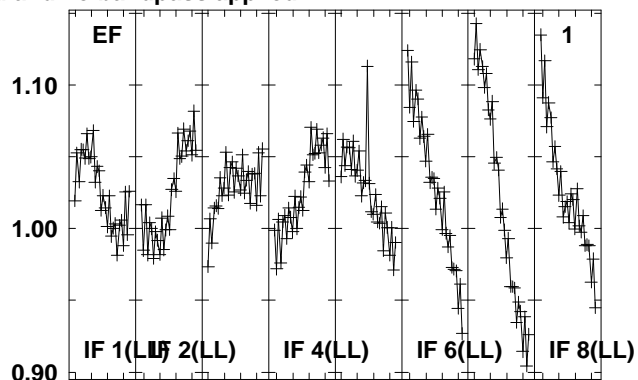
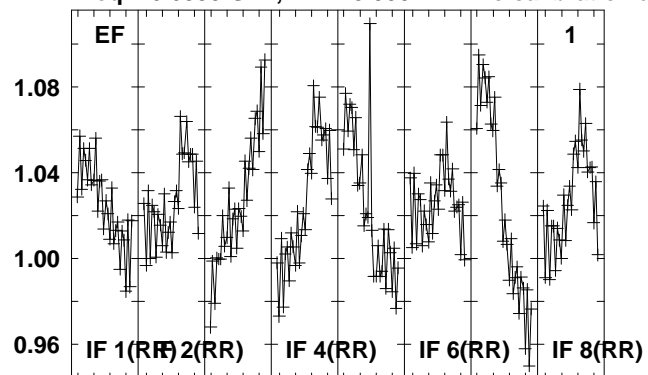

Lower frame: Real Jy
Total-power spectrum Antenna: *
Timerange: 00/11:09:51 to 00/11:11:19

Plot file version 50 created 15-MAR-2012 17:30:59

G85.40 EZ020E 2.UVDATA.1

Freq = 6.6335 GHz, Bw = 8.000 MH No calibration applied and no bandpass applied

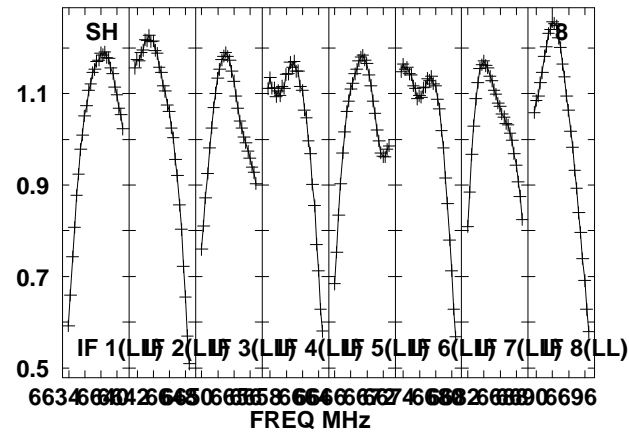
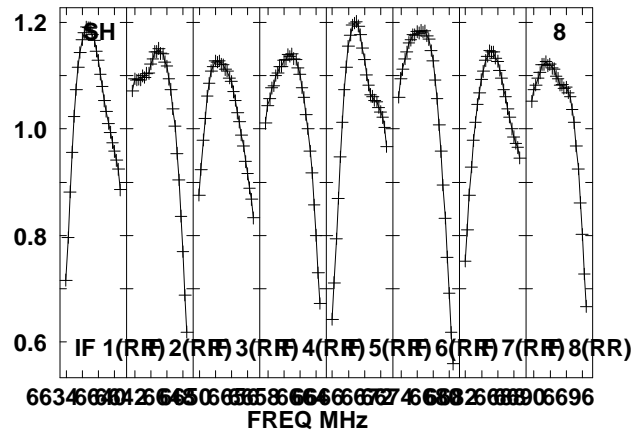
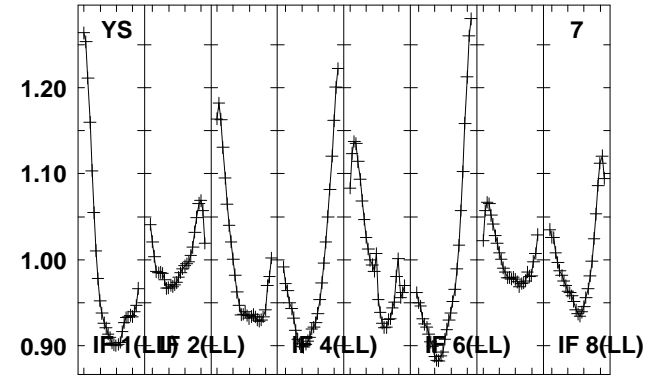
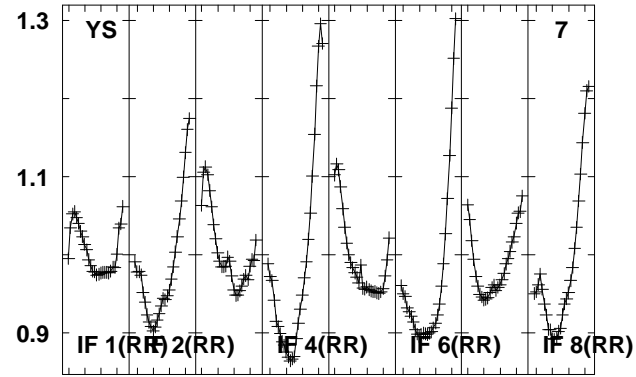
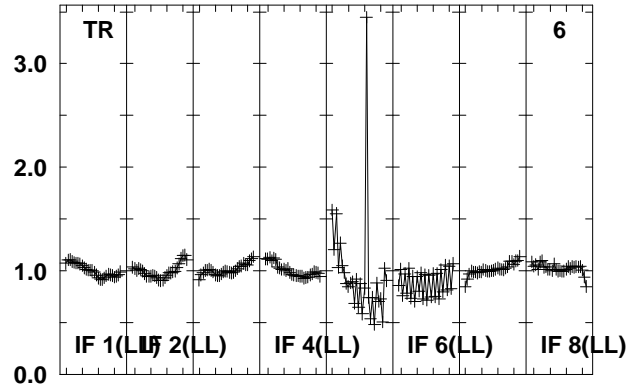

Lower frame: Real Jy
Total-power spectrum Antenna: *
Timerange: 00/11:09:51 to 00/11:11:19

Plot file version 51 created 15-MAR-2012 17:31:00
 2114-G85 EZ020E 2.UVDATA.1
 Freq = 6.6335 GHz, Bw = 8.000 MH No calibration applied and no bandpass applied

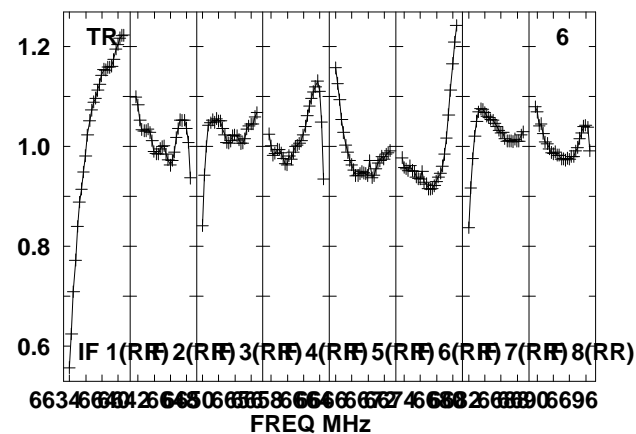
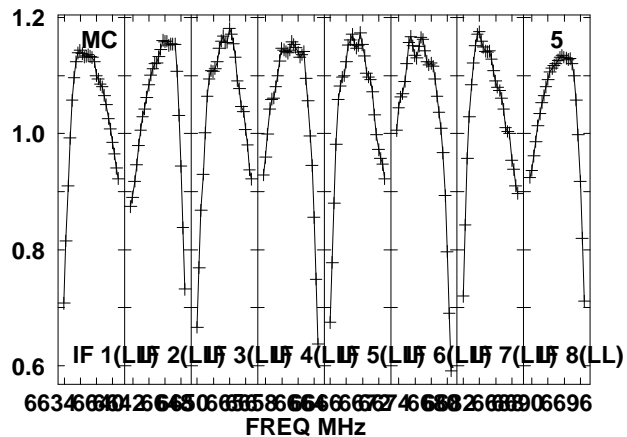
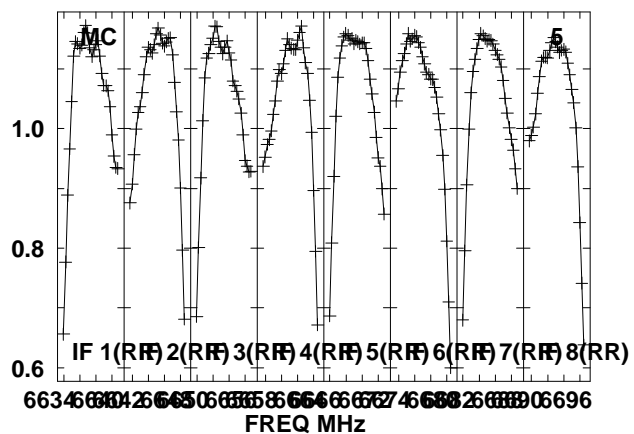
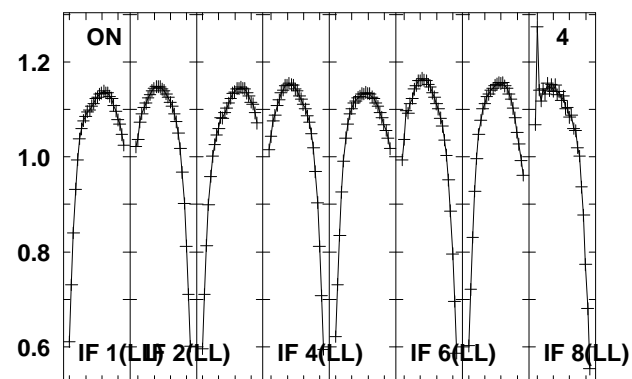
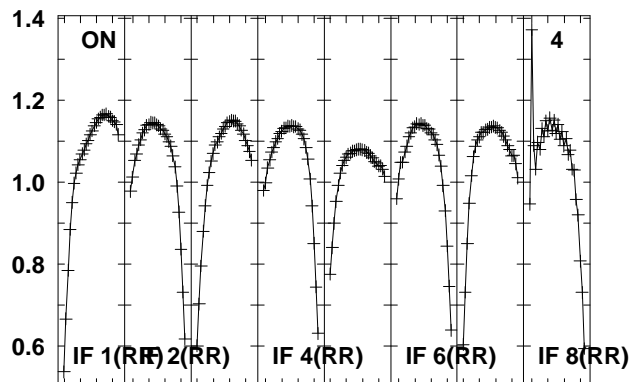
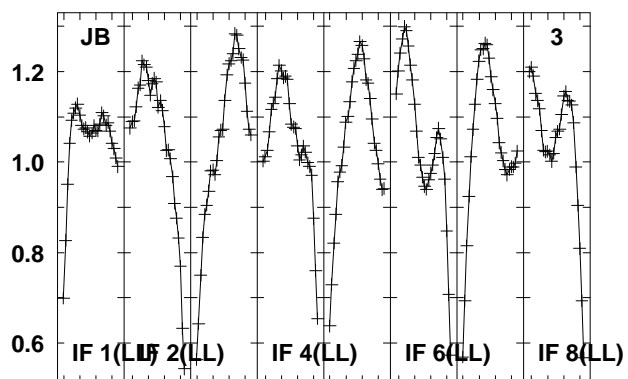
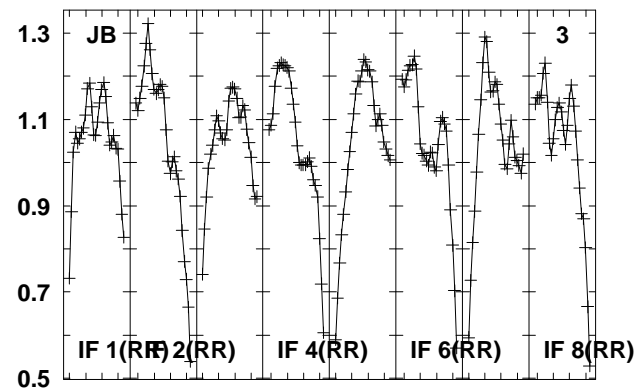
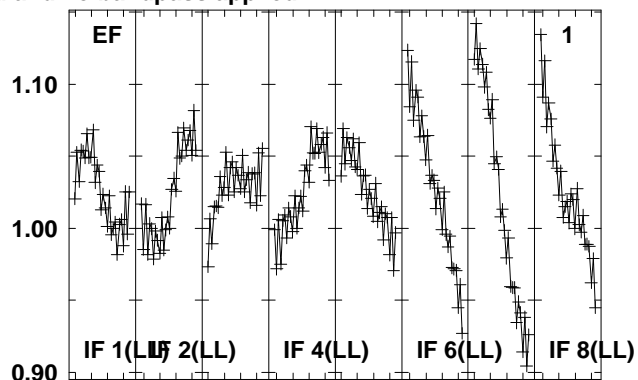
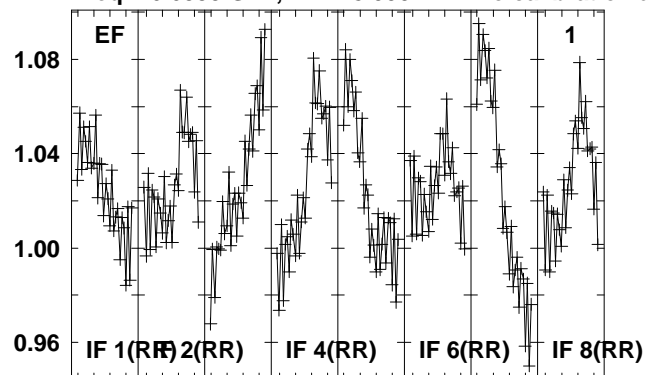

Lower frame: Real Jy
 Total-power spectrum Antenna: *
 Timerange: 00/11:11:21 to 00/11:12:50

Plot file version 52 created 15-MAR-2012 17:31:01

2114-G85 EZ020E 2.UVDATA.1

Freq = 6.6335 GHz, Bw = 8.000 MH No calibration applied and no bandpass applied

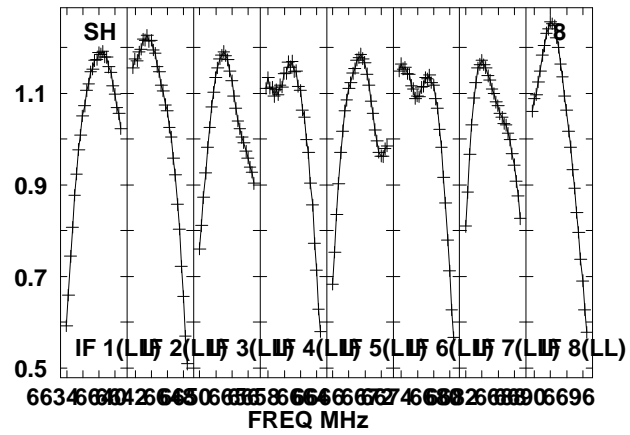
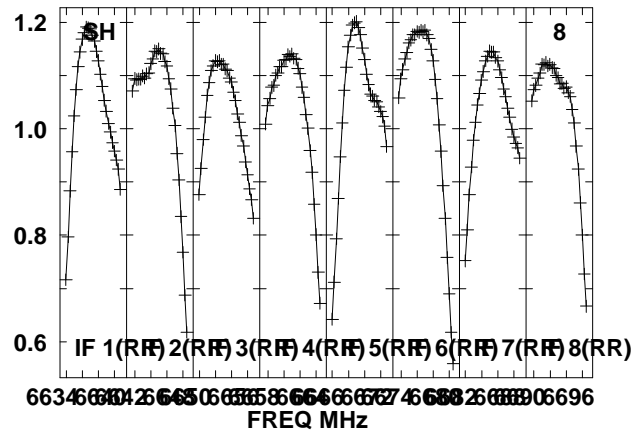
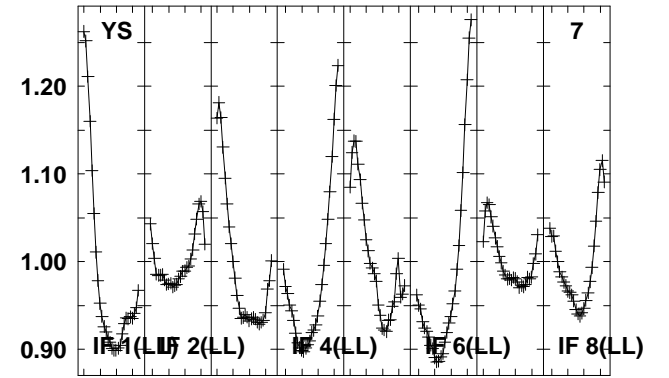
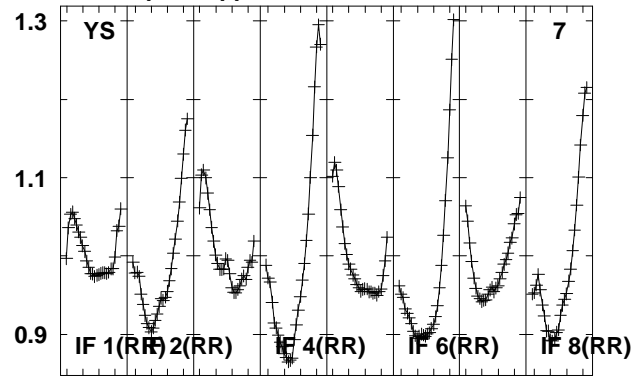
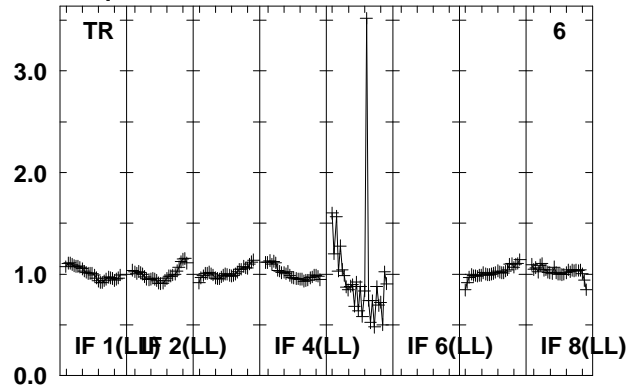

Lower frame: Real Jy
Total-power spectrum Antenna: *
Timerange: 00/11:11:21 to 00/11:12:50

Plot file version 53 created 15-MAR-2012 17:31:02

G85.40 EZ20E 2.UVDATA.1

Freq = 6.6335 GHz, Bw = 8.000 MH No calibration applied and no bandpass applied

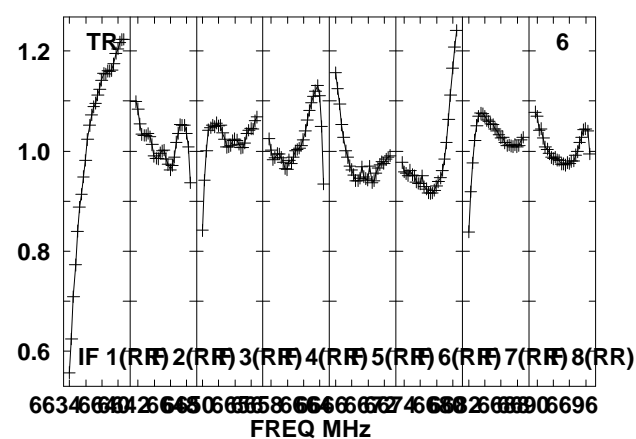
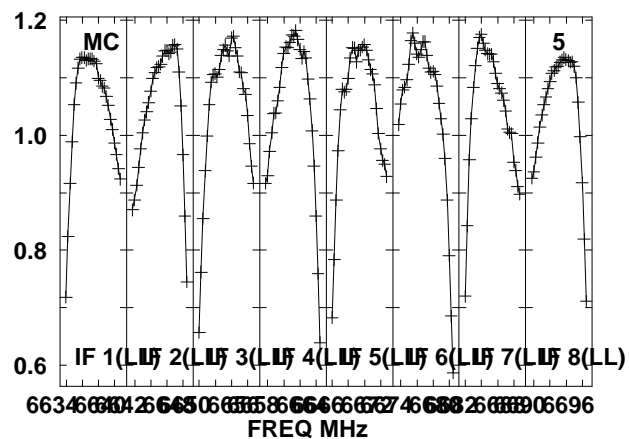
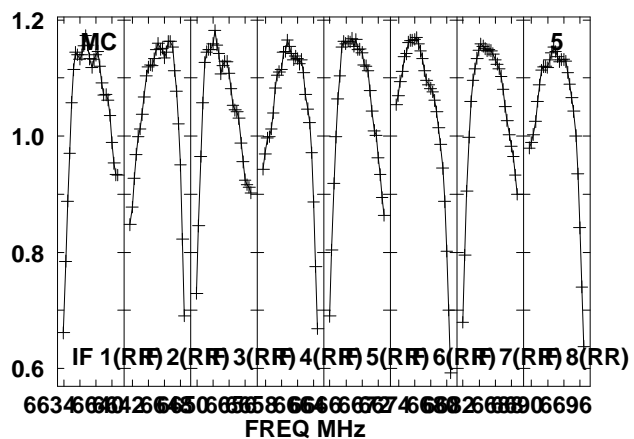
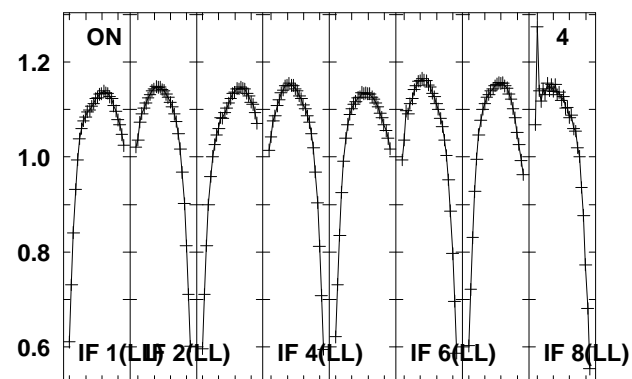
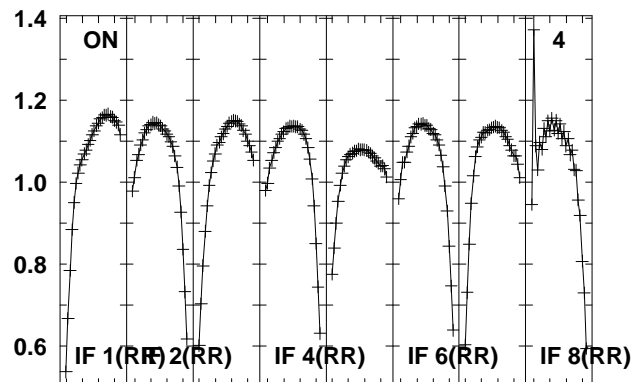
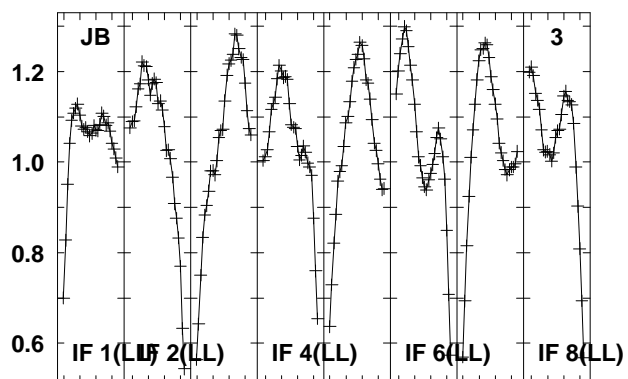
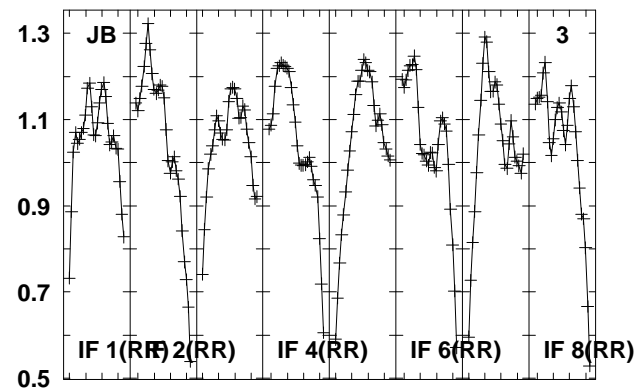
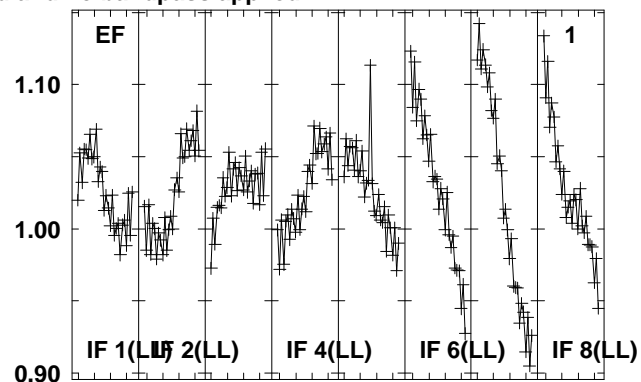
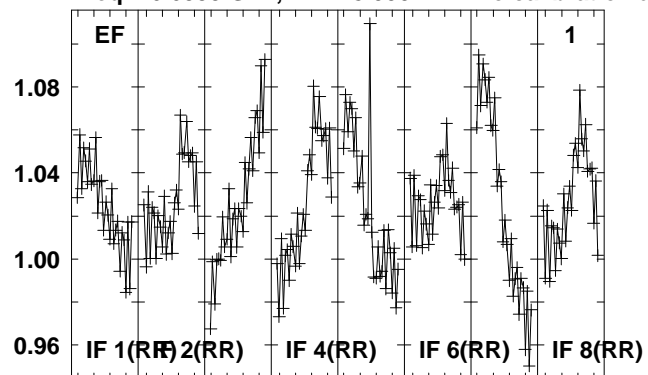

Lower frame: Real Jy
Total-power spectrum Antenna: *
Timerange: 00/11:12:52 to 00/11:14:20

Plot file version 54 created 15-MAR-2012 17:31:02

G85.40 EZ020E 2.UVDATA.1

Freq = 6.6335 GHz, Bw = 8.000 MH No calibration applied and no bandpass applied

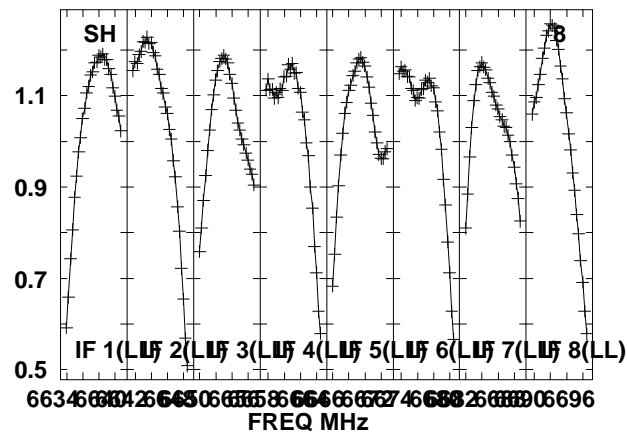
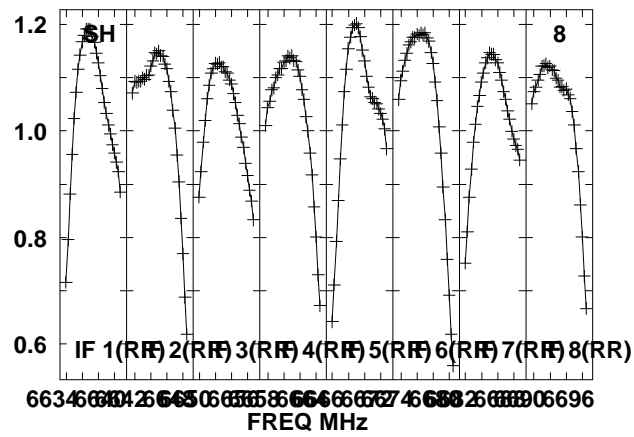
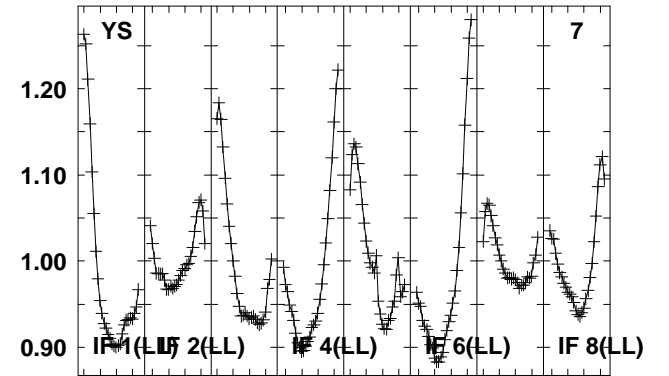
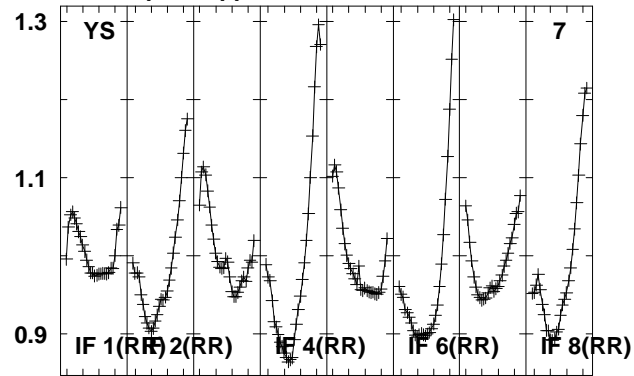
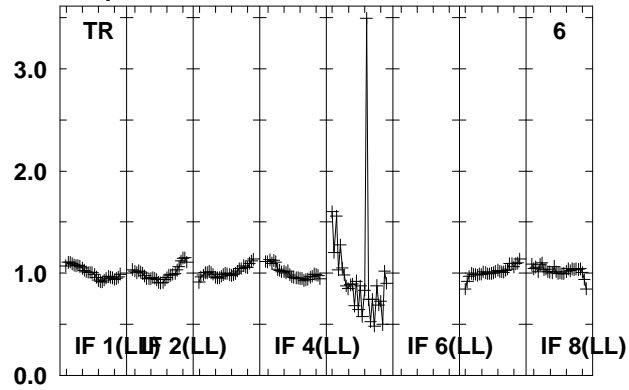

Lower frame: Real Jy
Total-power spectrum Antenna: *
Timerange: 00/11:12:52 to 00/11:14:20

Plot file version 55 created 15-MAR-2012 17:31:03

2102-G85 EZ020E 2.UVDATA.1

Freq = 6.6335 GHz, Bw = 8.000 MH No calibration applied and no bandpass applied

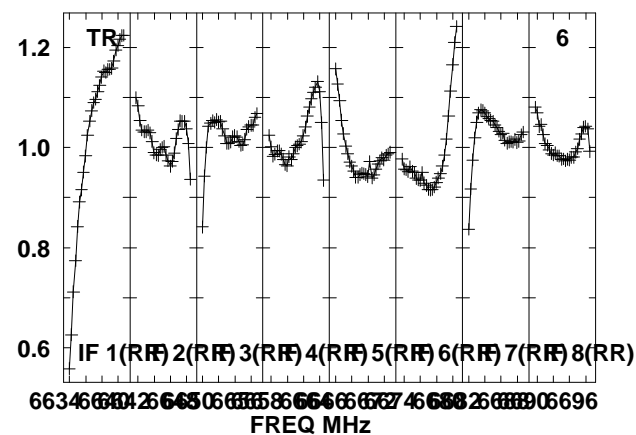
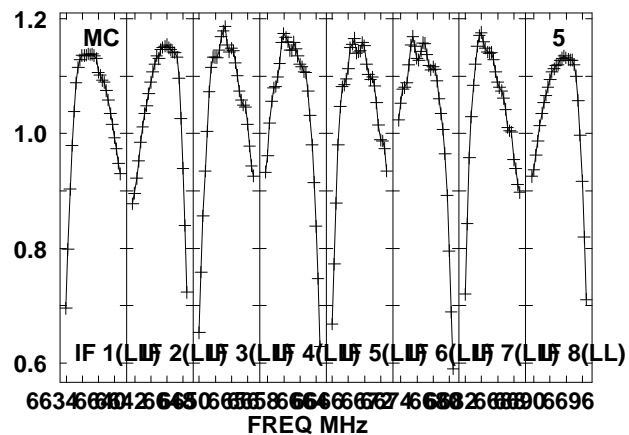
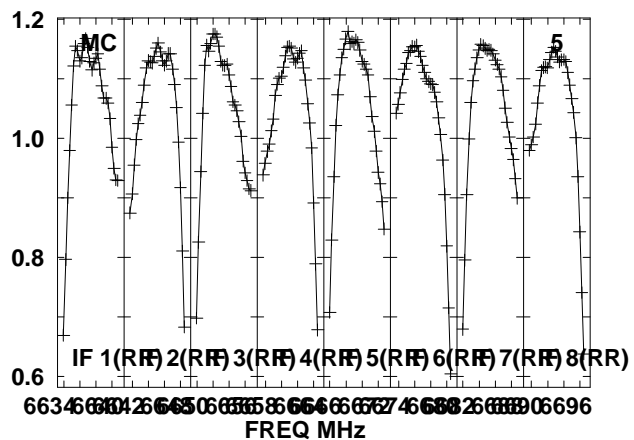
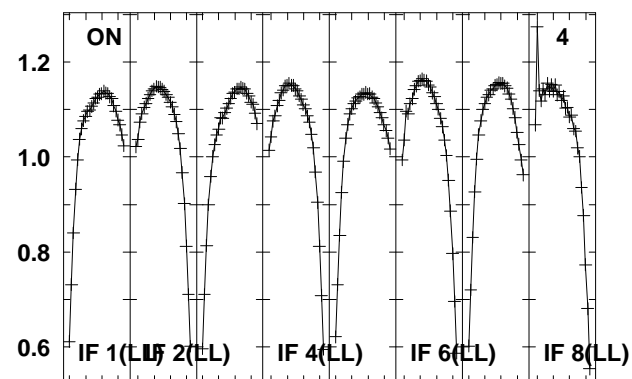
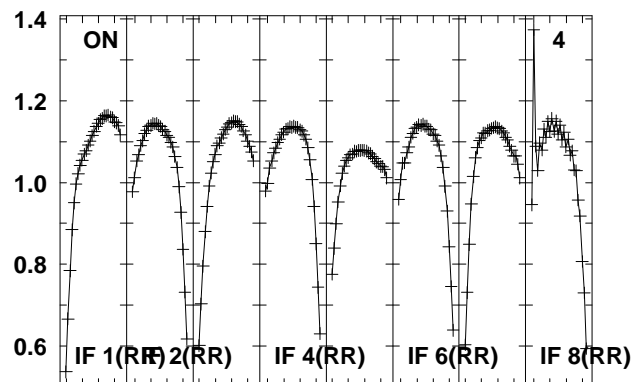
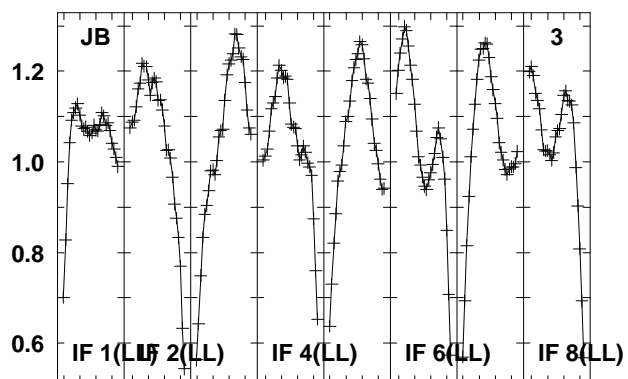
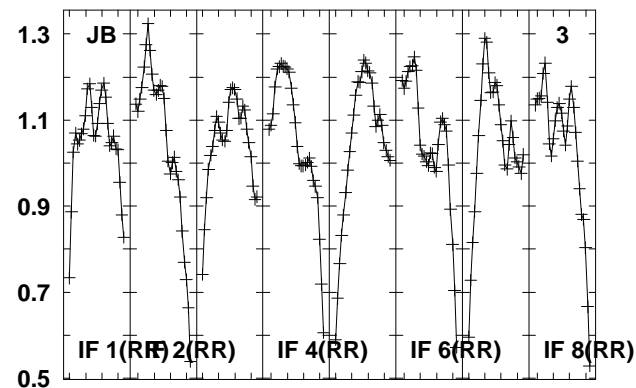
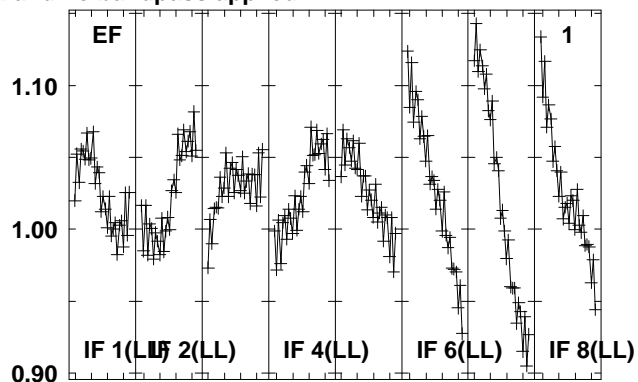
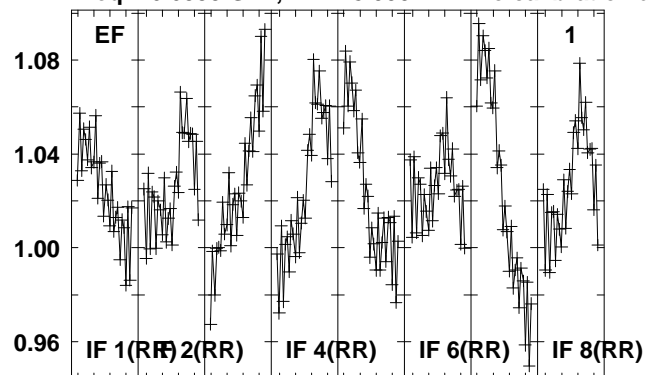

Lower frame: Real Jy
Total-power spectrum Antenna: *
Timerange: 00/11:14:21 to 00/11:15:50

Plot file version 56 created 15-MAR-2012 17:31:03

2102-G85 EZ020E 2.UVDATA.1

Freq = 6.6335 GHz, Bw = 8.000 MH No calibration applied and no bandpass applied

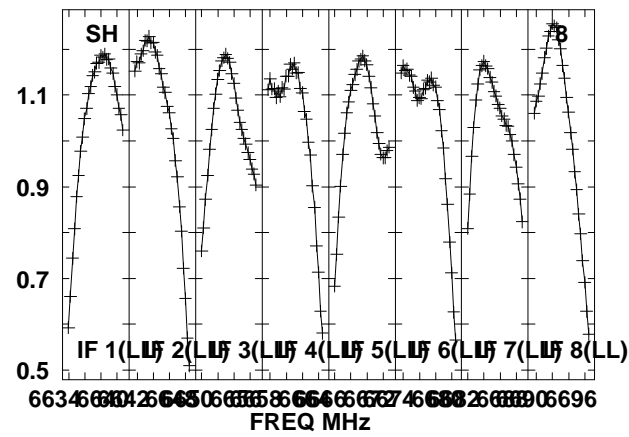
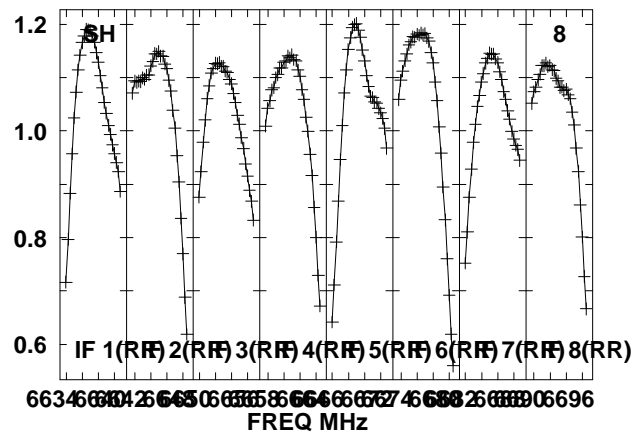
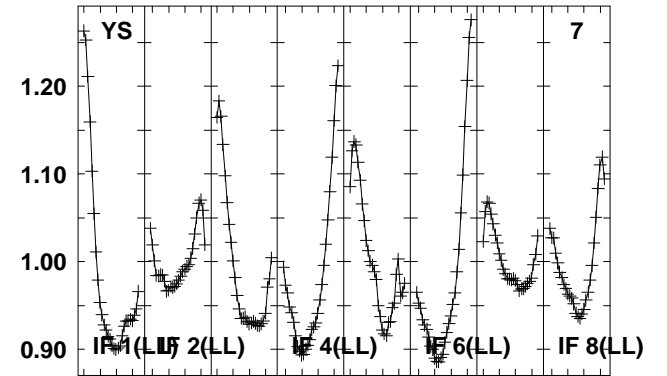
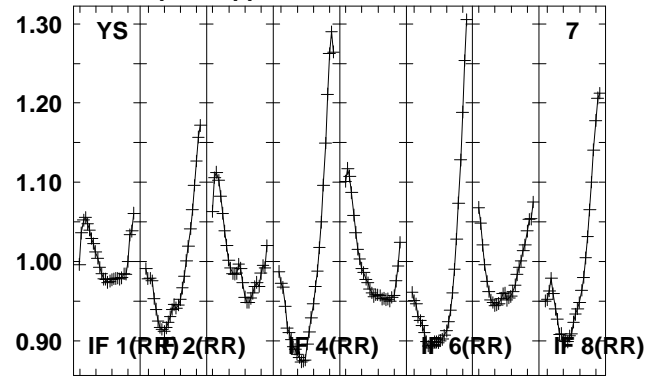
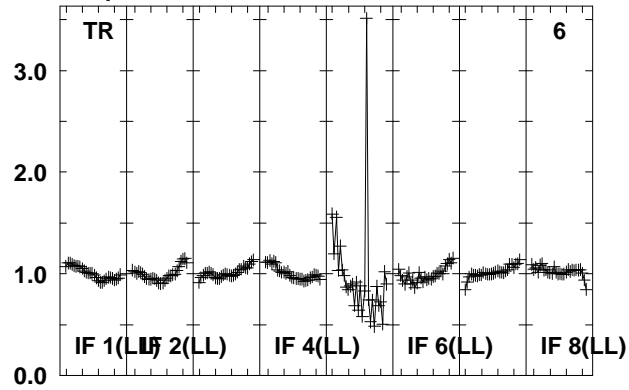

Lower frame: Real Jy
Total-power spectrum Antenna: *
Timerange: 00/11:14:21 to 00/11:15:50

Plot file version 57 created 15-MAR-2012 17:31:04
 G85.40 EZ020E 2.UVDATA.1
 Freq = 6.6335 GHz, Bw = 8.000 MH No calibration applied and no bandpass applied

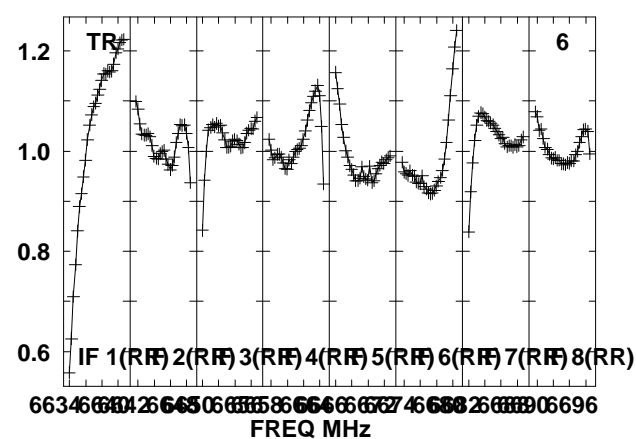
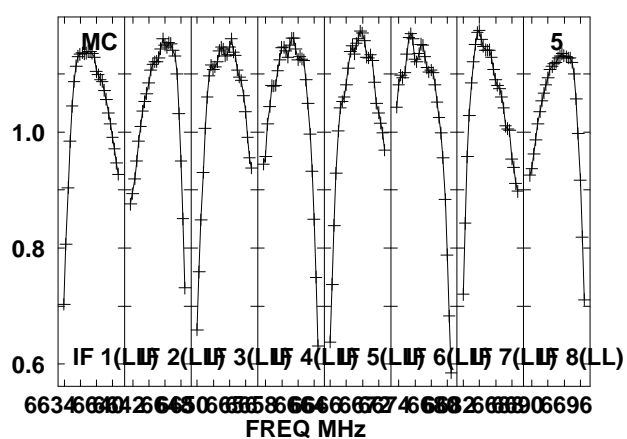
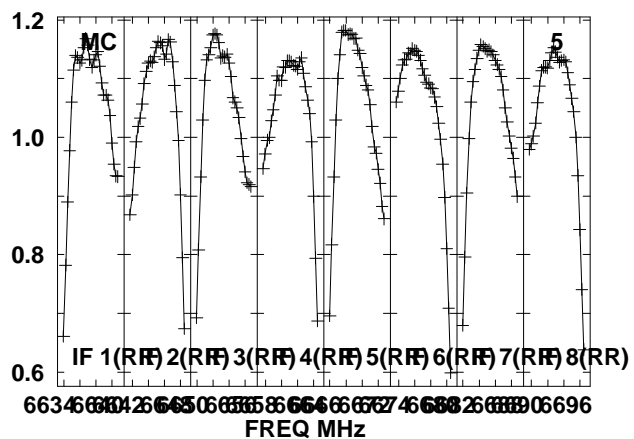
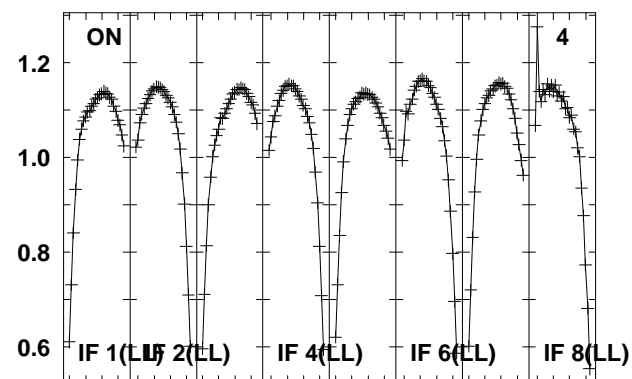
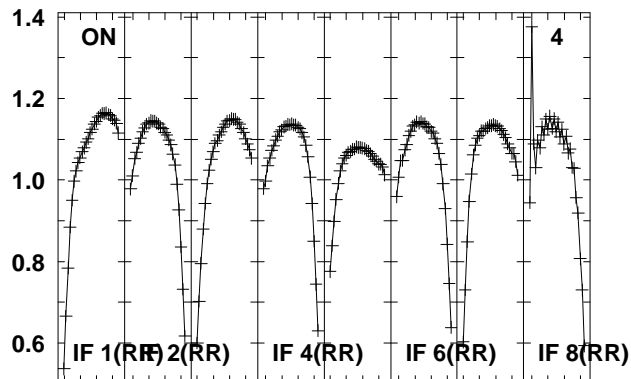
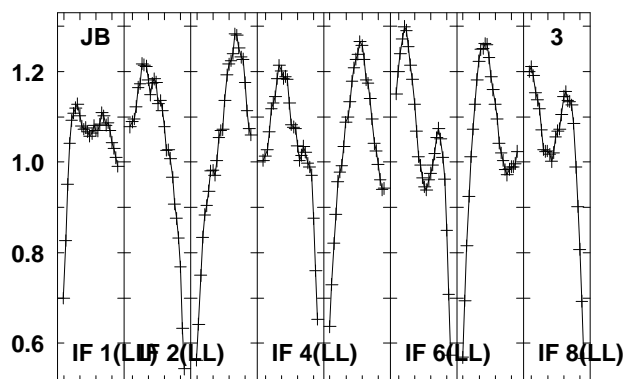
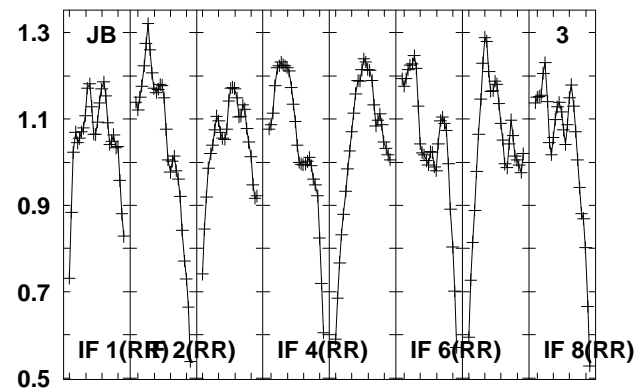
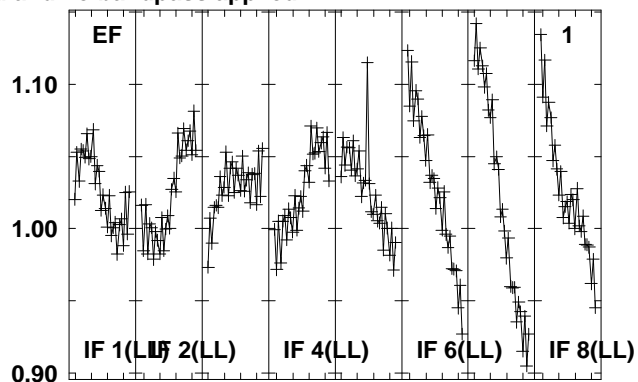
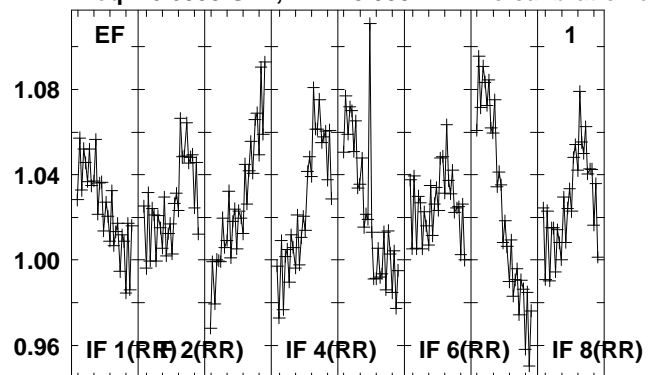

Lower frame: Real Jy
 Total-power spectrum Antenna: *
 Timerange: 00/11:15:51 to 00/11:17:19

Plot file version 58 created 15-MAR-2012 17:31:04

G85.40 EZ020E 2.UVDATA.1

Freq = 6.6335 GHz, Bw = 8.000 MH No calibration applied and no bandpass applied

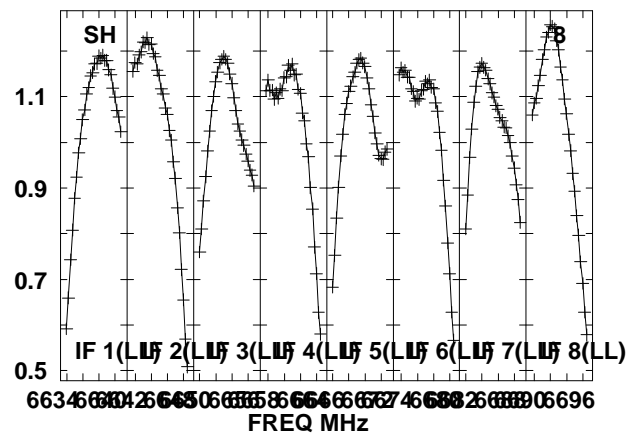
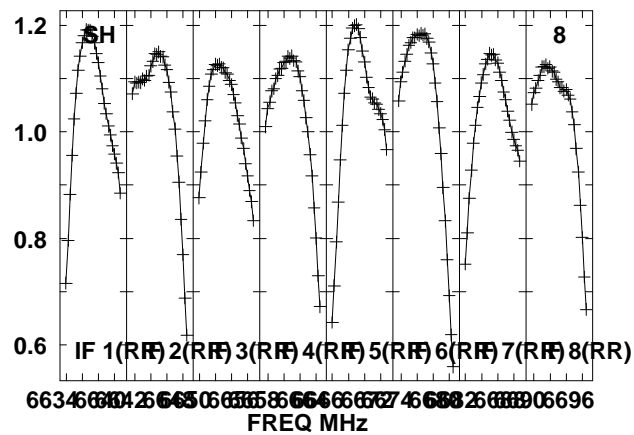
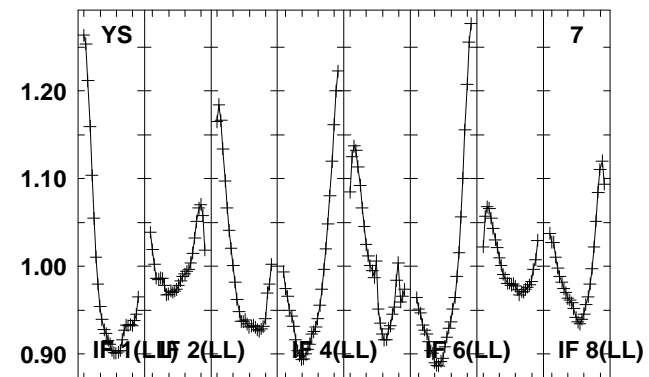
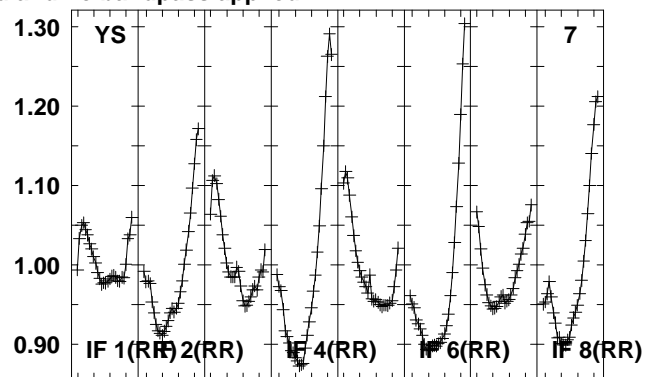
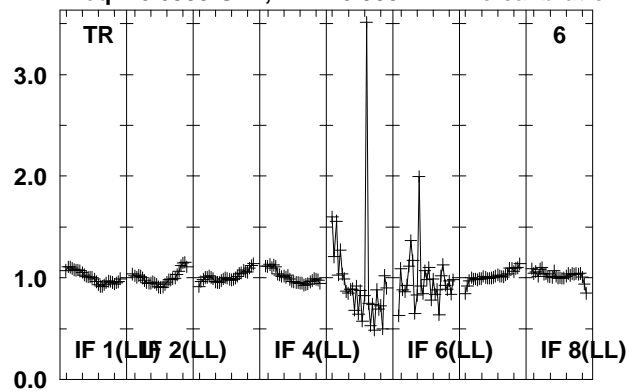

Lower frame: Real Jy
Total-power spectrum Antenna: *
Timerange: 00/11:15:51 to 00/11:17:19

Plot file version 59 created 15-MAR-2012 17:31:05
 2114-G85 EZ020E 2.UVDATA.1
 Freq = 6.6335 GHz, Bw = 8.000 MH No calibration applied and no bandpass applied

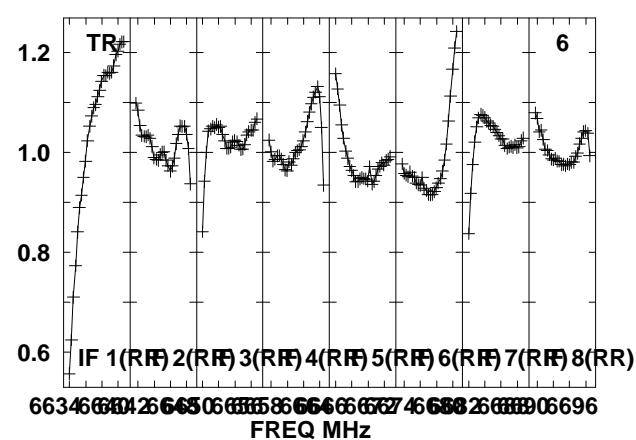
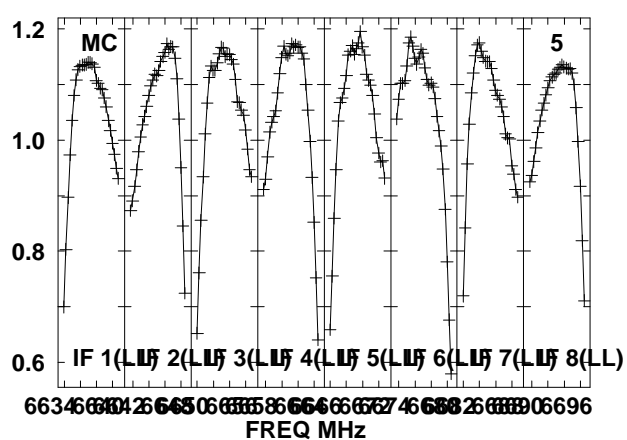
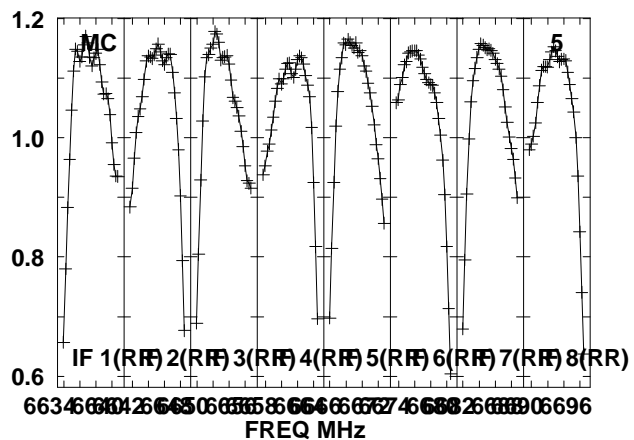
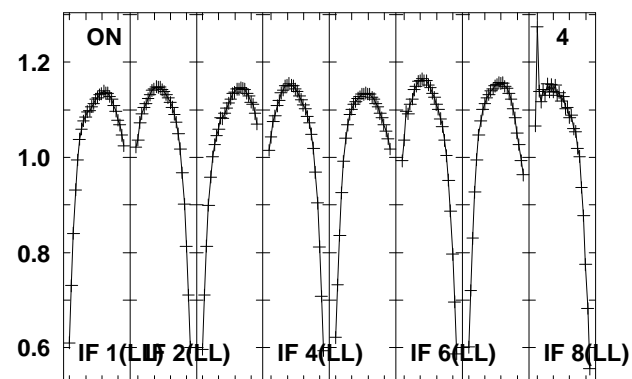
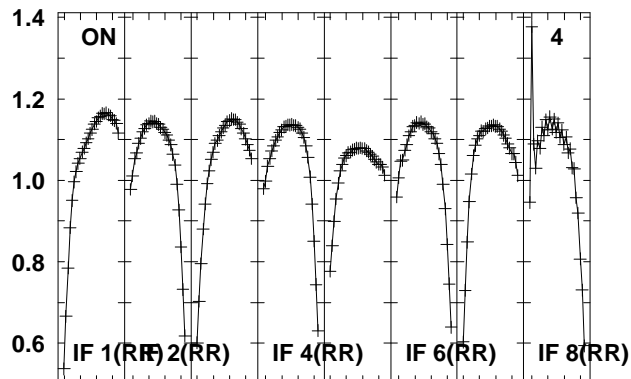
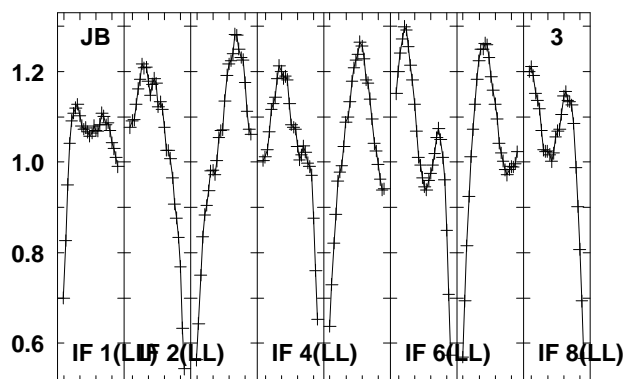
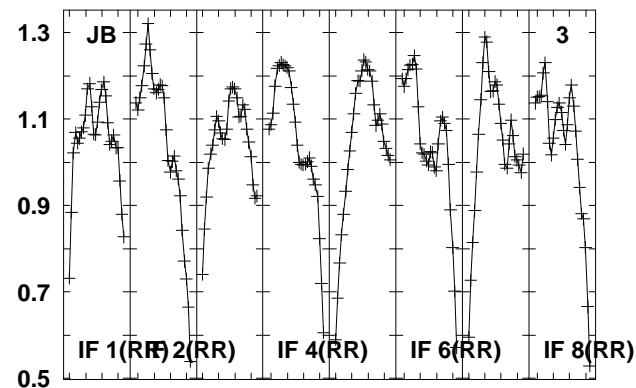
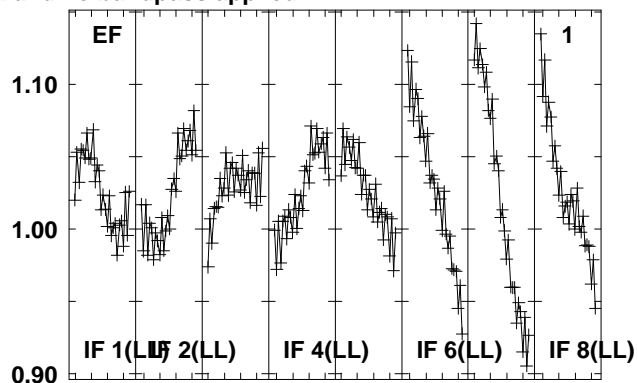
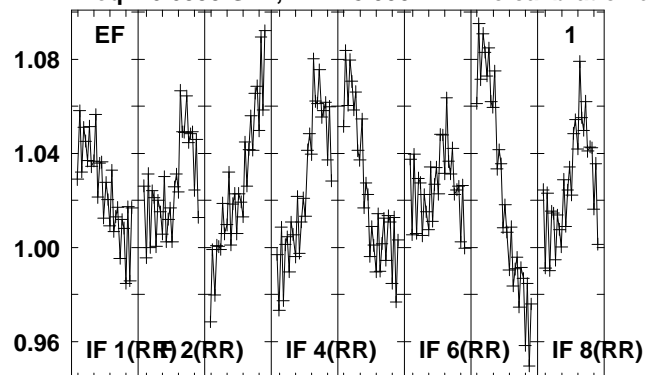

Lower frame: Real Jy
 Total-power spectrum Antenna: *
 Timerange: 00/11:17:21 to 00/11:18:50

Plot file version 60 created 15-MAR-2012 17:31:06

2114-G85 EZ020E 2.UVDATA.1

Freq = 6.6335 GHz, Bw = 8.000 MH No calibration applied and no bandpass applied

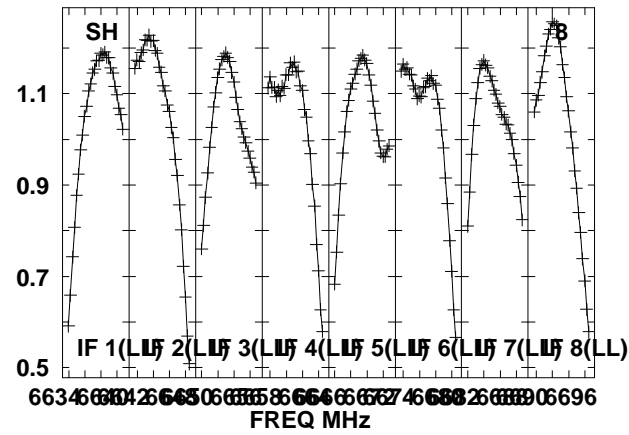
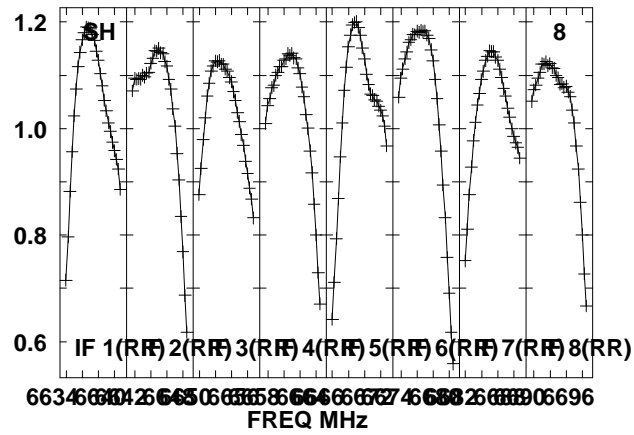
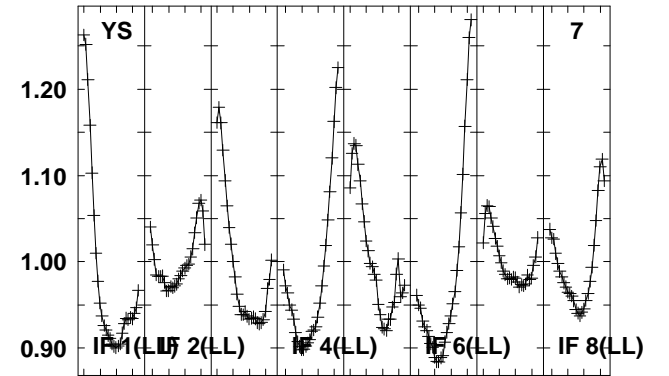
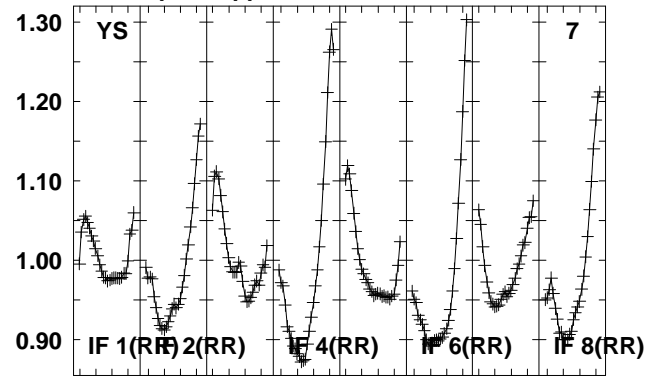
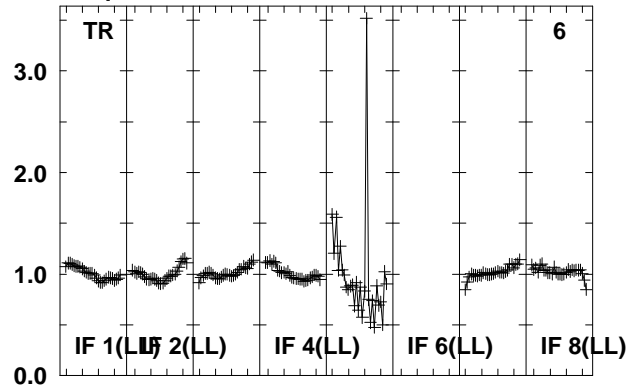

Lower frame: Real Jy
Total-power spectrum Antenna: *
Timerange: 00/11:17:21 to 00/11:18:50

Plot file version 62 created 15-MAR-2012 17:31:07

G85.40 EZ020E 2.UVDATA.1

Freq = 6.6335 GHz, Bw = 8.000 MH No calibration applied and no bandpass applied

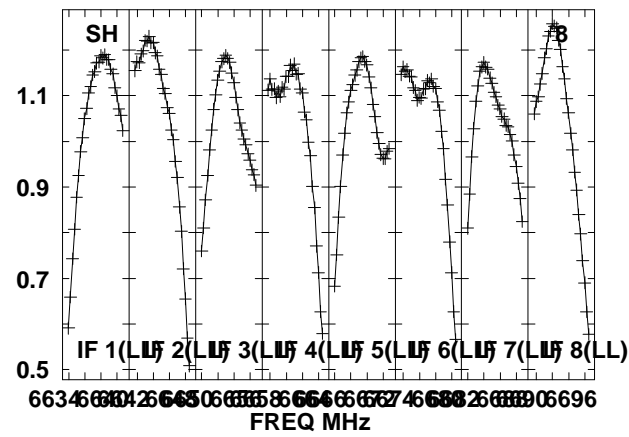
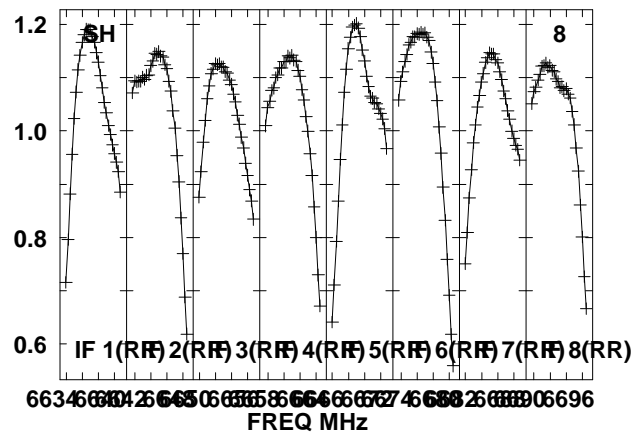
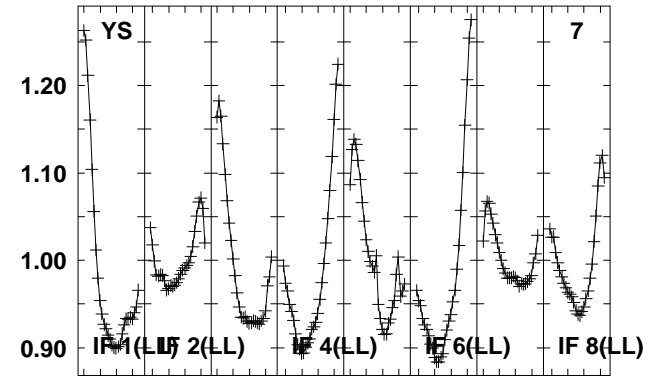
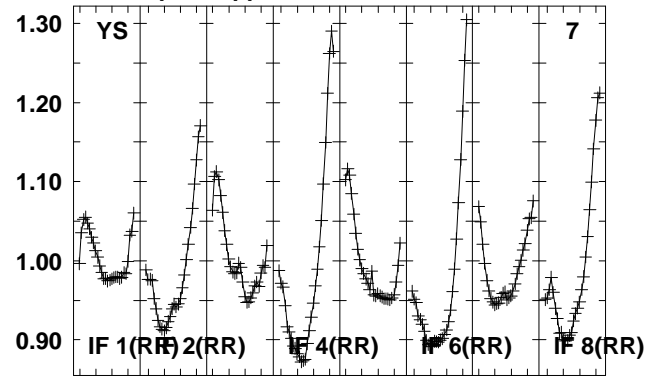
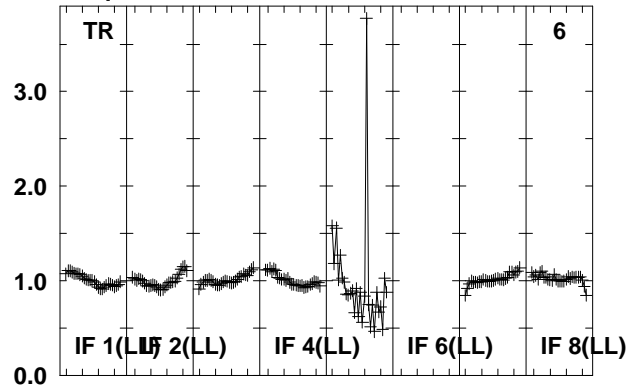

Lower frame: Real Jy
Total-power spectrum Antenna: *
Timerange: 00/11:18:52 to 00/11:20:20

Plot file version 63 created 15-MAR-2012 17:31:07

2102-G85 EZ020E 2.UVDATA.1

Freq = 6.6335 GHz, Bw = 8.000 MH No calibration applied and no bandpass applied

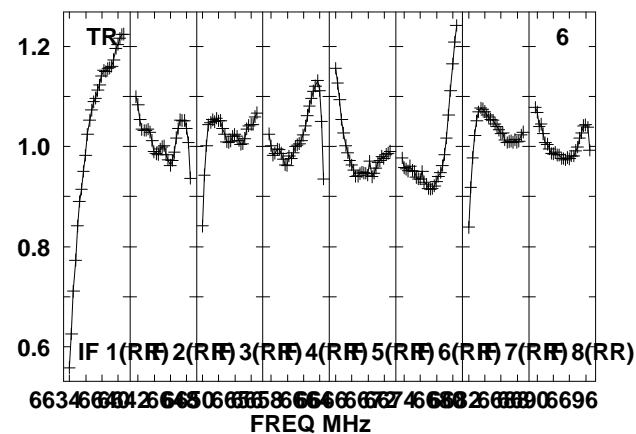
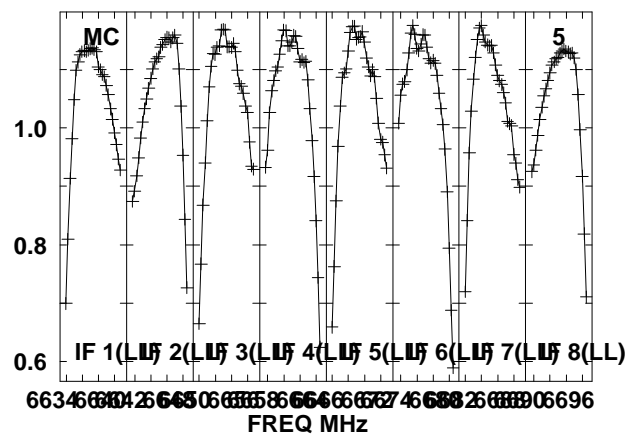
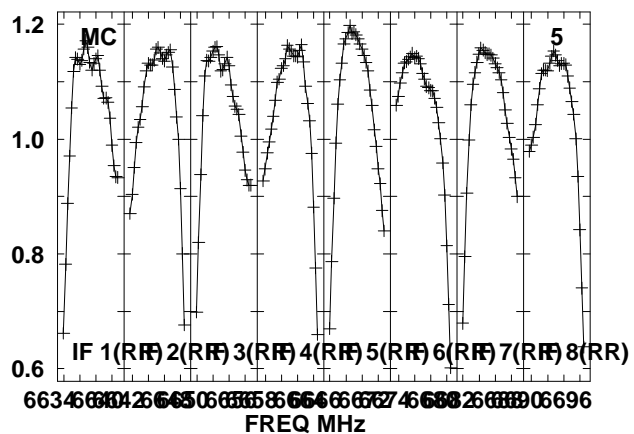
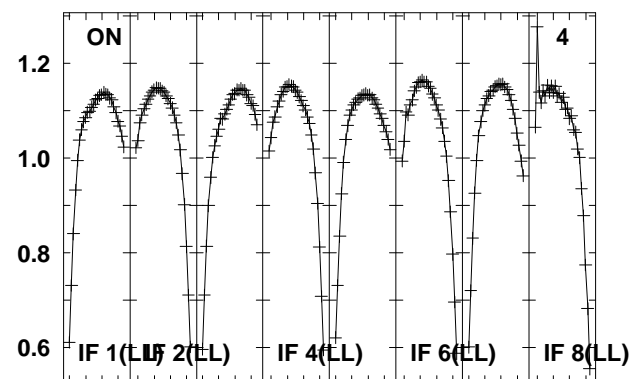
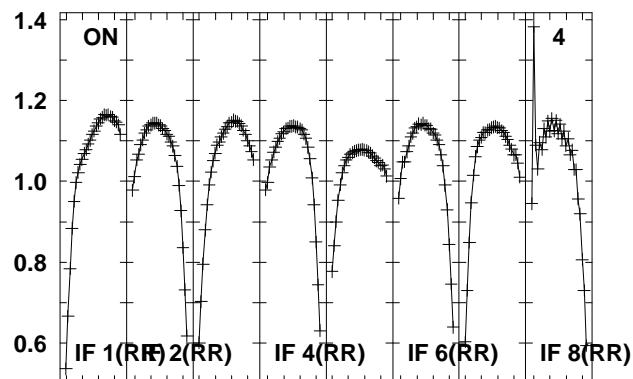
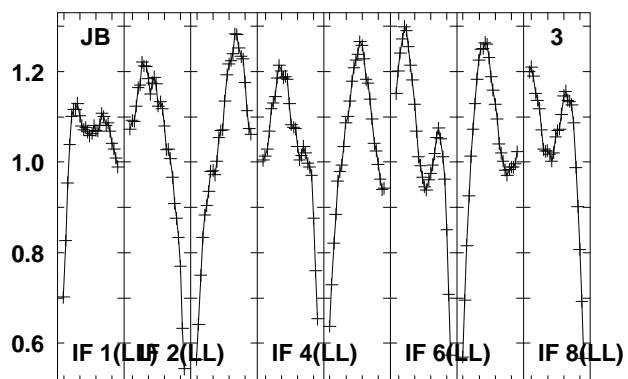
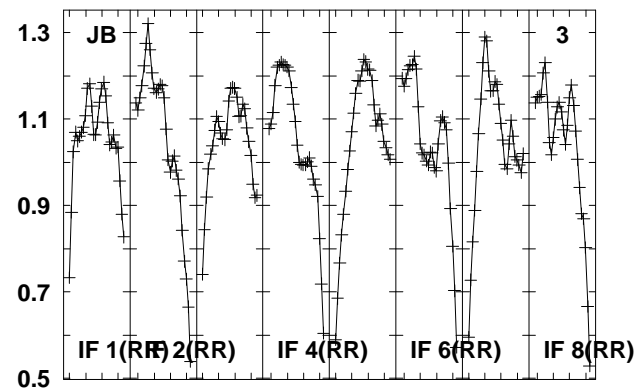
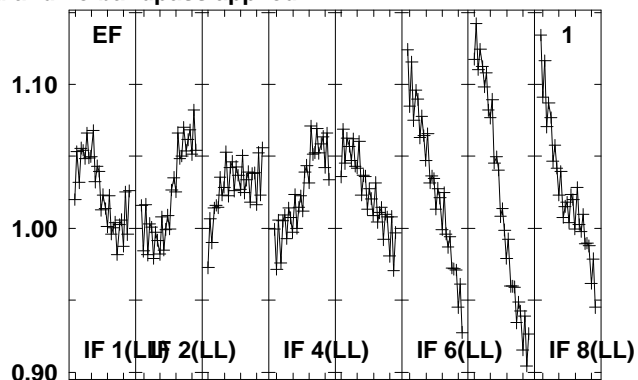
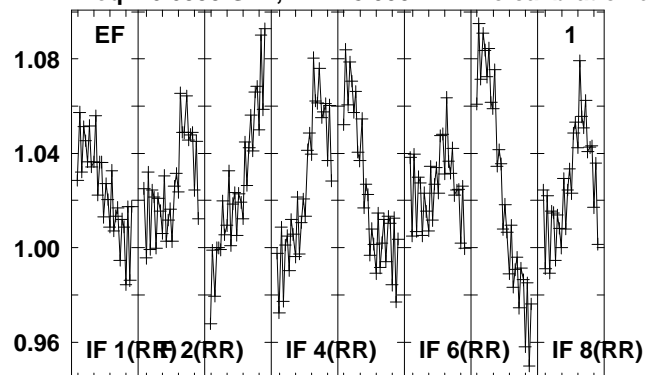

Lower frame: Real Jy
Total-power spectrum Antenna: *
Timerange: 00/11:20:21 to 00/11:21:49

Plot file version 64 created 15-MAR-2012 17:31:08

2102-G85 EZ20E 2.UVDATA.1

Freq = 6.6335 GHz, Bw = 8.000 MH No calibration applied and no bandpass applied

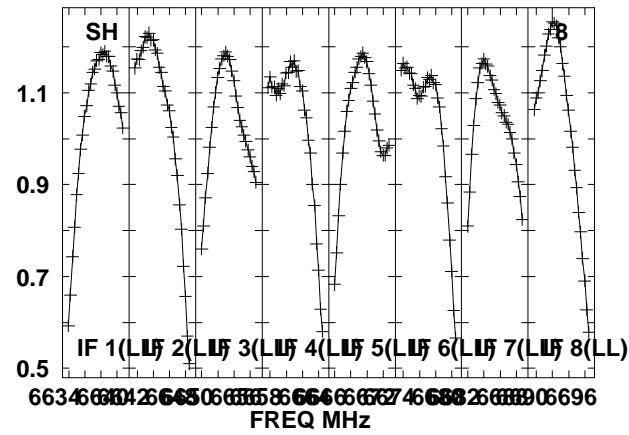
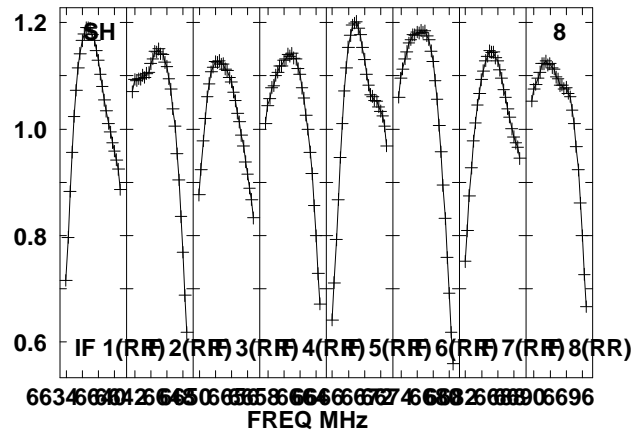
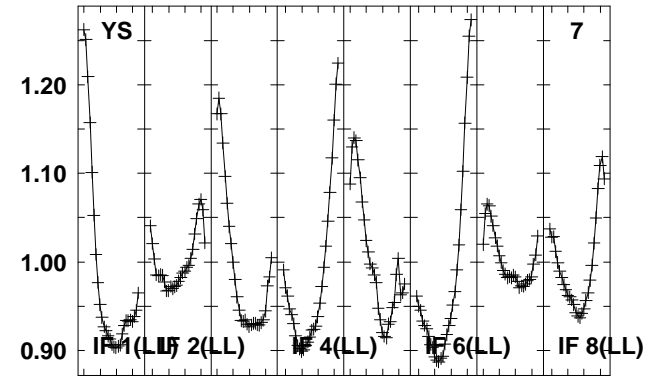
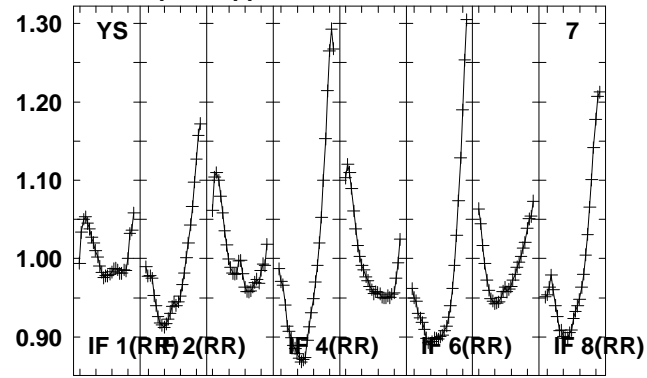
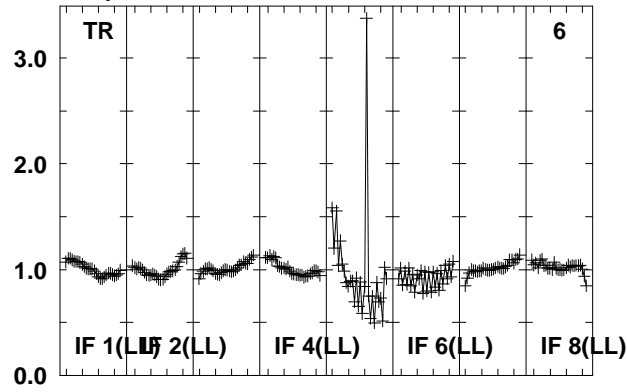

Lower frame: Real Jy
Total-power spectrum Antenna: *
Timerange: 00/11:20:21 to 00/11:21:49

Plot file version 65 created 15-MAR-2012 17:31:09

G85.40 EZ20E 2.UVDATA.1

Freq = 6.6335 GHz, Bw = 8.000 MH No calibration applied and no bandpass applied

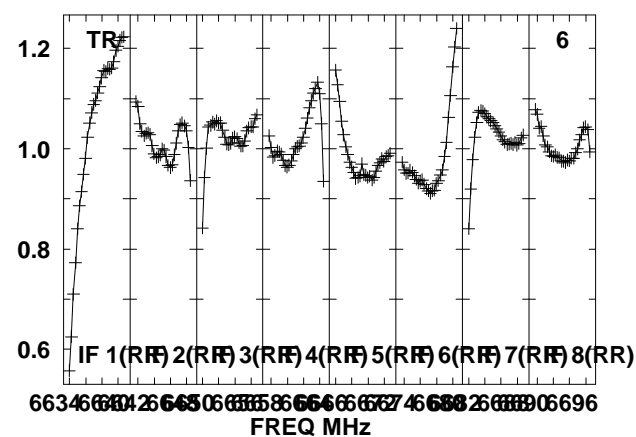
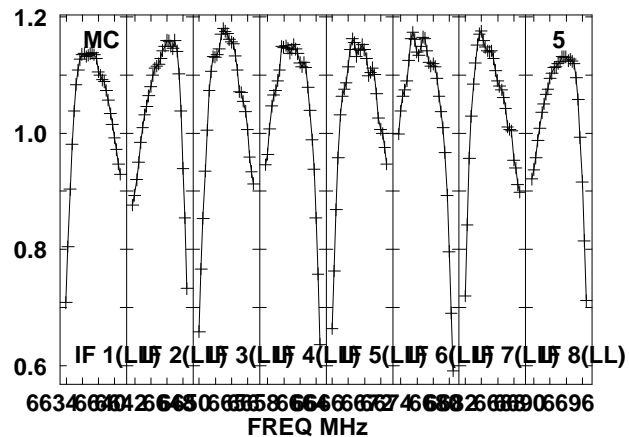
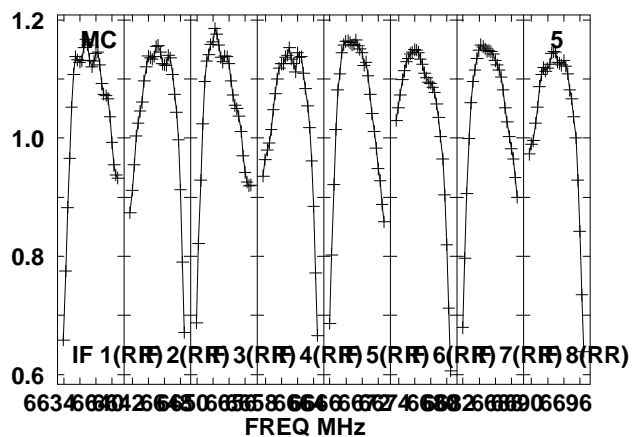
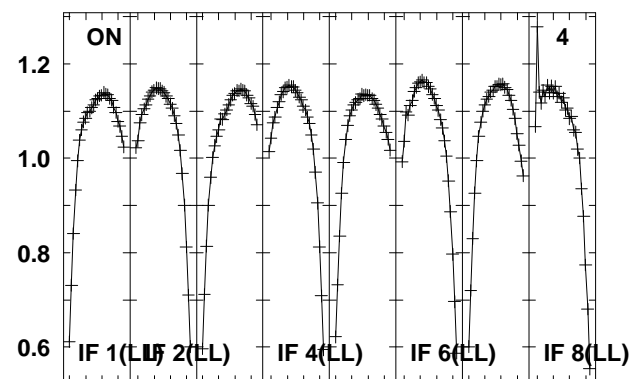
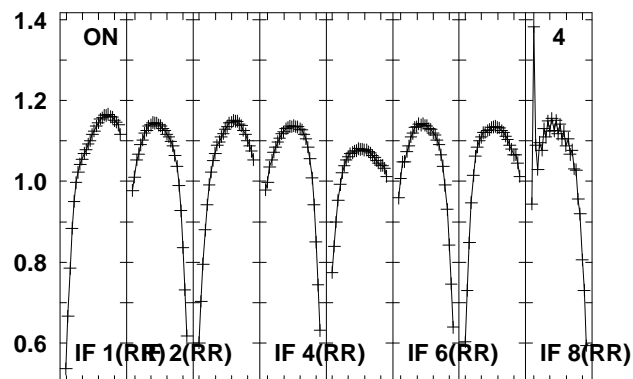
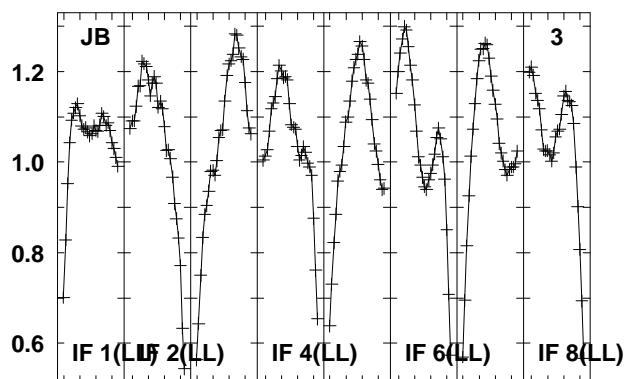
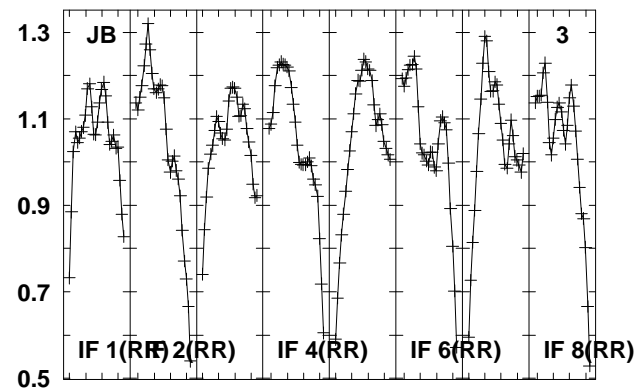
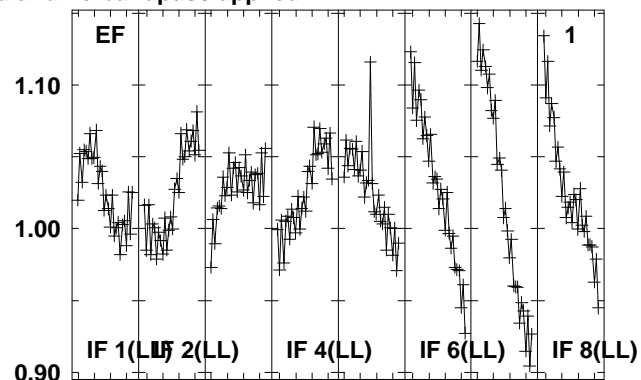
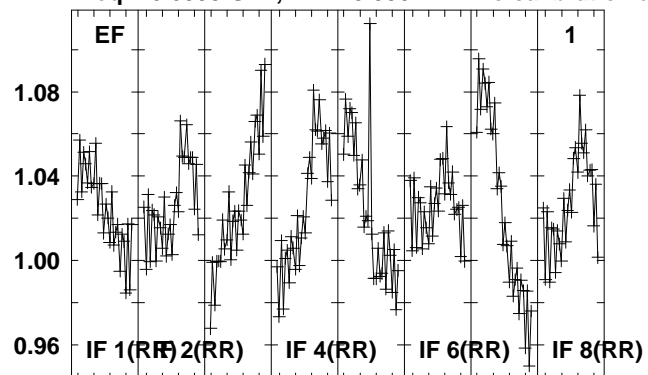

Lower frame: Real Jy
Total-power spectrum Antenna: *
Timerange: 00/11:22:25 to 00/11:23:23

Plot file version 66 created 15-MAR-2012 17:31:09

G85.40 EZ020E 2.UVDATA.1

Freq = 6.6335 GHz, Bw = 8.000 MH No calibration applied and no bandpass applied

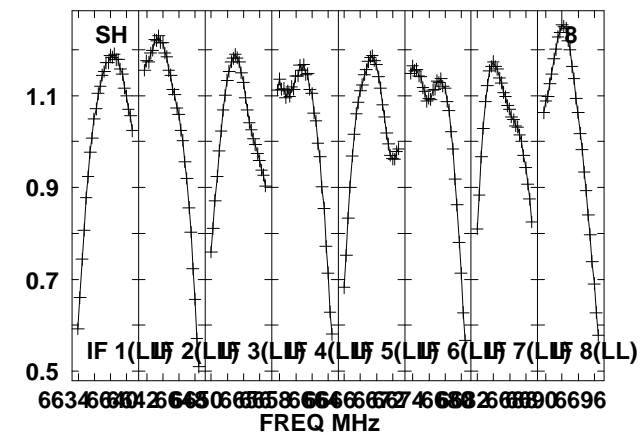
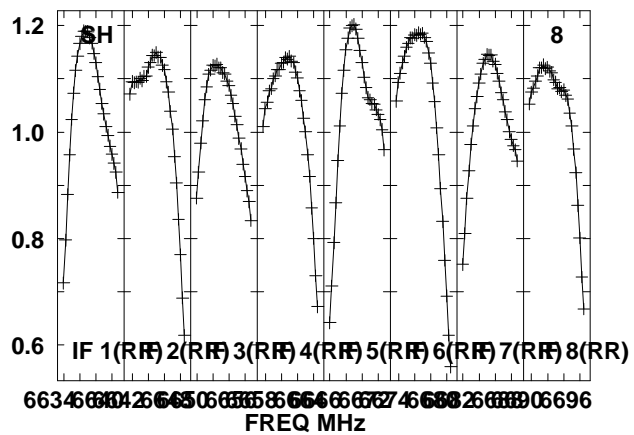
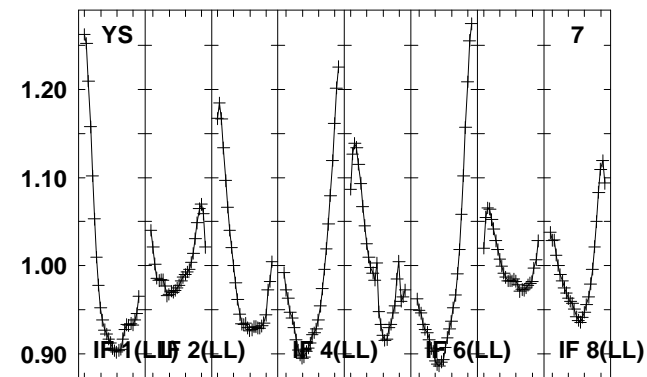
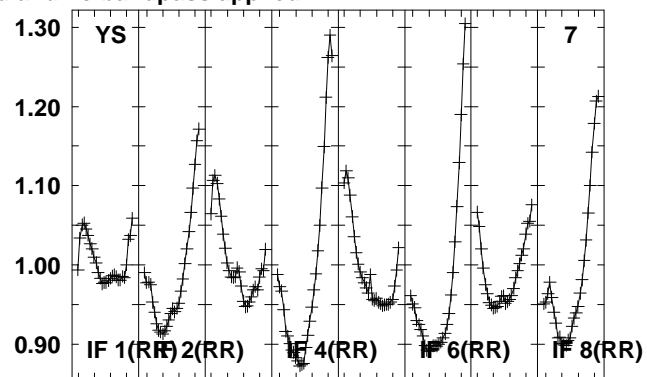
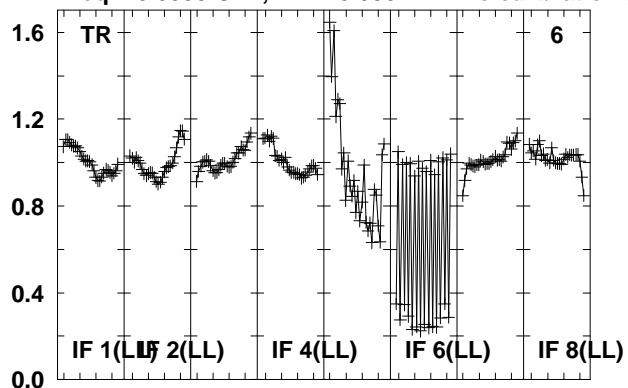

Lower frame: Real Jy
Total-power spectrum Antenna: *
Timerange: 00/11:22:25 to 00/11:23:23

Plot file version 67 created 15-MAR-2012 17:31:10
 2114-G85 EZ020E 2.UVDATA.1
 Freq = 6.6335 GHz, Bw = 8.000 MH No calibration applied and no bandpass applied

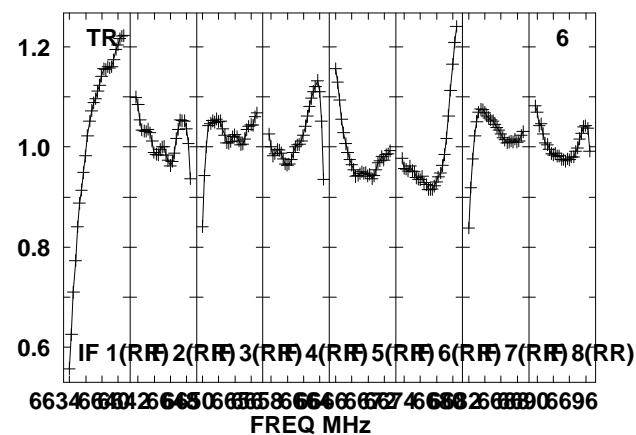
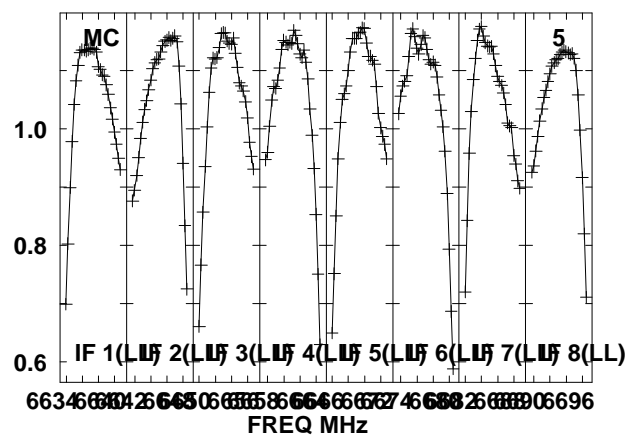
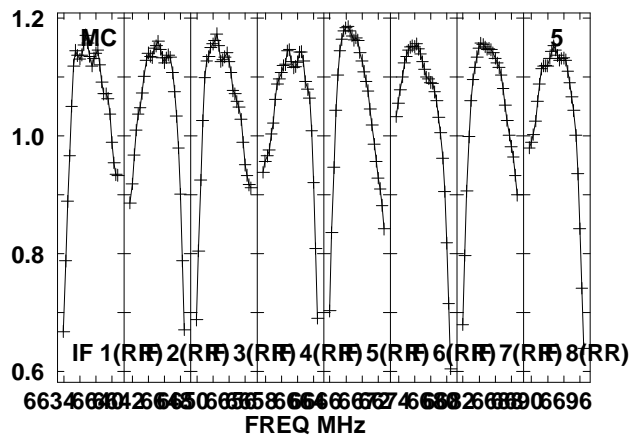
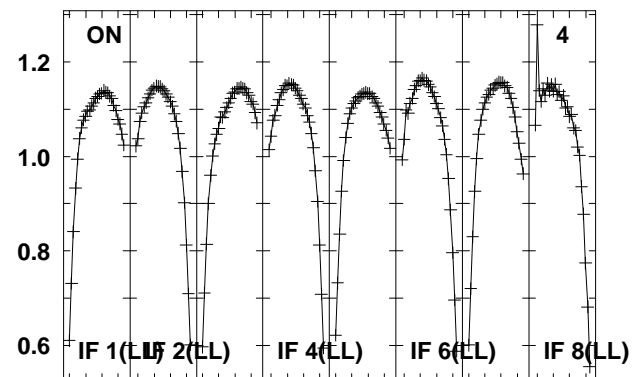
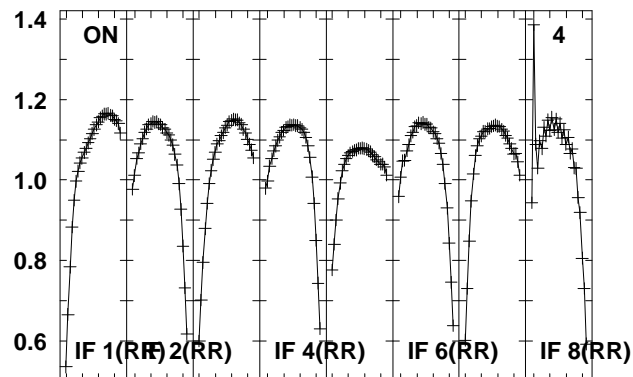
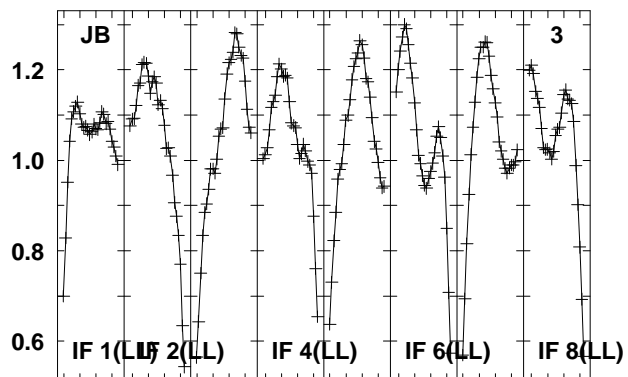
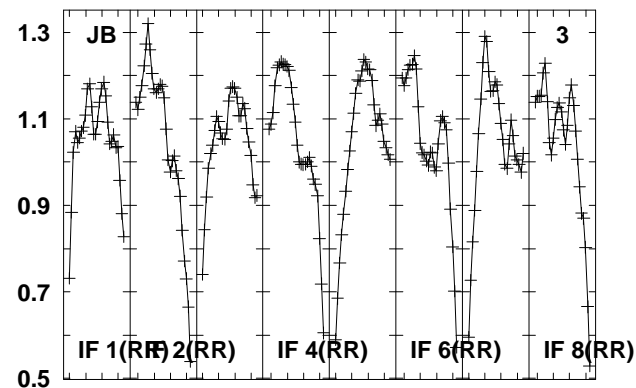
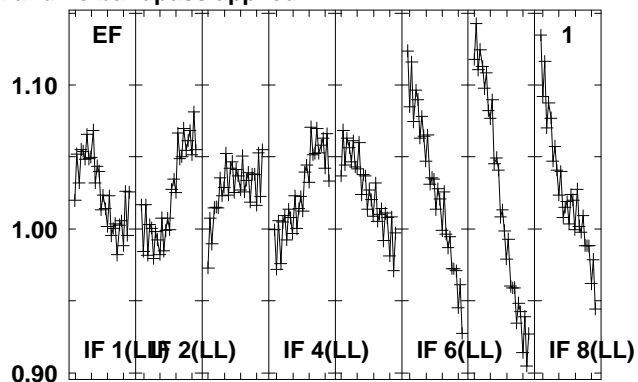
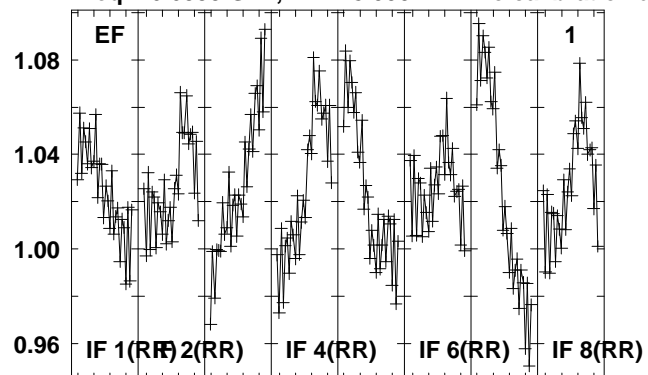

Lower frame: Real Jy
 Total-power spectrum Antenna: *
 Timerange: 00/11:23:24 to 00/11:24:52

Plot file version 68 created 15-MAR-2012 17:31:11

2114-G85 EZ020E 2.UVDATA.1

Freq = 6.6335 GHz, Bw = 8.000 MH No calibration applied and no bandpass applied

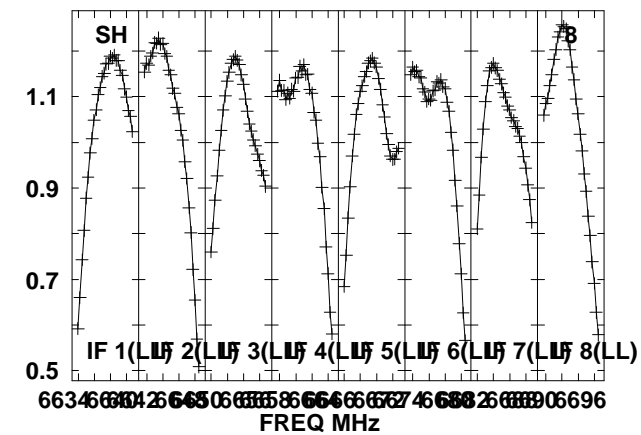
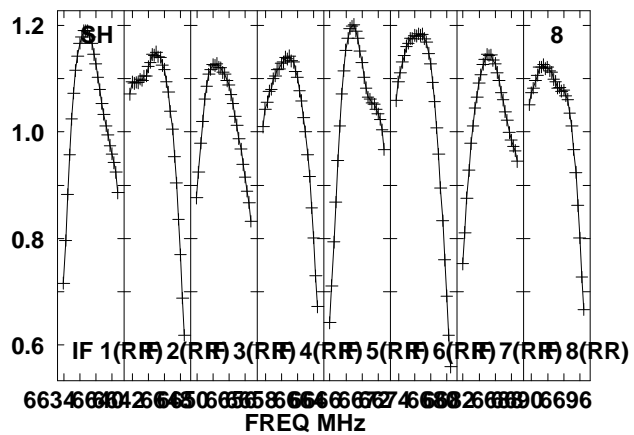
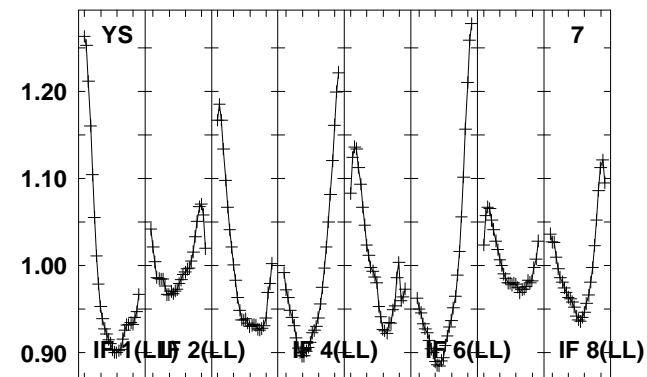
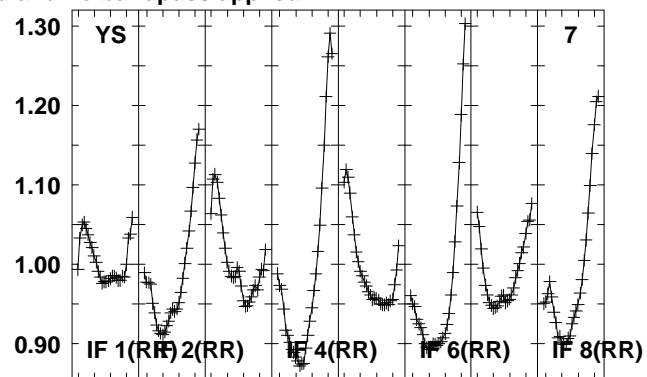
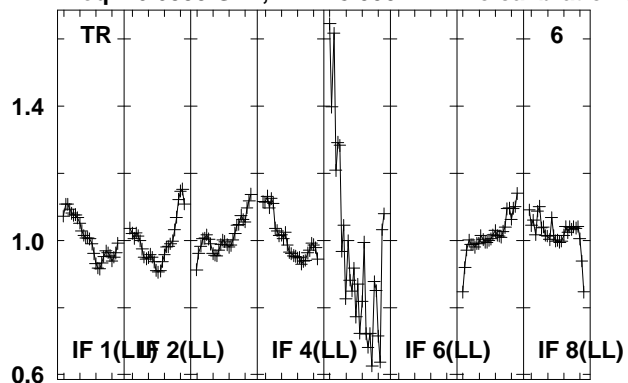

Lower frame: Real Jy
Total-power spectrum Antenna: *
Timerange: 00/11:23:24 to 00/11:24:52

Plot file version 69 created 15-MAR-2012 17:31:11

G85.40 EZ020E 2.UVDATA.1

Freq = 6.6335 GHz, Bw = 8.000 MH No calibration applied and no bandpass applied

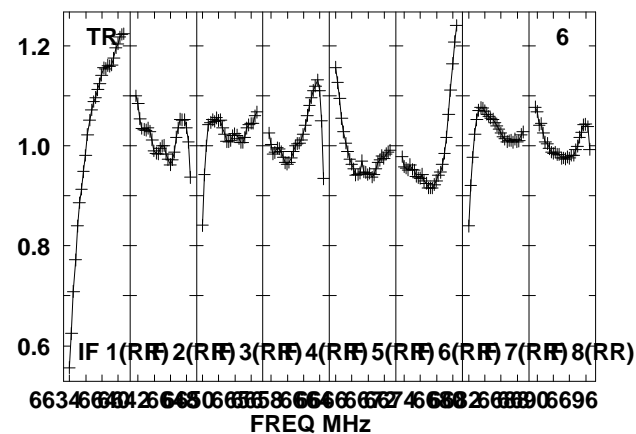
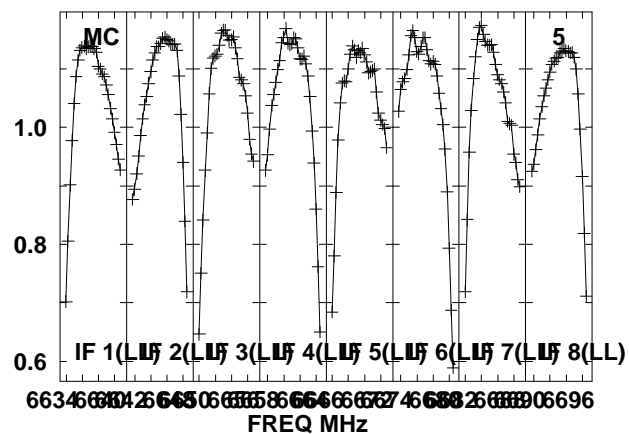
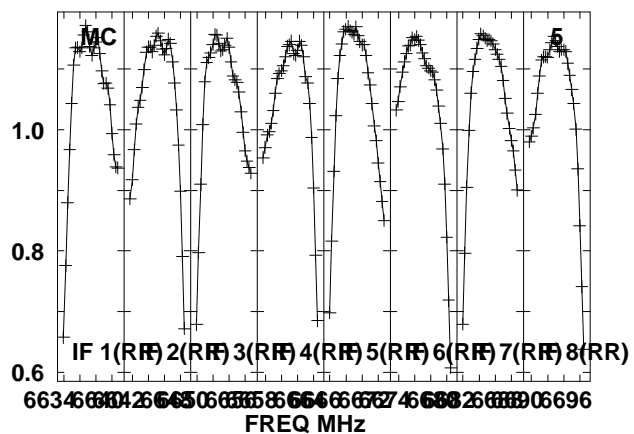
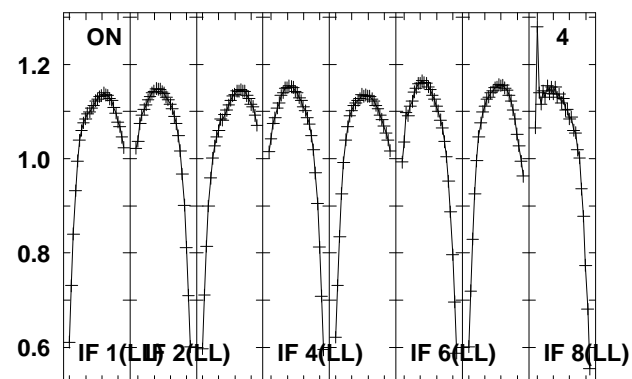
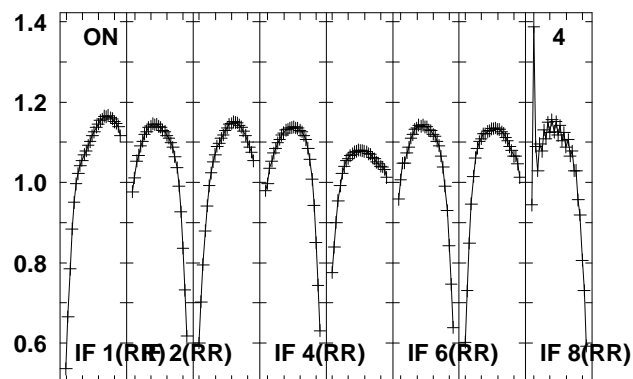
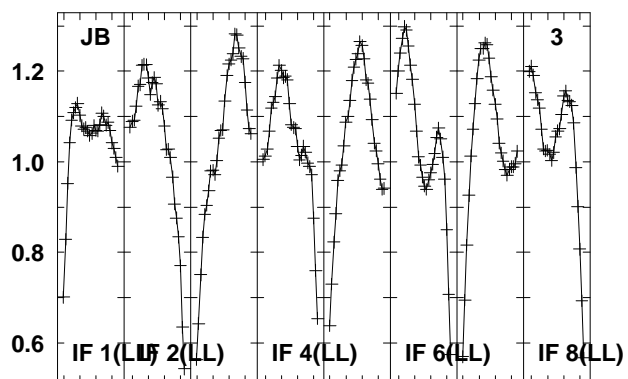
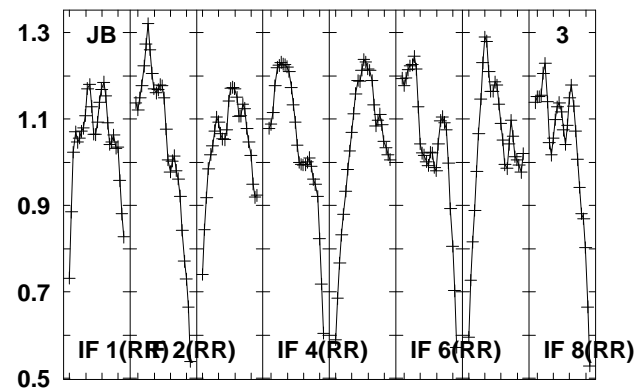
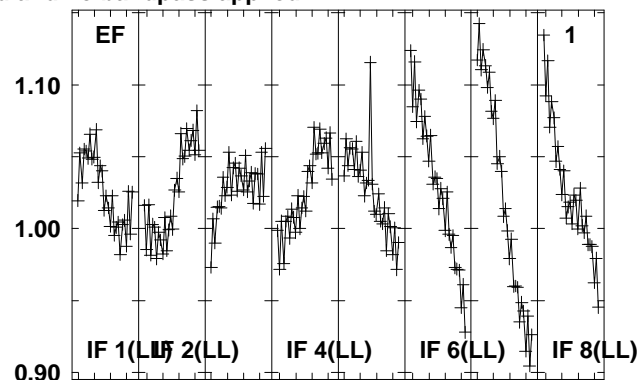
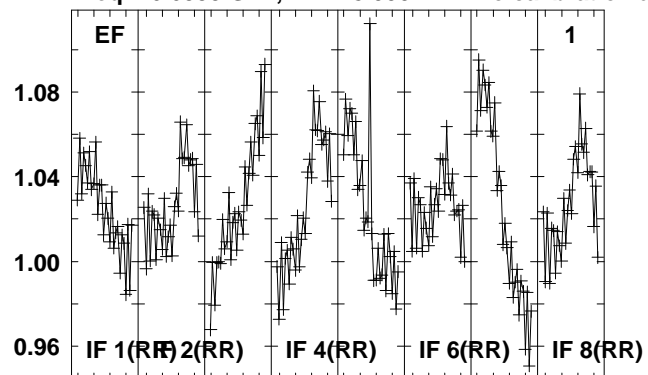

Lower frame: Real Jy
Total-power spectrum Antenna: *
Timerange: 00/11:24:55 to 00/11:26:23

Plot file version 70 created 15-MAR-2012 17:31:12

G85.40 EZ020E 2.UVDATA.1

Freq = 6.6335 GHz, Bw = 8.000 MH No calibration applied and no bandpass applied

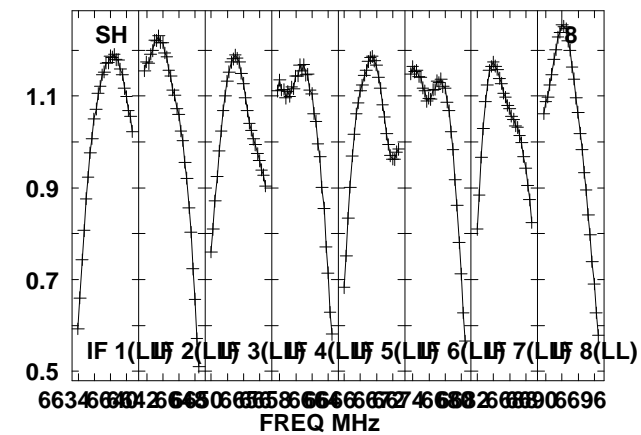
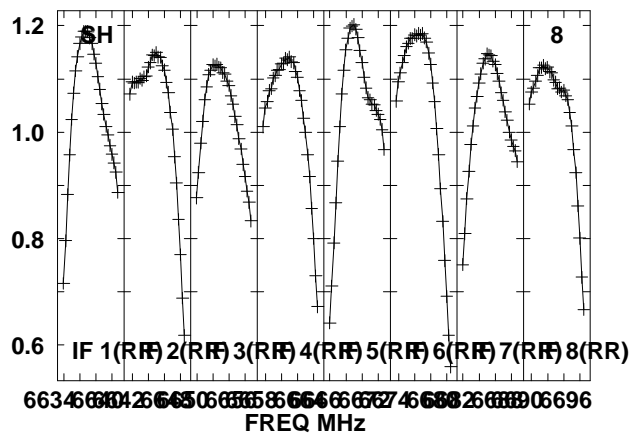
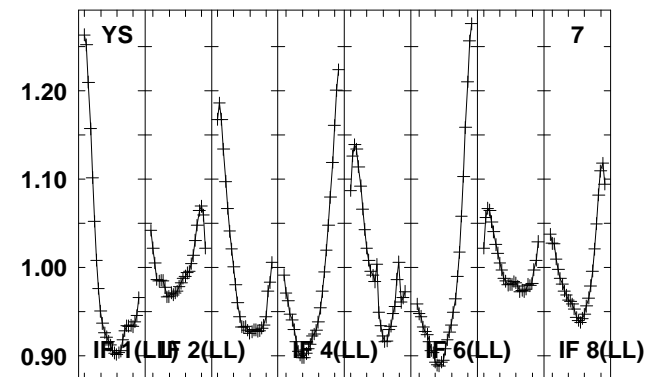
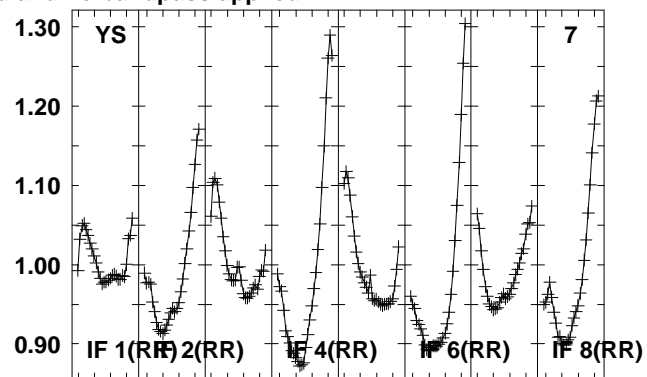
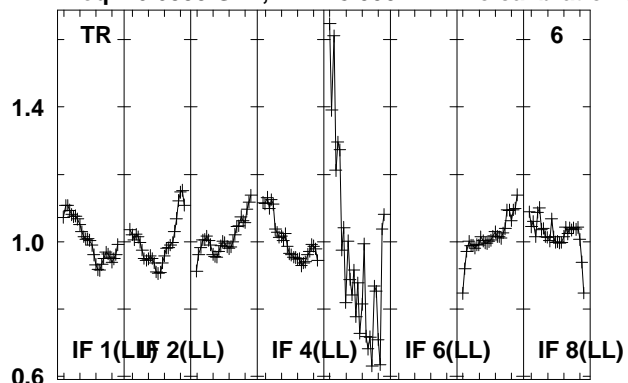

Lower frame: Real Jy
Total-power spectrum Antenna: *
Timerange: 00/11:24:55 to 00/11:26:23

Plot file version 71 created 15-MAR-2012 17:31:12
 2102-G85 EZ020E 2.UVDATA.1
 Freq = 6.6335 GHz, Bw = 8.000 MH No calibration applied and no bandpass applied

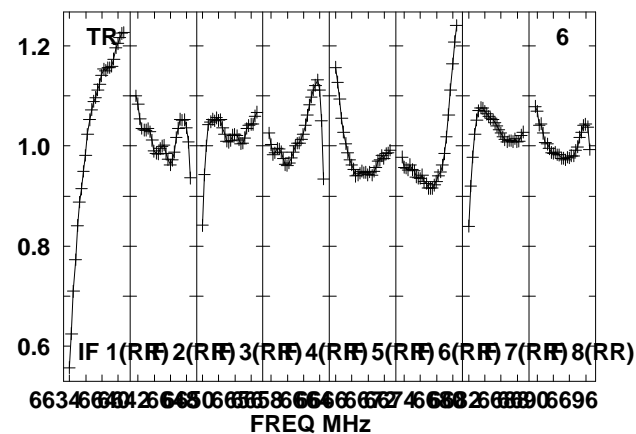
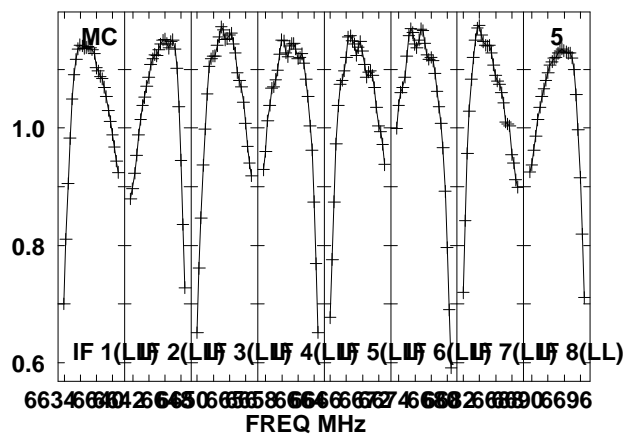
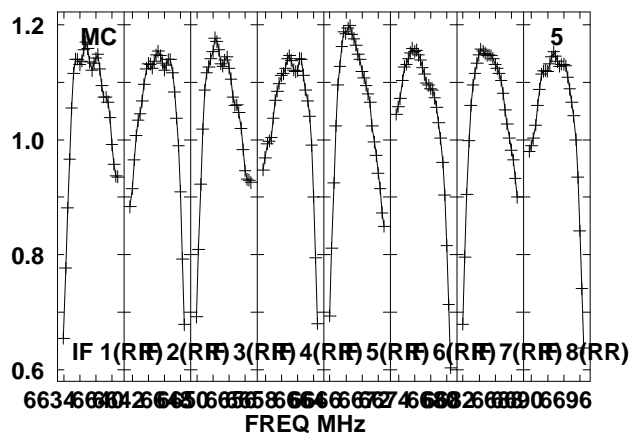
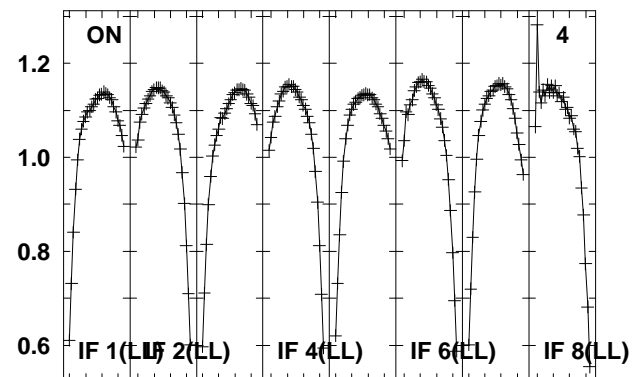
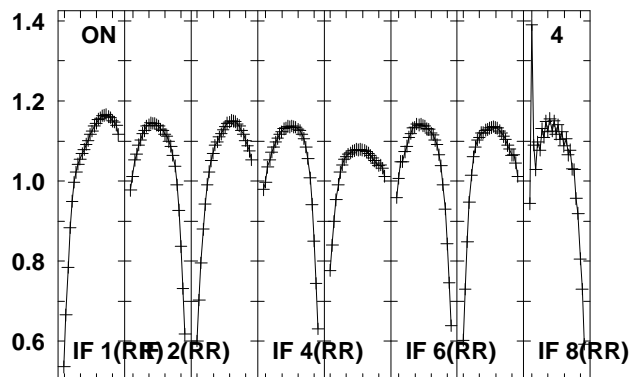
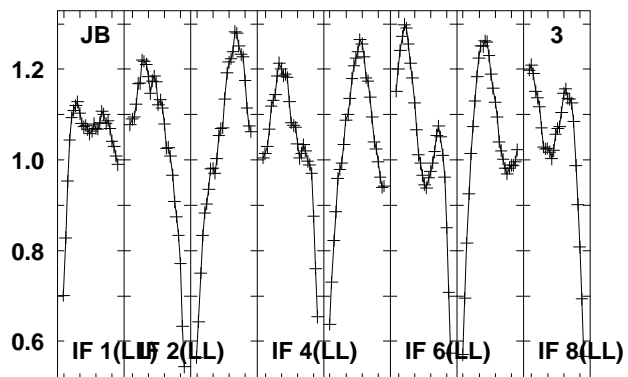
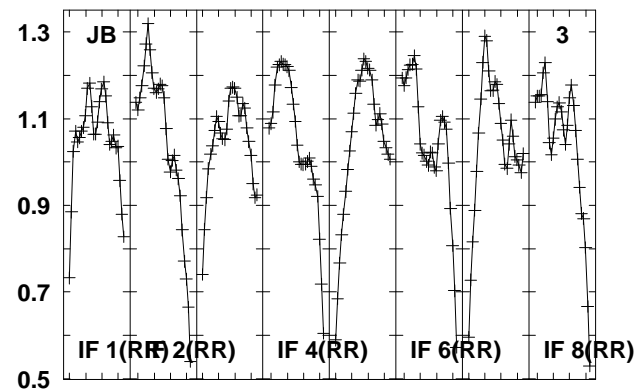
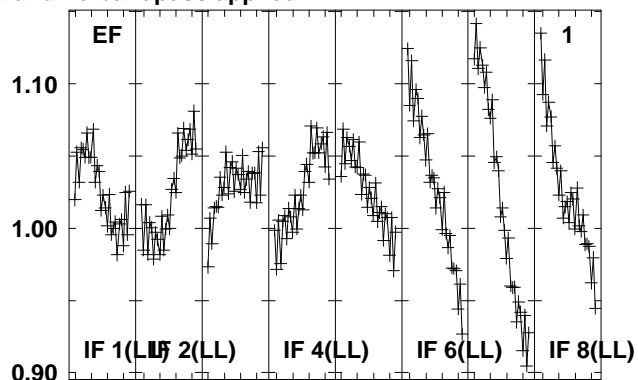
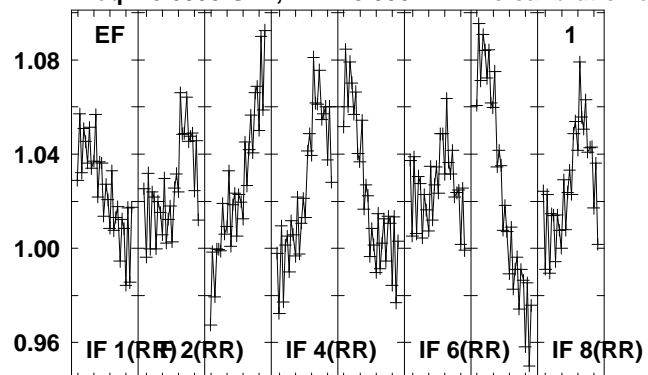

Lower frame: Real Jy
 Total-power spectrum Antenna: *
 Timerange: 00/11:26:24 to 00/11:27:52

Plot file version 72 created 15-MAR-2012 17:31:13

2102-G85 EZ020E 2.UVDATA.1

Freq = 6.6335 GHz, Bw = 8.000 MH No calibration applied and no bandpass applied

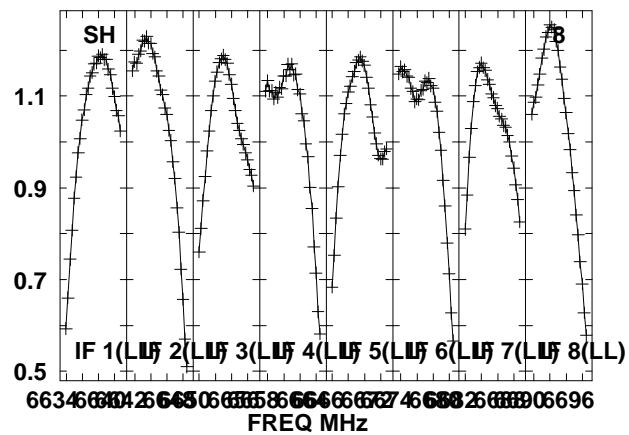
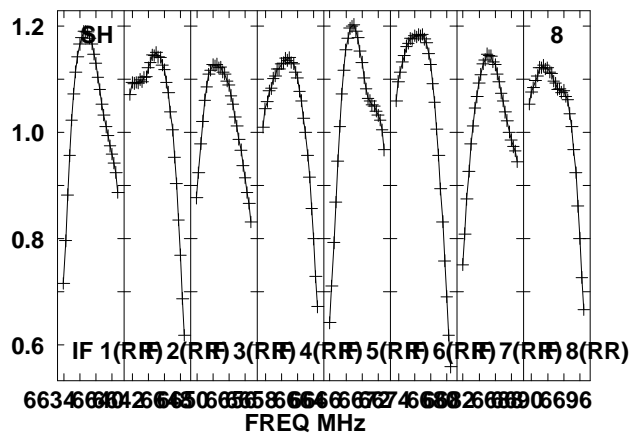
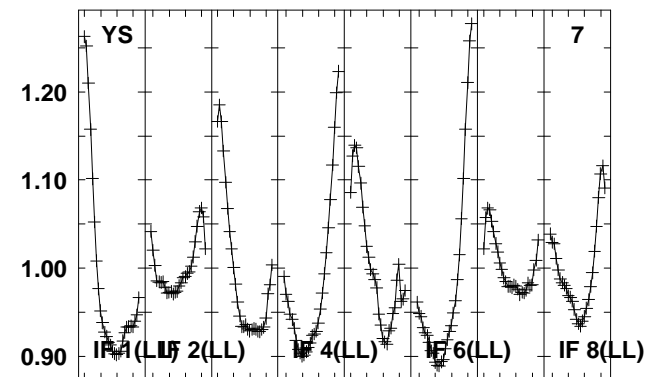
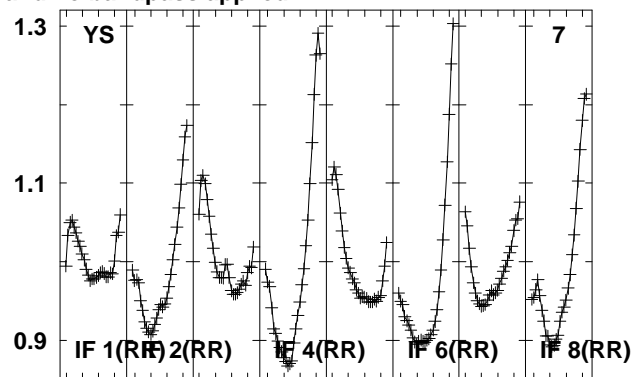
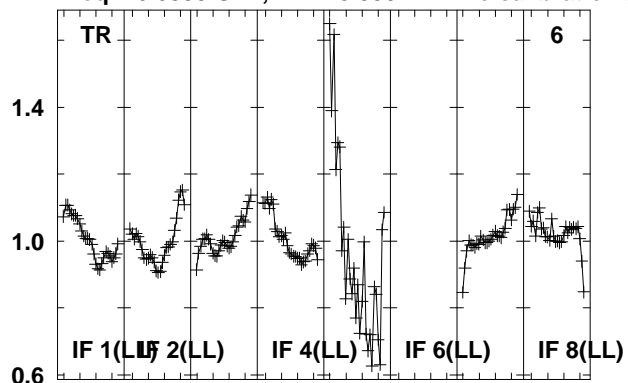

Lower frame: Real Jy
Total-power spectrum Antenna: *
Timerange: 00/11:26:24 to 00/11:27:52

Plot file version 73 created 15-MAR-2012 17:31:13

G85.40 EZ20E 2.UVDATA.1

Freq = 6.6335 GHz, Bw = 8.000 MH No calibration applied and no bandpass applied

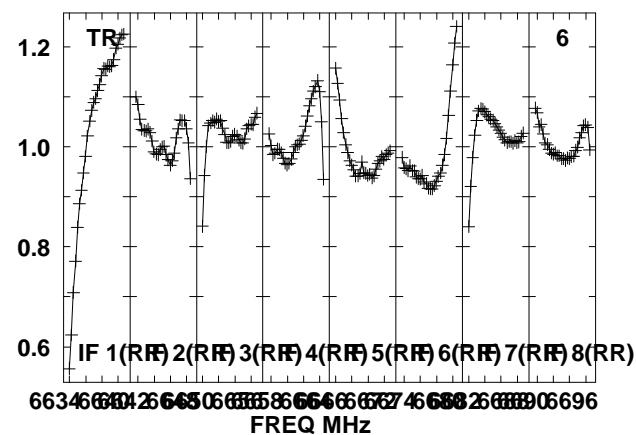
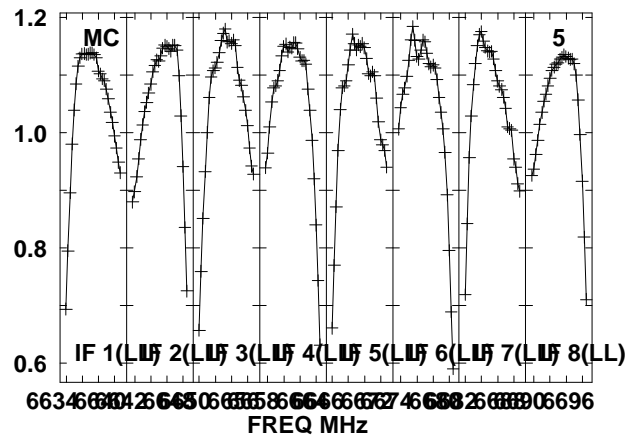
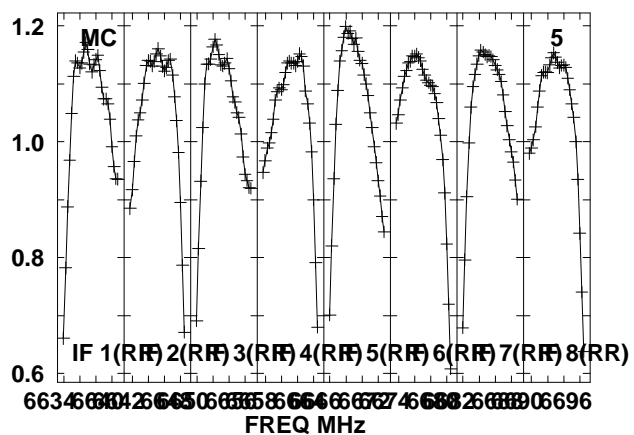
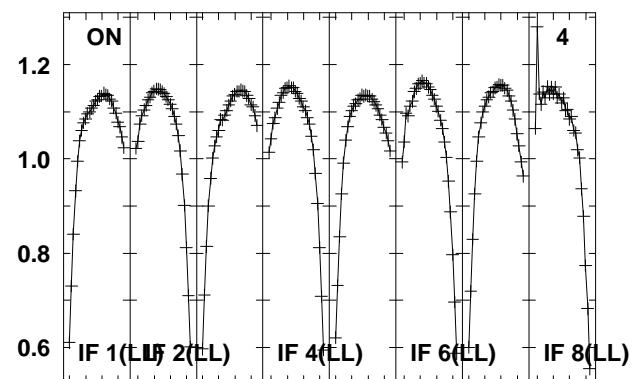
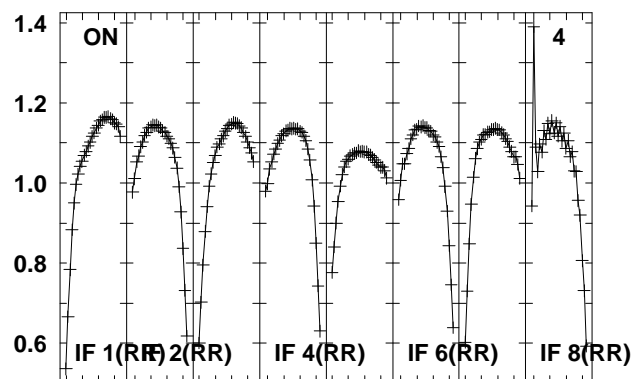
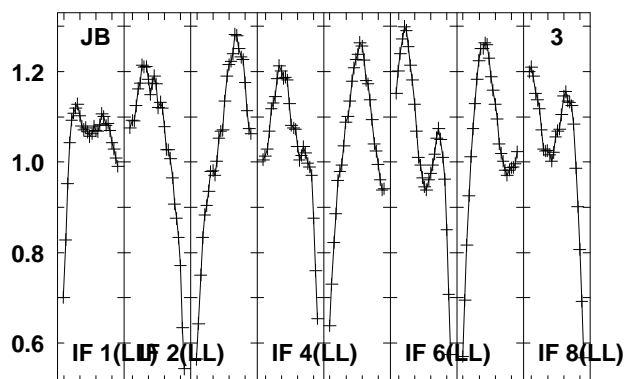
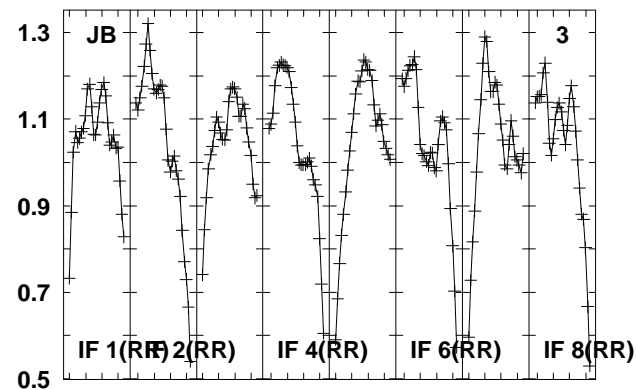
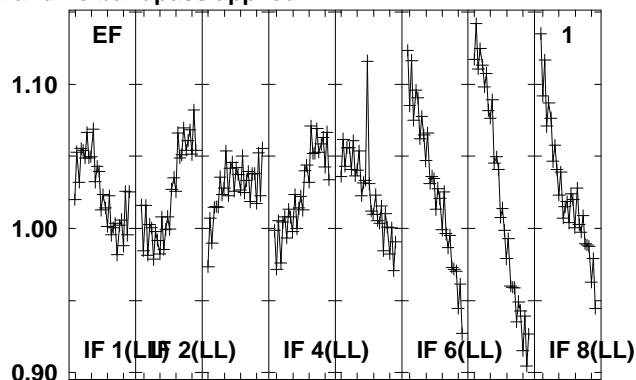
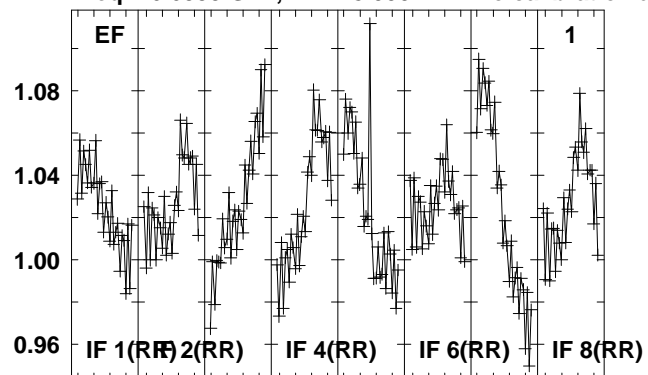

Lower frame: Real Jy
Total-power spectrum Antenna: *
Timerange: 00/11:27:55 to 00/11:29:23

Plot file version 74 created 15-MAR-2012 17:31:14

G85.40 EZ020E 2.UVDATA.1

Freq = 6.6335 GHz, Bw = 8.000 MH No calibration applied and no bandpass applied

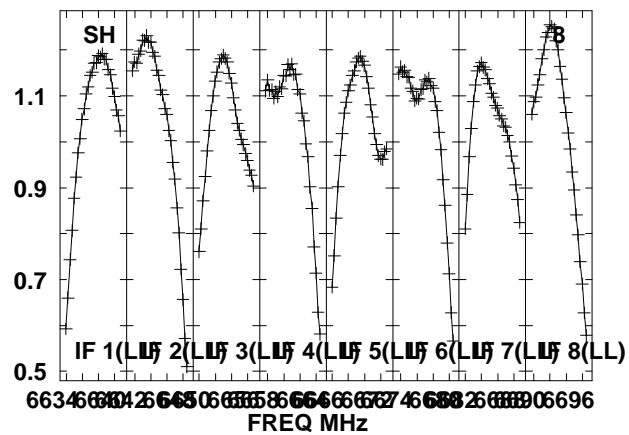
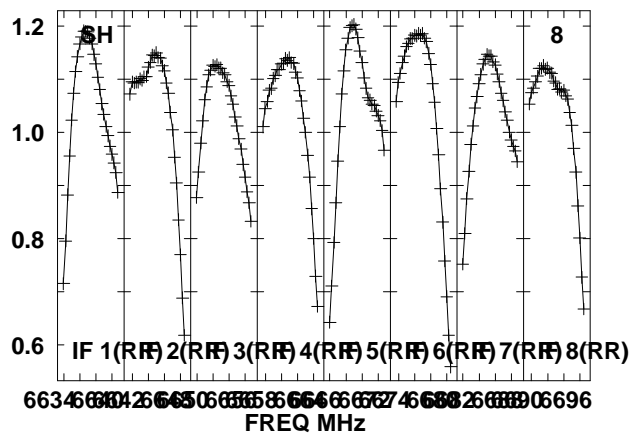
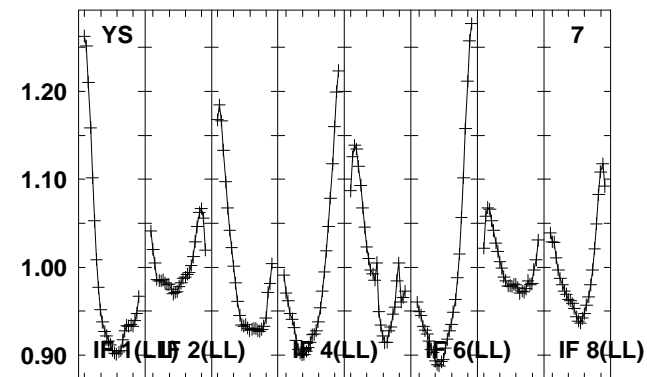
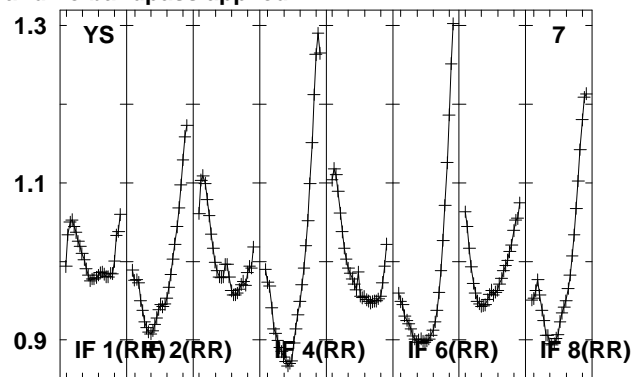
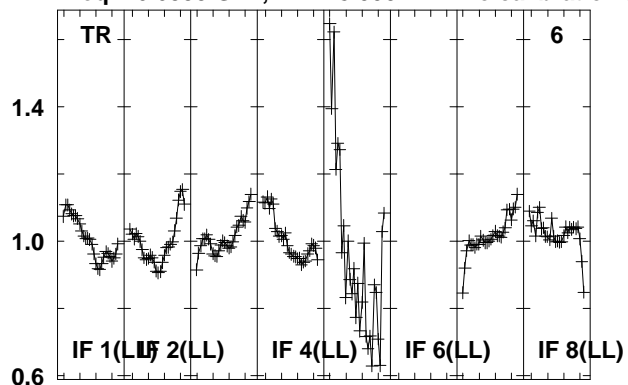

Lower frame: Real Jy
Total-power spectrum Antenna: *
Timerange: 00/11:27:55 to 00/11:29:23

Plot file version 75 created 15-MAR-2012 17:31:15
 2114-G85 EZ020E 2.UVDATA.1
 Freq = 6.6335 GHz, Bw = 8.000 MH No calibration applied and no bandpass applied

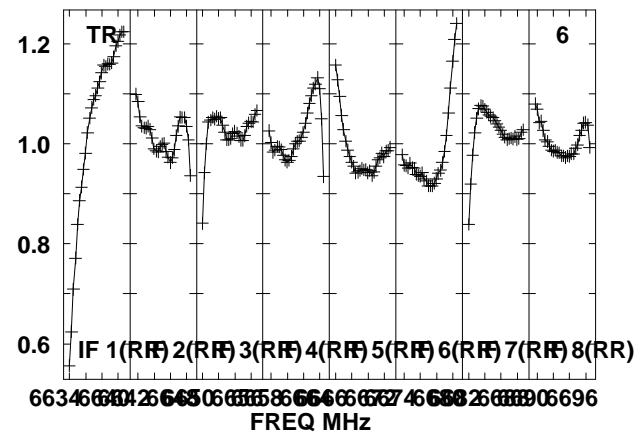
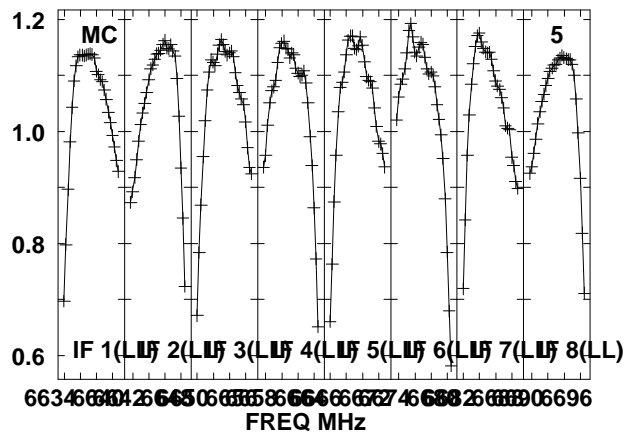
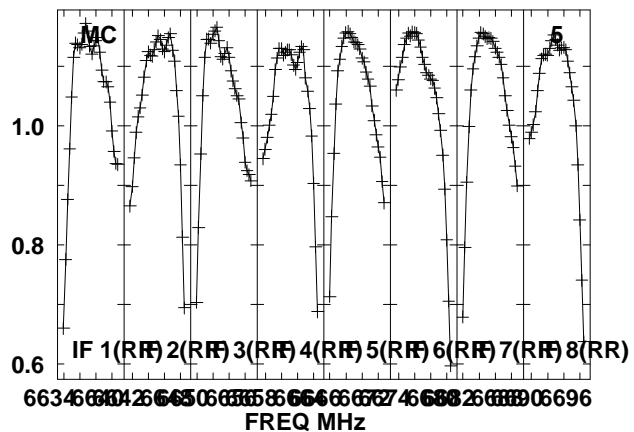
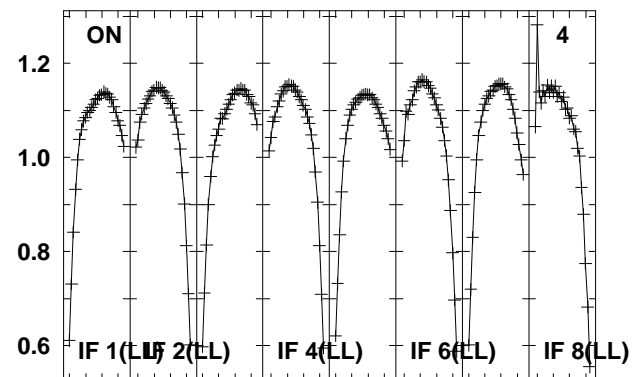
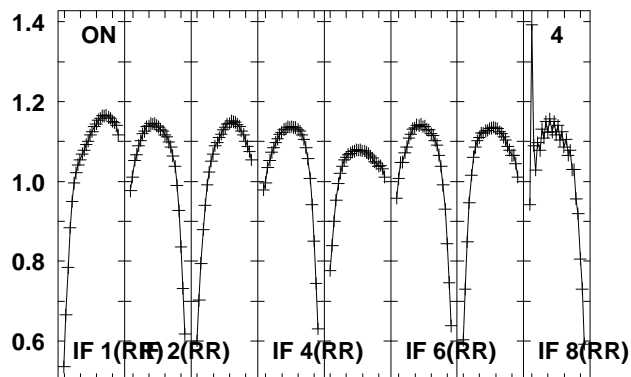
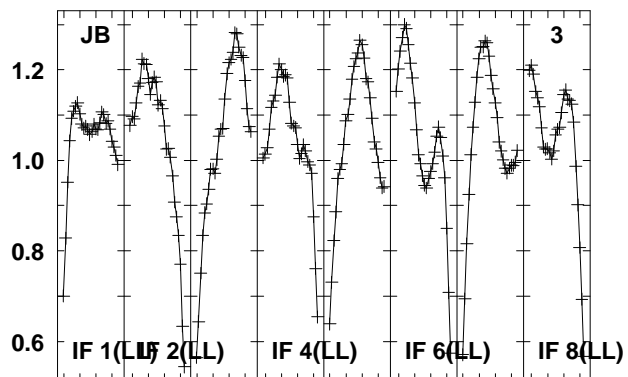
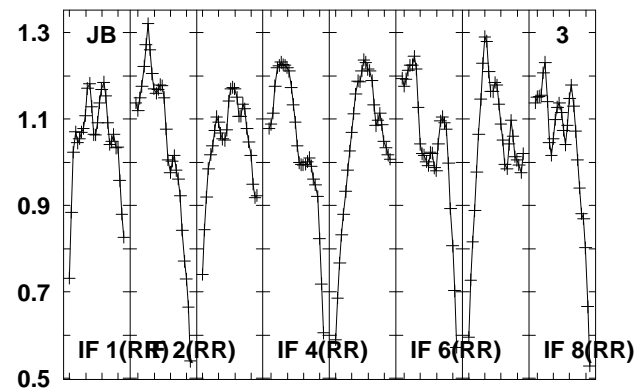
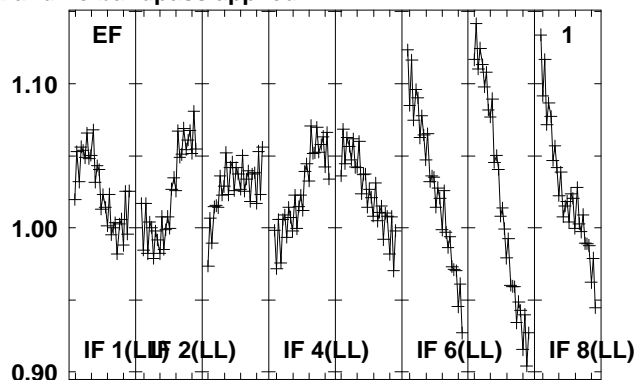
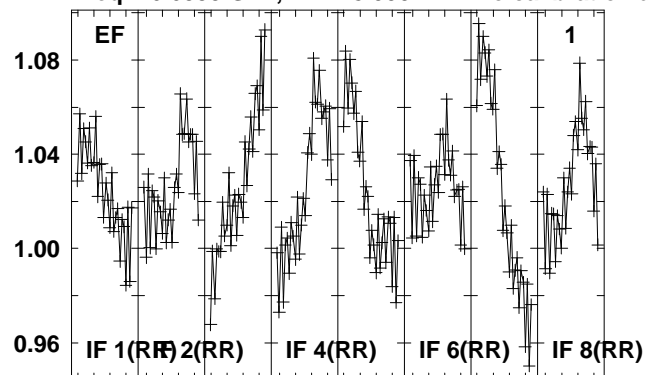

Lower frame: Real Jy
 Total-power spectrum Antenna: *
 Timerange: 00/11:29:24 to 00/11:30:52

Plot file version 76 created 15-MAR-2012 17:31:15

2114-G85 EZ020E 2.UVDATA.1

Freq = 6.6335 GHz, Bw = 8.000 MH No calibration applied and no bandpass applied

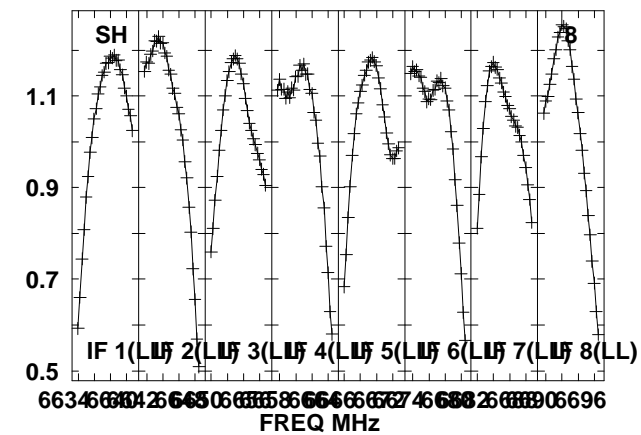
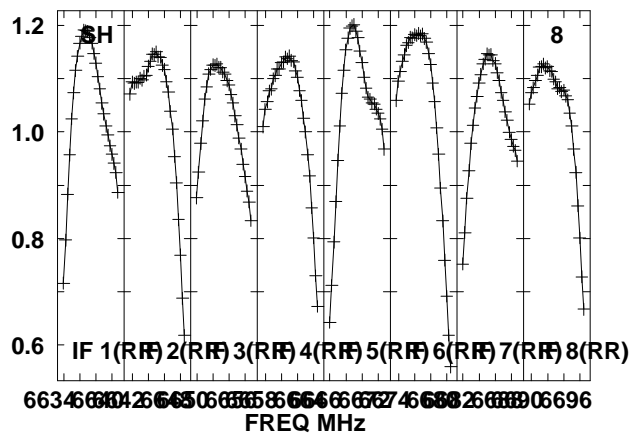
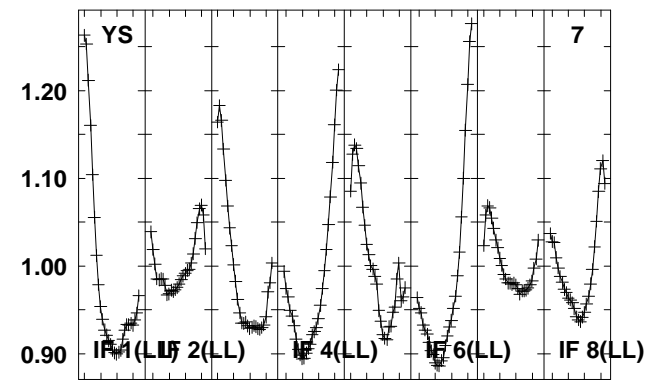
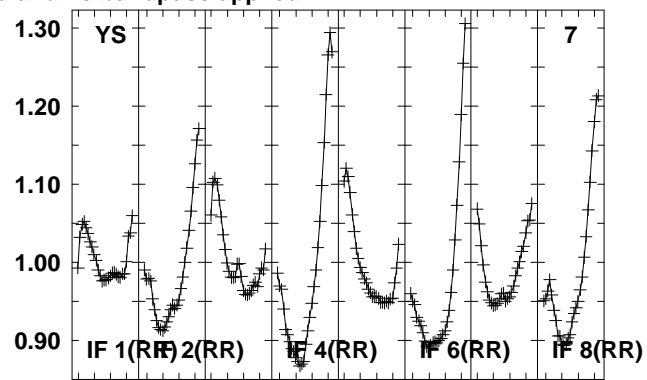
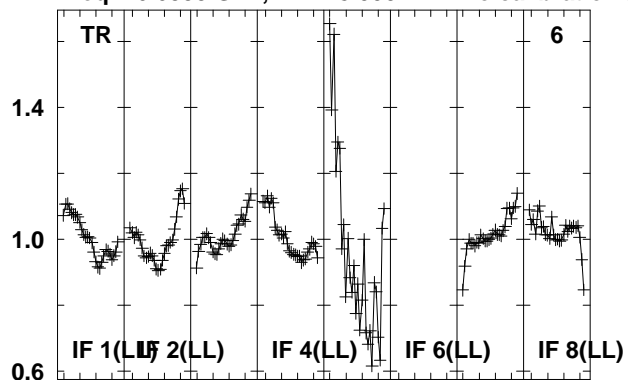

Lower frame: Real Jy
Total-power spectrum Antenna: *
Timerange: 00/11:29:24 to 00/11:30:52

Plot file version 77 created 15-MAR-2012 17:31:16

G85.40 EZ20E 2.UVDATA.1

Freq = 6.6335 GHz, Bw = 8.000 MH No calibration applied and no bandpass applied

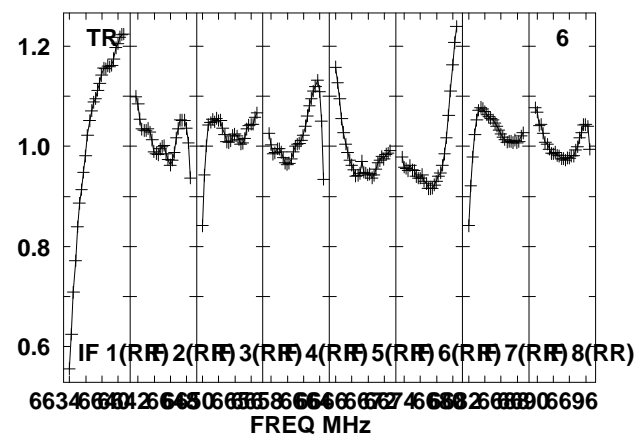
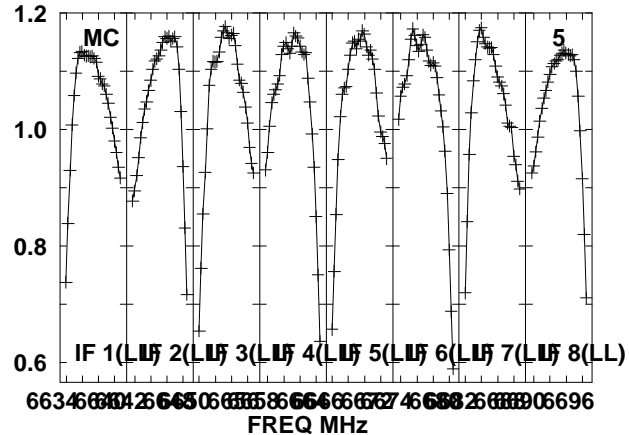
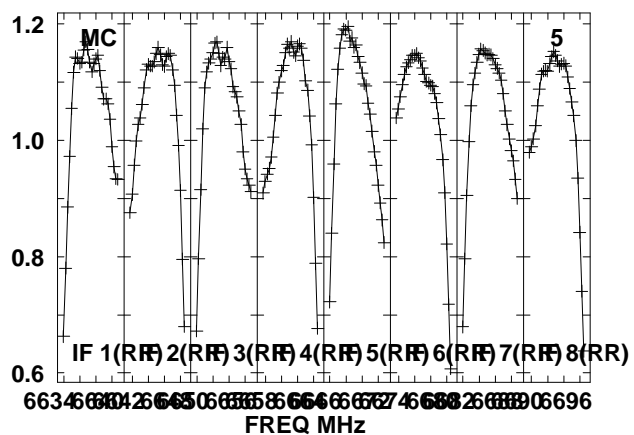
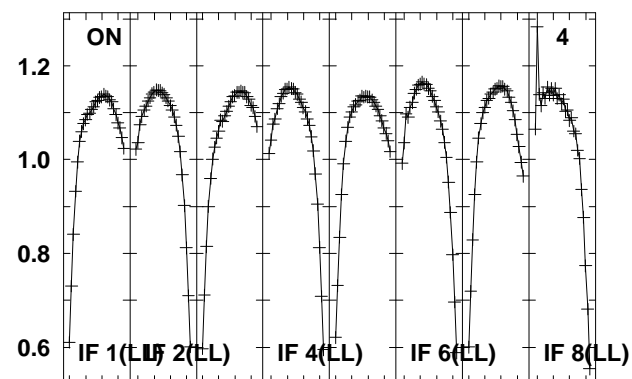
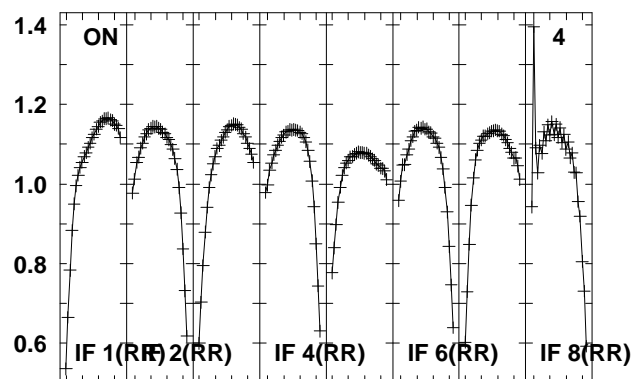
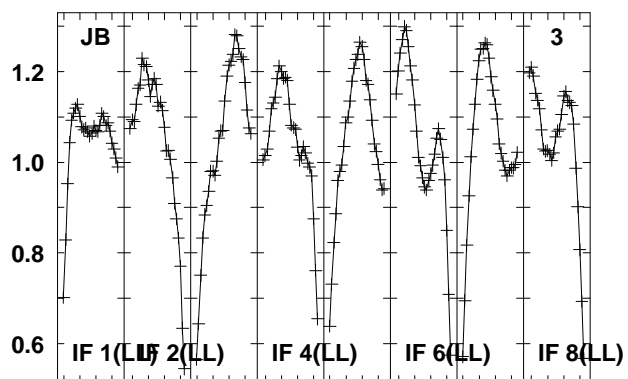
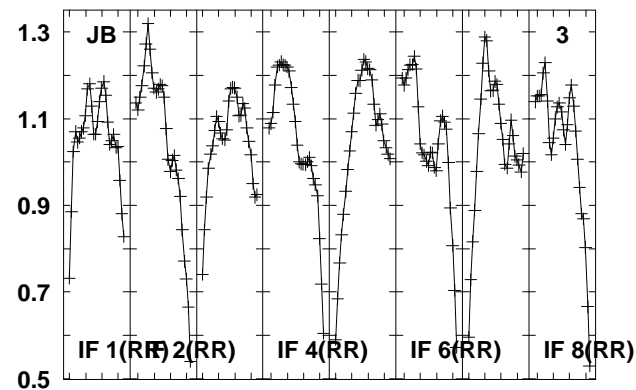
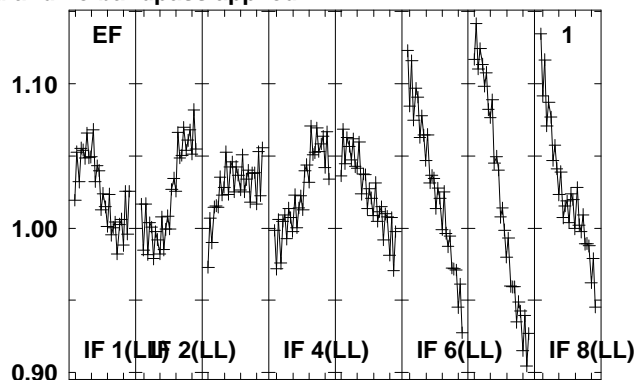
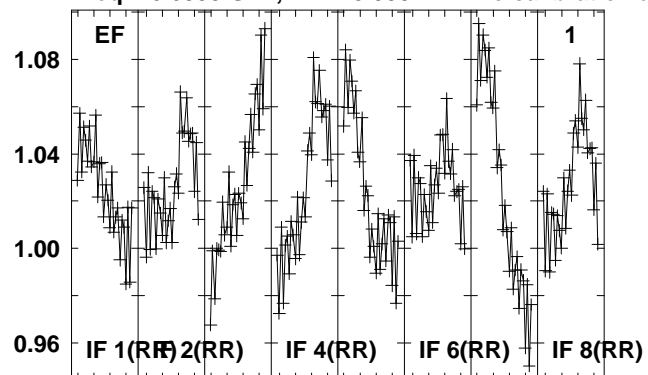

Lower frame: Real Jy
Total-power spectrum Antenna: *
Timerange: 00/11:30:54 to 00/11:32:23

Plot file version 78 created 15-MAR-2012 17:31:17

G85.40 EZ020E 2.UVDATA.1

Freq = 6.6335 GHz, Bw = 8.000 MH No calibration applied and no bandpass applied

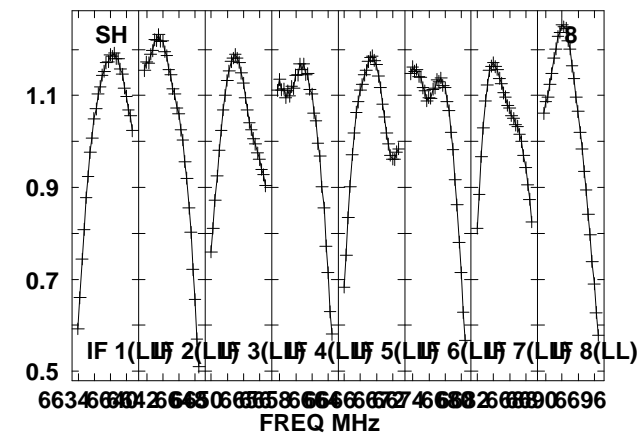
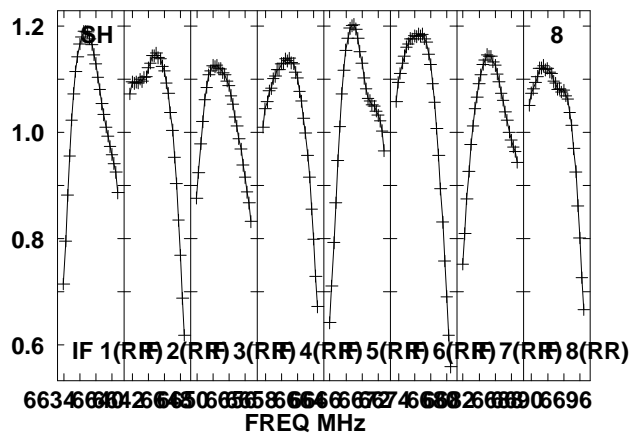
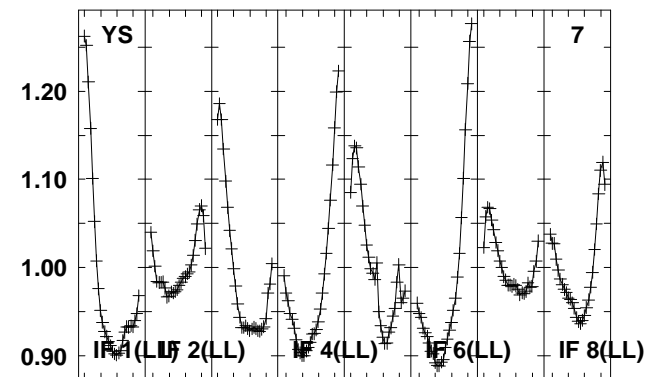
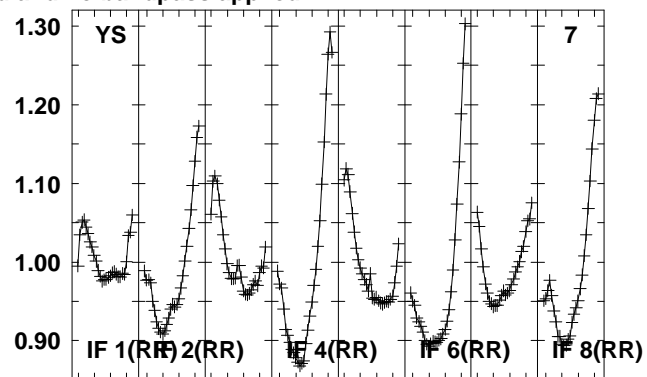
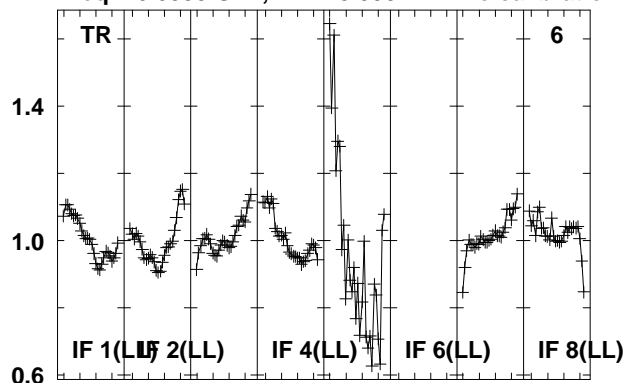

Lower frame: Real Jy
Total-power spectrum Antenna: *
Timerange: 00/11:30:54 to 00/11:32:23

Plot file version 79 created 15-MAR-2012 17:31:17
 2102-G85 EZ020E 2.UVDATA.1
 Freq = 6.6335 GHz, Bw = 8.000 MH No calibration applied and no bandpass applied

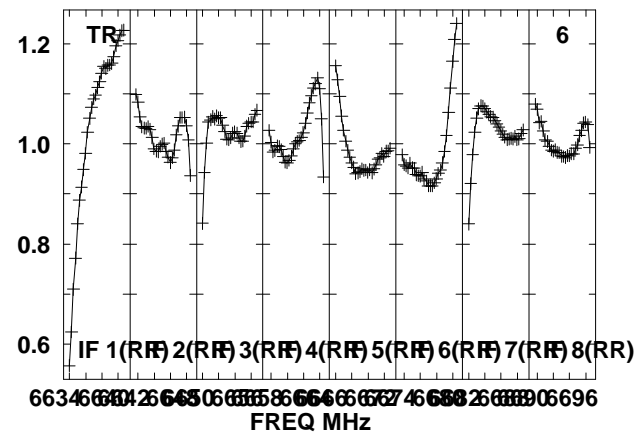
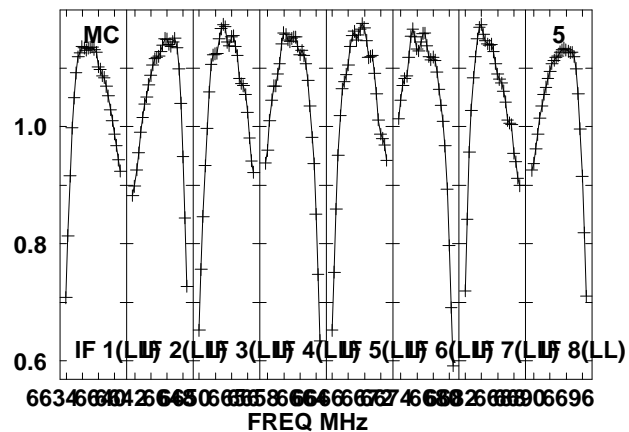
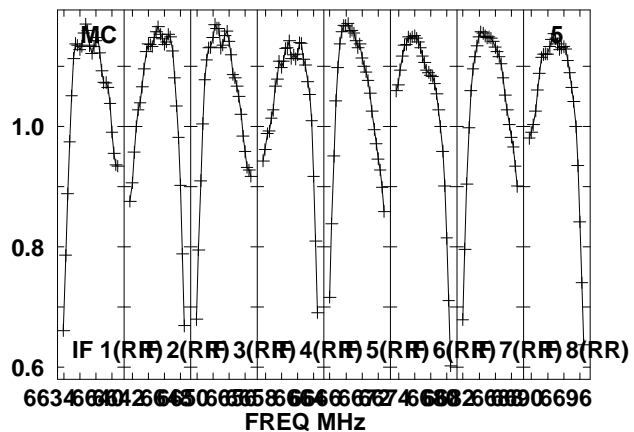
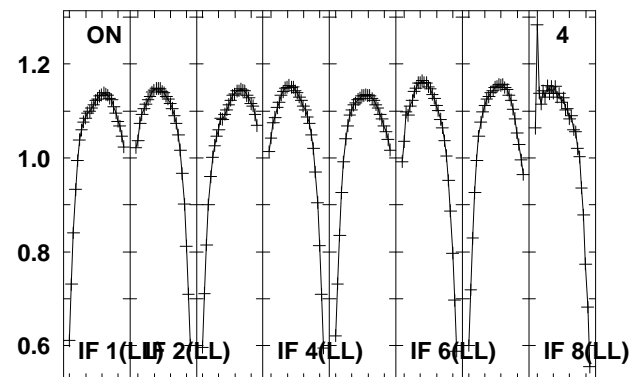
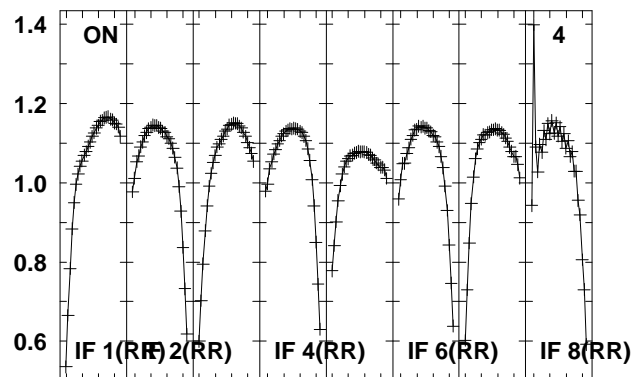
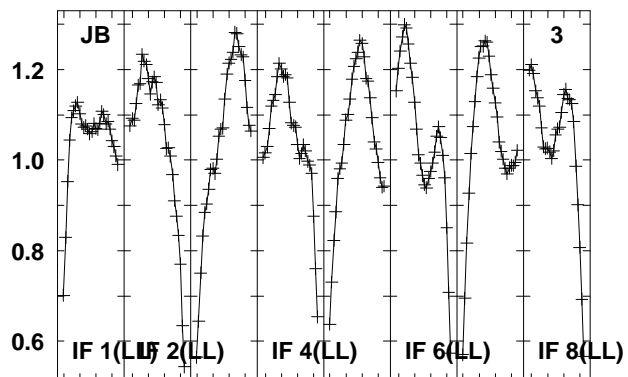
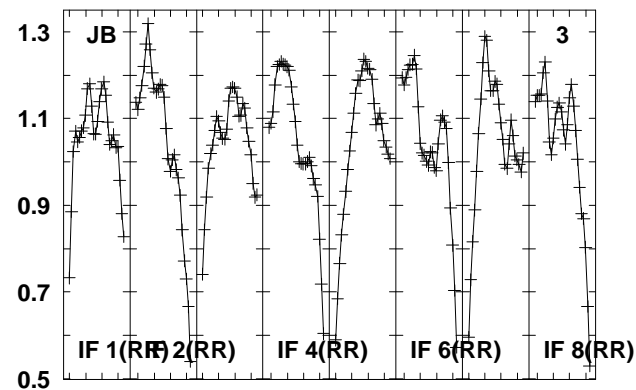
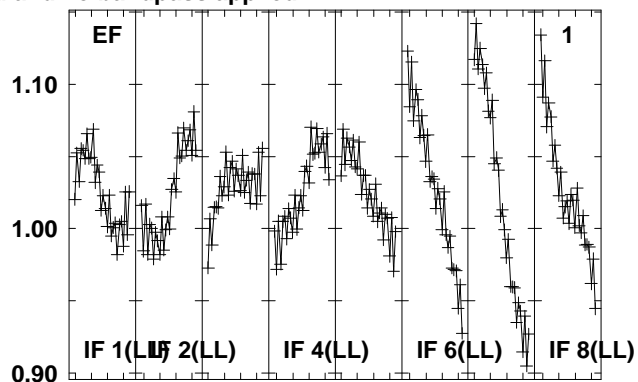
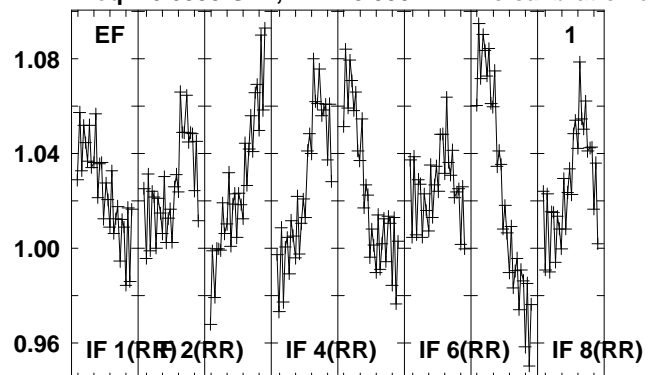

Lower frame: Real Jy
 Total-power spectrum Antenna: *
 Timerange: 00/11:32:25 to 00/11:33:53

Plot file version 80 created 15-MAR-2012 17:31:18

2102-G85 EZ020E 2.UVDATA.1

Freq = 6.6335 GHz, Bw = 8.000 MH No calibration applied and no bandpass applied

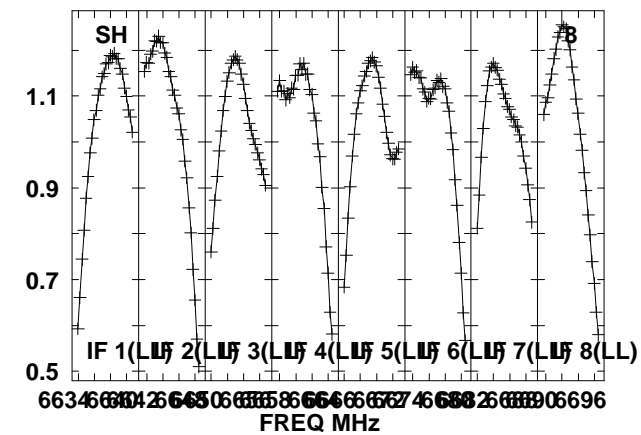
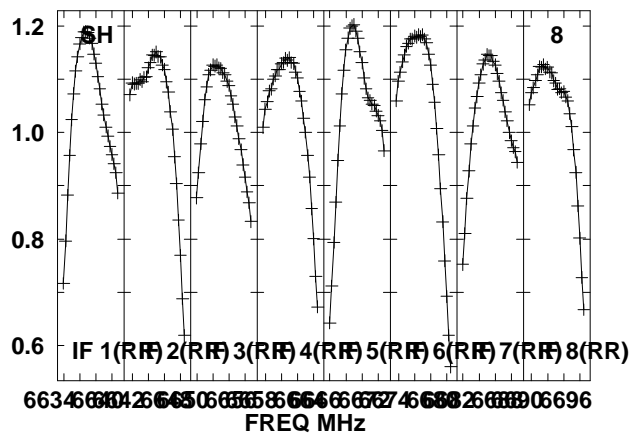
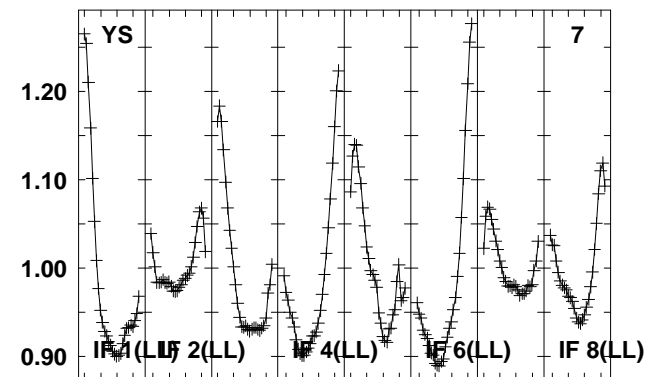
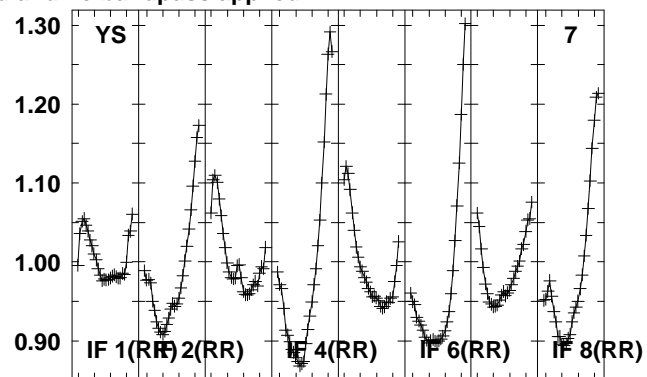
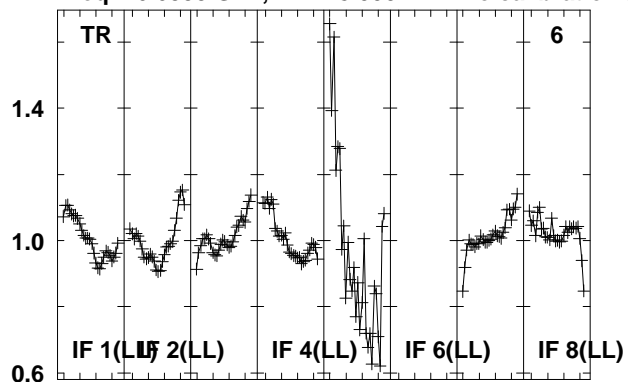

Lower frame: Real Jy
Total-power spectrum Antenna: *
Timerange: 00/11:32:25 to 00/11:33:53

Plot file version 81 created 15-MAR-2012 17:31:19

G85.40 EZ20E 2.UVDATA.1

Freq = 6.6335 GHz, Bw = 8.000 MH No calibration applied and no bandpass applied

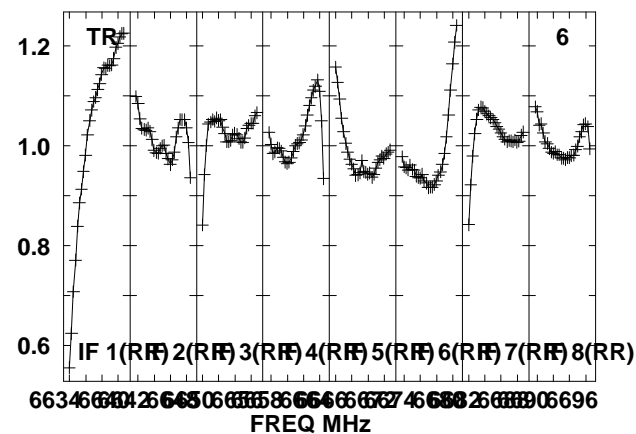
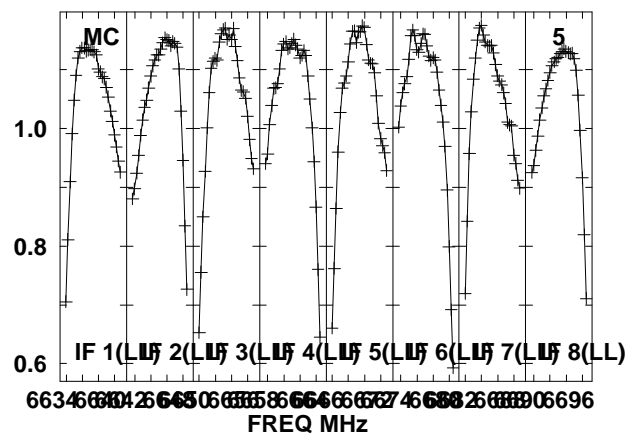
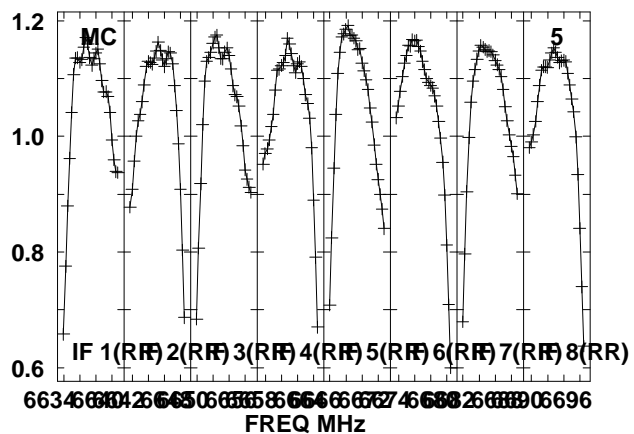
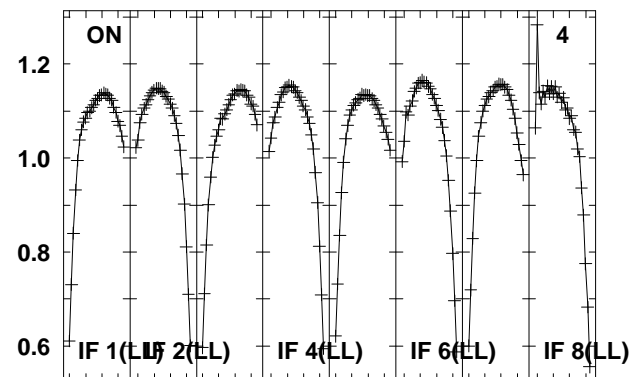
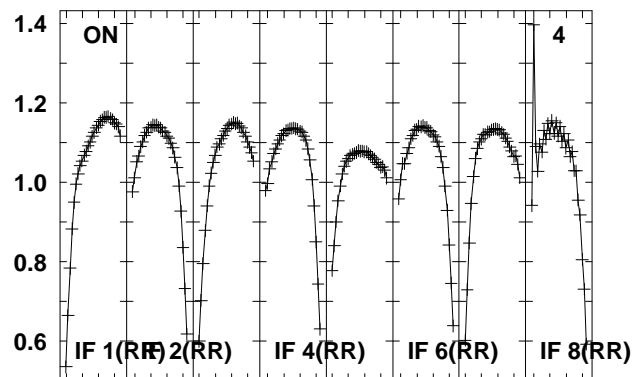
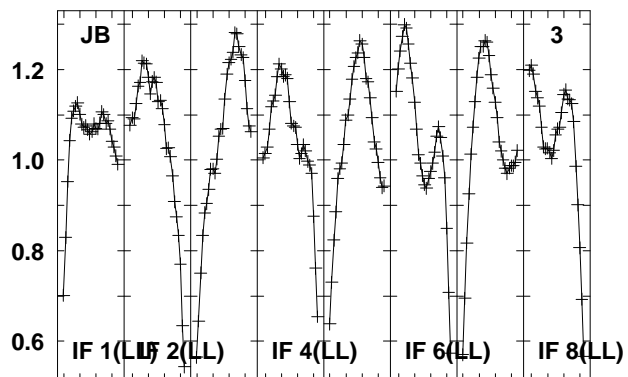
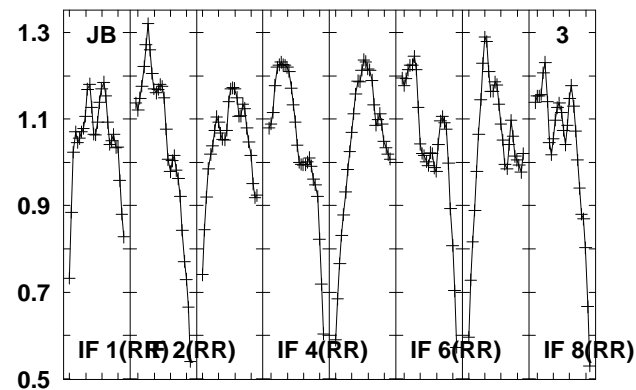
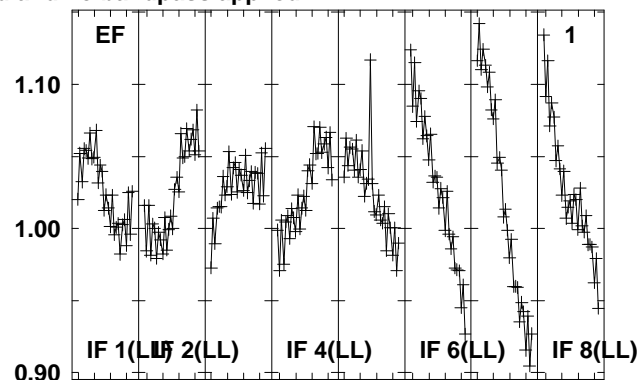
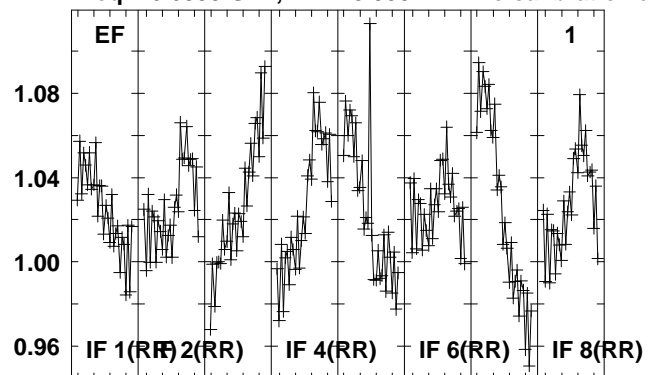

Lower frame: Real Jy
Total-power spectrum Antenna: *
Timerange: 00/11:33:54 to 00/11:35:23

Plot file version 82 created 15-MAR-2012 17:31:19

G85.40 EZ020E 2.UVDATA.1

Freq = 6.6335 GHz, Bw = 8.000 MH No calibration applied and no bandpass applied

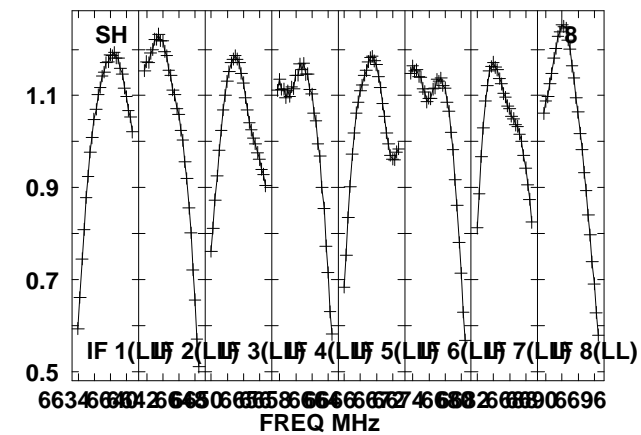
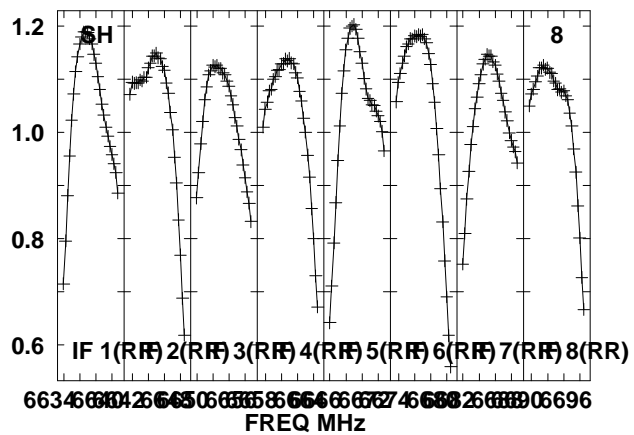
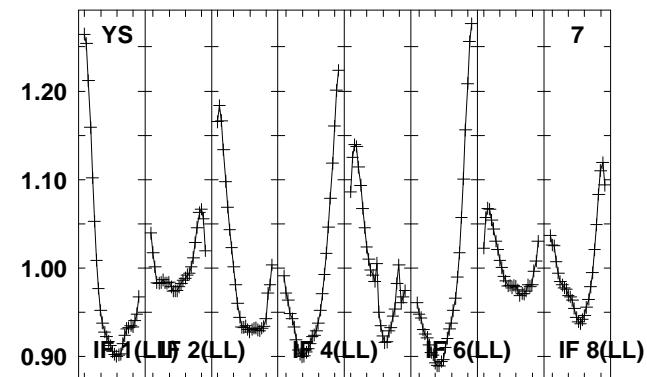
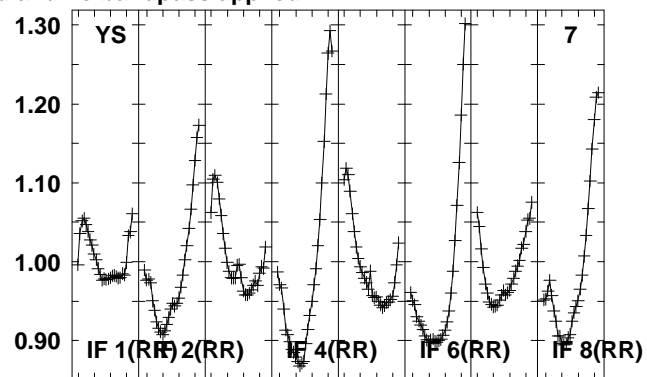
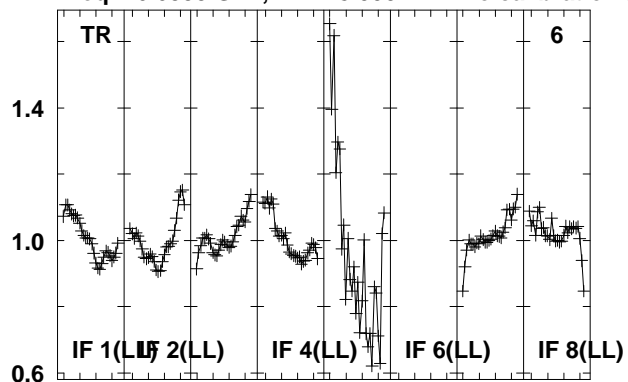

Lower frame: Real Jy
Total-power spectrum Antenna: *
Timerange: 00/11:33:54 to 00/11:35:23

Plot file version 83 created 15-MAR-2012 17:31:21
 2114-G85 EZ020E 2.UVDATA.1
 Freq = 6.6335 GHz, Bw = 8.000 MH No calibration applied and no bandpass applied

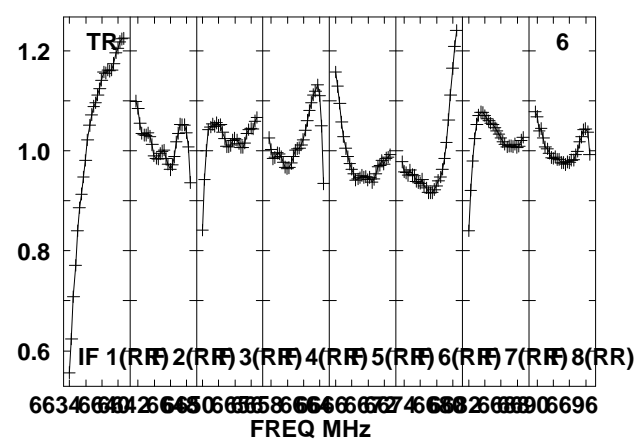
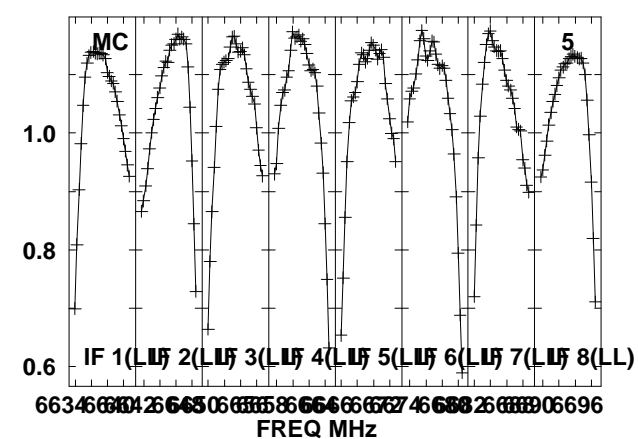
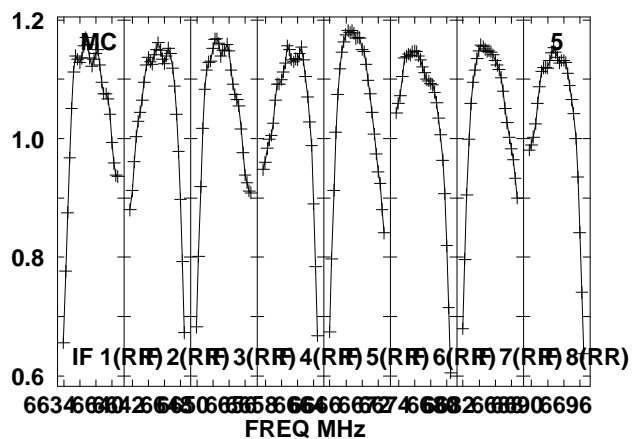
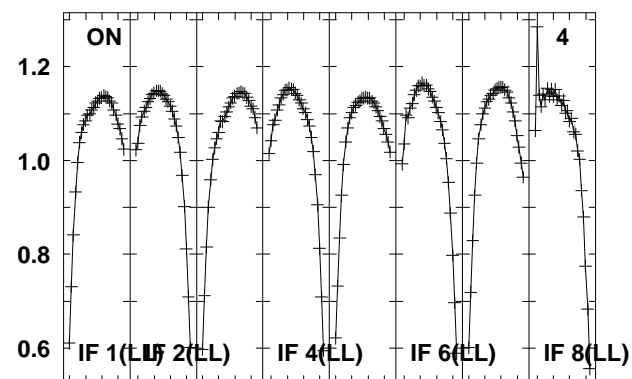
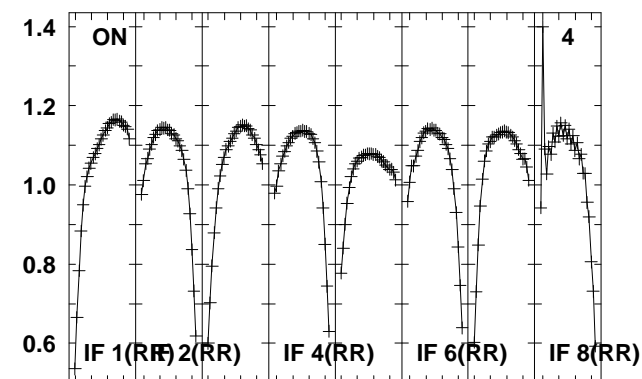
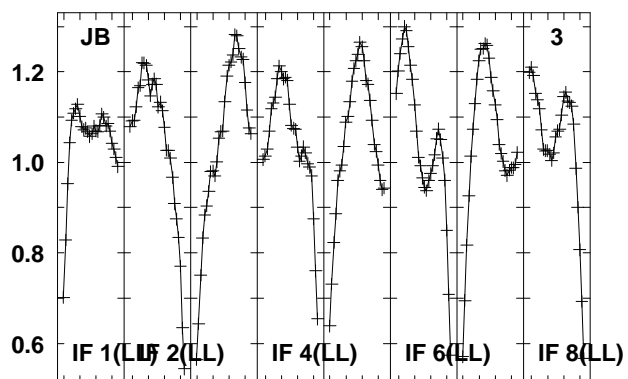
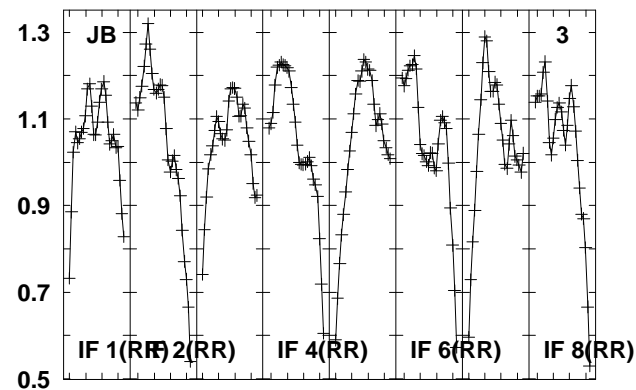
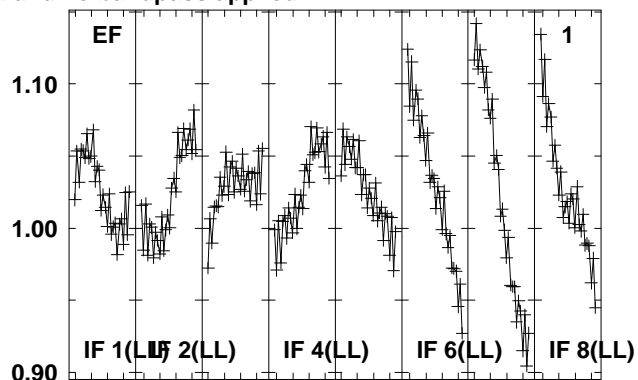
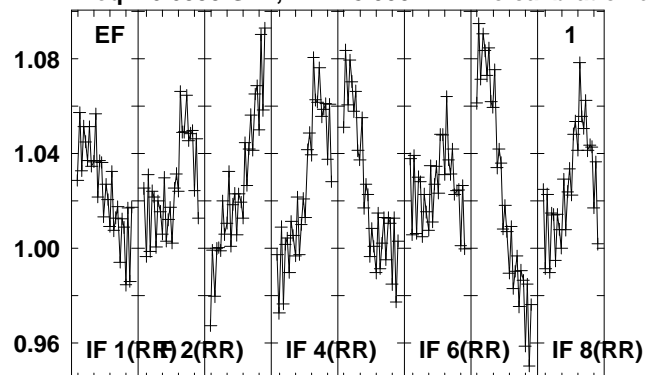

Lower frame: Real Jy
 Total-power spectrum Antenna: *
 Timerange: 00/11:35:24 to 00/11:36:52

Plot file version 84 created 15-MAR-2012 17:31:21

2114-G85 EZ020E 2.UVDATA.1

Freq = 6.6335 GHz, Bw = 8.000 MH No calibration applied and no bandpass applied

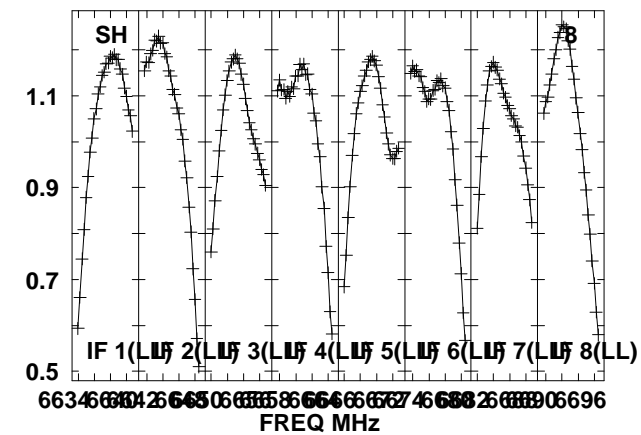
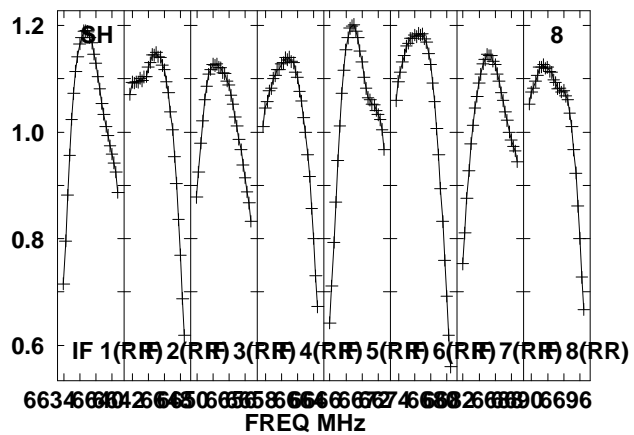
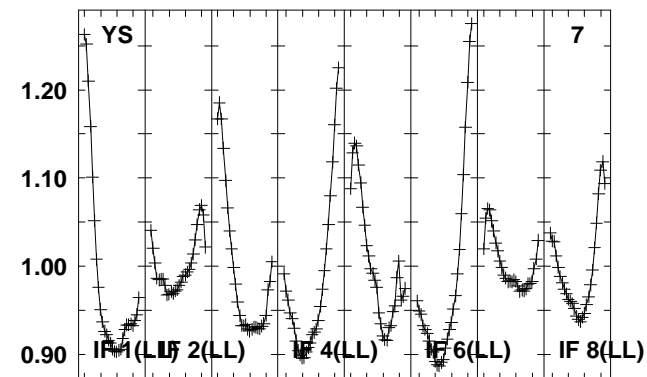
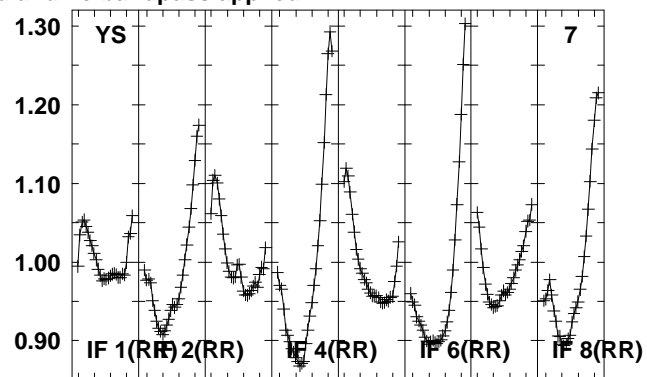
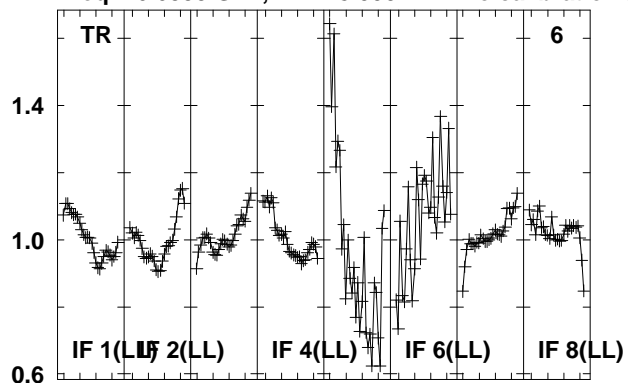

Lower frame: Real Jy
Total-power spectrum Antenna: *
Timerange: 00/11:35:24 to 00/11:36:52

Plot file version 85 created 15-MAR-2012 17:31:22

G85.40 EZ020E 2.UVDATA.1

Freq = 6.6335 GHz, Bw = 8.000 MH No calibration applied and no bandpass applied

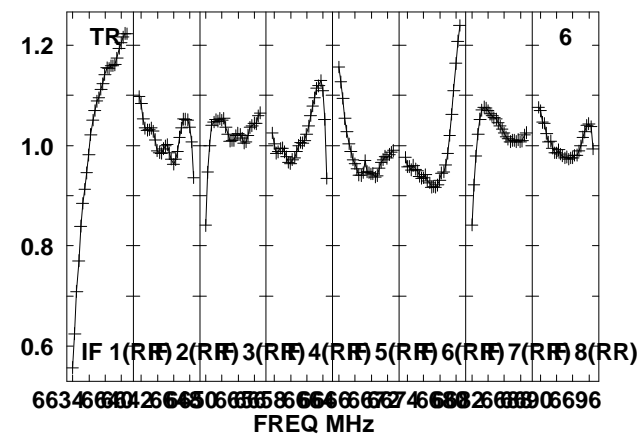
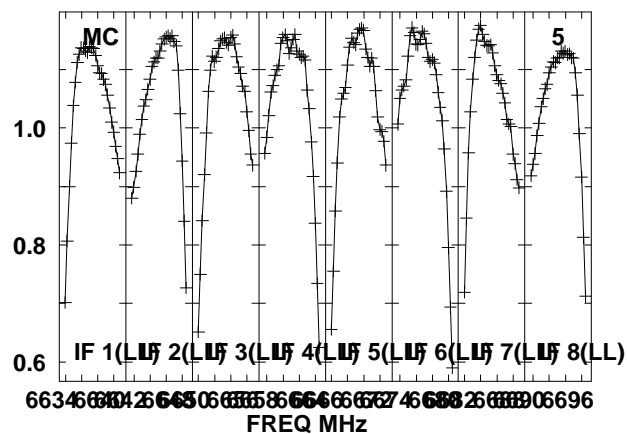
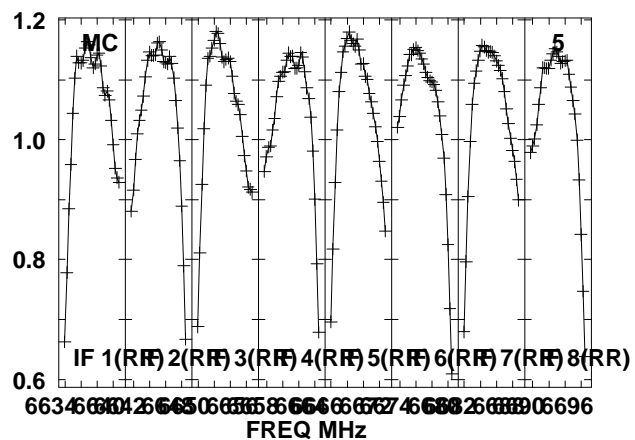
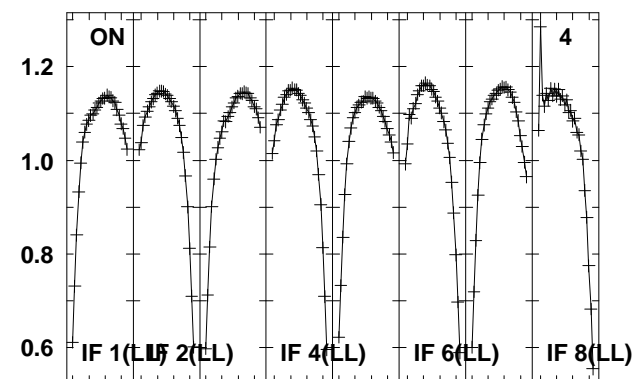
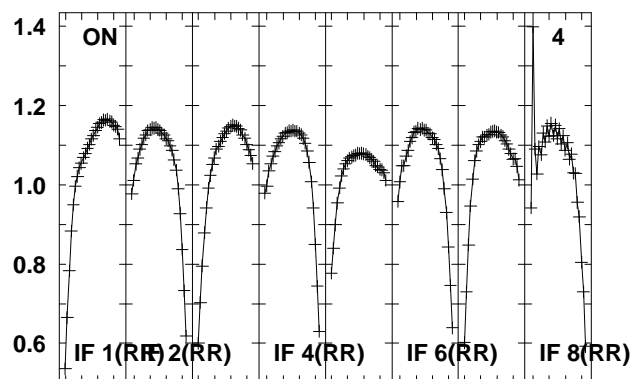
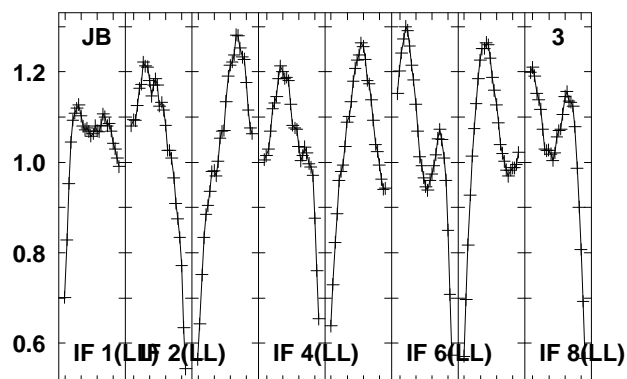
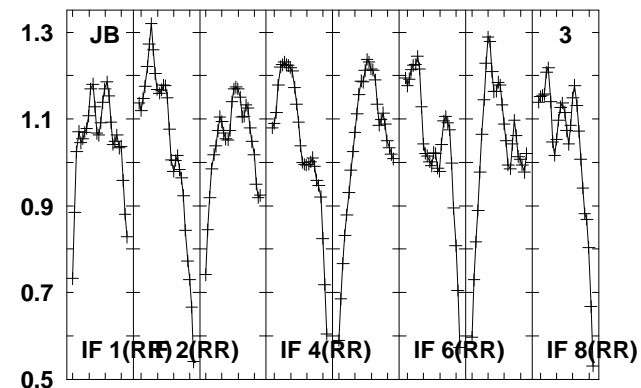
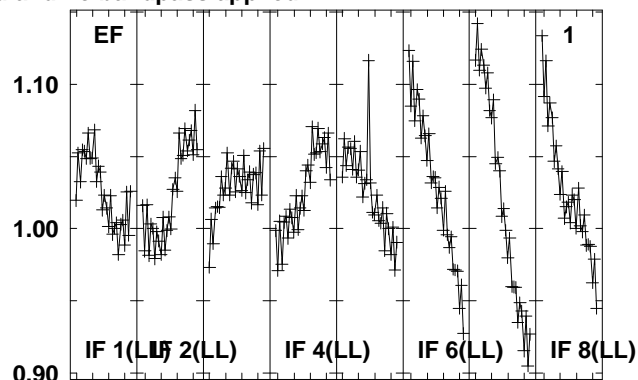
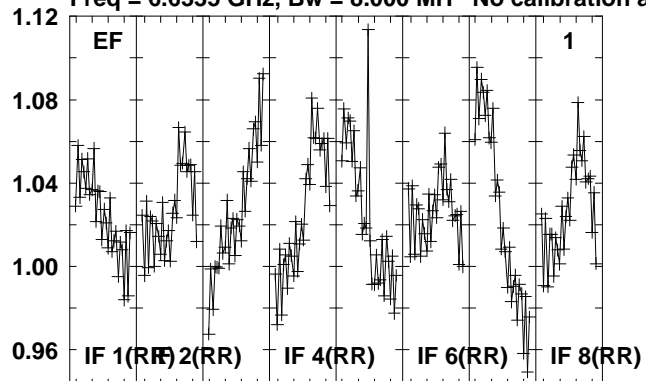

Lower frame: Real Jy
Total-power spectrum Antenna: *
Timerange: 00/11:37:34 to 00/11:38:31

Plot file version 86 created 15-MAR-2012 17:31:22

G85.40 EZ020E 2.UVDATA.1

Freq = 6.6335 GHz, Bw = 8.000 MH No calibration applied and no bandpass applied

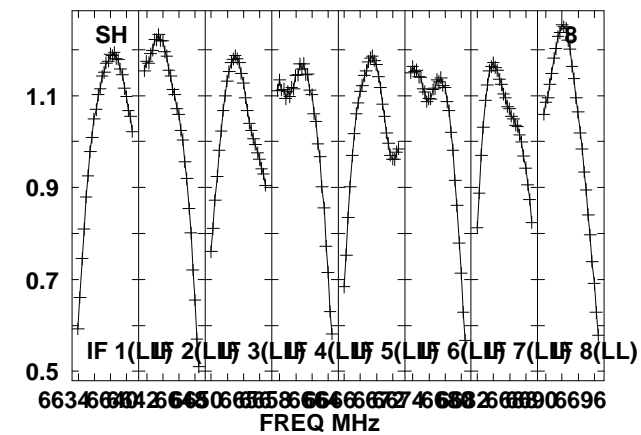
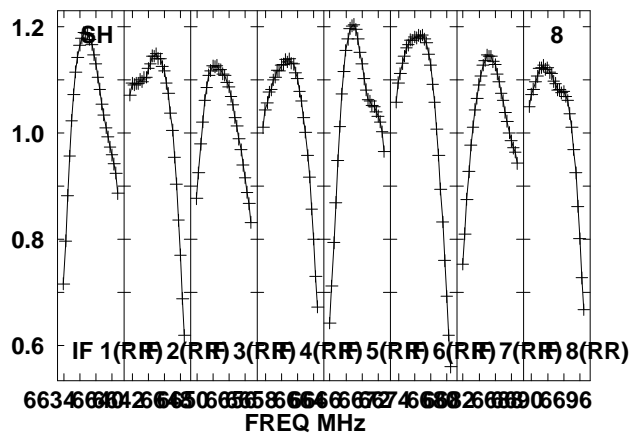
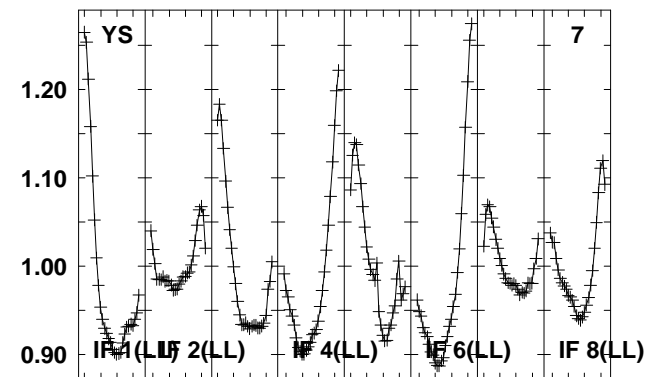
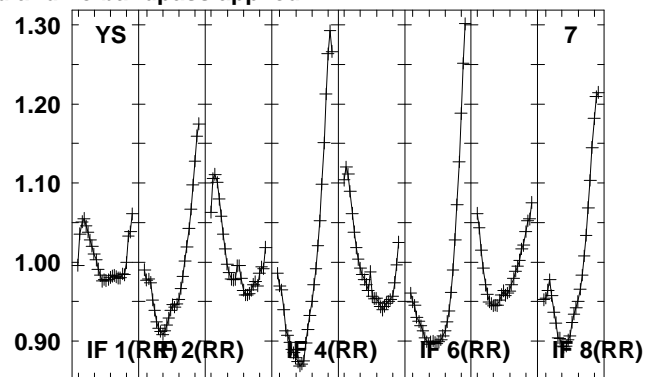
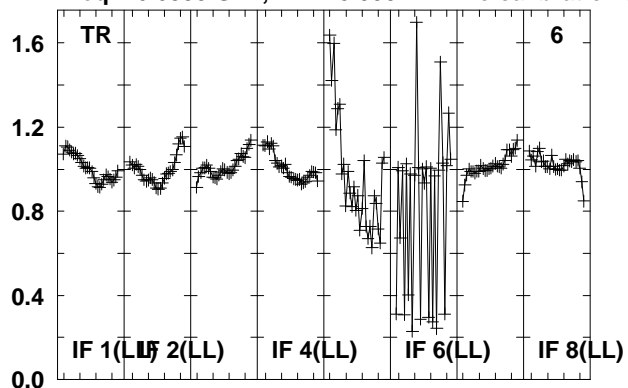

Lower frame: Real Jy
Total-power spectrum Antenna: *
Timerange: 00/11:37:34 to 00/11:38:31

Plot file version 87 created 15-MAR-2012 17:31:23

G85.40 EZ020E 2.UVDATA.1

Freq = 6.6335 GHz, Bw = 8.000 MH No calibration applied and no bandpass applied

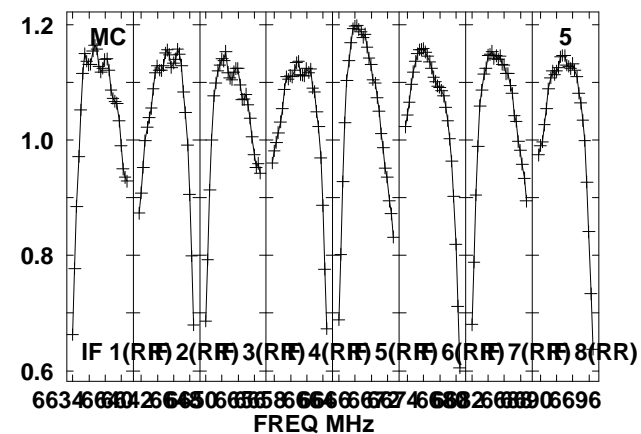
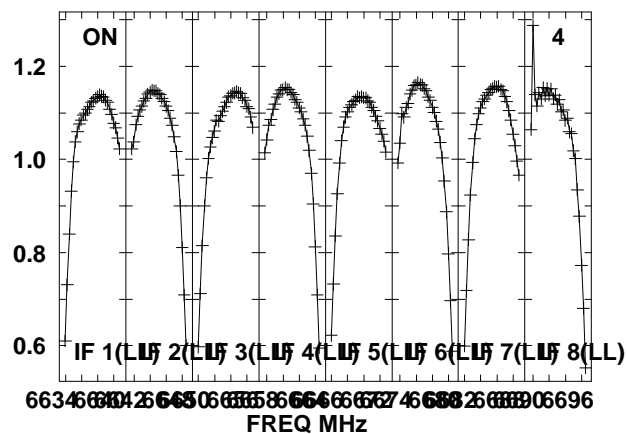
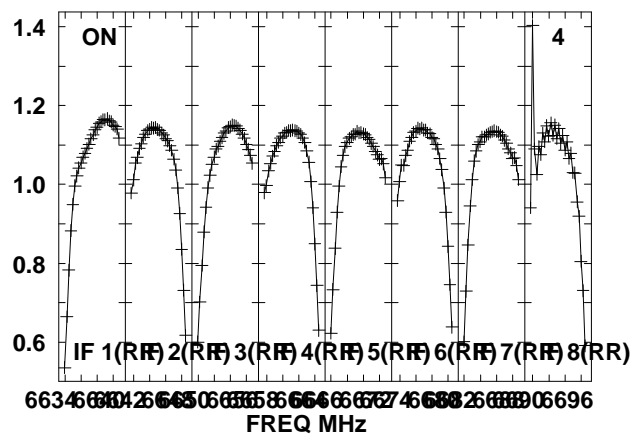
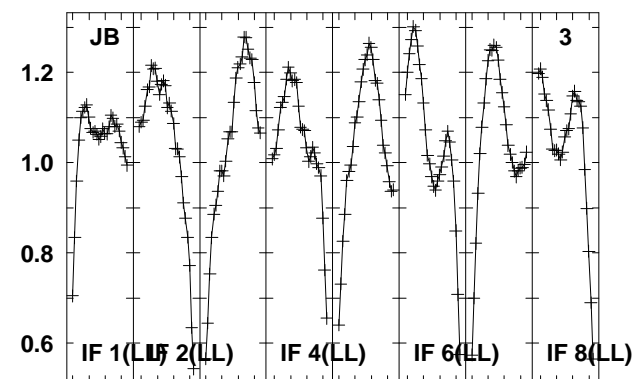
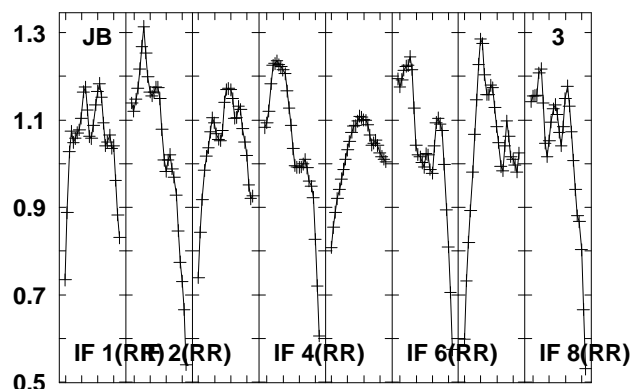
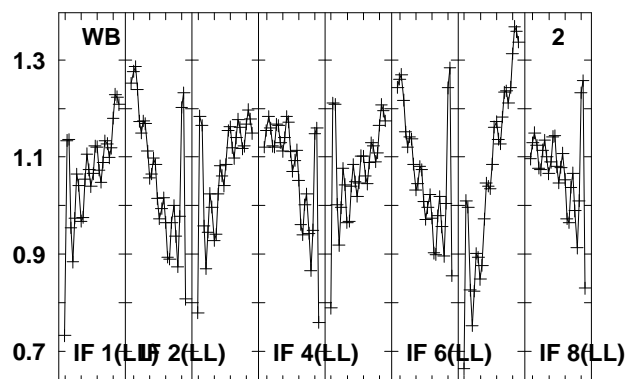
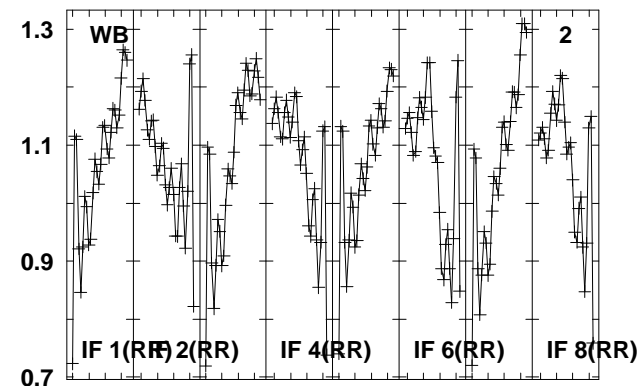
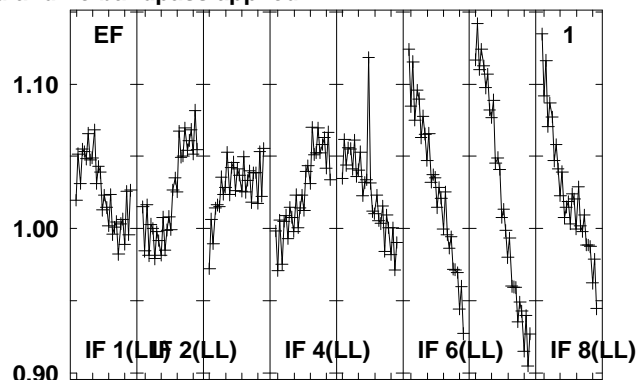
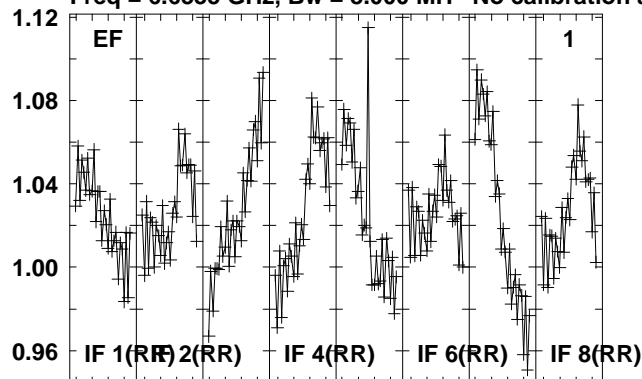

Lower frame: Real Jy

Total-power spectrum Antenna: *

Timerange: 00/12:11:21 to 00/12:12:20

Plot file version 88 created 15-MAR-2012 17:31:23

G85.40 EZ020E 2.UVDATA.1

Freq = 6.6335 GHz, Bw = 8.000 MH No calibration applied and no bandpass applied

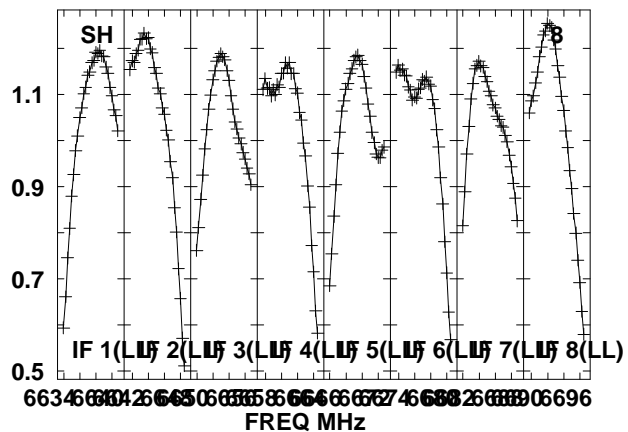
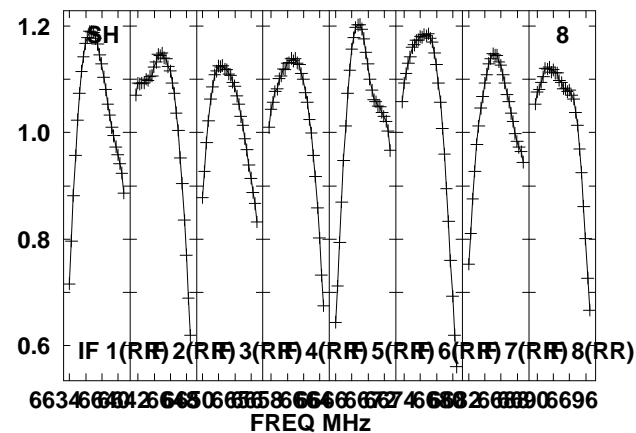
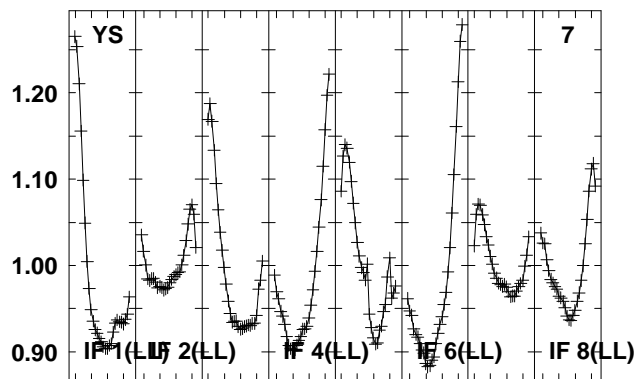
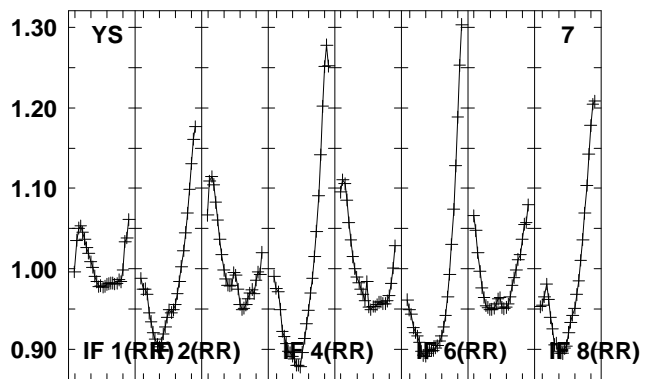
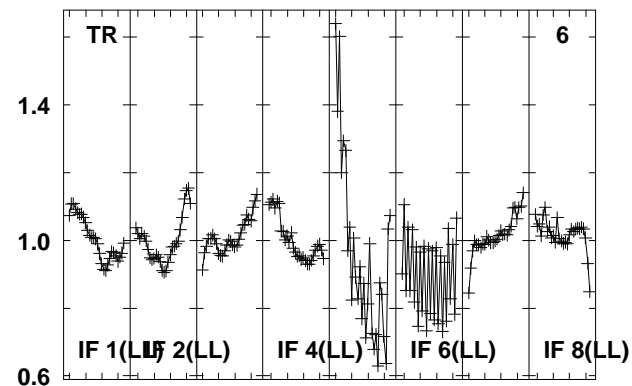
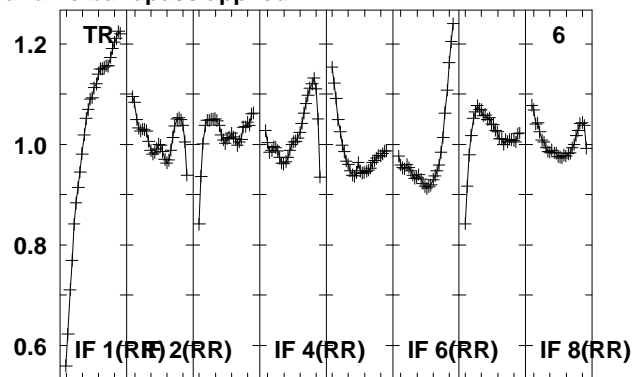
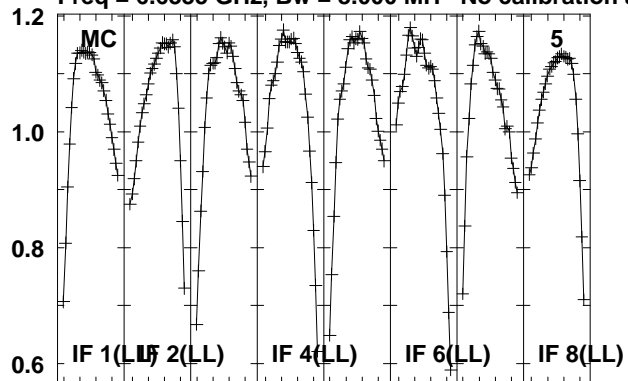

Lower frame: Real Jy

Total-power spectrum Antenna: *

Timerange: 00/12:11:21 to 00/12:12:20

Plot file version 89 created 15-MAR-2012 17:31:24
 2102-G85 EZ020E 2.UVDATA.1
 Freq = 6.6335 GHz, Bw = 8.000 MH No calibration applied and no bandpass applied

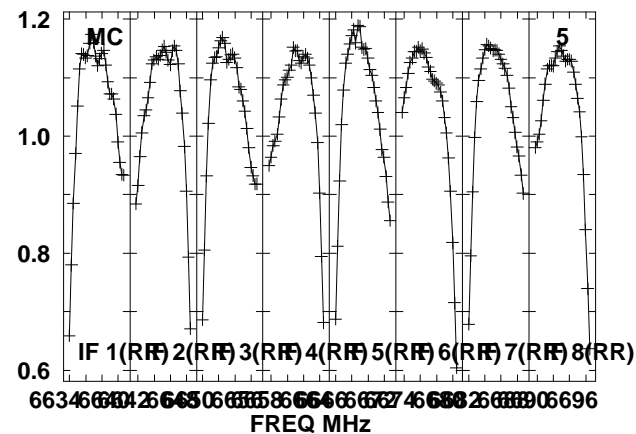
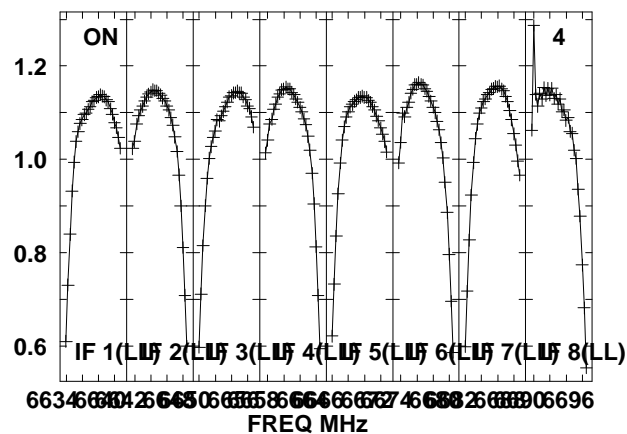
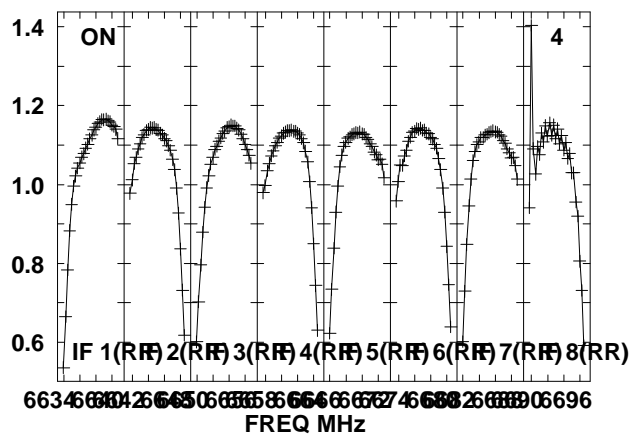
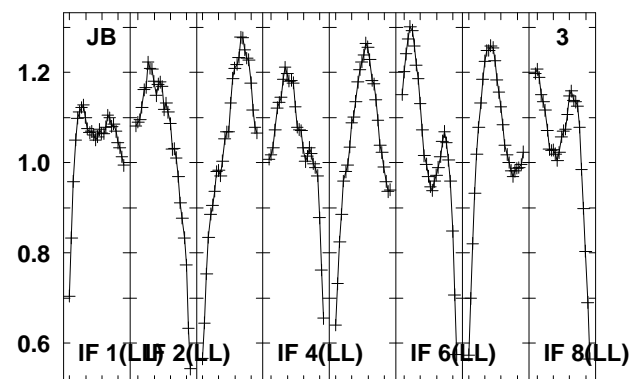
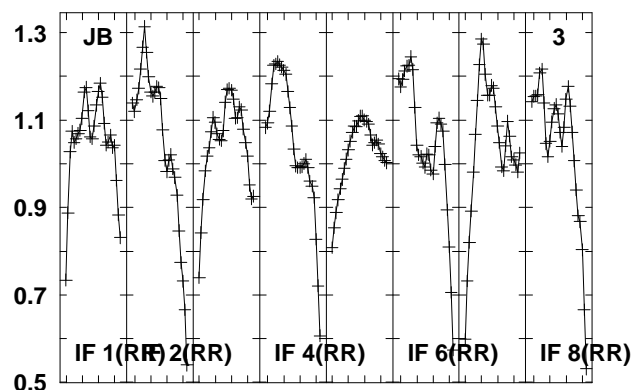
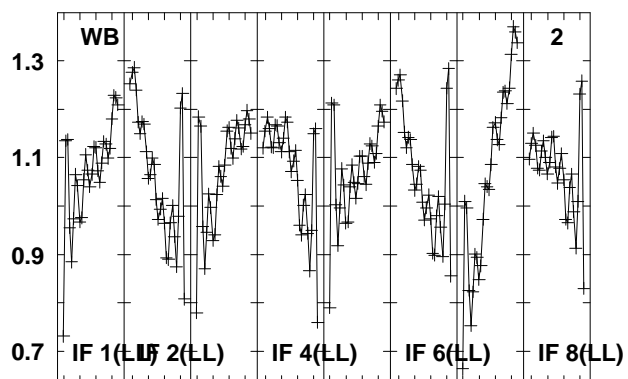
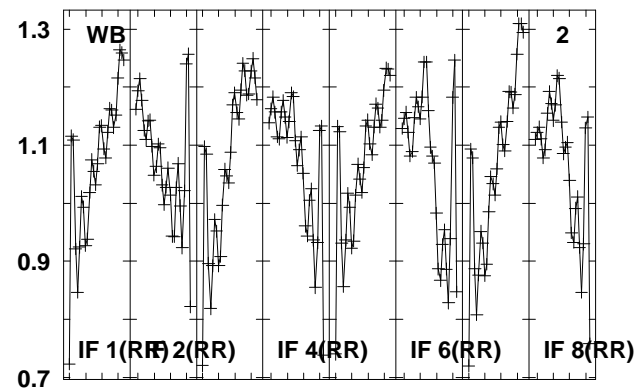
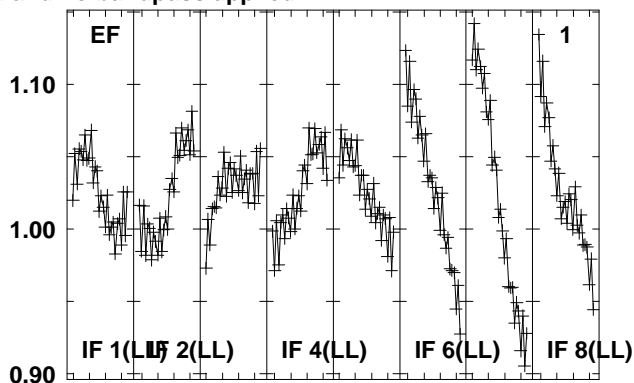
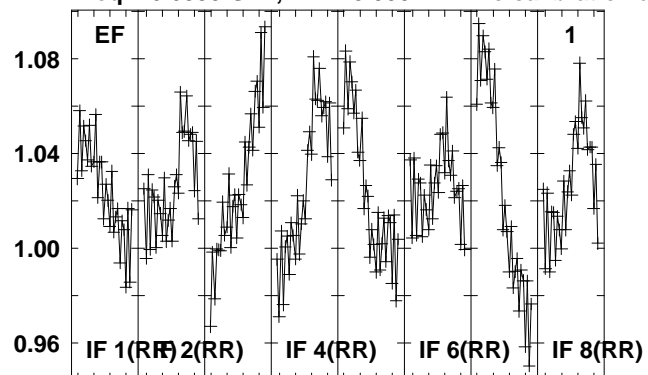

Lower frame: Real Jy
 Total-power spectrum Antenna: *
 Timerange: 00/12:12:21 to 00/12:13:50

Plot file version 90 created 15-MAR-2012 17:31:25

2102-G85 EZ020E 2.UVDATA.1

Freq = 6.6335 GHz, Bw = 8.000 MH No calibration applied and no bandpass applied

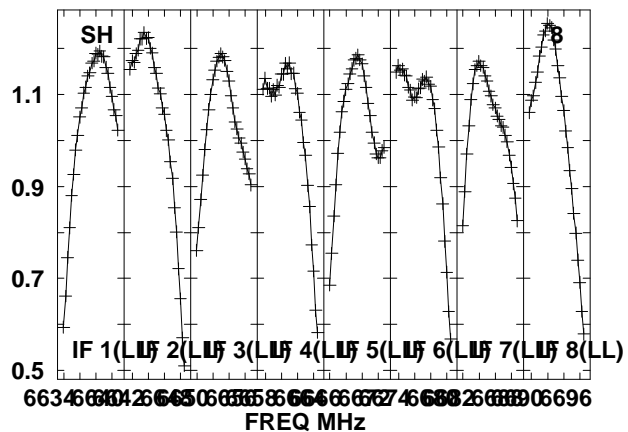
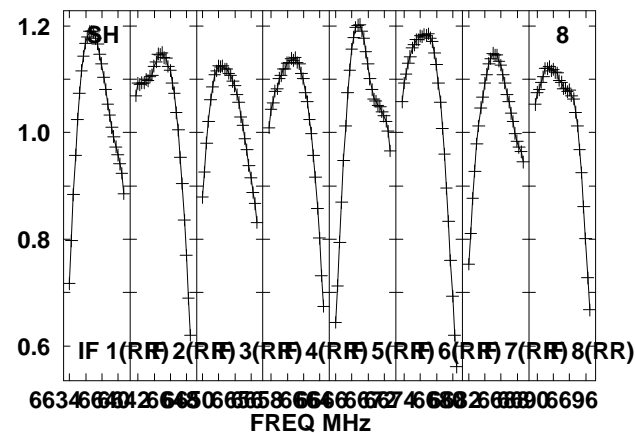
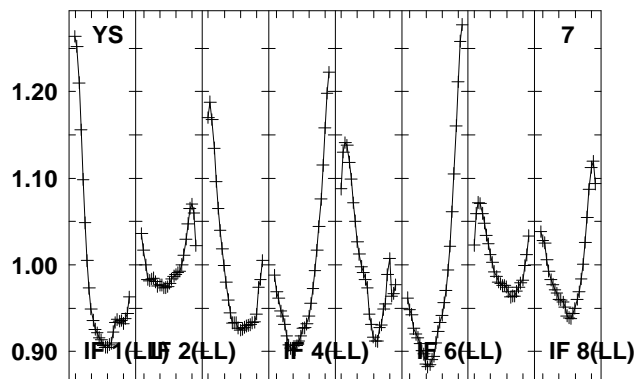
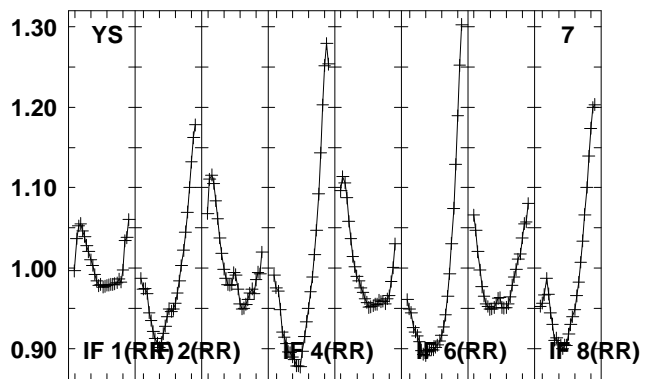
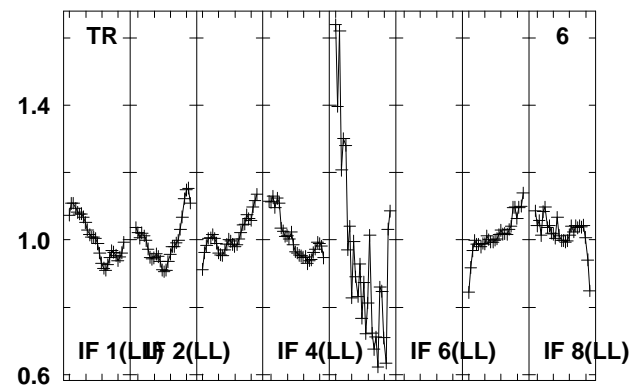
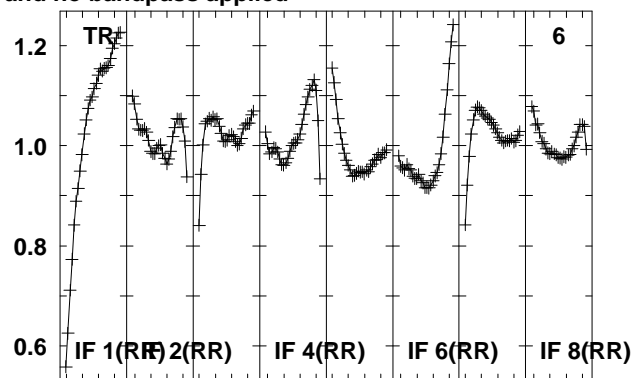
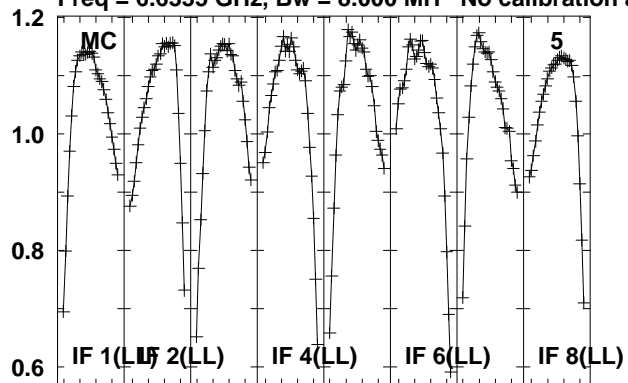

Lower frame: Real Jy

Total-power spectrum Antenna: *

Timerange: 00/12:12:21 to 00/12:13:50

Plot file version 91 created 15-MAR-2012 17:31:26

G85.40 EZ020E 2.UVDATA.1

Freq = 6.6335 GHz, Bw = 8.000 MH No calibration applied and no bandpass applied

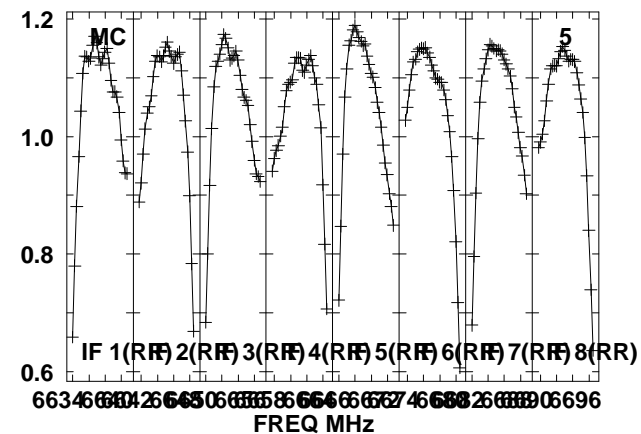
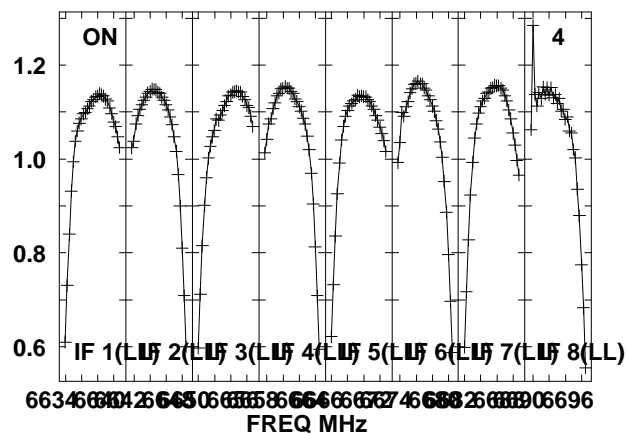
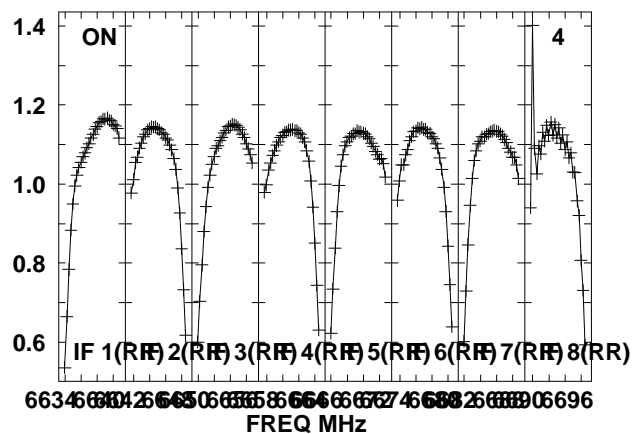
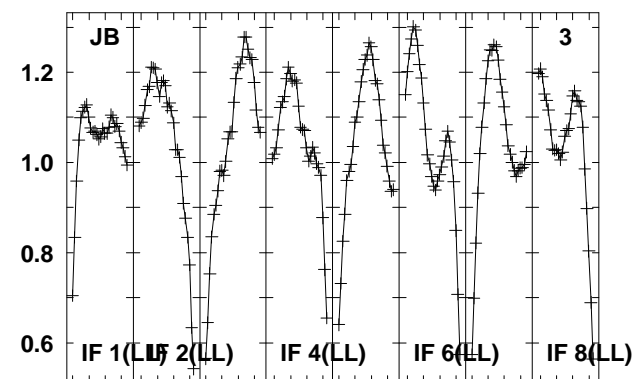
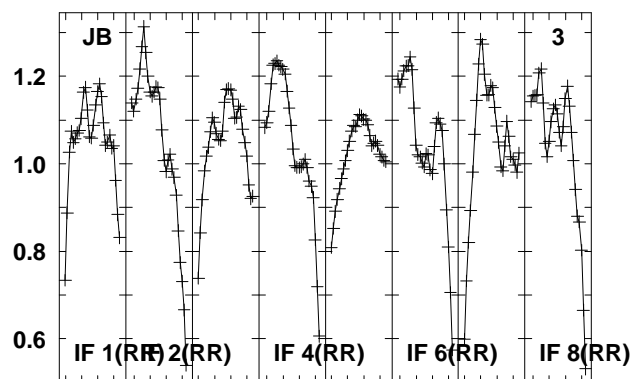
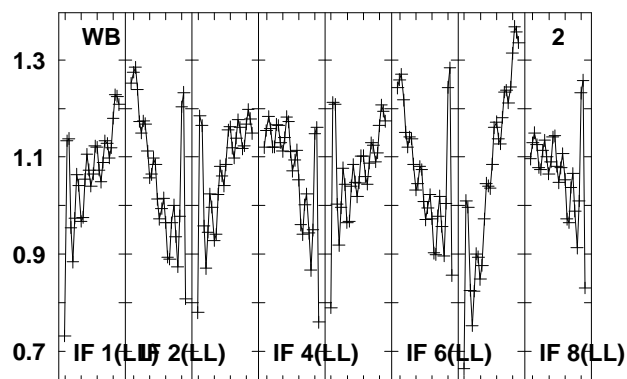
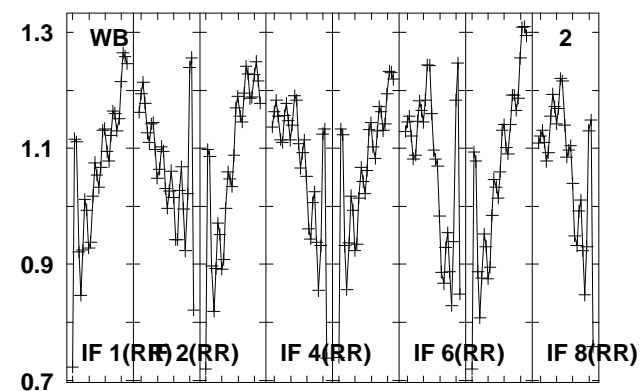
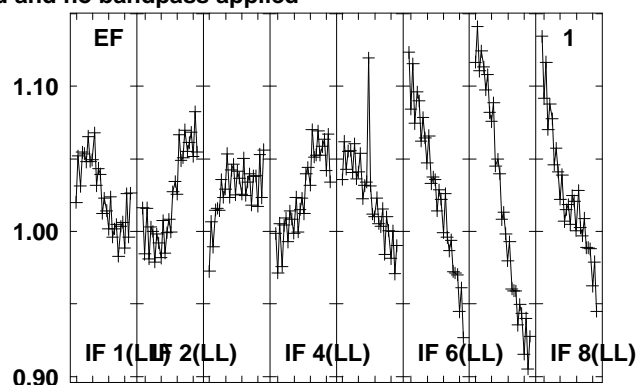
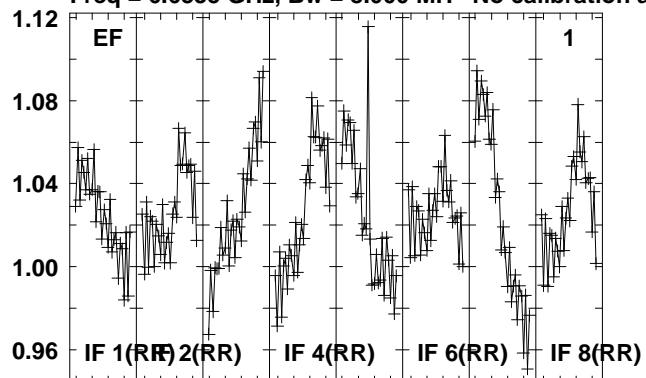

Lower frame: Real Jy
Total-power spectrum Antenna: *
Timerange: 00/12:13:51 to 00/12:15:19

Plot file version 92 created 15-MAR-2012 17:31:27

G85.40 EZ020E 2.UVDATA.1

Freq = 6.6335 GHz, Bw = 8.000 MH No calibration applied and no bandpass applied

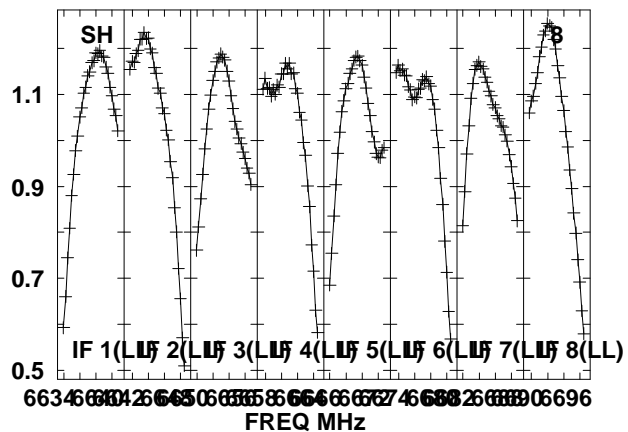
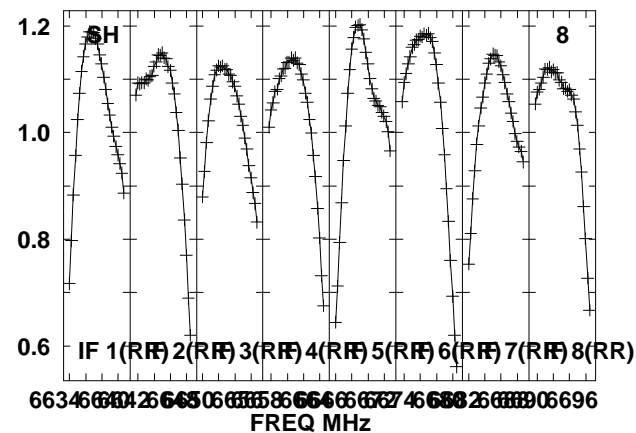
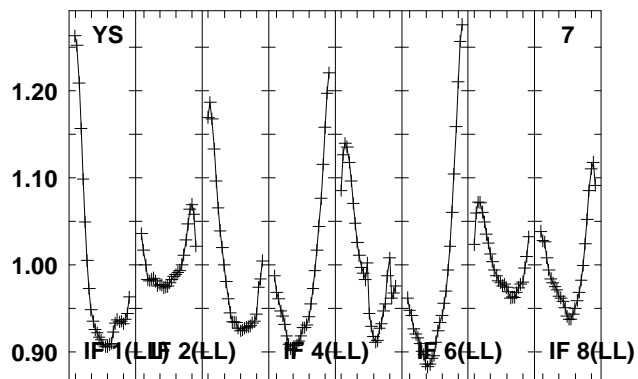
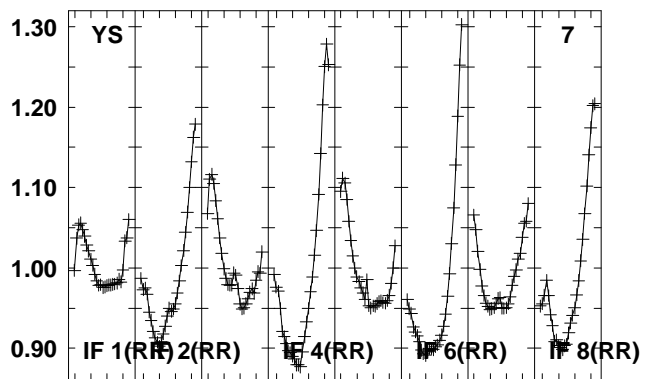
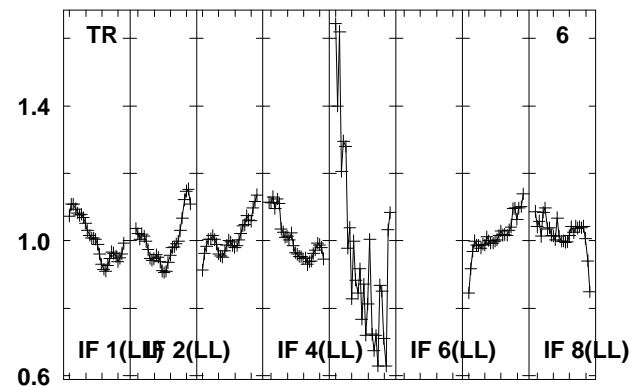
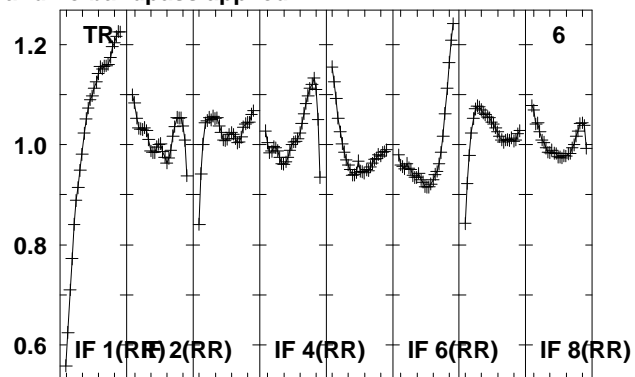
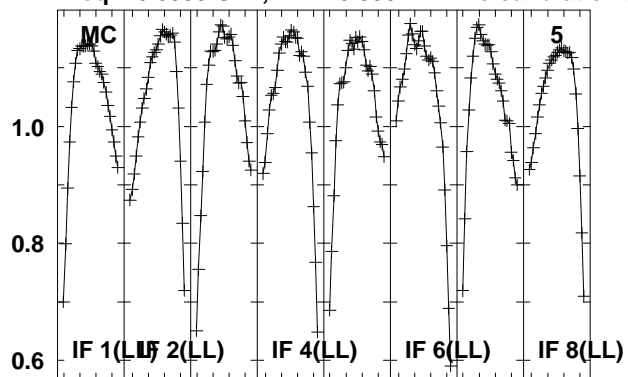

Lower frame: Real Jy

Total-power spectrum Antenna: *

Timerange: 00/12:13:51 to 00/12:15:19

Plot file version 93 created 15-MAR-2012 17:31:27
 2114-G85 EZ020E 2.UVDATA.1
 Freq = 6.6335 GHz, Bw = 8.000 MH No calibration applied and no bandpass applied

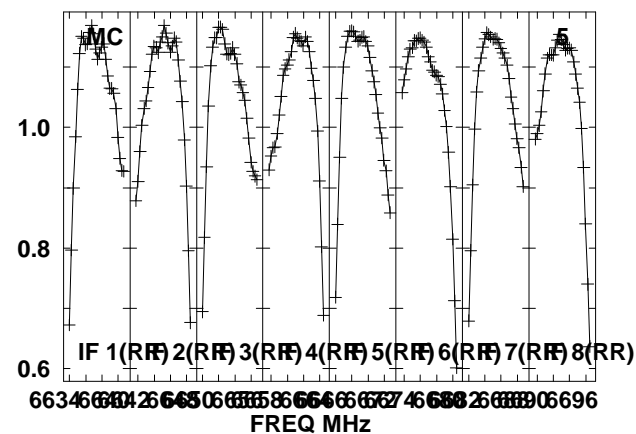
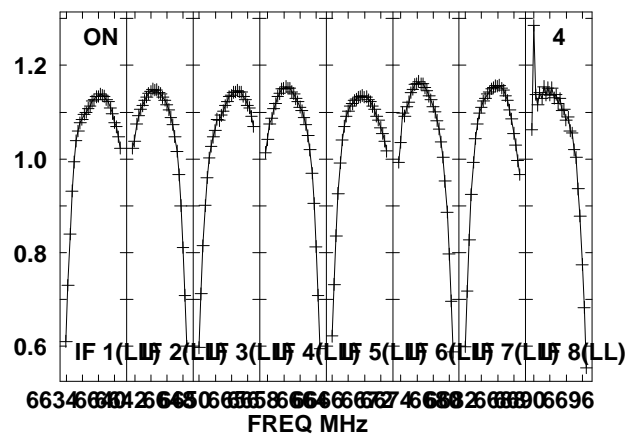
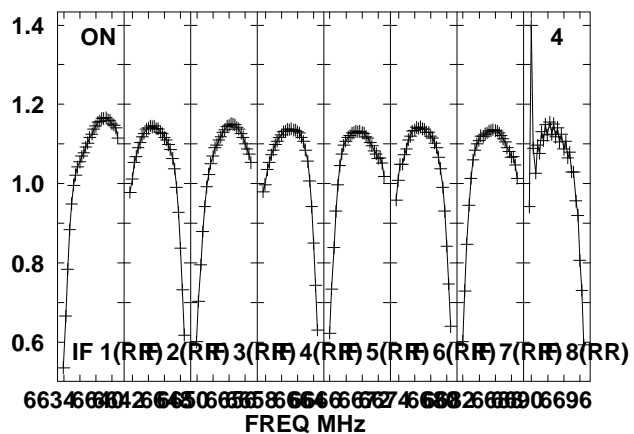
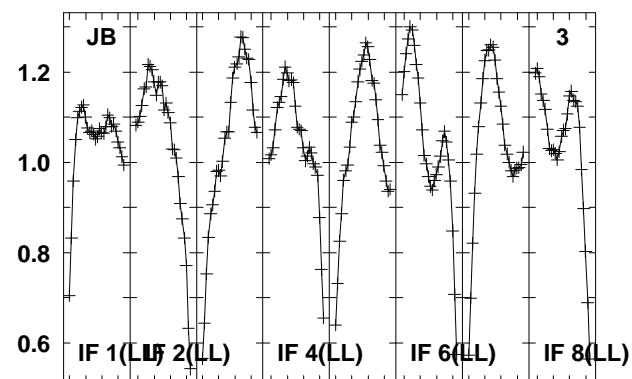
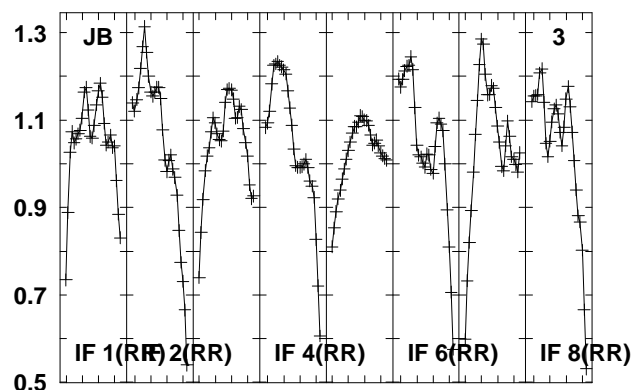
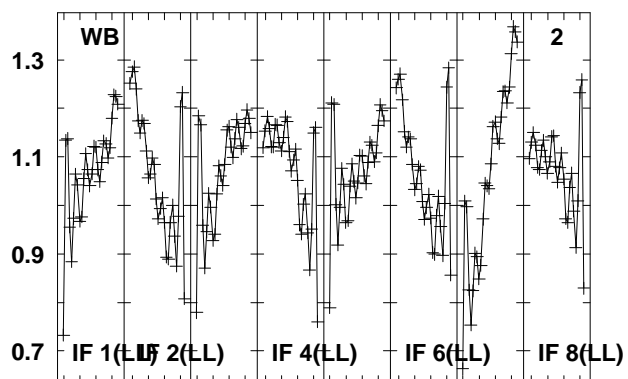
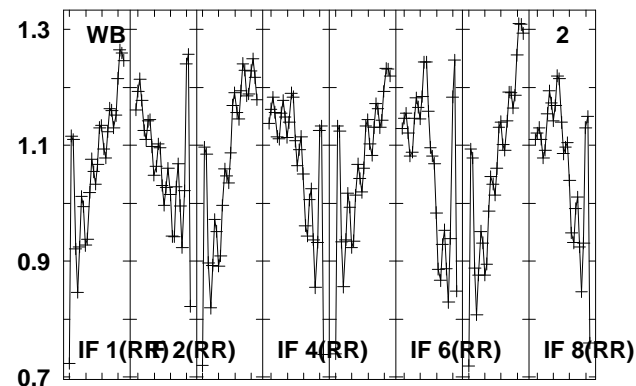
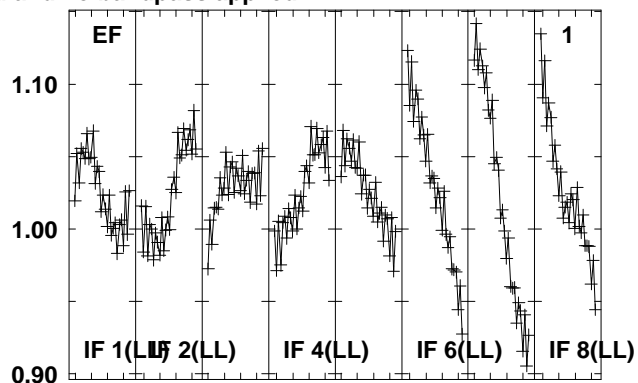
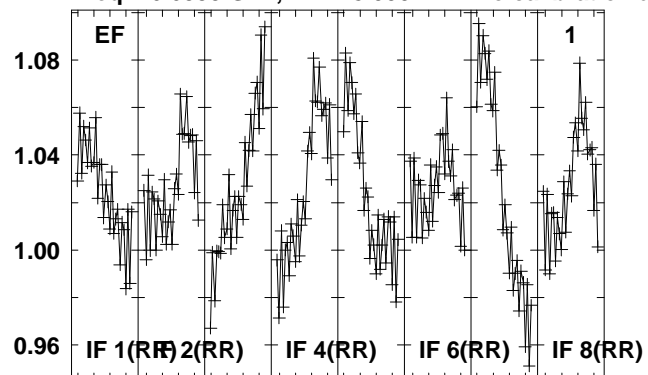

Lower frame: Real Jy
 Total-power spectrum Antenna: *
 Timerange: 00/12:15:22 to 00/12:16:50

Plot file version 94 created 15-MAR-2012 17:31:28

2114-G85 EZ020E 2.UVDATA.1

Freq = 6.6335 GHz, Bw = 8.000 MH No calibration applied and no bandpass applied

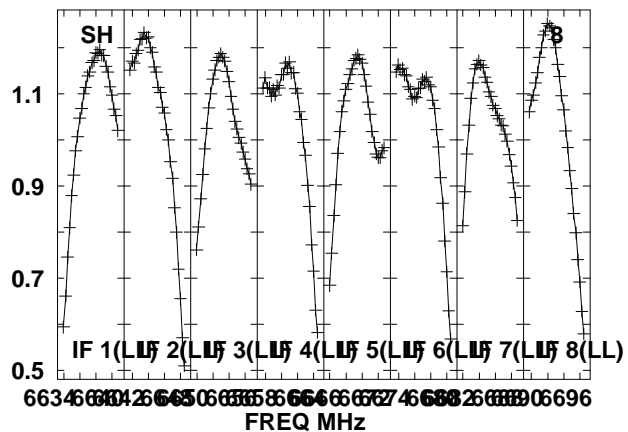
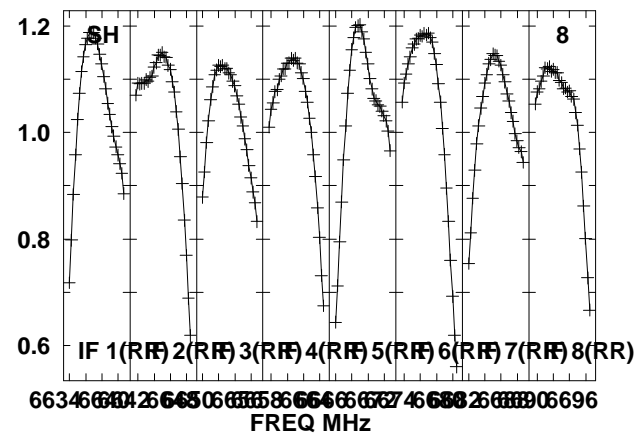
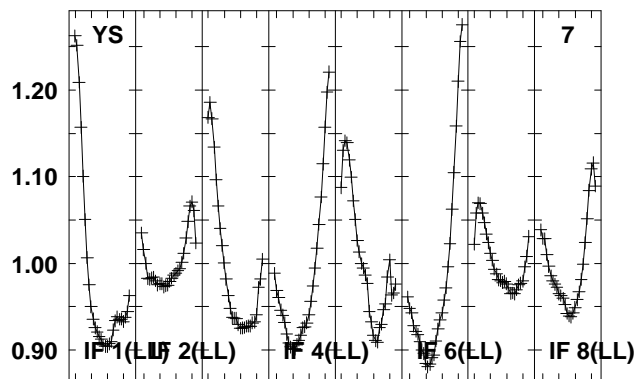
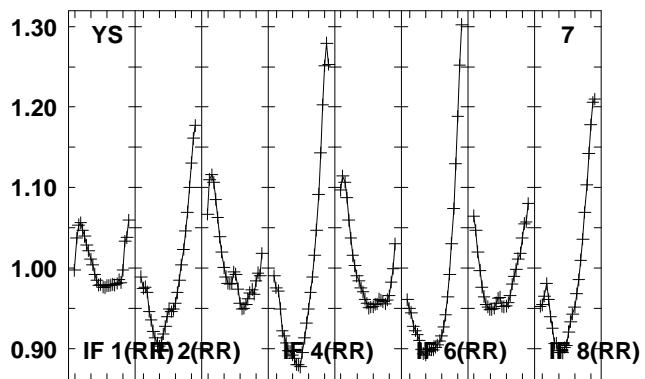
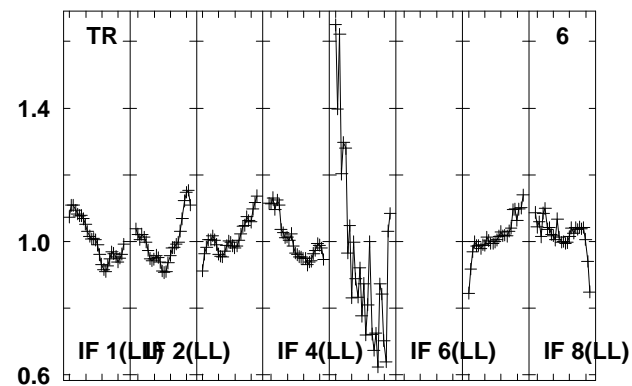
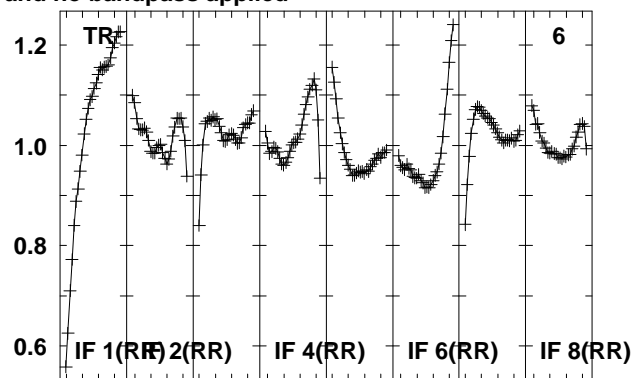
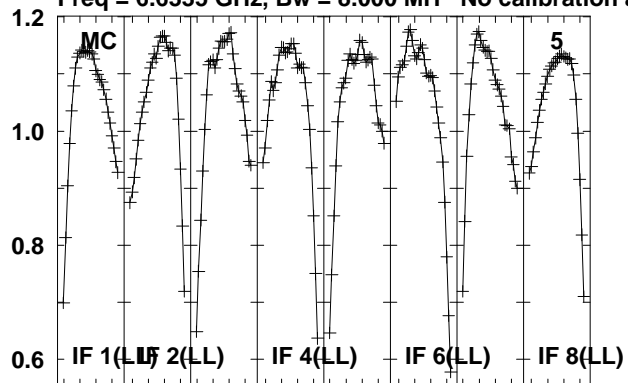

Lower frame: Real Jy
Total-power spectrum Antenna: *
Timerange: 00/12:15:22 to 00/12:16:50

Plot file version 95 created 15-MAR-2012 17:31:29

G85.40 EZ20E 2.UVDATA.1

Freq = 6.6335 GHz, Bw = 8.000 MH No calibration applied and no bandpass applied

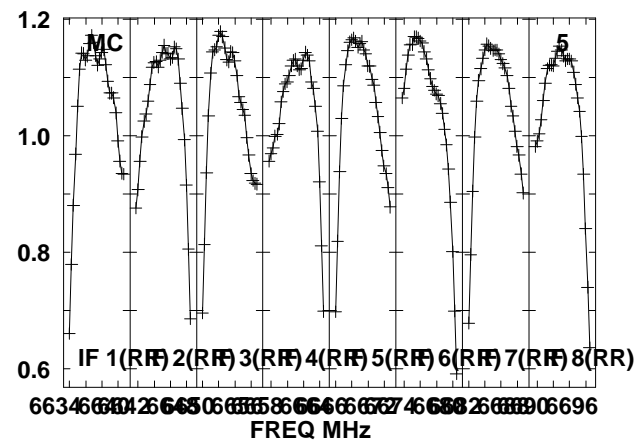
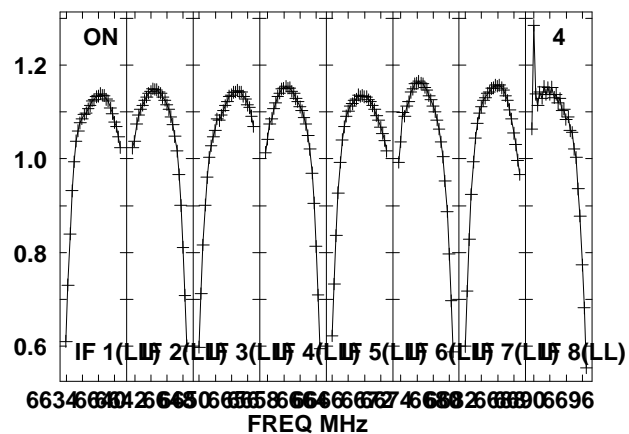
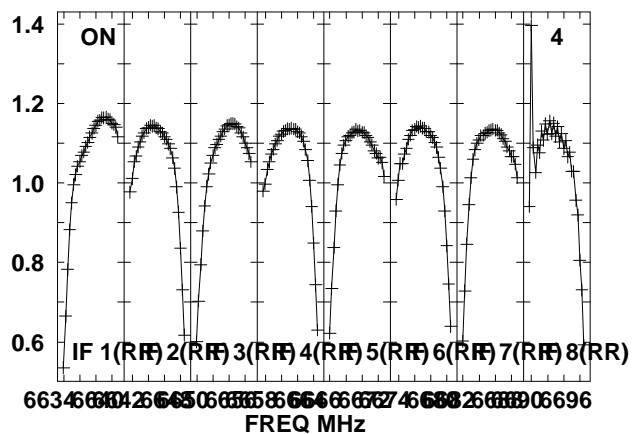
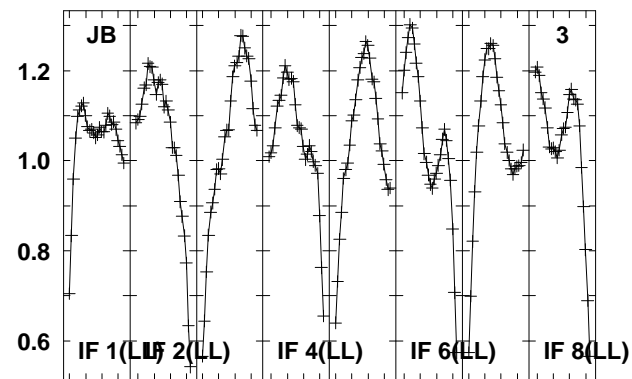
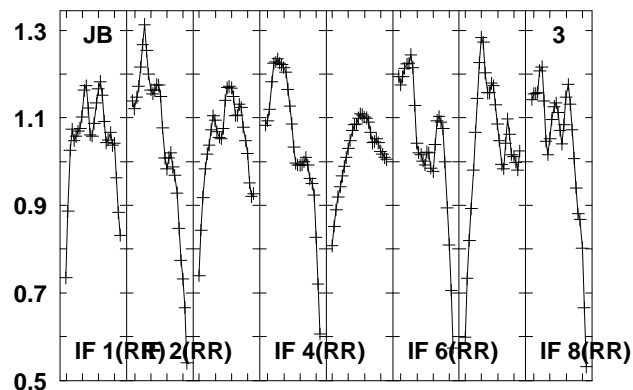
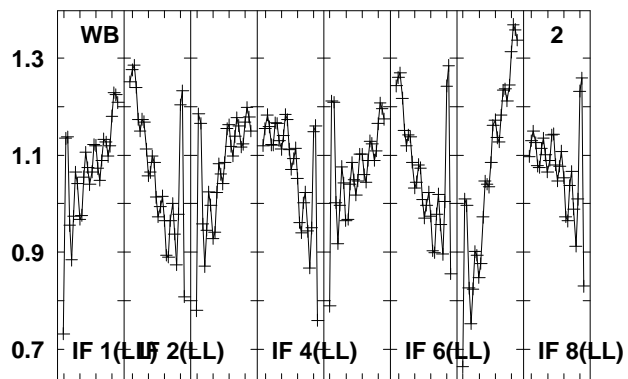
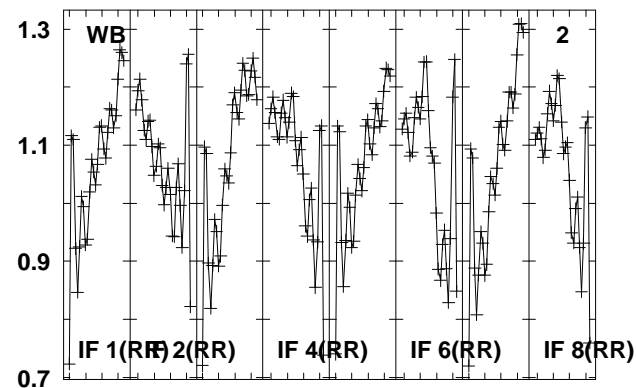
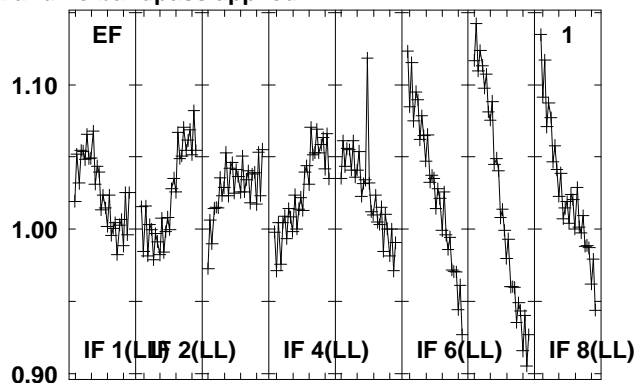
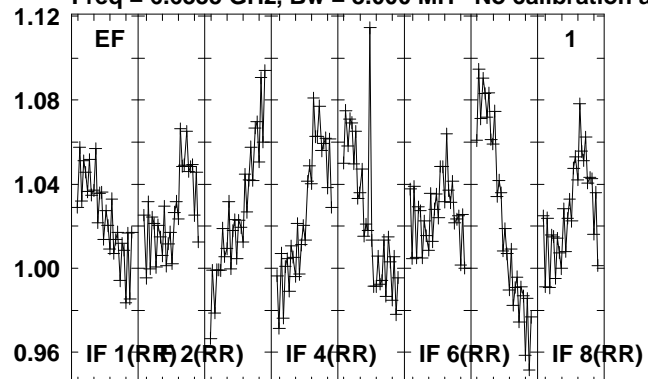

Lower frame: Real Jy
Total-power spectrum Antenna: *
Timerange: 00/12:16:52 to 00/12:18:20

Plot file version 96 created 15-MAR-2012 17:31:29

G85.40 EZ020E 2.UVDATA.1

Freq = 6.6335 GHz, Bw = 8.000 MH No calibration applied and no bandpass applied

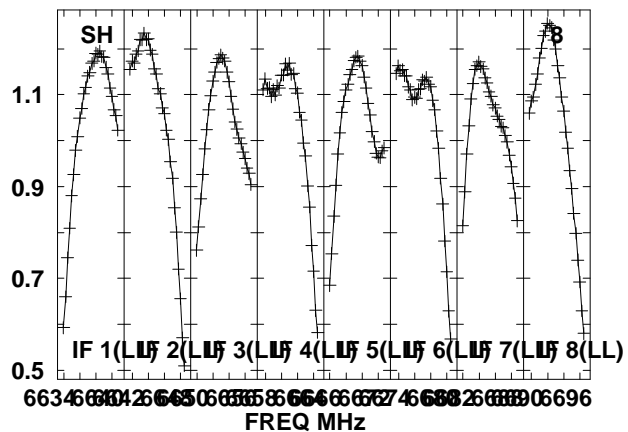
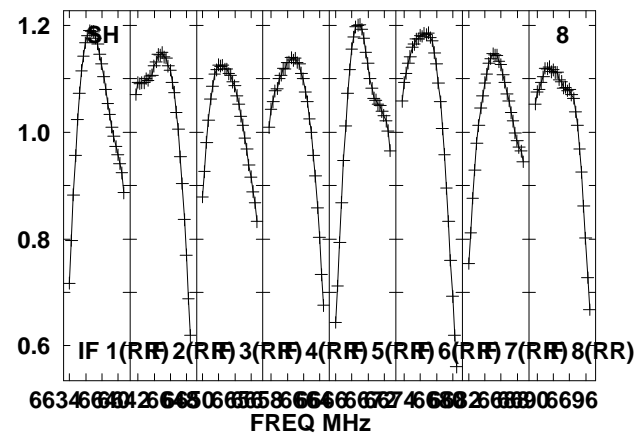
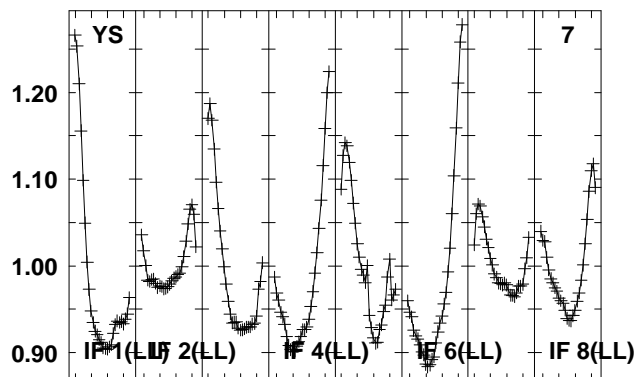
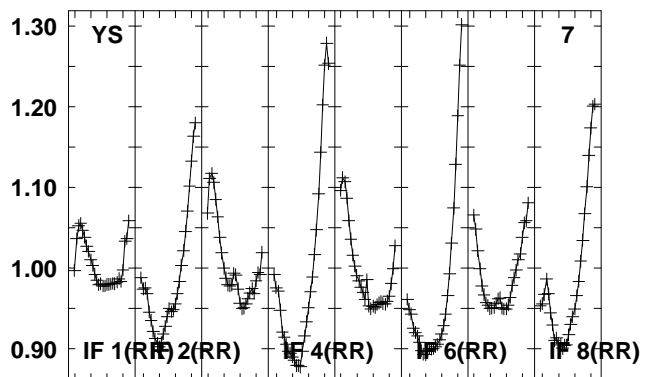
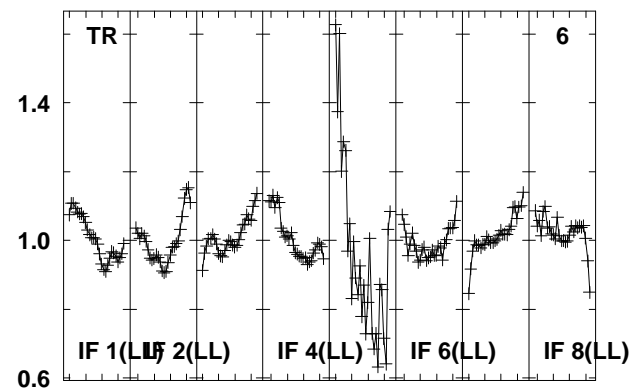
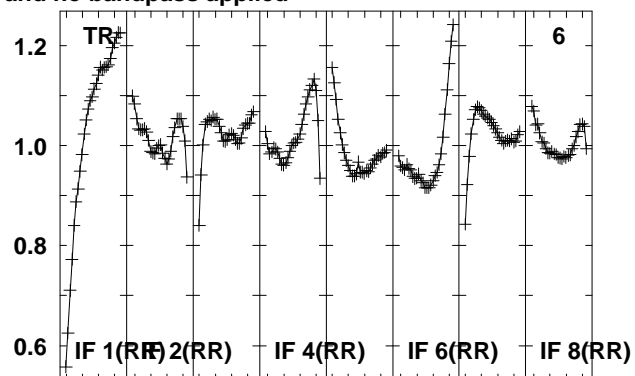
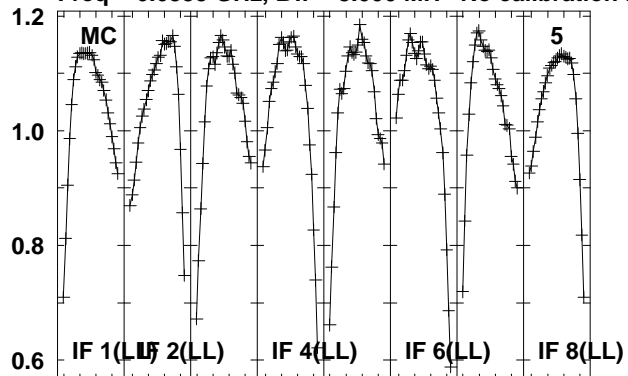

Lower frame: Real Jy

Total-power spectrum Antenna: *

Timerange: 00/12:16:52 to 00/12:18:20

Plot file version 97 created 15-MAR-2012 17:31:30
 2102-G85 EZ020E 2.UVDATA.1
 Freq = 6.6335 GHz, Bw = 8.000 MH No calibration applied and no bandpass applied

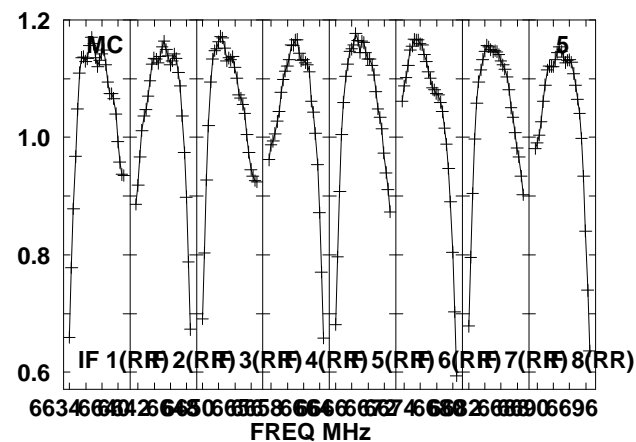
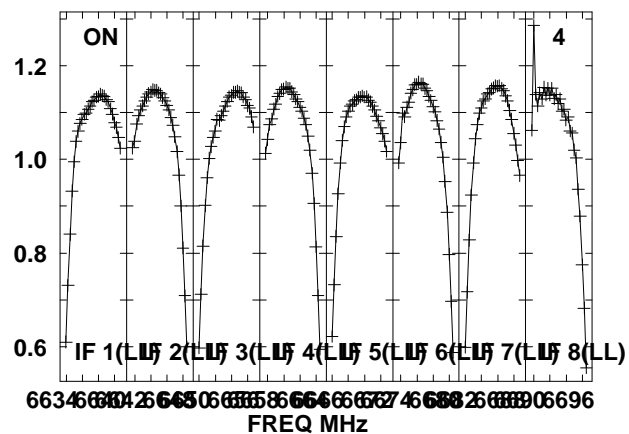
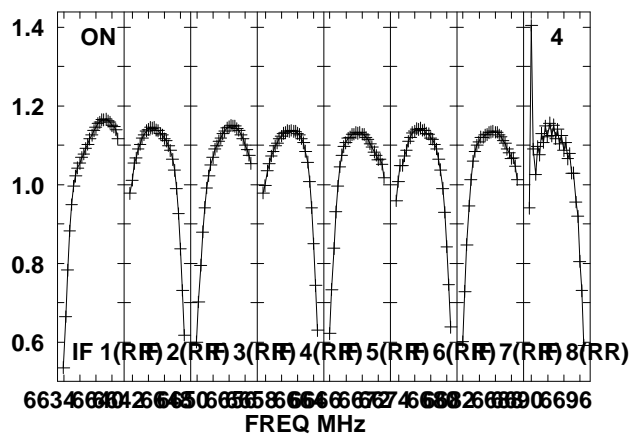
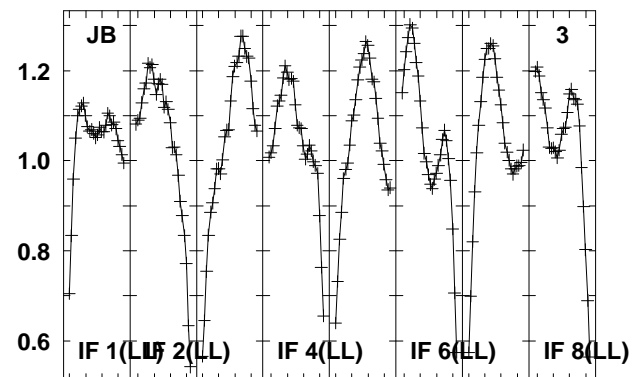
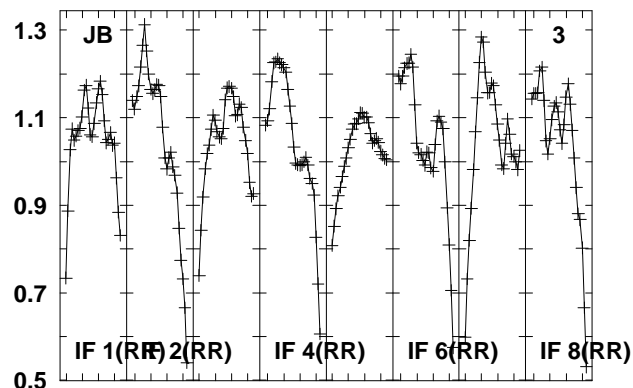
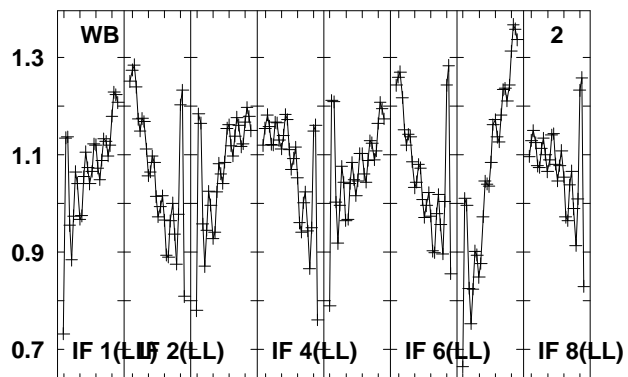
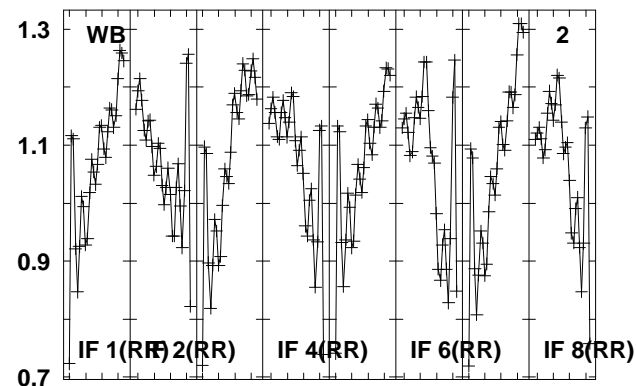
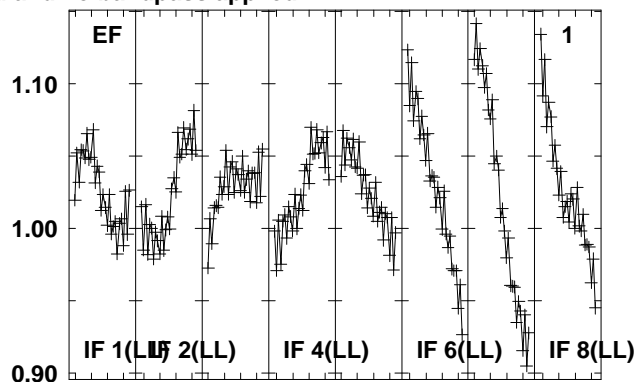
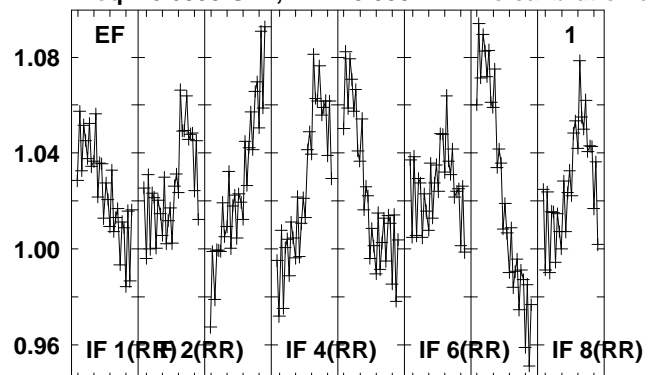

Lower frame: Real Jy
 Total-power spectrum Antenna: *
 Timerange: 00/12:18:21 to 00/12:19:50

Plot file version 98 created 15-MAR-2012 17:31:31

2102-G85 EZ020E 2.UVDATA.1

Freq = 6.6335 GHz, Bw = 8.000 MH No calibration applied and no bandpass applied

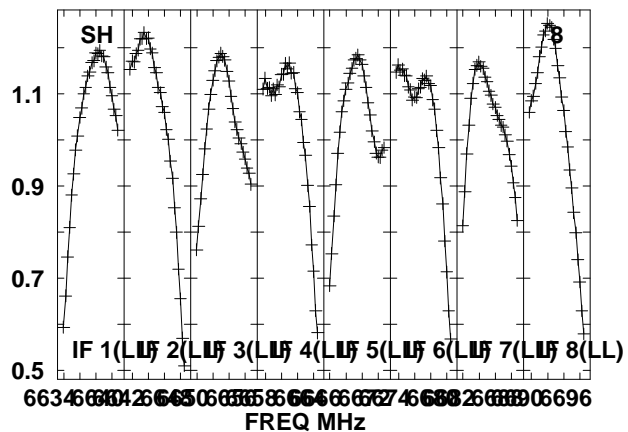
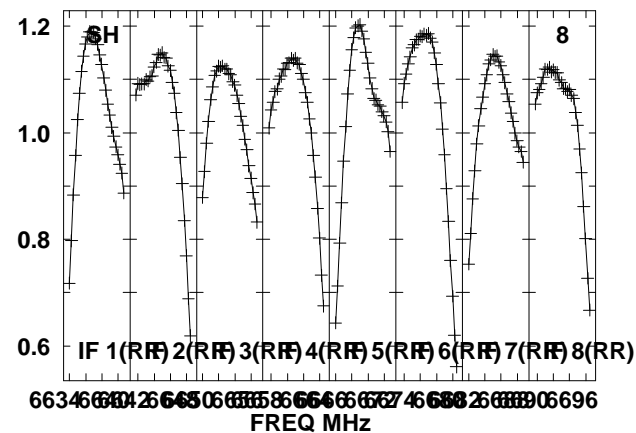
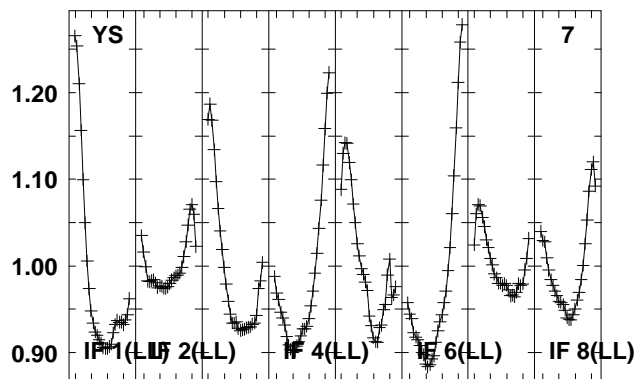
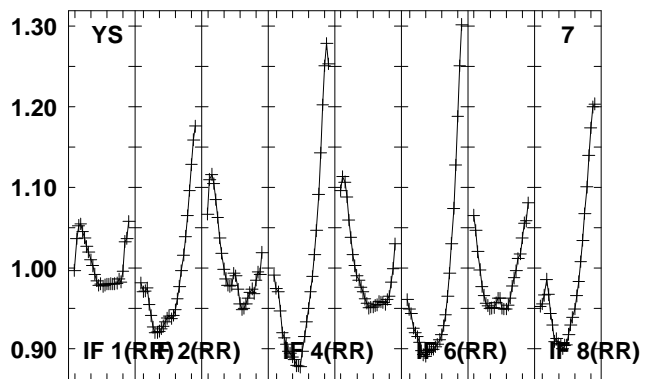
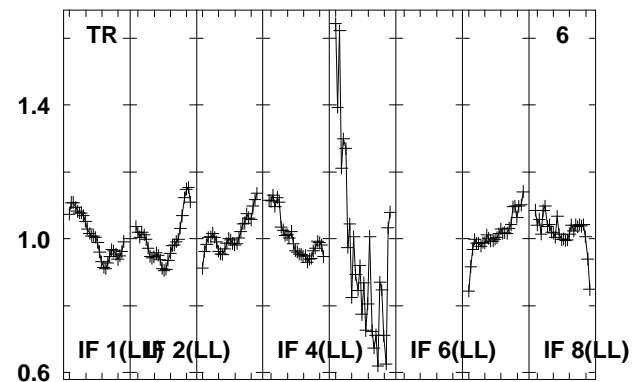
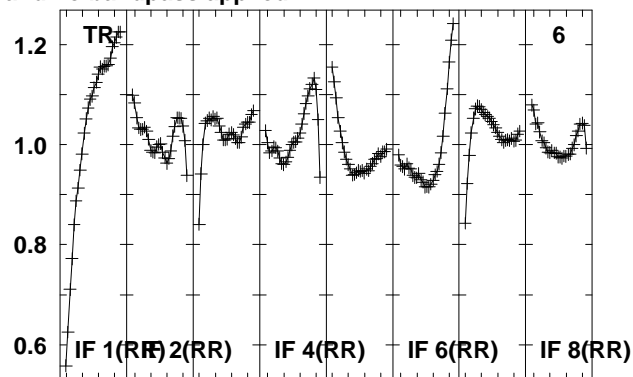
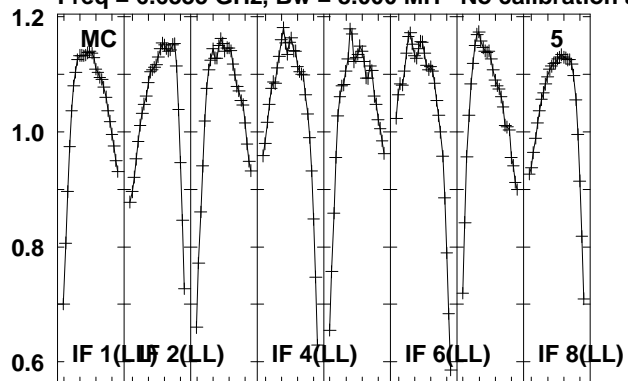

Lower frame: Real Jy

Total-power spectrum Antenna: *

Timerange: 00/12:18:21 to 00/12:19:50

Plot file version 99 created 15-MAR-2012 17:31:32

G85.40 EZ020E 2.UVDATA.1

Freq = 6.6335 GHz, Bw = 8.000 MH No calibration applied and no bandpass applied

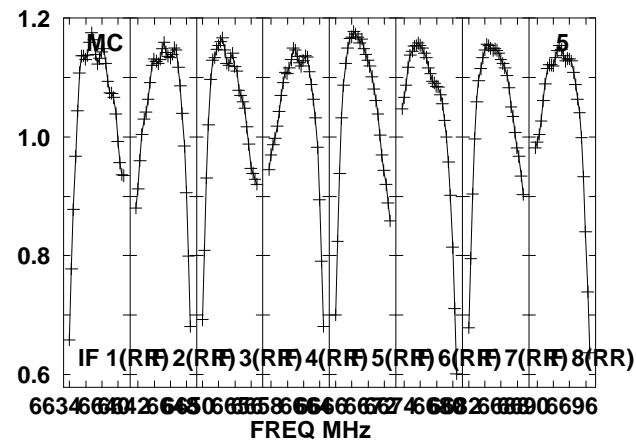
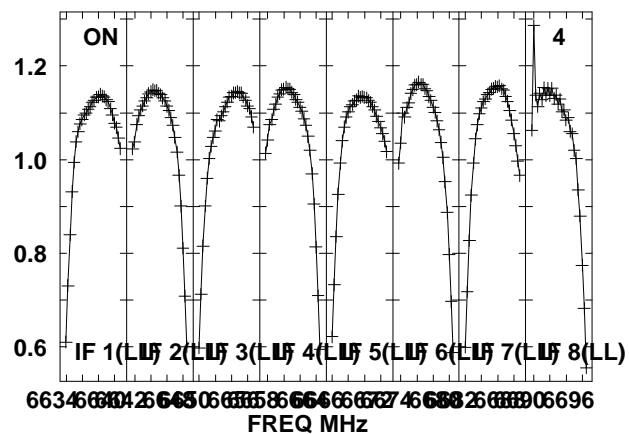
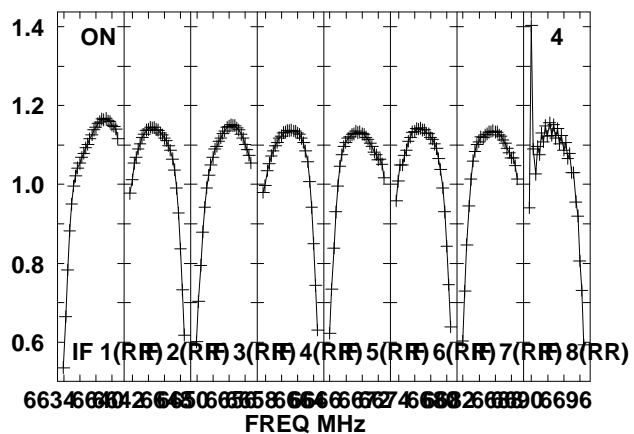
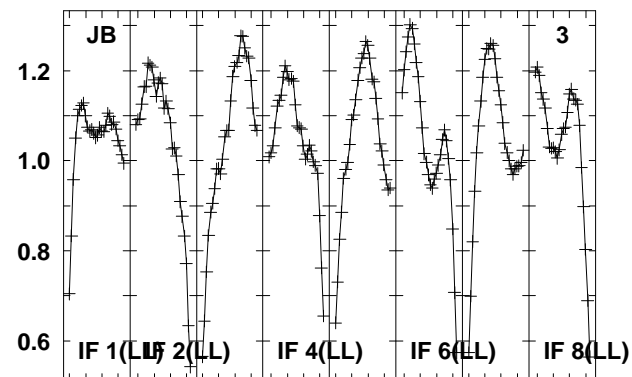
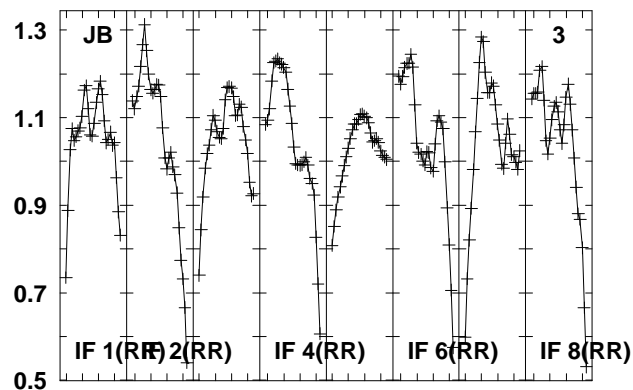
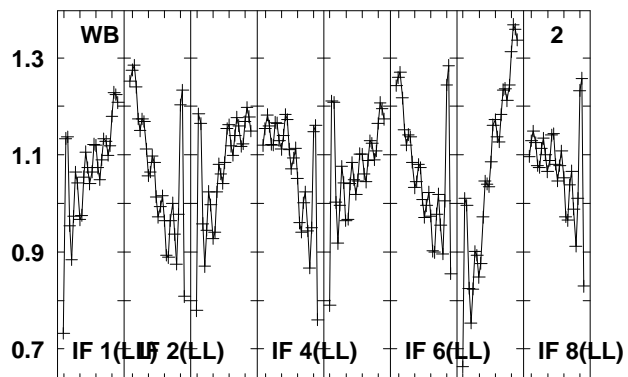
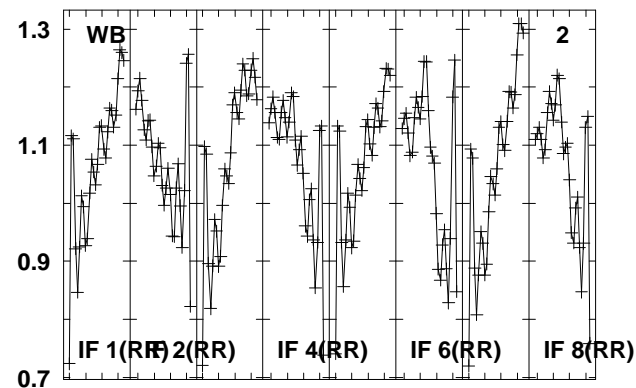
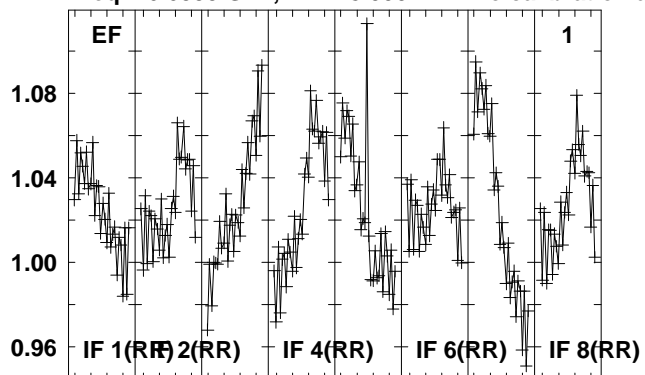

Lower frame: Real Jy
Total-power spectrum Antenna: *
Timerange: 00/12:19:51 to 00/12:21:19

Plot file version 100 created 15-MAR-2012 17:31:32

G85.40 EZ020E 2.UVDATA.1

Freq = 6.6335 GHz, Bw = 8.000 MH No calibration applied and no bandpass applied

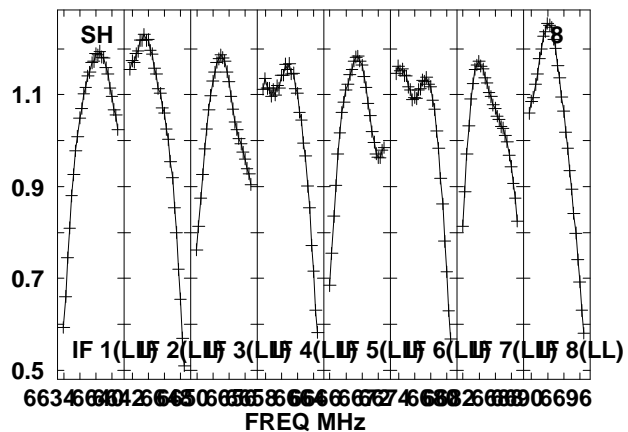
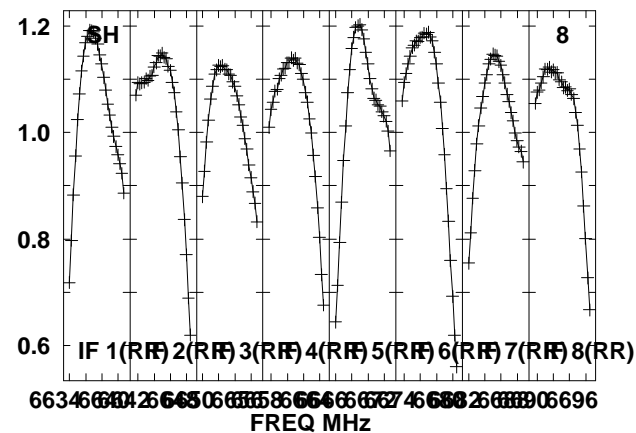
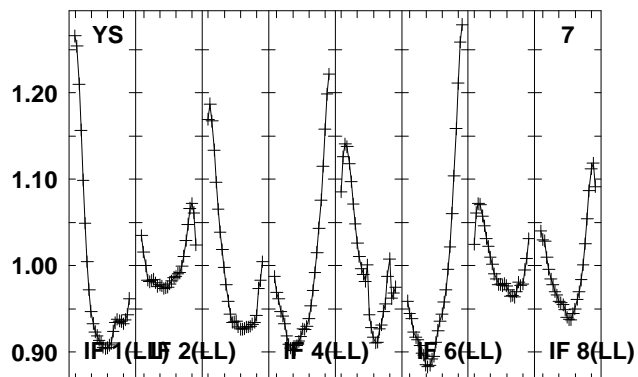
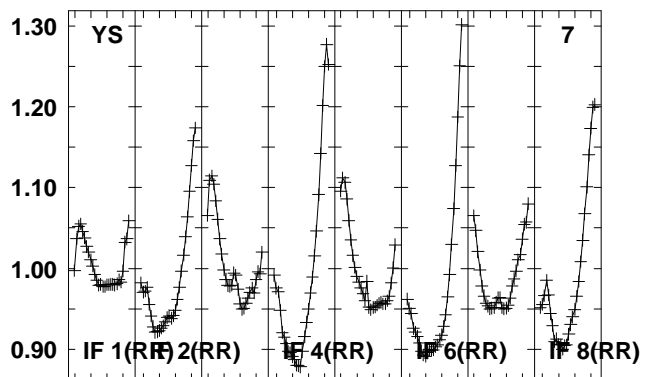
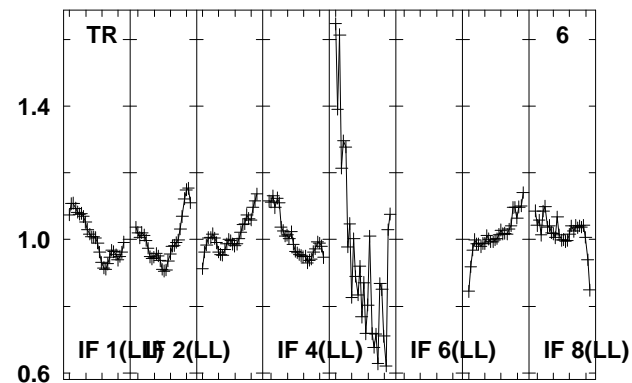
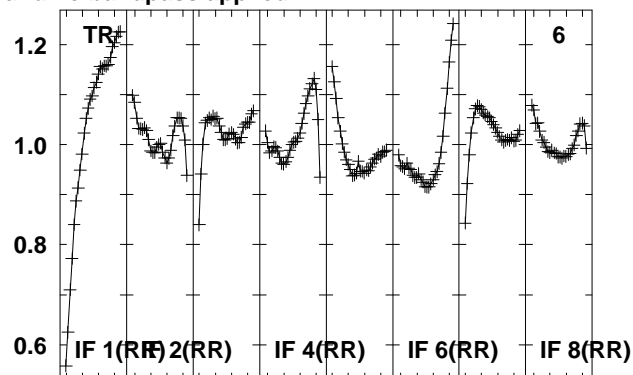
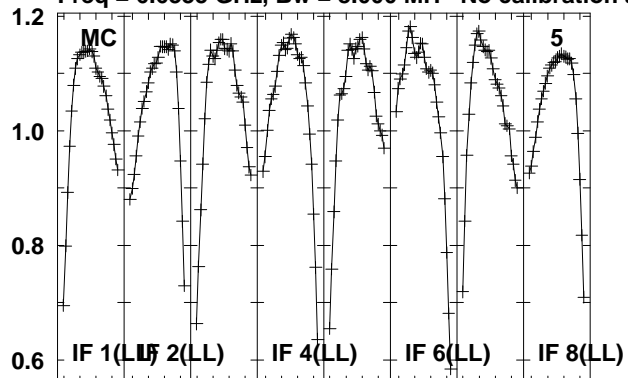

Lower frame: Real Jy

Total-power spectrum Antenna: *

Timerange: 00/12:19:51 to 00/12:21:19

Plot file version 101 created 15-MAR-2012 17:31:33

2114-G85 EZ020E 2.UVDATA.1

Freq = 6.6335 GHz, Bw = 8.000 MH No calibration applied and no bandpass applied

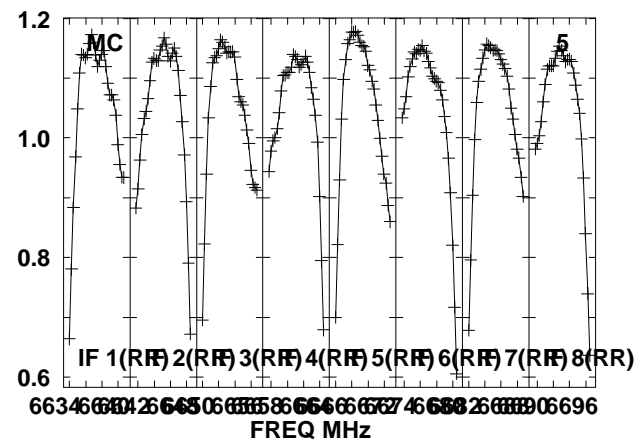
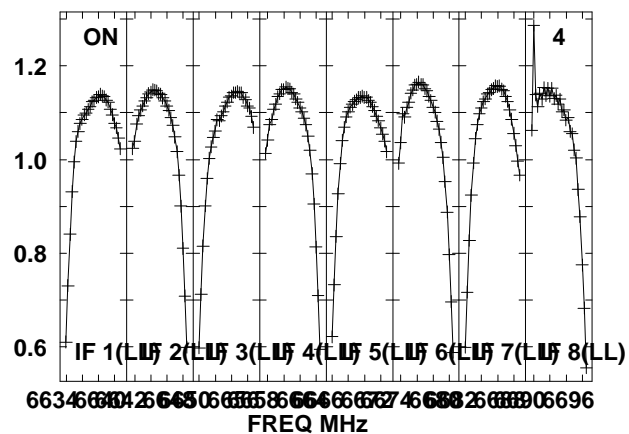
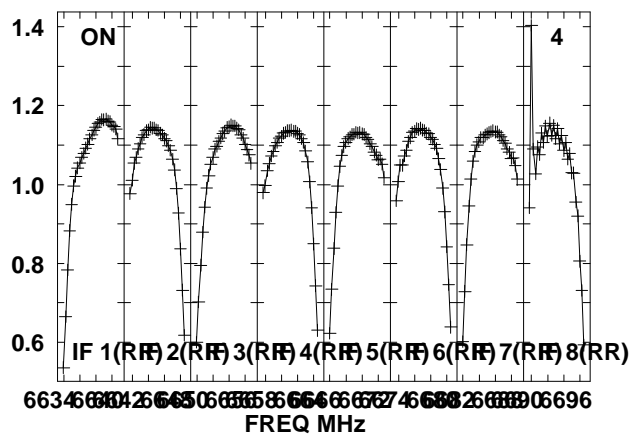
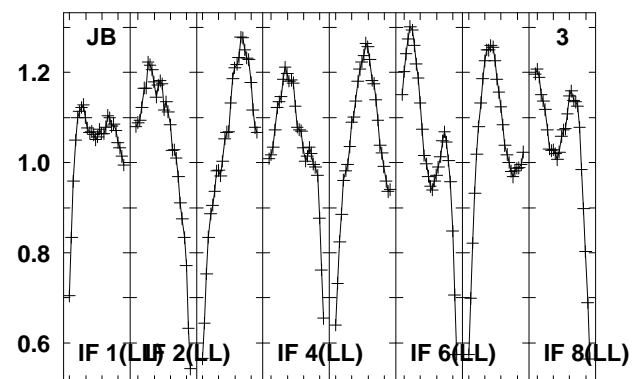
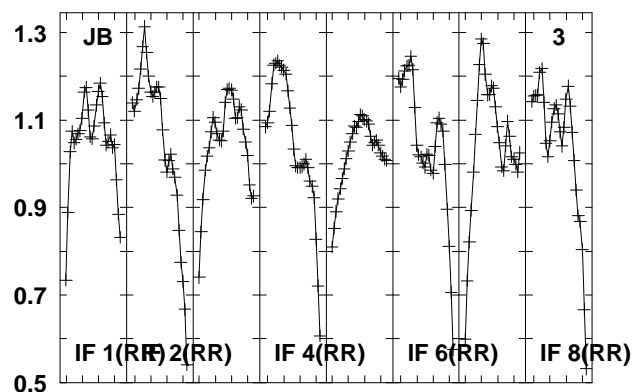
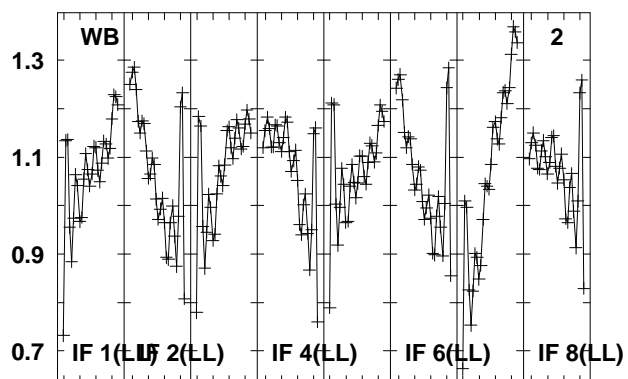
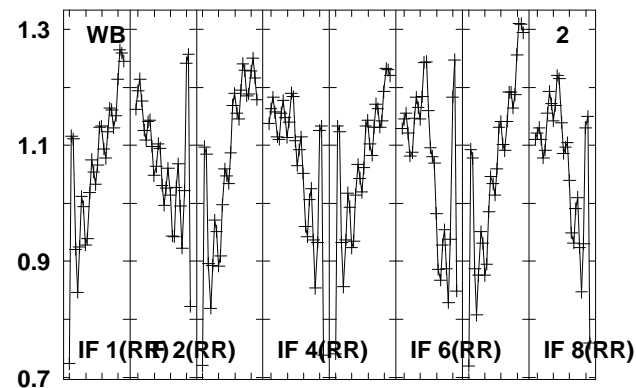
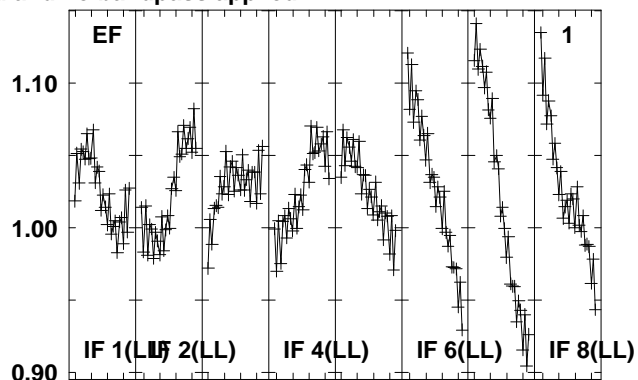
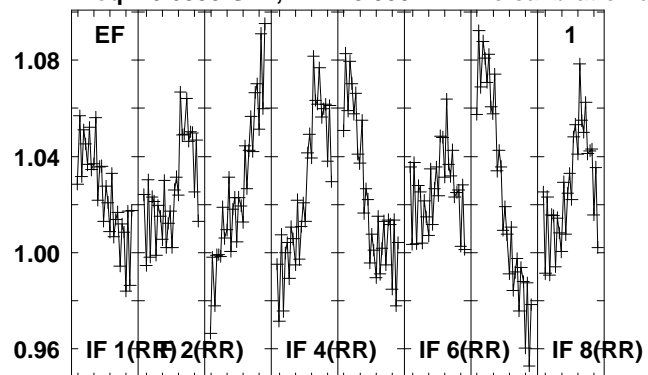

Lower frame: Real Jy

Total-power spectrum Antenna: *

Timerange: 00/12:21:22 to 00/12:22:50

Plot file version 102 created 15-MAR-2012 17:31:34

2114-G85 EZ020E 2.UVDATA.1

Freq = 6.6335 GHz, Bw = 8.000 MH No calibration applied and no bandpass applied

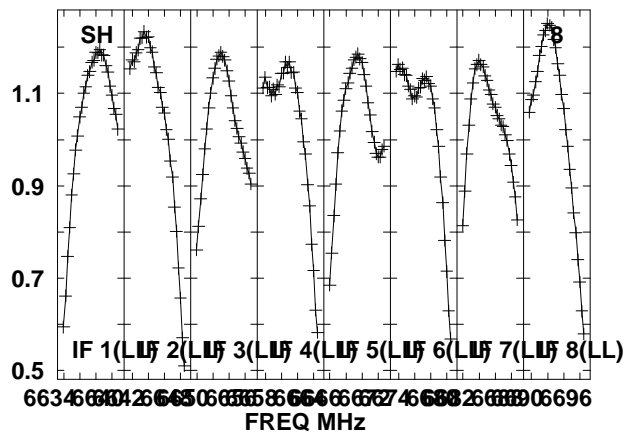
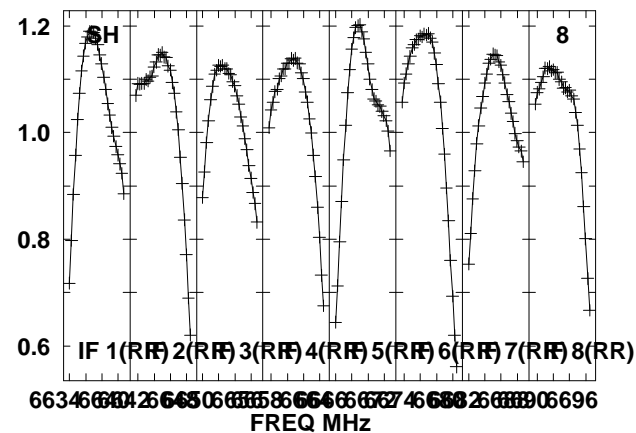
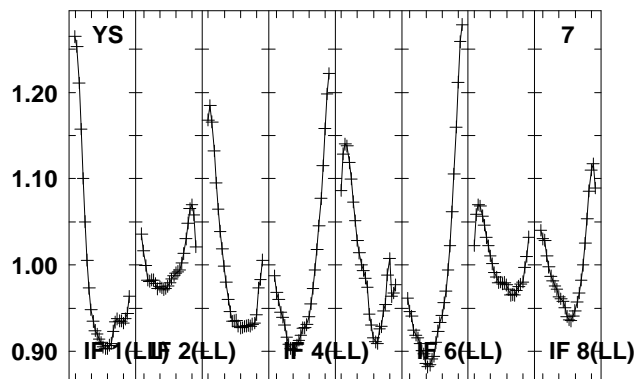
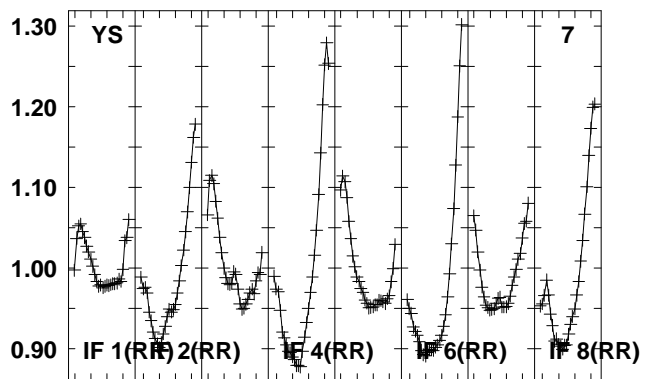
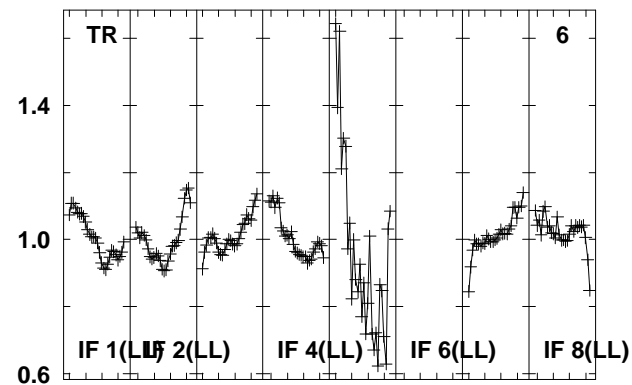
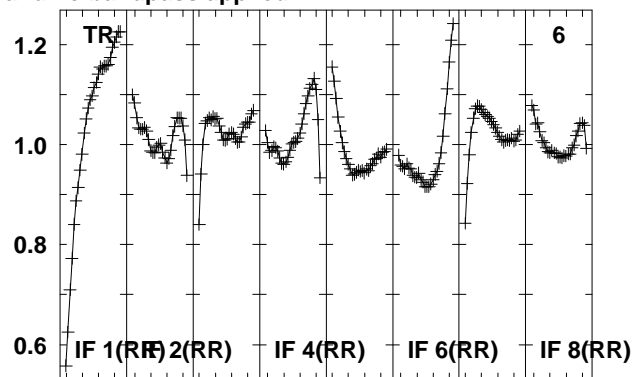
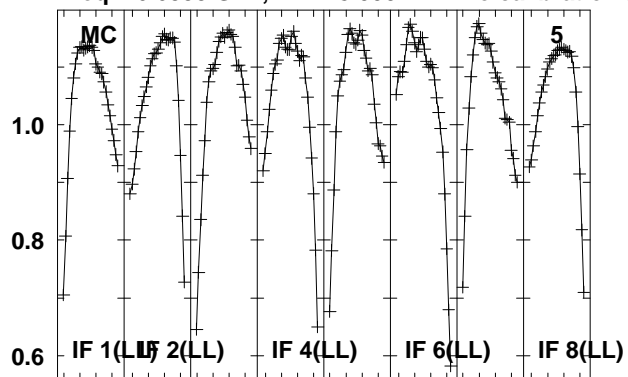

Lower frame: Real Jy

Total-power spectrum Antenna: *

Timerange: 00/12:21:22 to 00/12:22:50

Plot file version 103 created 15-MAR-2012 17:31:35

G85.40 EZ020E 2.UVDATA.1

Freq = 6.6335 GHz, Bw = 8.000 MH No calibration applied and no bandpass applied

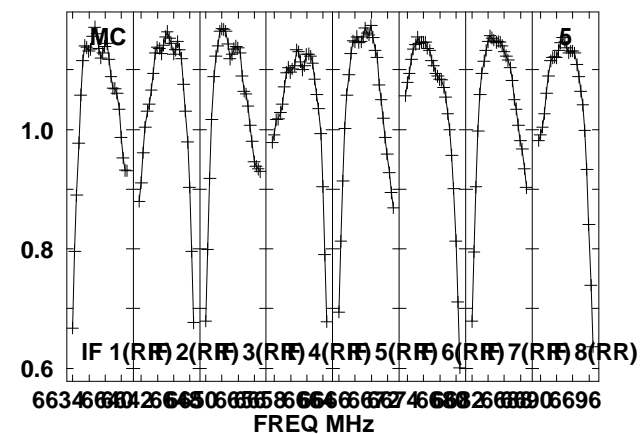
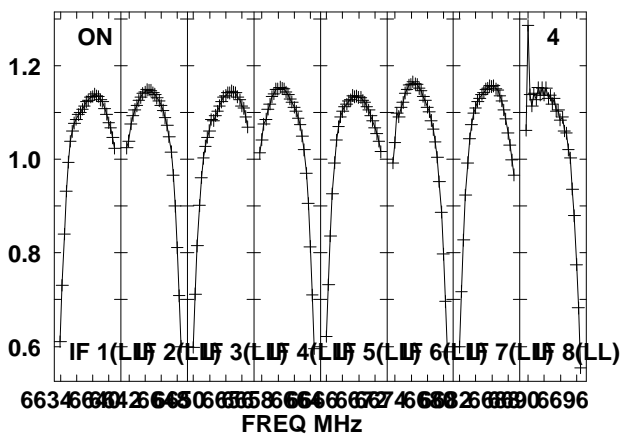
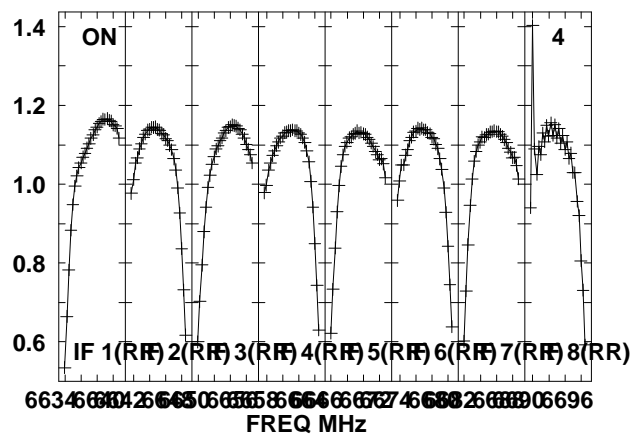
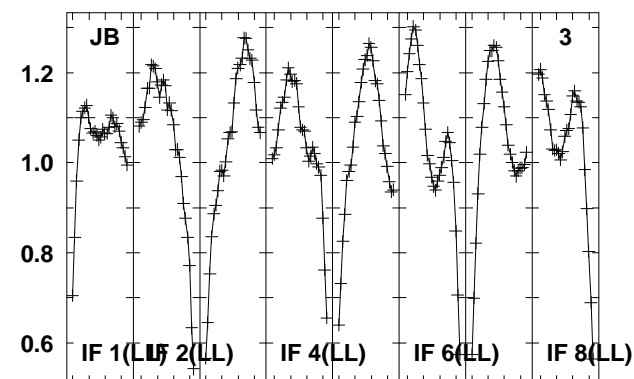
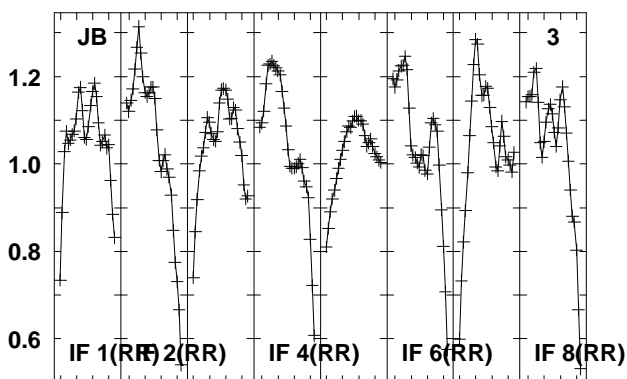
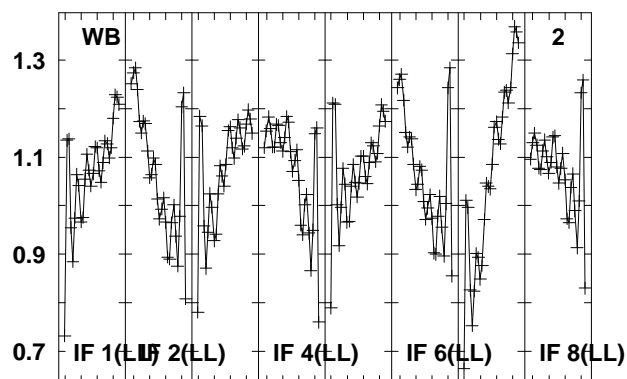
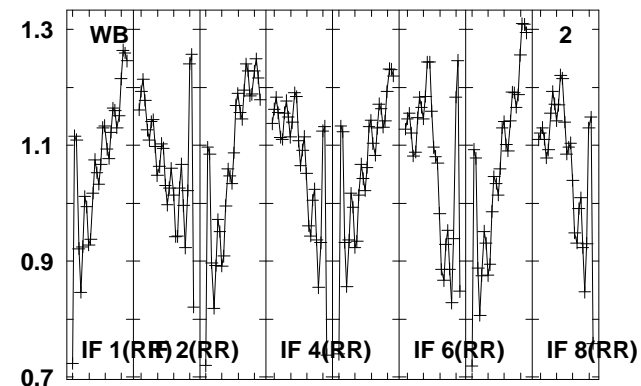
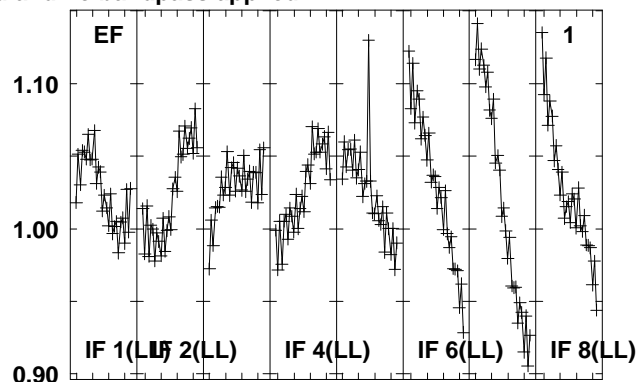
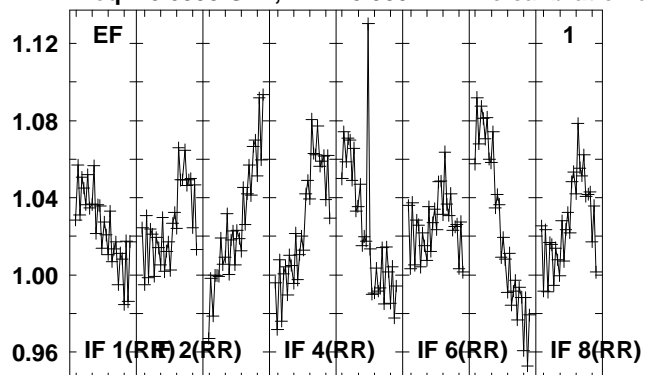

Lower frame: Real Jy
Total-power spectrum Antenna: *
Timerange: 00:12:22:52 to 00:12:24:20

Plot file version 104 created 15-MAR-2012 17:31:36

G85.40 EZ020E 2.UVDATA.1

Freq = 6.6335 GHz, Bw = 8.000 MH No calibration applied and no bandpass applied

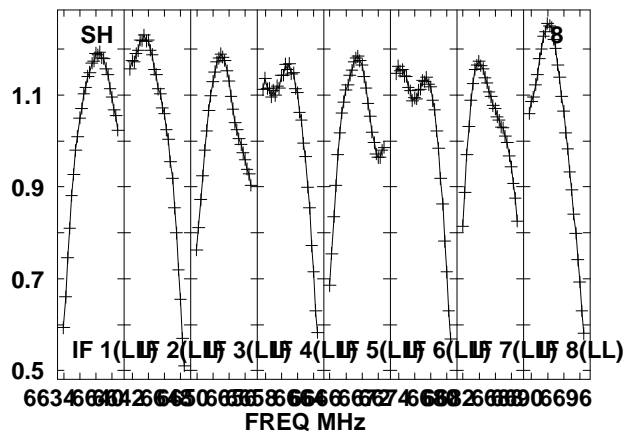
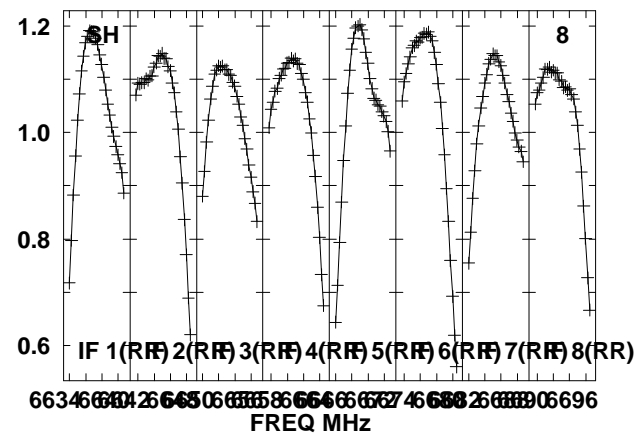
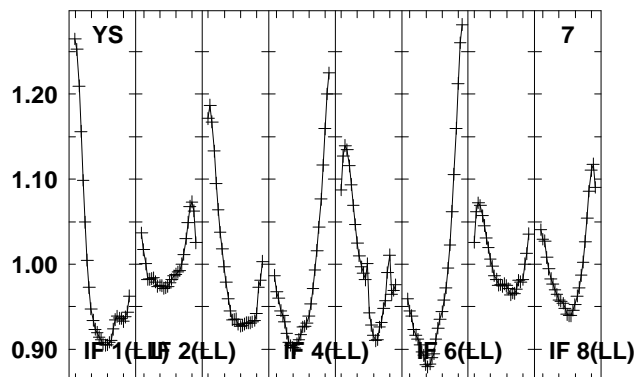
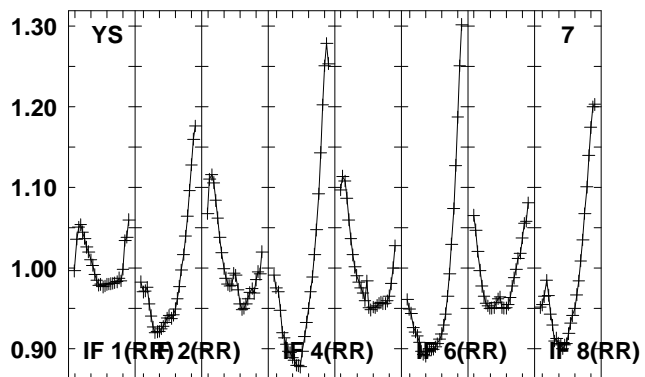
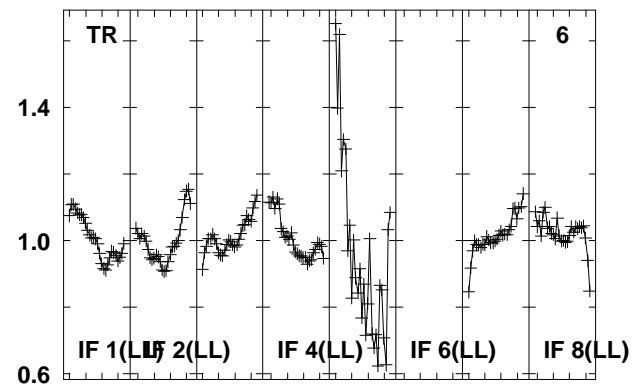
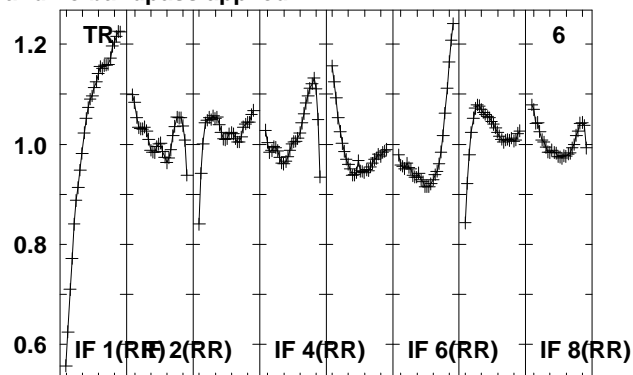
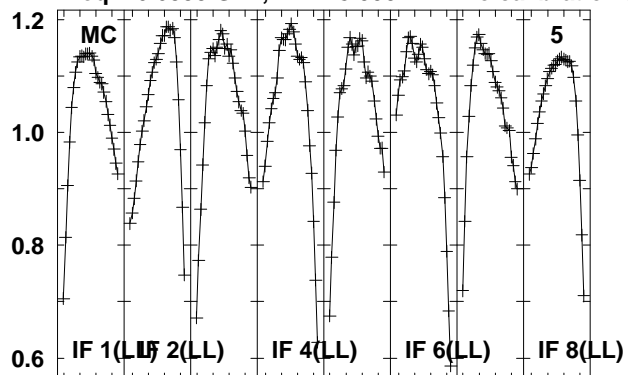

Lower frame: Real Jy

Total-power spectrum Antenna: *

Timerange: 00/12:22:52 to 00/12:24:20

Plot file version 105 created 15-MAR-2012 17:31:37
 2102-G85 EZ020E 2.UVDATA.1
 Freq = 6.6335 GHz, Bw = 8.000 MH No calibration applied and no bandpass applied

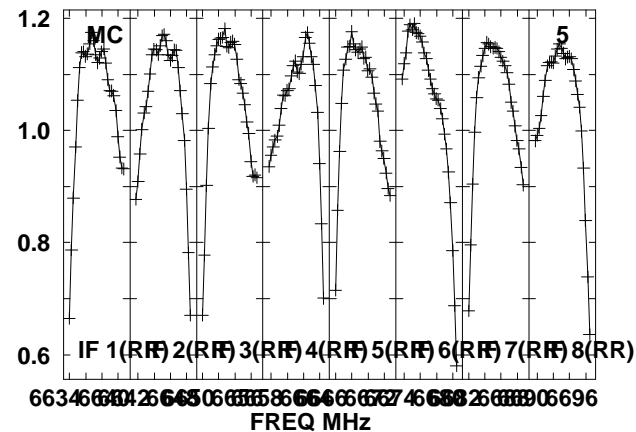
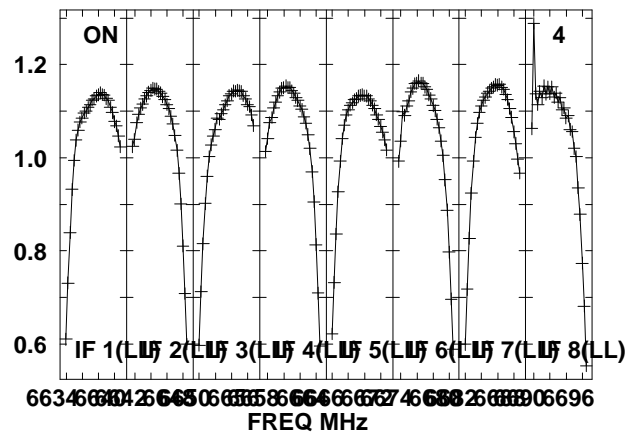
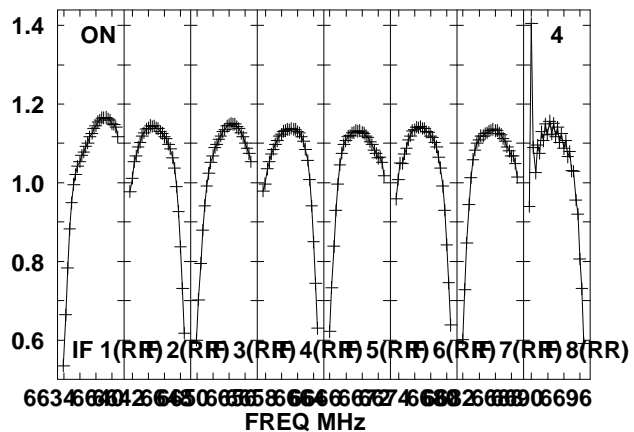
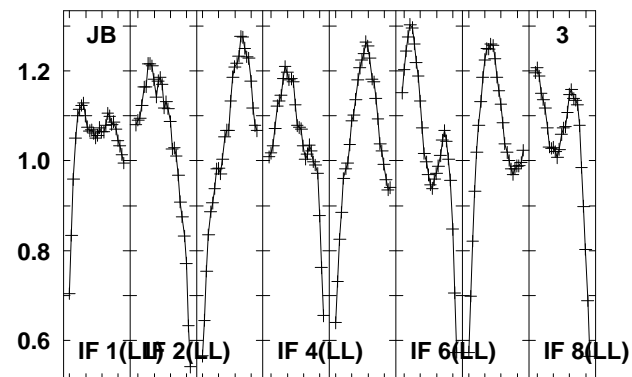
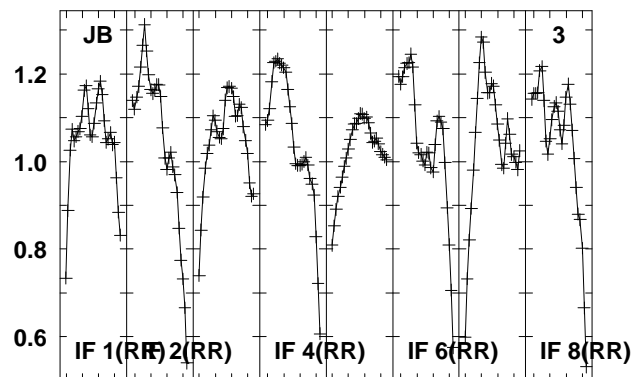
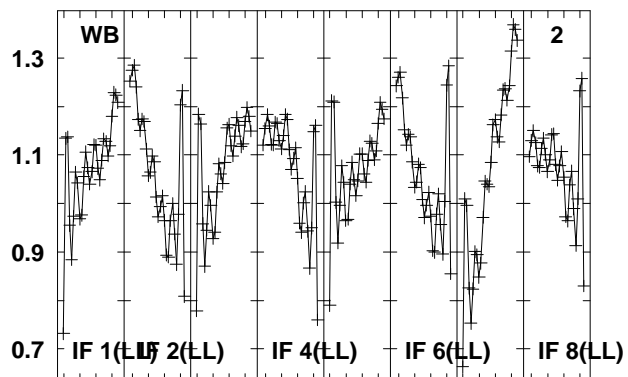
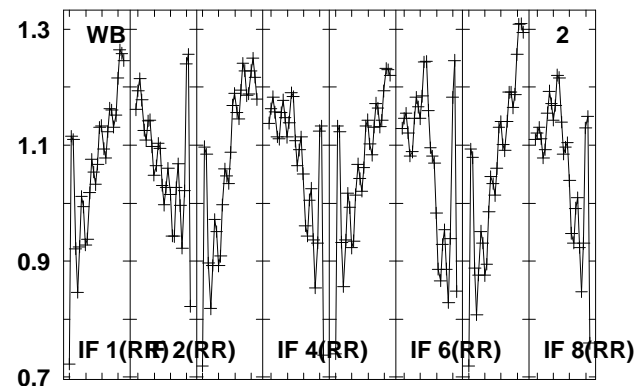
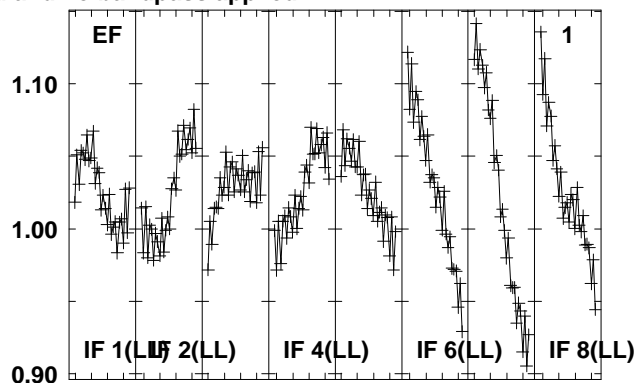
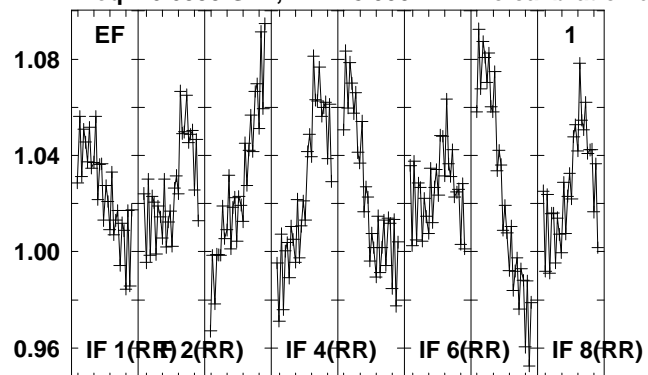

Lower frame: Real Jy
 Total-power spectrum Antenna: *
 Timerange: 00/12:24:21 to 00/12:25:49

Plot file version 106 created 15-MAR-2012 17:31:38

2102-G85 EZ020E 2.UVDATA.1

Freq = 6.6335 GHz, Bw = 8.000 MH No calibration applied and no bandpass applied

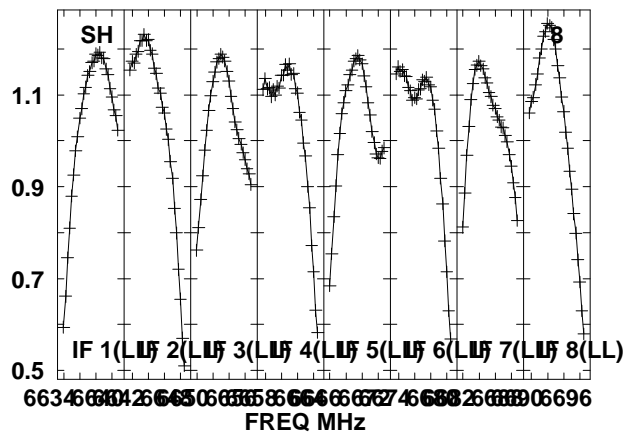
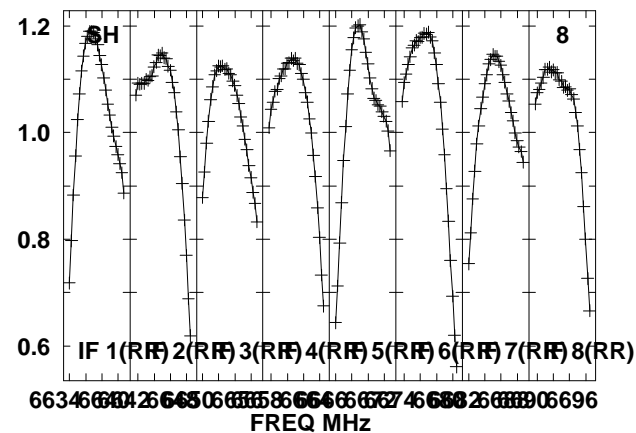
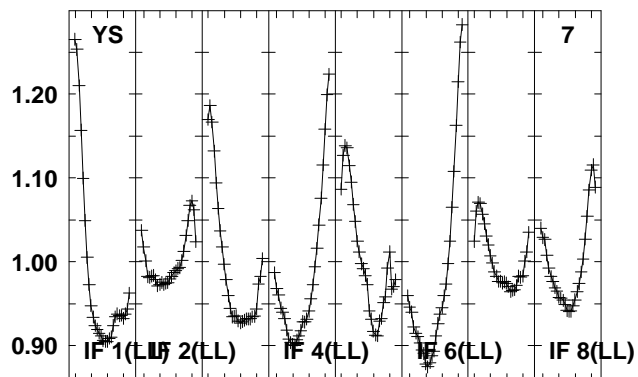
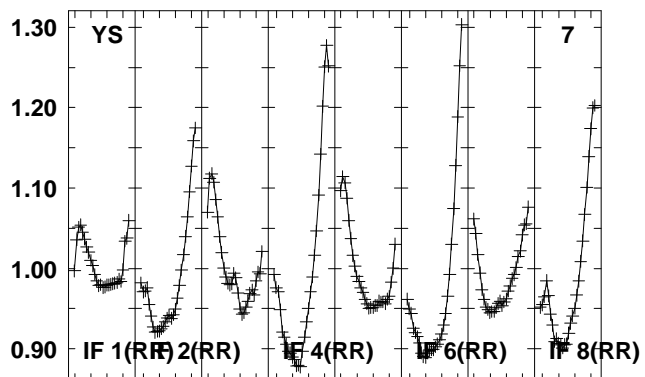
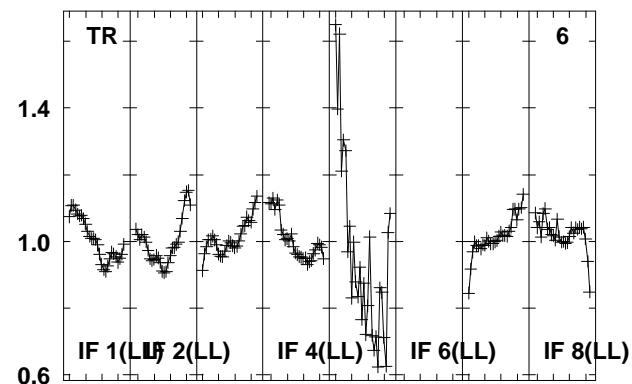
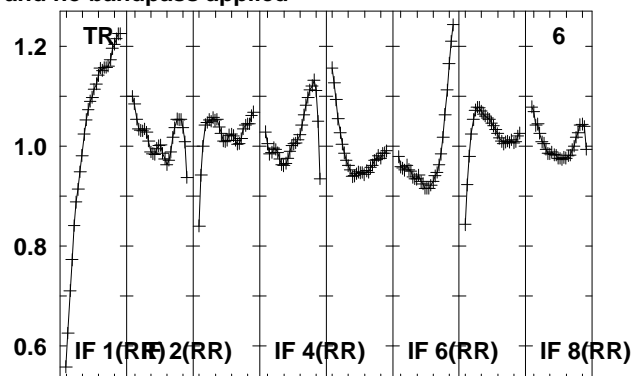
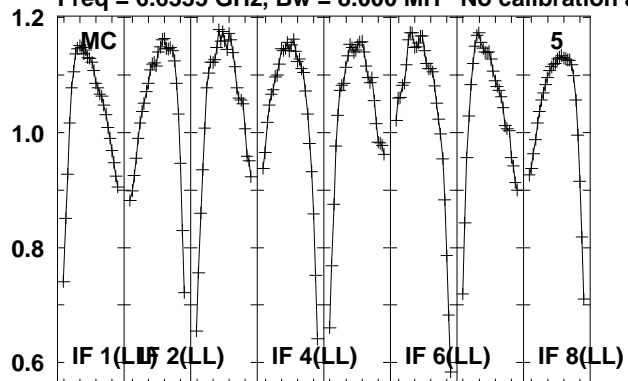

Lower frame: Real Jy

Total-power spectrum Antenna: *

Timerange: 00/12:24:21 to 00/12:25:49

Plot file version 107 created 15-MAR-2012 17:31:39

G85.40 EZ020E 2.UVDATA.1

Freq = 6.6335 GHz, Bw = 8.000 MH No calibration applied and no bandpass applied

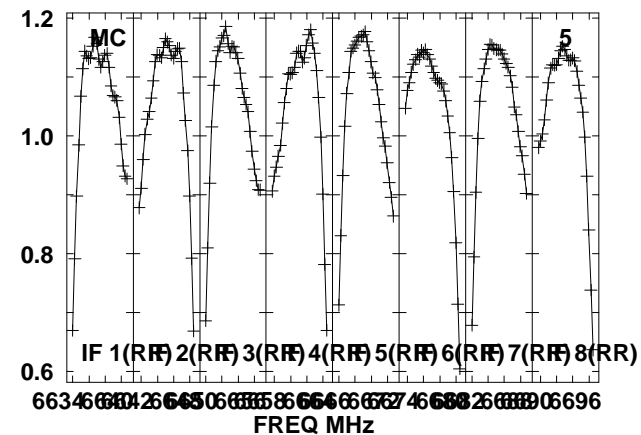
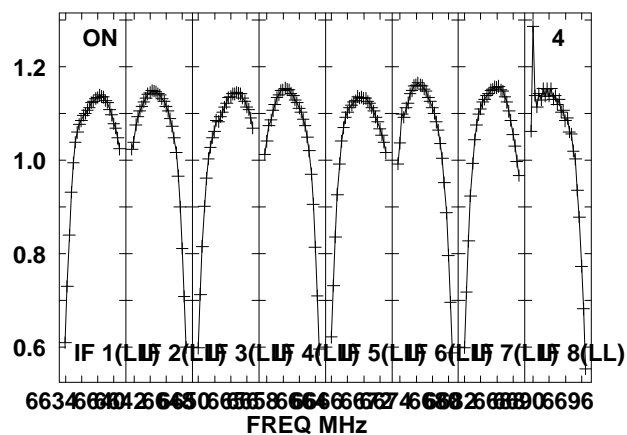
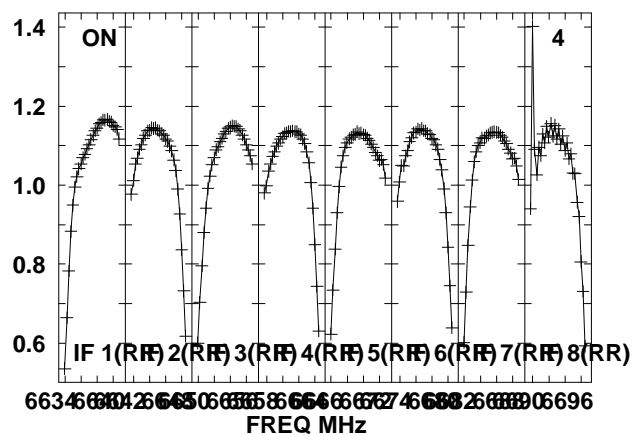
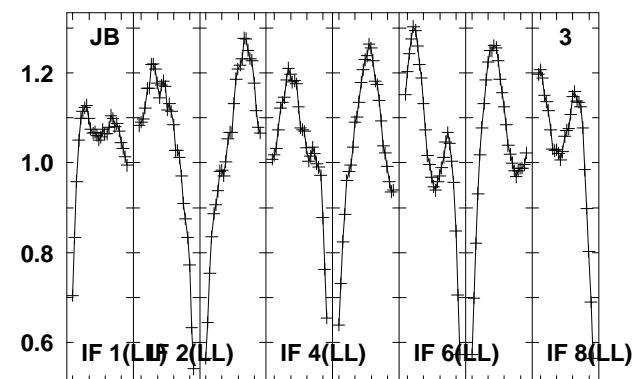
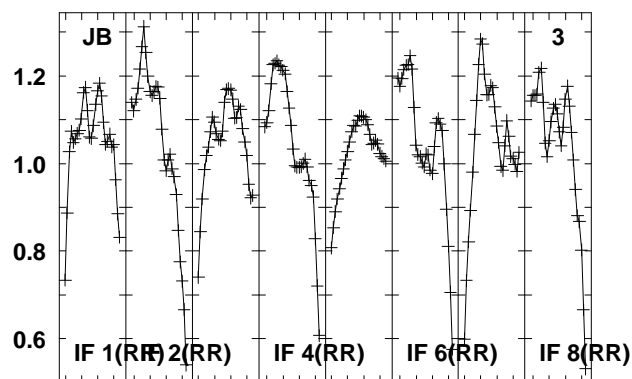
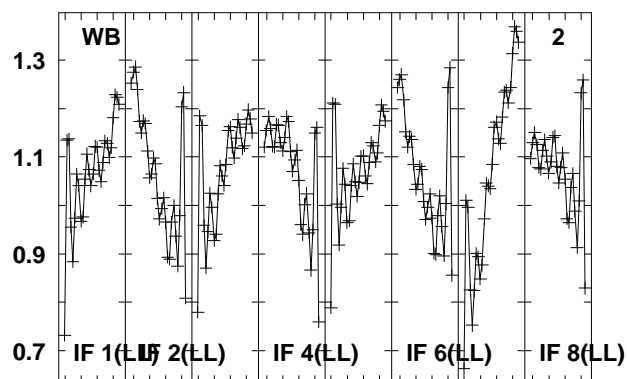
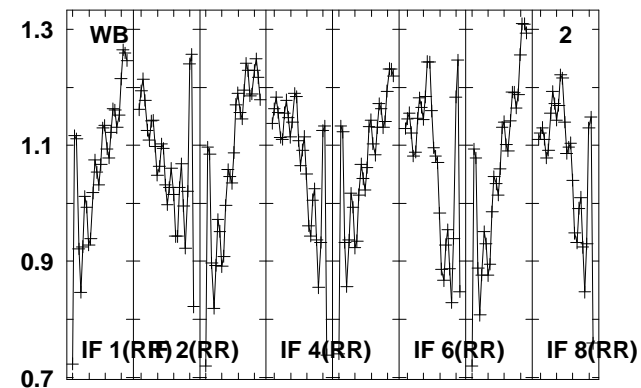
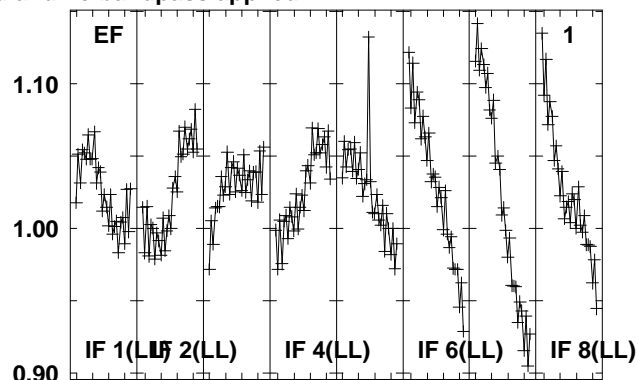
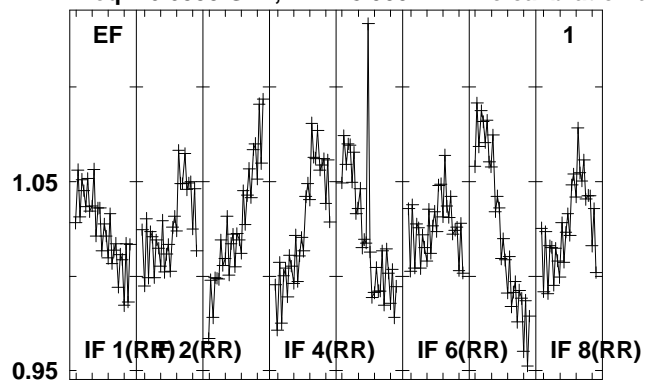

Lower frame: Real Jy
Total-power spectrum Antenna: *
Timerange: 00/12:26:26 to 00/12:27:23

Plot file version 108 created 15-MAR-2012 17:31:39

G85.40 EZ020E 2.UVDATA.1

Freq = 6.6335 GHz, Bw = 8.000 MH No calibration applied and no bandpass applied

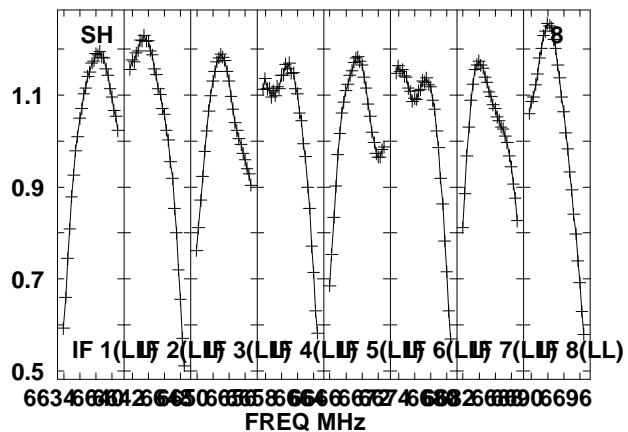
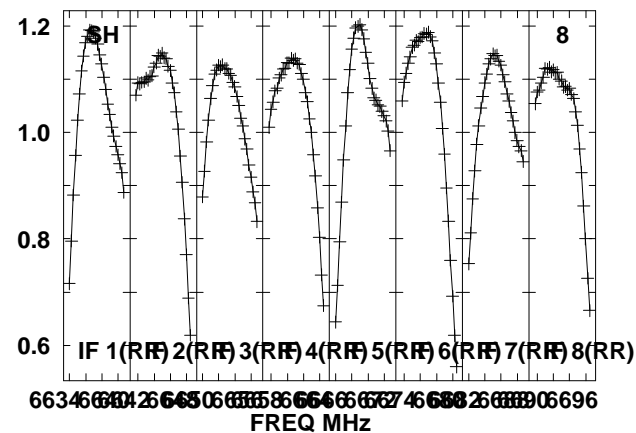
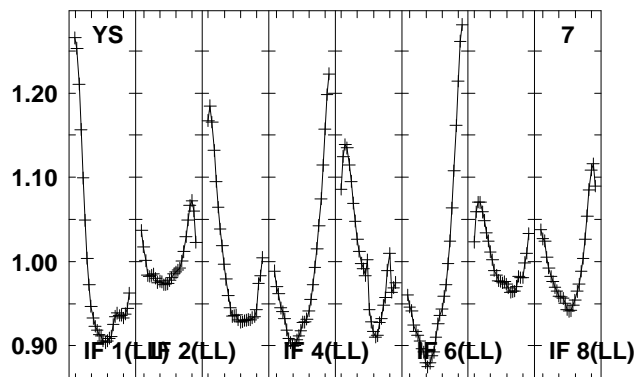
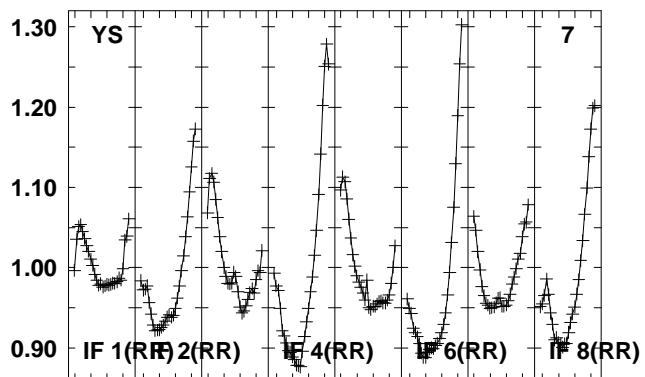
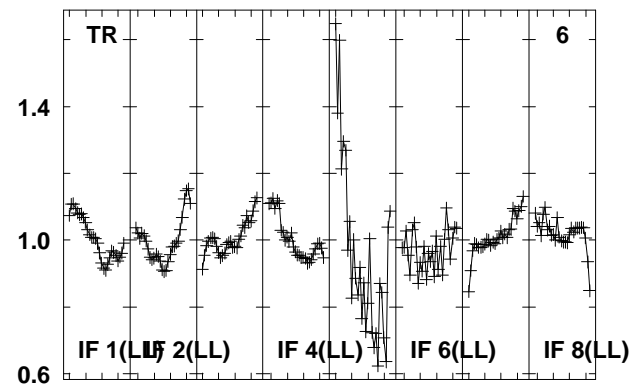
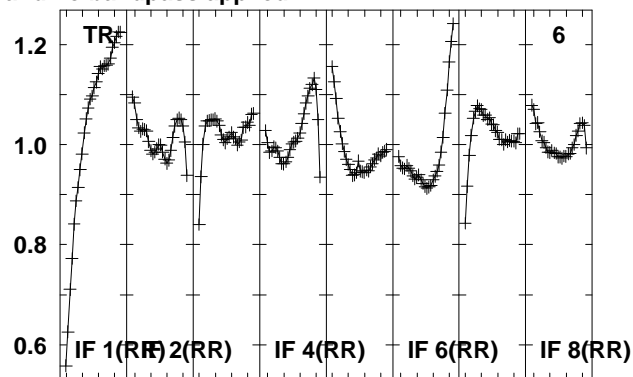
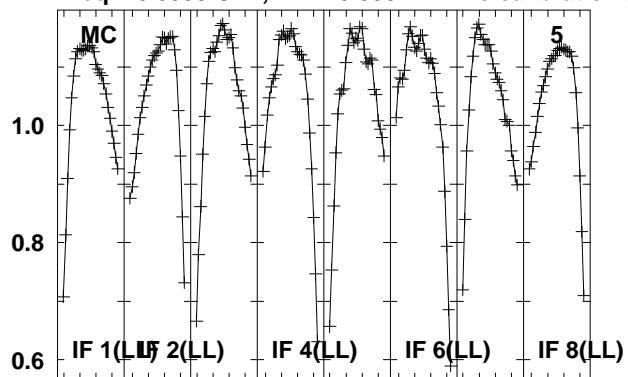

Lower frame: Real Jy

Total-power spectrum Antenna: *

Timerange: 00/12:26:26 to 00/12:27:23

Plot file version 110 created 15-MAR-2012 17:31:41

2114-G85 EZ020E 2.UVDATA.1

Freq = 6.6335 GHz, Bw = 8.000 MH No calibration applied and no bandpass applied

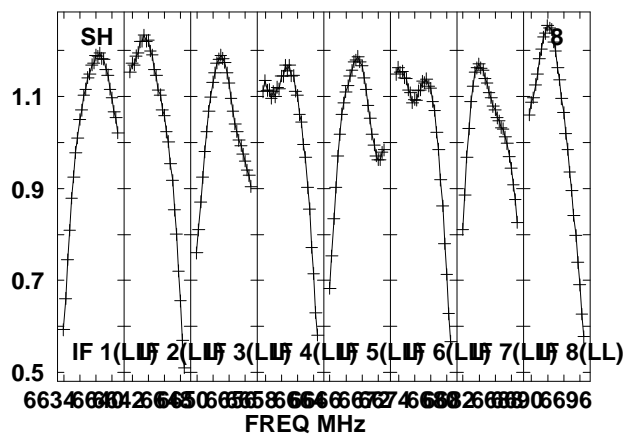
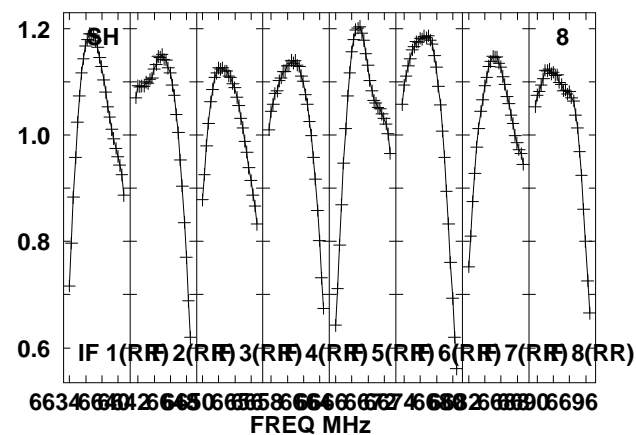
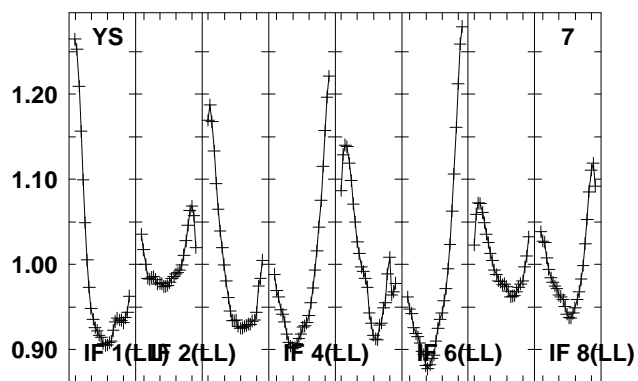
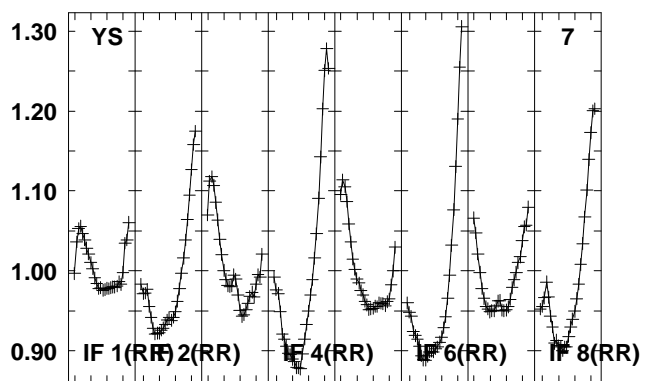
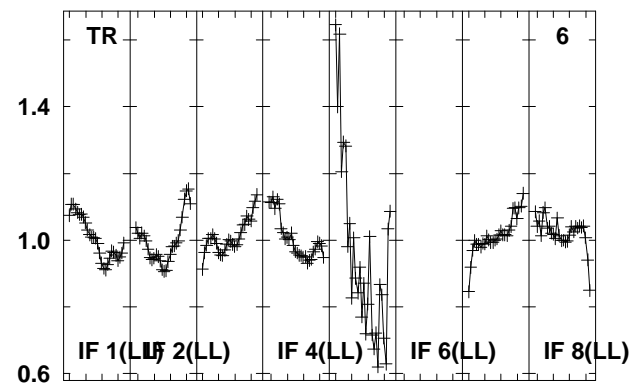
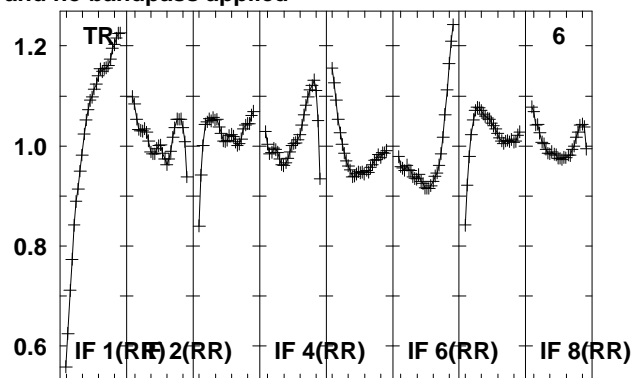
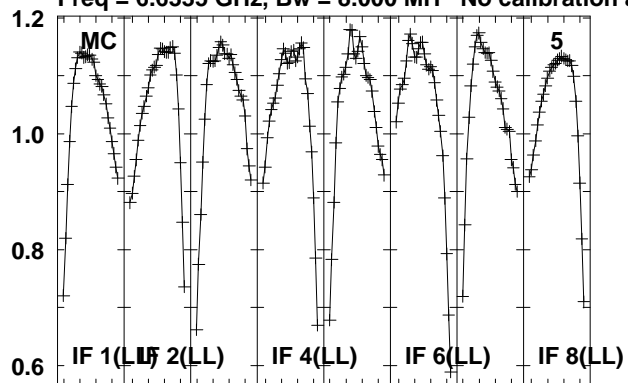

Lower frame: Real Jy

Total-power spectrum Antenna: *

Timerange: 00/12:27:25 to 00/12:28:53

Plot file version 112 created 15-MAR-2012 17:31:42

G85.40 EZ020E 2.UVDATA.1

Freq = 6.6335 GHz, Bw = 8.000 MH No calibration applied and no bandpass applied

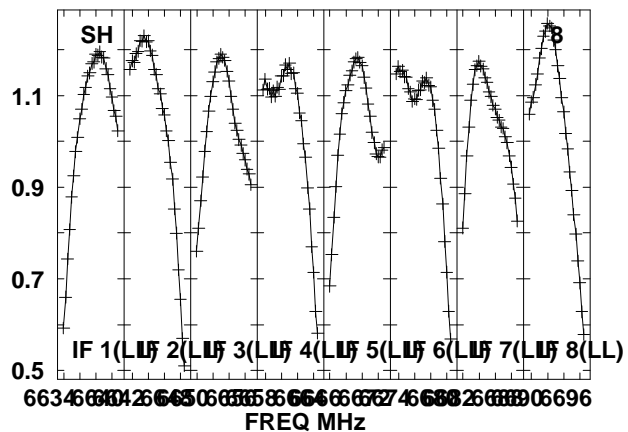
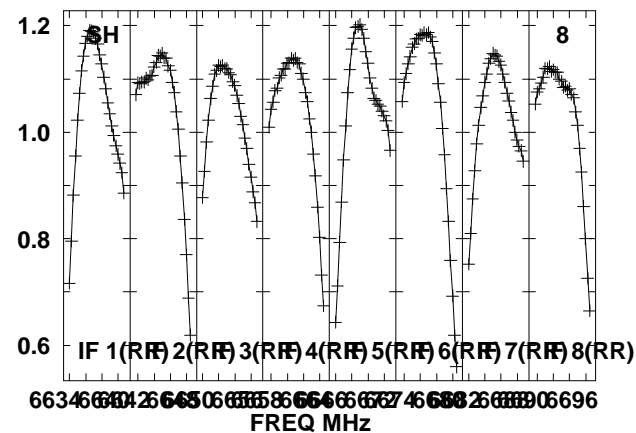
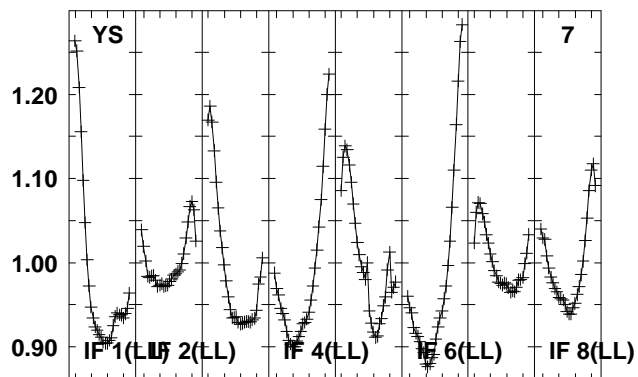
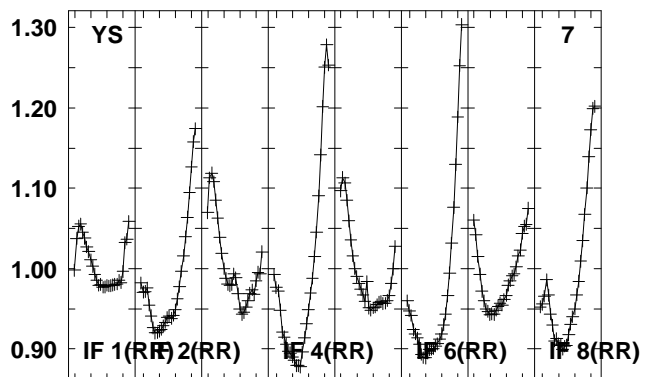
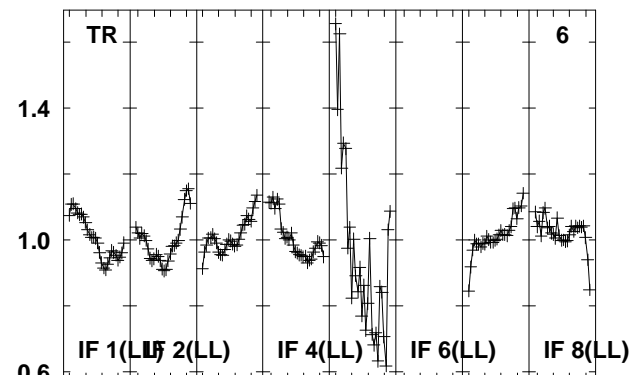
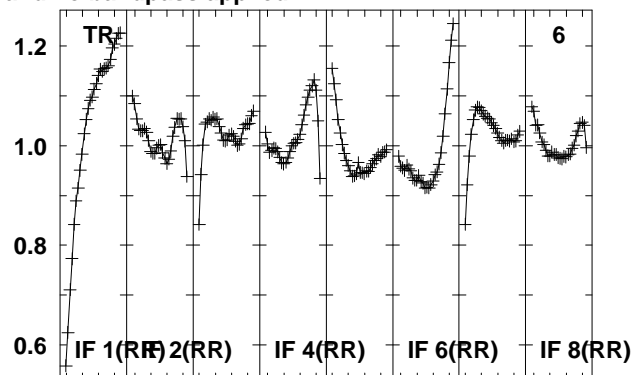
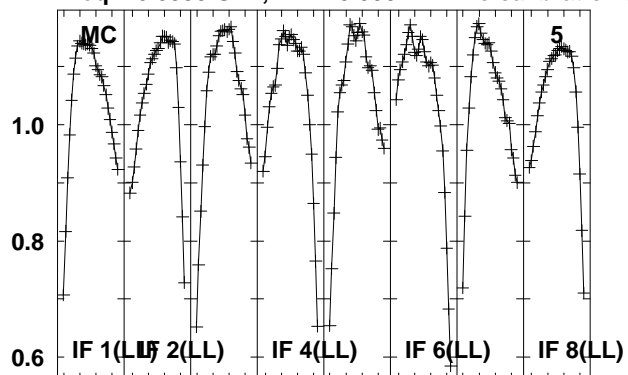

Lower frame: Real Jy

Total-power spectrum Antenna: *

Timerange: 00/12:28:56 to 00/12:30:24

Plot file version 113 created 15-MAR-2012 17:31:43
 2102-G85 EZ020E 2.UVDATA.1
 Freq = 6.6335 GHz, Bw = 8.000 MH No calibration applied and no bandpass applied

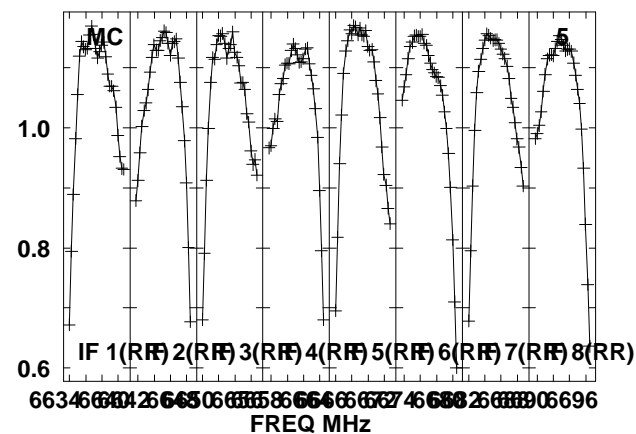
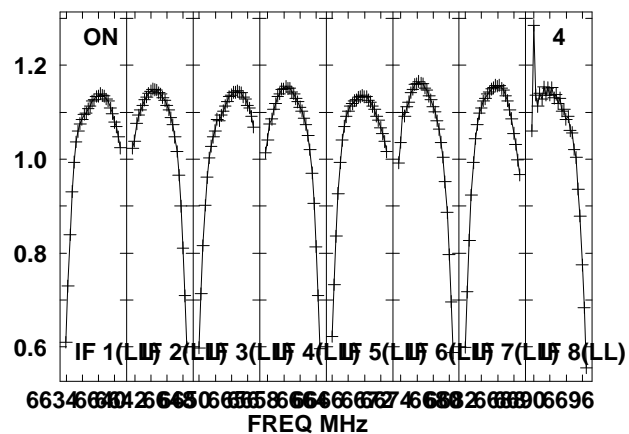
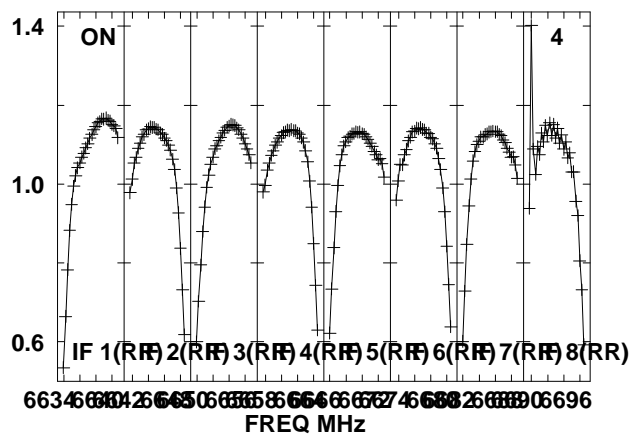
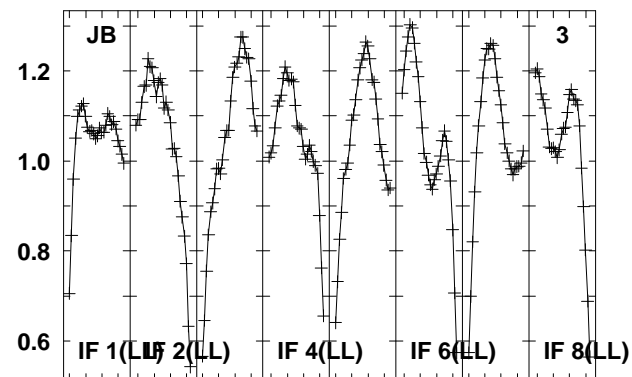
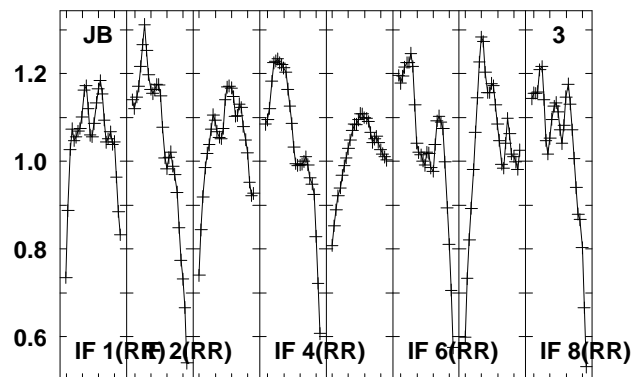
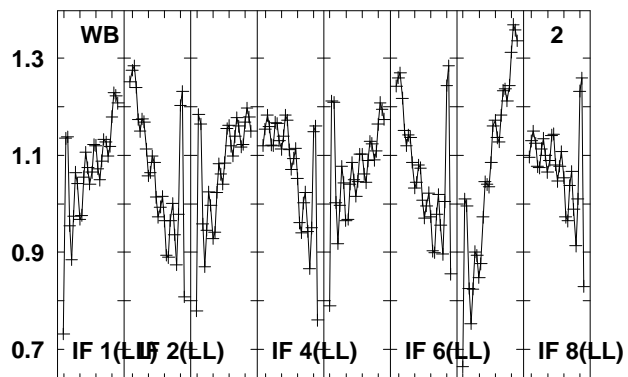
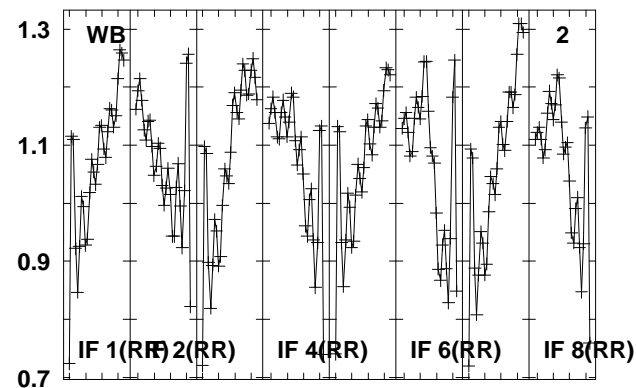
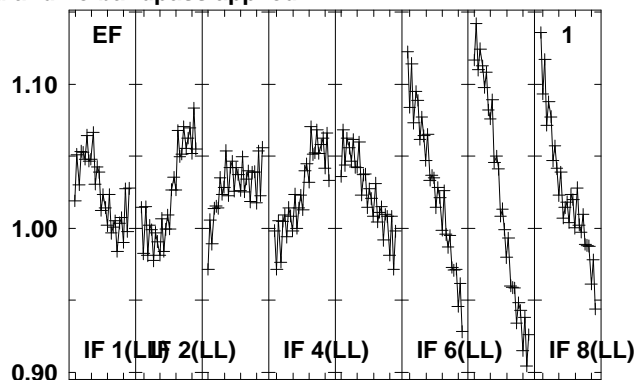
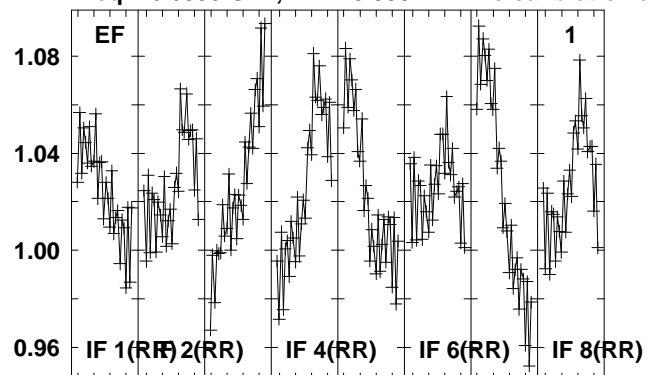

Lower frame: Real Jy
 Total-power spectrum Antenna: *
 Timerange: 00/12:30:26 to 00/12:31:54

Plot file version 114 created 15-MAR-2012 17:31:44

2102-G85 EZ020E 2.UVDATA.1

Freq = 6.6335 GHz, Bw = 8.000 MH No calibration applied and no bandpass applied

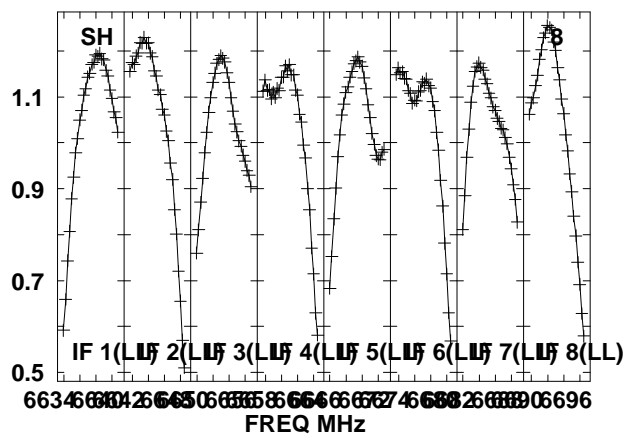
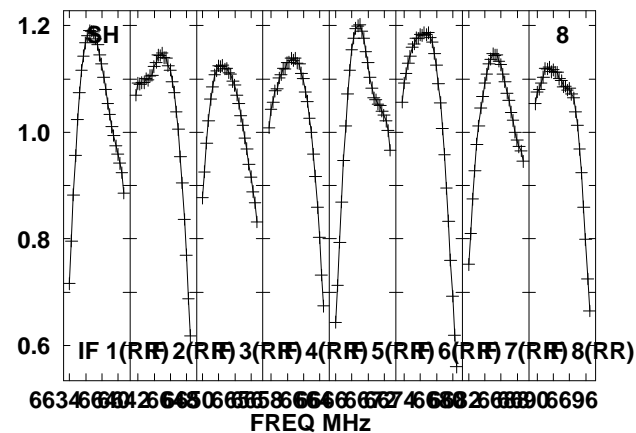
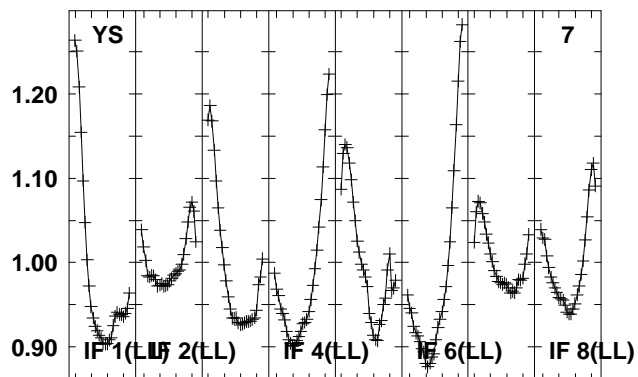
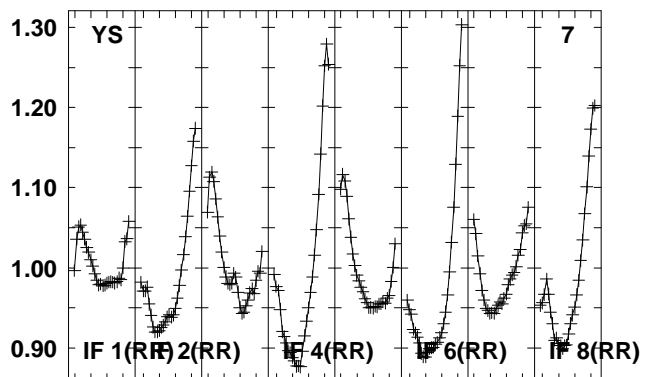
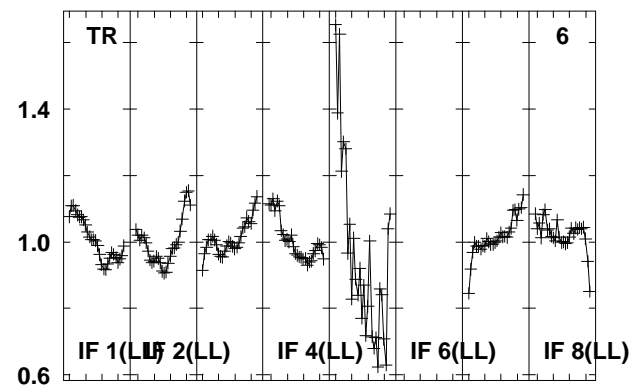
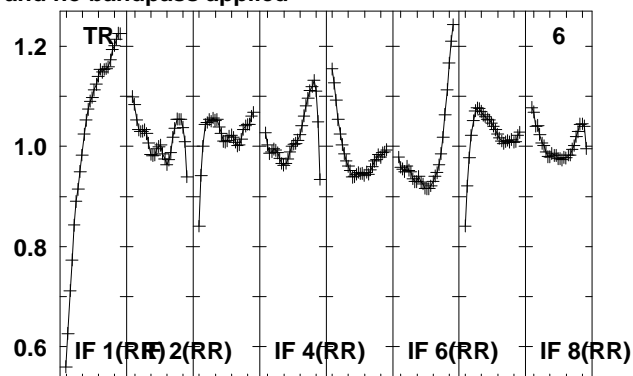
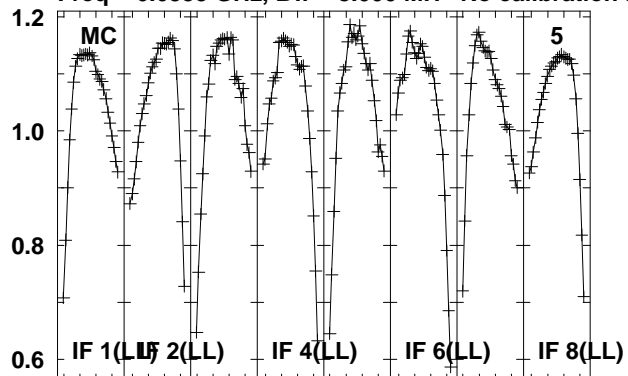

Lower frame: Real Jy

Total-power spectrum Antenna: *

Timerange: 00/12:30:26 to 00/12:31:54

Plot file version 115 created 15-MAR-2012 17:31:45

G85.40 EZ020E 2.UVDATA.1

Freq = 6.6335 GHz, Bw = 8.000 MH No calibration applied and no bandpass applied

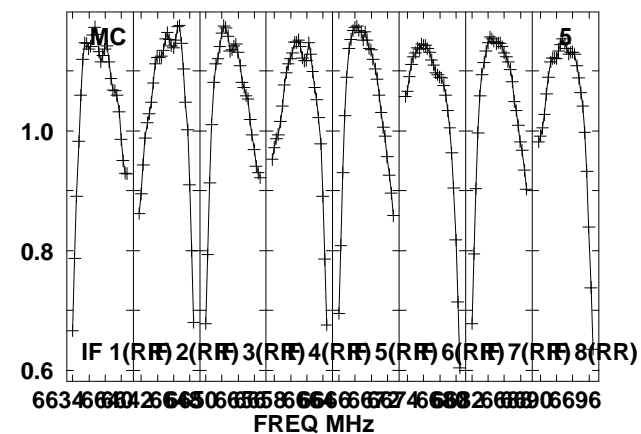
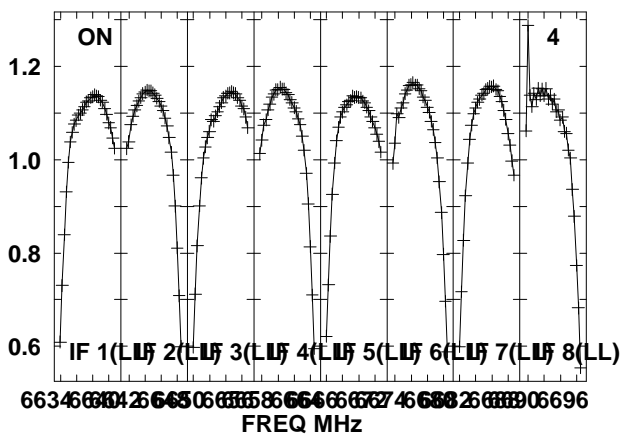
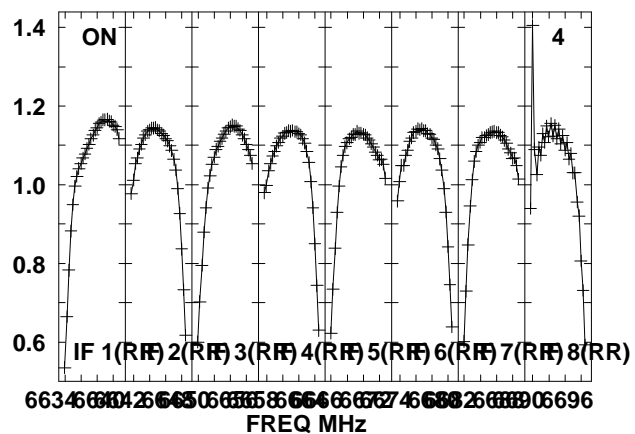
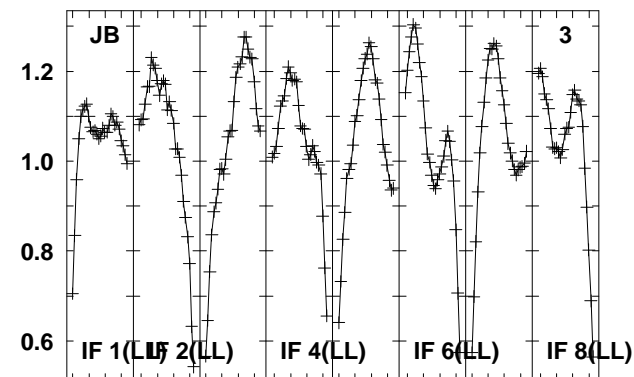
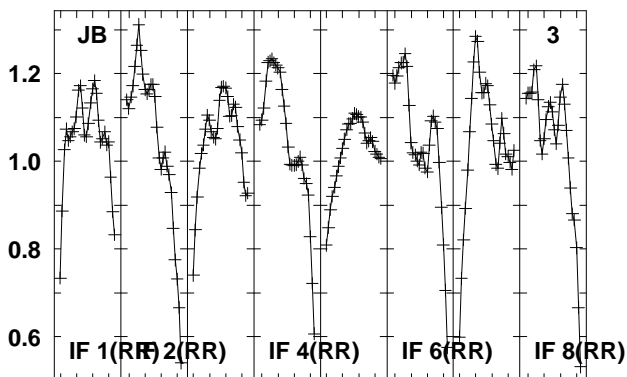
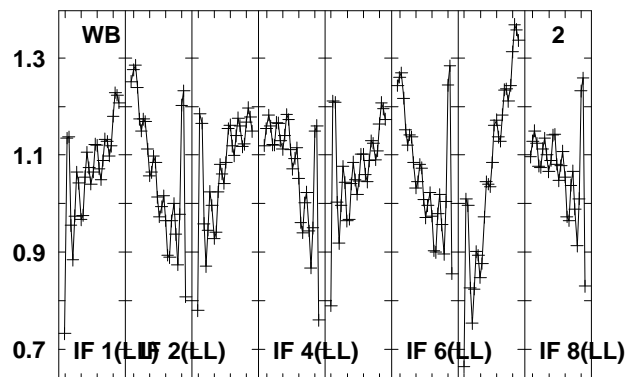
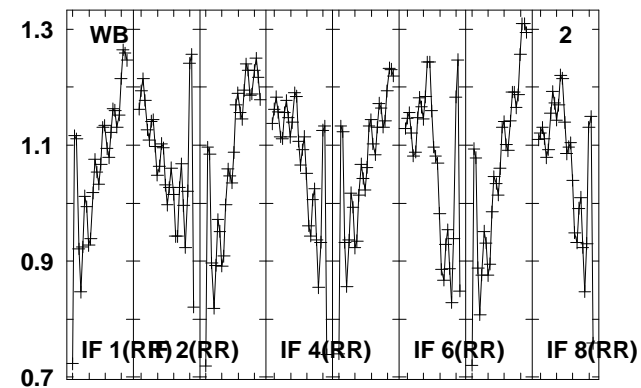
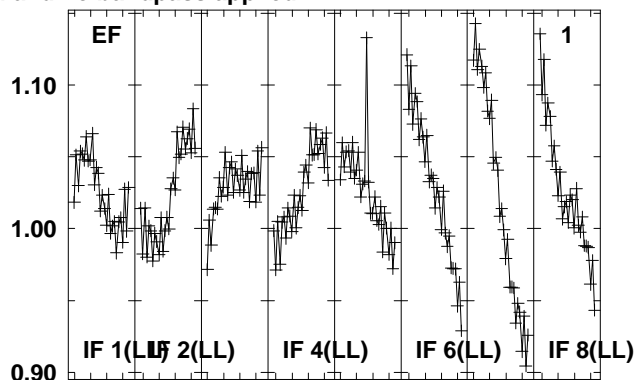
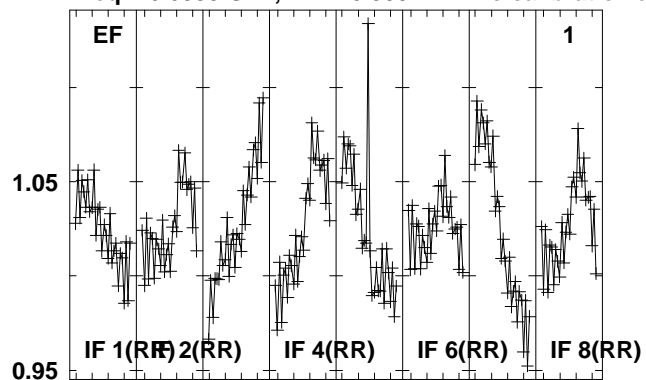

Lower frame: Real Jy

Total-power spectrum Antenna: *

Timerange: 00:12:31:55 to 00:12:33:23

Plot file version 116 created 15-MAR-2012 17:31:46

G85.40 EZ020E 2.UVDATA.1

Freq = 6.6335 GHz, Bw = 8.000 MH No calibration applied and no bandpass applied

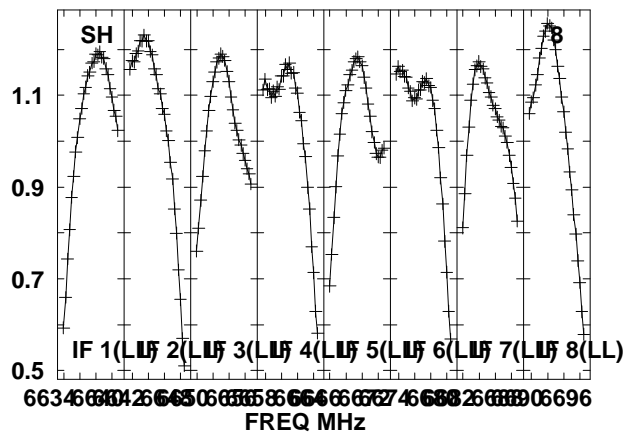
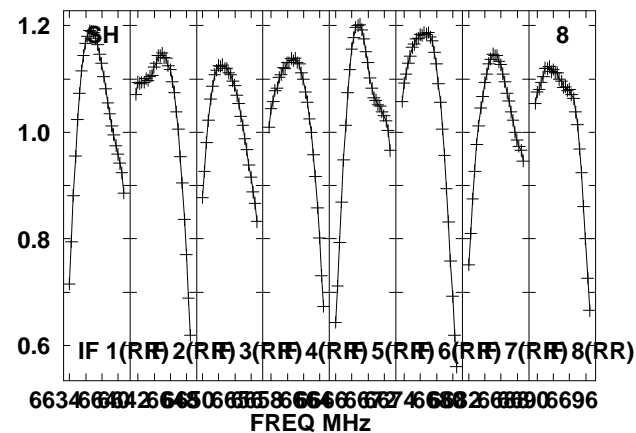
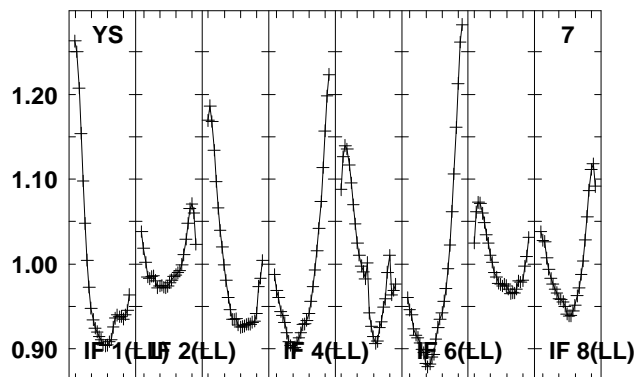
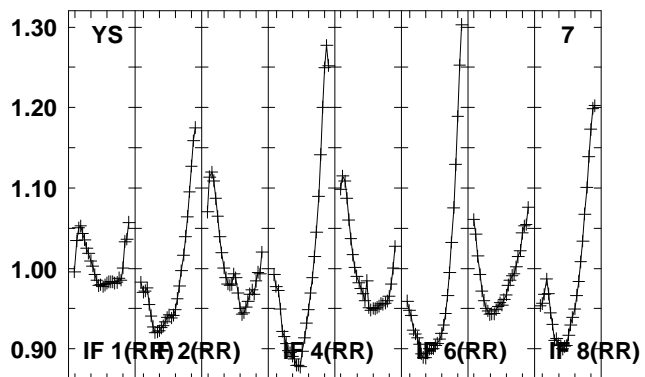
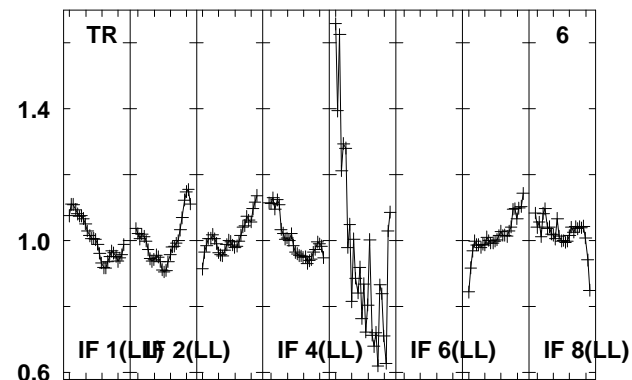
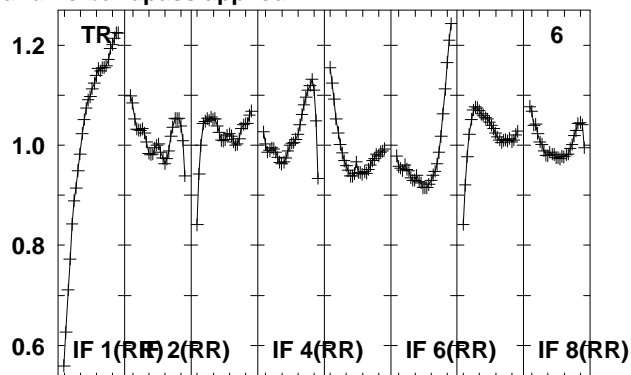
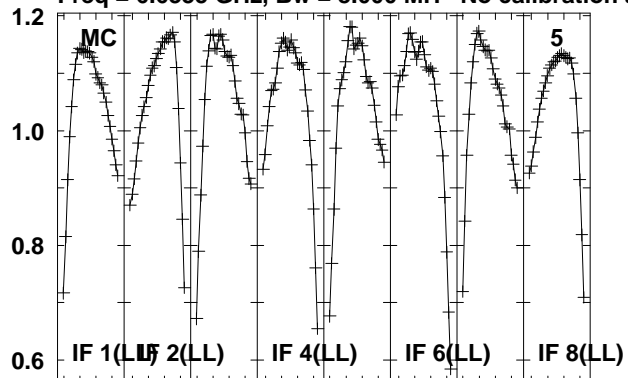

Lower frame: Real Jy

Total-power spectrum Antenna: *

Timerange: 00/12:31:55 to 00/12:33:23

Plot file version 117 created 15-MAR-2012 17:31:47

2114-G85 EZ020E 2.UVDATA.1

Freq = 6.6335 GHz, Bw = 8.000 MH No calibration applied and no bandpass applied

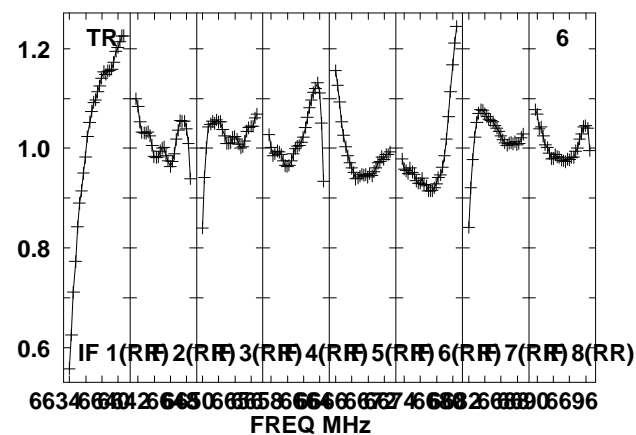
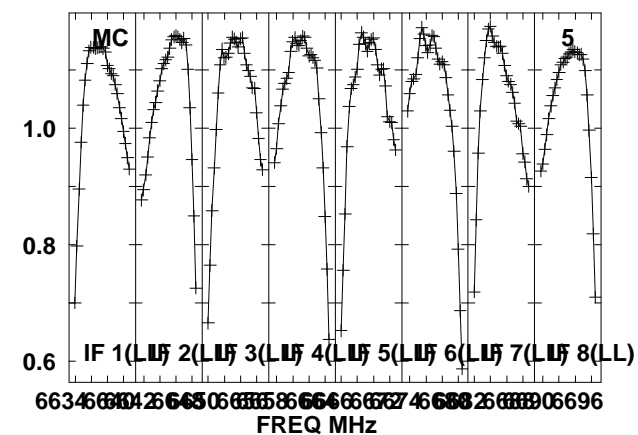
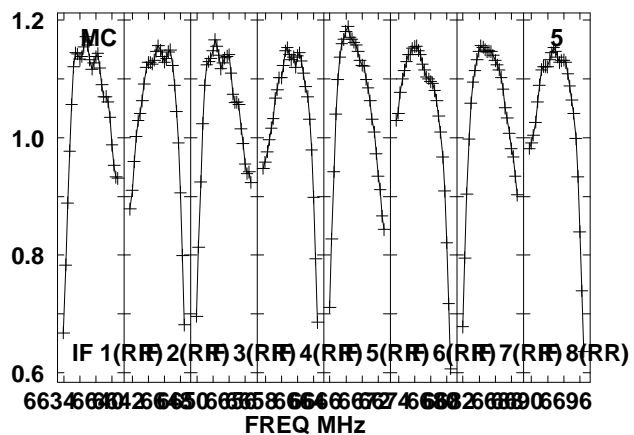
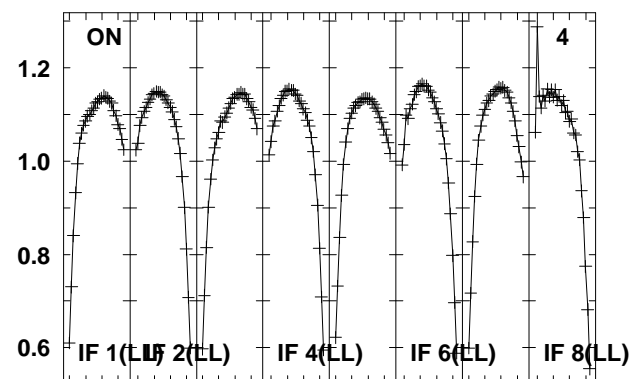
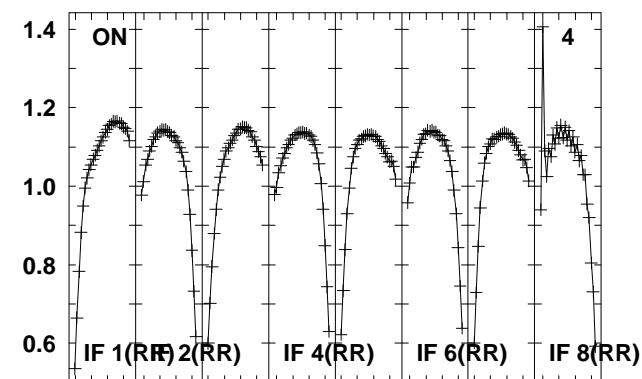
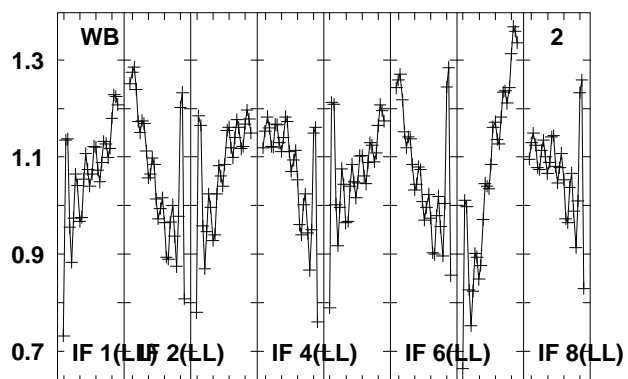
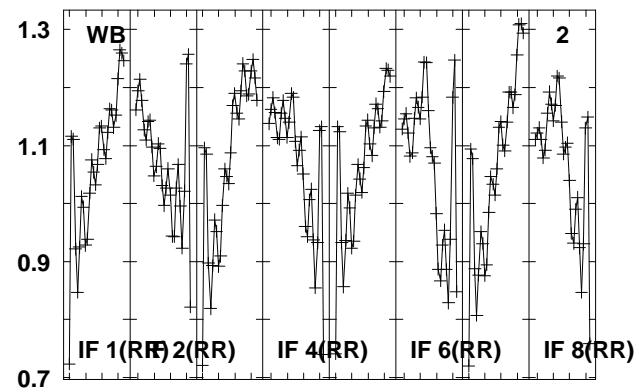
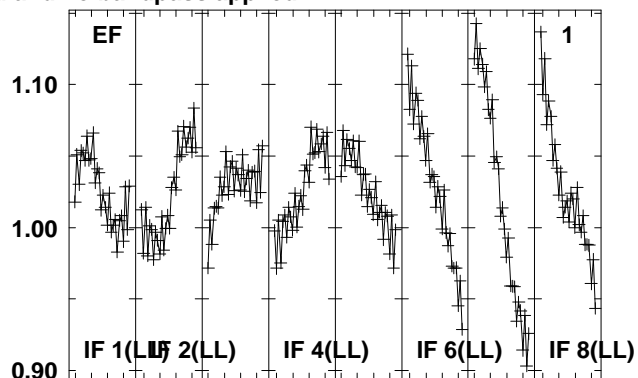
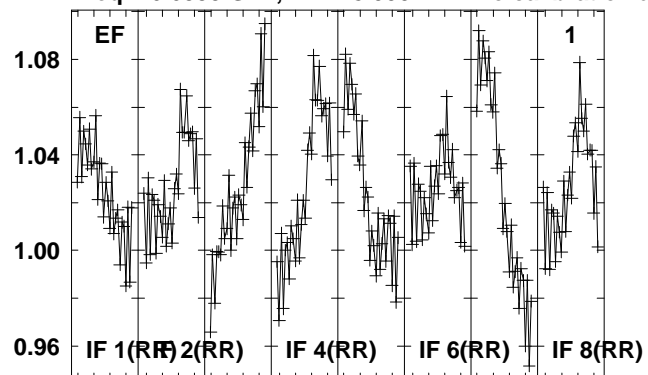

Lower frame: Real Jy

Total-power spectrum Antenna: *

Timerange: 00/12:33:25 to 00/12:34:53

Plot file version 118 created 15-MAR-2012 17:31:47

2114-G85 EZ020E 2.UVDATA.1

Freq = 6.6335 GHz, Bw = 8.000 MH No calibration applied and no bandpass applied

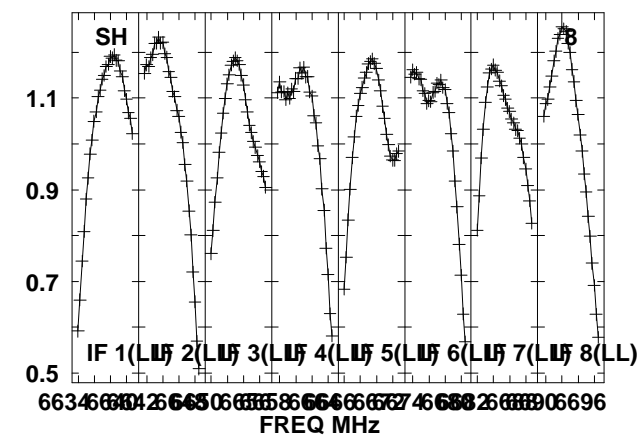
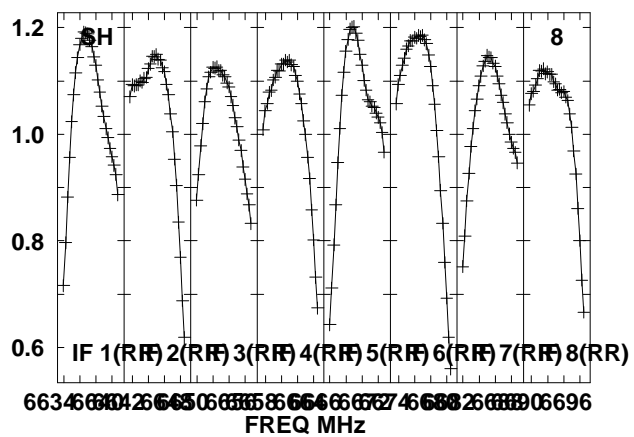
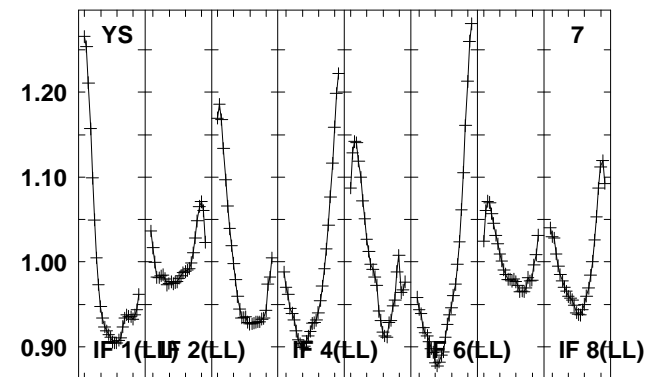
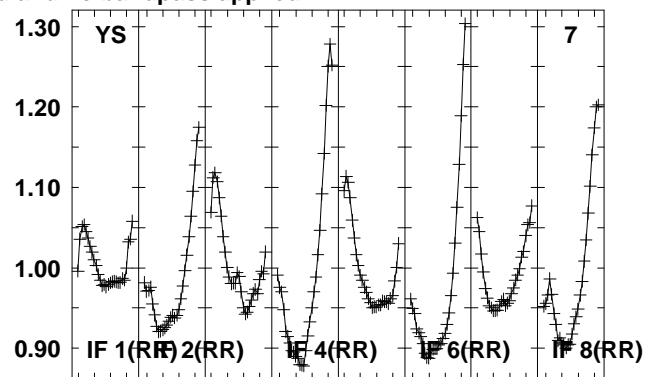
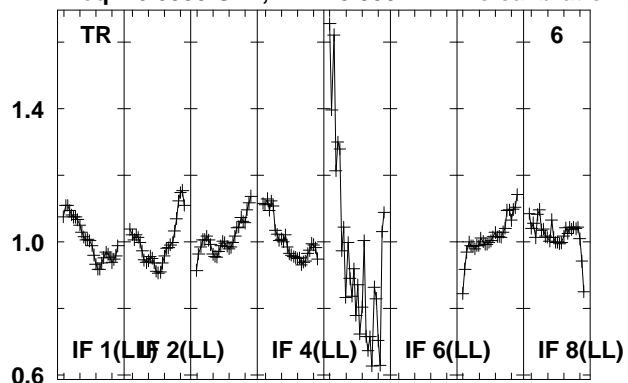

Lower frame: Real Jy
Total-power spectrum Antenna: *
Timerange: 00/12:33:25 to 00/12:34:53

Plot file version 119 created 15-MAR-2012 17:31:48

G85.40 EZ020E 2.UVDATA.1

Freq = 6.6335 GHz, Bw = 8.000 MH No calibration applied and no bandpass applied

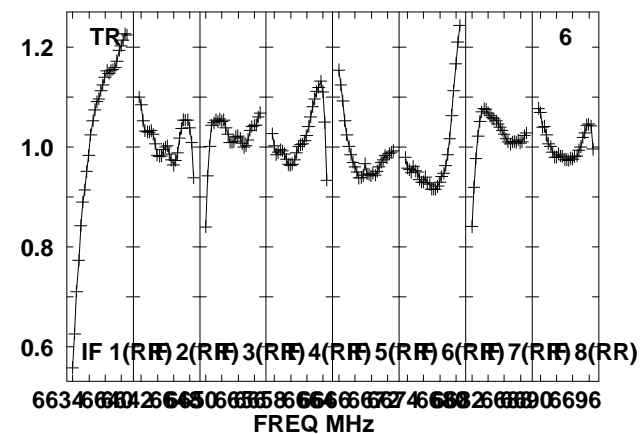
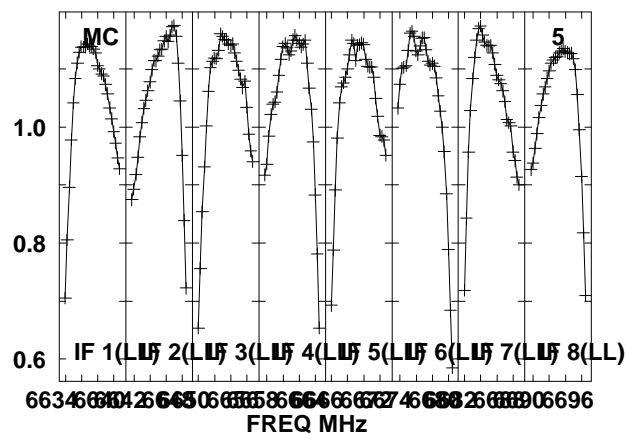
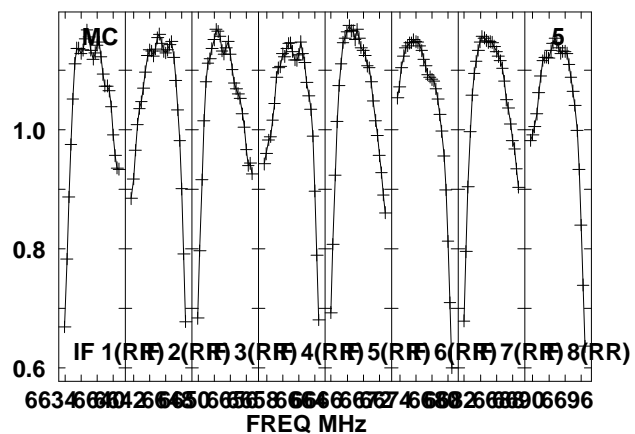
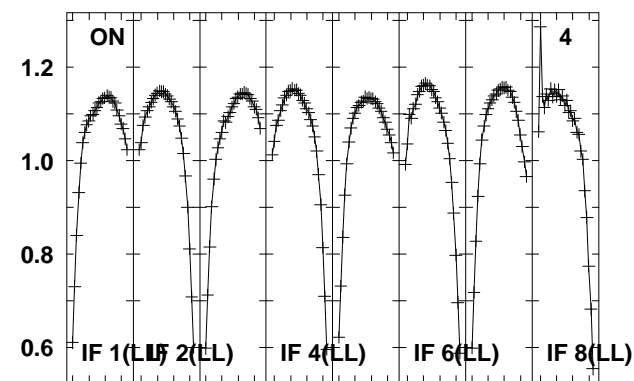
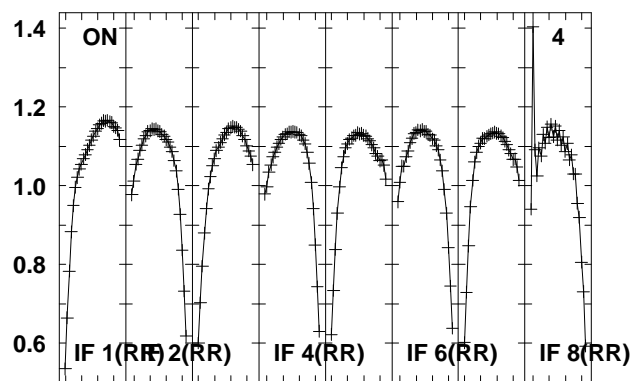
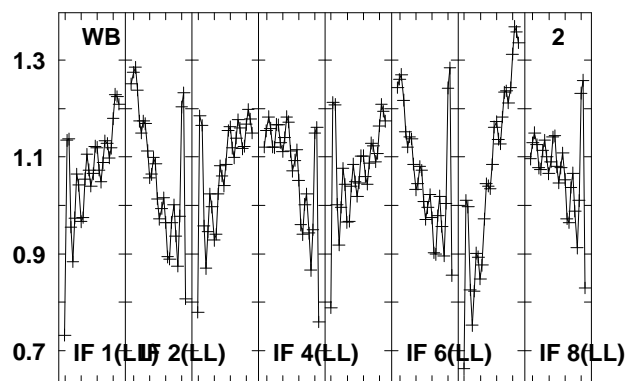
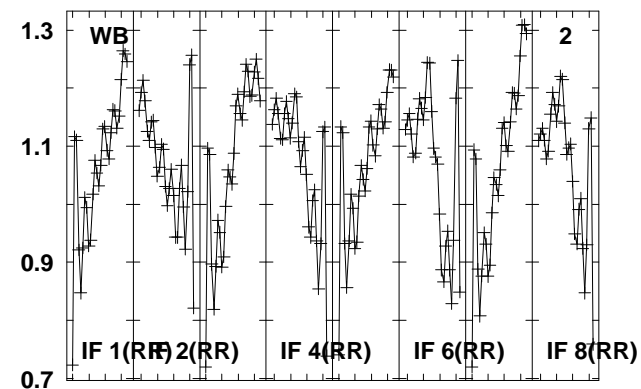
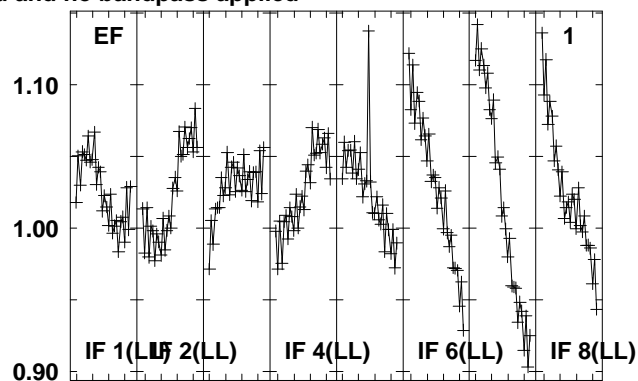
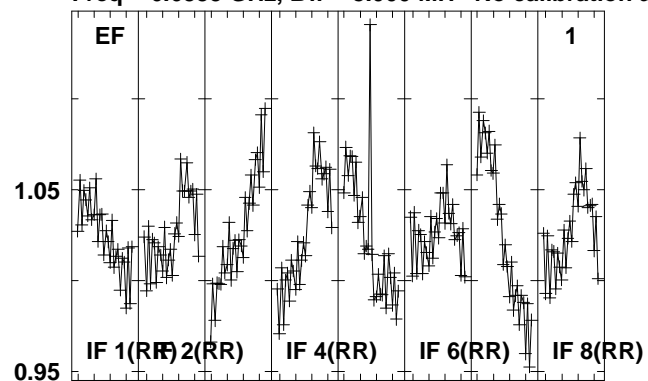

Lower frame: Real Jy

Total-power spectrum Antenna: *

Timerange: 00/12:34:56 to 00/12:36:24

Plot file version 120 created 15-MAR-2012 17:31:48

G85.40 EZ020E 2.UVDATA.1

Freq = 6.6335 GHz, Bw = 8.000 MH No calibration applied and no bandpass applied

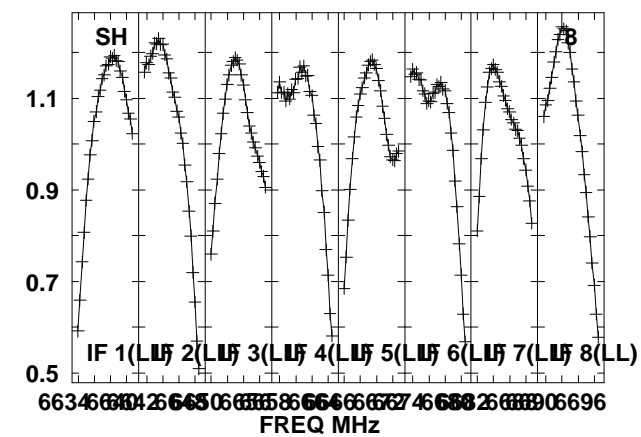
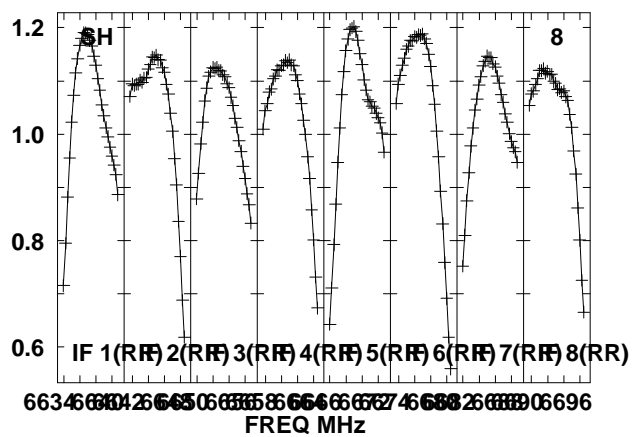
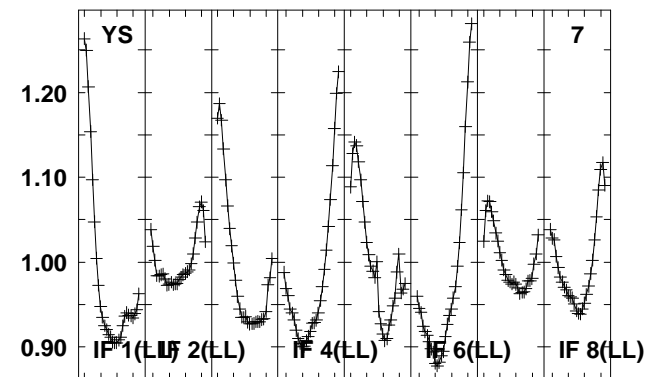
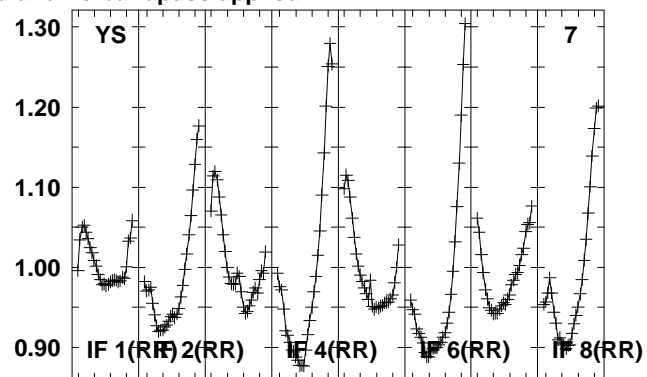
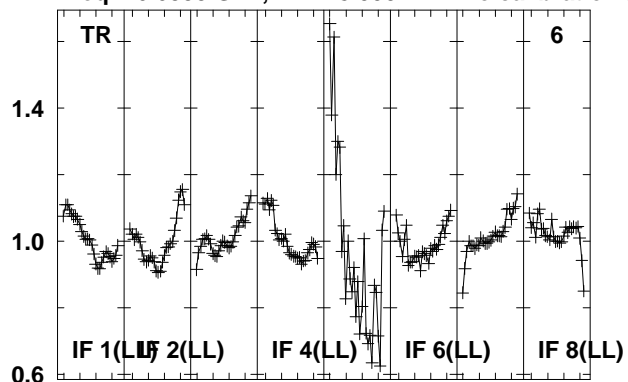

Lower frame: Real Jy
Total-power spectrum Antenna: *
Timerange: 00/12:34:56 to 00/12:36:24

Plot file version 121 created 15-MAR-2012 17:31:49

2102-G85 EZ020E 2.UVDATA.1

Freq = 6.6335 GHz, Bw = 8.000 MH No calibration applied and no bandpass applied

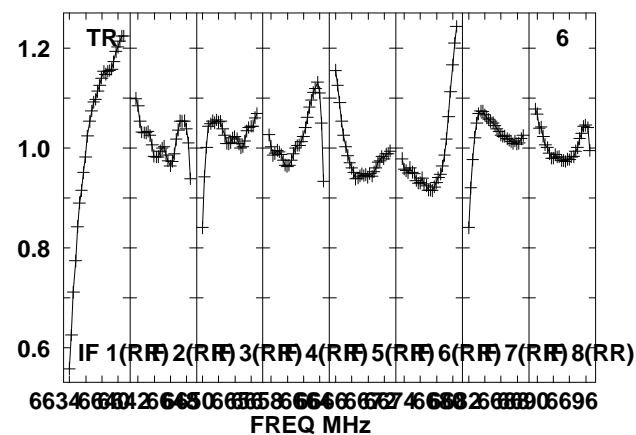
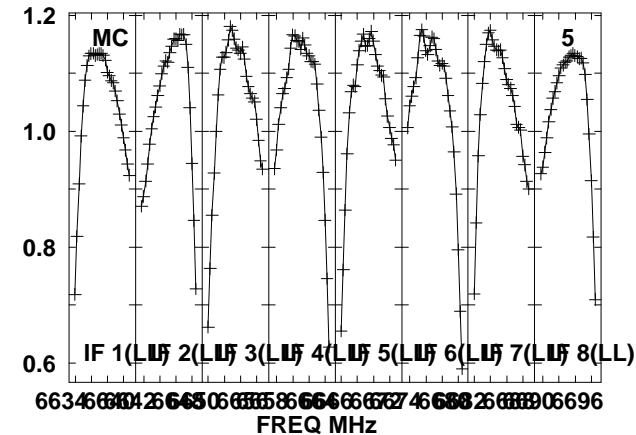
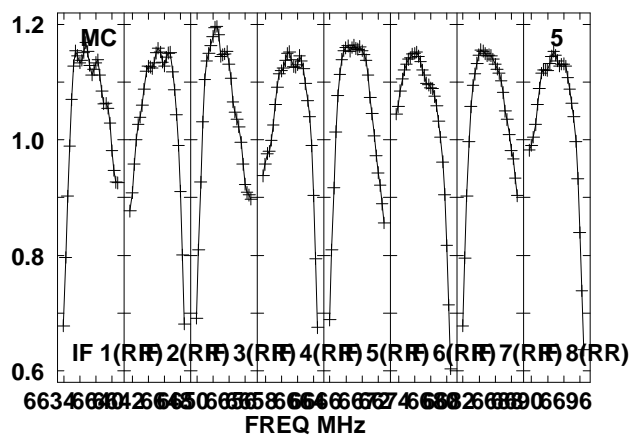
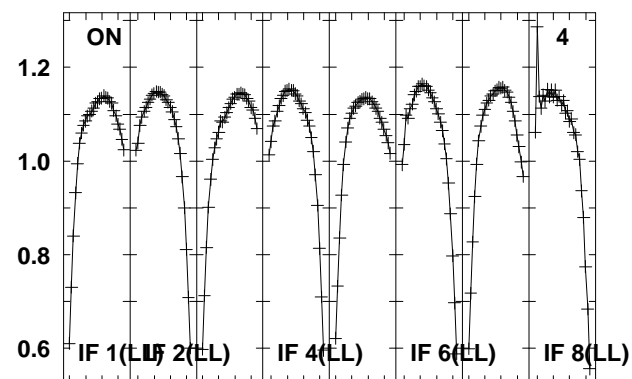
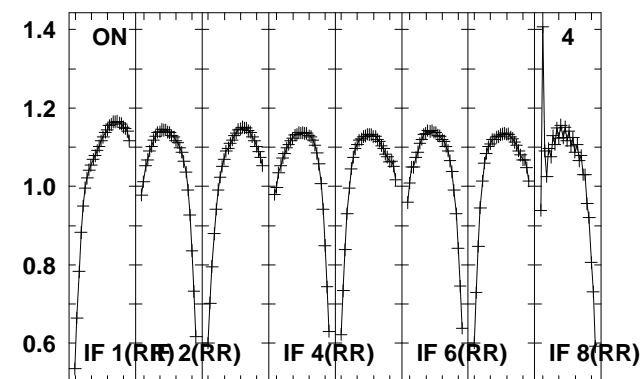
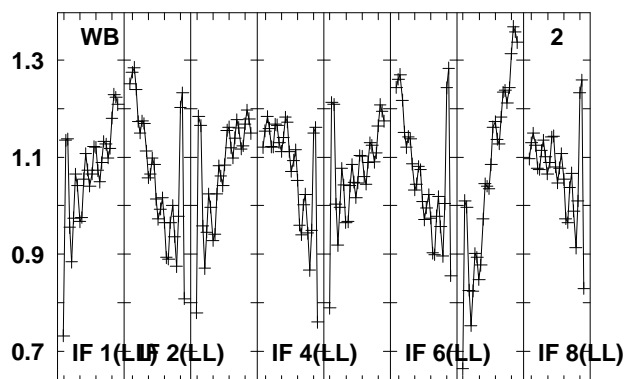
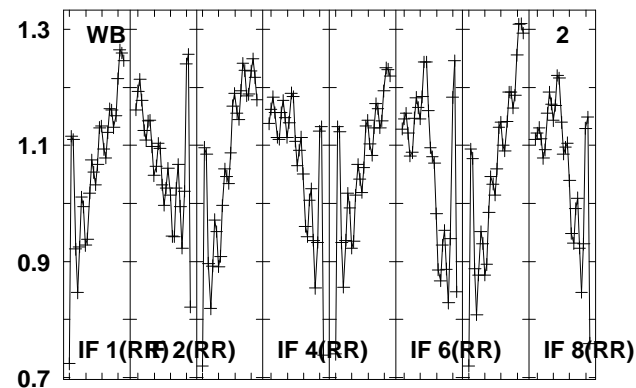
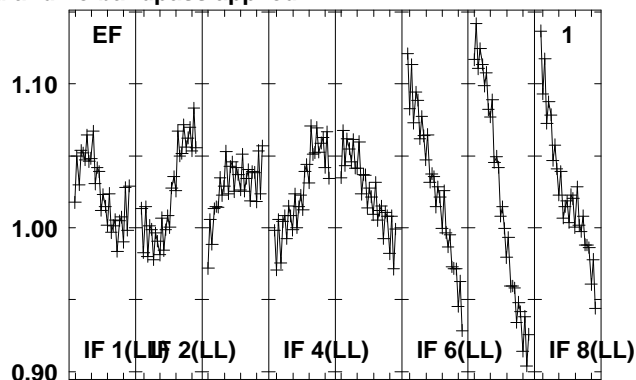
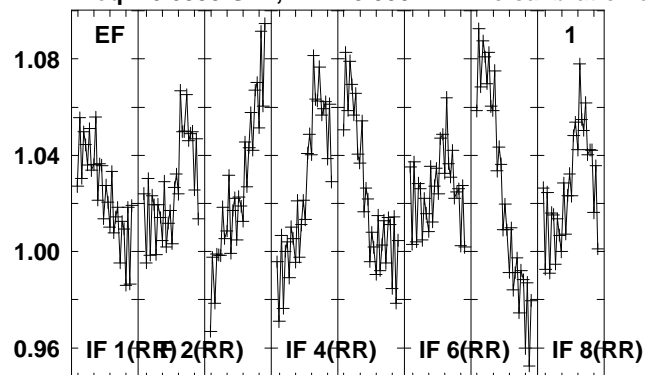

Lower frame: Real Jy
Total-power spectrum Antenna: *
Timerange: 00/12:36:25 to 00/12:37:54

Plot file version 122 created 15-MAR-2012 17:31:49

2102-G85 EZ020E 2.UVDATA.1

Freq = 6.6335 GHz, Bw = 8.000 MH No calibration applied and no bandpass applied

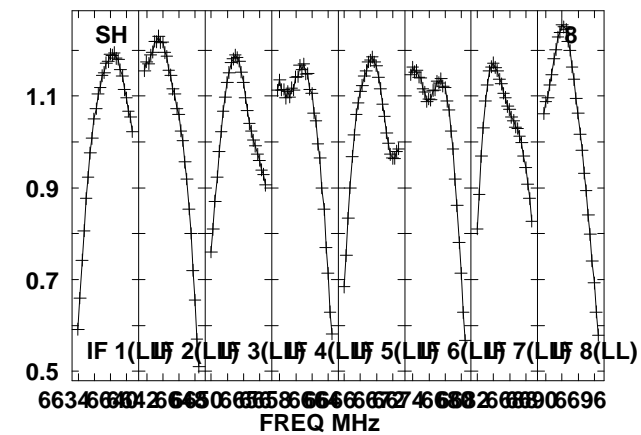
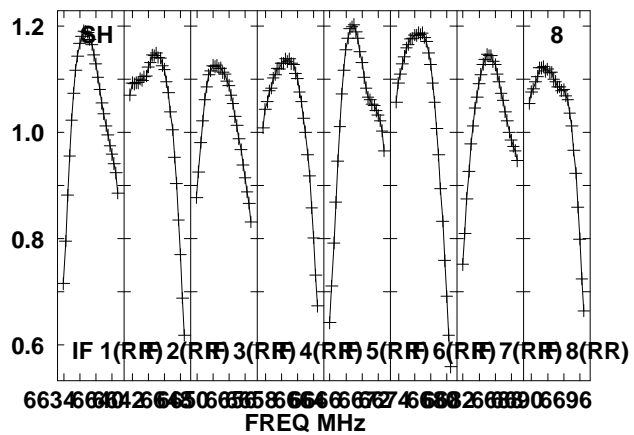
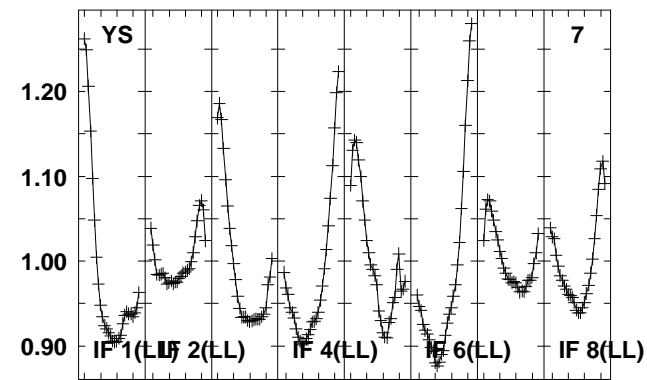
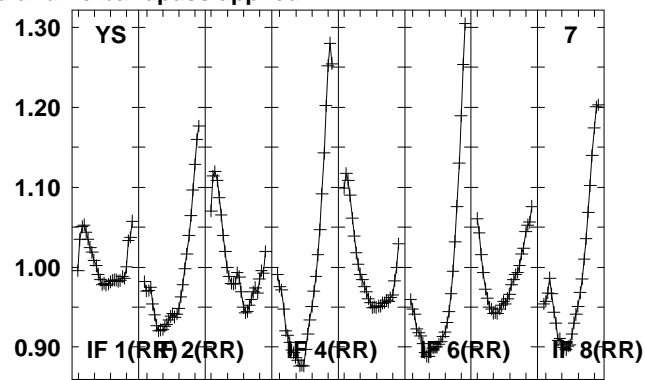
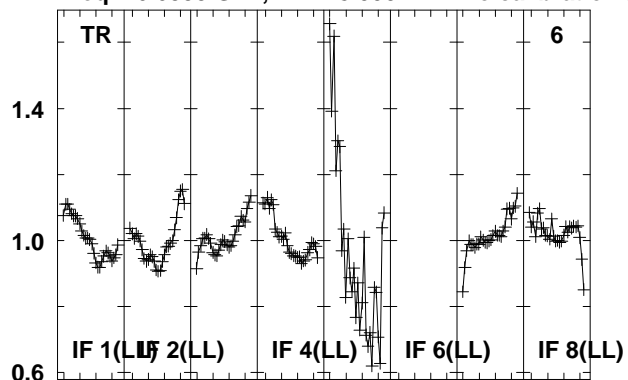

Lower frame: Real Jy
Total-power spectrum Antenna: *
Timerange: 00/12:36:25 to 00/12:37:54

Plot file version 123 created 15-MAR-2012 17:31:51

G85.40 EZ020E 2.UVDATA.1

Freq = 6.6335 GHz, Bw = 8.000 MH No calibration applied and no bandpass applied

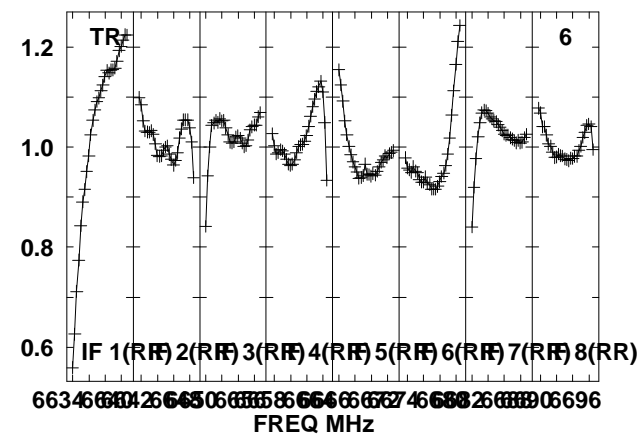
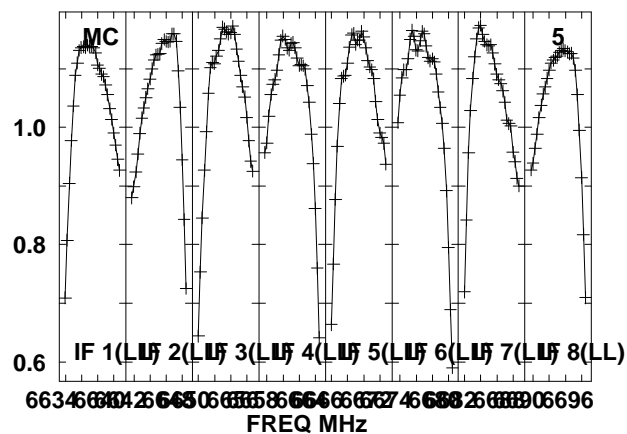
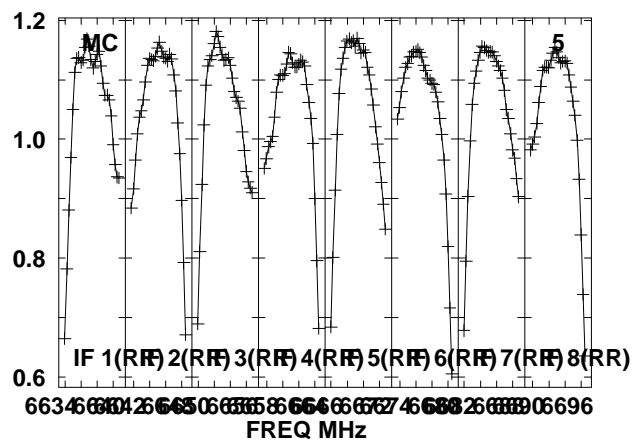
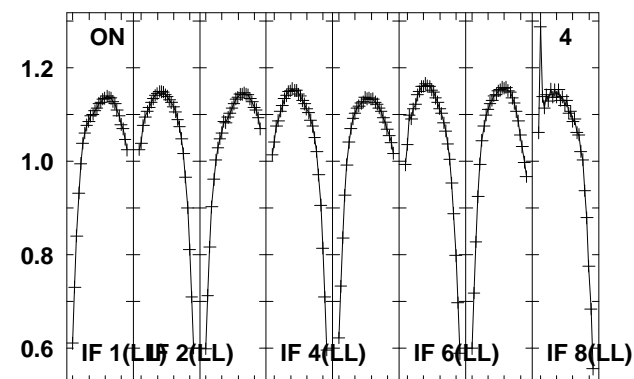
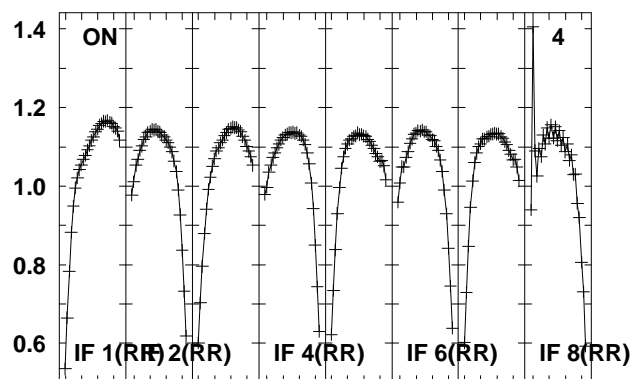
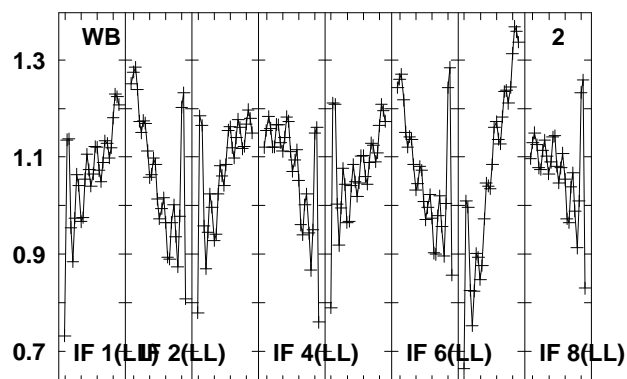
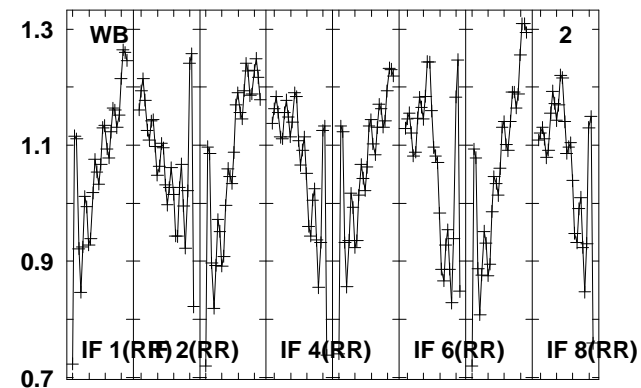
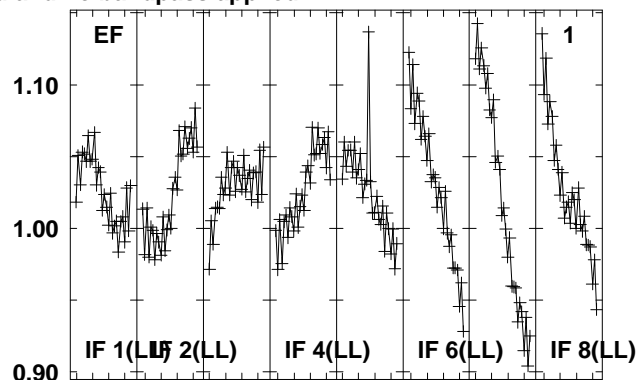
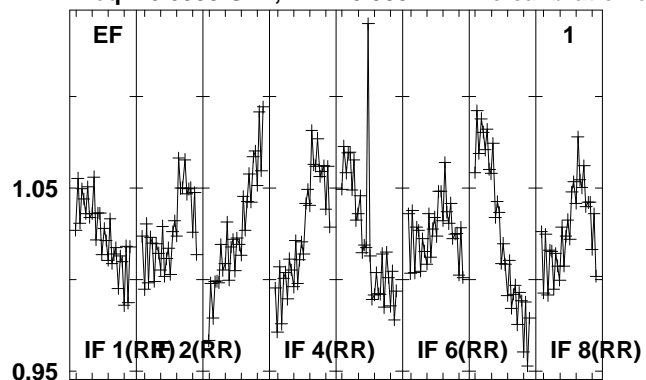

Lower frame: Real Jy
Total-power spectrum Antenna: *
Timerange: 00/12:37:55 to 00/12:39:23

Plot file version 124 created 15-MAR-2012 17:31:51

G85.40 EZ020E 2.UVDATA.1

Freq = 6.6335 GHz, Bw = 8.000 MH No calibration applied and no bandpass applied

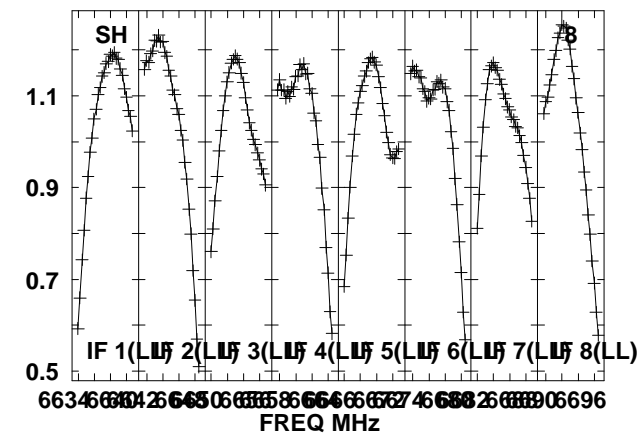
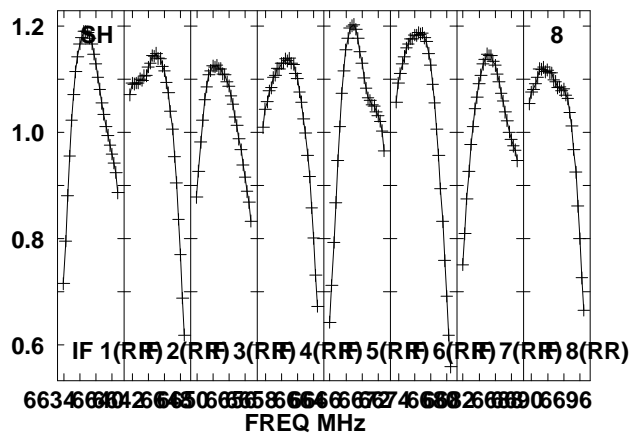
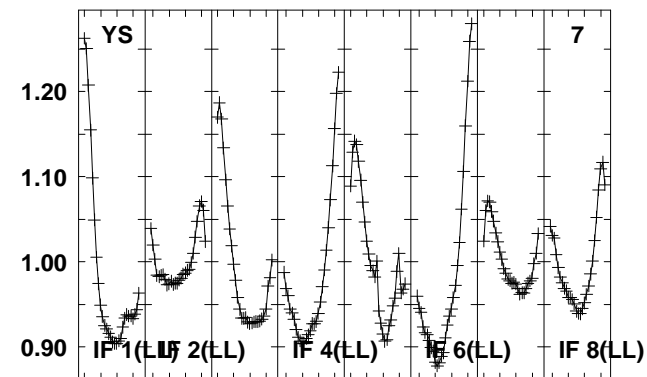
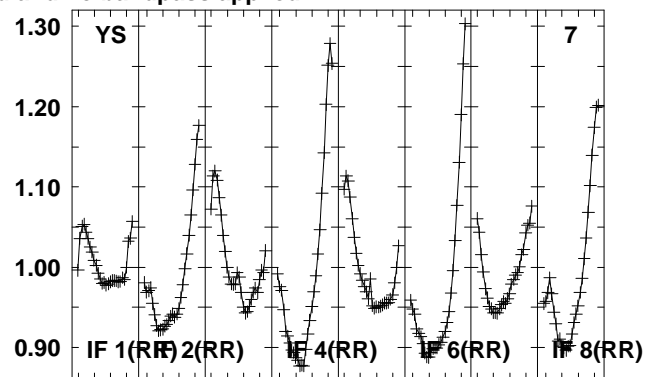
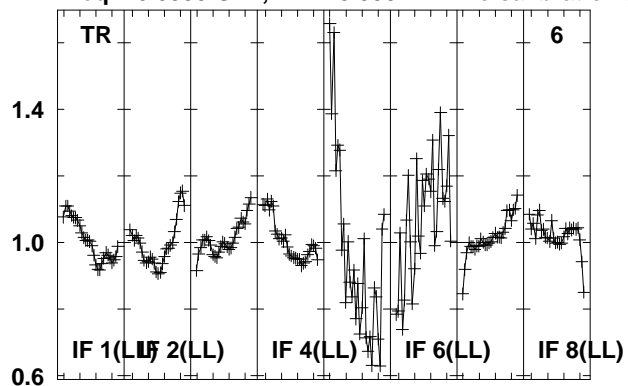

Lower frame: Real Jy
Total-power spectrum Antenna: *
Timerange: 00/12:37:55 to 00/12:39:23

Plot file version 125 created 15-MAR-2012 17:31:52
 2114-G85 EZ020E 2.UVDATA.1
 Freq = 6.6335 GHz, Bw = 8.000 MH No calibration applied and no bandpass applied

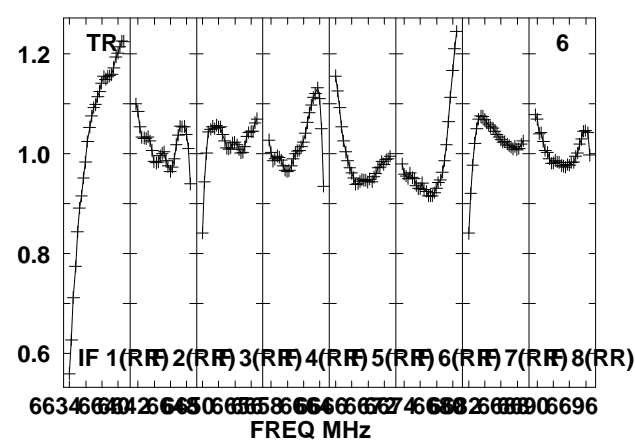
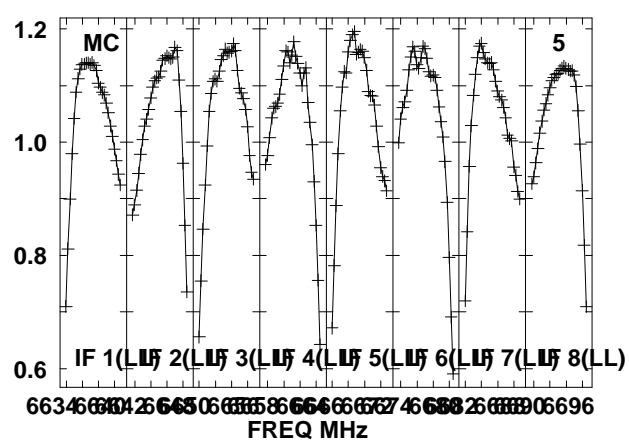
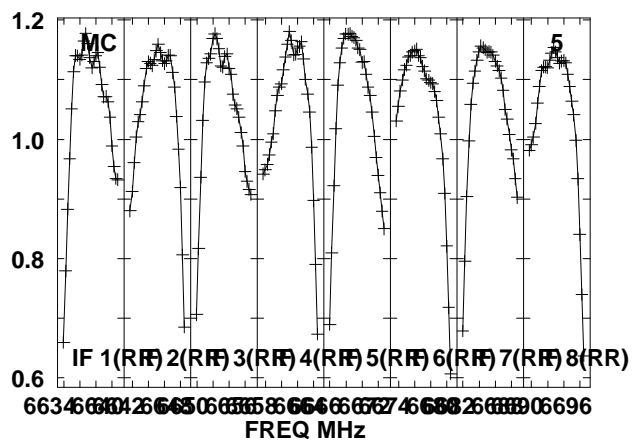
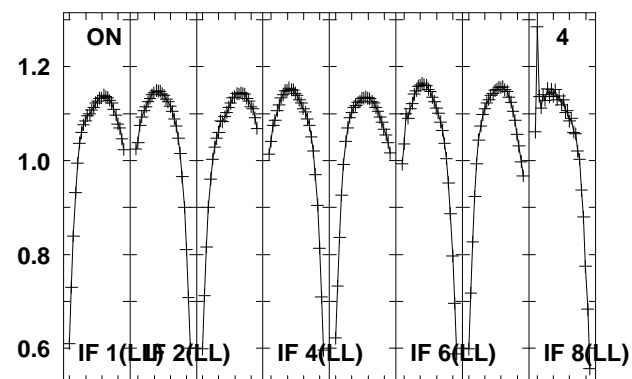
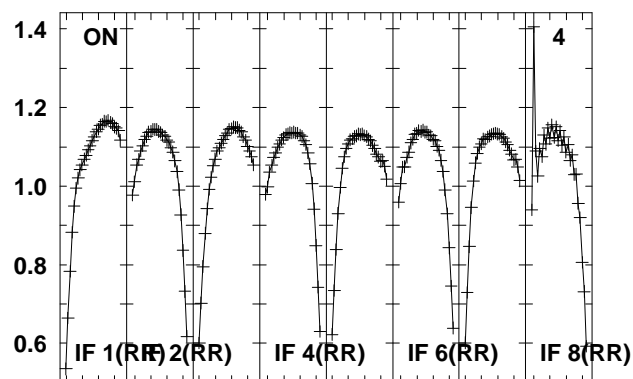
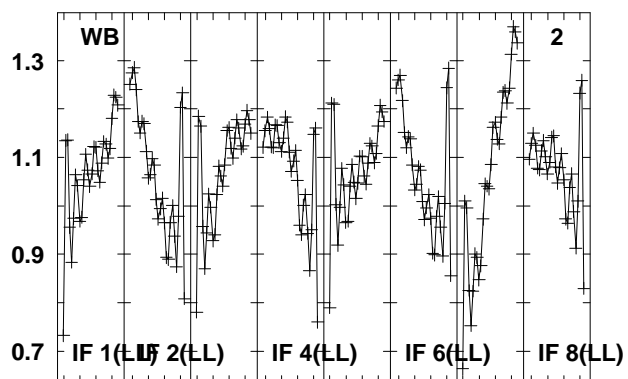
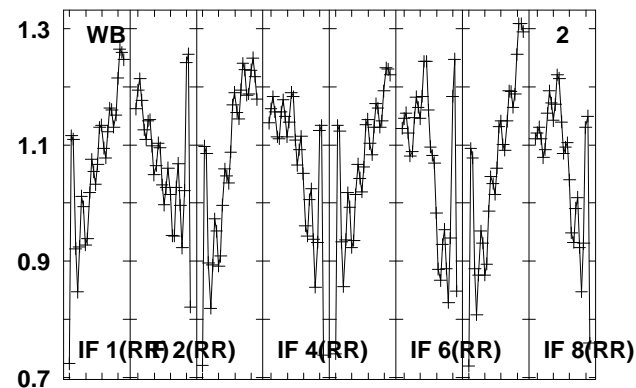
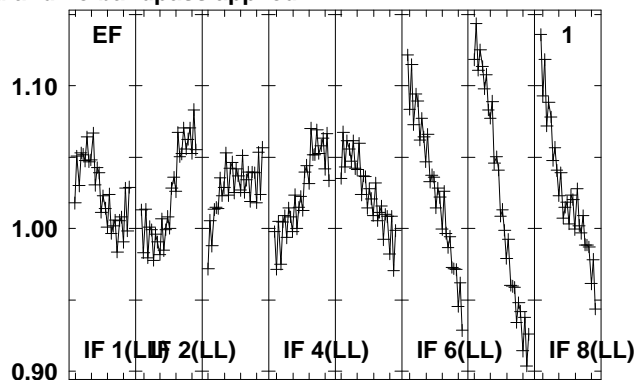
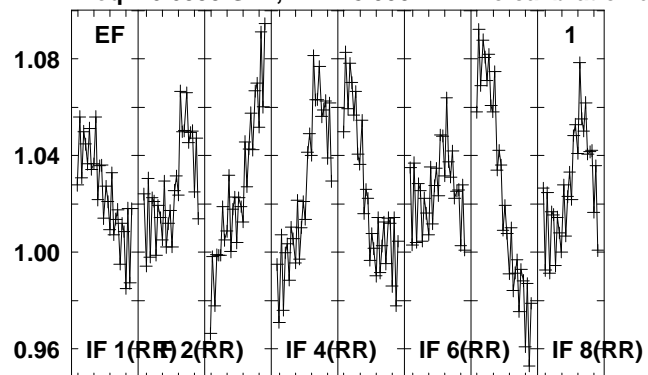

Lower frame: Real Jy
 Total-power spectrum Antenna: *
 Timerange: 00/12:39:25 to 00/12:40:53

Plot file version 126 created 15-MAR-2012 17:31:55

2114-G85 EZ020E 2.UVDATA.1

Freq = 6.6335 GHz, Bw = 8.000 MH No calibration applied and no bandpass applied

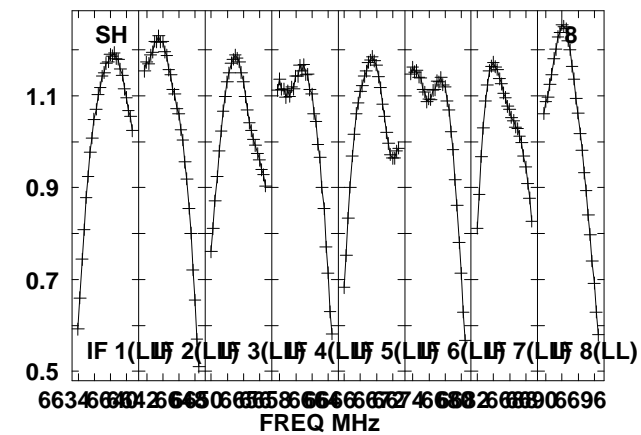
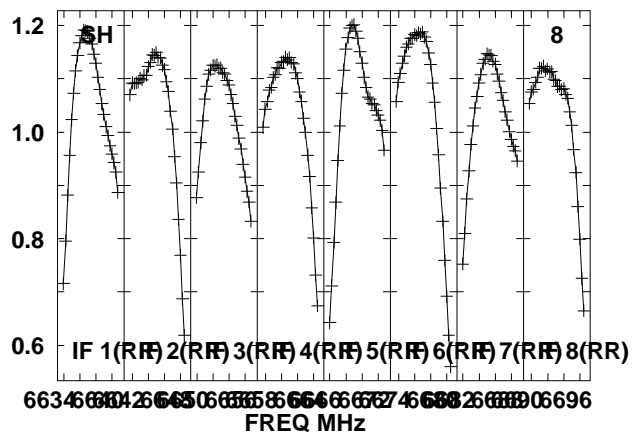
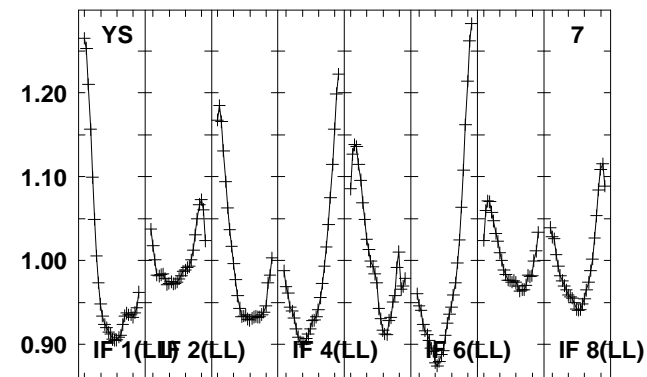
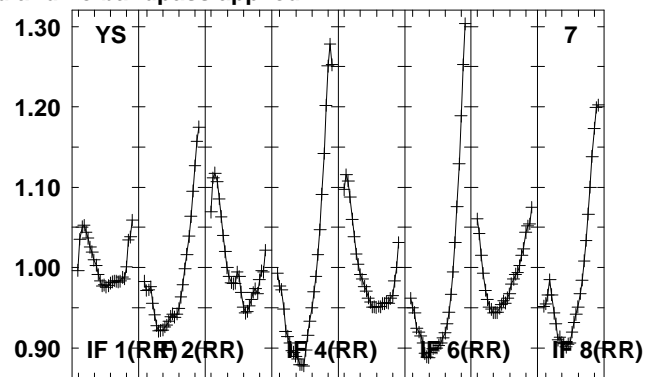
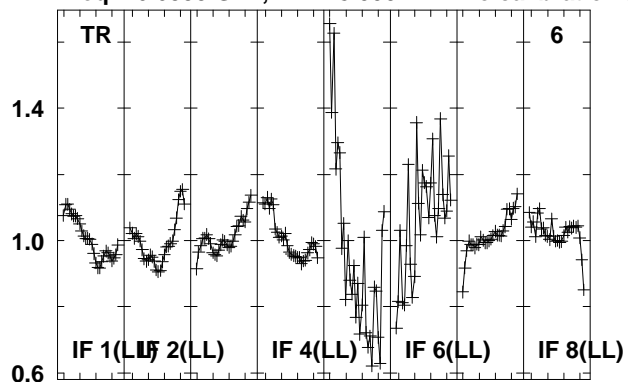

Lower frame: Real Jy
Total-power spectrum Antenna: *
Timerange: 00/12:39:25 to 00/12:40:53

Plot file version 127 created 15-MAR-2012 17:31:56

G85.40 EZ020E 2.UVDATA.1

Freq = 6.6335 GHz, Bw = 8.000 MH No calibration applied and no bandpass applied

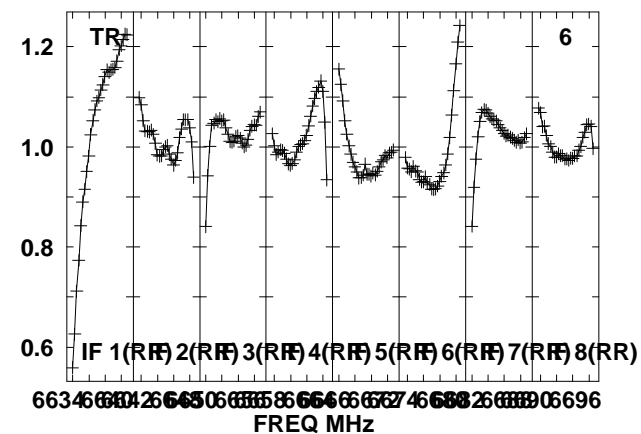
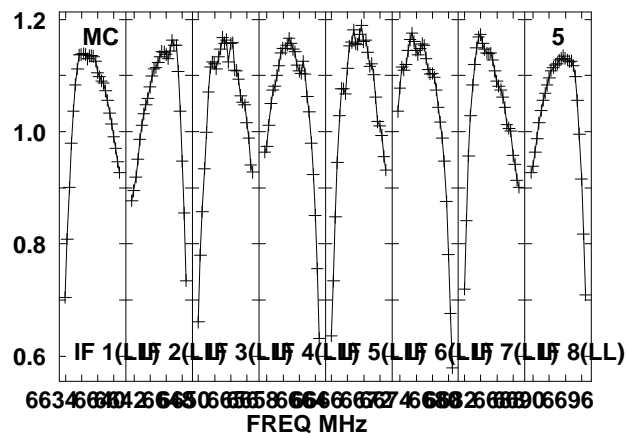
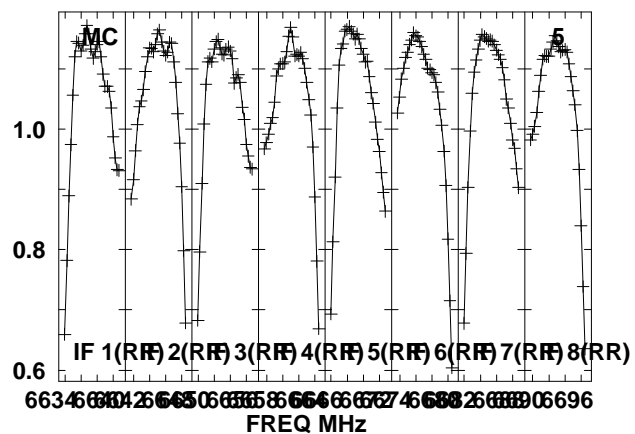
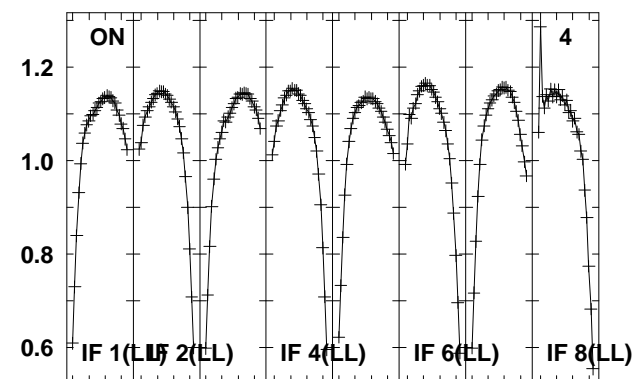
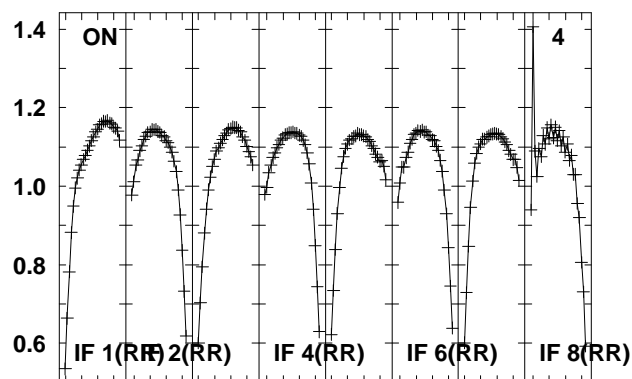
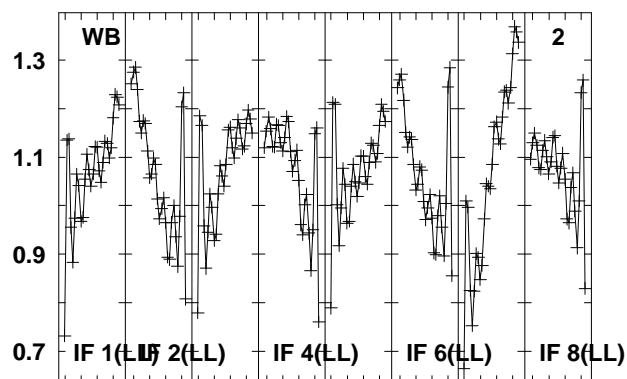
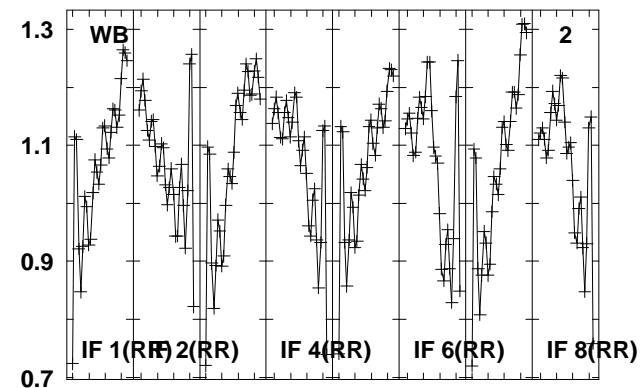
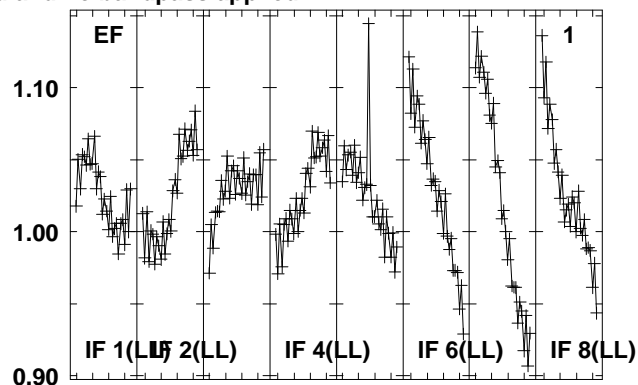
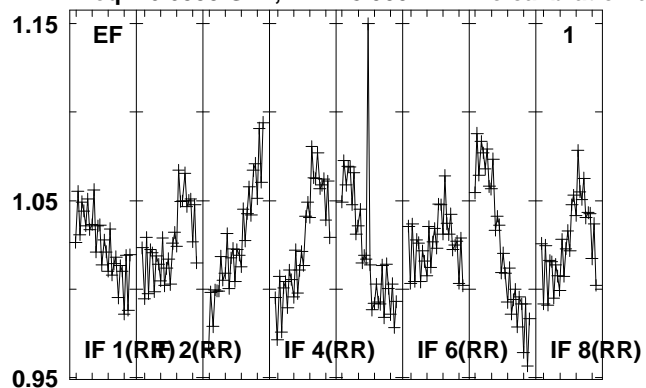

Lower frame: Real Jy

Total-power spectrum Antenna: *

Timerange: 00/12:41:35 to 00/12:42:32

Plot file version 128 created 15-MAR-2012 17:31:56

G85.40 EZ020E 2.UVDATA.1

Freq = 6.6335 GHz, Bw = 8.000 MH No calibration applied and no bandpass applied

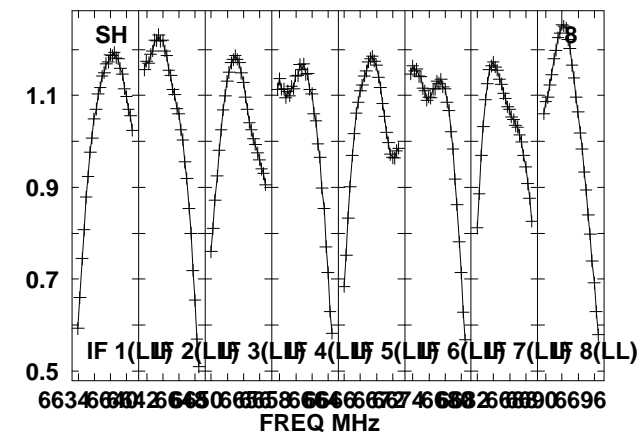
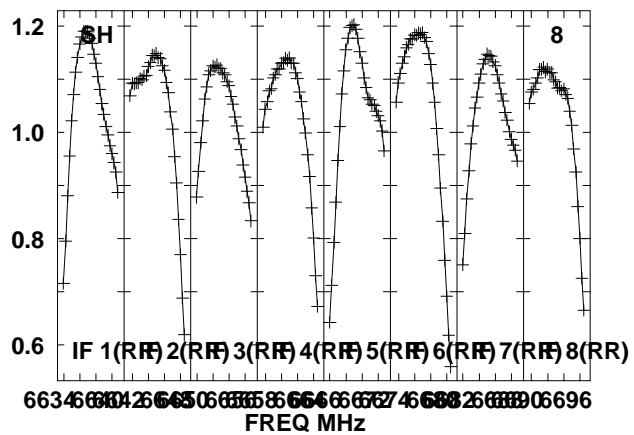
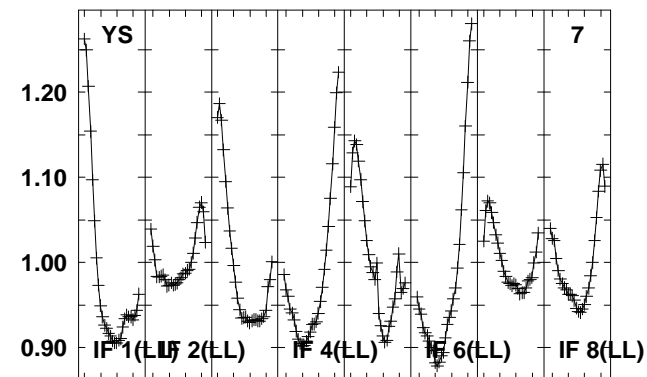
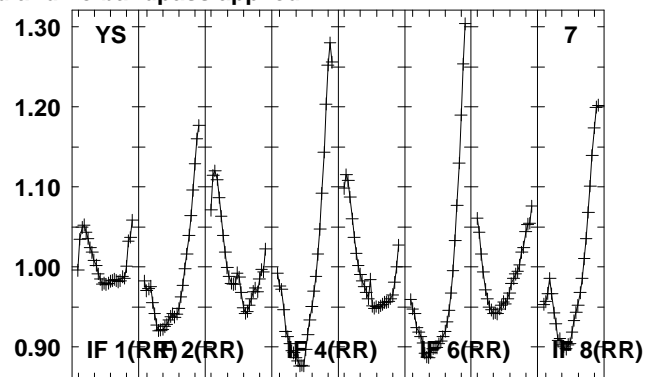
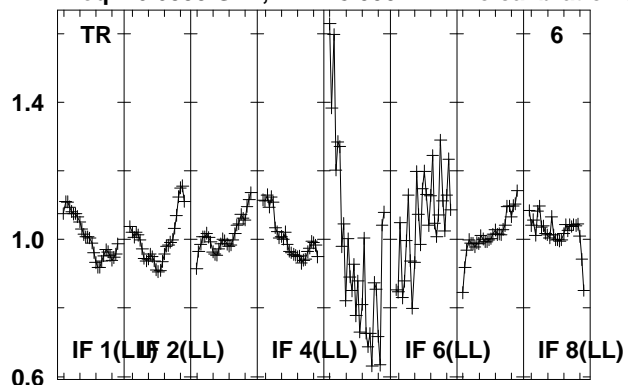

Lower frame: Real Jy
Total-power spectrum Antenna: *
Timerange: 00/12:41:35 to 00/12:42:32

Plot file version 129 created 15-MAR-2012 17:31:57
 J1800G85 EZ020E 2.UVDATA.1
 Freq = 6.6335 GHz, Bw = 8.000 MH No calibration applied and no bandpass applied

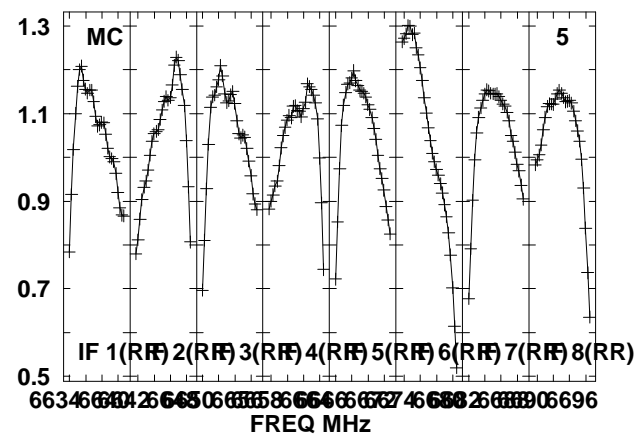
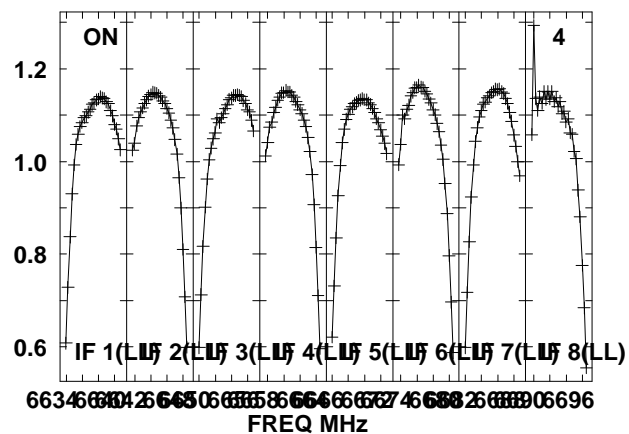
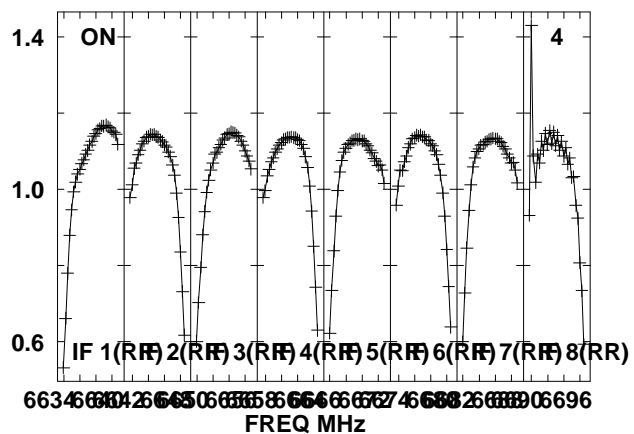
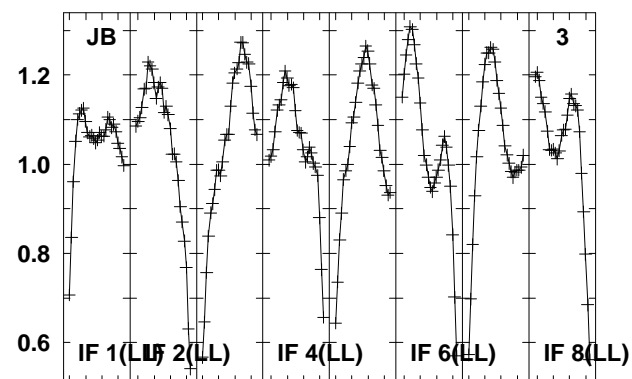
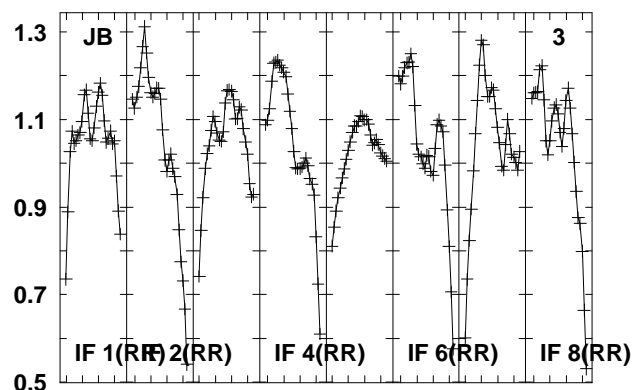
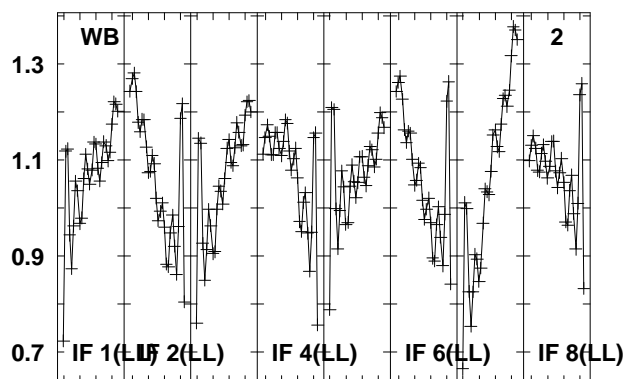
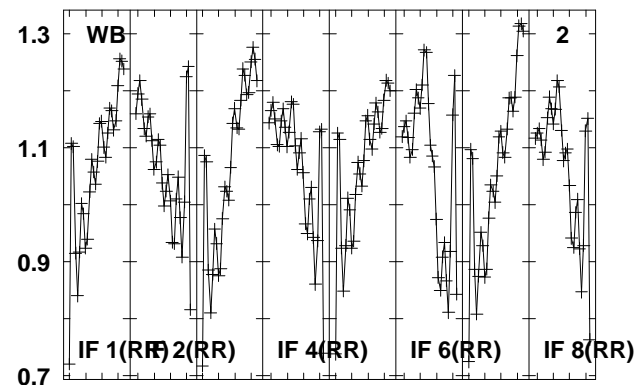
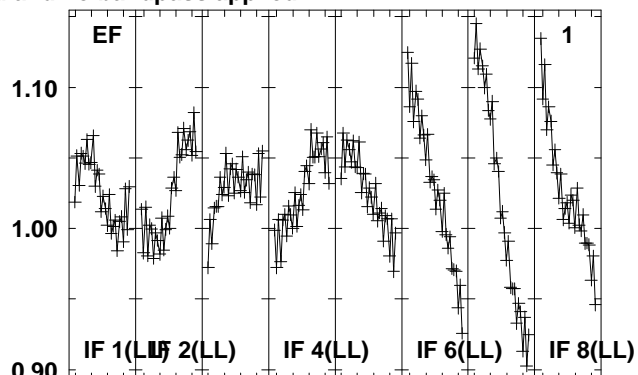
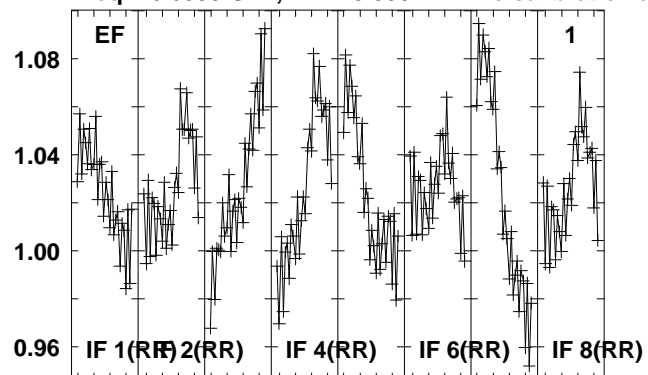

Lower frame: Real Jy
 Total-power spectrum Antenna: *
 Timerange: 00/13:21:47 to 00/13:24:45

Plot file version 130 created 15-MAR-2012 17:31:57

J1800G85 EZ020E 2.UVDATA.1

Freq = 6.6335 GHz, Bw = 8.000 MH No calibration applied and no bandpass applied

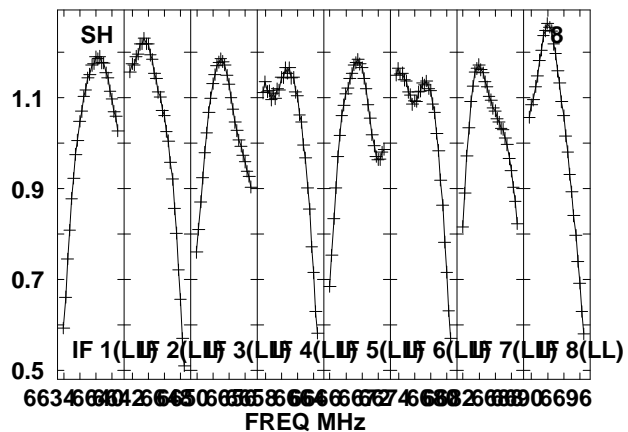
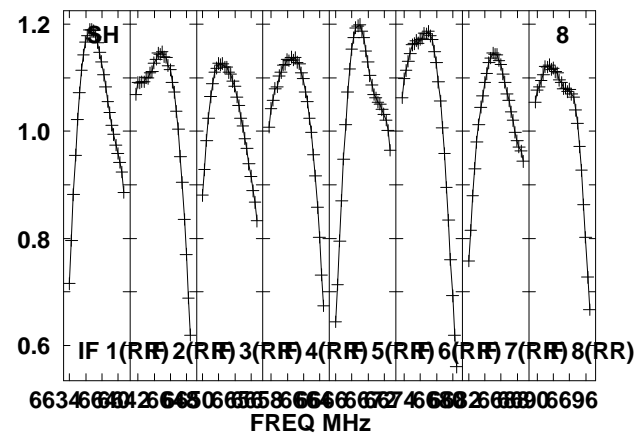
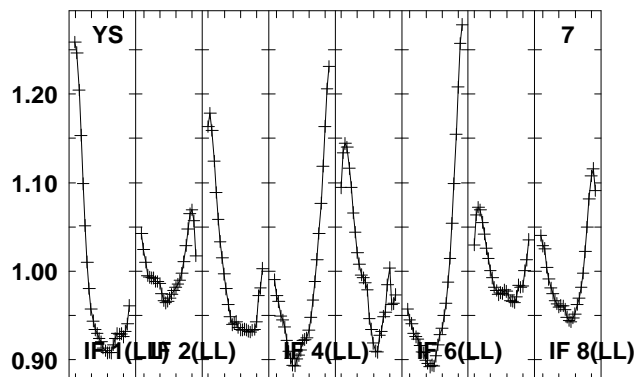
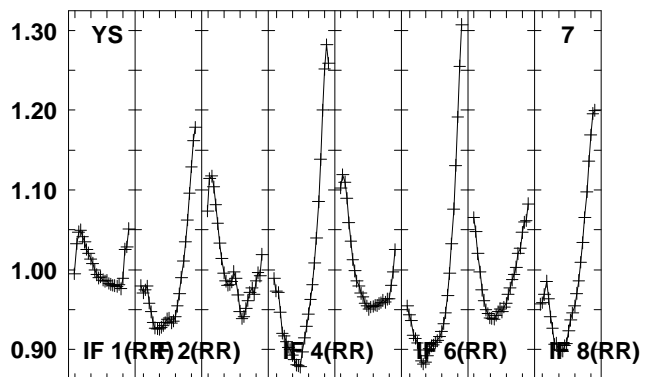
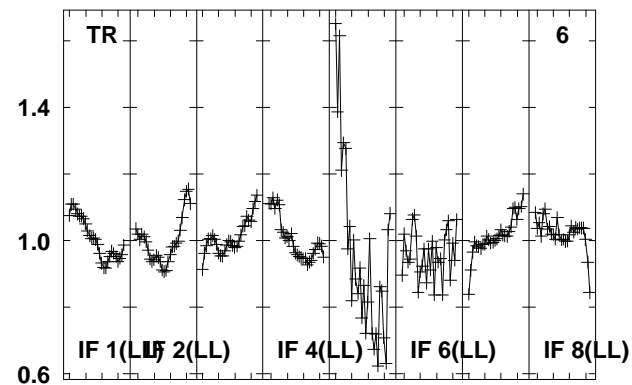
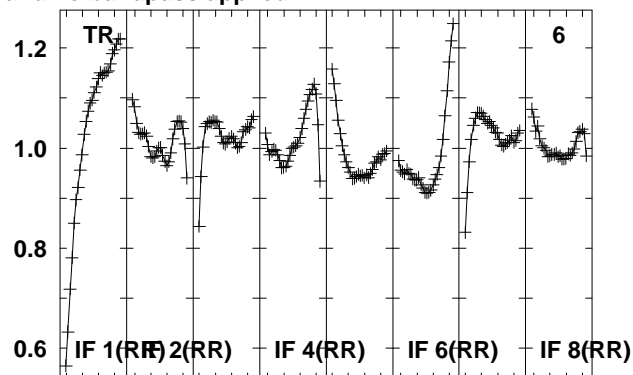
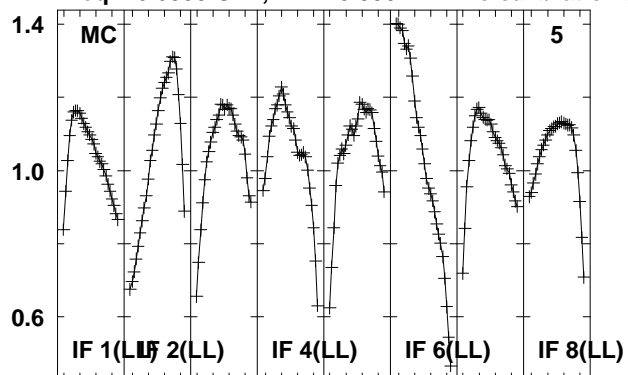

Lower frame: Real Jy

Total-power spectrum Antenna: *

Timerange: 00/13:21:47 to 00/13:24:45

Plot file version 131 created 15-MAR-2012 17:31:59

G85.40 EZ020E 2.UVDATA.1

Freq = 6.6335 GHz, Bw = 8.000 MH No calibration applied and no bandpass applied

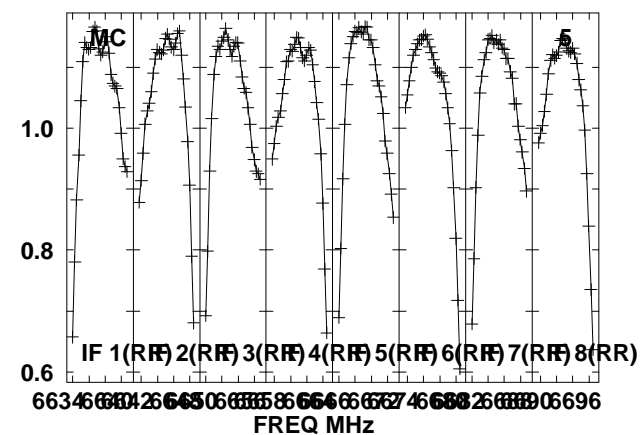
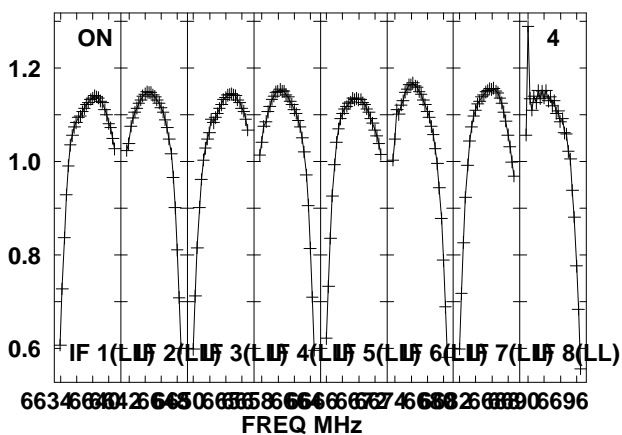
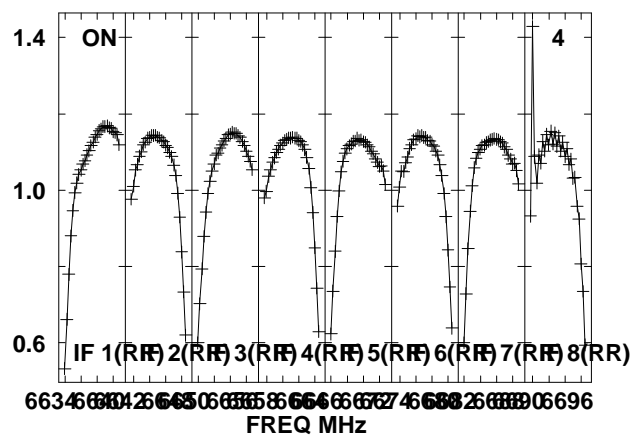
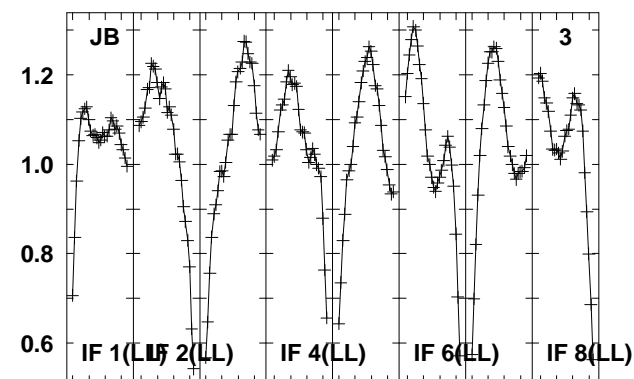
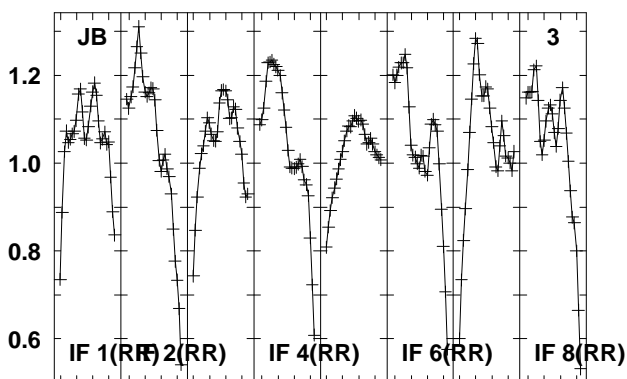
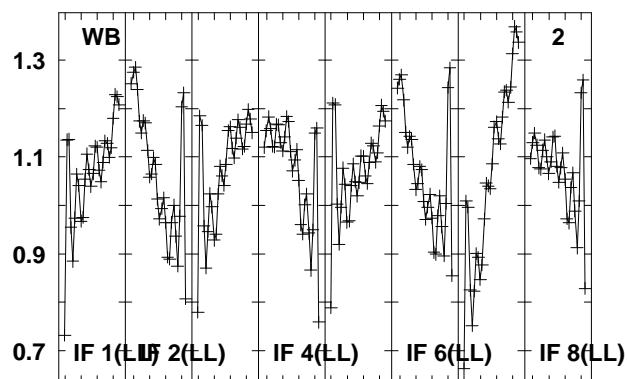
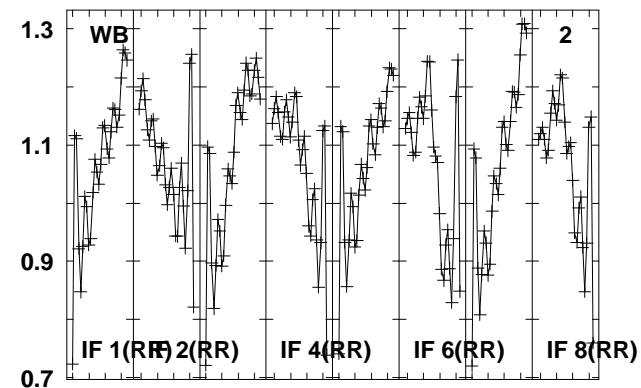
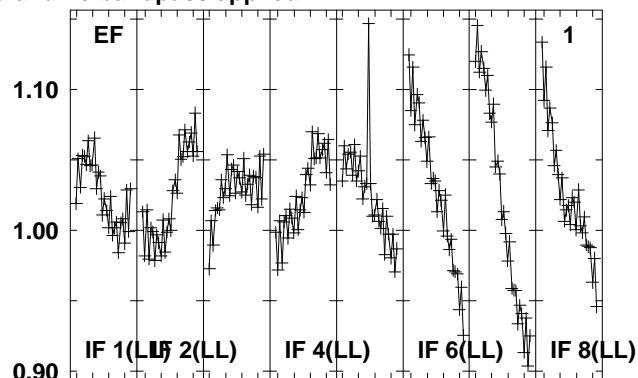
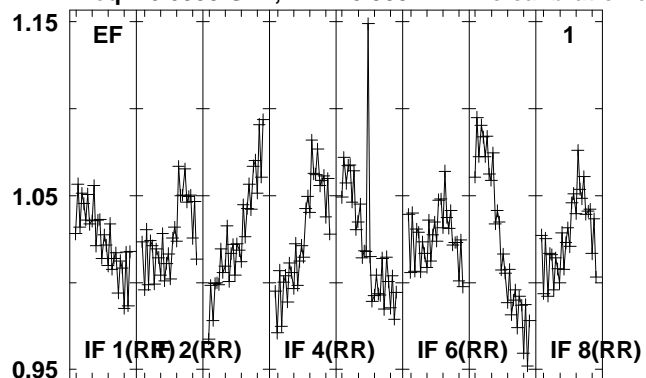

Lower frame: Real Jy
Total-power spectrum Antenna: *
Timerange: 00/13:27:23 to 00/13:28:20

Plot file version 132 created 15-MAR-2012 17:32:00

G85.40 EZ020E 2.UVDATA.1

Freq = 6.6335 GHz, Bw = 8.000 MH No calibration applied and no bandpass applied

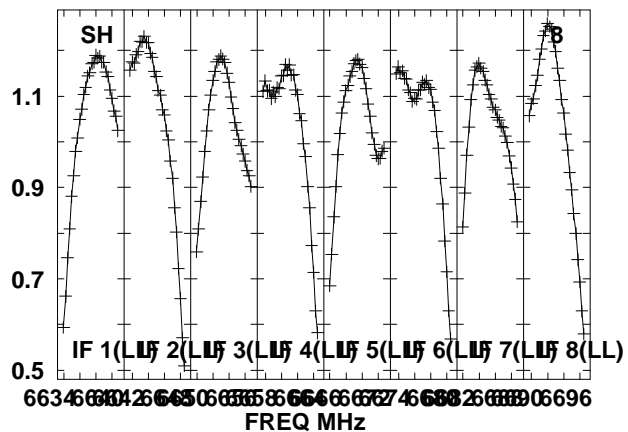
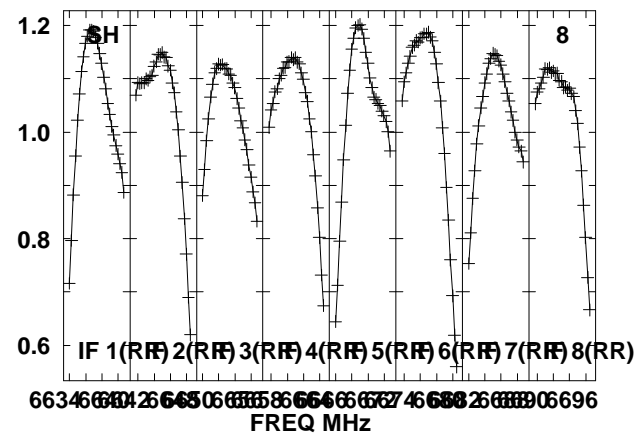
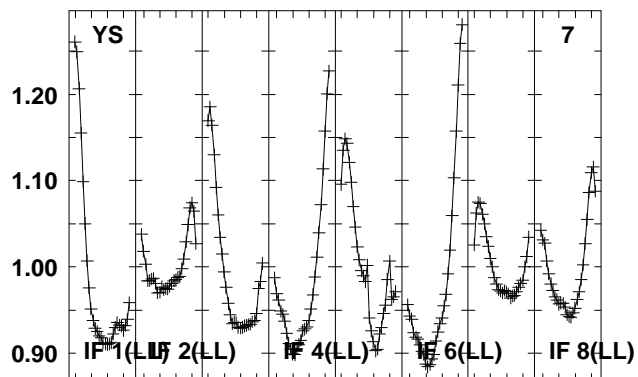
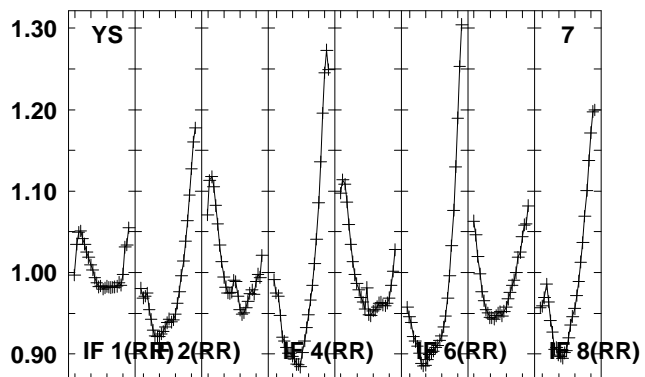
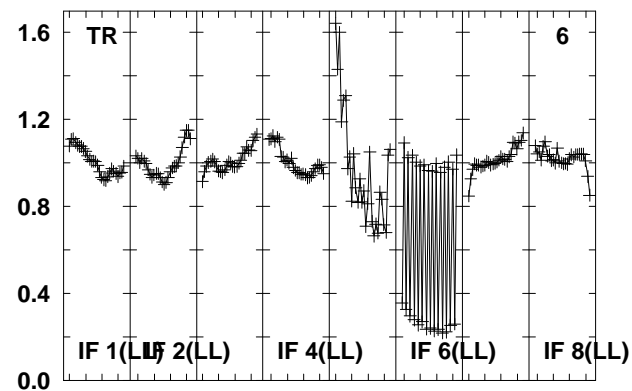
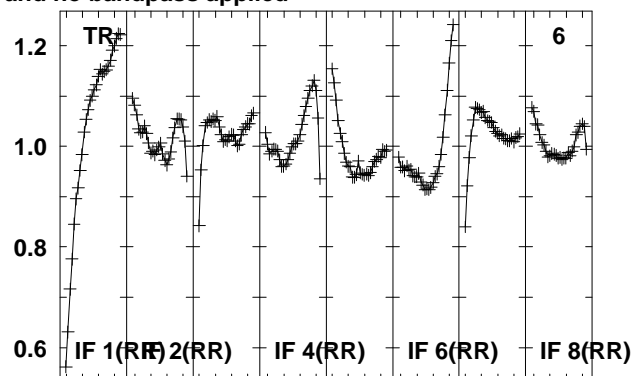
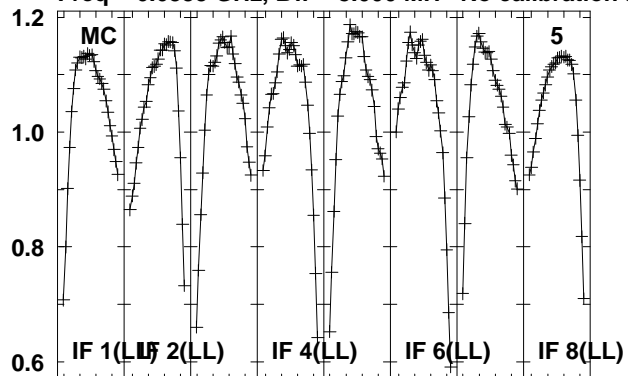

Lower frame: Real Jy

Total-power spectrum Antenna: *

Timerange: 00/13:27:23 to 00/13:28:20

Plot file version 133 created 15-MAR-2012 17:32:00
 2102-G85 EZ020E 2.UVDATA.1
 Freq = 6.6335 GHz, Bw = 8.000 MH No calibration applied and no bandpass applied

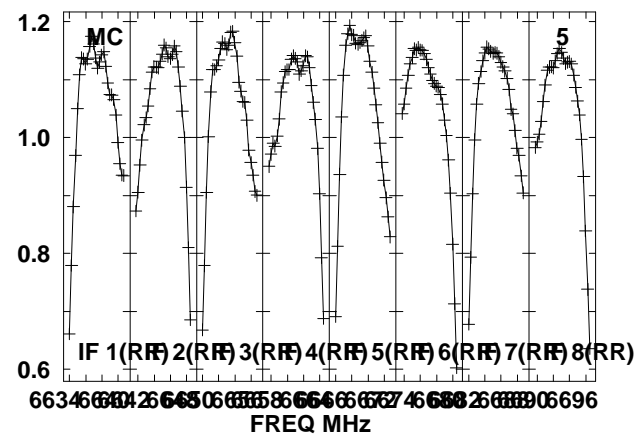
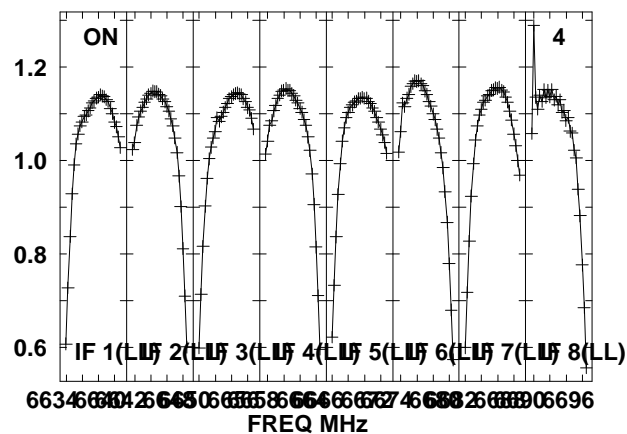
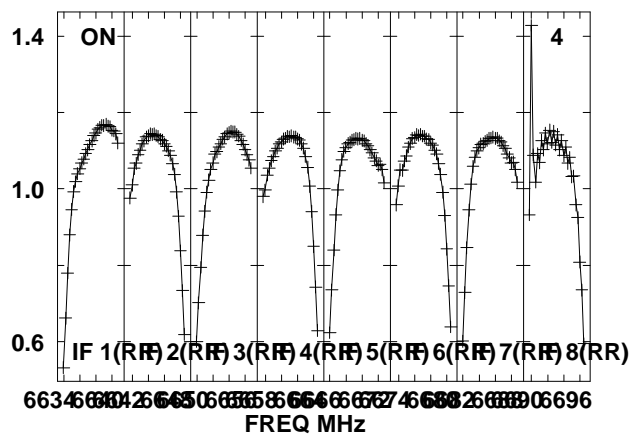
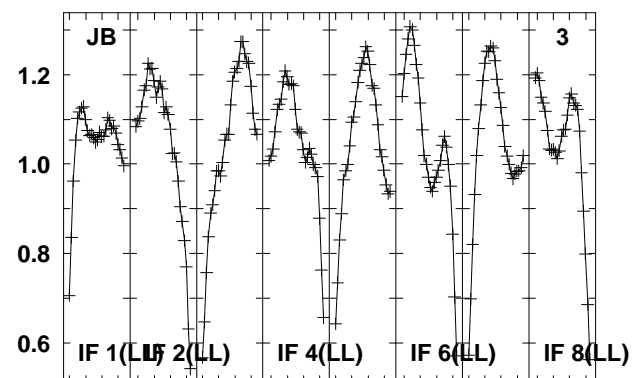
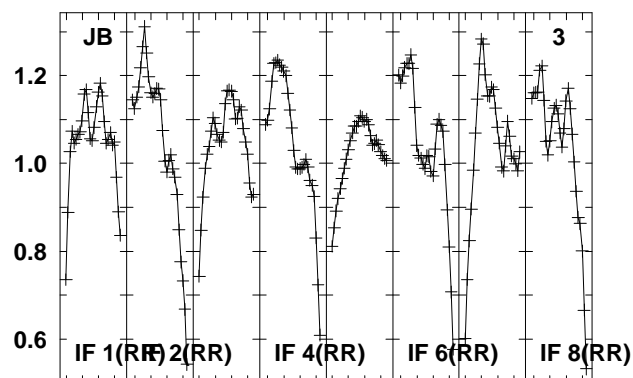
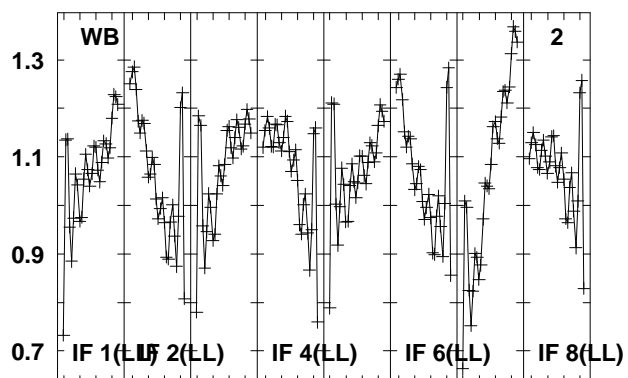
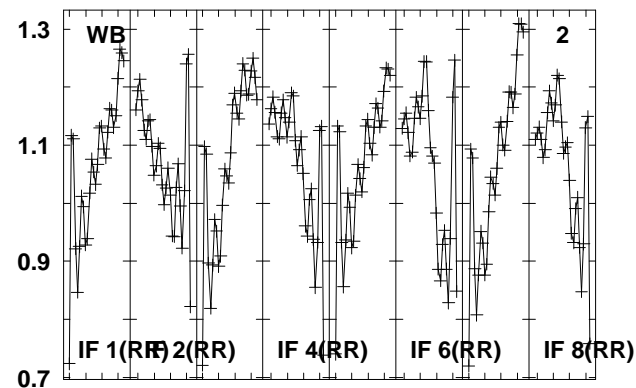
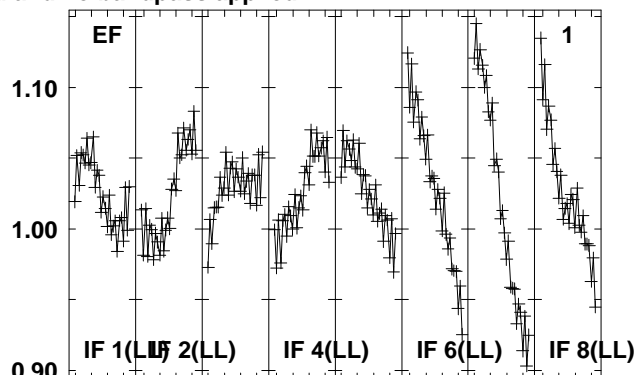
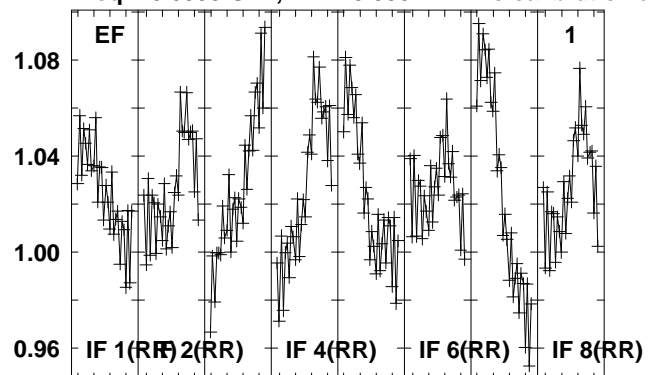

Lower frame: Real Jy
 Total-power spectrum Antenna: *
 Timerange: 00/13:28:22 to 00/13:29:50

Plot file version 134 created 15-MAR-2012 17:32:01

2102-G85 EZ020E 2.UVDATA.1

Freq = 6.6335 GHz, Bw = 8.000 MH No calibration applied and no bandpass applied

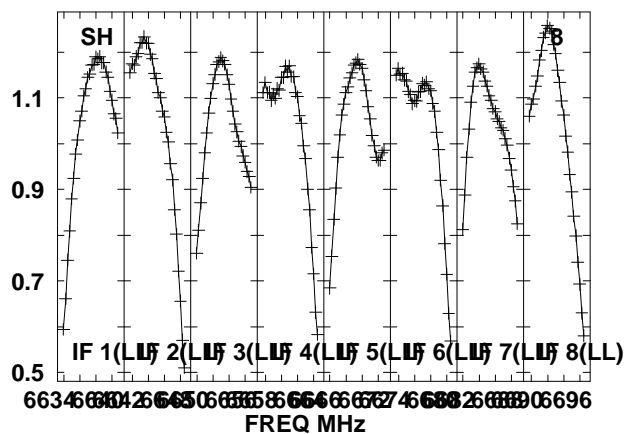
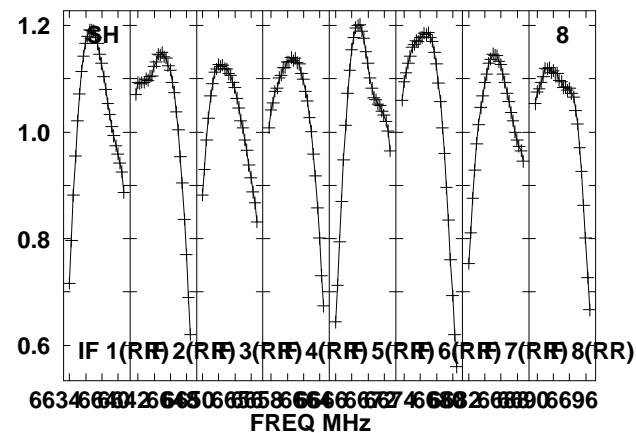
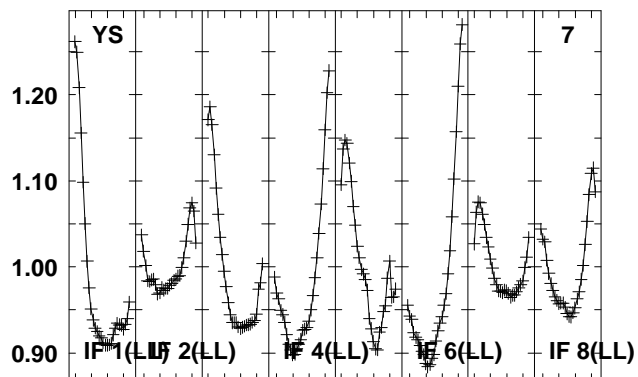
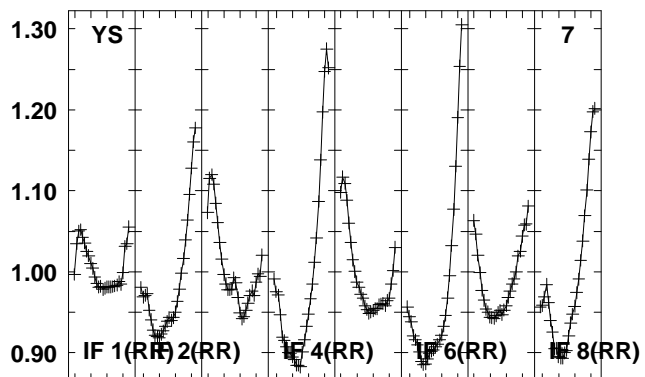
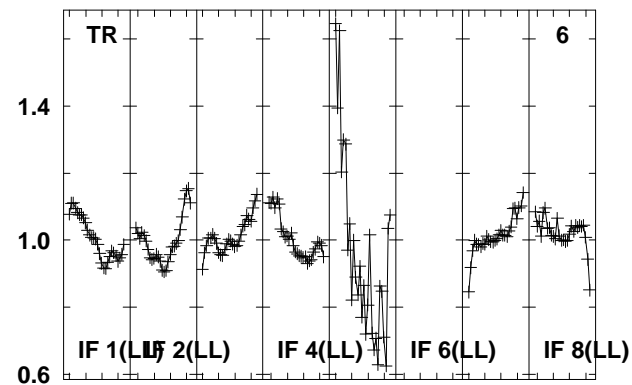
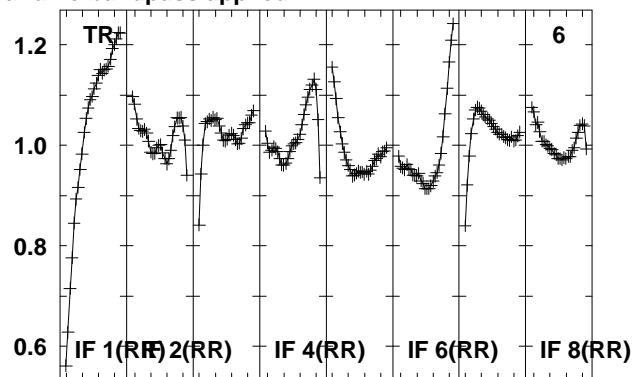
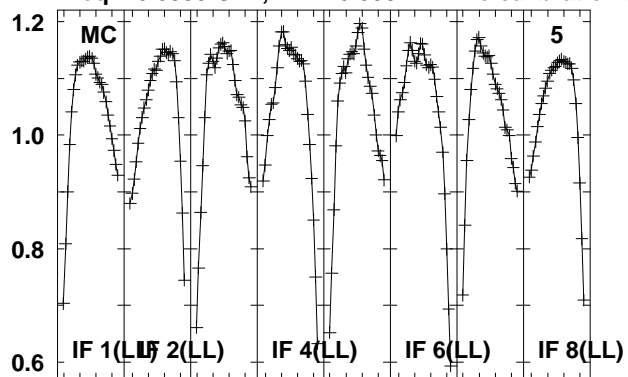

Lower frame: Real Jy

Total-power spectrum Antenna: *

Timerange: 00/13:28:22 to 00/13:29:50

Plot file version 135 created 15-MAR-2012 17:32:01

G85.40 EZ020E 2.UVDATA.1

Freq = 6.6335 GHz, Bw = 8.000 MH No calibration applied and no bandpass applied

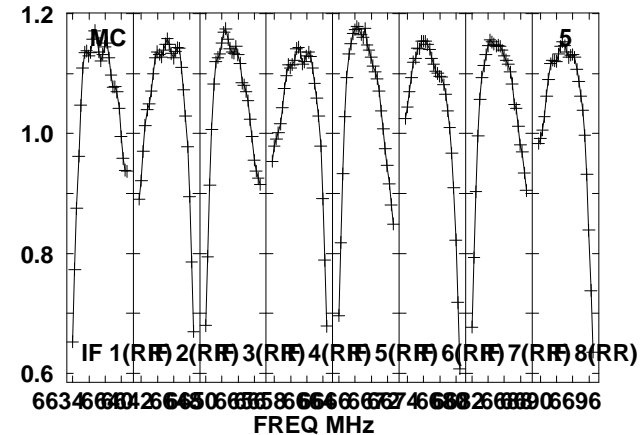
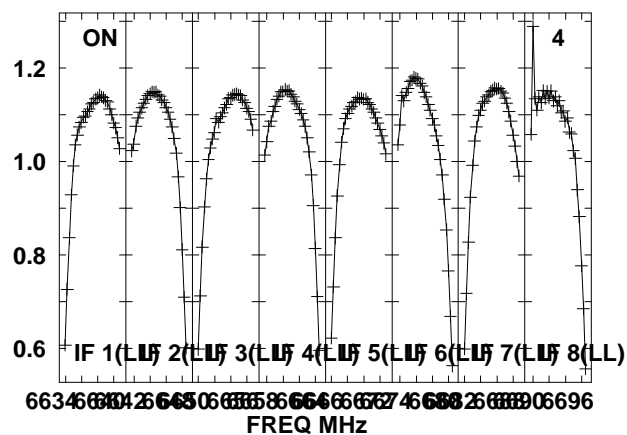
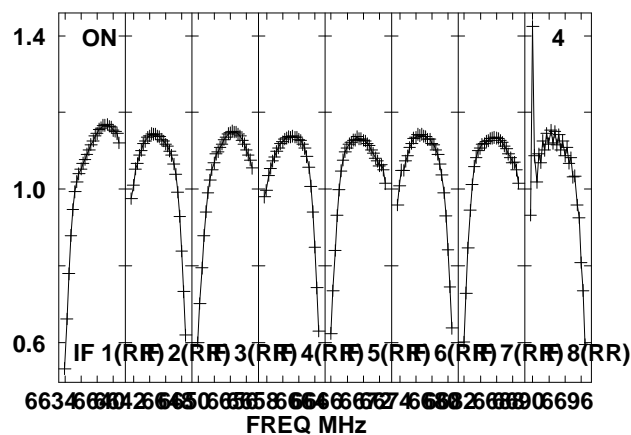
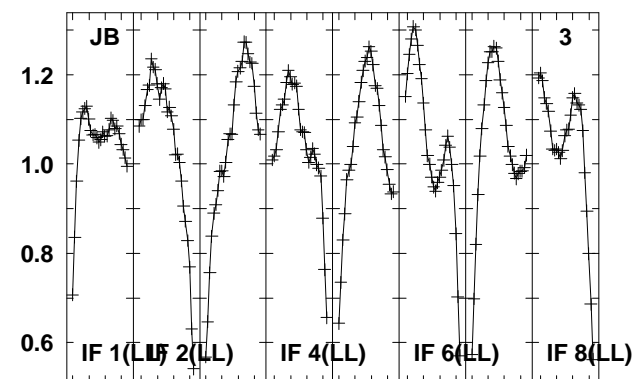
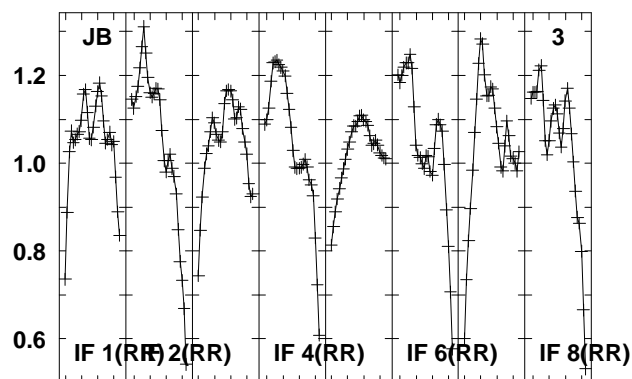
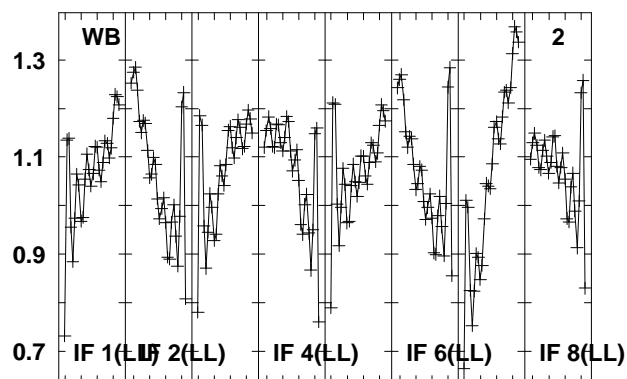
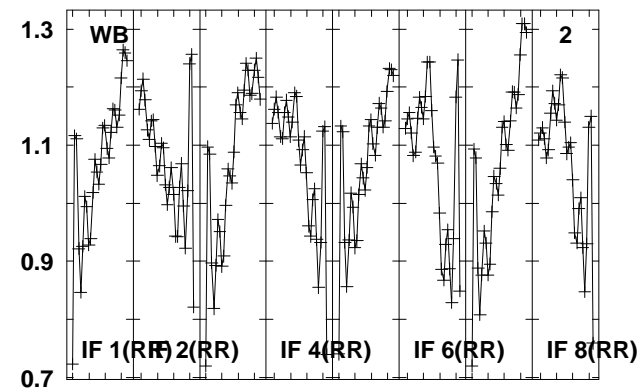
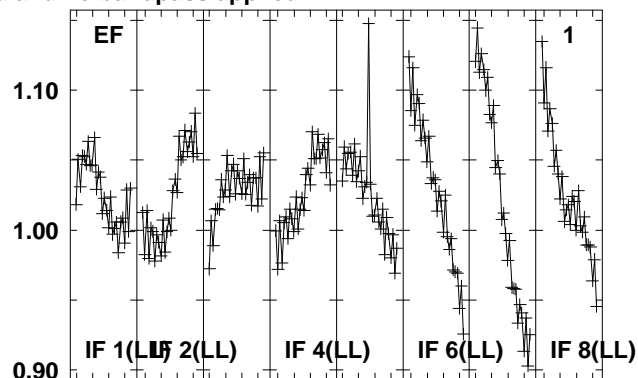
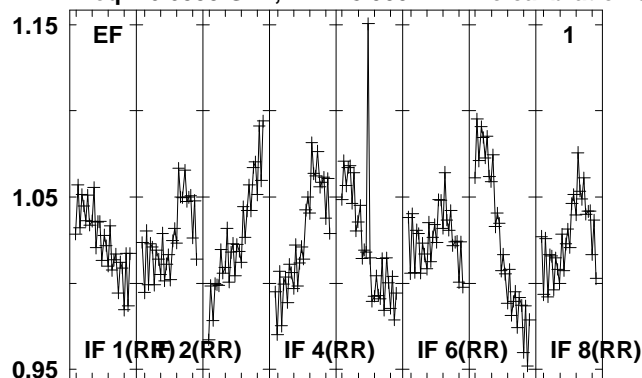

Lower frame: Real Jy
Total-power spectrum Antenna: *
Timerange: 00/13:29:53 to 00/13:31:21

Plot file version 136 created 15-MAR-2012 17:32:02

G85.40 EZ020E 2.UVDATA.1

Freq = 6.6335 GHz, Bw = 8.000 MH No calibration applied and no bandpass applied

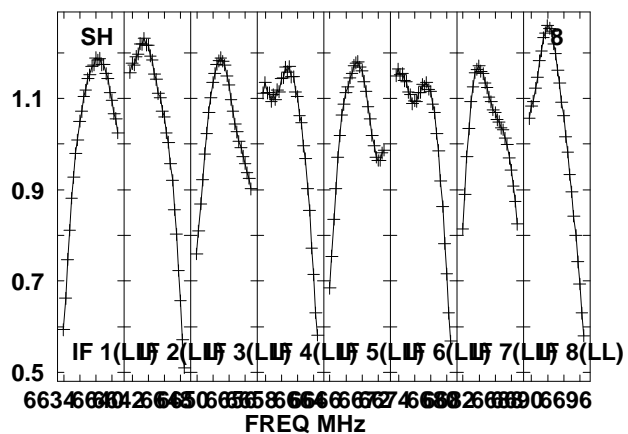
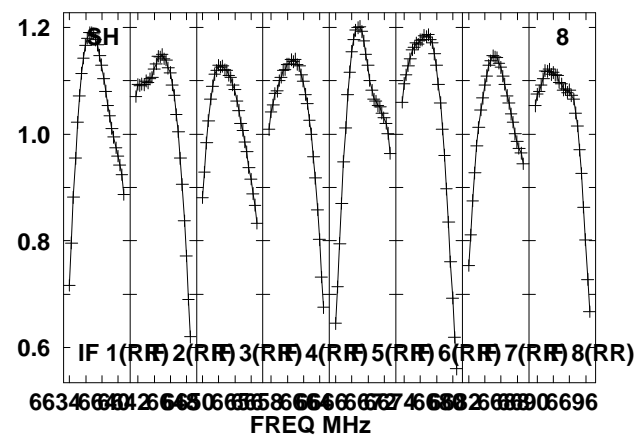
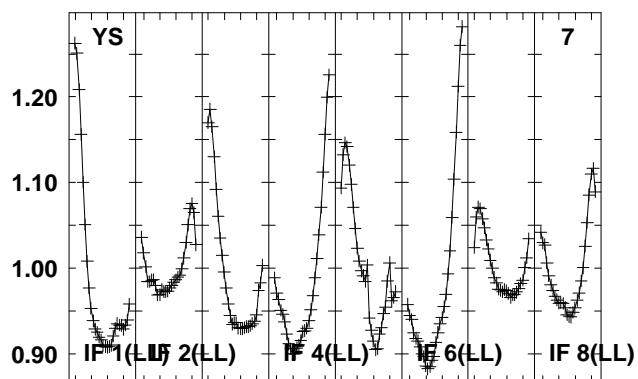
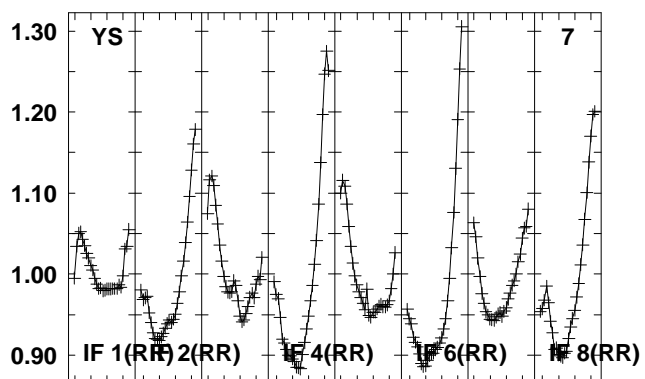
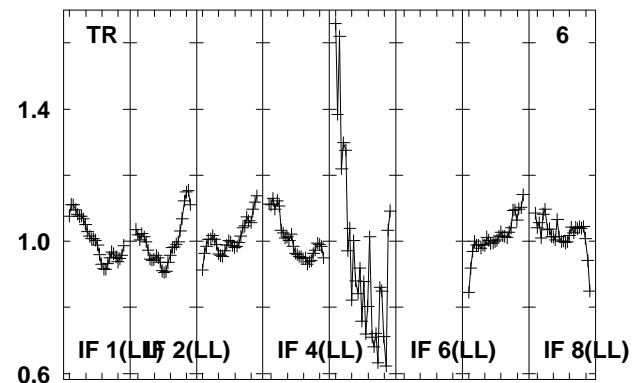
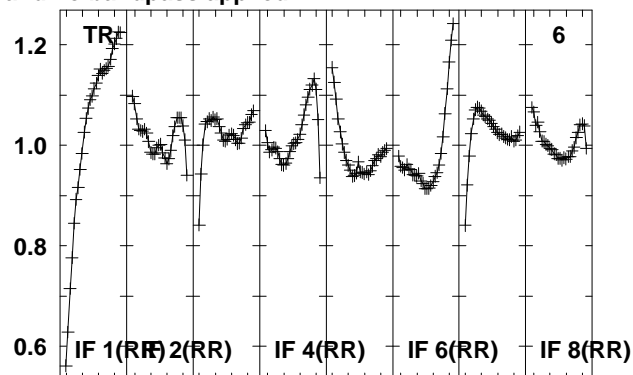
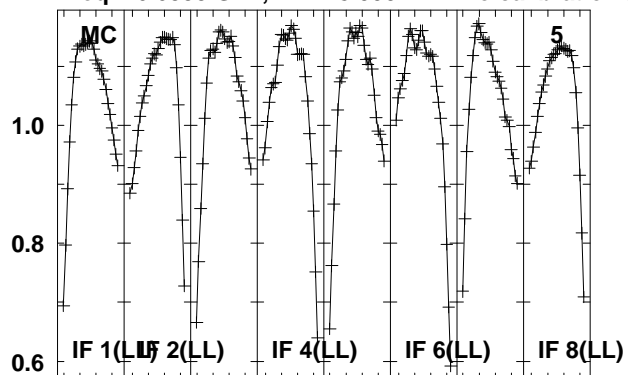

Lower frame: Real Jy

Total-power spectrum Antenna: *

Timerange: 00/13:29:53 to 00/13:31:21

Plot file version 137 created 15-MAR-2012 17:32:03
 2114-G85 EZ020E 2.UVDATA.1
 Freq = 6.6335 GHz, Bw = 8.000 MH No calibration applied and no bandpass applied

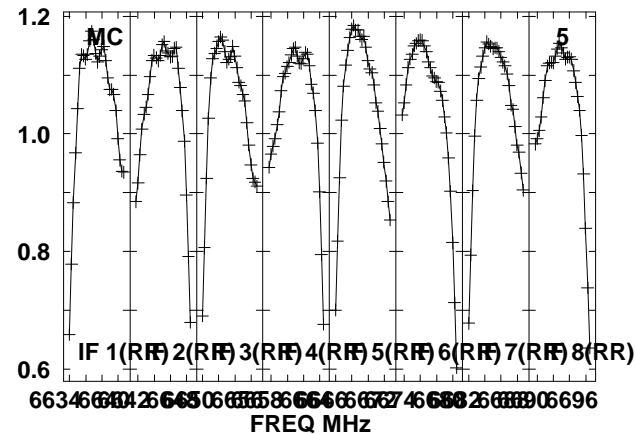
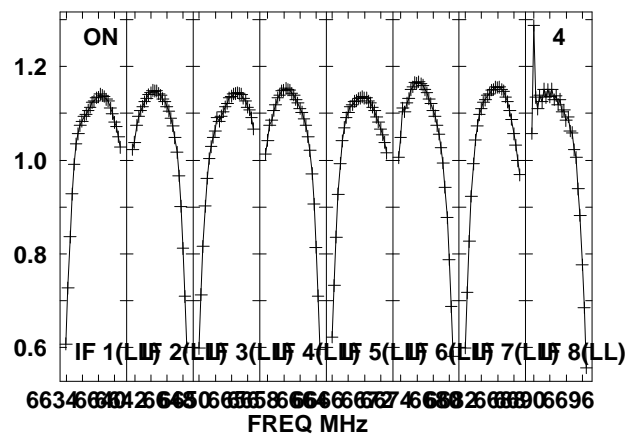
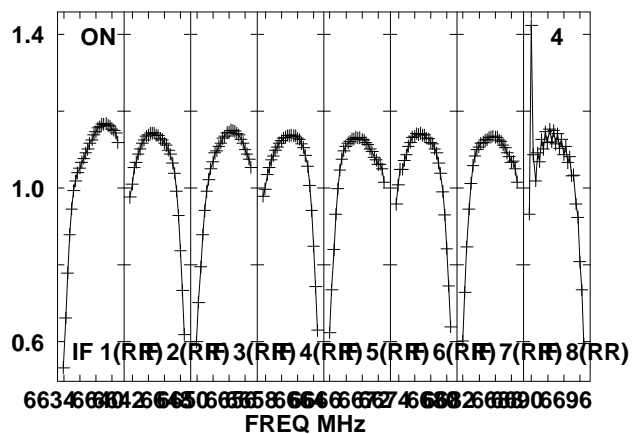
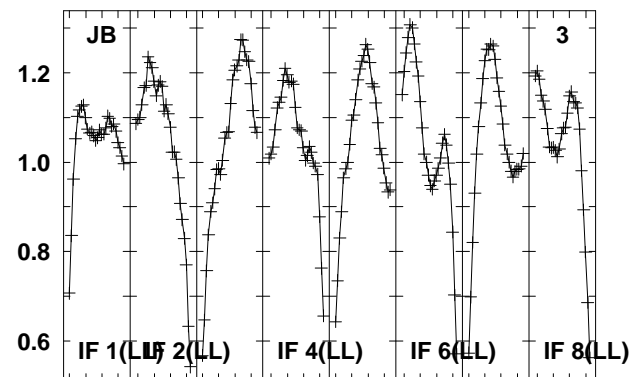
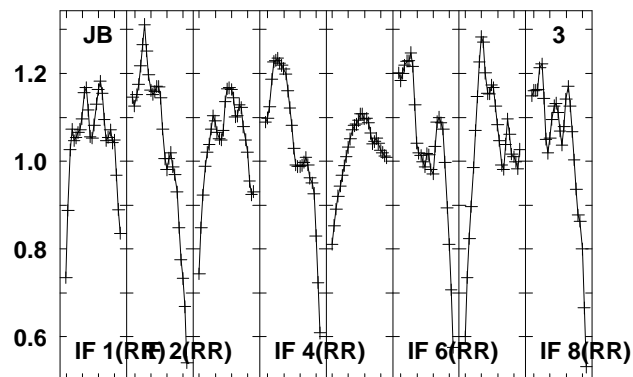
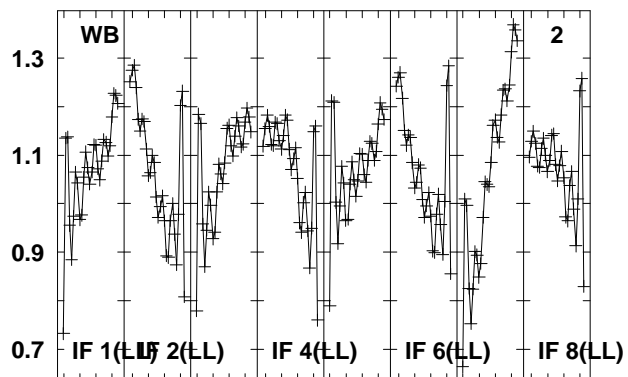
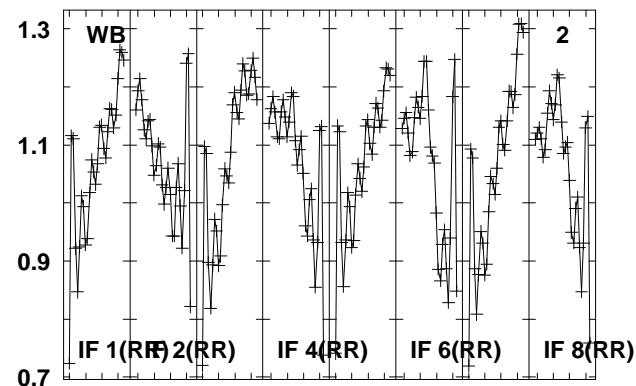
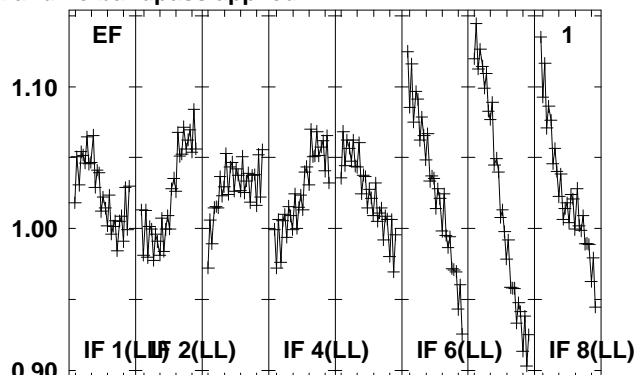
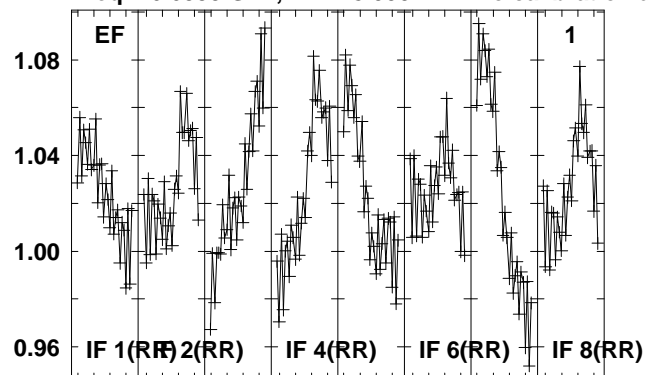

Lower frame: Real Jy
 Total-power spectrum Antenna: *
 Timerange: 00/13:31:23 to 00/13:32:51

Plot file version 138 created 15-MAR-2012 17:32:03

2114-G85 EZ020E 2.UVDATA.1

Freq = 6.6335 GHz, Bw = 8.000 MH No calibration applied and no bandpass applied

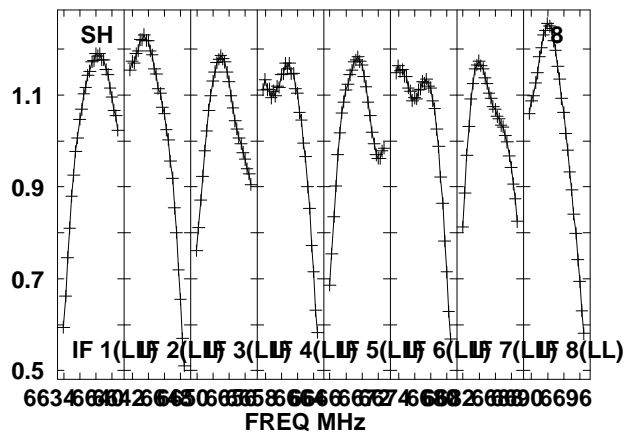
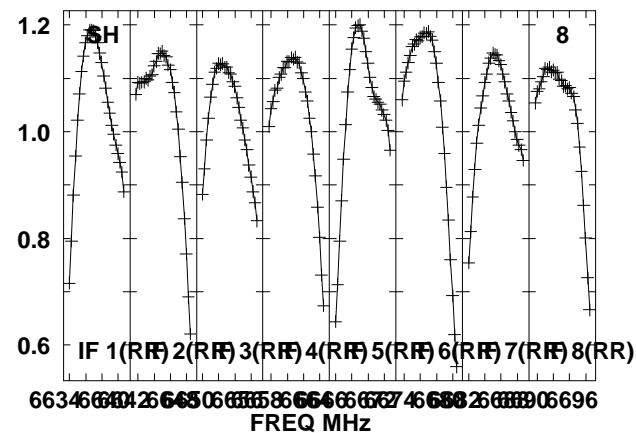
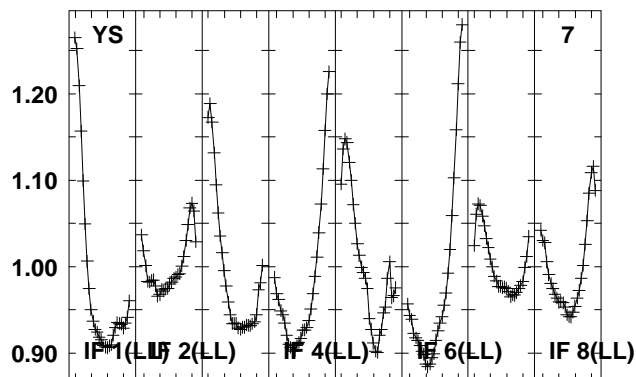
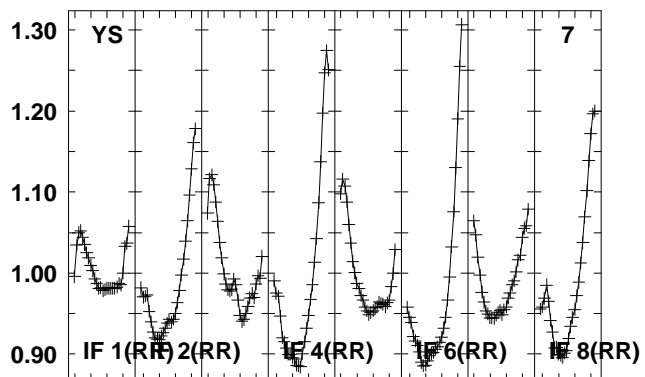
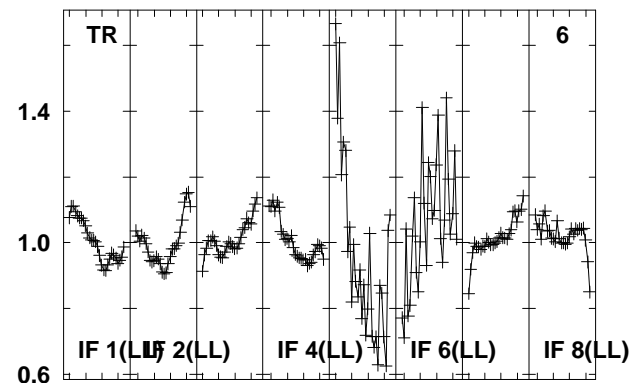
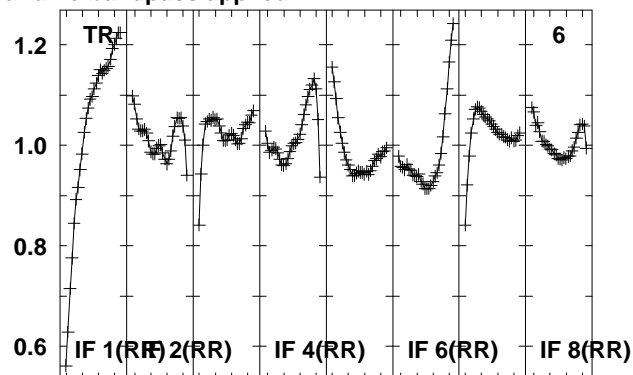
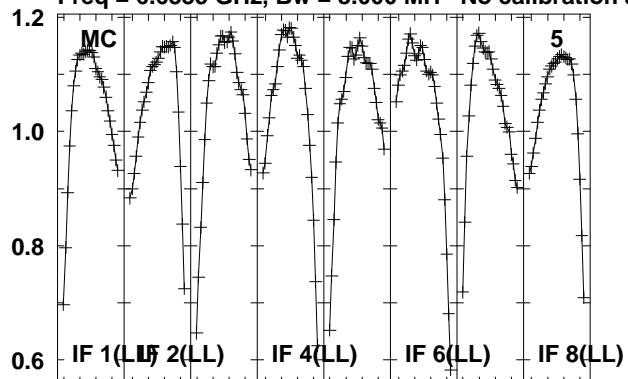

Lower frame: Real Jy

Total-power spectrum Antenna: *

Timerange: 00/13:31:23 to 00/13:32:51

Plot file version 139 created 15-MAR-2012 17:32:04

G85.40 EZ020E 2.UVDATA.1

Freq = 6.6335 GHz, Bw = 8.000 MH No calibration applied and no bandpass applied

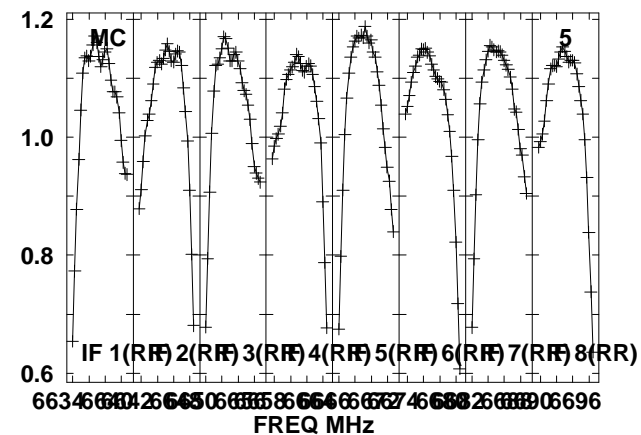
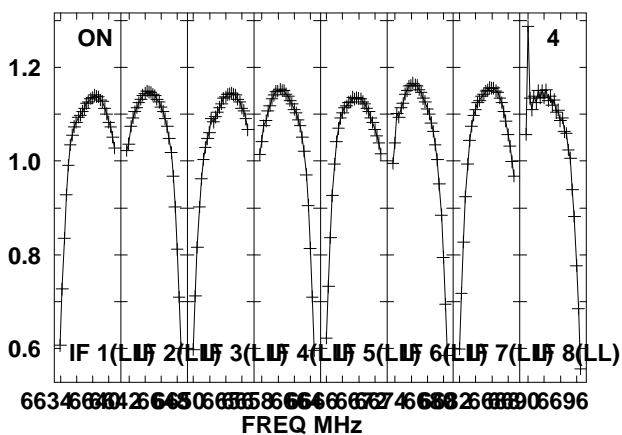
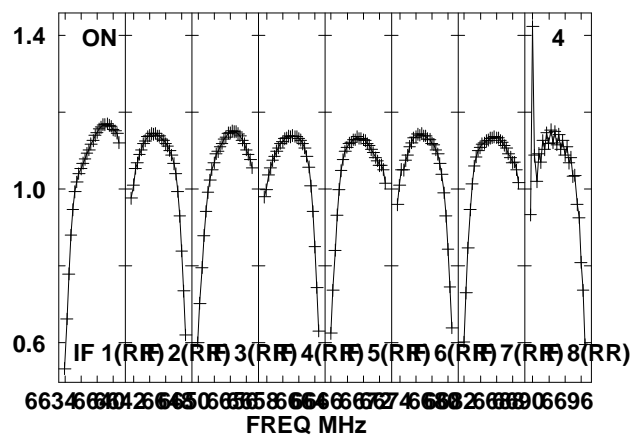
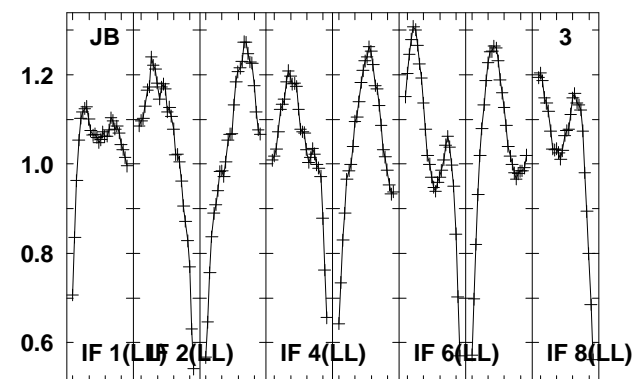
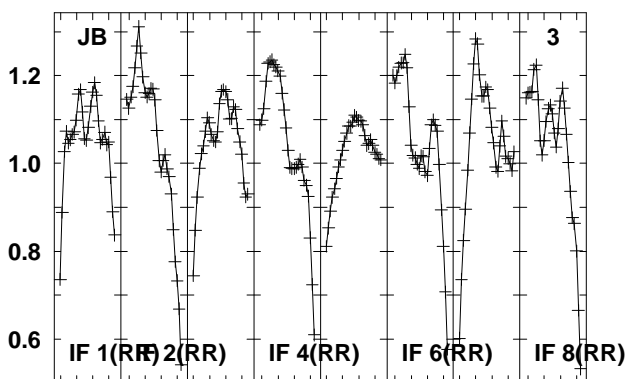
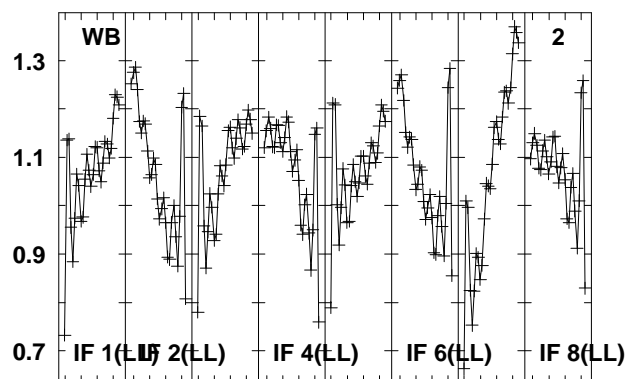
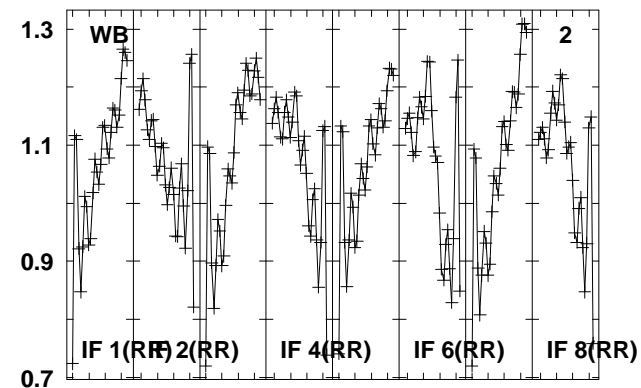
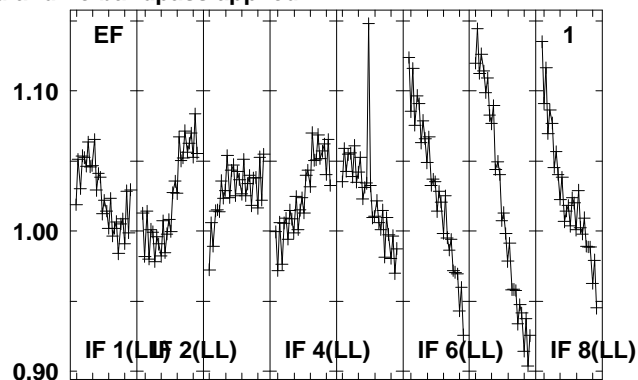
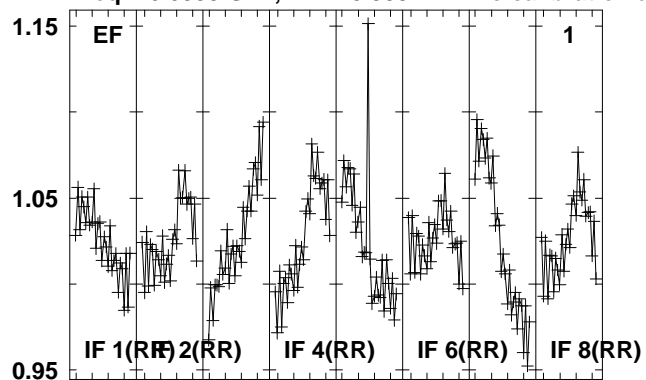

Lower frame: Real Jy

Total-power spectrum Antenna: *

Timerange: 00/13:32:52 to 00/13:34:20

Plot file version 140 created 15-MAR-2012 17:32:04

G85.40 EZ020E 2.UVDATA.1

Freq = 6.6335 GHz, Bw = 8.000 MH No calibration applied and no bandpass applied

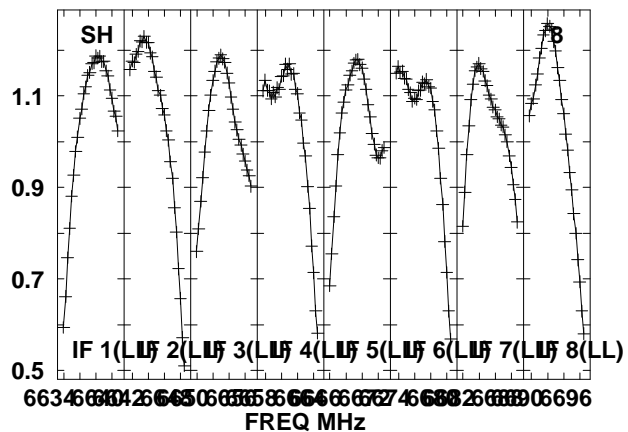
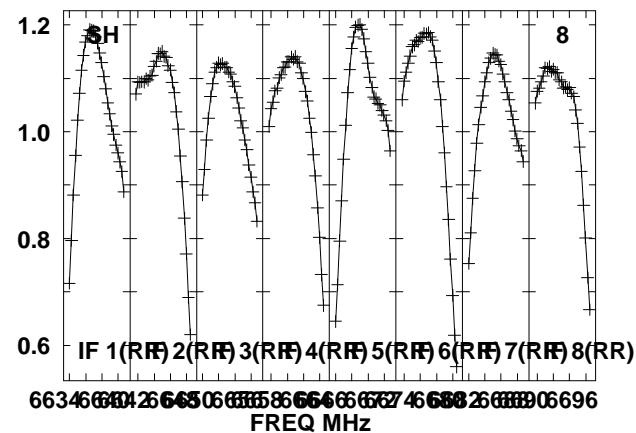
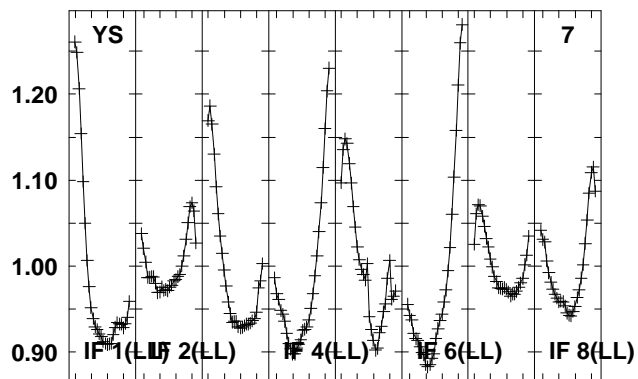
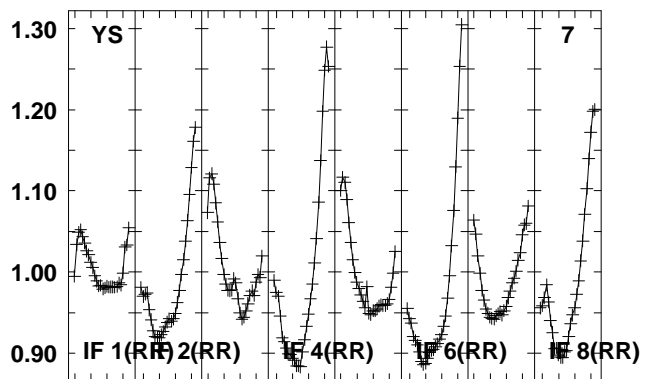
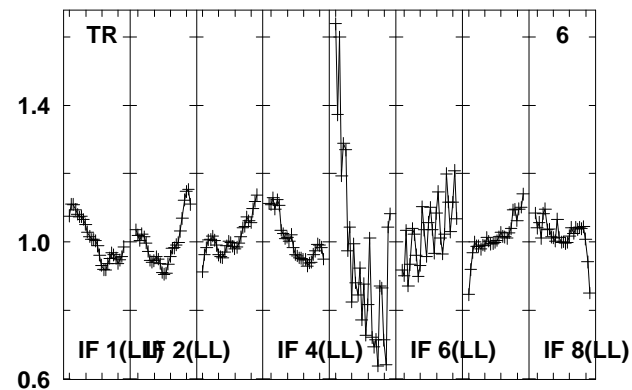
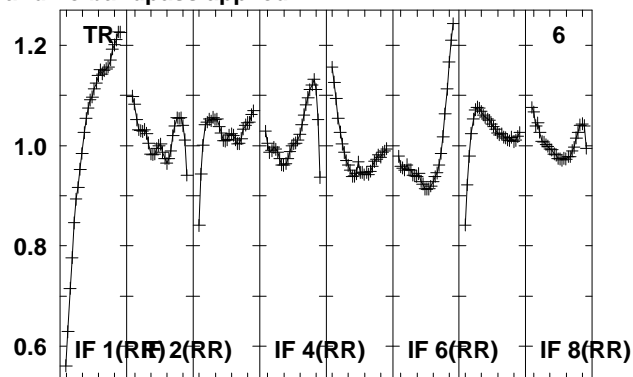
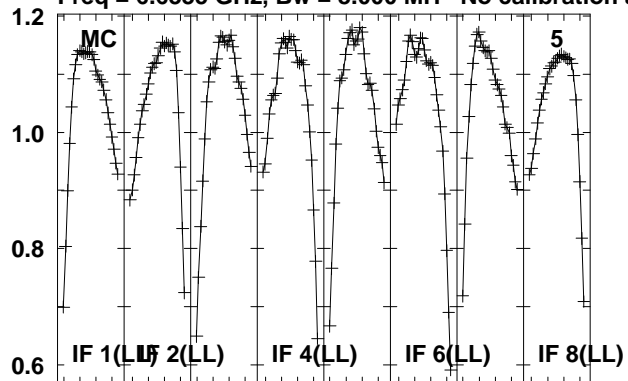

Lower frame: Real Jy

Total-power spectrum Antenna: *

Timerange: 00/13:32:52 to 00/13:34:20

Plot file version 141 created 15-MAR-2012 17:32:05
 2102-G85 EZ020E 2.UVDATA.1
 Freq = 6.6335 GHz, Bw = 8.000 MH No calibration applied and no bandpass applied

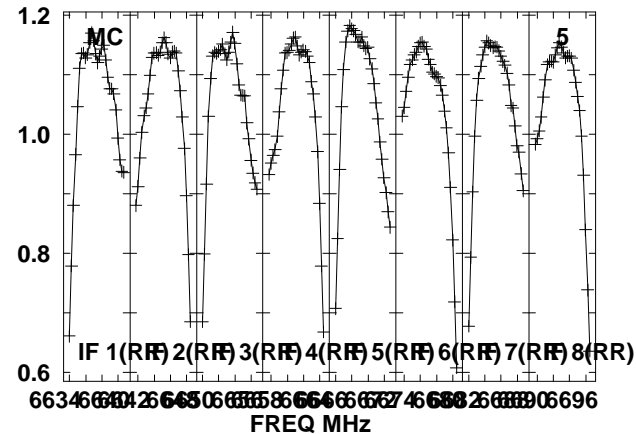
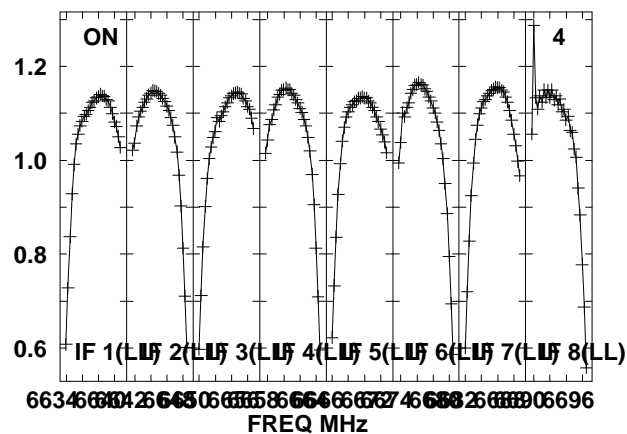
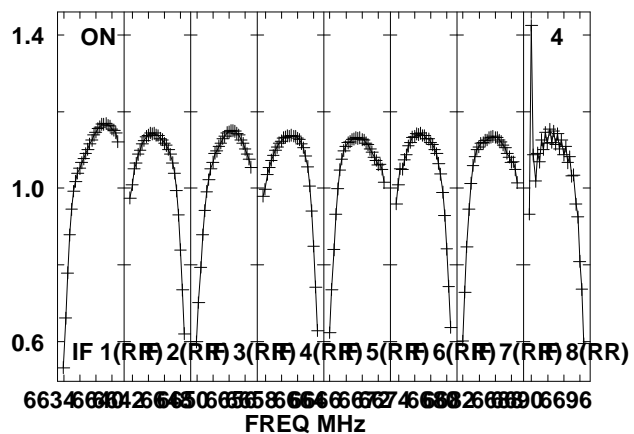
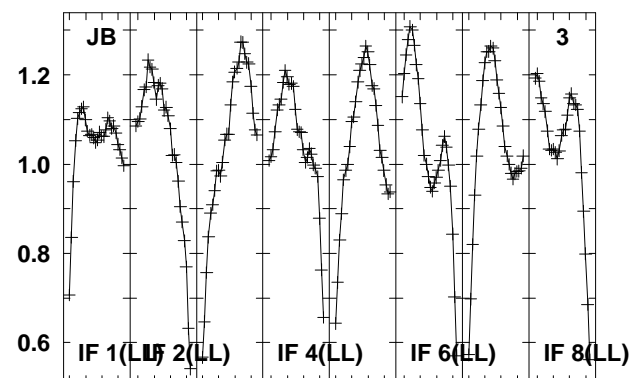
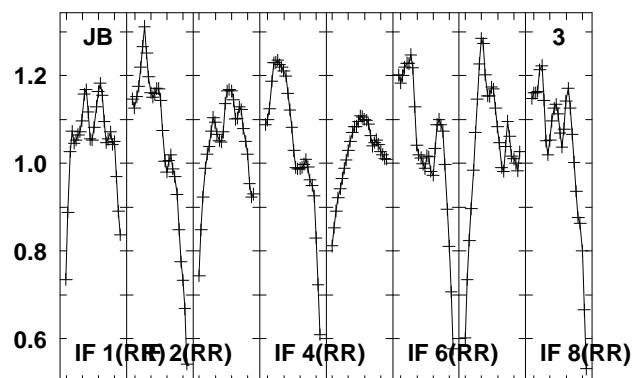
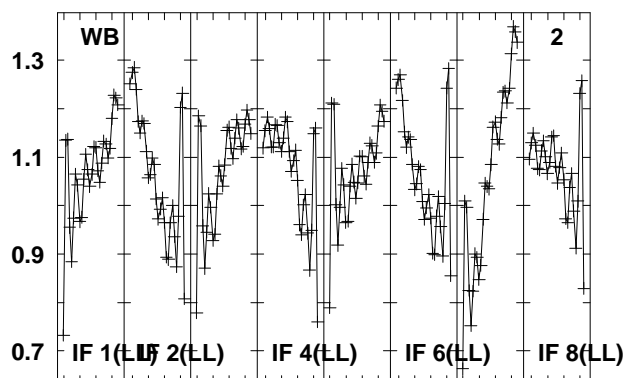
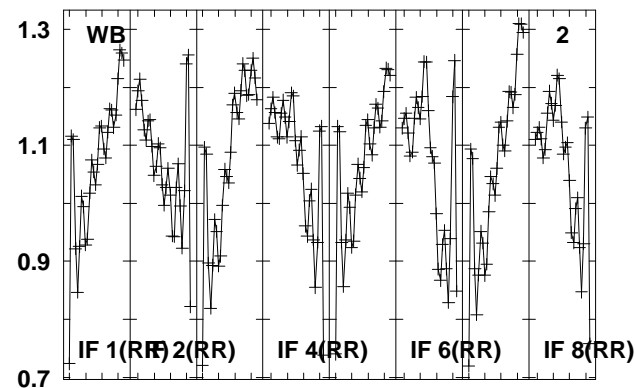
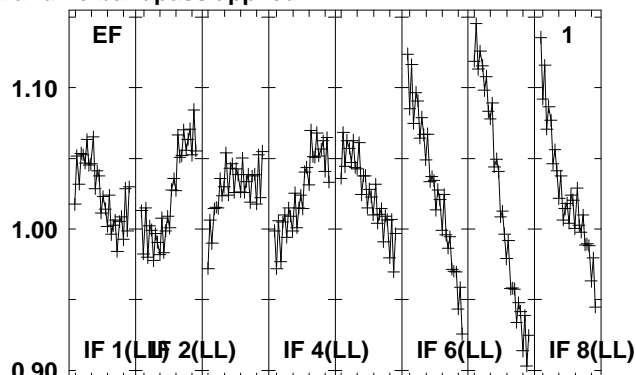
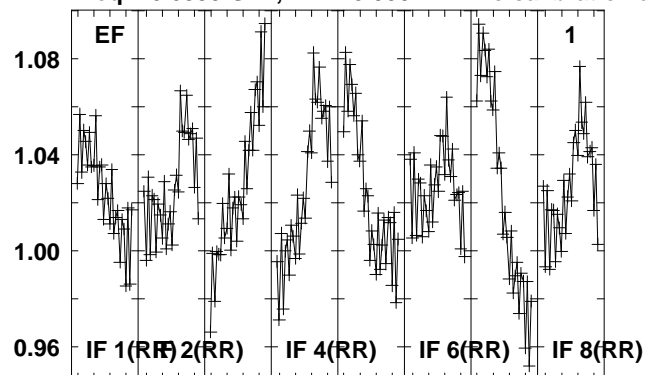

Lower frame: Real Jy
 Total-power spectrum Antenna: *
 Timerange: 00/13:34:22 to 00/13:35:50

Plot file version 142 created 15-MAR-2012 17:32:06

2102-G85 EZ020E 2.UVDATA.1

Freq = 6.6335 GHz, Bw = 8.000 MH No calibration applied and no bandpass applied

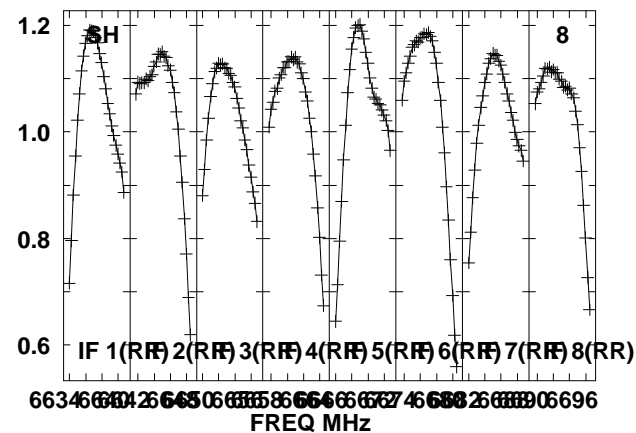
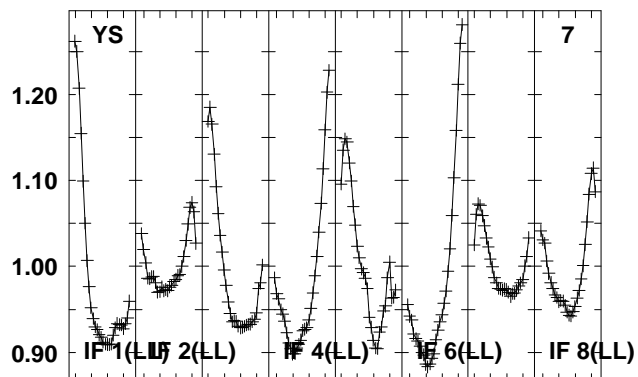
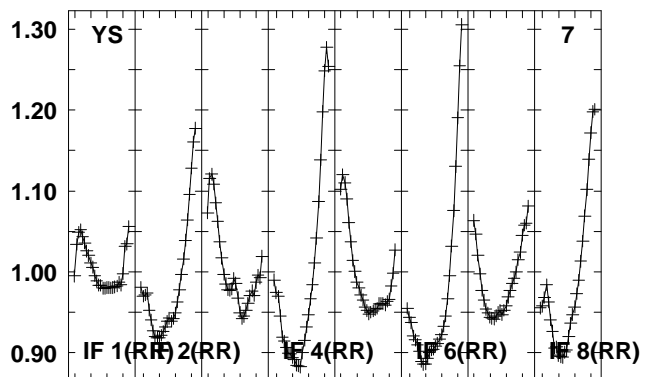
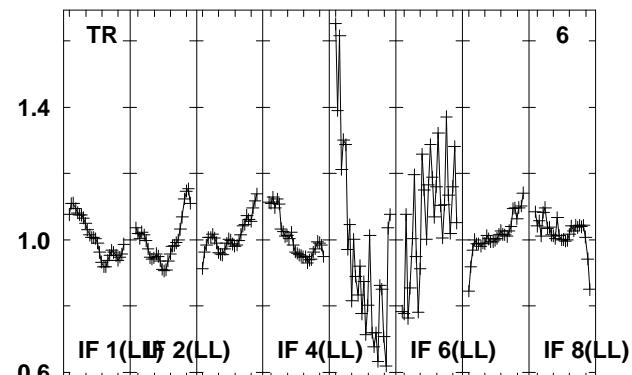
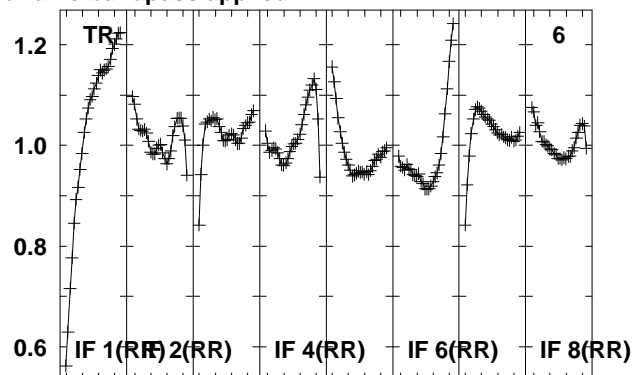
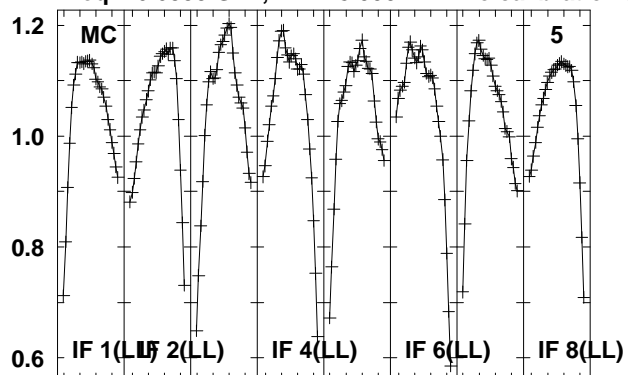

Plot file version 143 created 15-MAR-2012 17:32:07
 G85.40 EZ020E 2.UVDATA.1
 Freq = 6.6335 GHz, Bw = 8.000 MH No calibration applied and no bandpass applied

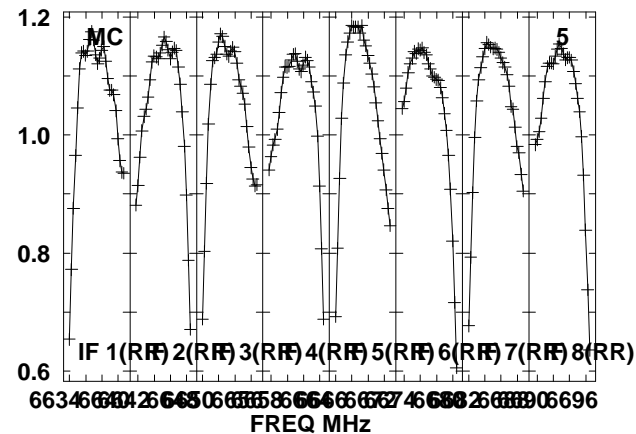
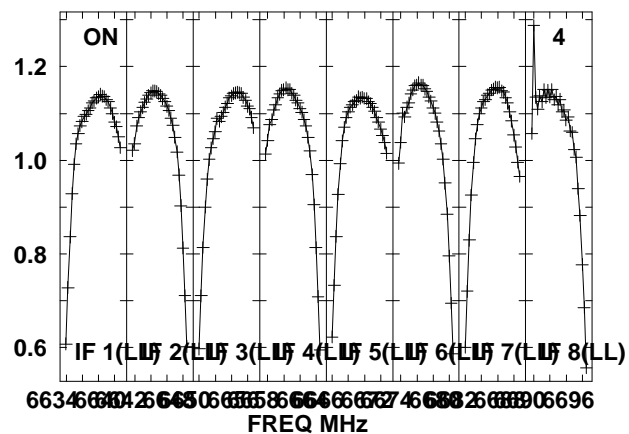
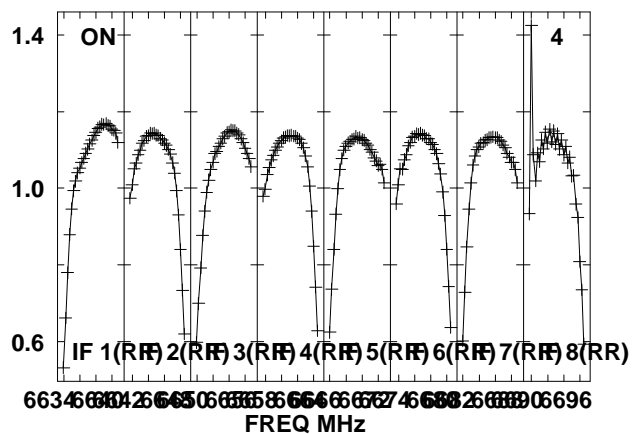
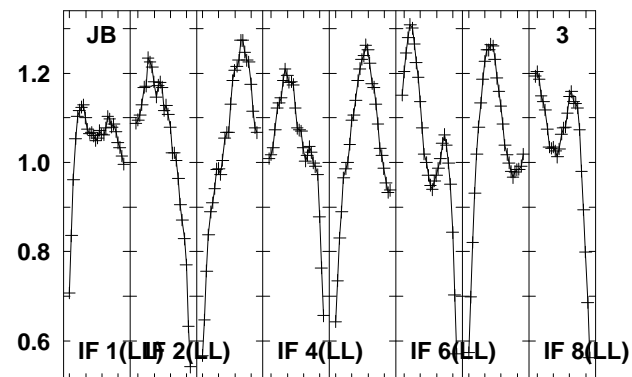
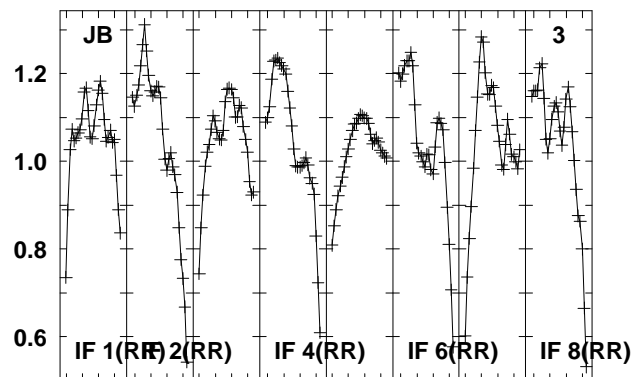
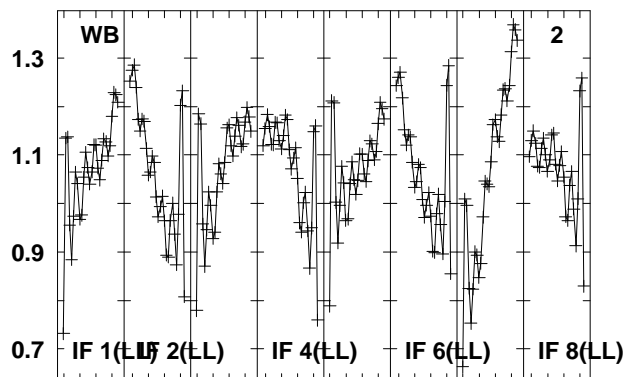
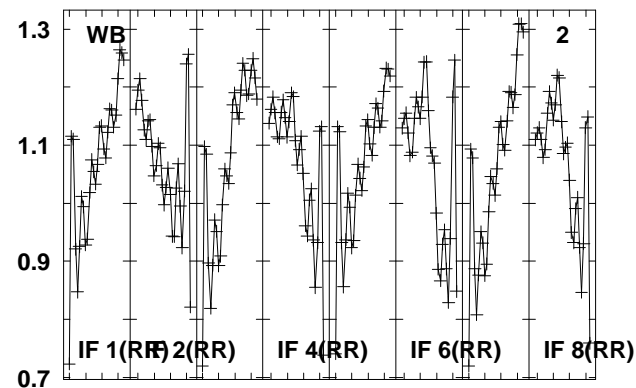
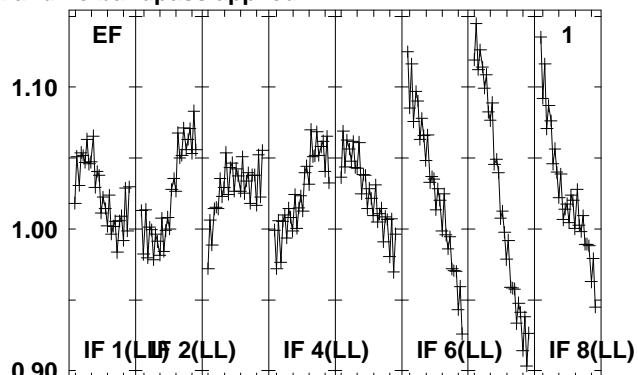
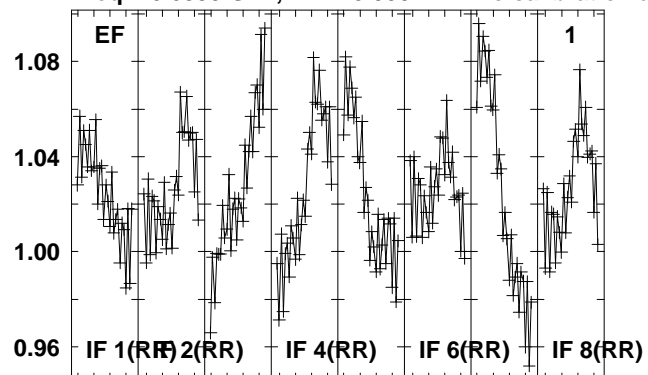

Lower frame: Real Jy
 Total-power spectrum Antenna: *
 Timerange: 00/13:35:53 to 00/13:37:21

Plot file version 144 created 15-MAR-2012 17:32:07

G85.40 EZ020E 2.UVDATA.1

Freq = 6.6335 GHz, Bw = 8.000 MH No calibration applied and no bandpass applied

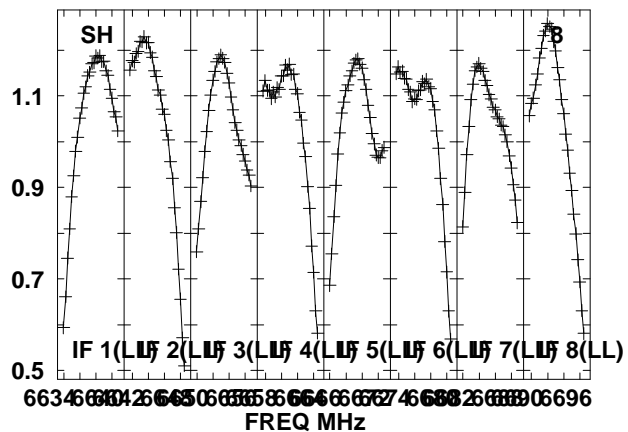
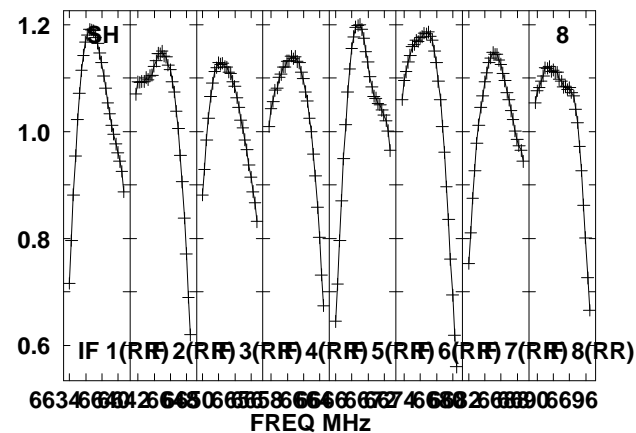
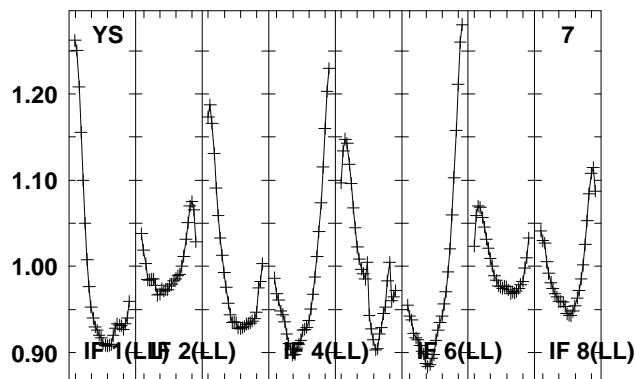
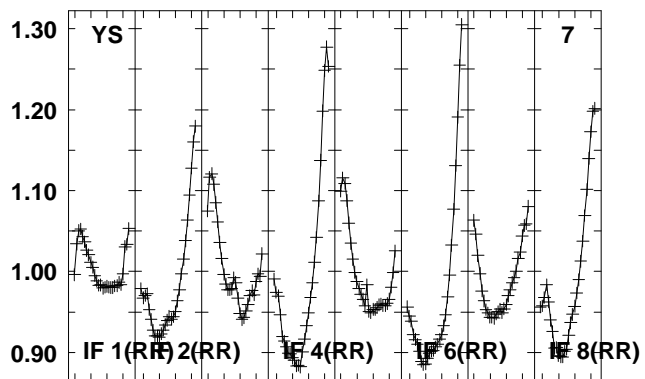
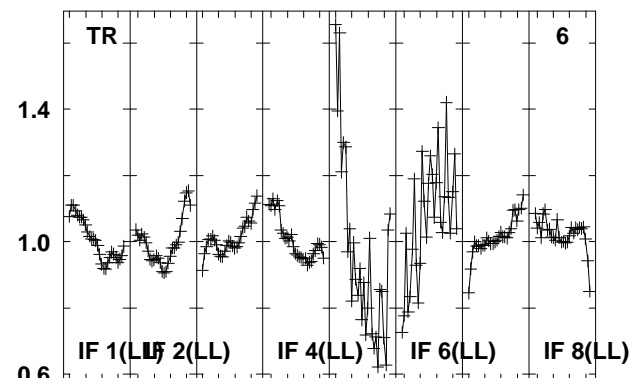
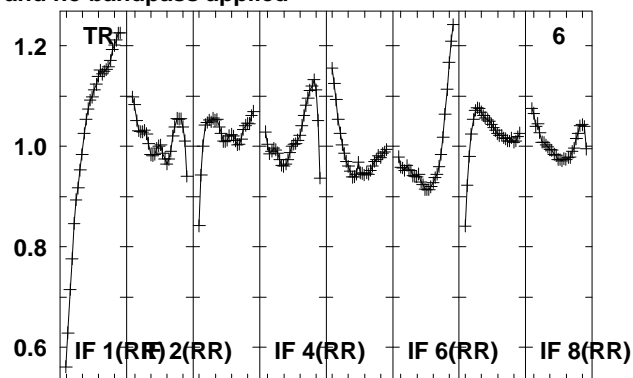
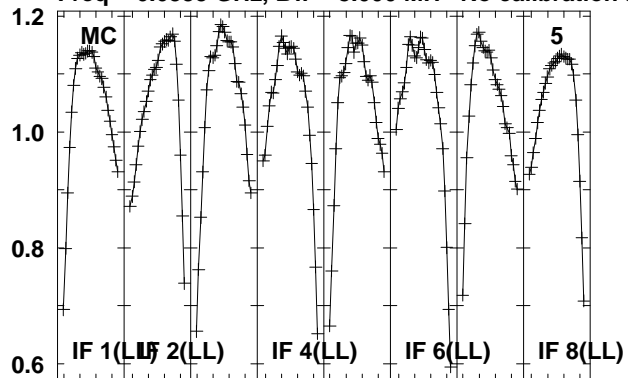

Lower frame: Real Jy

Total-power spectrum Antenna: *

Timerange: 00/13:35:53 to 00/13:37:21

Plot file version 145 created 15-MAR-2012 17:32:08

2114-G85 EZ020E 2.UVDATA.1

Freq = 6.6335 GHz, Bw = 8.000 MH No calibration applied and no bandpass applied

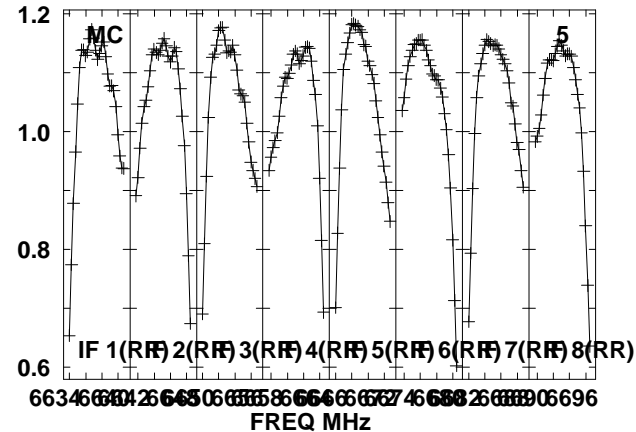
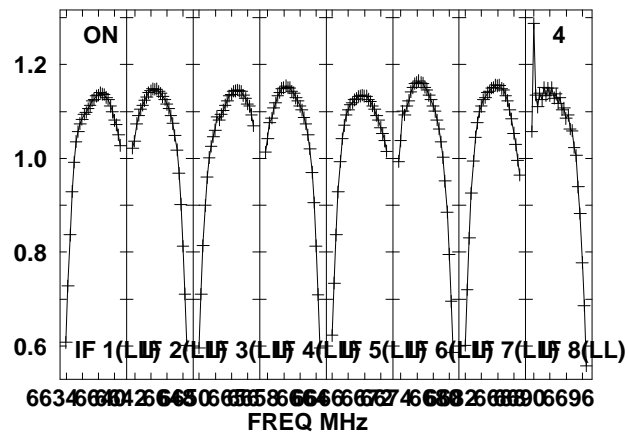
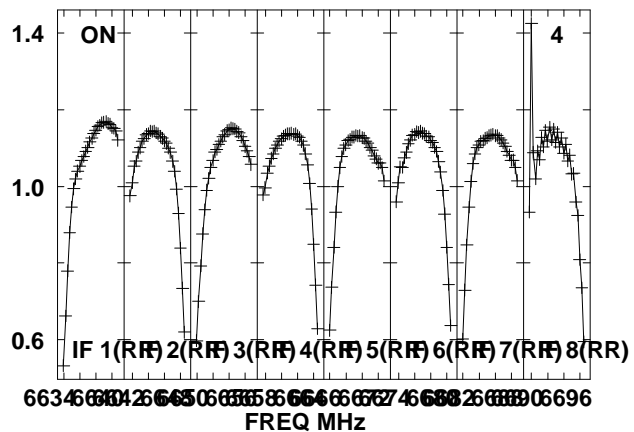
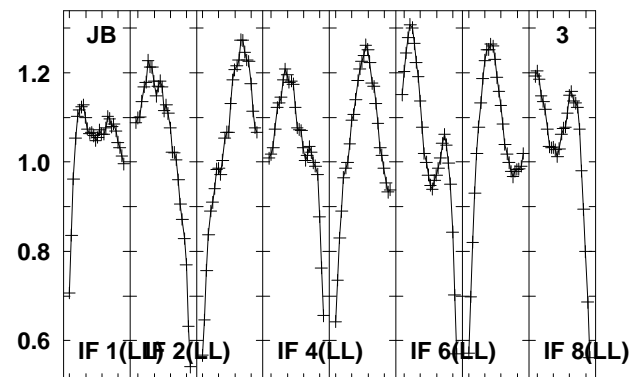
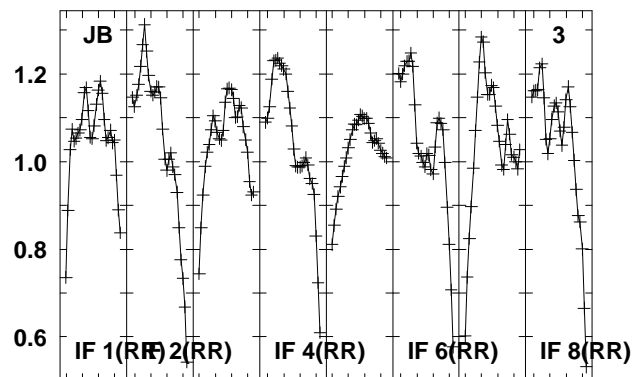
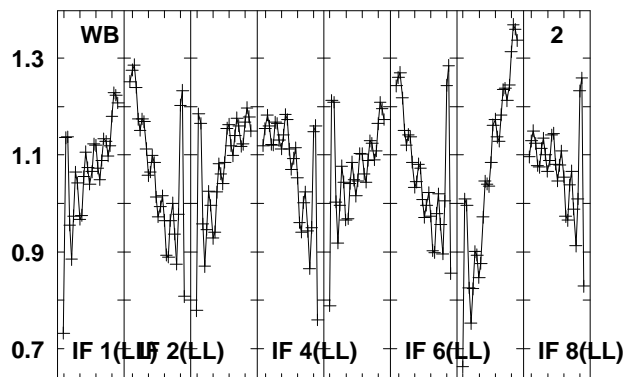
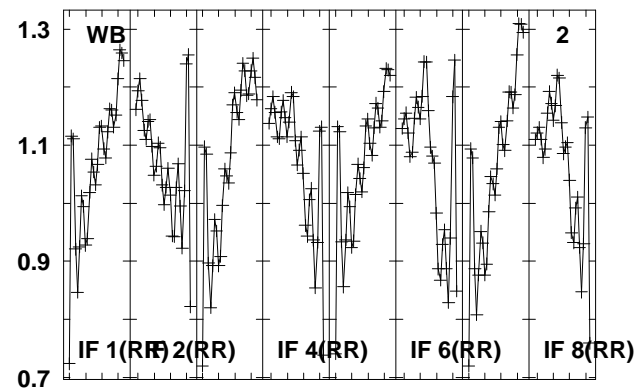
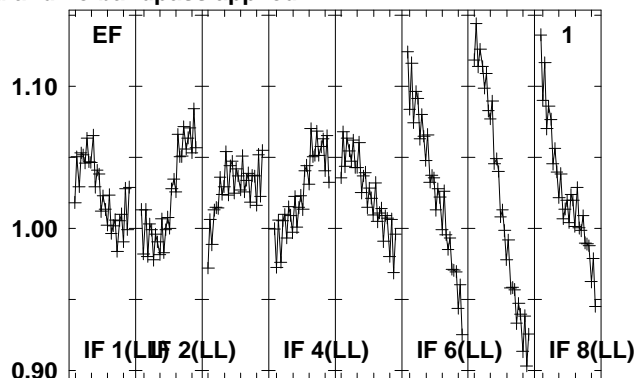
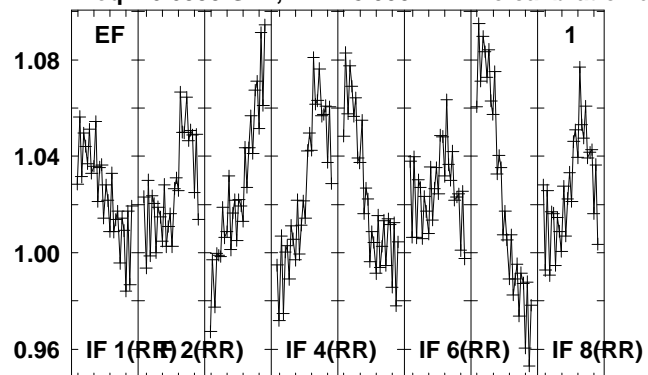

Lower frame: Real Jy
Total-power spectrum Antenna: *
Timerange: 00/13:37:23 to 00/13:38:51

Plot file version 146 created 15-MAR-2012 17:32:09

2114-G85 EZ020E 2.UVDATA.1

Freq = 6.6335 GHz, Bw = 8.000 MH No calibration applied and no bandpass applied

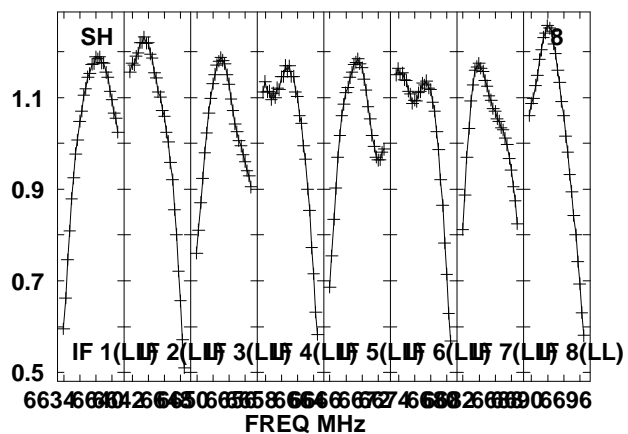
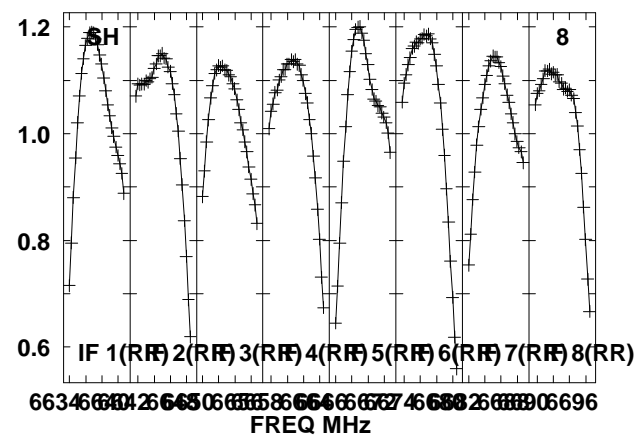
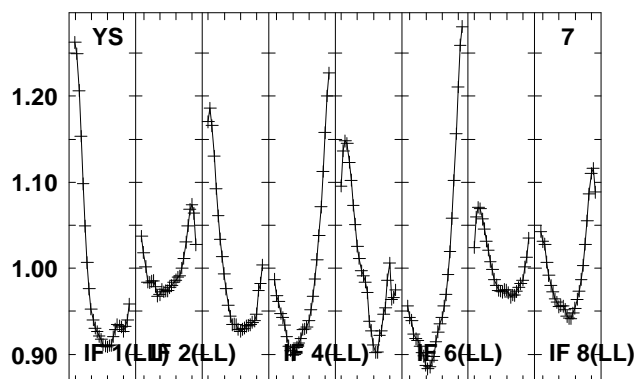
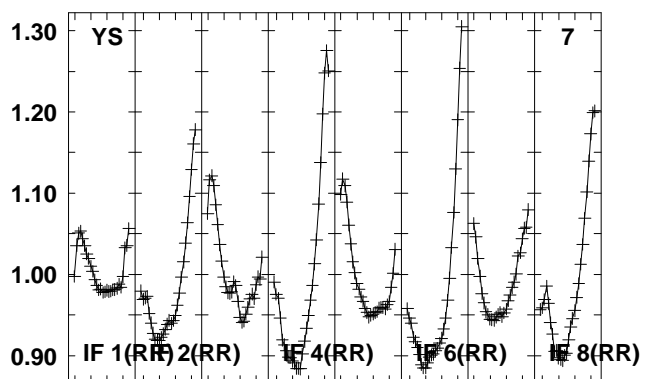
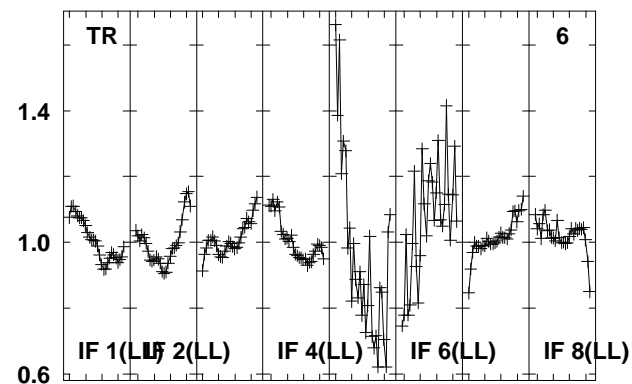
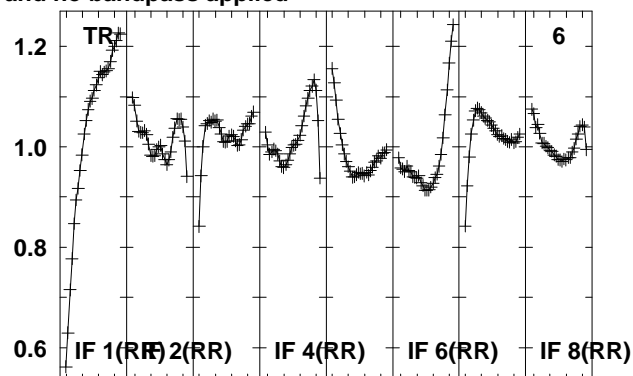
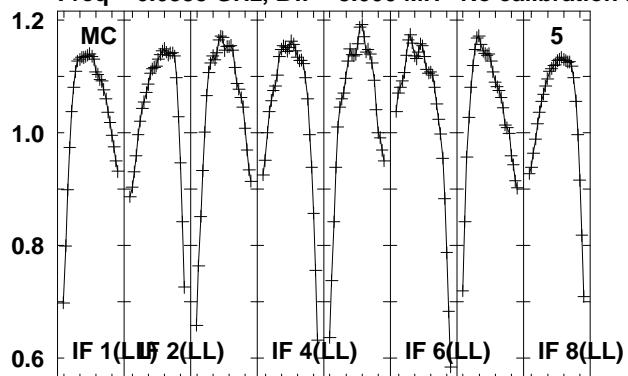

Lower frame: Real Jy
Total-power spectrum Antenna: *
Timerange: 00/13:37:23 to 00/13:38:51

Plot file version 147 created 15-MAR-2012 17:32:09

G85.40 EZ020E 2.UVDATA.1

Freq = 6.6335 GHz, Bw = 8.000 MH No calibration applied and no bandpass applied

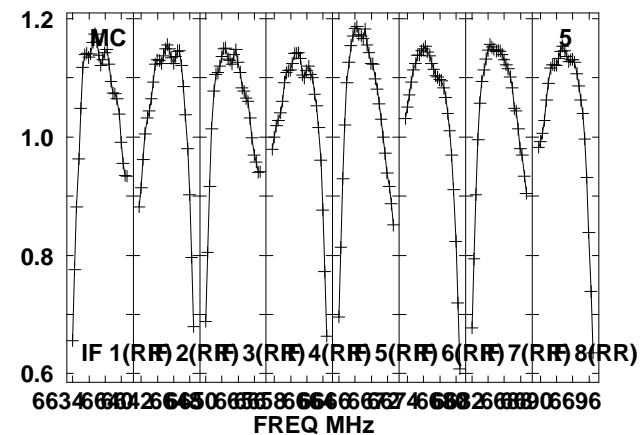
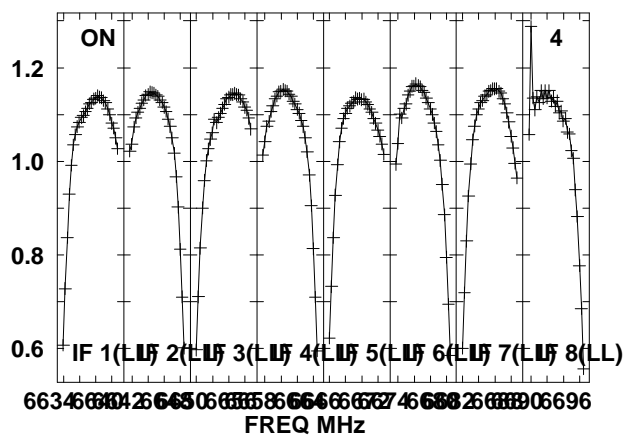
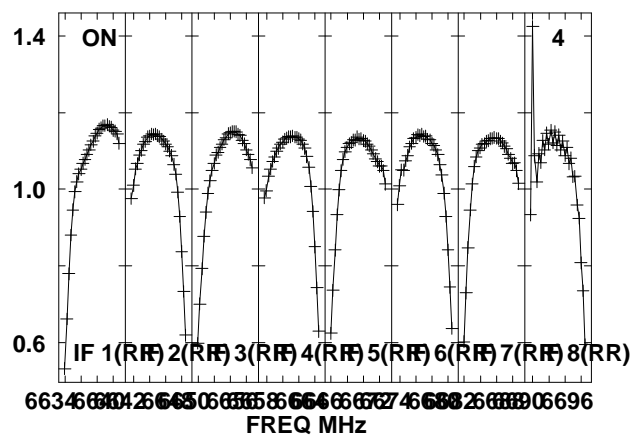
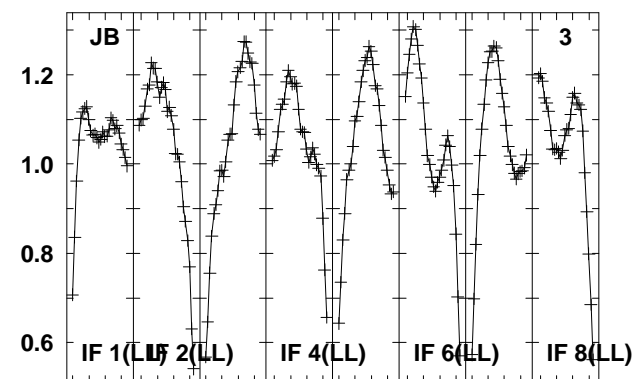
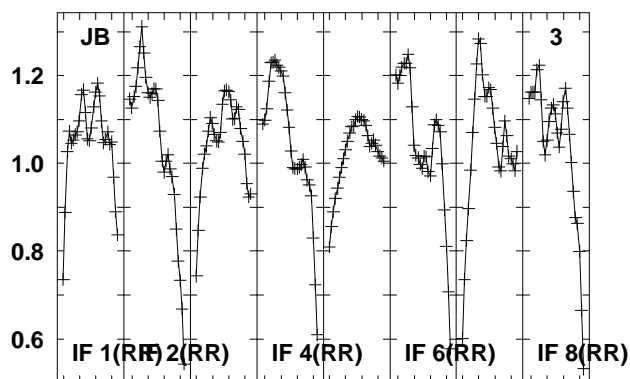
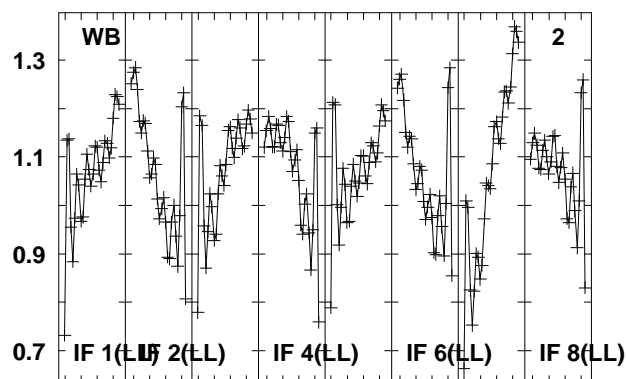
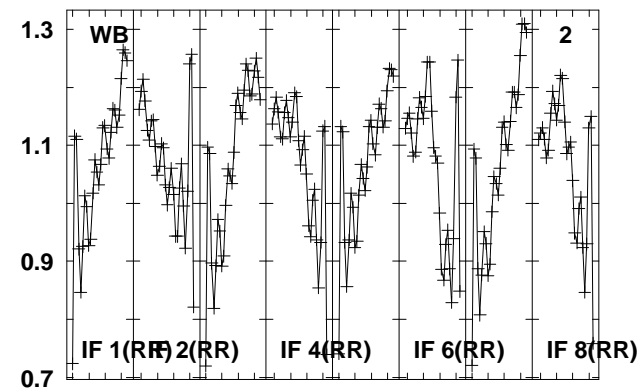
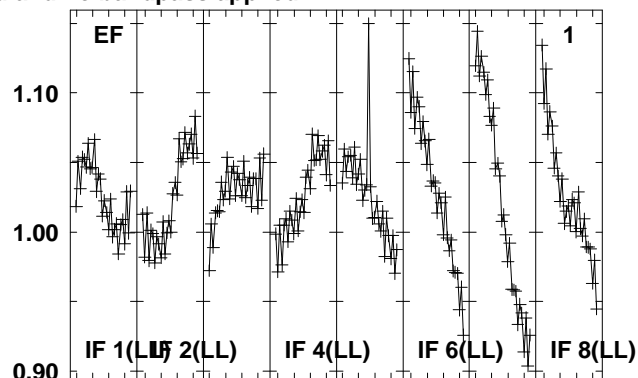
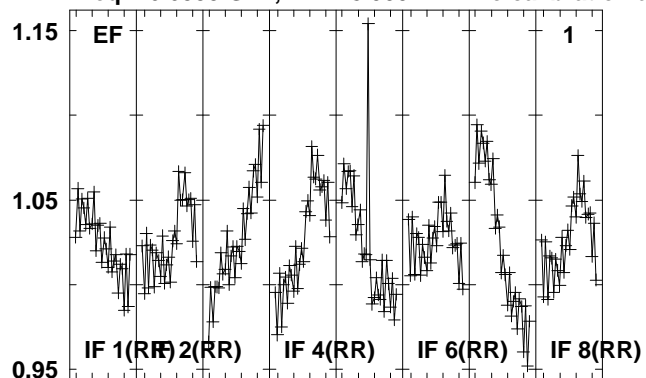

Lower frame: Real Jy
Total-power spectrum Antenna: *
Timerange: 00/13:38:52 to 00/13:40:20

Plot file version 148 created 15-MAR-2012 17:32:10

G85.40 EZ020E 2.UVDATA.1

Freq = 6.6335 GHz, Bw = 8.000 MH No calibration applied and no bandpass applied

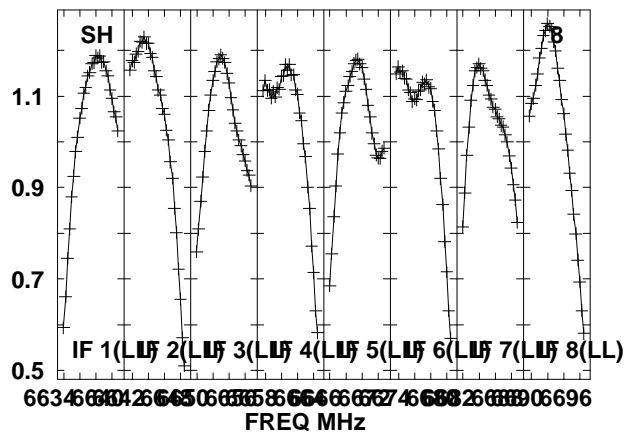
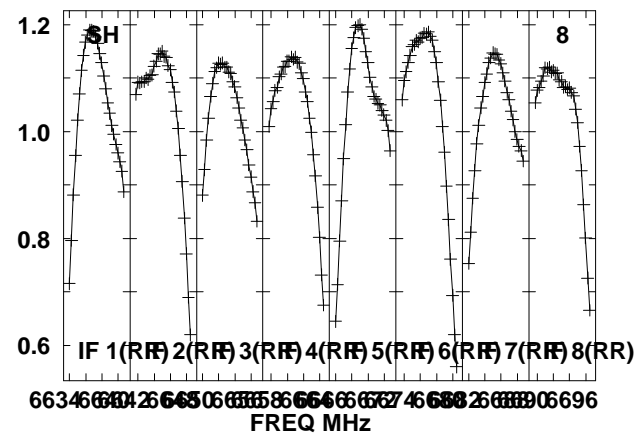
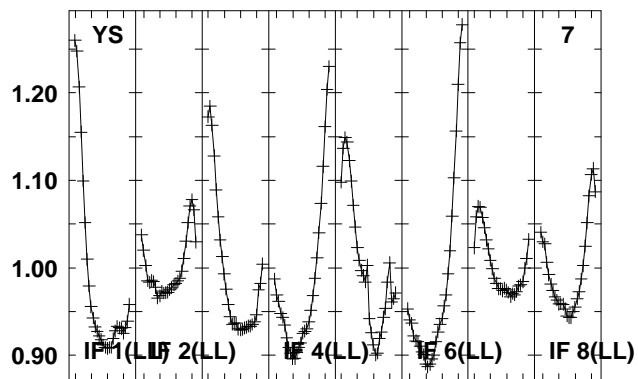
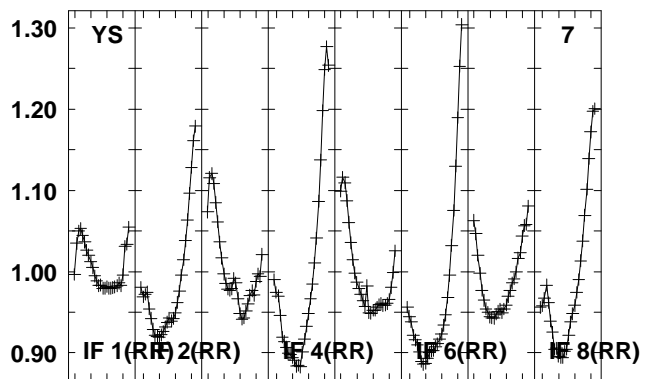
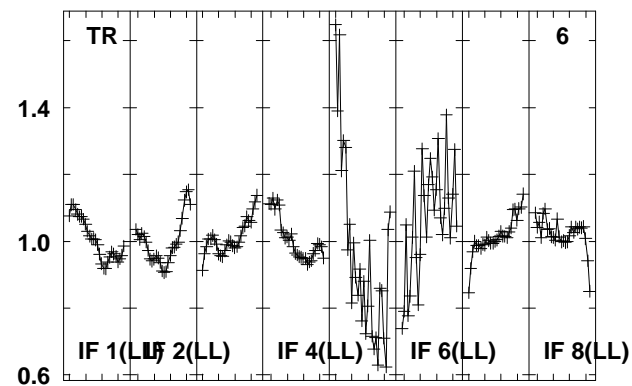
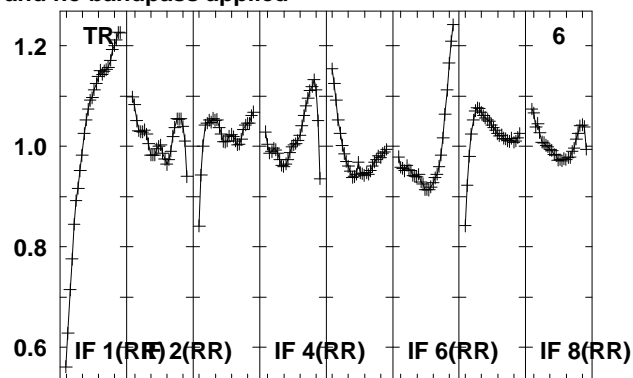
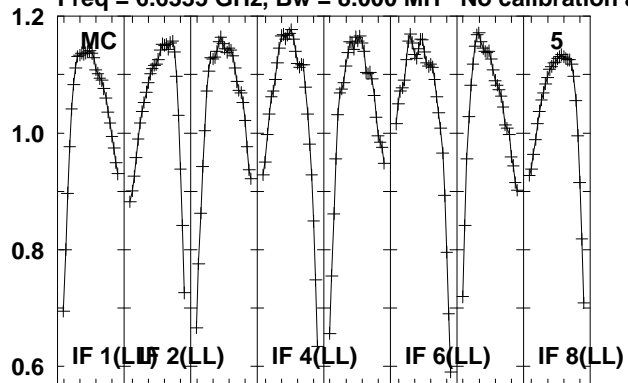

Lower frame: Real Jy
Total-power spectrum Antenna: *
Timerange: 00/13:38:52 to 00/13:40:20

Plot file version 149 created 15-MAR-2012 17:32:11
 2102-G85 EZ020E 2.UVDATA.1
 Freq = 6.6335 GHz, Bw = 8.000 MH No calibration applied and no bandpass applied

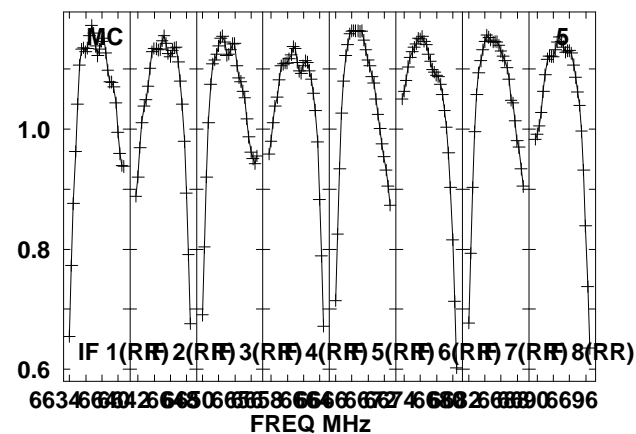
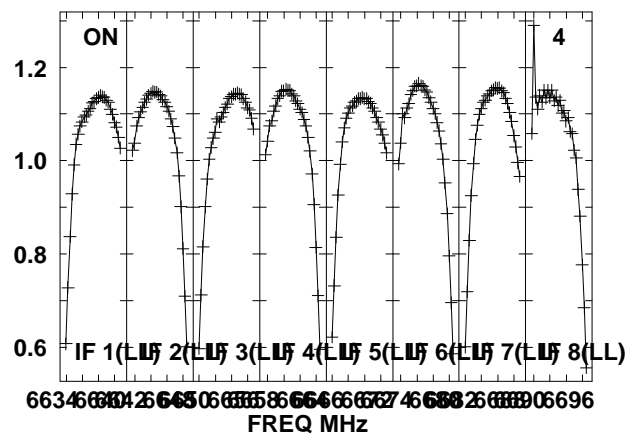
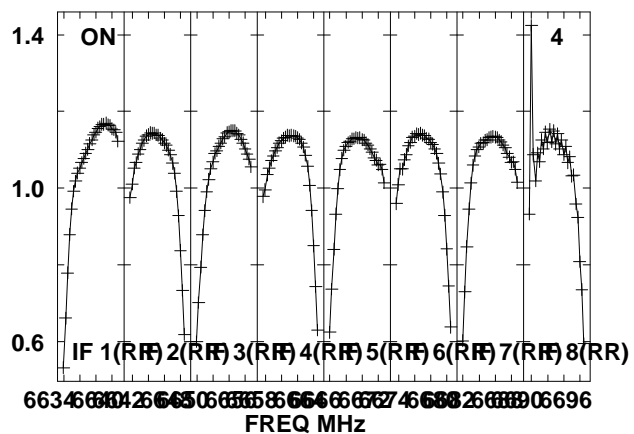
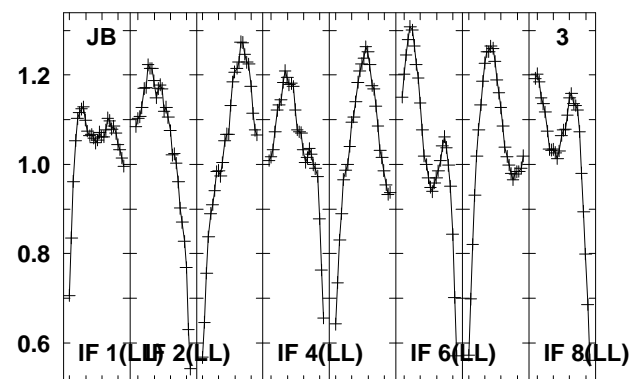
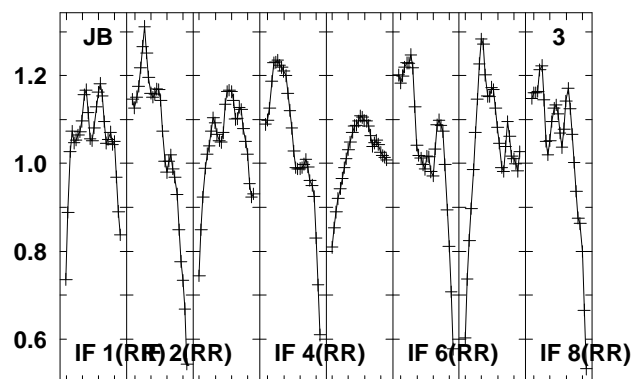
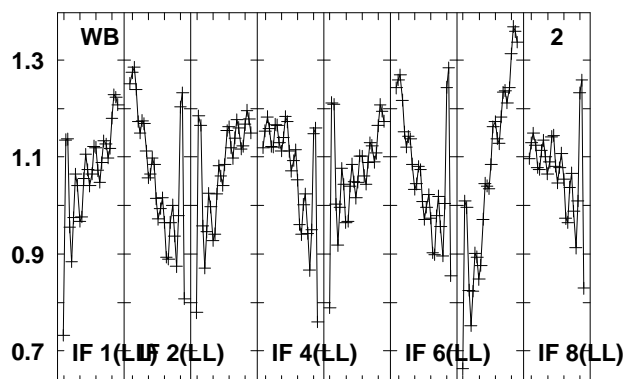
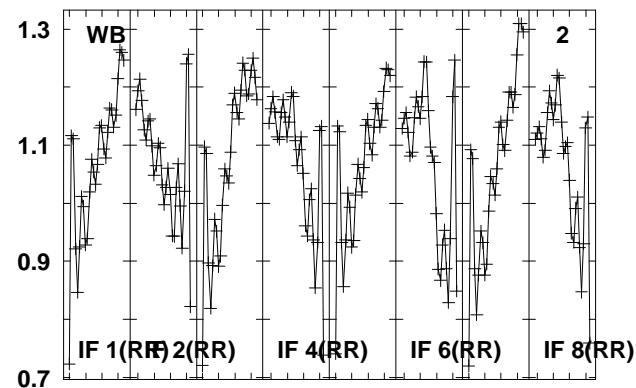
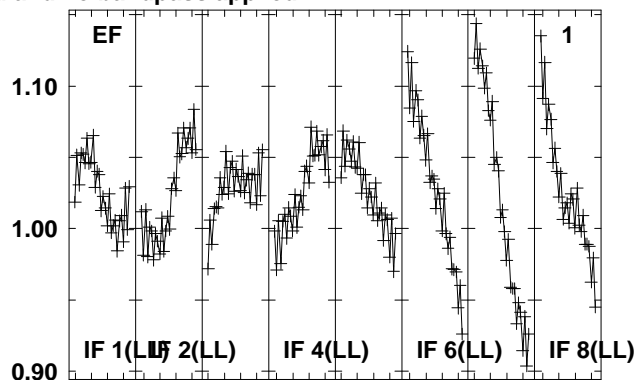
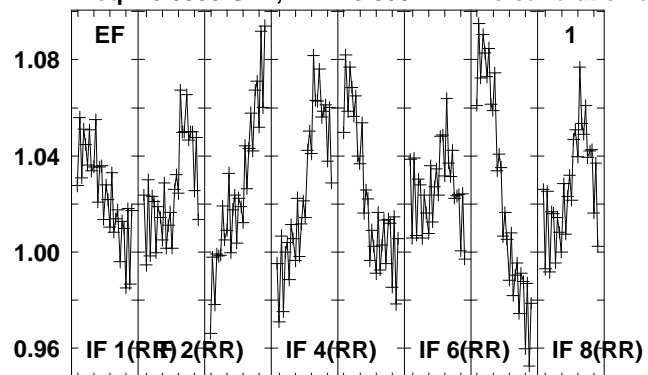

Lower frame: Real Jy
 Total-power spectrum Antenna: *
 Timerange: 00/13:40:23 to 00/13:41:51

Plot file version 150 created 15-MAR-2012 17:32:12

2102-G85 EZ020E 2.UVDATA.1

Freq = 6.6335 GHz, Bw = 8.000 MH No calibration applied and no bandpass applied

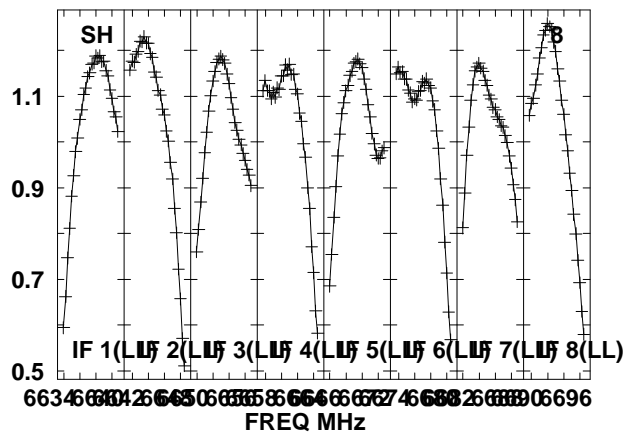
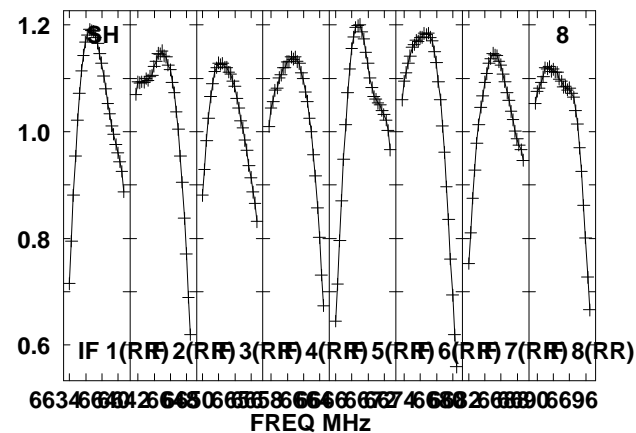
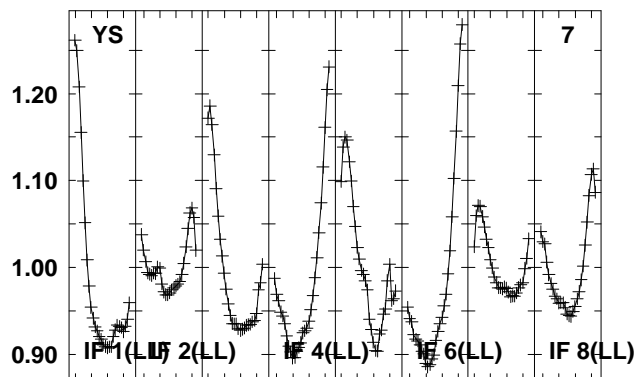
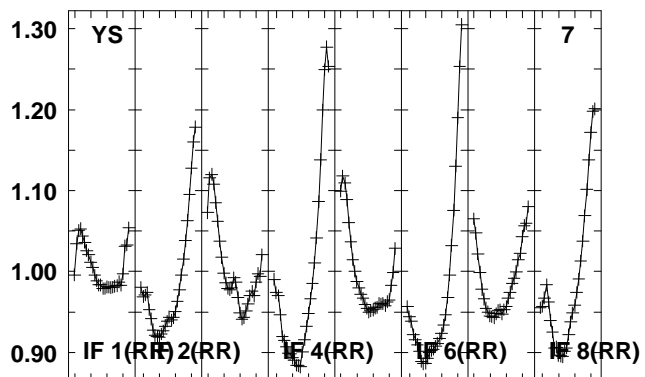
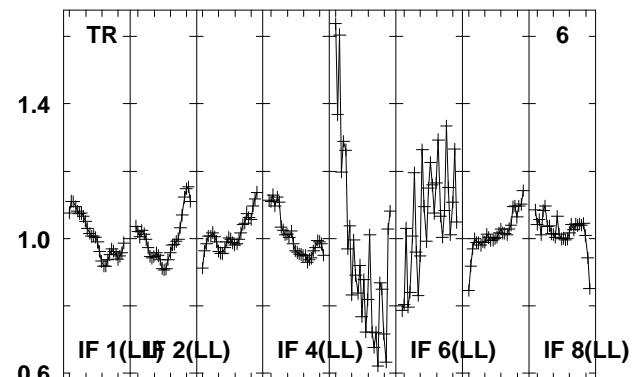
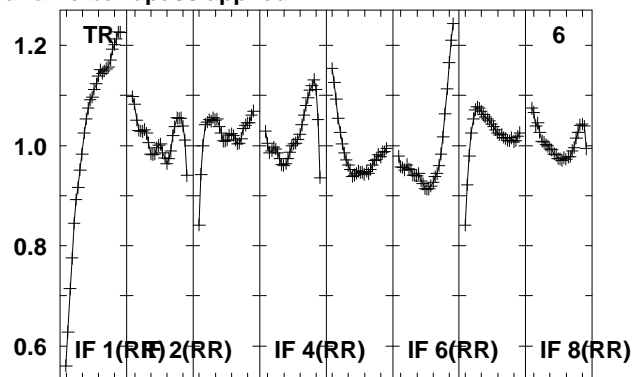
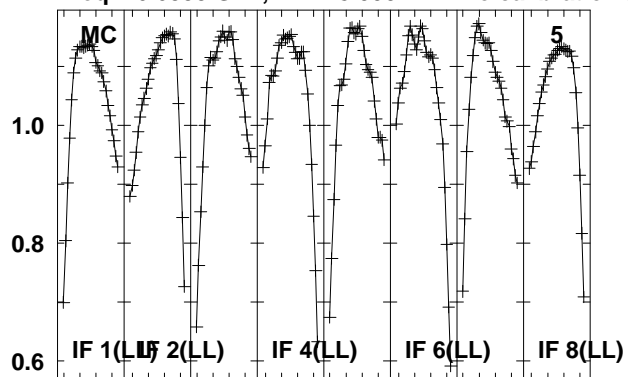

Lower frame: Real Jy
Total-power spectrum Antenna: *
Timerange: 00/13:40:23 to 00/13:41:51

Plot file version 151 created 15-MAR-2012 17:32:12

G85.40 EZ020E 2.UVDATA.1

Freq = 6.6335 GHz, Bw = 8.000 MH No calibration applied and no bandpass applied

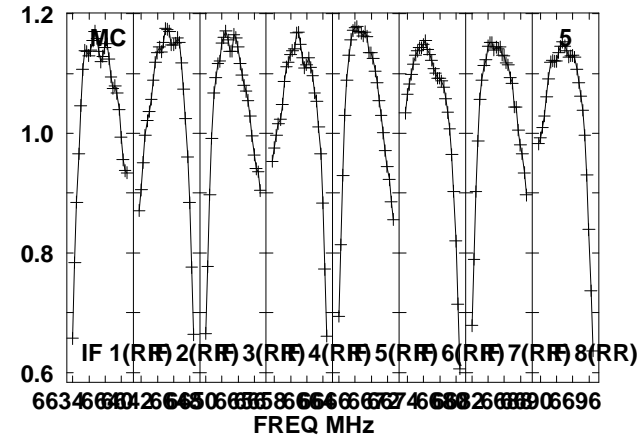
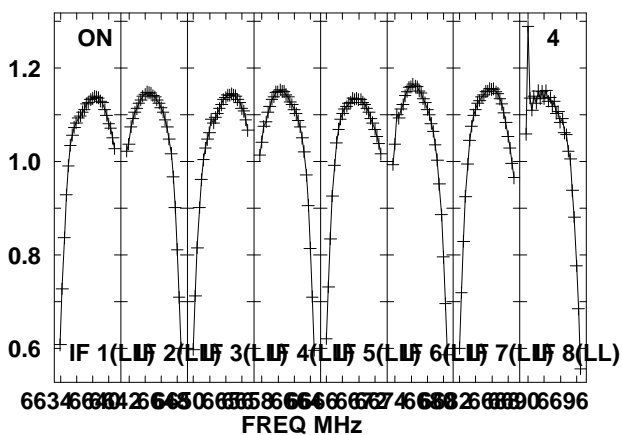
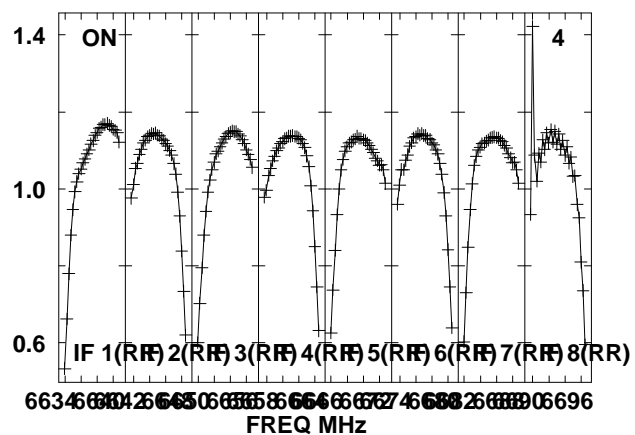
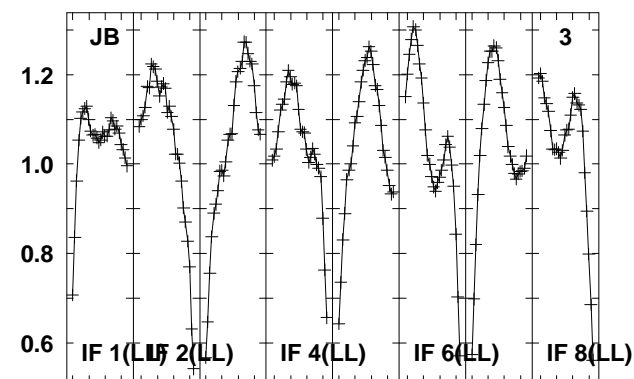
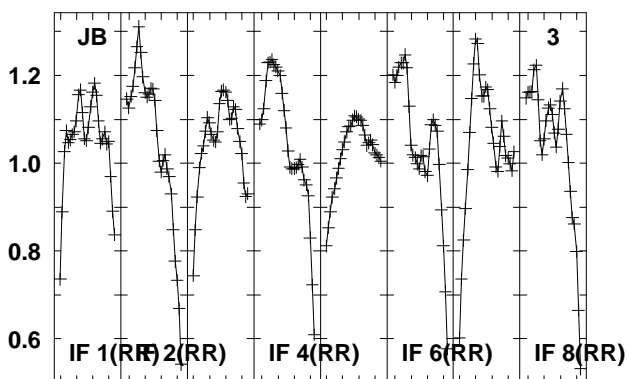
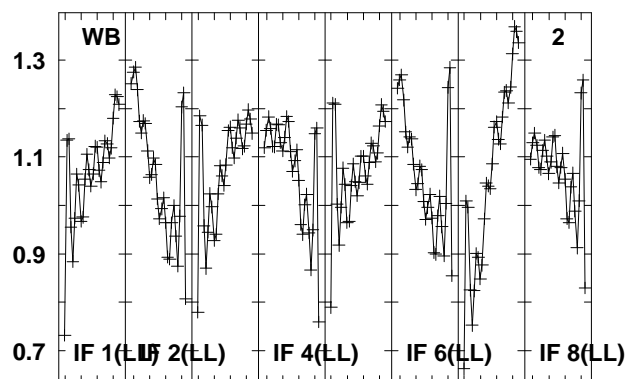
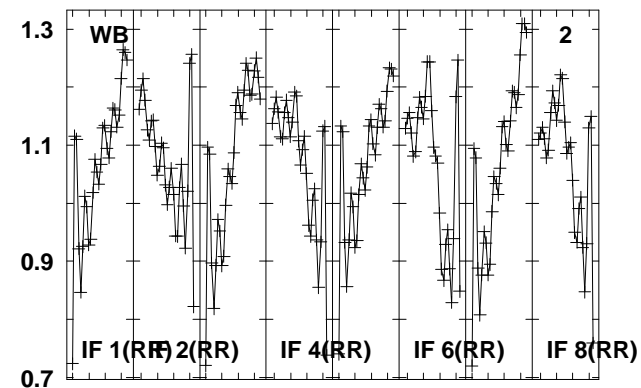
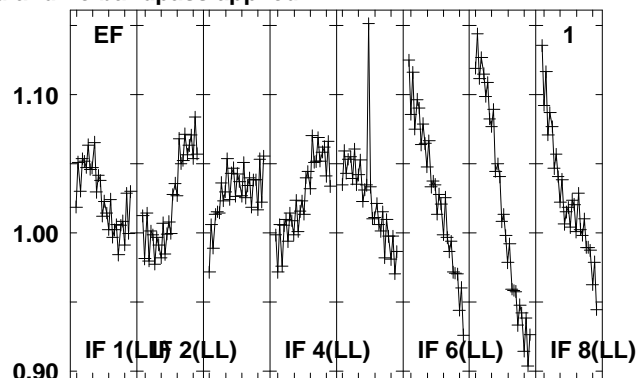
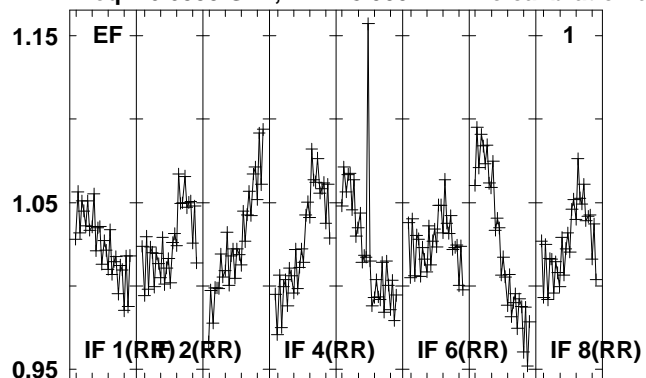

Lower frame: Real Jy

Total-power spectrum Antenna: *

Timerange: 00/13:42:29 to 00/13:43:28

Plot file version 152 created 15-MAR-2012 17:32:13

G85.40 EZ020E 2.UVDATA.1

Freq = 6.6335 GHz, Bw = 8.000 MH No calibration applied and no bandpass applied

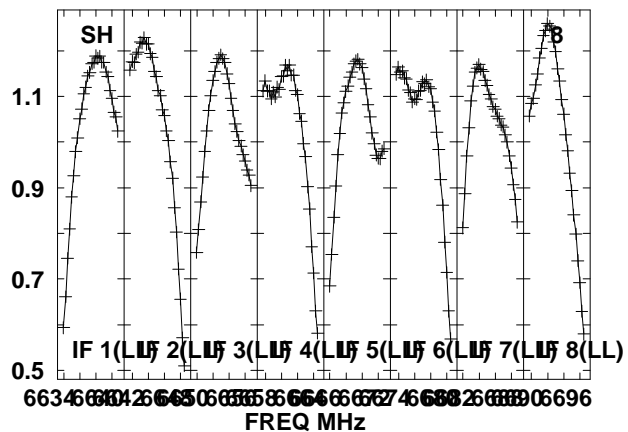
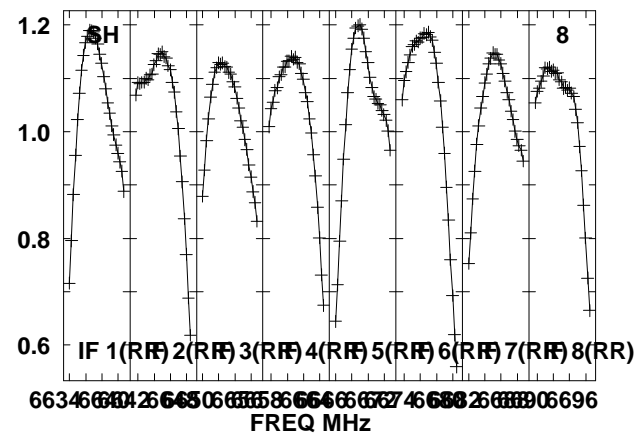
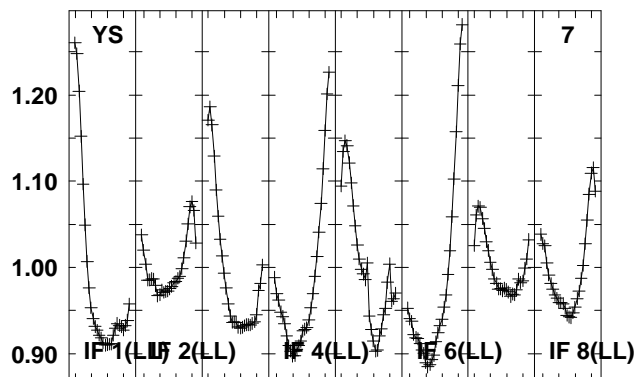
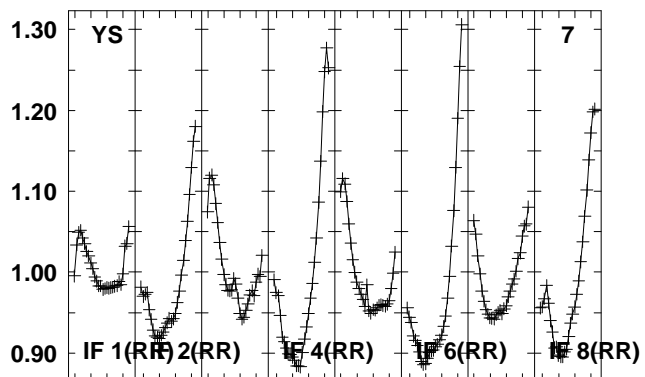
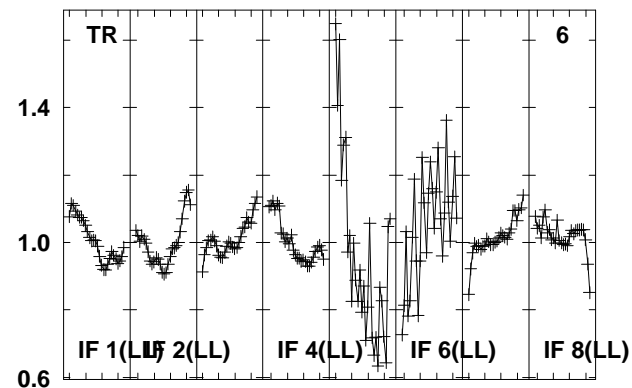
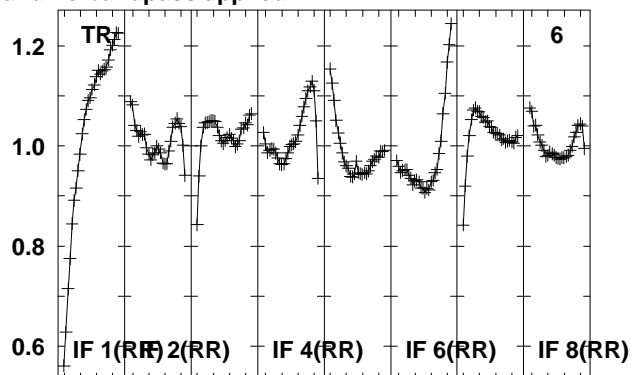
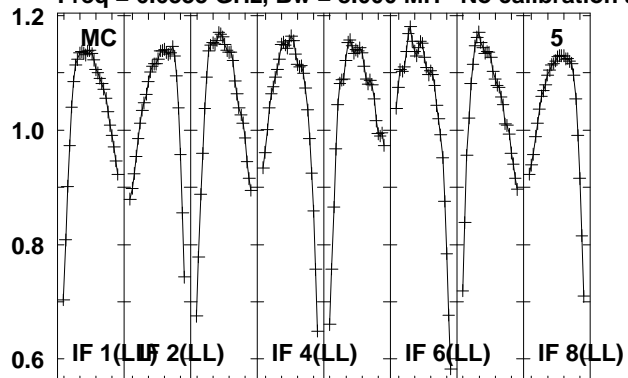

Lower frame: Real Jy

Total-power spectrum Antenna: *

Timerange: 00/13:42:29 to 00/13:43:28

Plot file version 153 created 15-MAR-2012 17:32:13
 2114-G85 EZ020E 2.UVDATA.1
 Freq = 6.6335 GHz, Bw = 8.000 MH No calibration applied and no bandpass applied

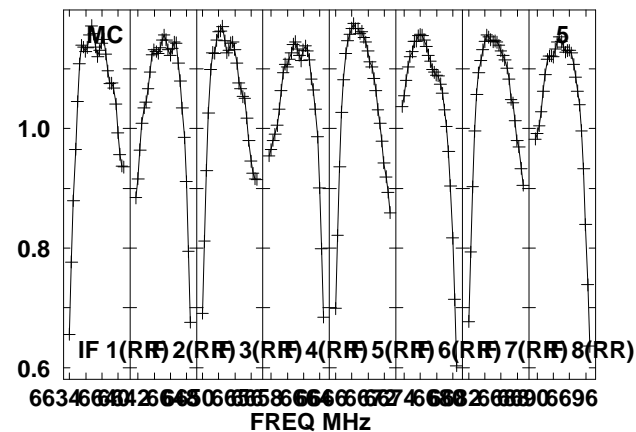
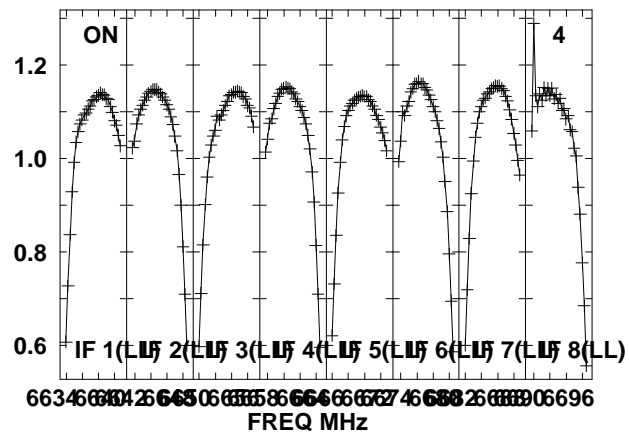
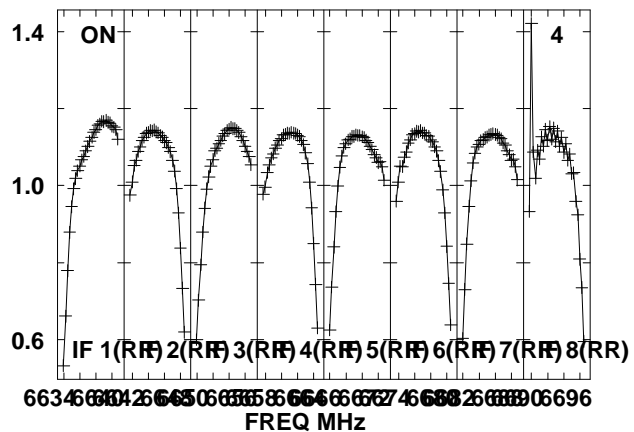
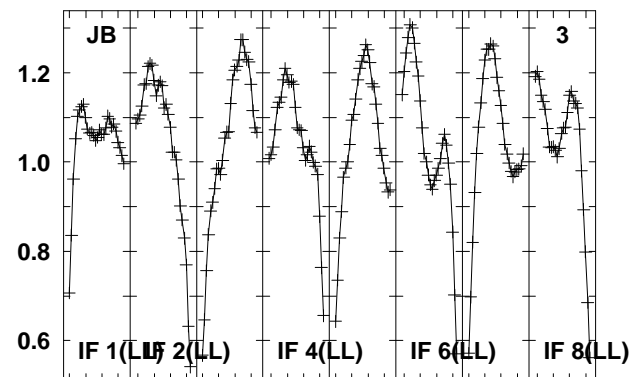
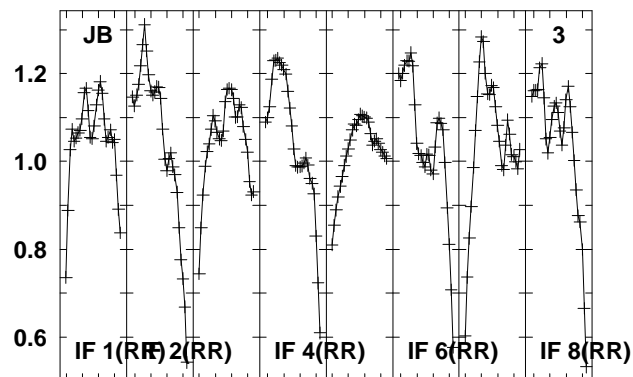
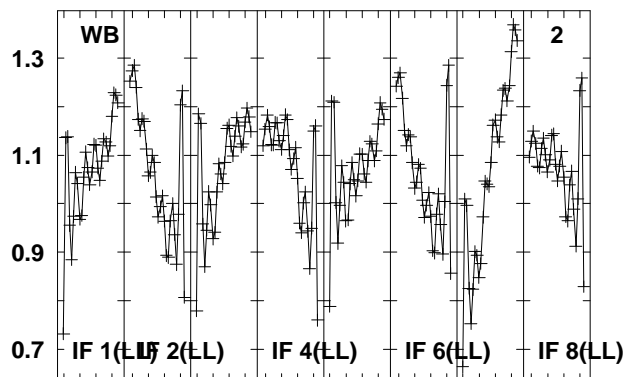
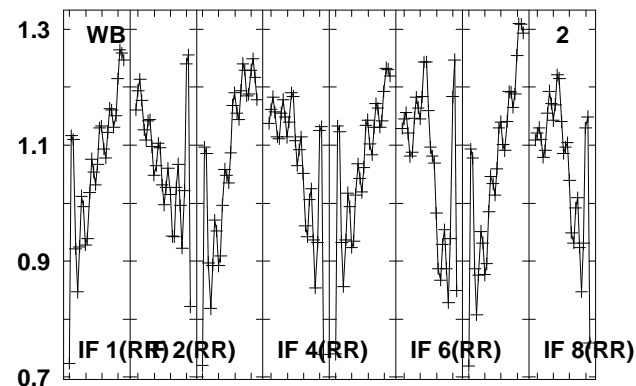
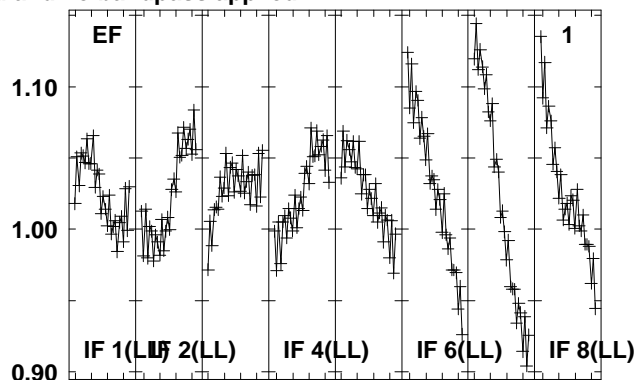
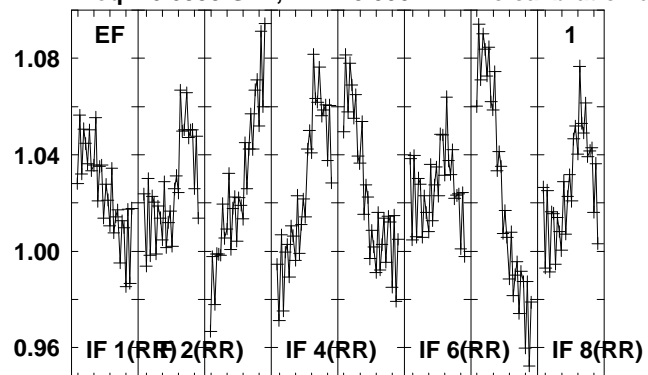

Lower frame: Real Jy
 Total-power spectrum Antenna: *
 Timerange: 00/13:43:29 to 00/13:44:57

Plot file version 155 created 15-MAR-2012 17:32:15

G85.40 EZ020E 2.UVDATA.1

Freq = 6.6335 GHz, Bw = 8.000 MH No calibration applied and no bandpass applied

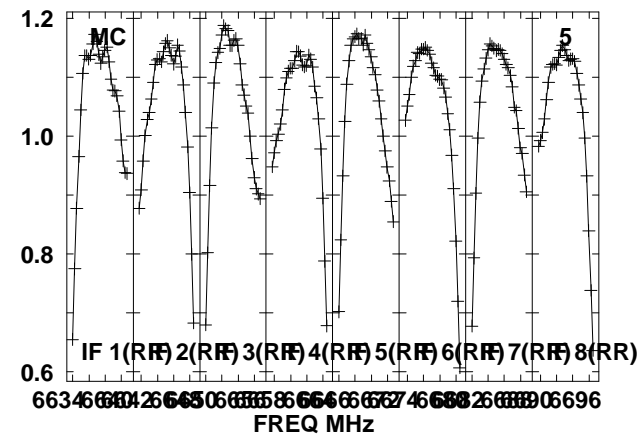
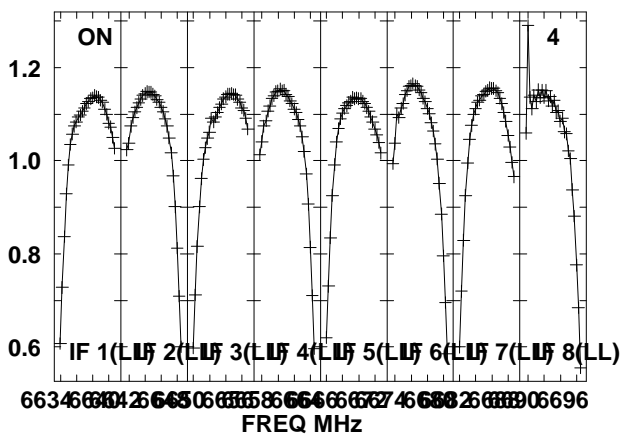
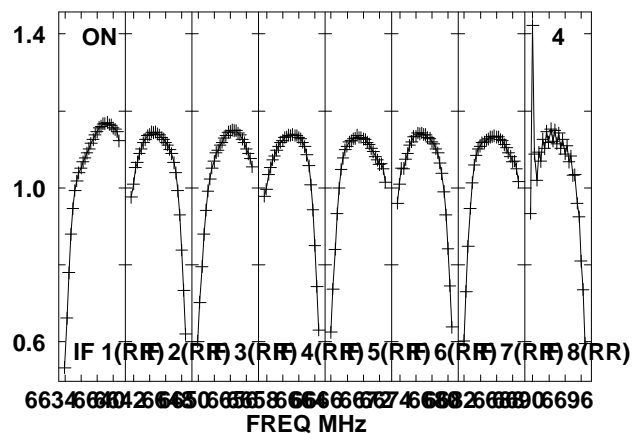
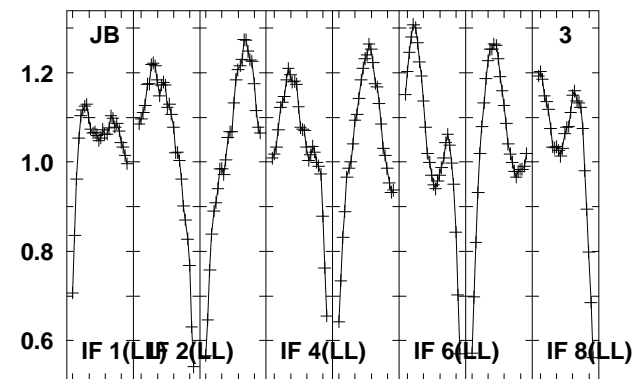
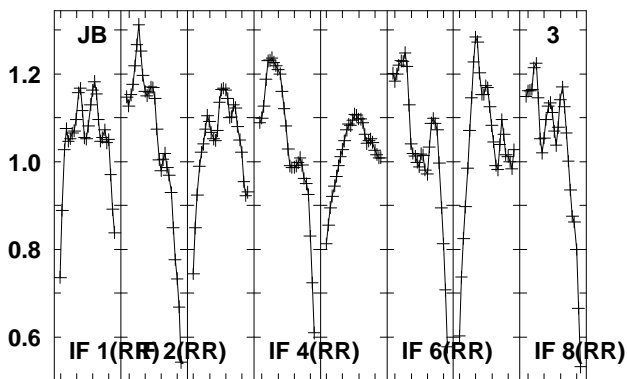
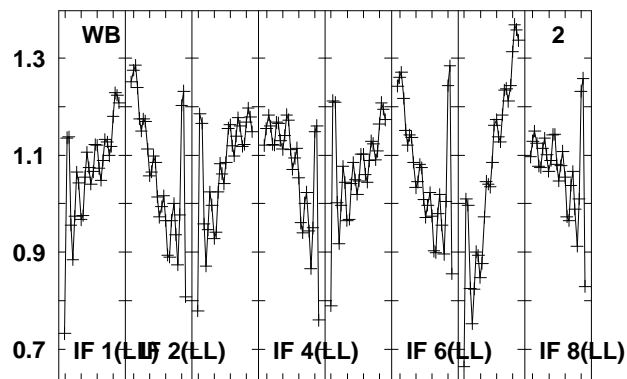
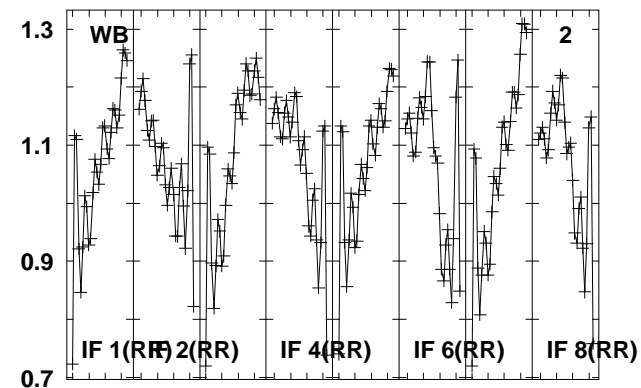
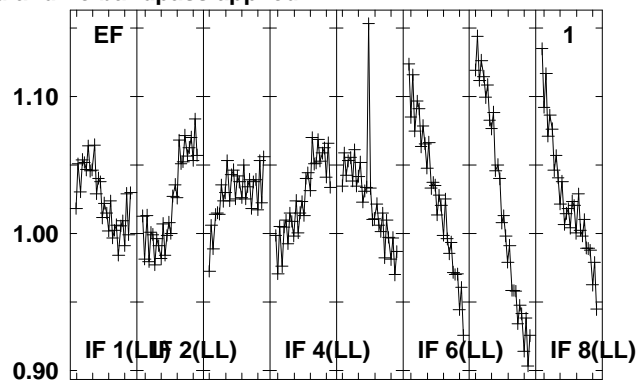
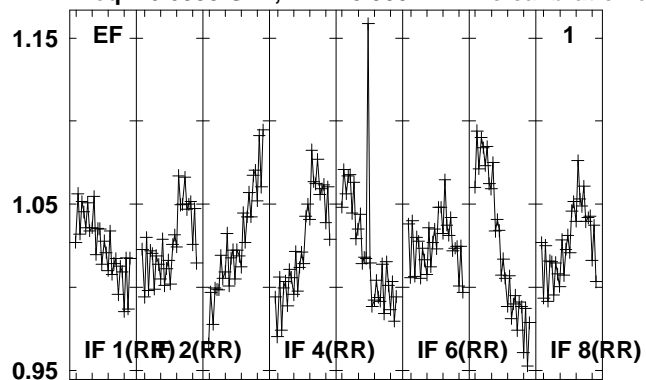

Lower frame: Real Jy
Total-power spectrum Antenna: *
Timerange: 00/13:45:00 to 00/13:46:28

Plot file version 156 created 15-MAR-2012 17:32:15

G85.40 EZ020E 2.UVDATA.1

Freq = 6.6335 GHz, Bw = 8.000 MH No calibration applied and no bandpass applied

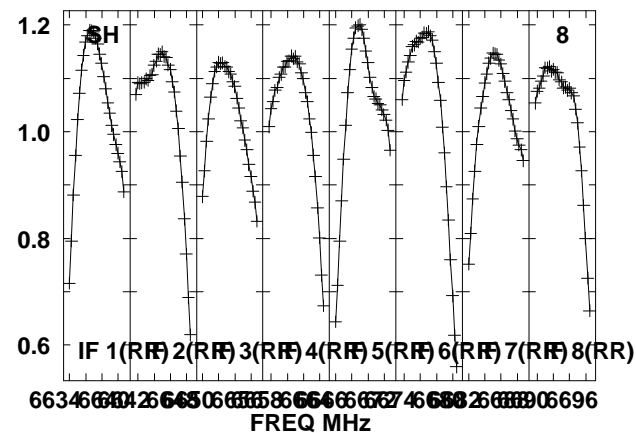
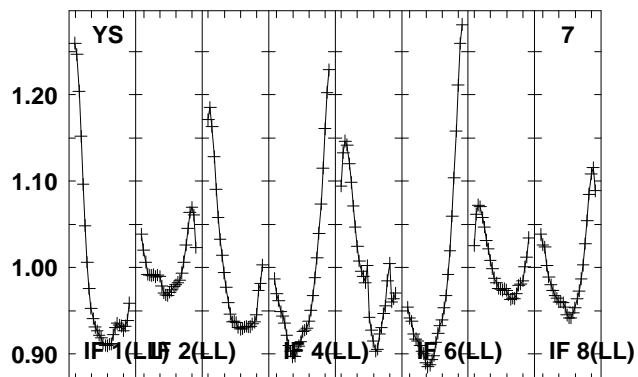
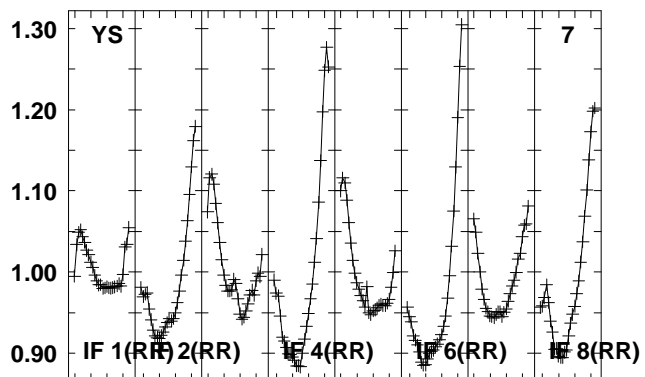
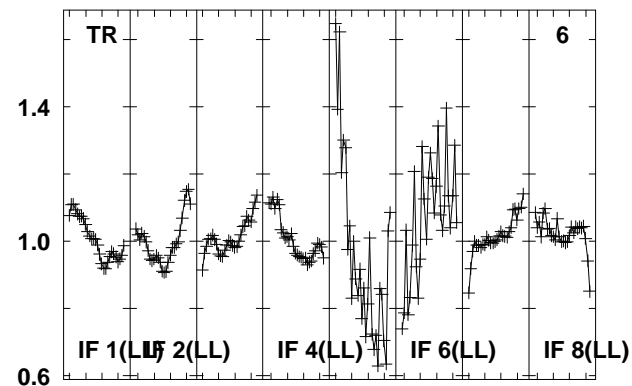
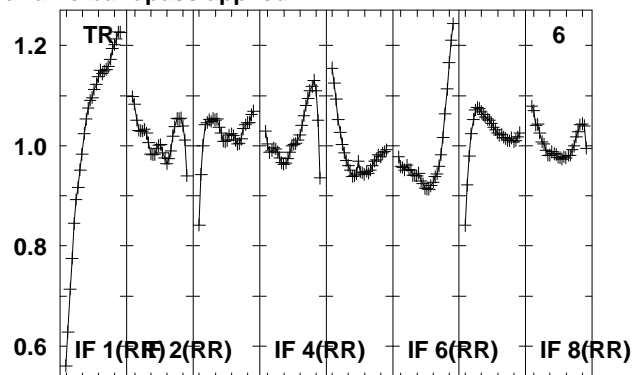
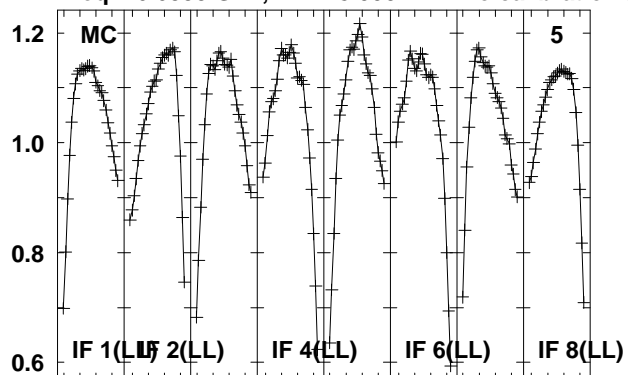

Plot file version 157 created 15-MAR-2012 17:32:17

2102-G85 EZ020E 2.UVDATA.1

Freq = 6.6335 GHz, Bw = 8.000 MH No calibration applied and no bandpass applied

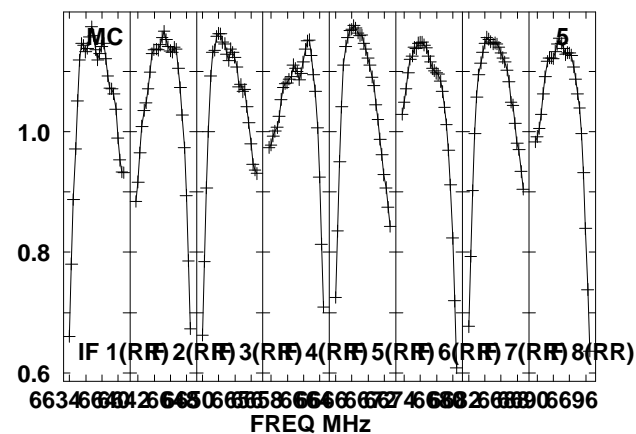
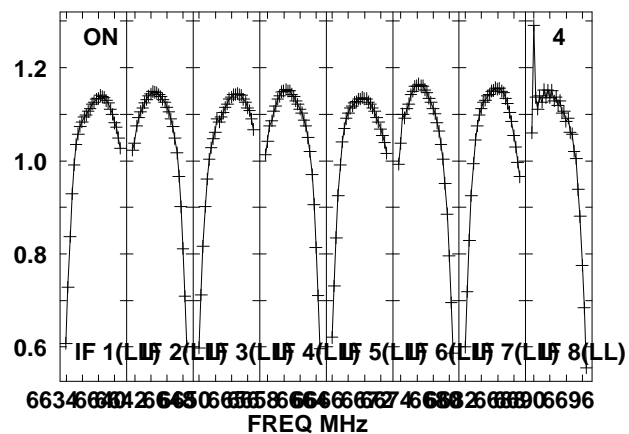
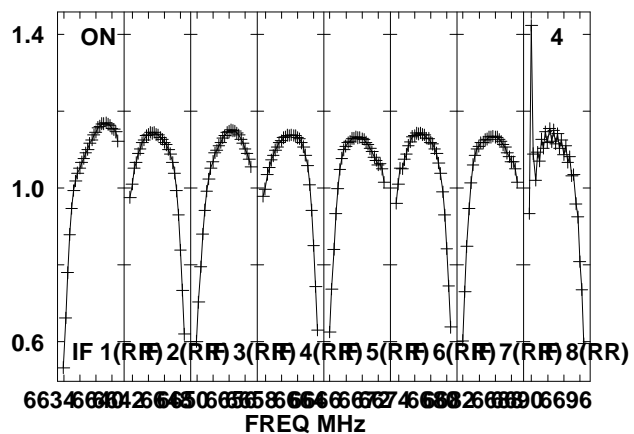
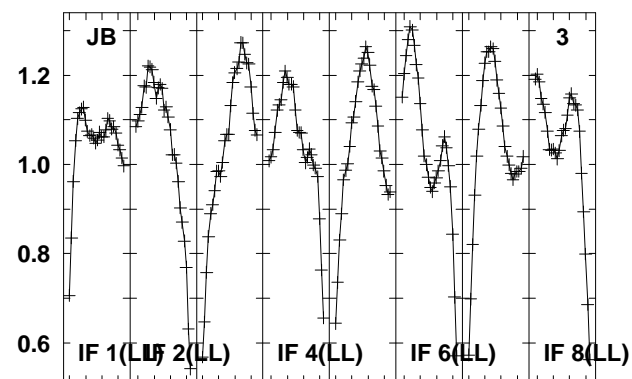
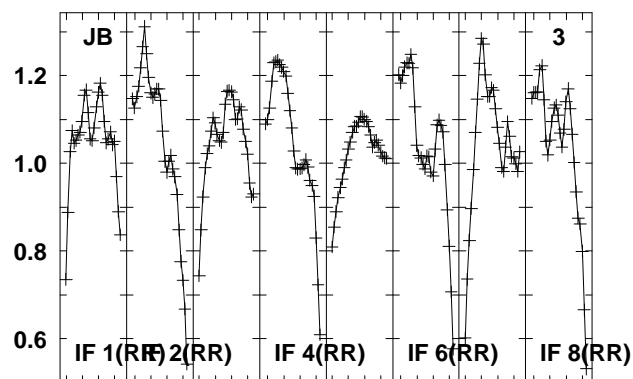
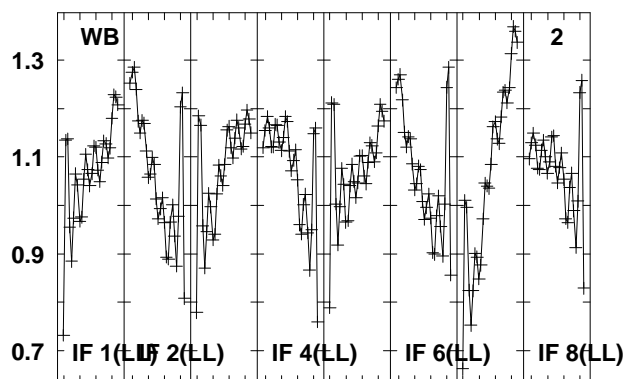
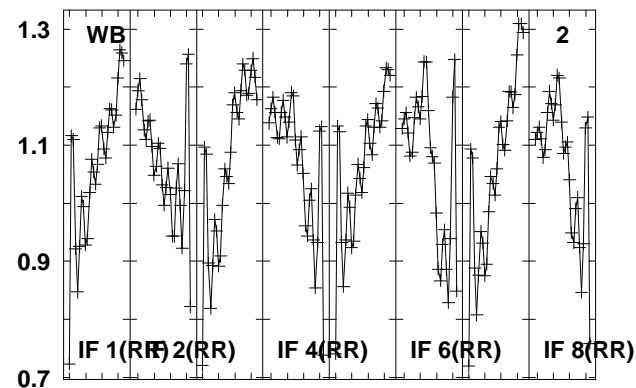
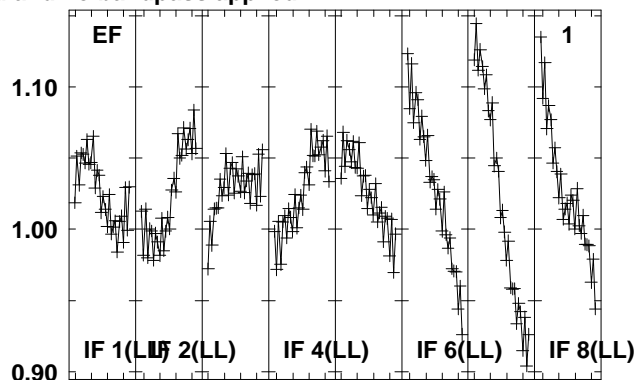
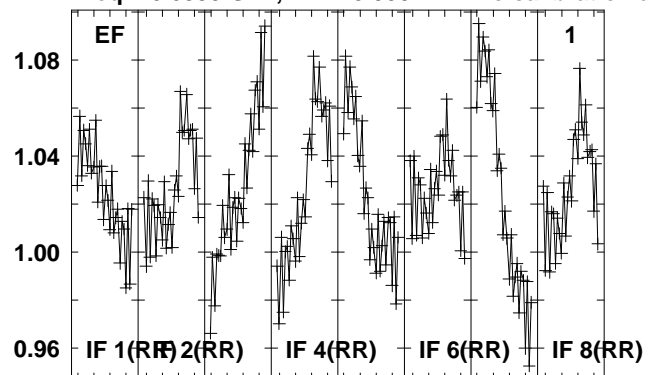

Lower frame: Real Jy
Total-power spectrum Antenna: *
Timerange: 00/13:46:30 to 00/13:47:58

Plot file version 158 created 15-MAR-2012 17:32:17

2102-G85 EZ020E 2.UVDATA.1

Freq = 6.6335 GHz, Bw = 8.000 MH No calibration applied and no bandpass applied

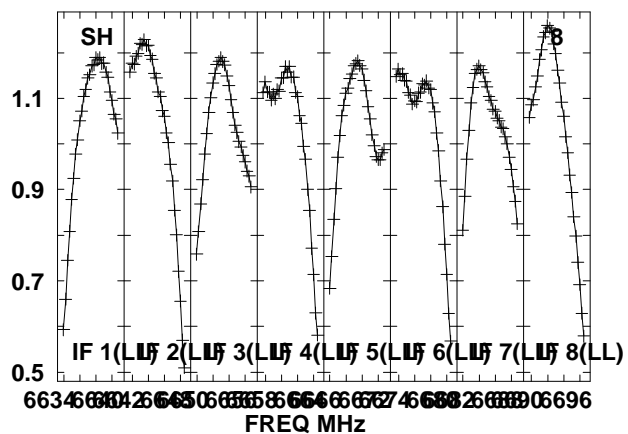
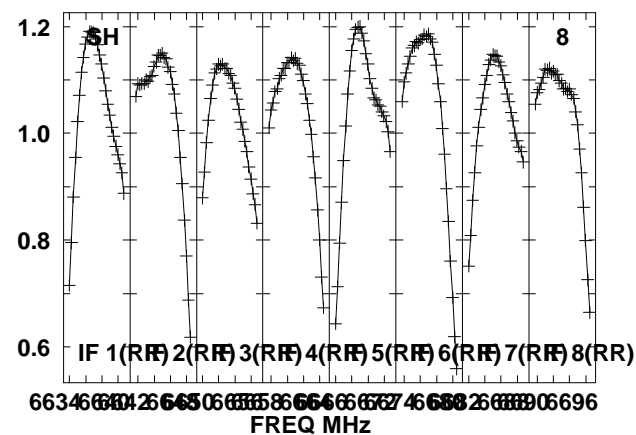
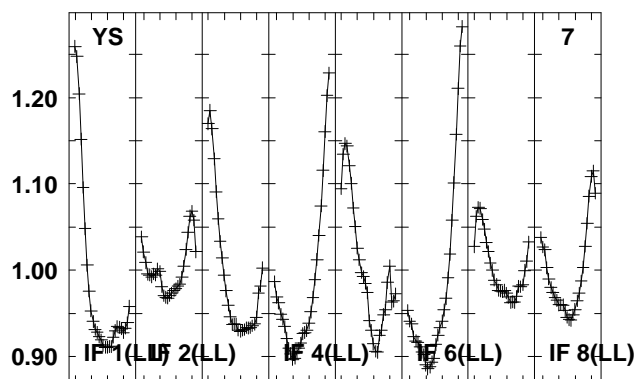
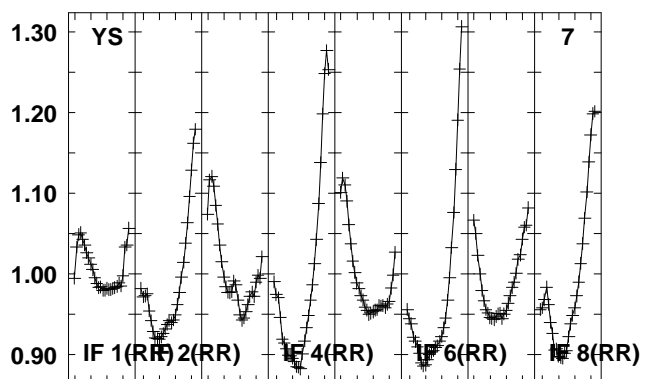
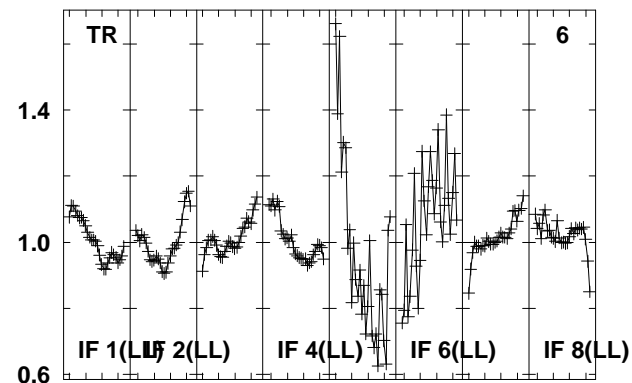
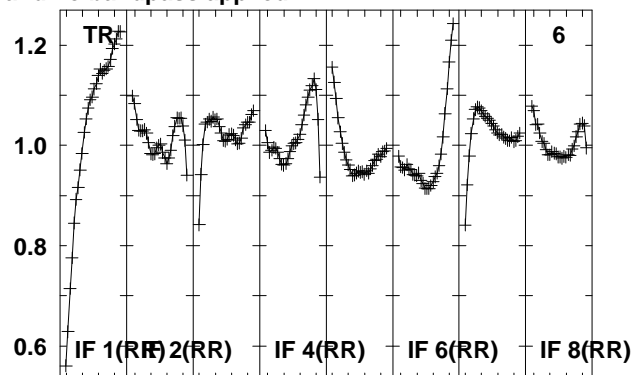
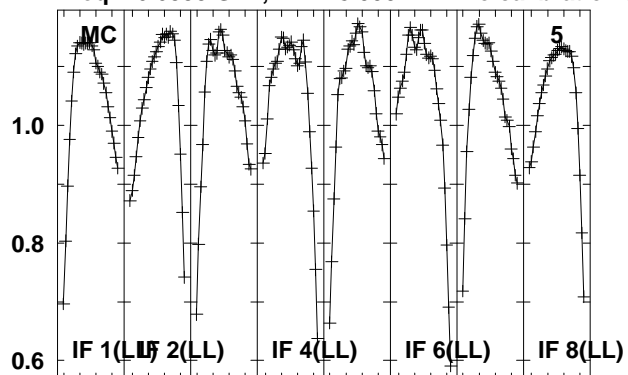

Lower frame: Real Jy

Total-power spectrum Antenna: *

Timerange: 00/13:46:30 to 00/13:47:58

Plot file version 159 created 15-MAR-2012 17:32:19

G85.40 EZ020E 2.UVDATA.1

Freq = 6.6335 GHz, Bw = 8.000 MH No calibration applied and no bandpass applied

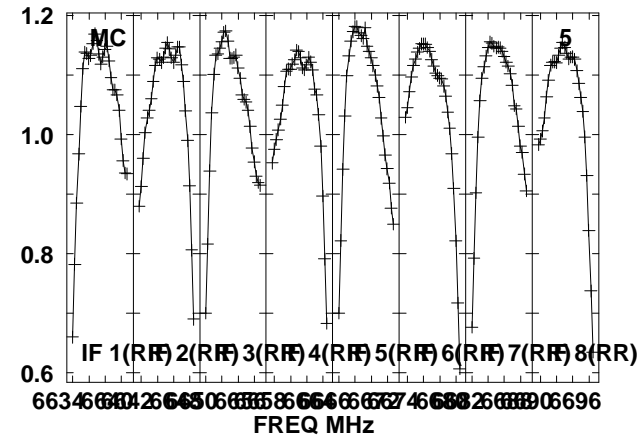
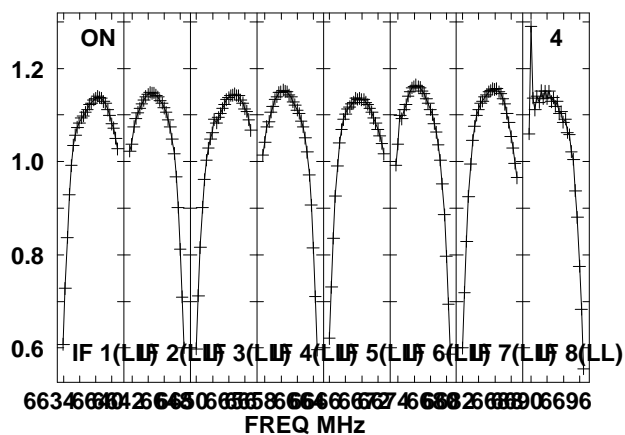
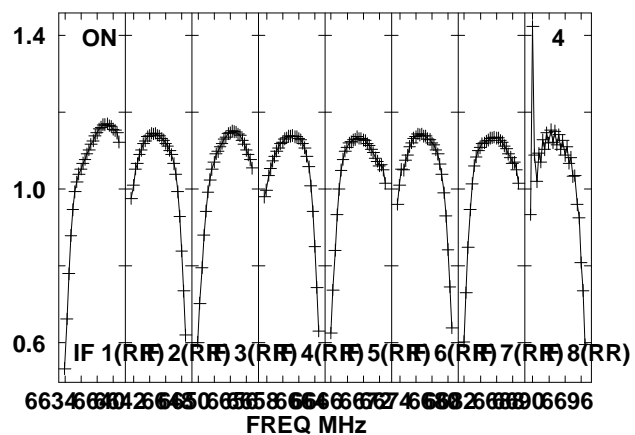
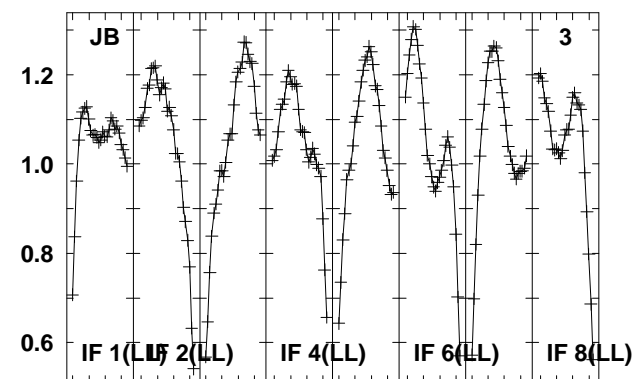
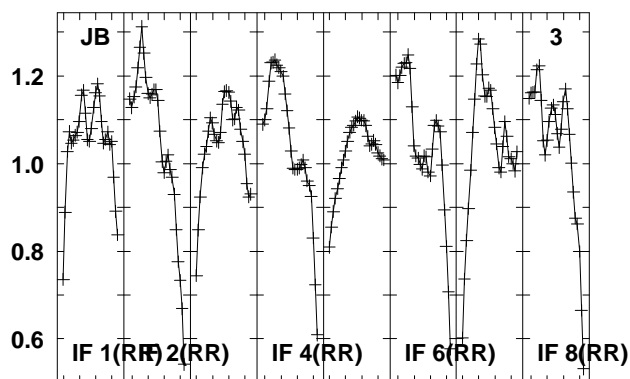
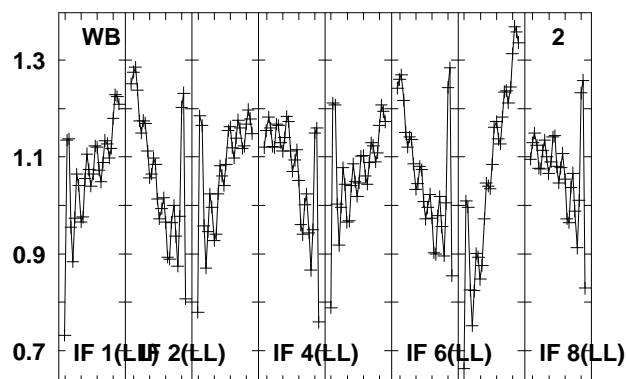
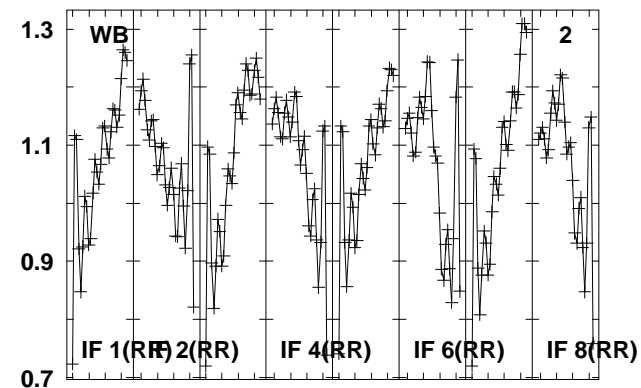
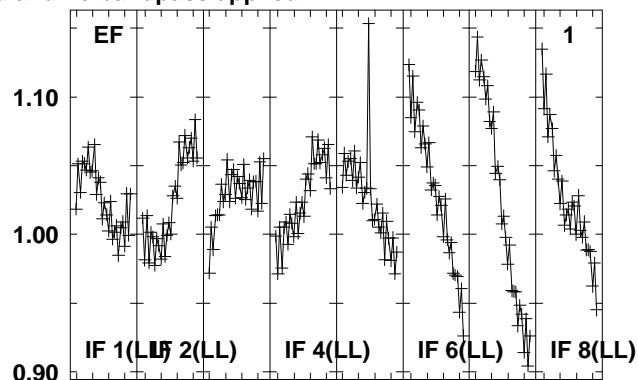
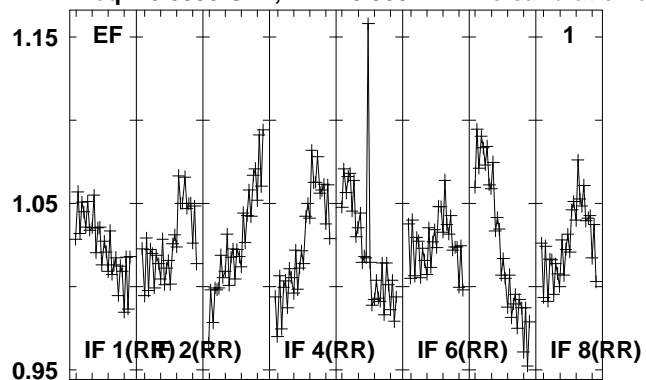

Lower frame: Real Jy
Total-power spectrum Antenna: *
Timerange: 00/13:47:59 to 00/13:49:27

Plot file version 160 created 15-MAR-2012 17:32:20

G85.40 EZ020E 2.UVDATA.1

Freq = 6.6335 GHz, Bw = 8.000 MH No calibration applied and no bandpass applied

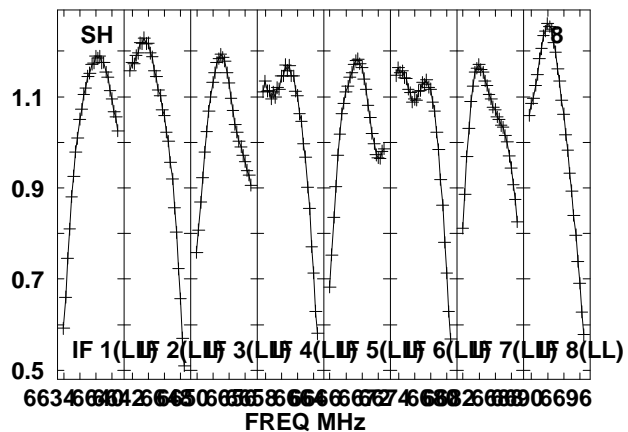
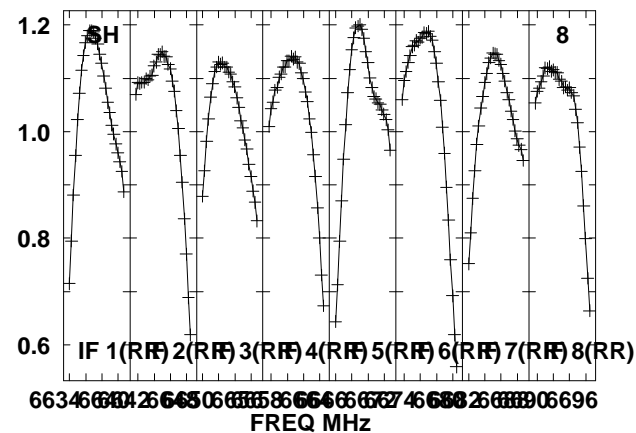
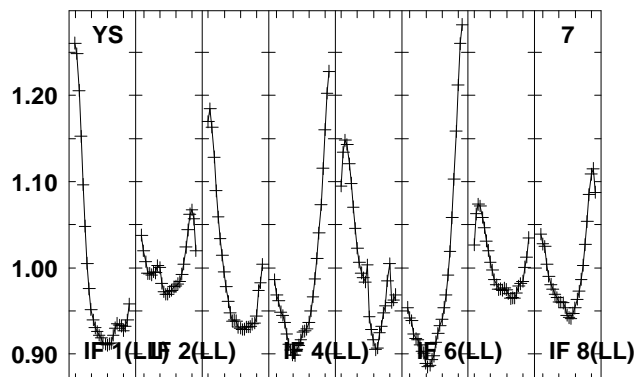
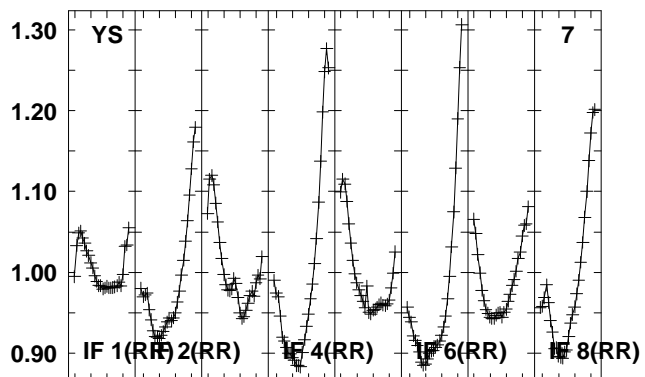
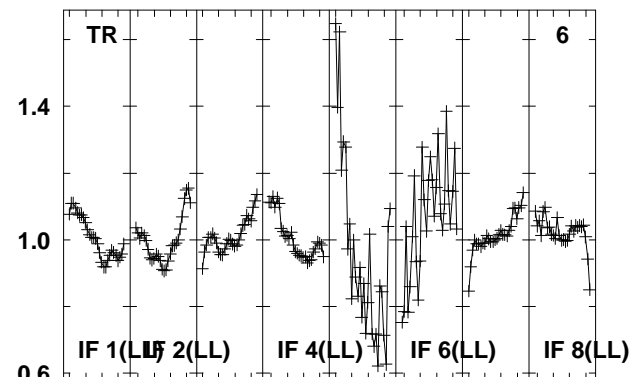
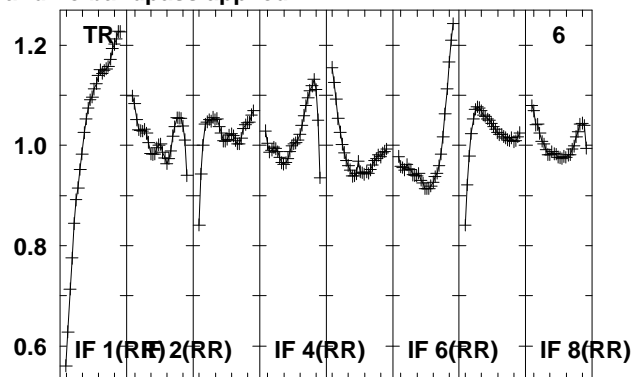
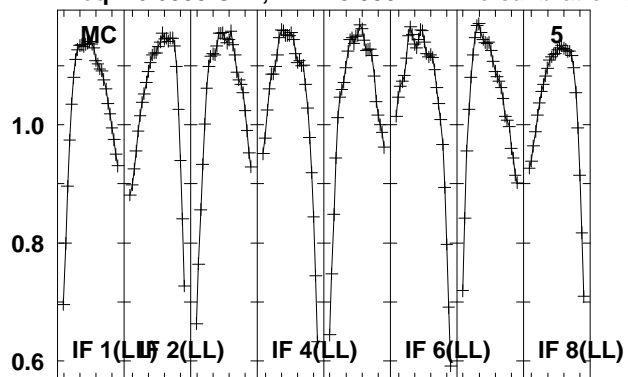

Lower frame: Real Jy

Total-power spectrum Antenna: *

Timerange: 00/13:47:59 to 00/13:49:27

Plot file version 161 created 15-MAR-2012 17:32:21
 2114-G85 EZ020E 2.UVDATA.1
 Freq = 6.6335 GHz, Bw = 8.000 MH No calibration applied and no bandpass applied

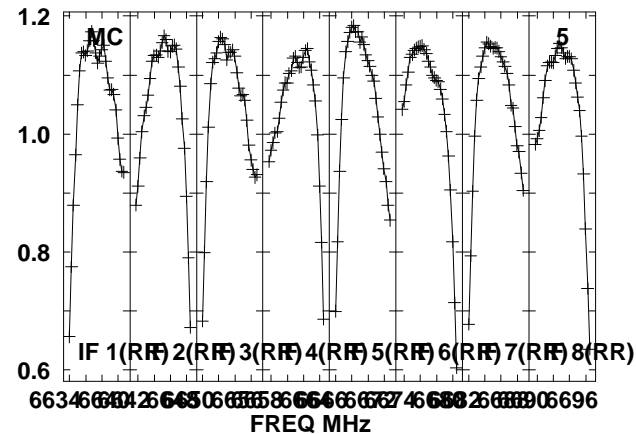
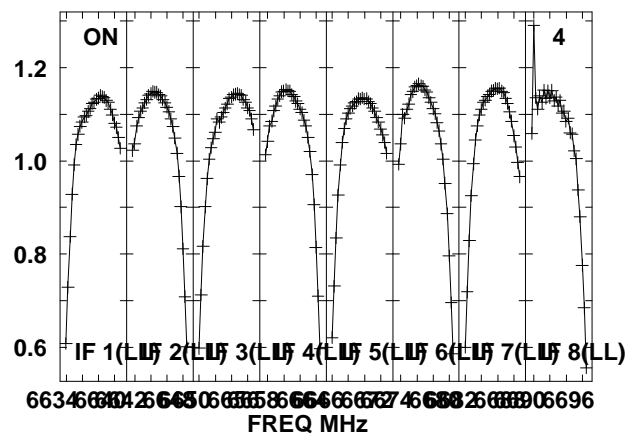
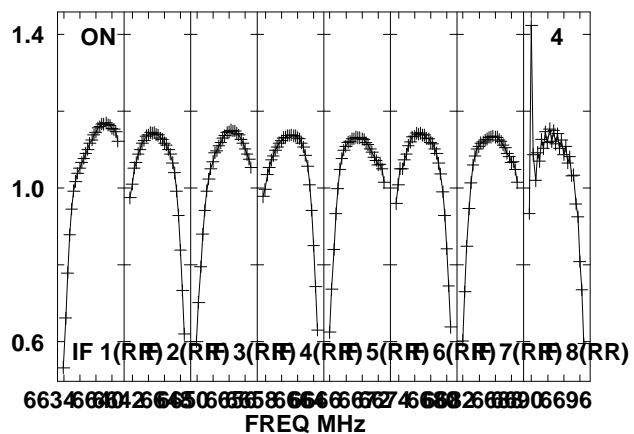
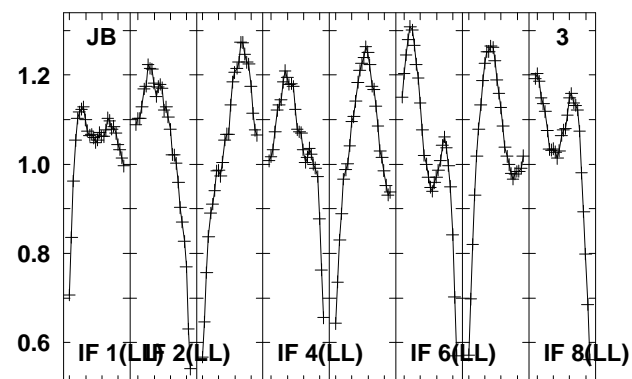
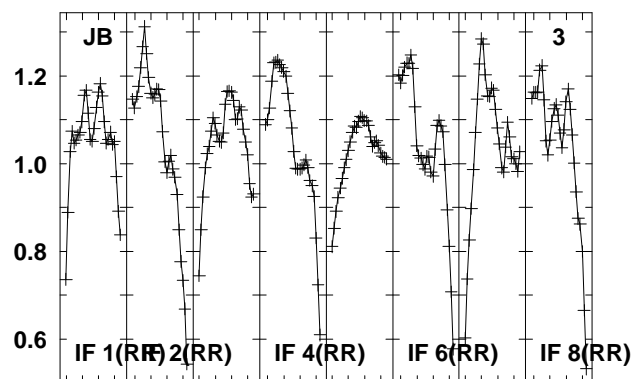
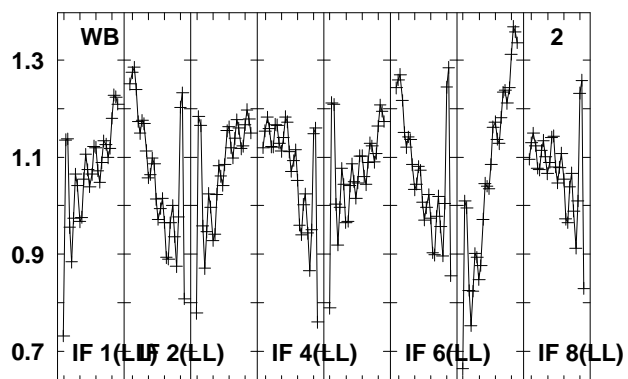
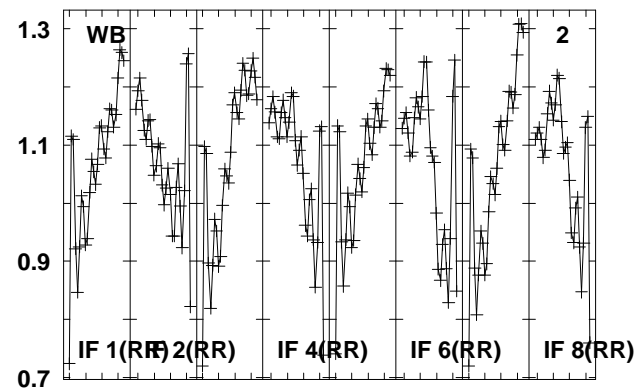
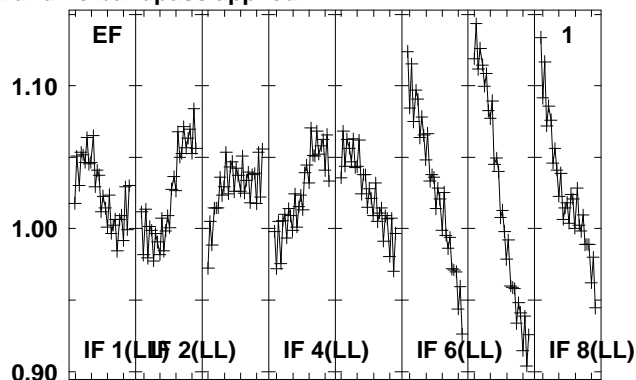
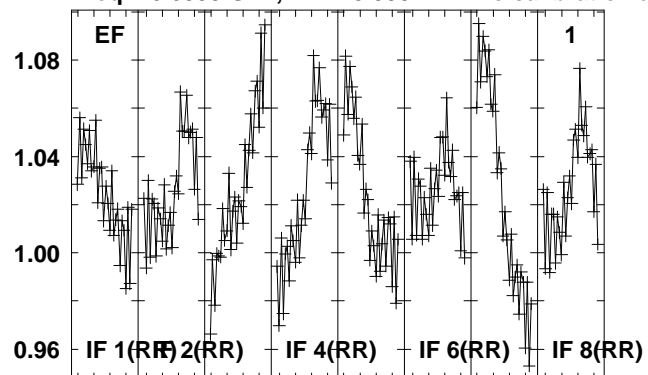

Lower frame: Real Jy
 Total-power spectrum Antenna: *
 Timerange: 00/13:49:29 to 00/13:50:57

Plot file version 162 created 15-MAR-2012 17:32:22

2114-G85 EZ020E 2.UVDATA.1

Freq = 6.6335 GHz, Bw = 8.000 MH No calibration applied and no bandpass applied

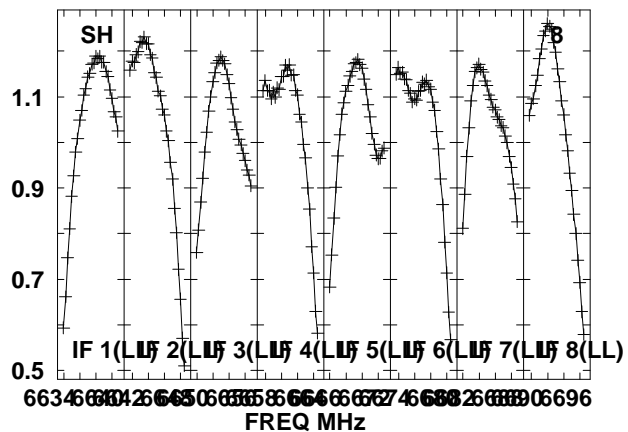
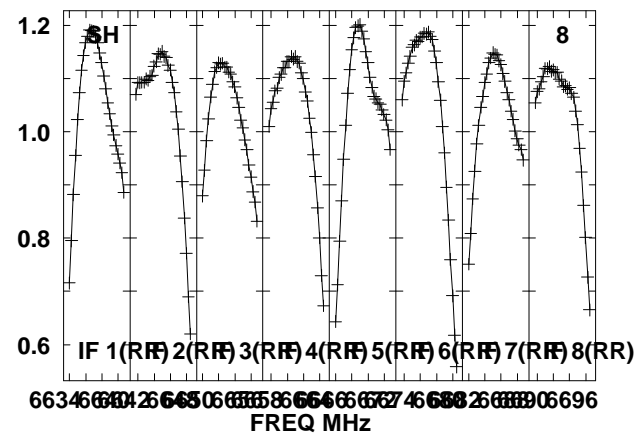
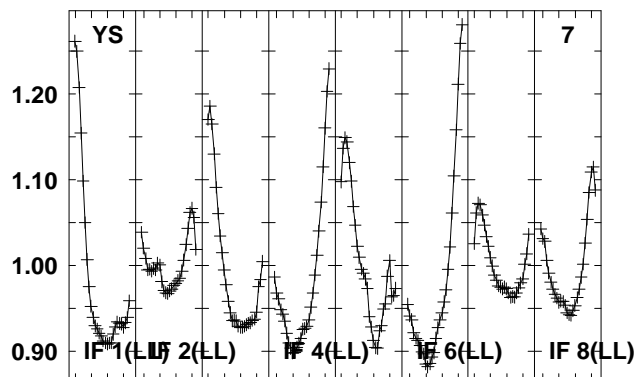
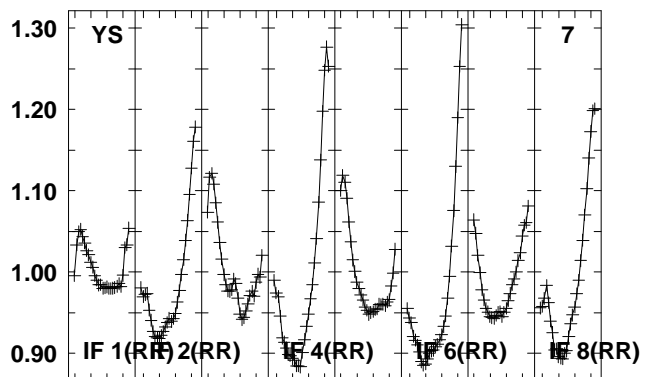
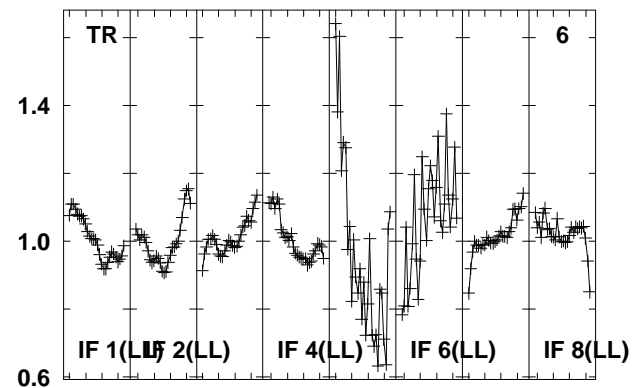
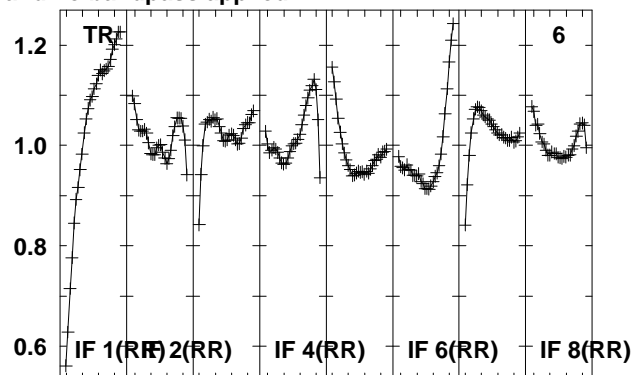
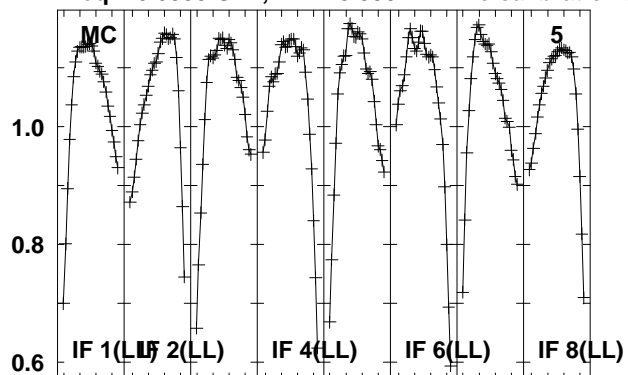

Lower frame: Real Jy

Total-power spectrum Antenna: *

Timerange: 00/13:49:29 to 00/13:50:57

Plot file version 163 created 15-MAR-2012 17:32:23

G85.40 EZ020E 2.UVDATA.1

Freq = 6.6335 GHz, Bw = 8.000 MH No calibration applied and no bandpass applied

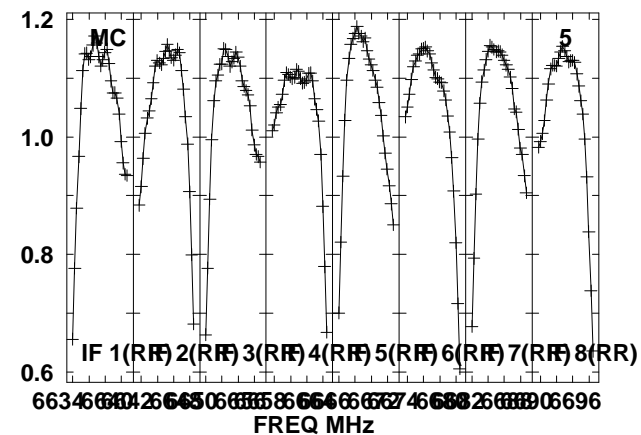
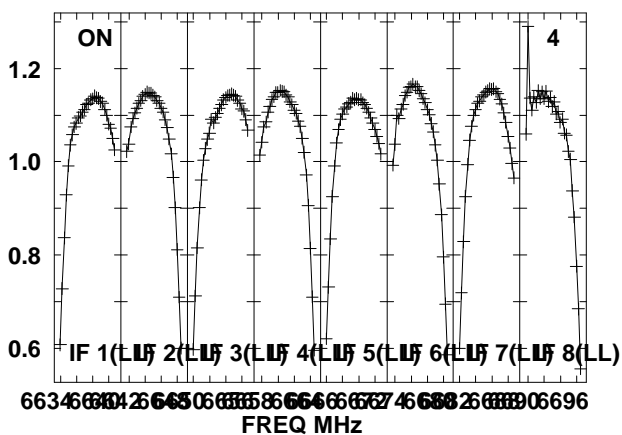
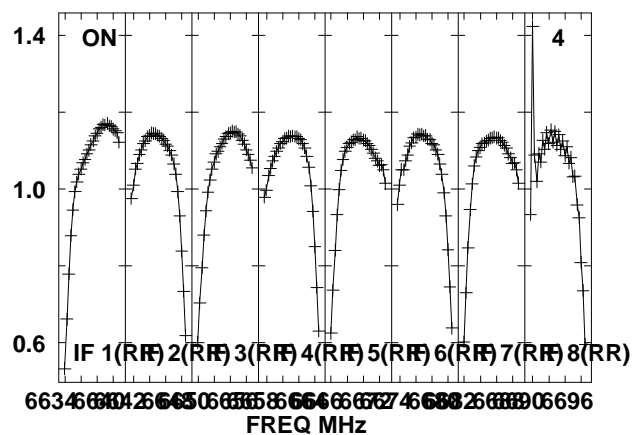
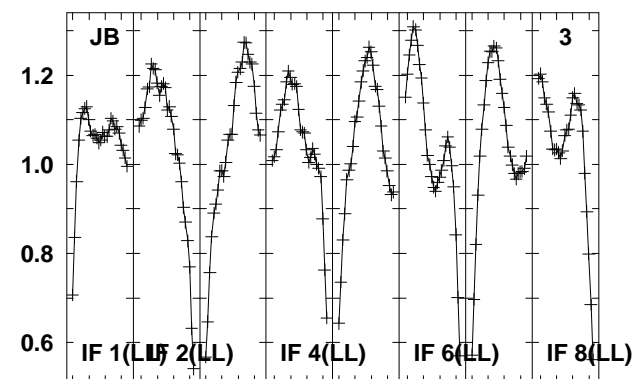
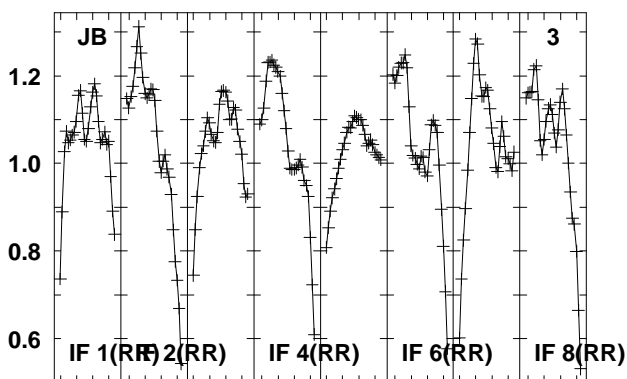
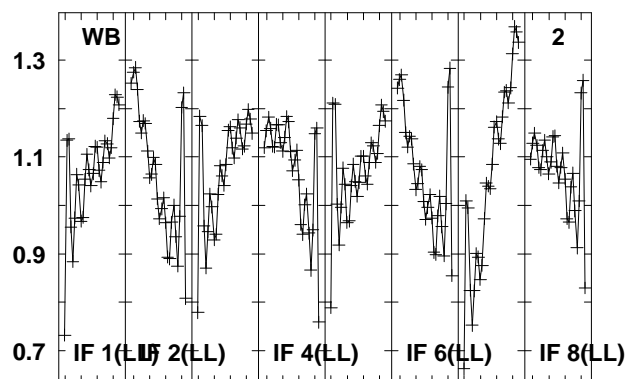
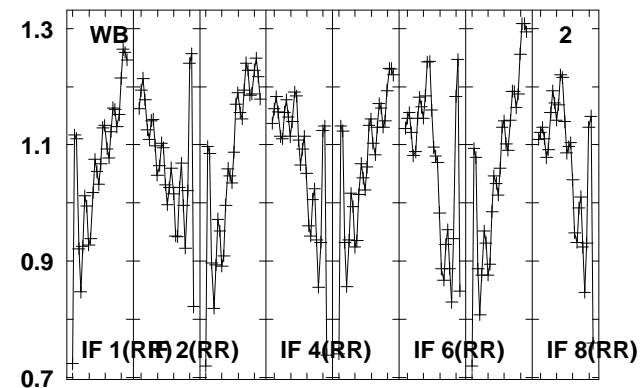
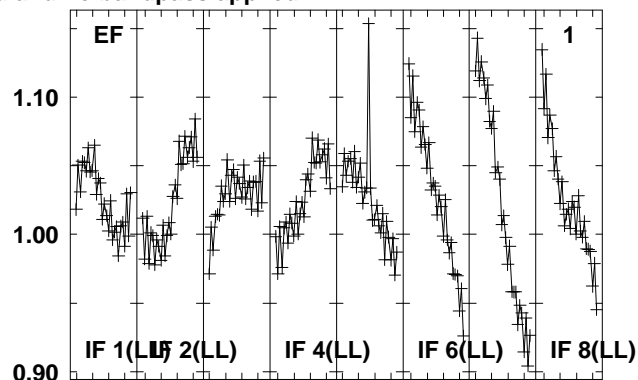
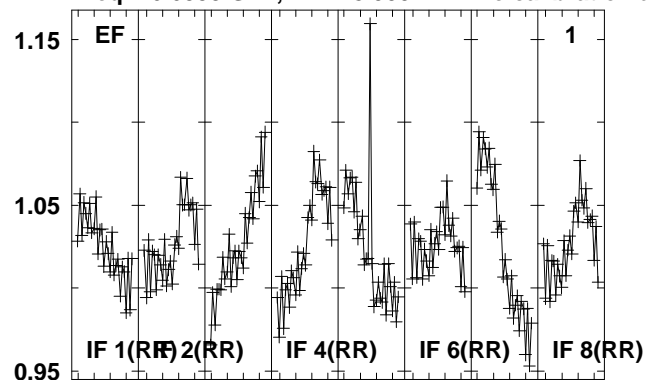

Lower frame: Real Jy
Total-power spectrum Antenna: *
Timerange: 00/13:51:00 to 00/13:52:28

Plot file version 164 created 15-MAR-2012 17:32:23

G85.40 EZ020E 2.UVDATA.1

Freq = 6.6335 GHz, Bw = 8.000 MH No calibration applied and no bandpass applied

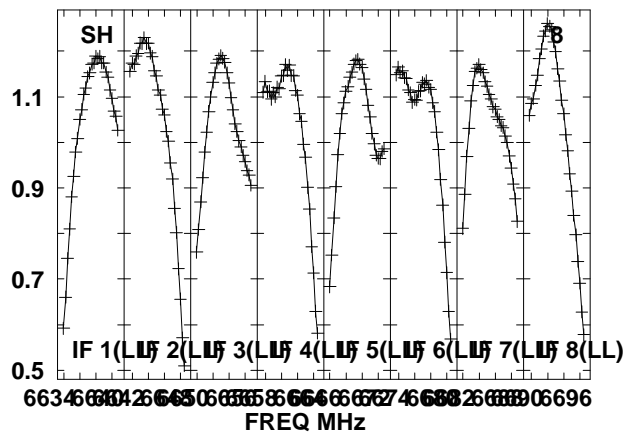
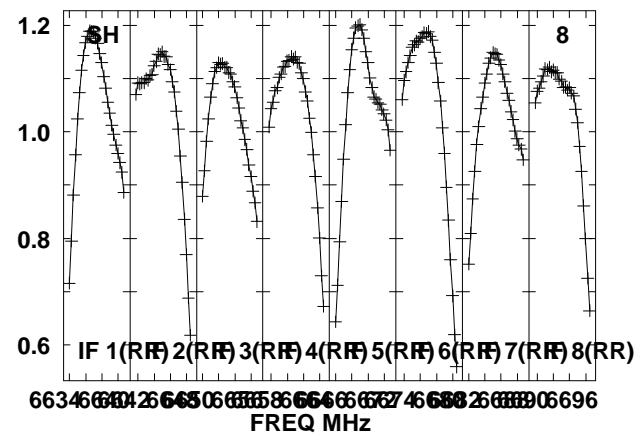
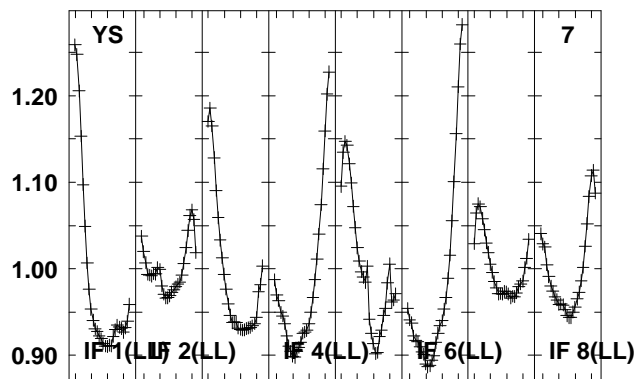
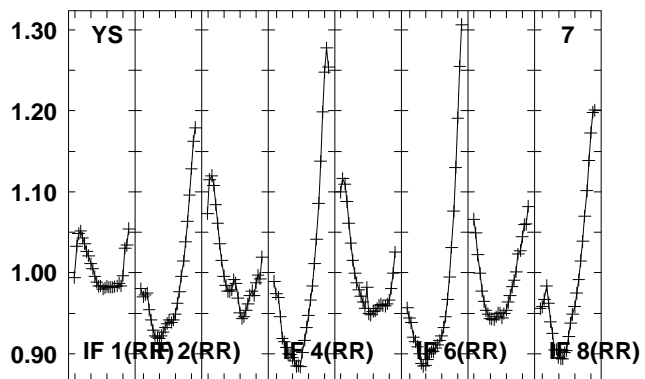
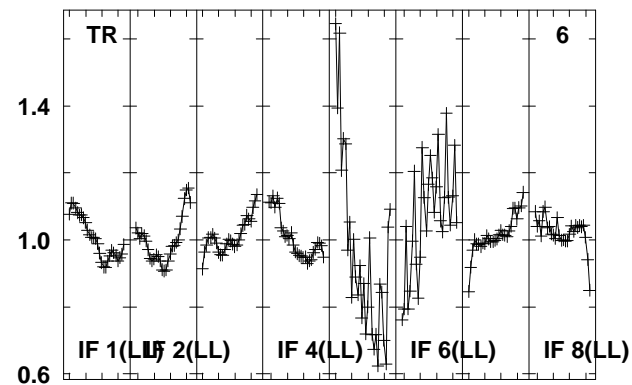
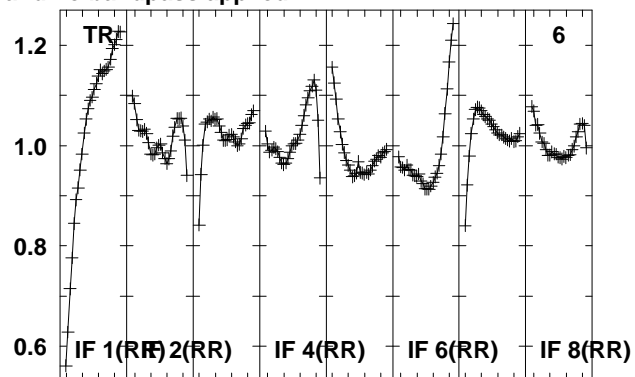
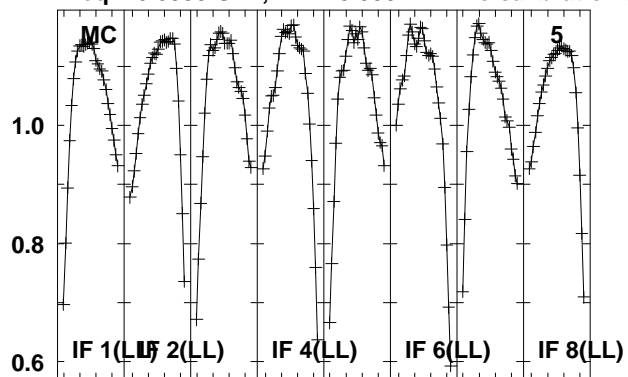

Lower frame: Real Jy
Total-power spectrum Antenna: *
Timerange: 00/13:51:00 to 00/13:52:28

Plot file version 165 created 15-MAR-2012 17:32:24
 2102-G85 EZ020E 2.UVDATA.1
 Freq = 6.6335 GHz, Bw = 8.000 MH No calibration applied and no bandpass applied

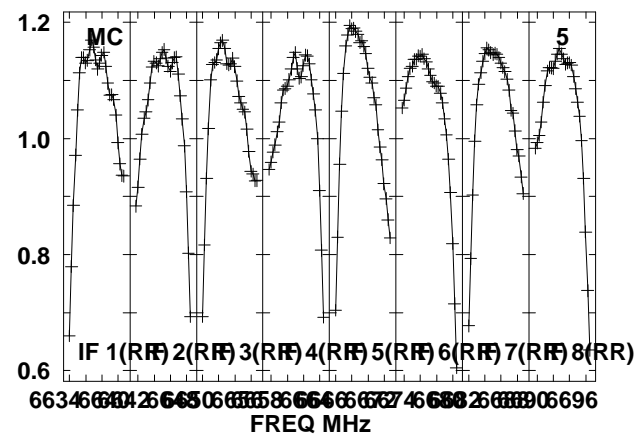
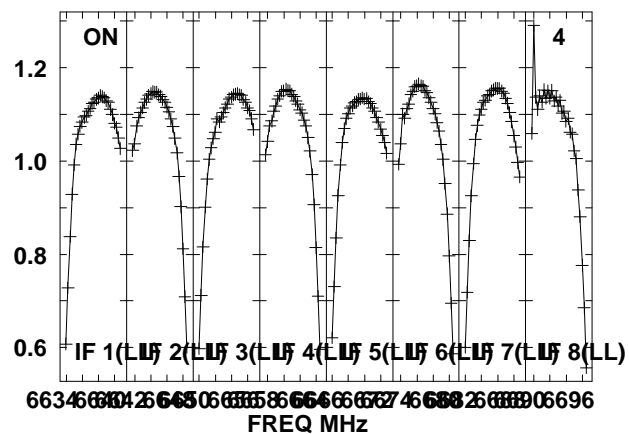
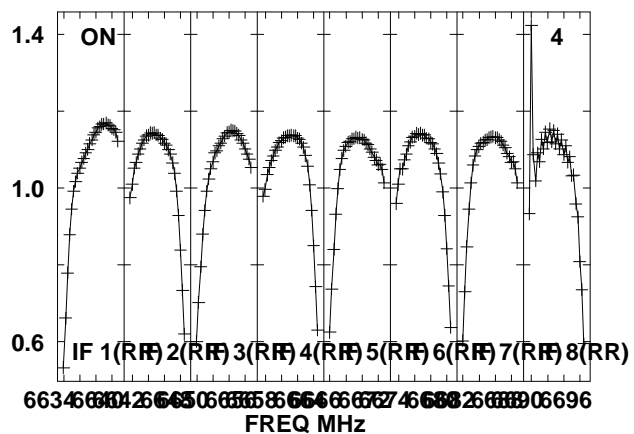
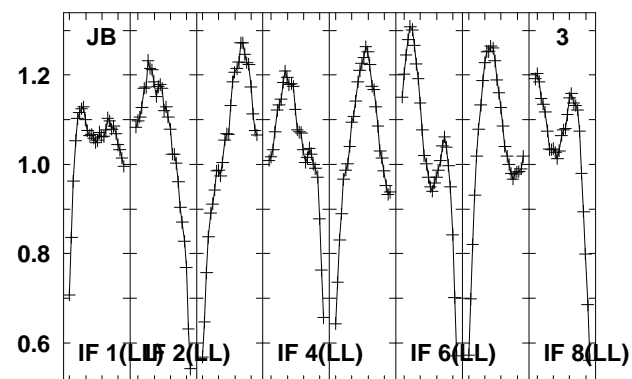
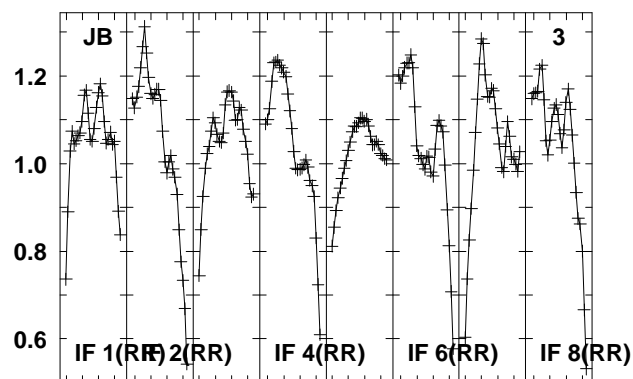
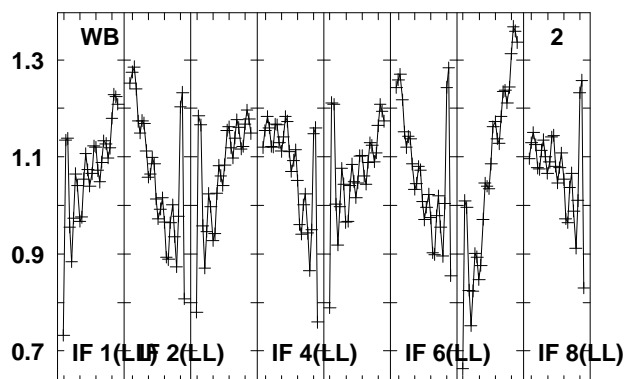
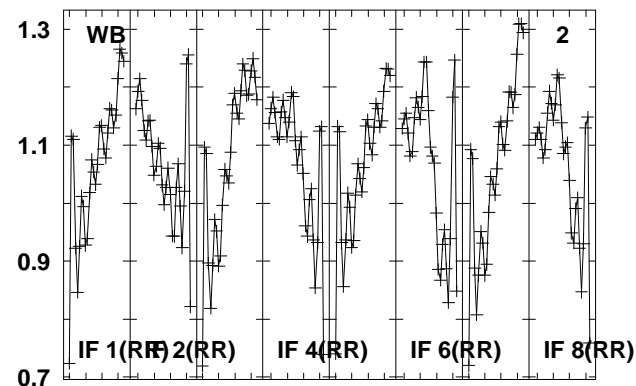
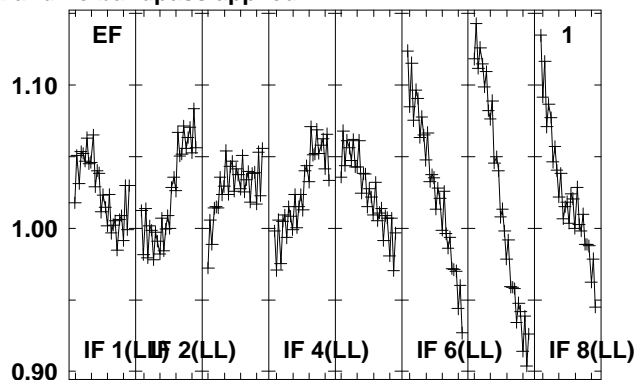
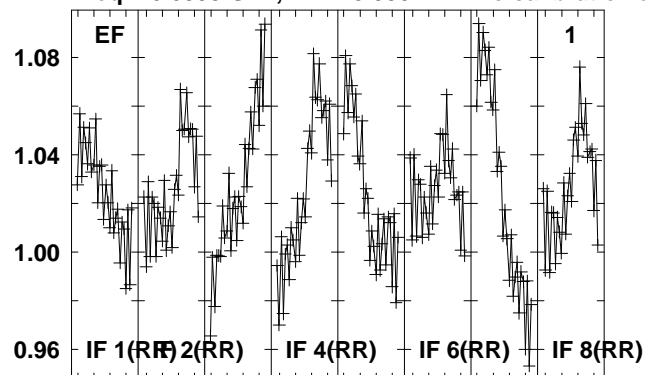

Lower frame: Real Jy
 Total-power spectrum Antenna: *
 Timerange: 00/13:52:30 to 00/13:53:58

Plot file version 166 created 15-MAR-2012 17:32:25

2102-G85 EZ020E 2.UVDATA.1

Freq = 6.6335 GHz, Bw = 8.000 MH No calibration applied and no bandpass applied

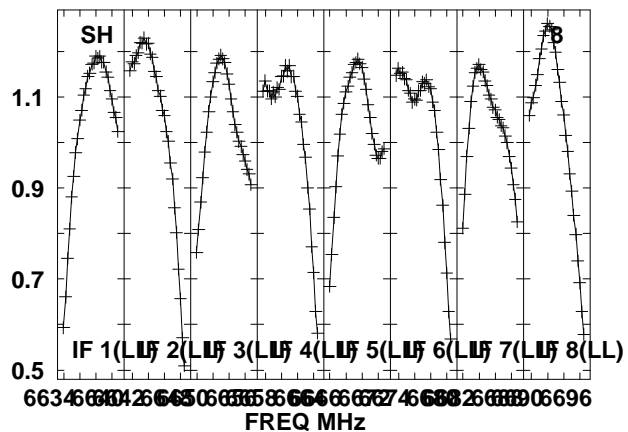
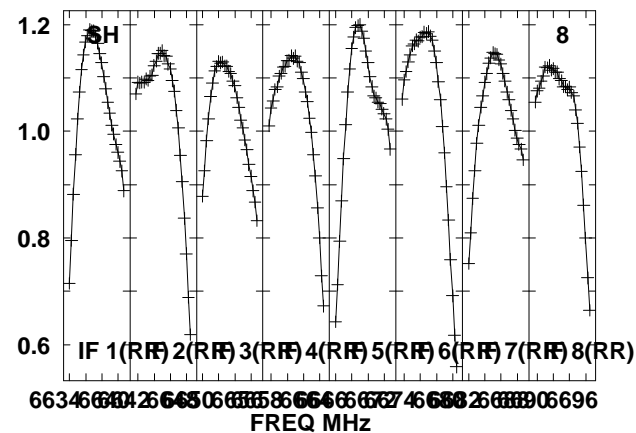
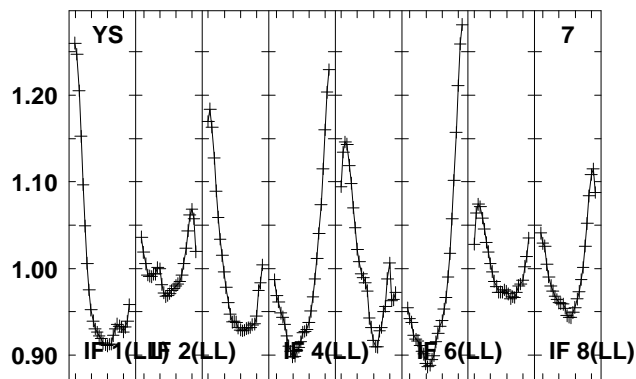
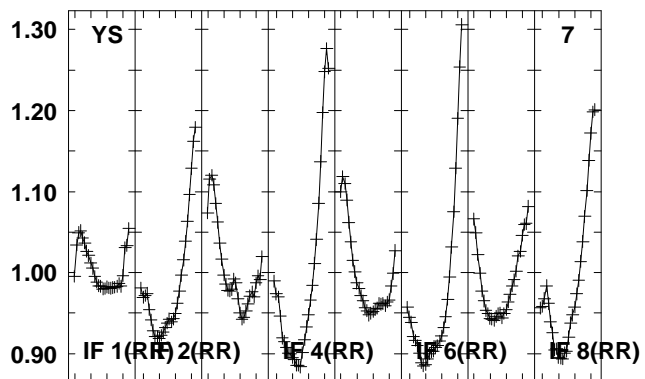
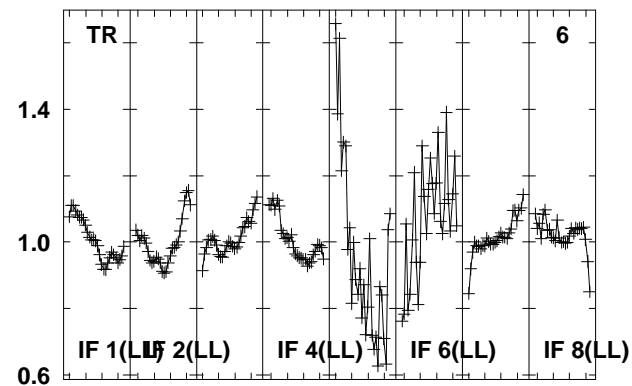
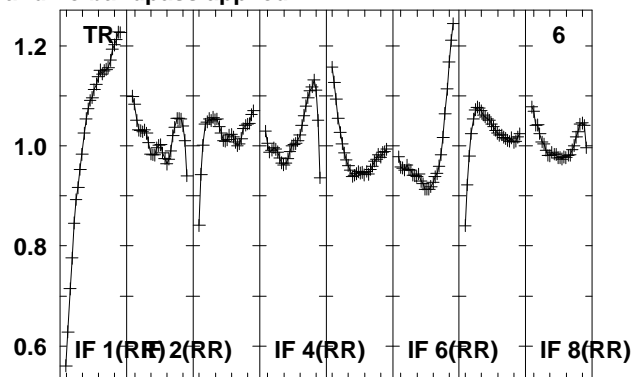
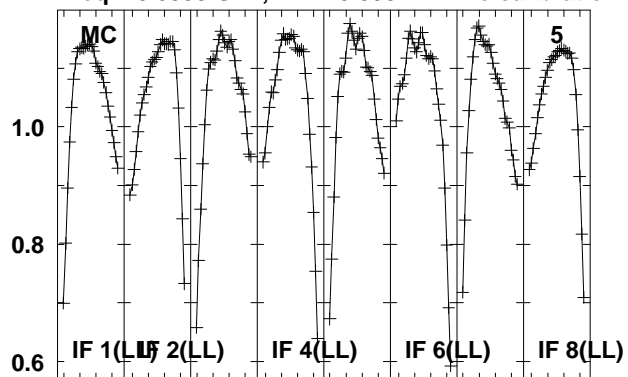

Lower frame: Real Jy
Total-power spectrum Antenna: *
Timerange: 00/13:52:30 to 00/13:53:58

Plot file version 167 created 15-MAR-2012 17:32:26

G85.40 EZ020E 2.UVDATA.1

Freq = 6.6335 GHz, Bw = 8.000 MH No calibration applied and no bandpass applied

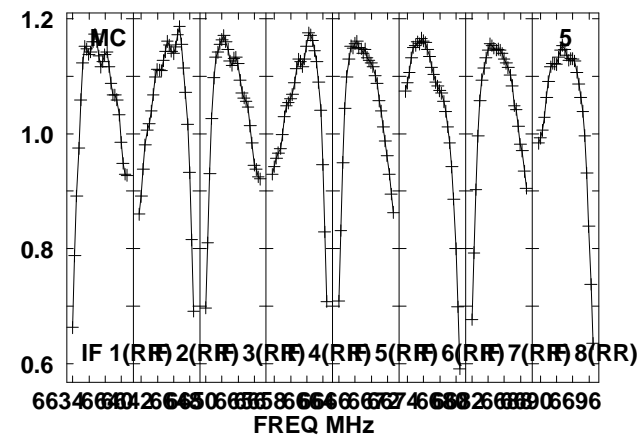
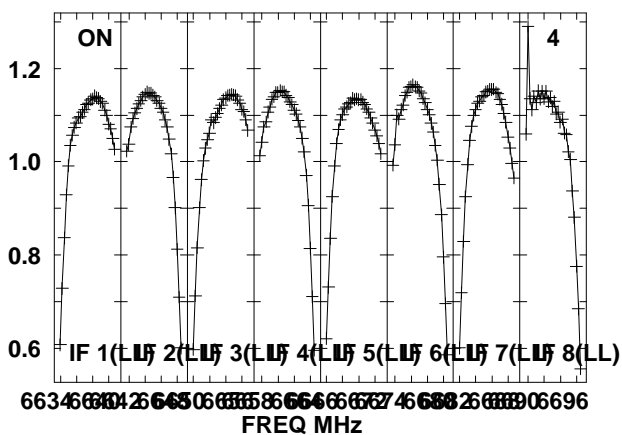
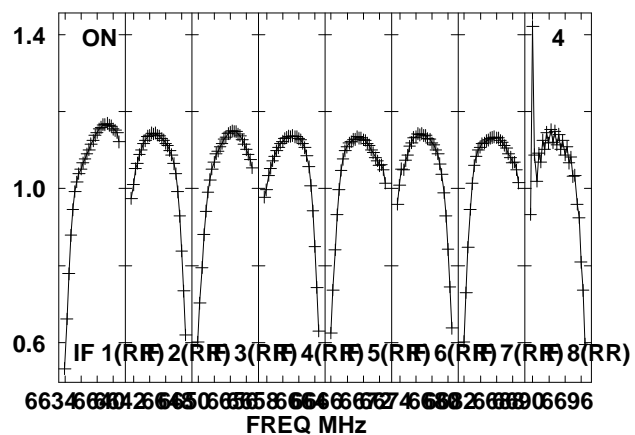
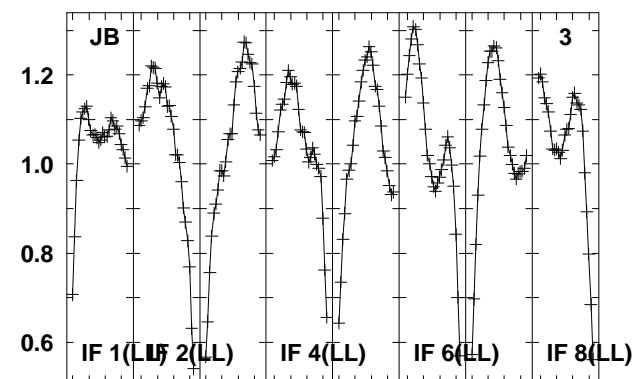
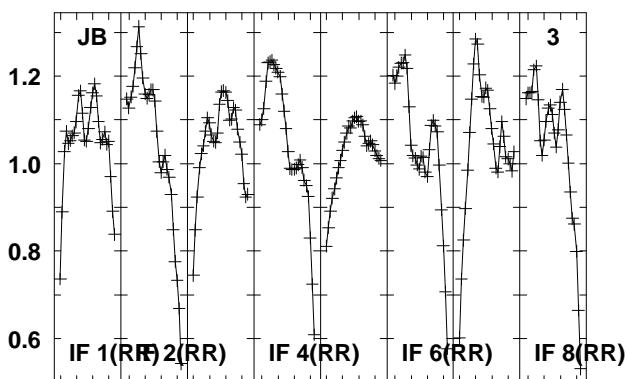
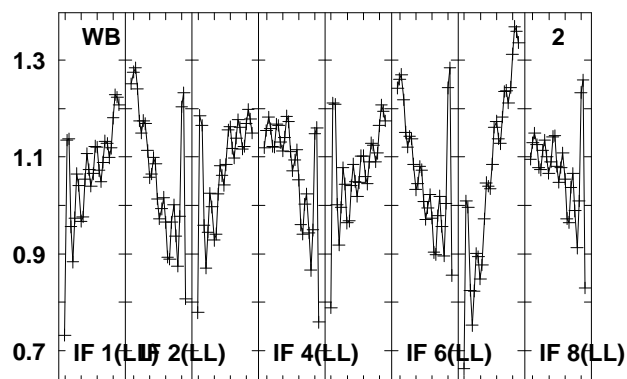
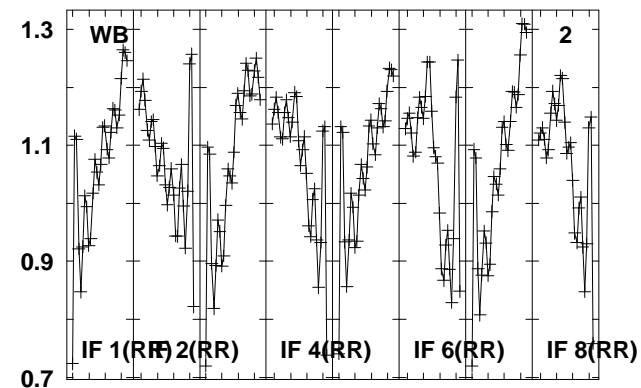
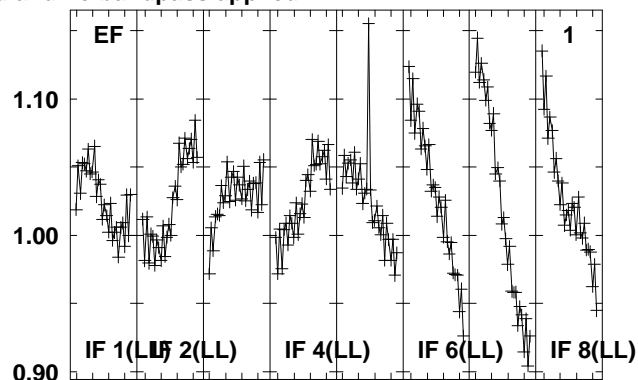
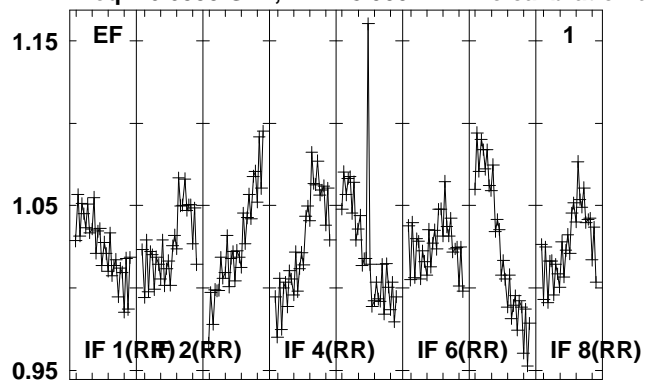

Lower frame: Real Jy
Total-power spectrum Antenna: *
Timerange: 00/13:53:59 to 00/13:55:27

Plot file version 168 created 15-MAR-2012 17:32:26

G85.40 EZ020E 2.UVDATA.1

Freq = 6.6335 GHz, Bw = 8.000 MH No calibration applied and no bandpass applied

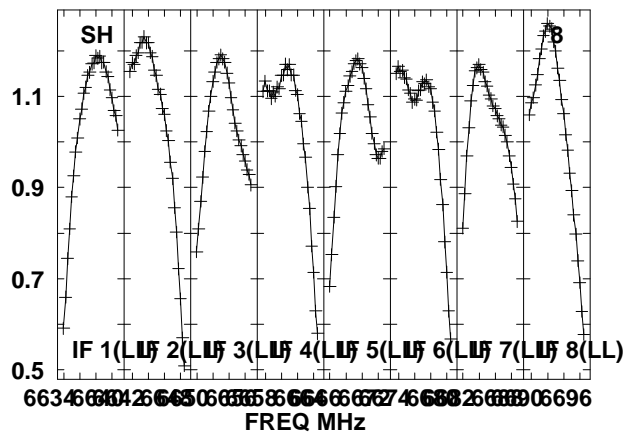
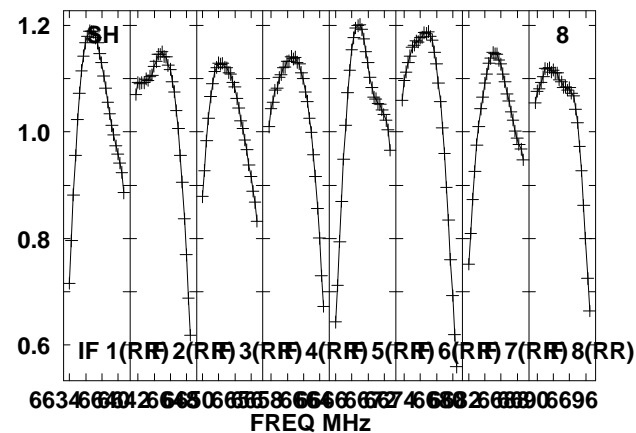
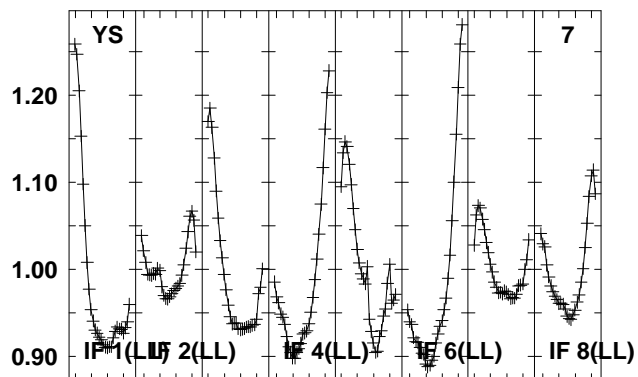
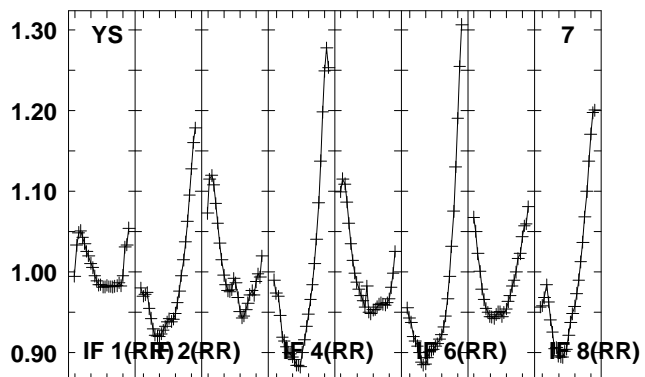
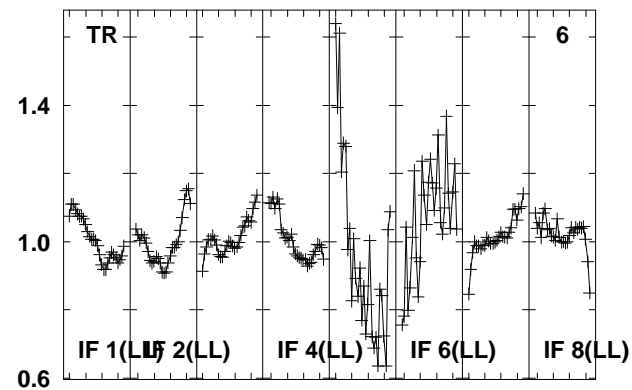
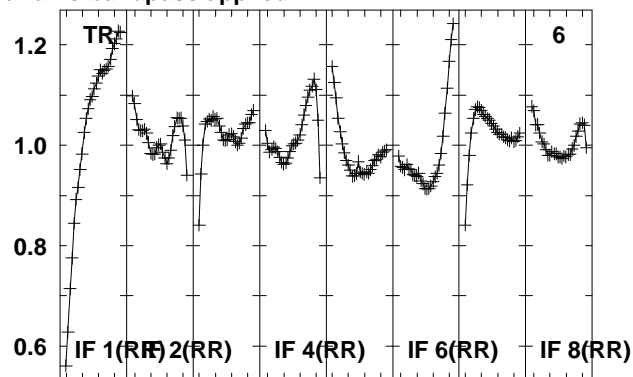
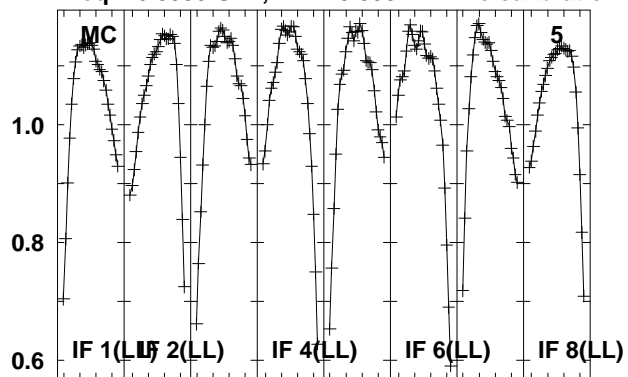

Lower frame: Real Jy

Total-power spectrum Antenna: *

Timerange: 00/13:53:59 to 00/13:55:27

Plot file version 169 created 15-MAR-2012 17:32:27

2114-G85 EZ020E 2.UVDATA.1

Freq = 6.6335 GHz, Bw = 8.000 MH No calibration applied and no bandpass applied

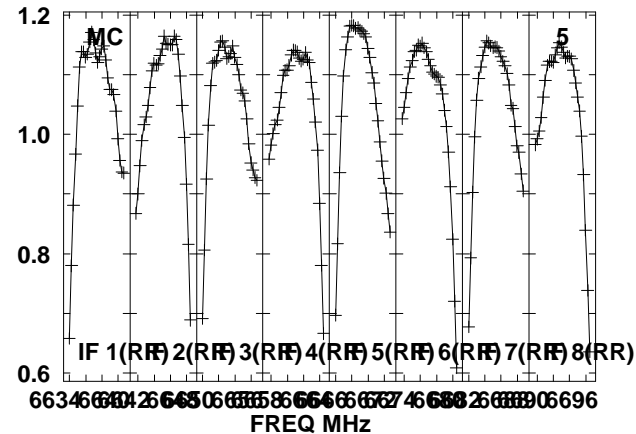
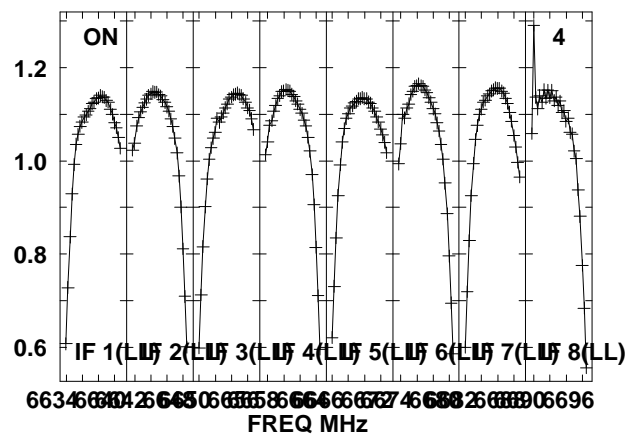
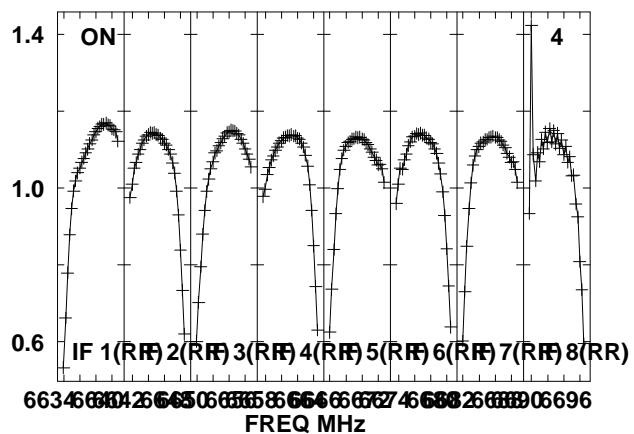
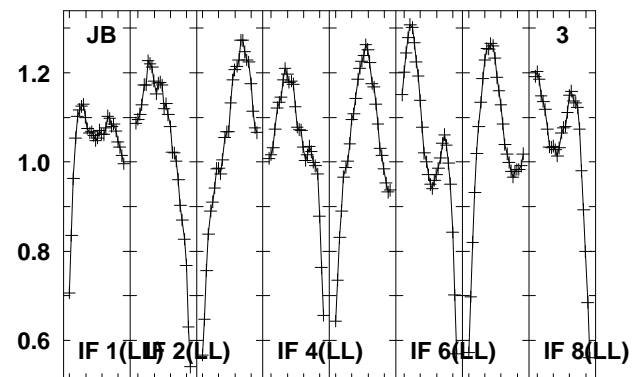
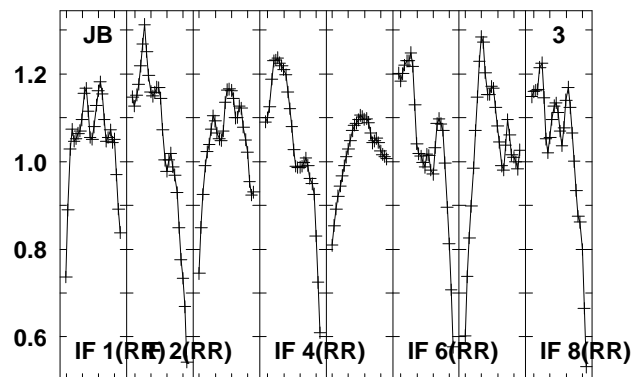
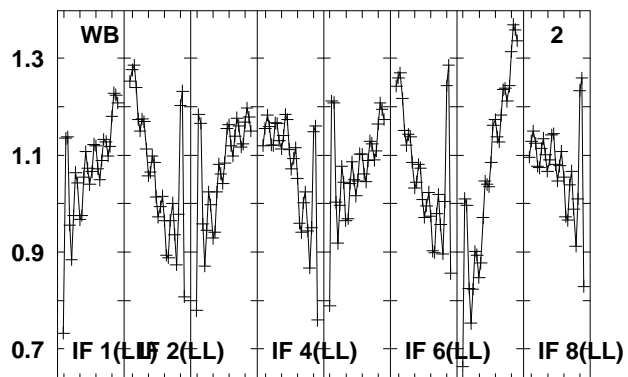
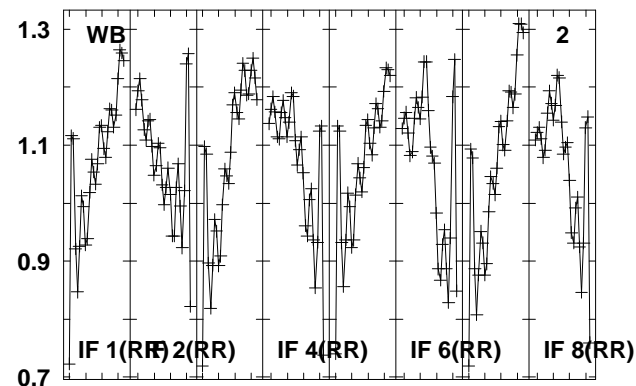
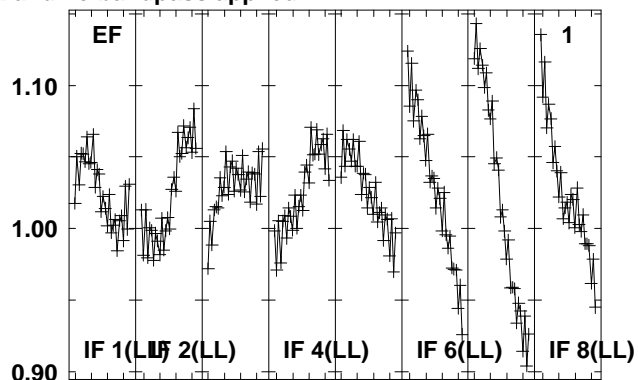
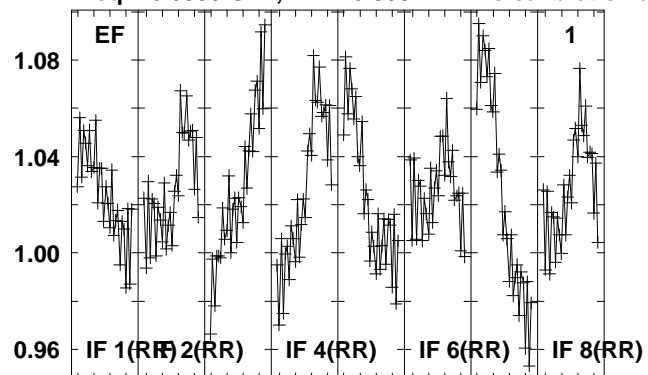

Lower frame: Real Jy
Total-power spectrum Antenna: *
Timerange: 00/13:55:29 to 00/13:56:57

Plot file version 170 created 15-MAR-2012 17:32:28

2114-G85 EZ020E 2.UVDATA.1

Freq = 6.6335 GHz, Bw = 8.000 MH No calibration applied and no bandpass applied

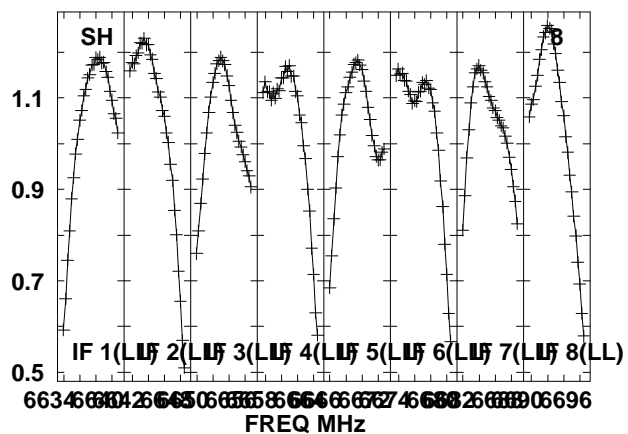
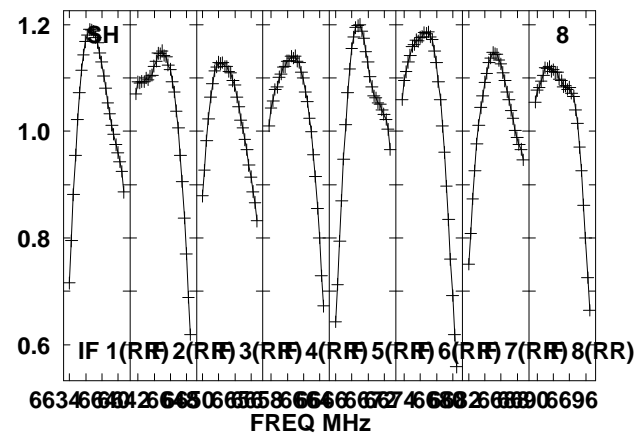
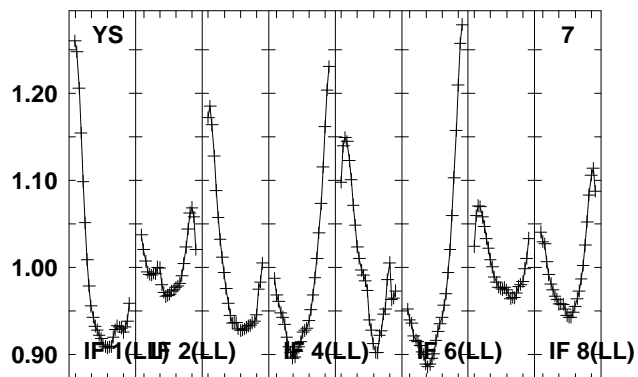
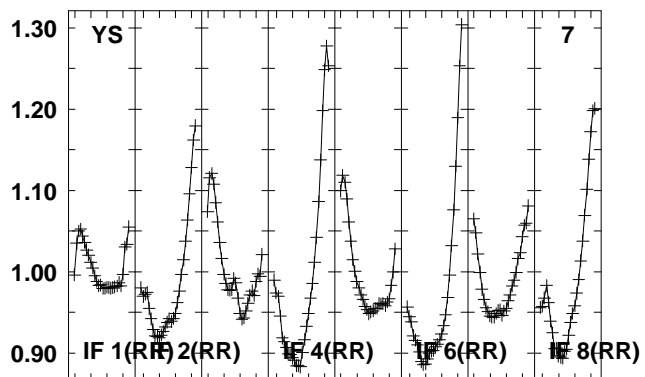
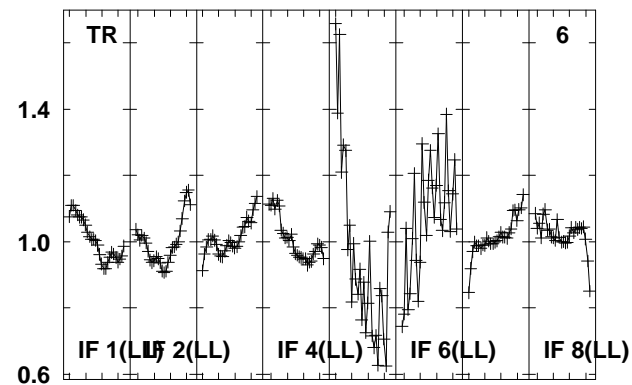
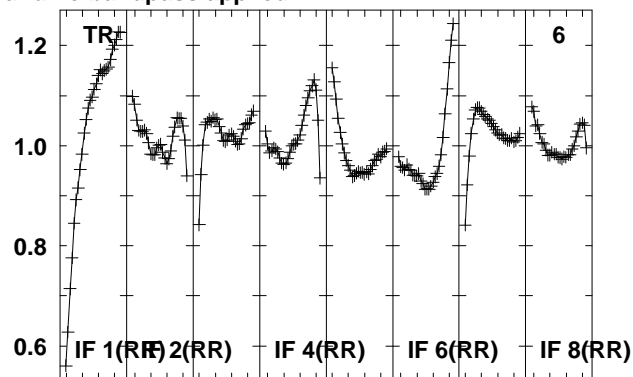
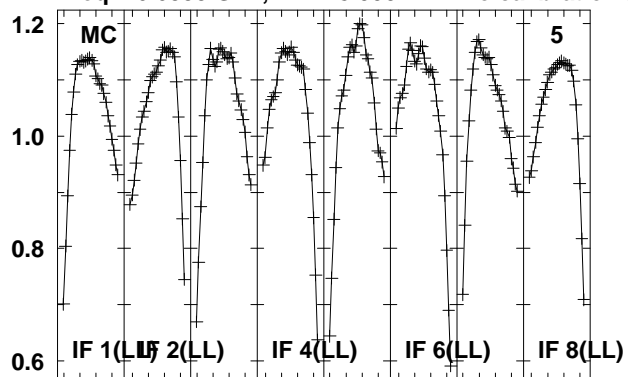

Lower frame: Real Jy

Total-power spectrum Antenna: *

Timerange: 00/13:55:29 to 00/13:56:57

Plot file version 171 created 15-MAR-2012 17:32:28

G85.40 EZ020E 2.UVDATA.1

Freq = 6.6335 GHz, Bw = 8.000 MH No calibration applied and no bandpass applied

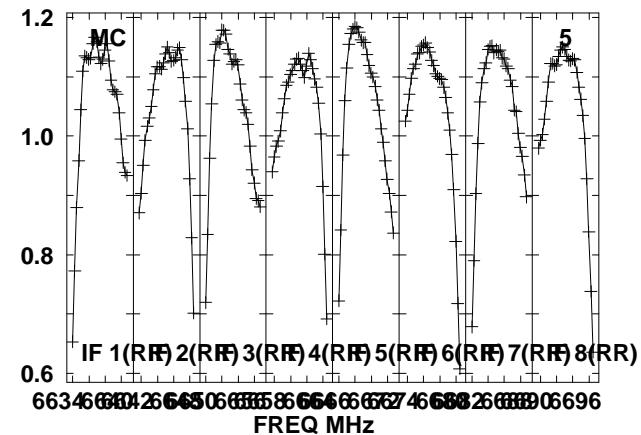
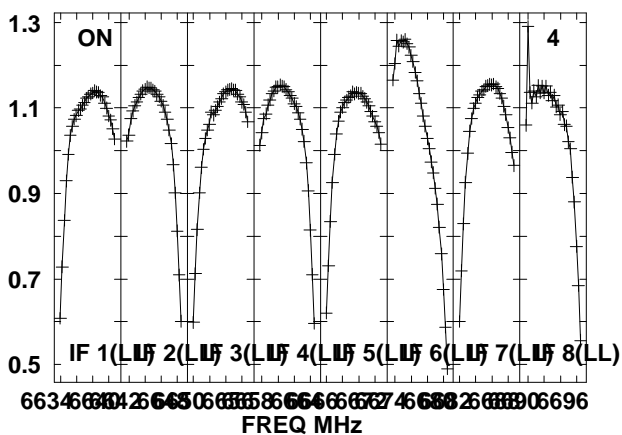
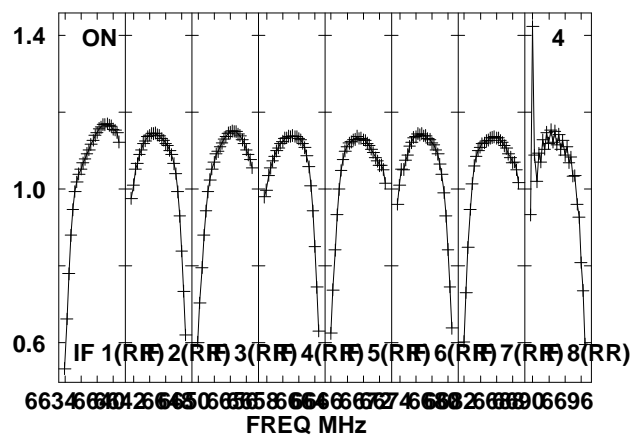
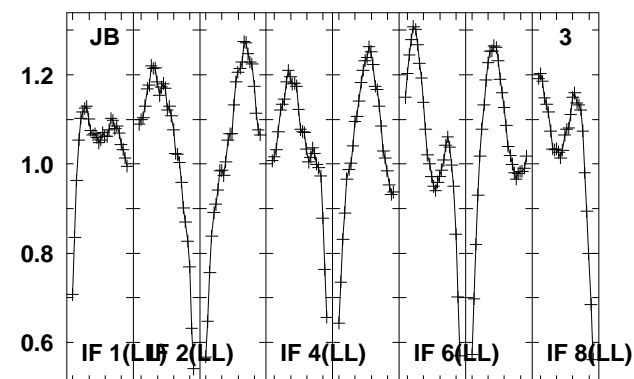
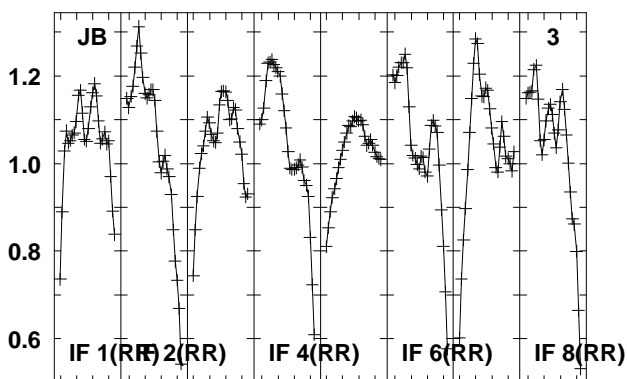
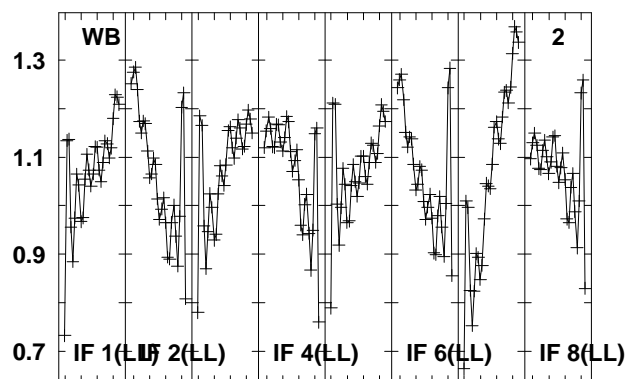
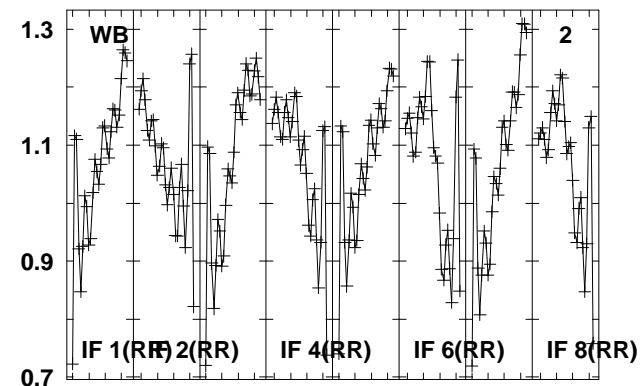
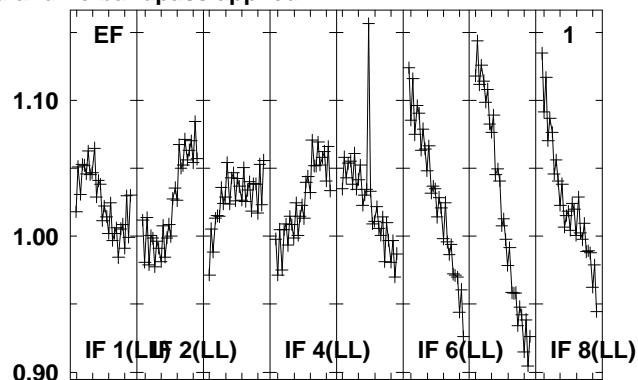
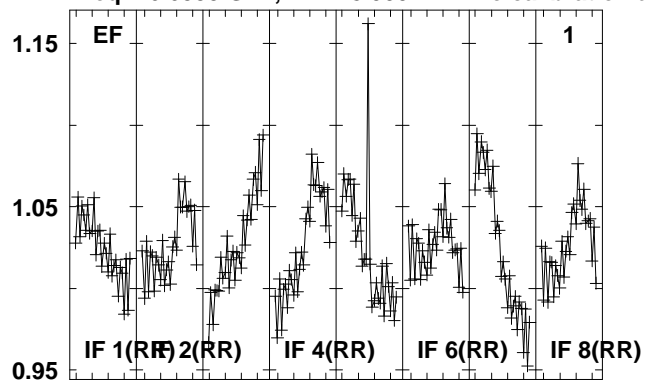

Lower frame: Real Jy

Total-power spectrum Antenna: *

Timerange: 00/13:57:40 to 00/13:58:39

Plot file version 174 created 15-MAR-2012 17:32:29

G85.40 EZ020E 2.UVDATA.1

Freq = 6.6335 GHz, Bw = 8.000 MH No calibration applied and no bandpass applied

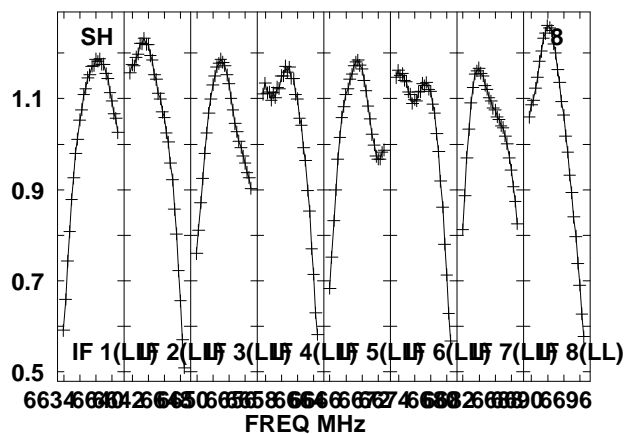
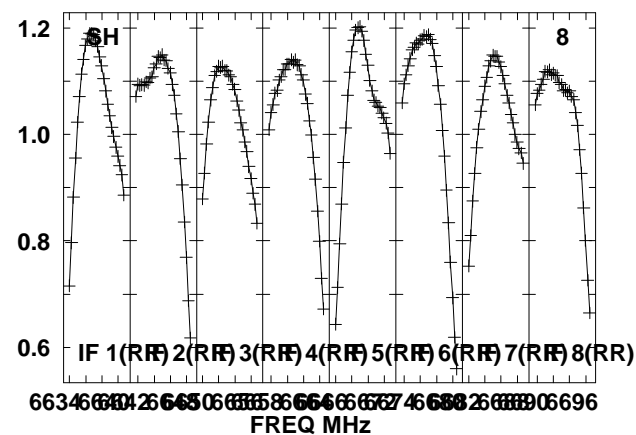
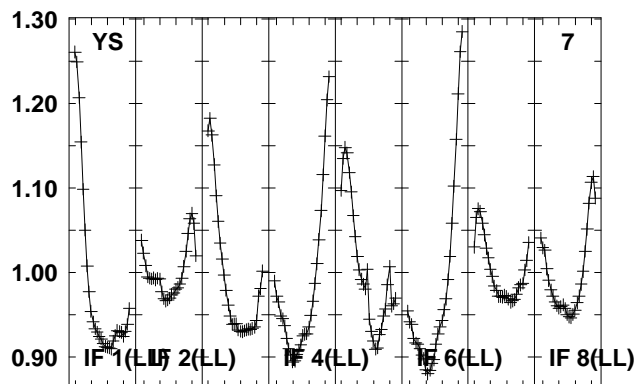
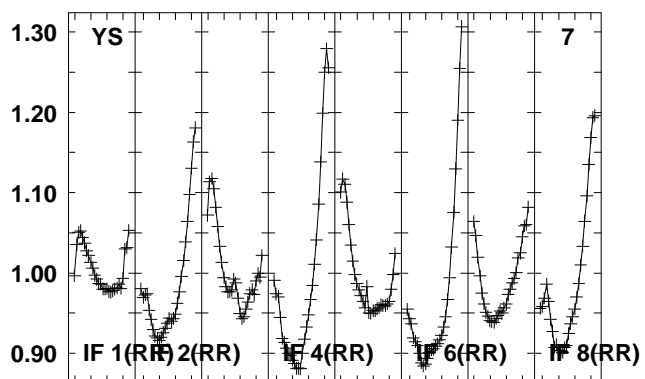
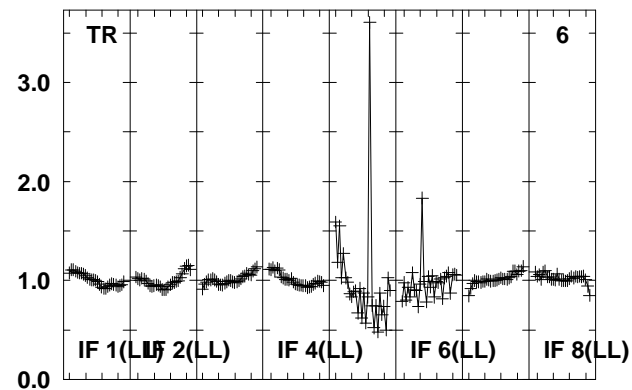
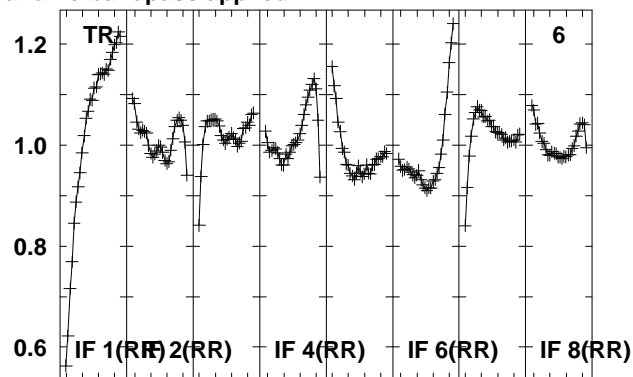
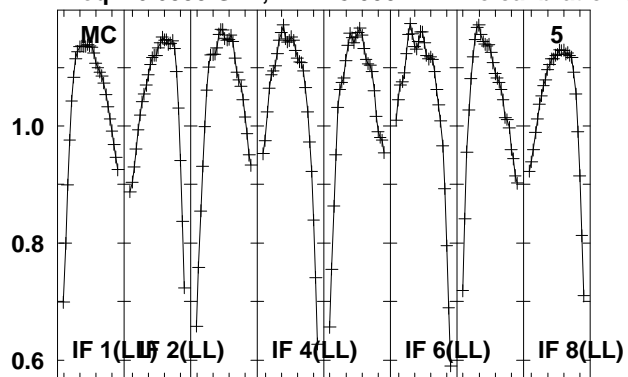

Lower frame: Real Jy

Total-power spectrum Antenna: *

Timerange: 00/14:31:41 to 00/14:32:38

Plot file version 175 created 15-MAR-2012 17:32:30

2102-G85 EZ020E 2.UVDATA.1

Freq = 6.6335 GHz, Bw = 8.000 MH No calibration applied and no bandpass applied

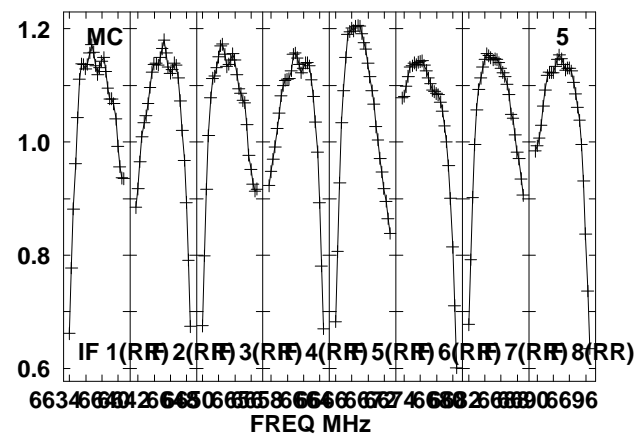
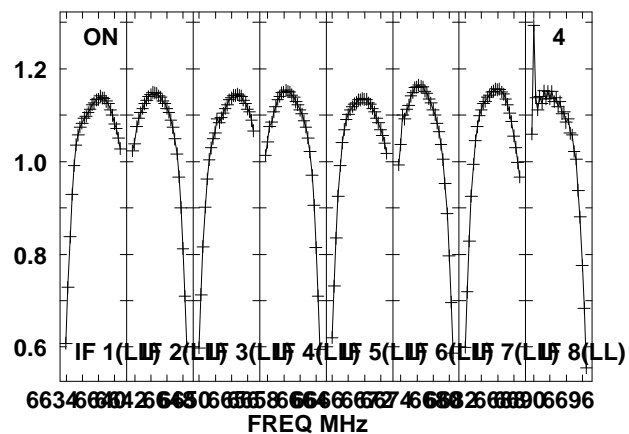
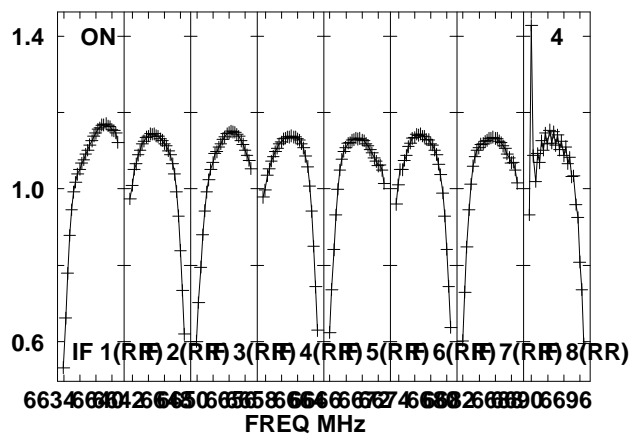
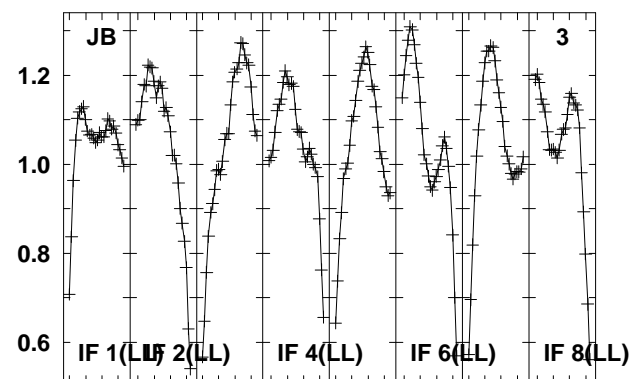
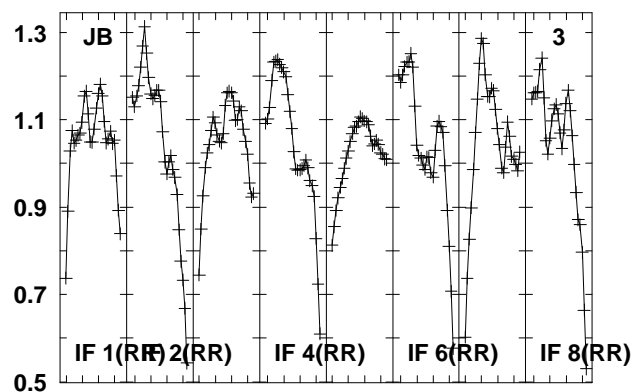
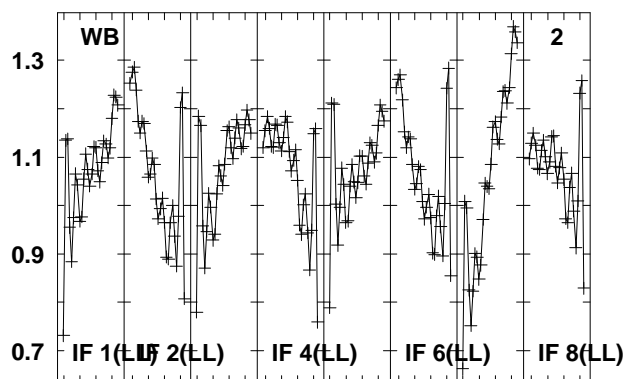
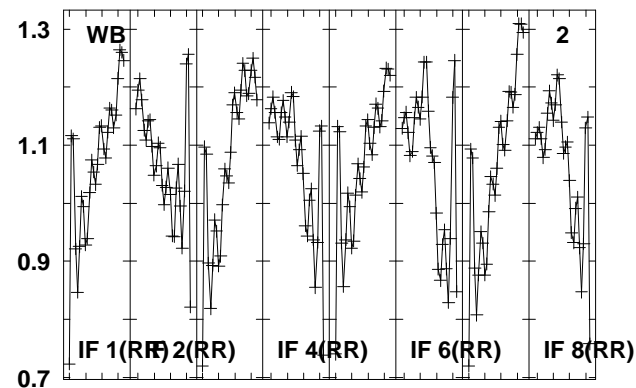
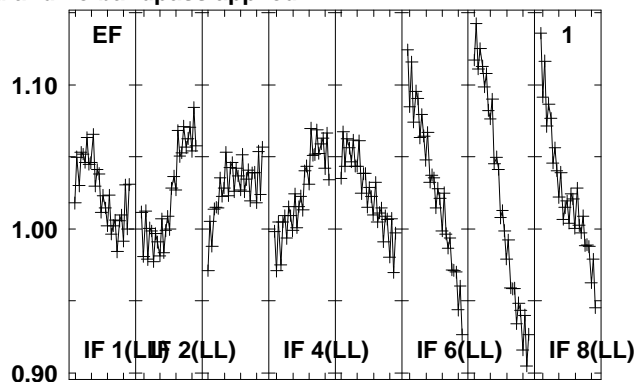
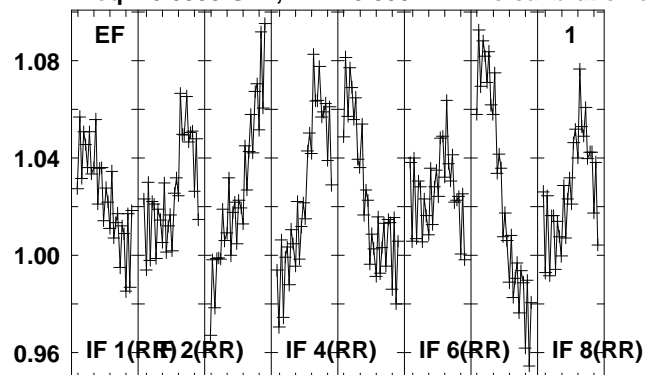

Lower frame: Real Jy

Total-power spectrum Antenna: *

Timerange: 00/14:32:41 to 00/14:34:09

Plot file version 176 created 15-MAR-2012 17:32:31

2102-G85 EZ020E 2.UVDATA.1

Freq = 6.6335 GHz, Bw = 8.000 MH No calibration applied and no bandpass applied

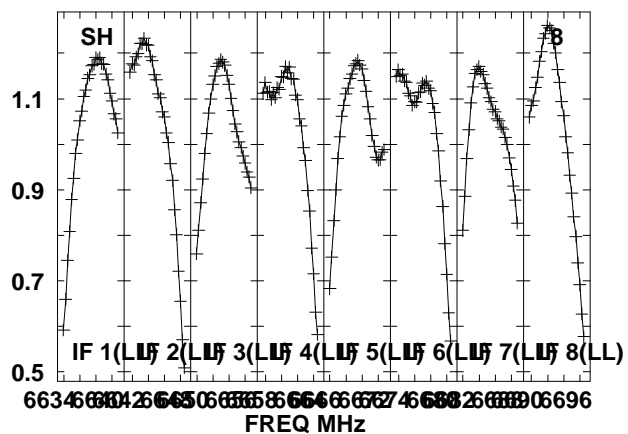
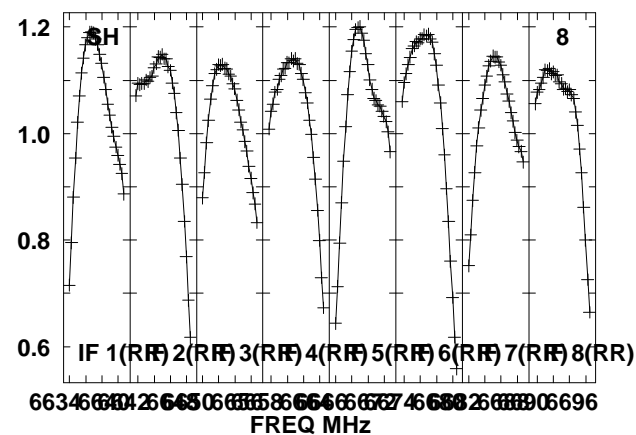
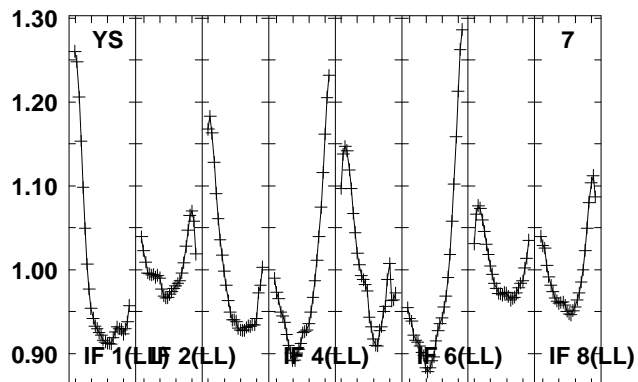
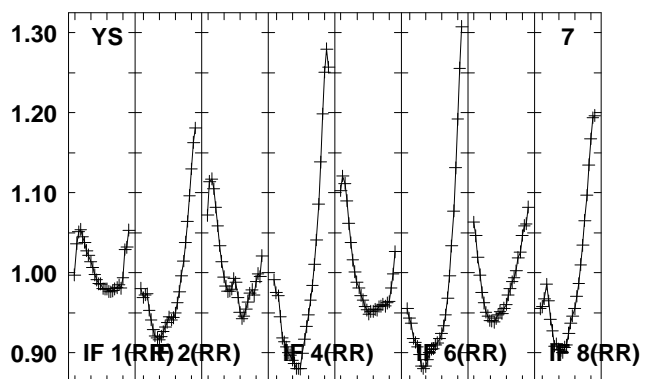
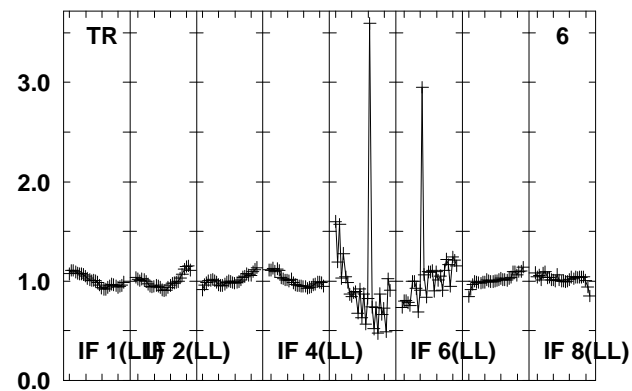
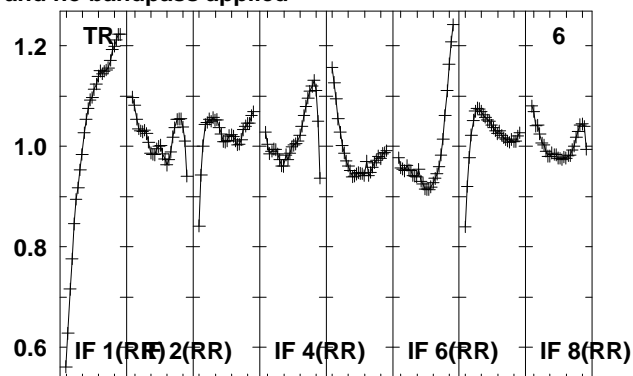
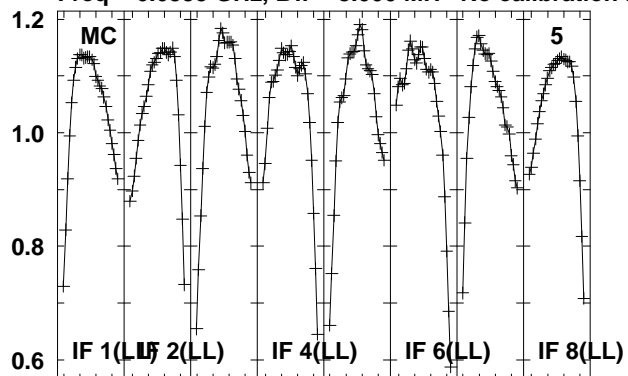

Lower frame: Real Jy

Total-power spectrum Antenna: *

Timerange: 00/14:32:41 to 00/14:34:09

Plot file version 177 created 15-MAR-2012 17:32:32

G85.40 EZ020E 2.UVDATA.1

Freq = 6.6335 GHz, Bw = 8.000 MH No calibration applied and no bandpass applied

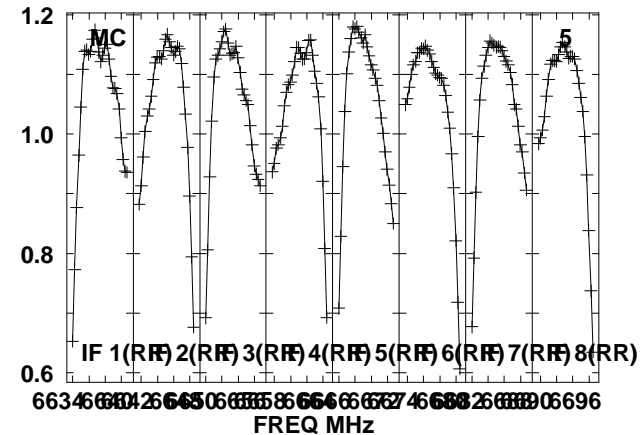
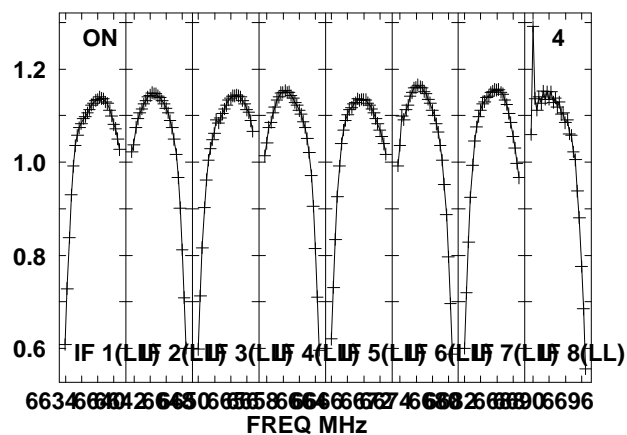
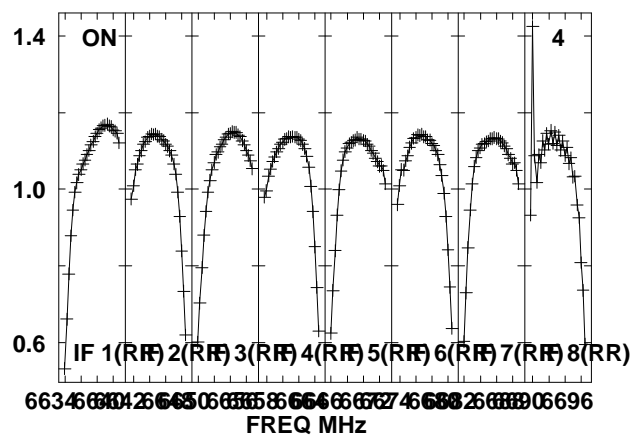
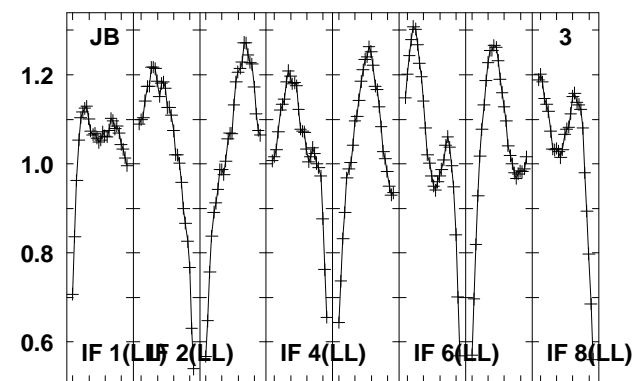
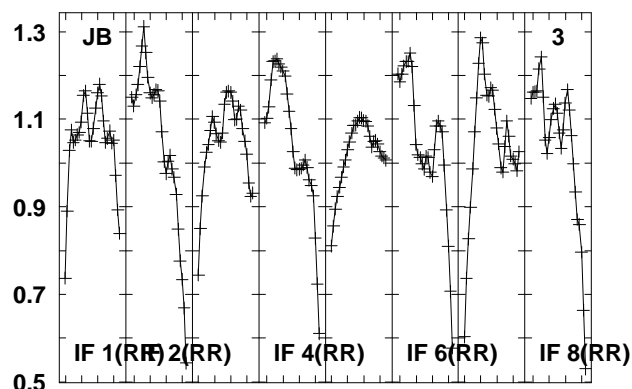
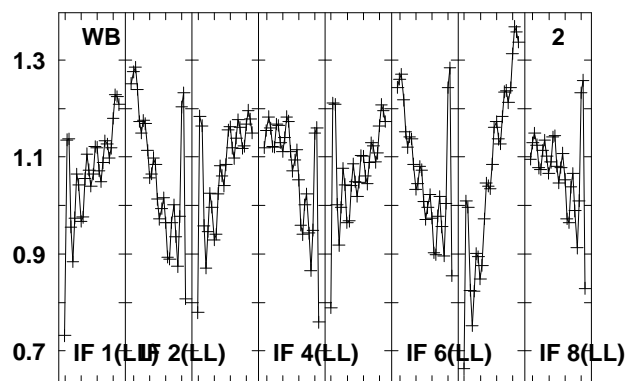
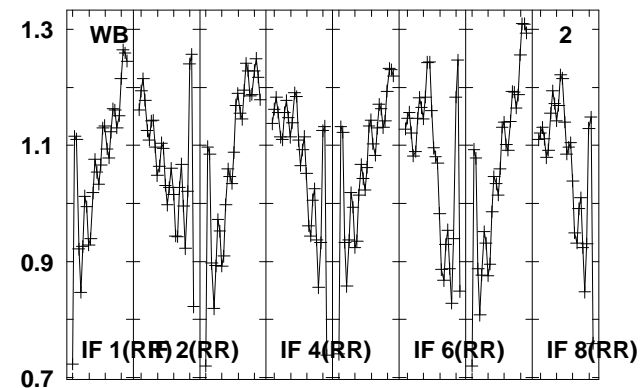
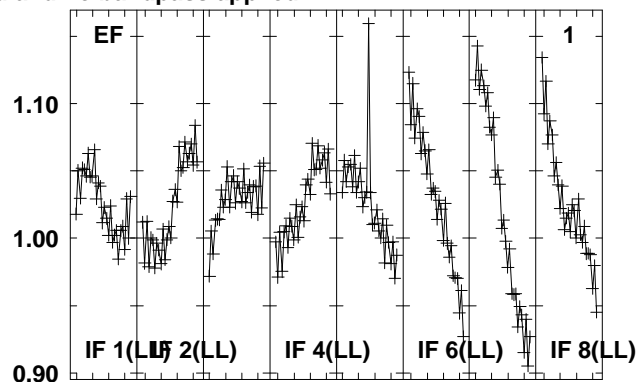
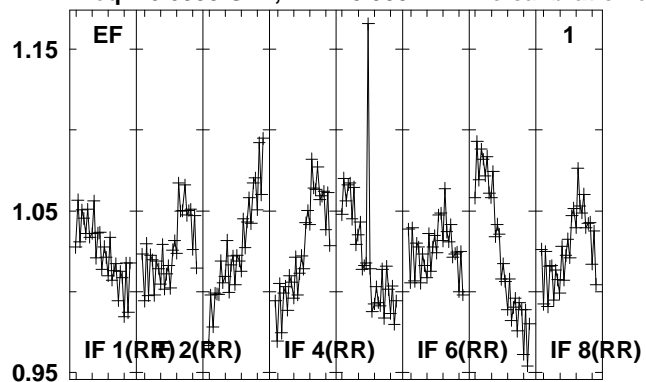

Lower frame: Real Jy
Total-power spectrum Antenna: *
Timerange: 00/14:34:11 to 00/14:35:39

Plot file version 178 created 15-MAR-2012 17:32:32

G85.40 EZ020E 2.UVDATA.1

Freq = 6.6335 GHz, Bw = 8.000 MH No calibration applied and no bandpass applied

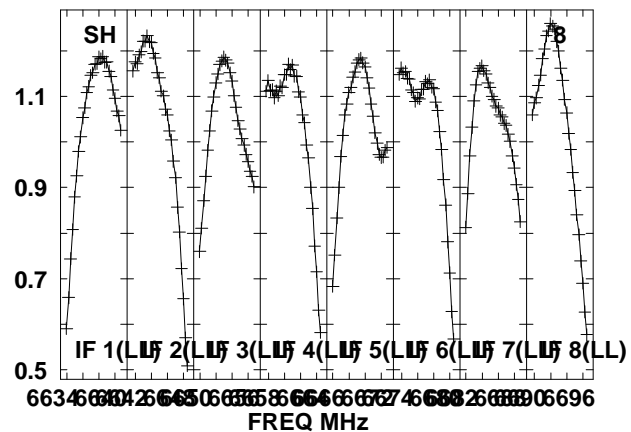
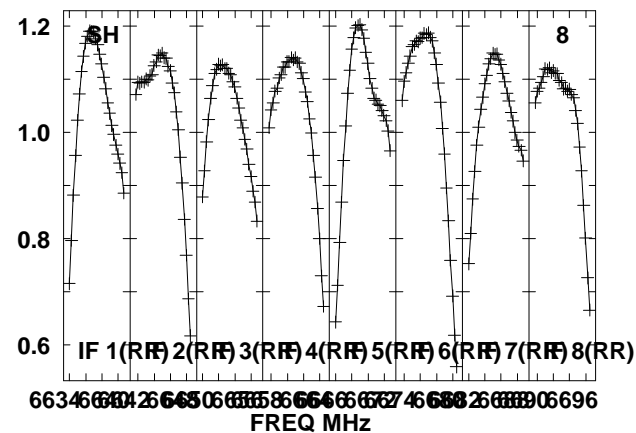
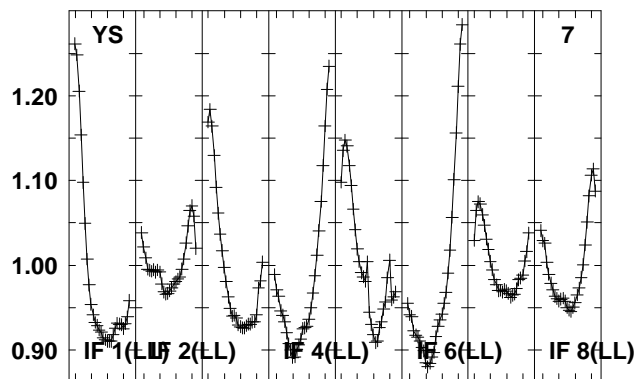
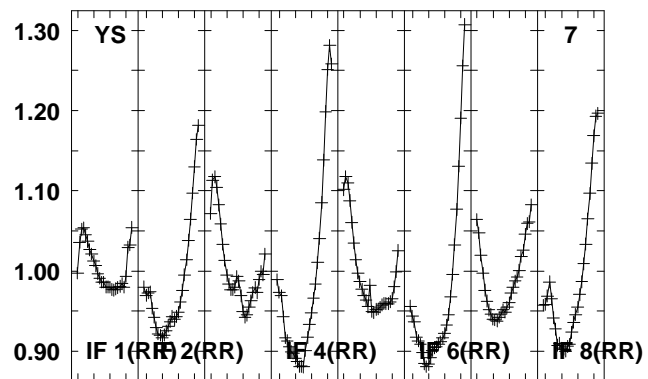
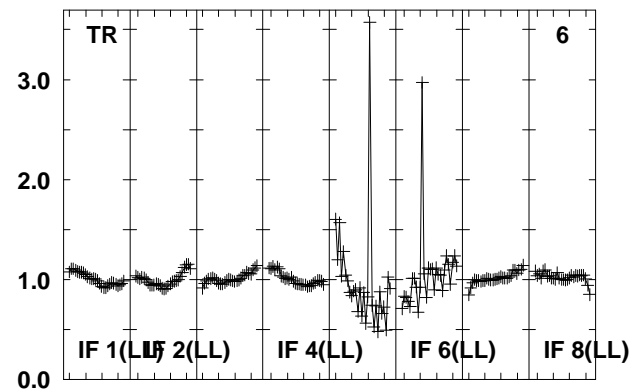
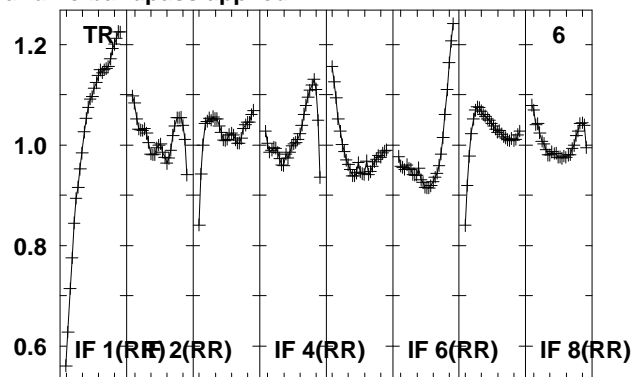
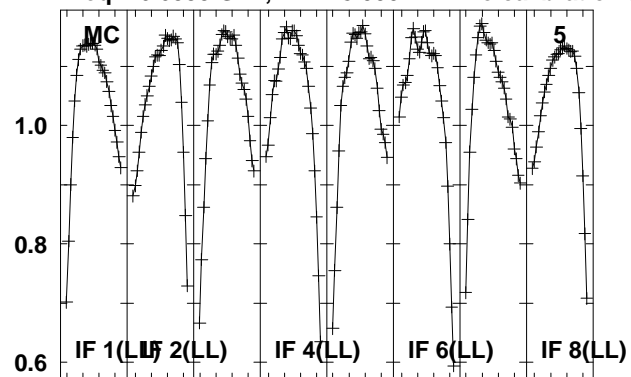

Lower frame: Real Jy

Total-power spectrum Antenna: *

Timerange: 00/14:34:11 to 00/14:35:39

Plot file version 179 created 15-MAR-2012 17:32:33

2114-G85 EZ020E 2.UVDATA.1

Freq = 6.6335 GHz, Bw = 8.000 MH No calibration applied and no bandpass applied

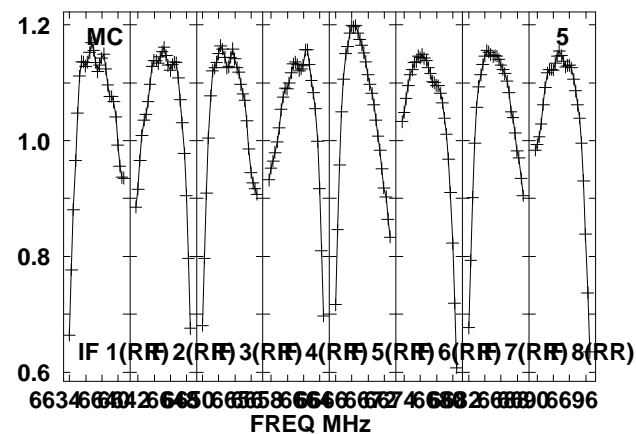
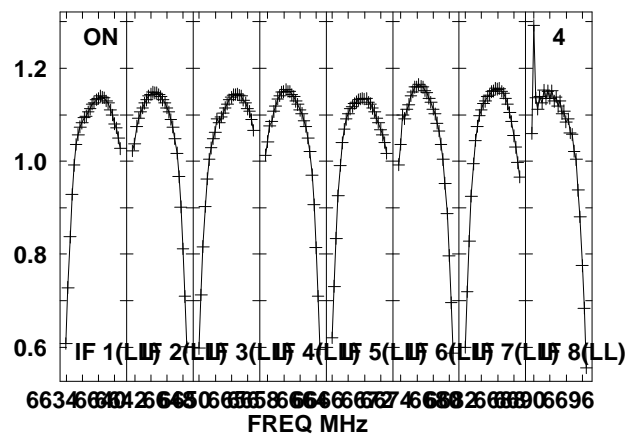
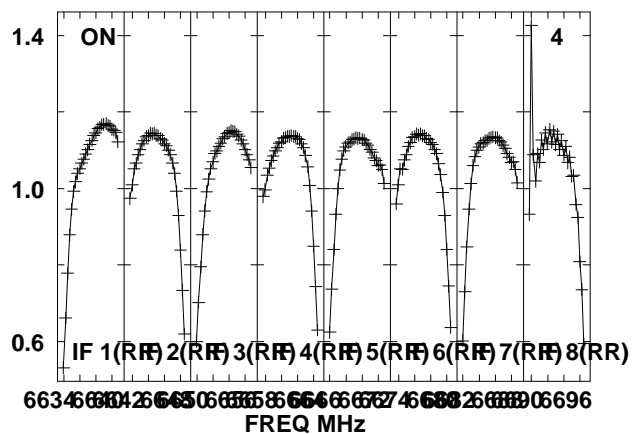
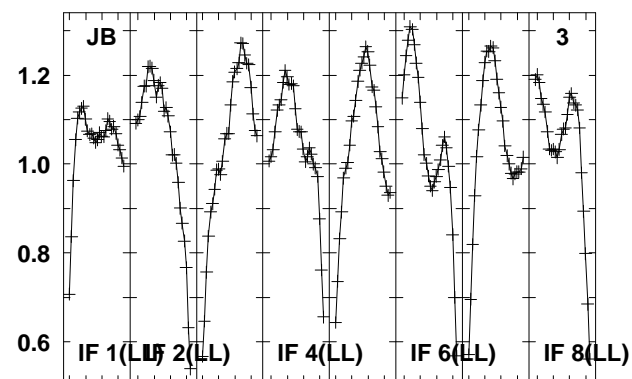
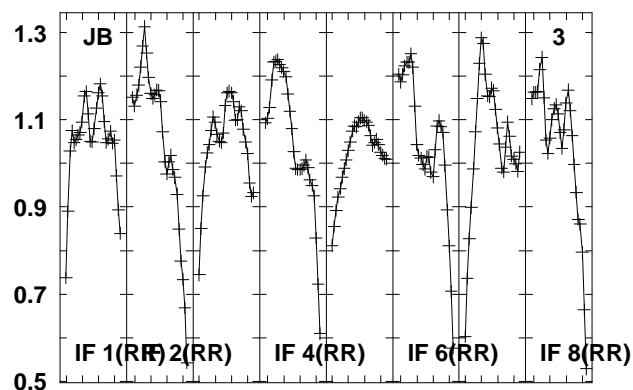
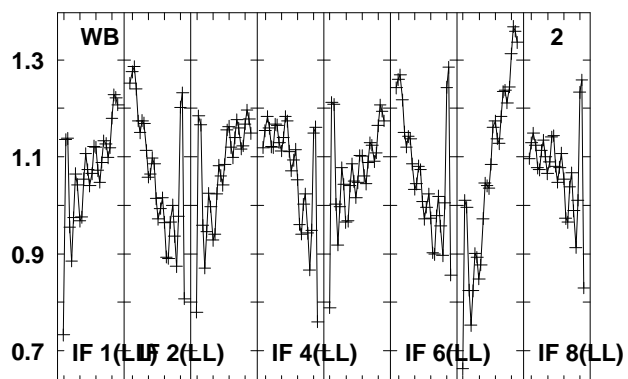
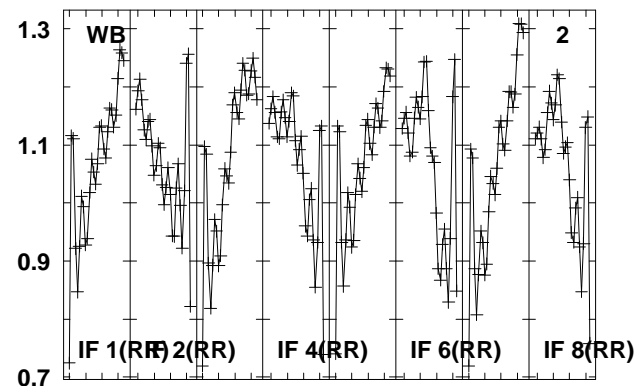
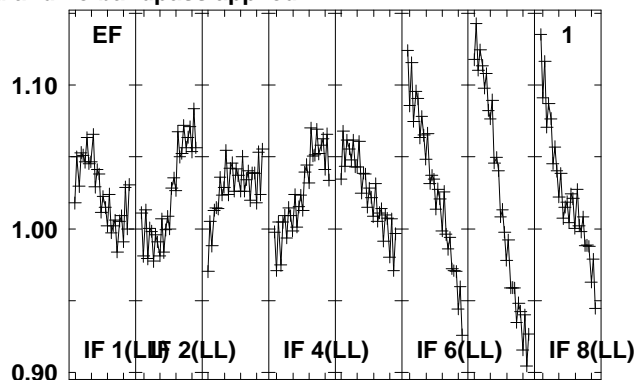
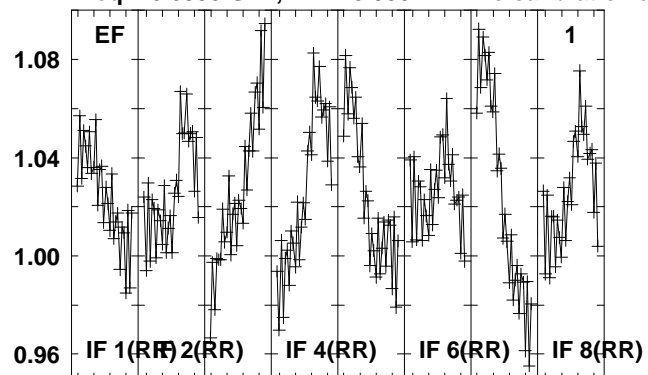

Lower frame: Real Jy

Total-power spectrum Antenna: *

Timerange: 00/14:35:40 to 00/14:37:08

Plot file version 180 created 15-MAR-2012 17:32:33

2114-G85 EZ020E 2.UVDATA.1

Freq = 6.6335 GHz, Bw = 8.000 MH No calibration applied and no bandpass applied

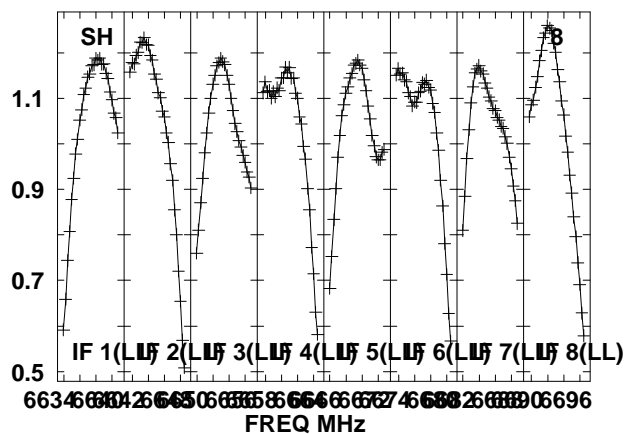
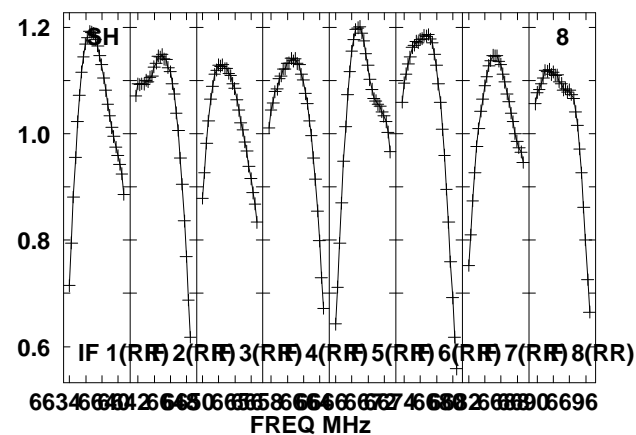
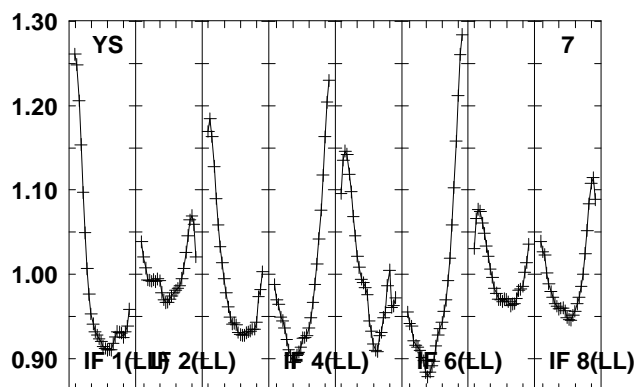
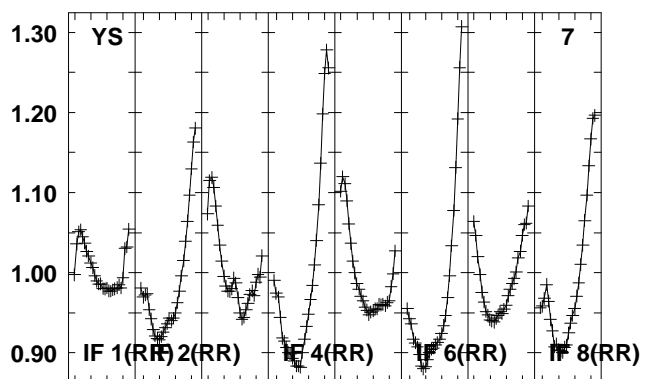
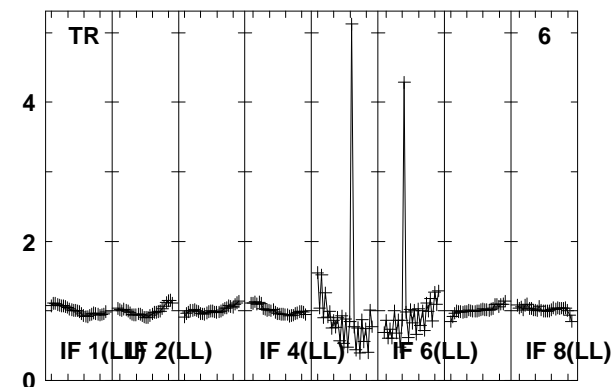
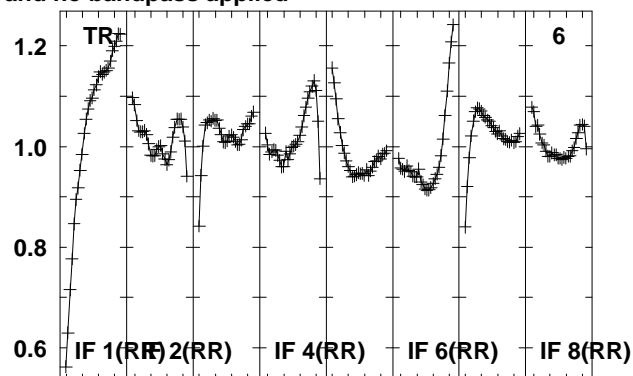
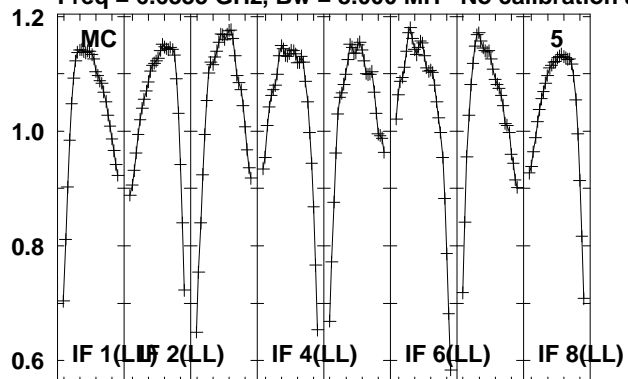

Lower frame: Real Jy
Total-power spectrum Antenna: *
Timerange: 00/14:35:40 to 00/14:37:08

Plot file version 181 created 15-MAR-2012 17:32:35

G85.40 EZ020E 2.UVDATA.1

Freq = 6.6335 GHz, Bw = 8.000 MH No calibration applied and no bandpass applied

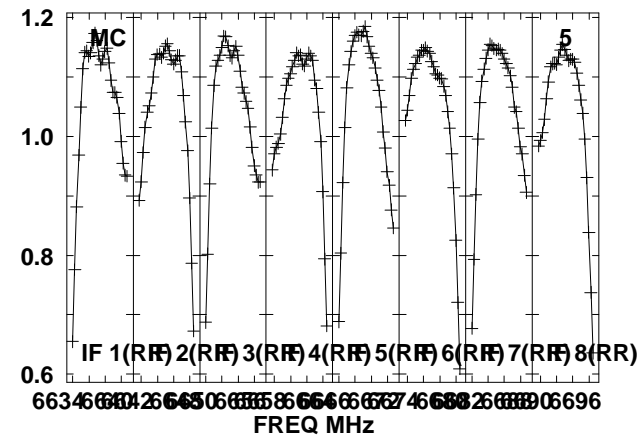
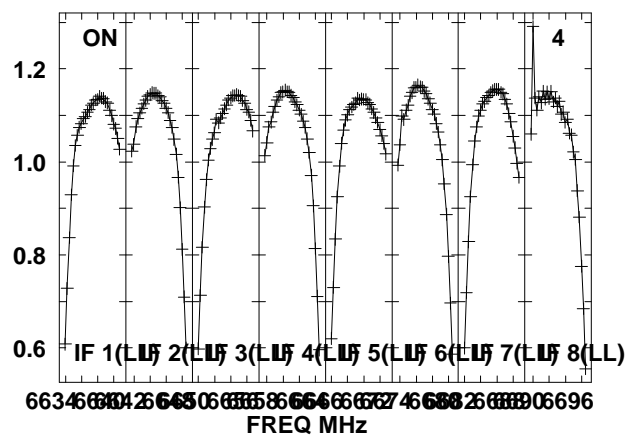
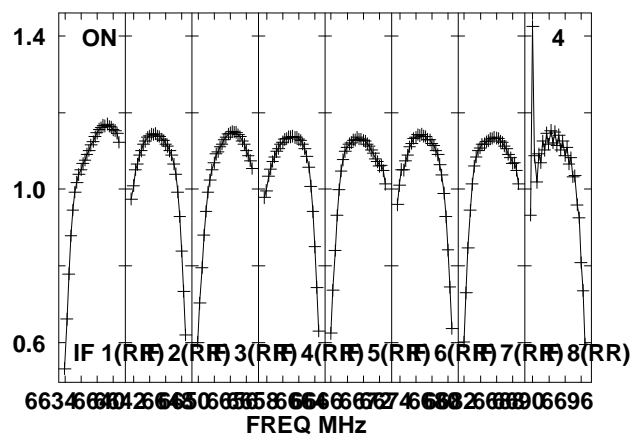
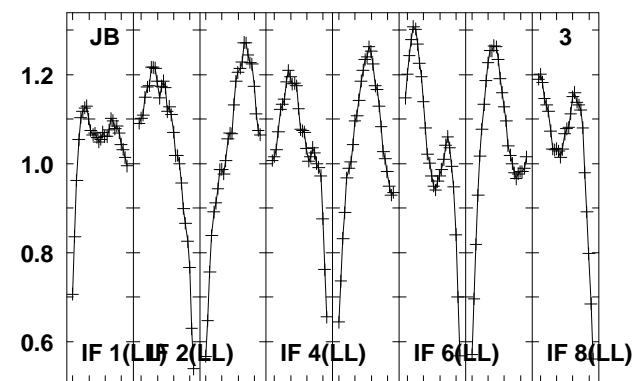
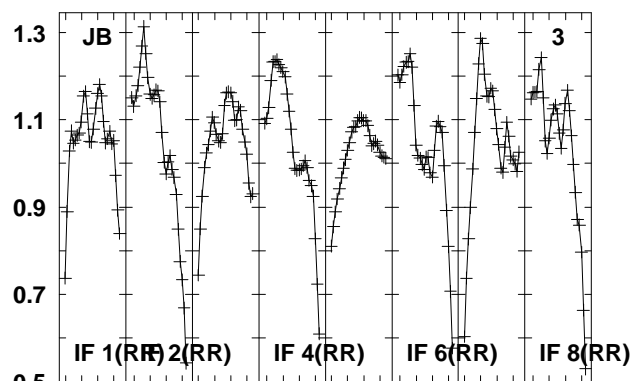
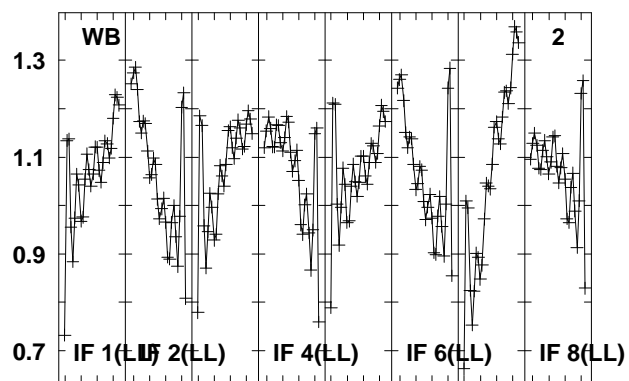
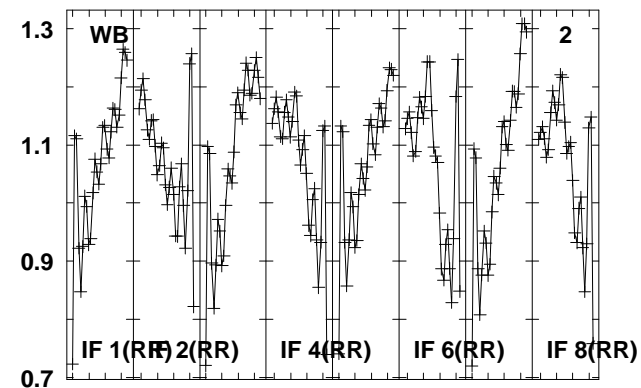
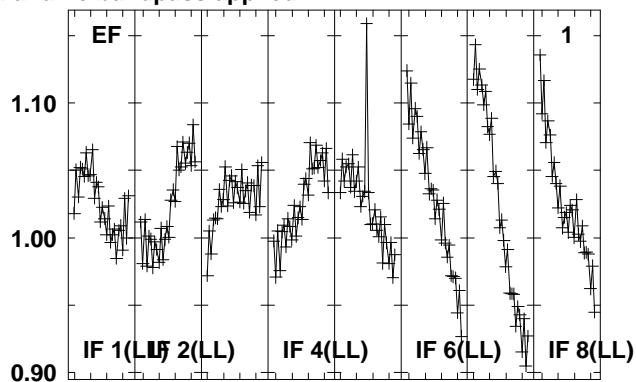
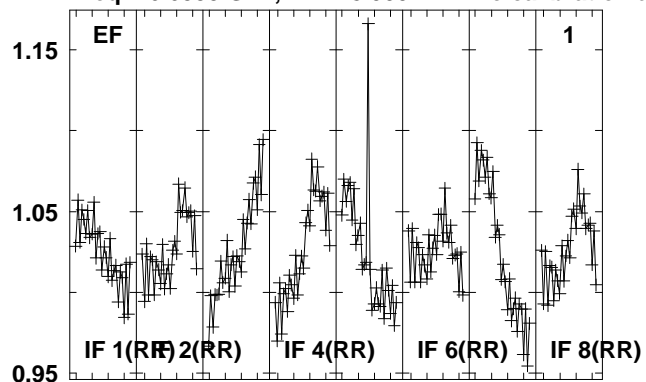

Lower frame: Real Jy
Total-power spectrum Antenna: *
Timerange: 00/14:37:10 to 00/14:38:38

Plot file version 182 created 15-MAR-2012 17:32:35

G85.40 EZ020E 2.UVDATA.1

Freq = 6.6335 GHz, Bw = 8.000 MH No calibration applied and no bandpass applied

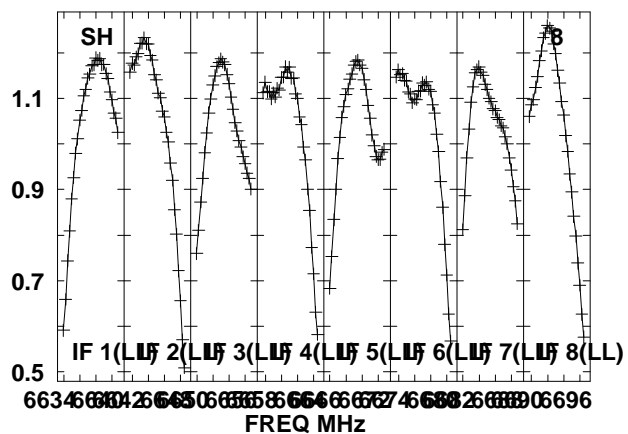
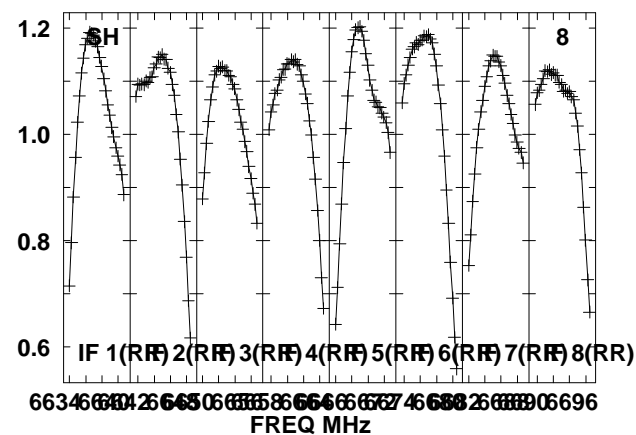
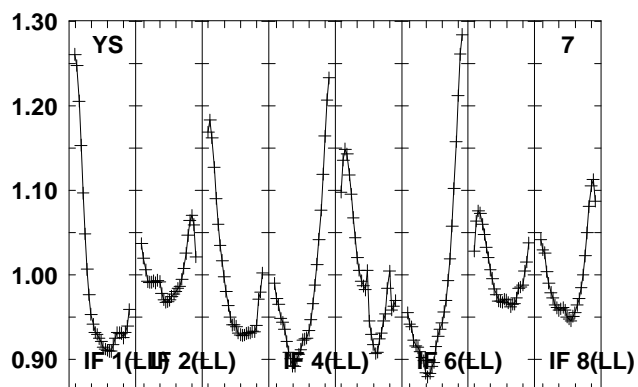
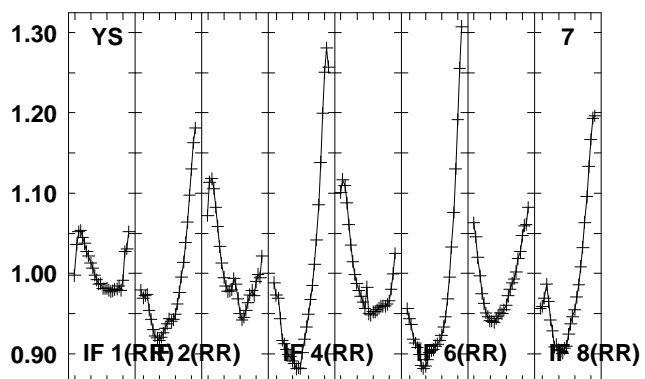
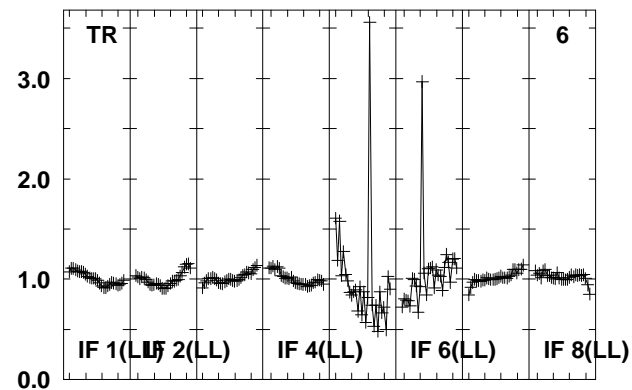
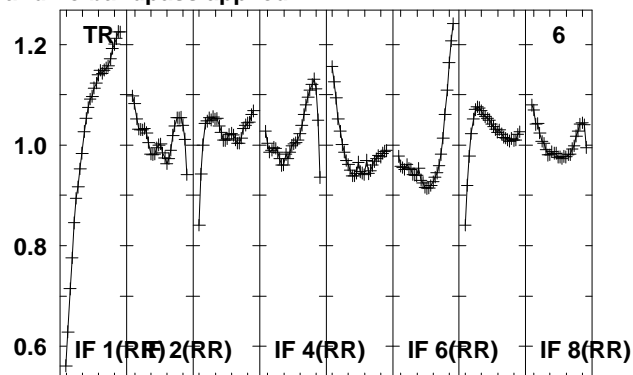
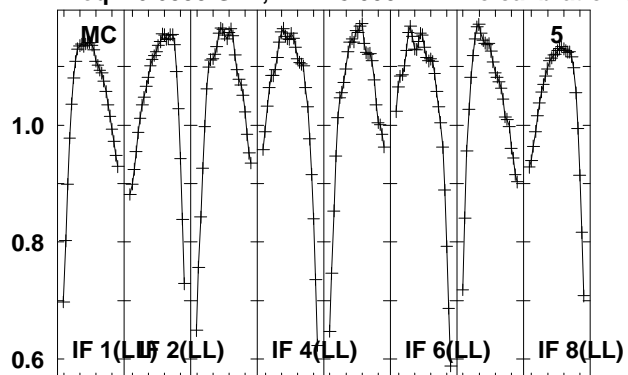

Lower frame: Real Jy

Total-power spectrum Antenna: *

Timerange: 00/14:37:10 to 00/14:38:38

Plot file version 183 created 15-MAR-2012 17:32:36
 2102-G85 EZ020E 2.UVDATA.1
 Freq = 6.6335 GHz, Bw = 8.000 MH No calibration applied and no bandpass applied

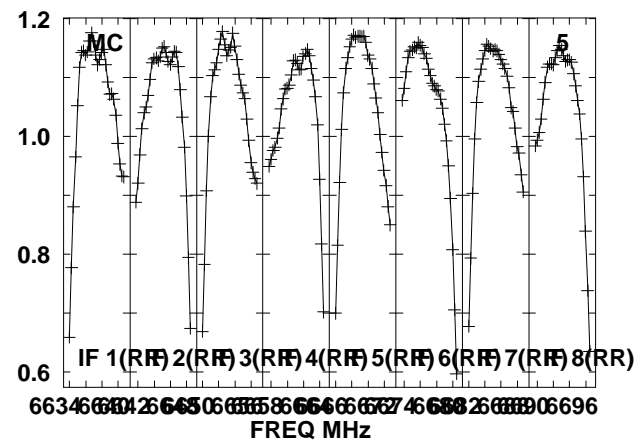
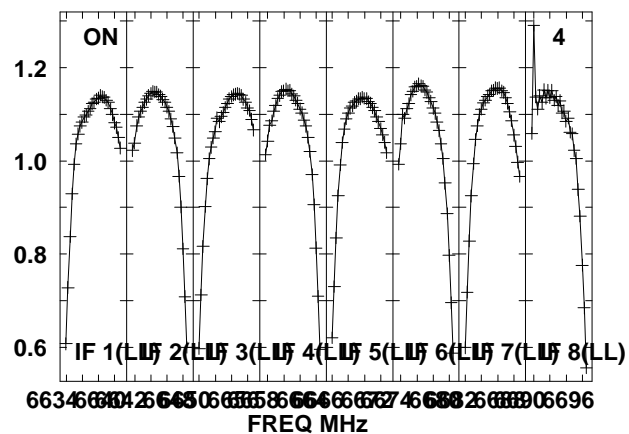
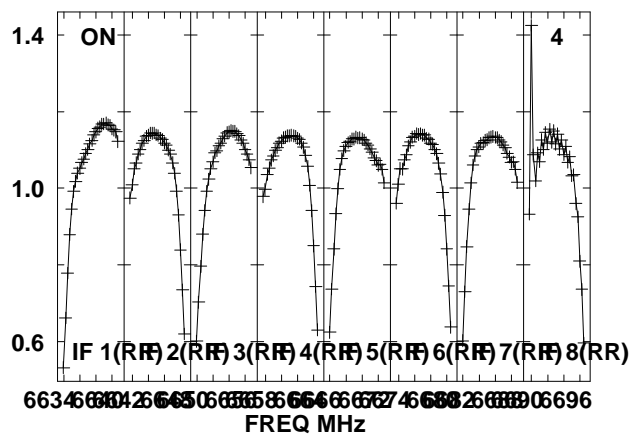
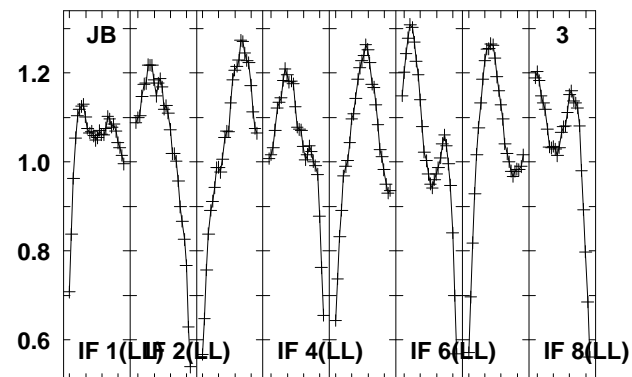
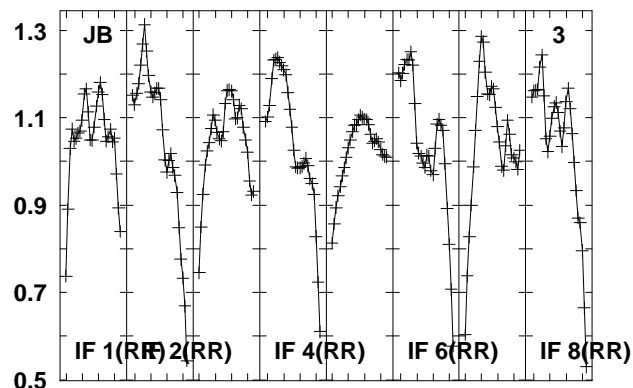
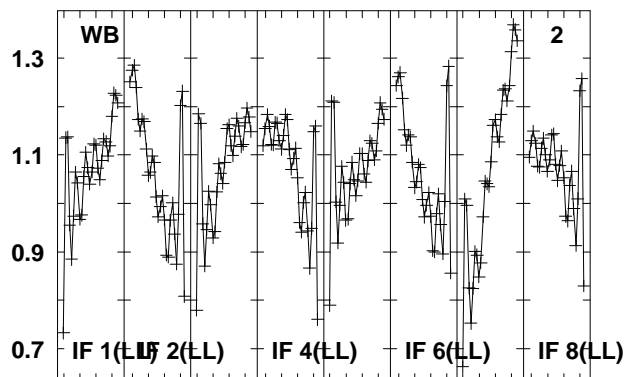
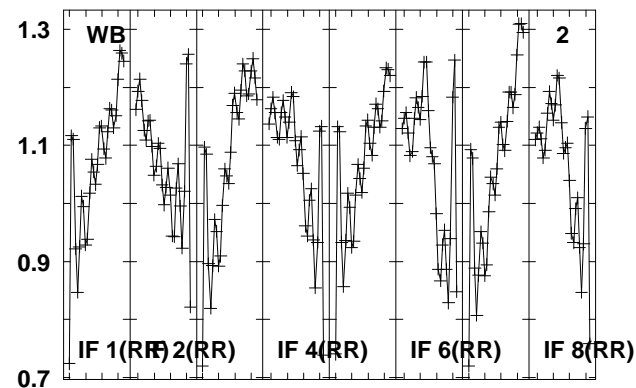
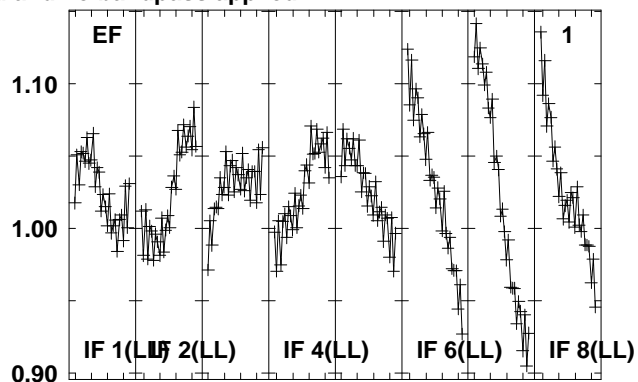
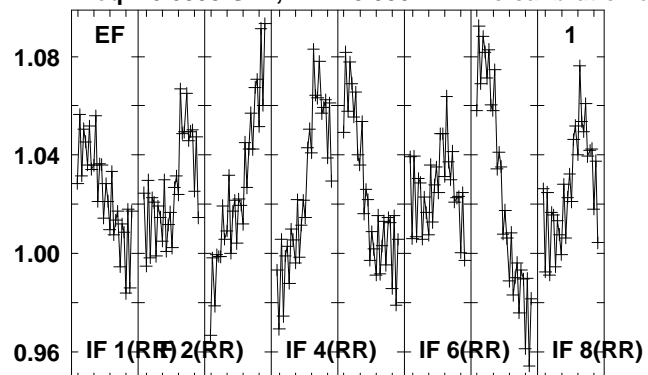

Lower frame: Real Jy
 Total-power spectrum Antenna: *
 Timerange: 00/14:38:41 to 00/14:40:09

Plot file version 184 created 15-MAR-2012 17:32:36

2102-G85 EZ020E 2.UVDATA.1

Freq = 6.6335 GHz, Bw = 8.000 MH No calibration applied and no bandpass applied

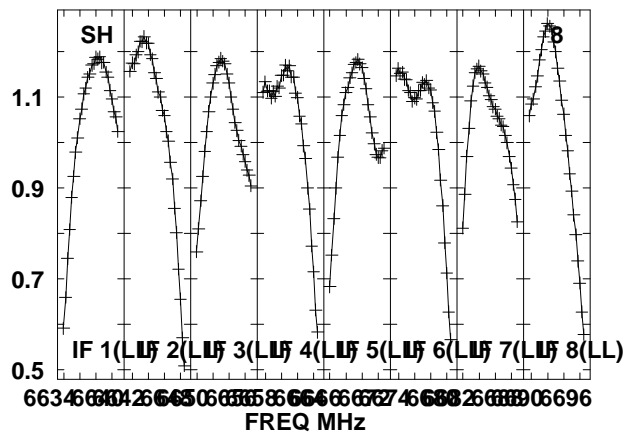
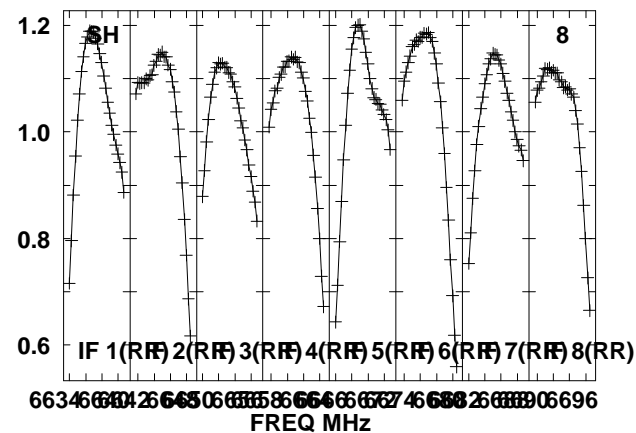
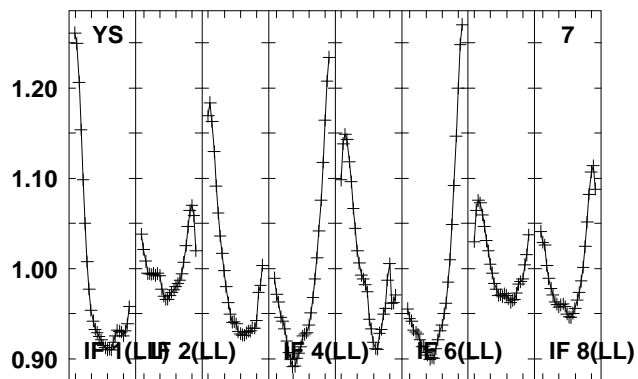
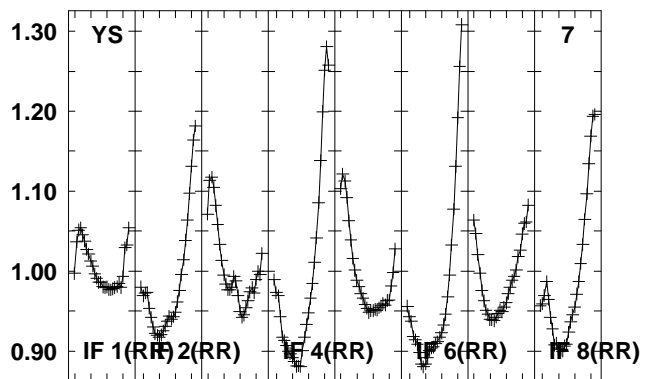
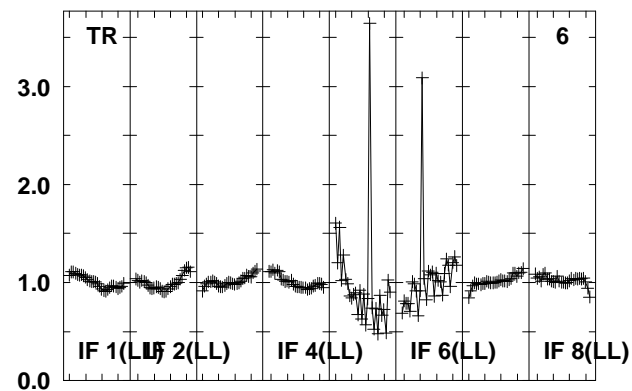
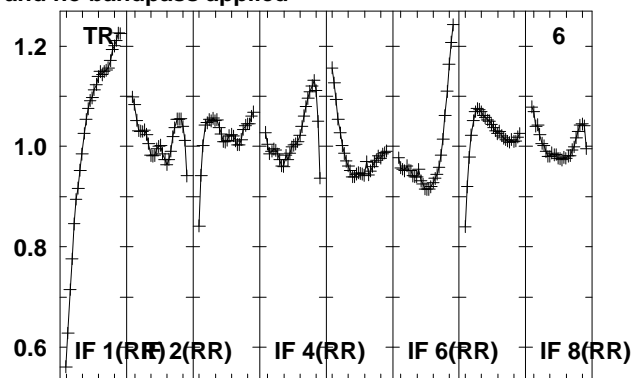
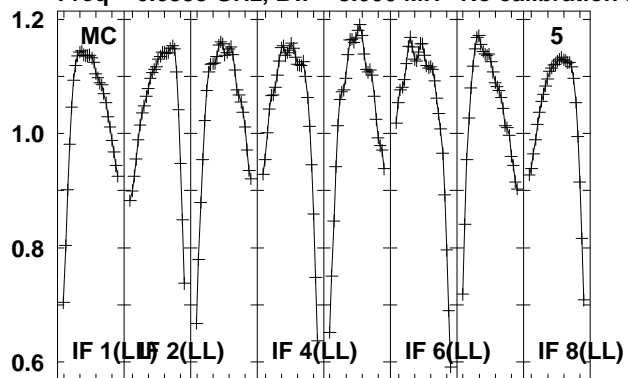

Lower frame: Real Jy

Total-power spectrum Antenna: *

Timerange: 00/14:38:41 to 00/14:40:09

Plot file version 185 created 15-MAR-2012 17:32:37

G85.40 EZ020E 2.UVDATA.1

Freq = 6.6335 GHz, Bw = 8.000 MH No calibration applied and no bandpass applied

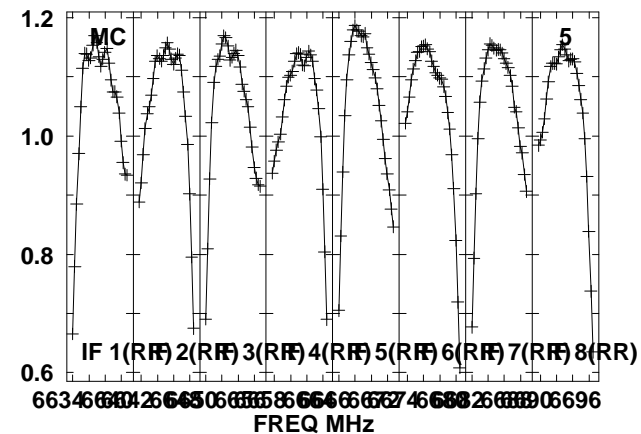
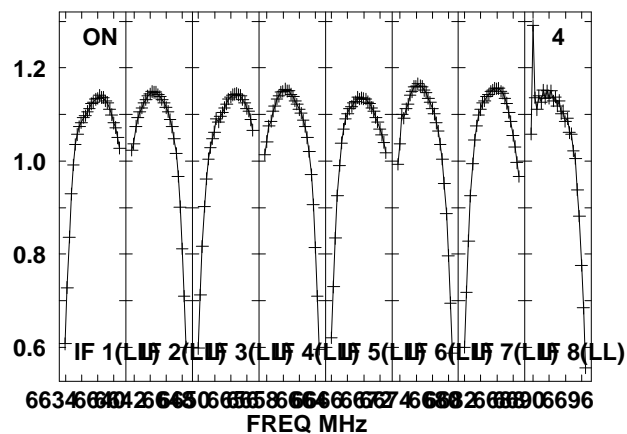
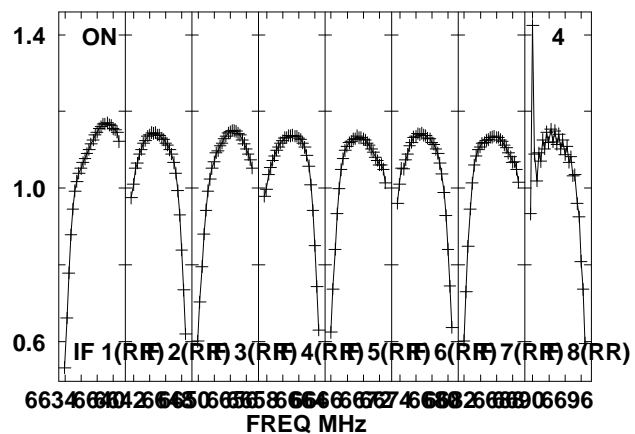
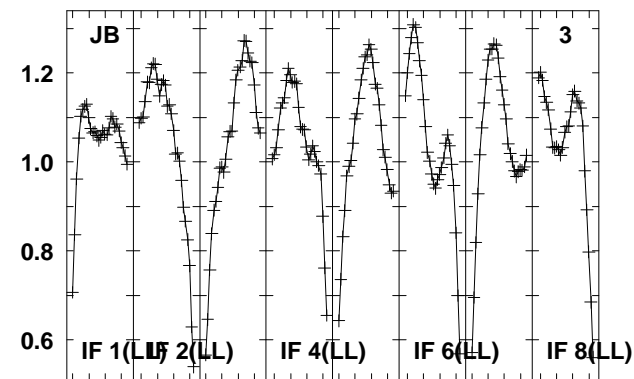
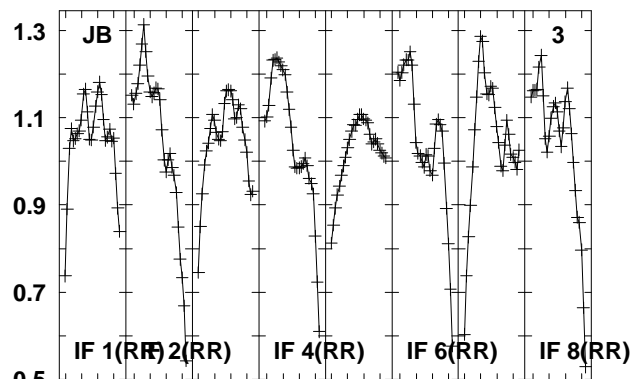
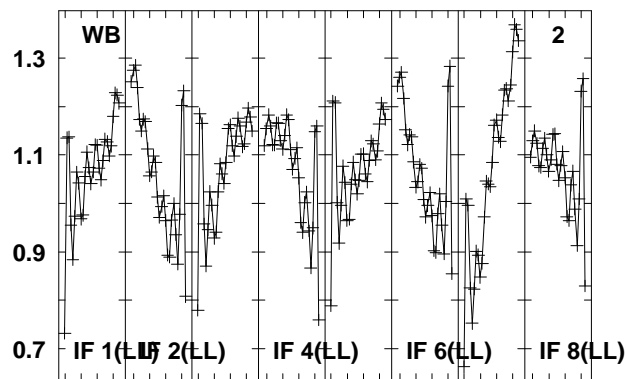
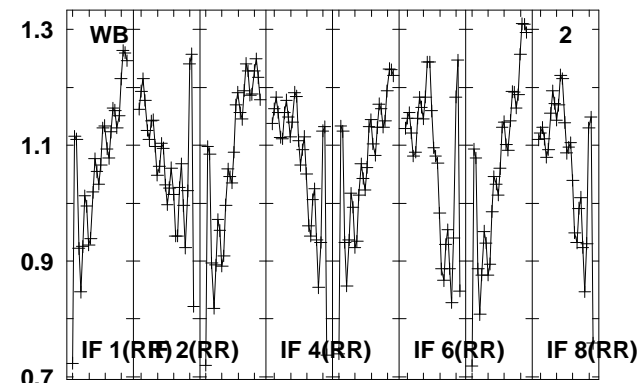
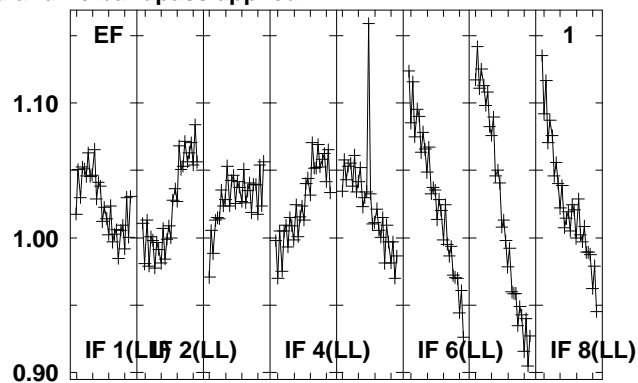
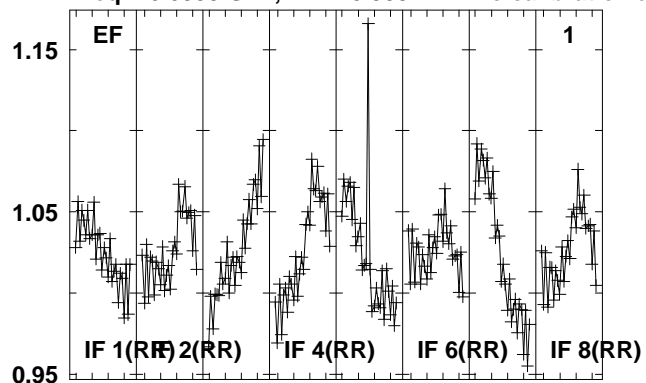

Lower frame: Real Jy
Total-power spectrum Antenna: *
Timerange: 00/14:40:10 to 00/14:41:39

Plot file version 186 created 15-MAR-2012 17:32:38

G85.40 EZ020E 2.UVDATA.1

Freq = 6.6335 GHz, Bw = 8.000 MH No calibration applied and no bandpass applied

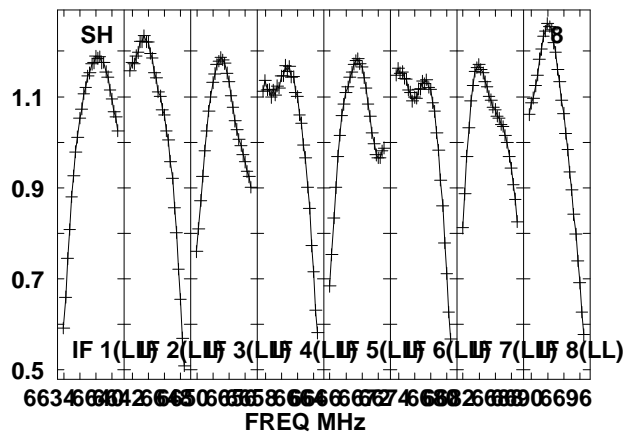
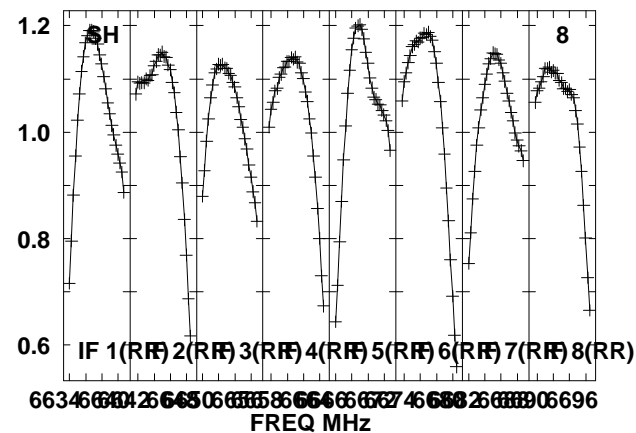
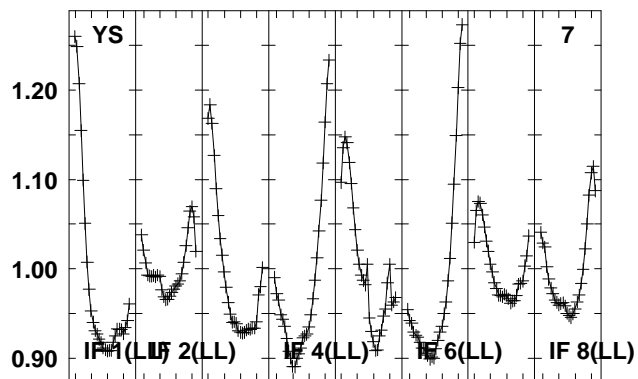
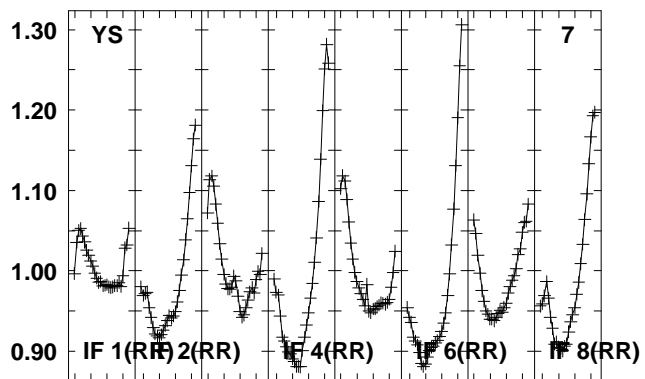
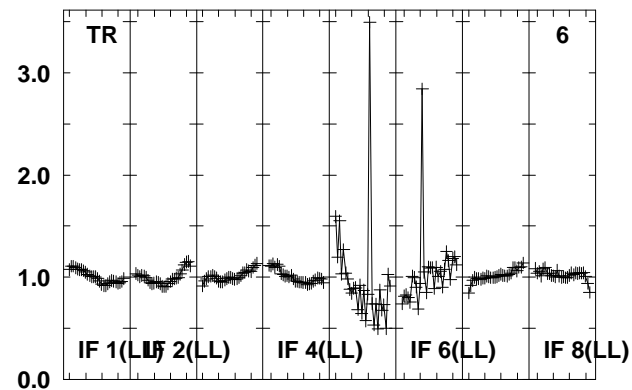
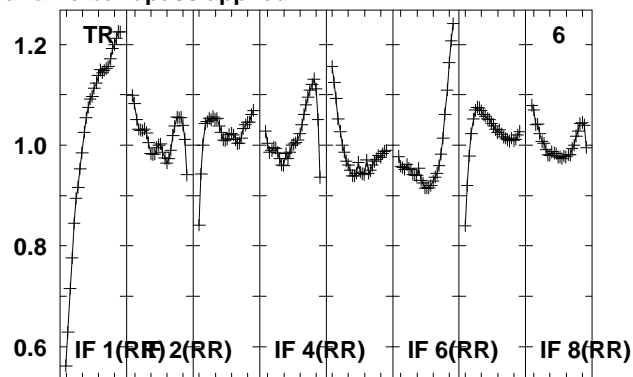
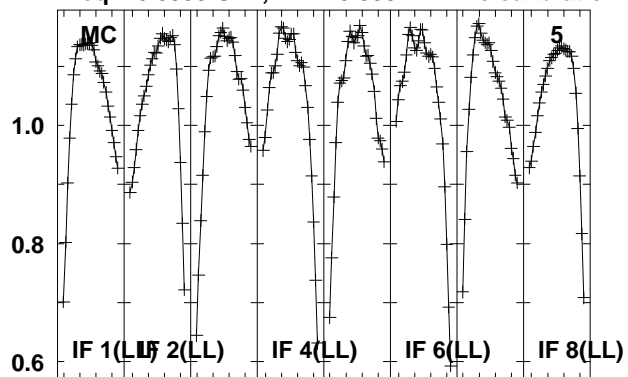

Lower frame: Real Jy

Total-power spectrum Antenna: *

Timerange: 00/14:40:10 to 00/14:41:39

Plot file version 187 created 15-MAR-2012 17:32:38
 2114-G85 EZ020E 2.UVDATA.1
 Freq = 6.6335 GHz, Bw = 8.000 MH No calibration applied and no bandpass applied

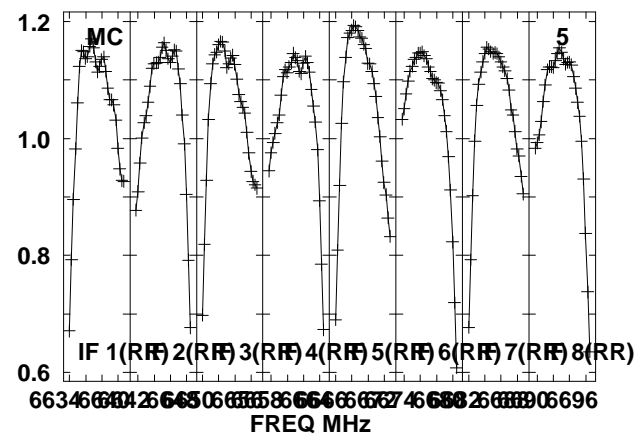
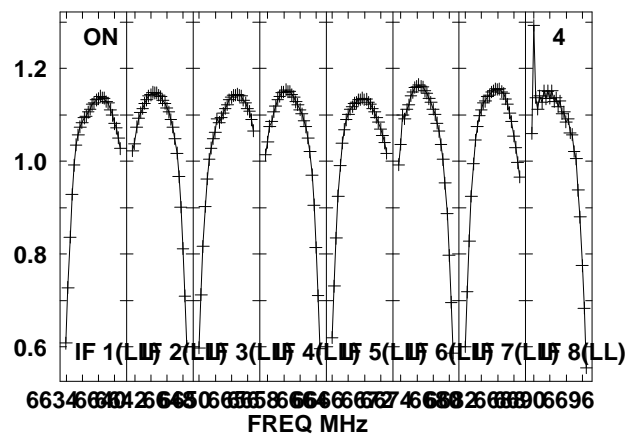
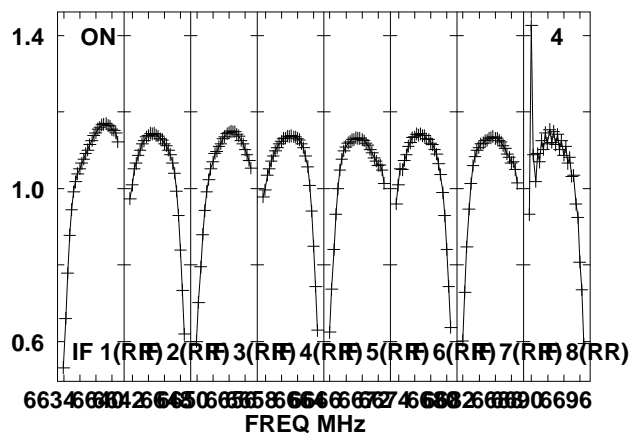
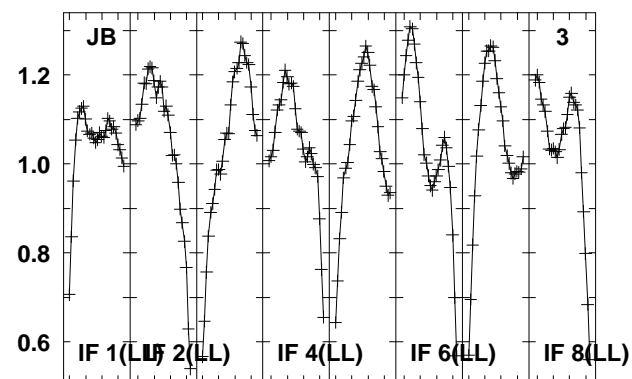
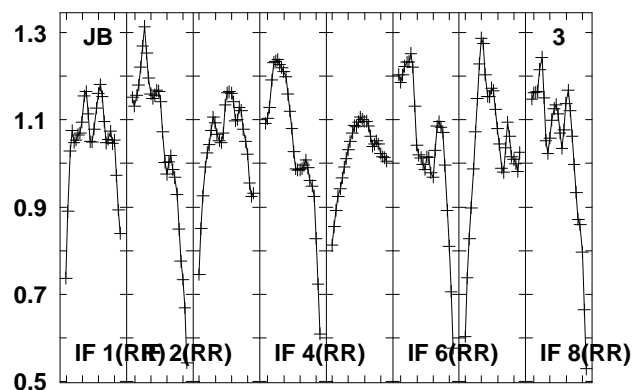
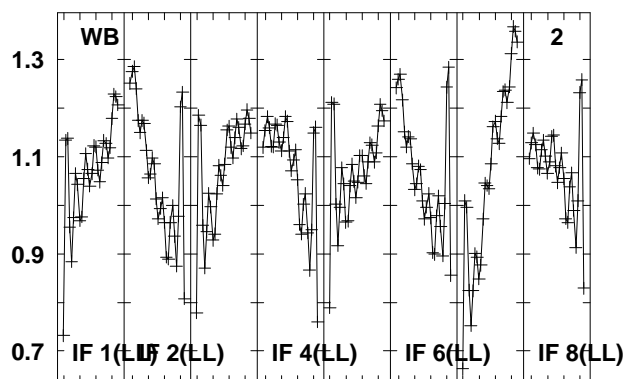
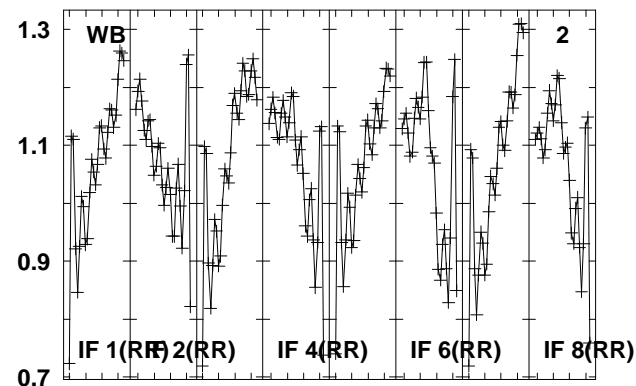
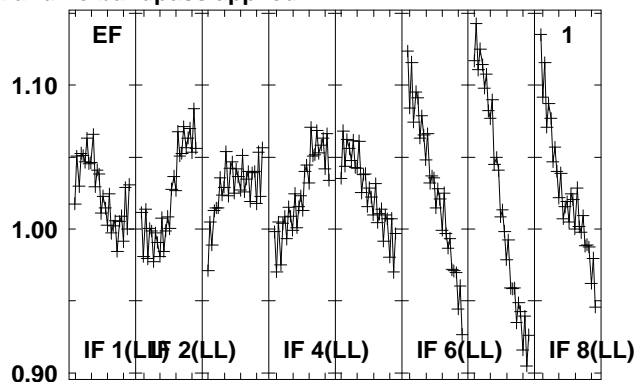
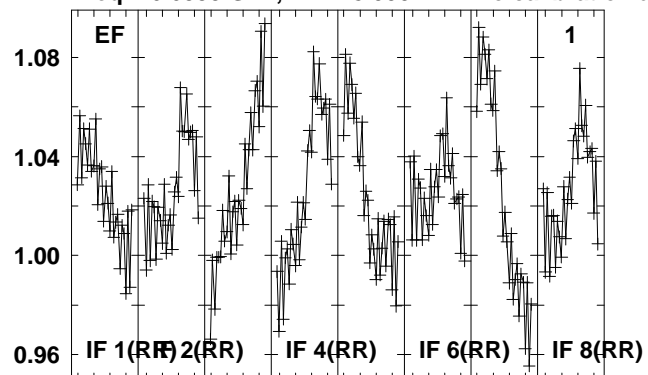

Lower frame: Real Jy
 Total-power spectrum Antenna: *
 Timerange: 00/14:41:40 to 00/14:43:08

Plot file version 188 created 15-MAR-2012 17:32:39

2114-G85 EZ020E 2.UVDATA.1

Freq = 6.6335 GHz, Bw = 8.000 MH No calibration applied and no bandpass applied

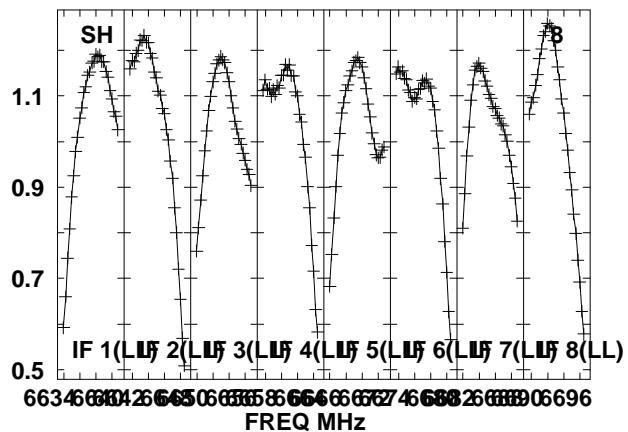
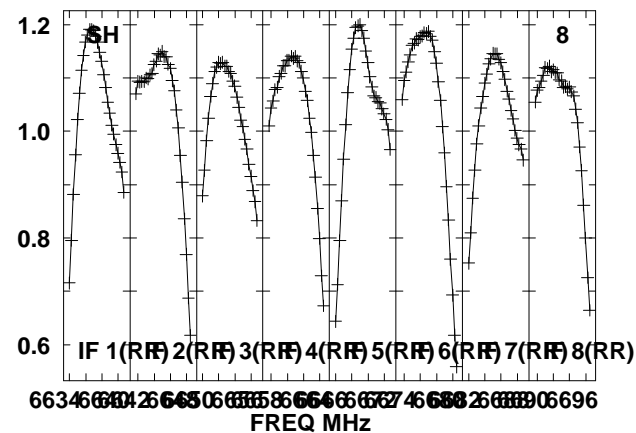
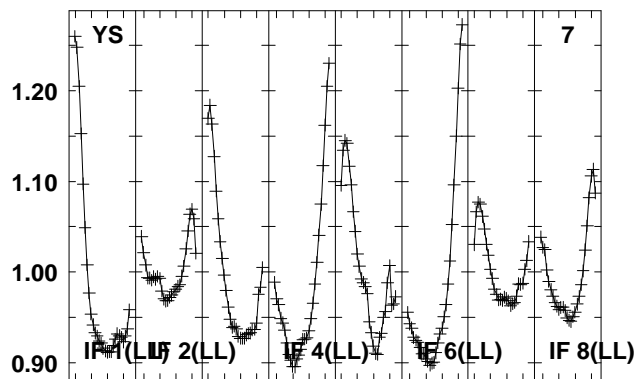
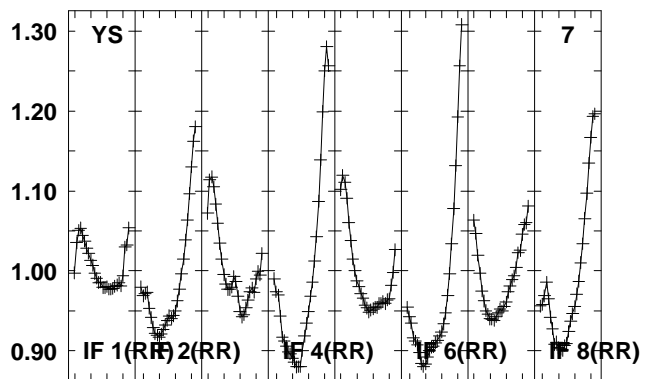
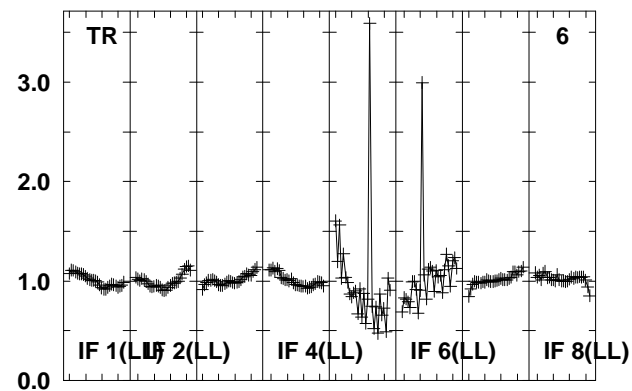
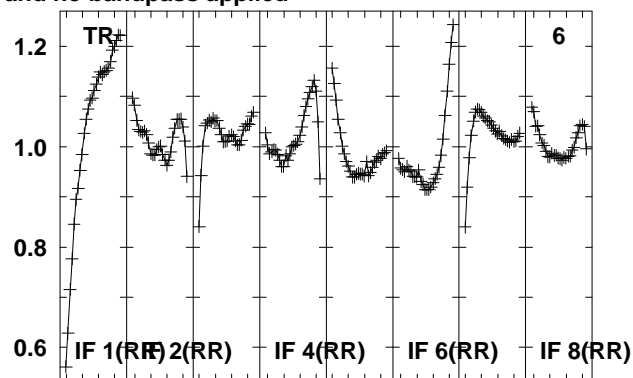
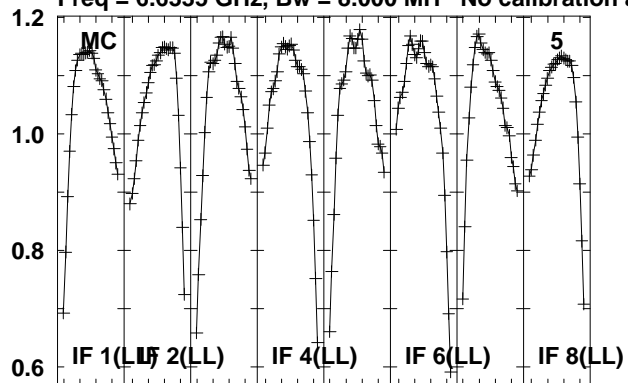

Lower frame: Real Jy

Total-power spectrum Antenna: *

Timerange: 00/14:41:40 to 00/14:43:08

Plot file version 190 created 15-MAR-2012 17:32:40

G85.40 EZ020E 2.UVDATA.1

Freq = 6.6335 GHz, Bw = 8.000 MH No calibration applied and no bandpass applied

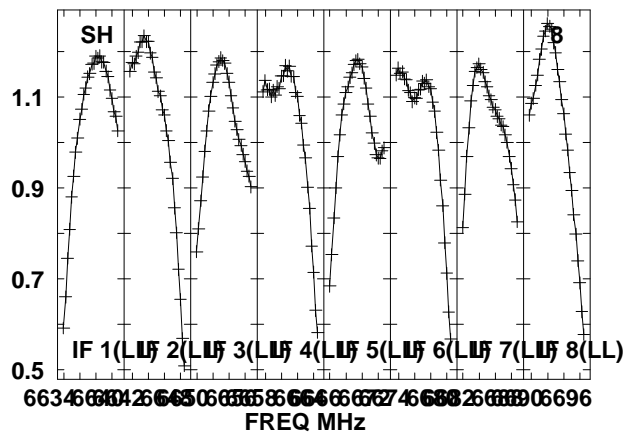
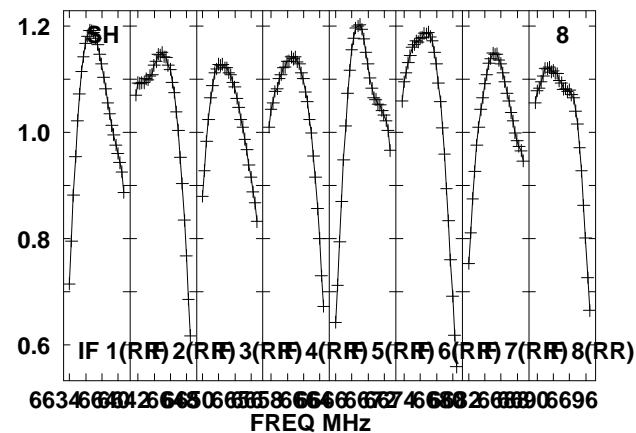
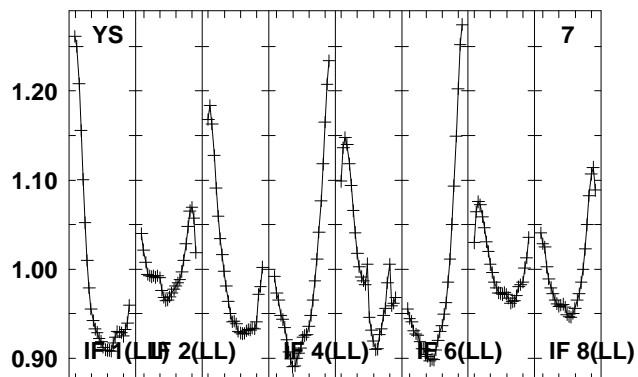
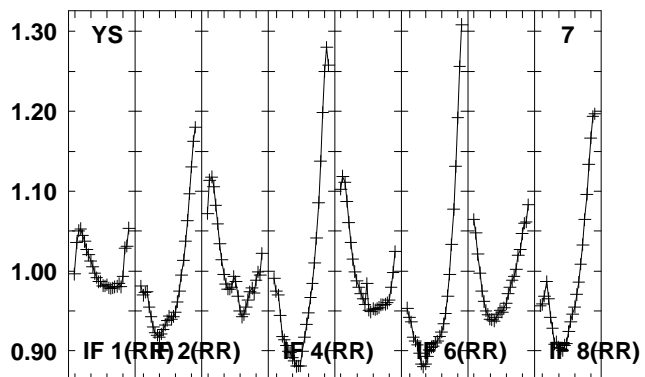
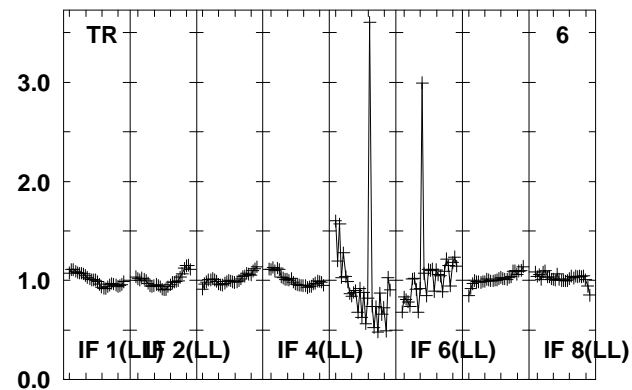
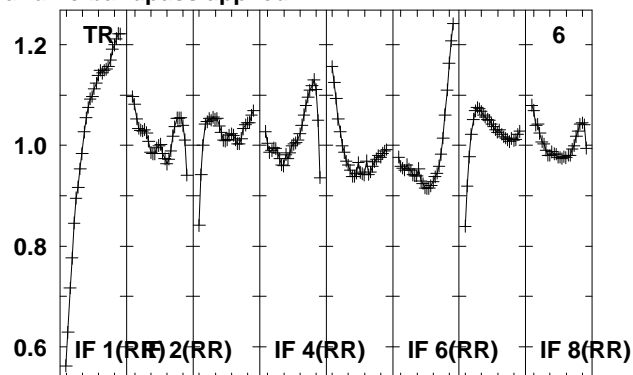
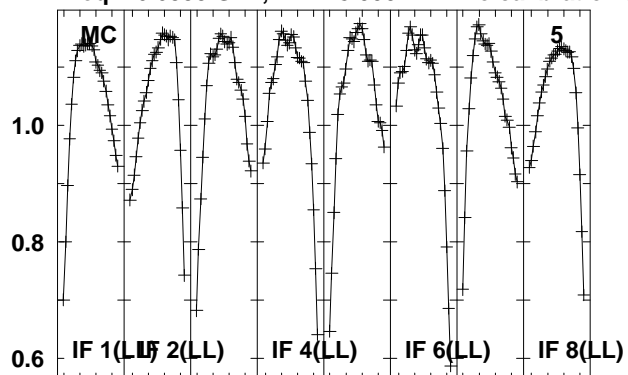

Lower frame: Real Jy
Total-power spectrum Antenna: *
Timerange: 00/14:43:10 to 00/14:44:38

Plot file version 191 created 15-MAR-2012 17:32:41
 2102-G85 EZ020E 2.UVDATA.1
 Freq = 6.6335 GHz, Bw = 8.000 MH No calibration applied and no bandpass applied

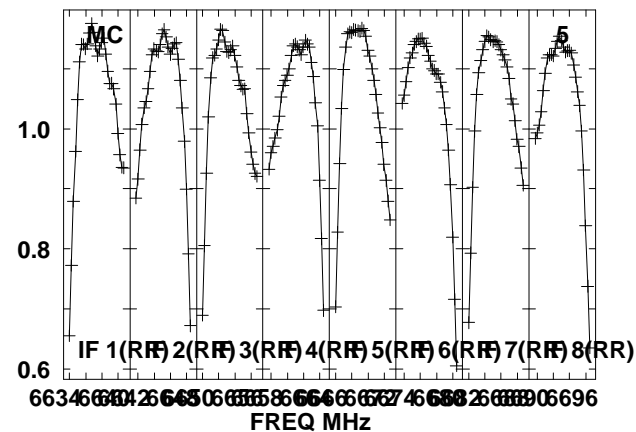
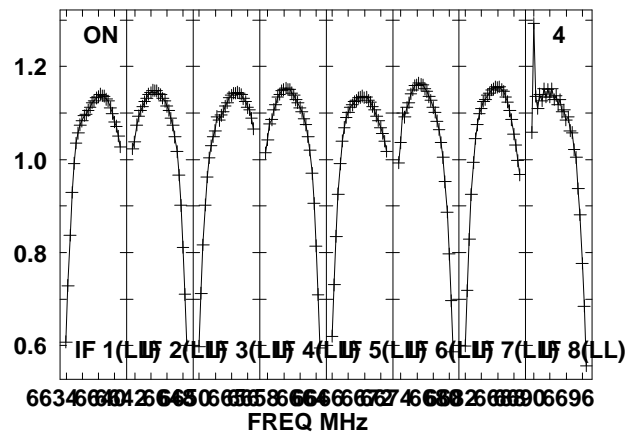
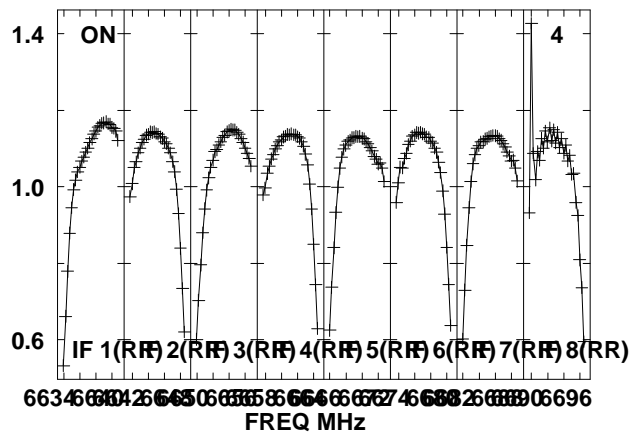
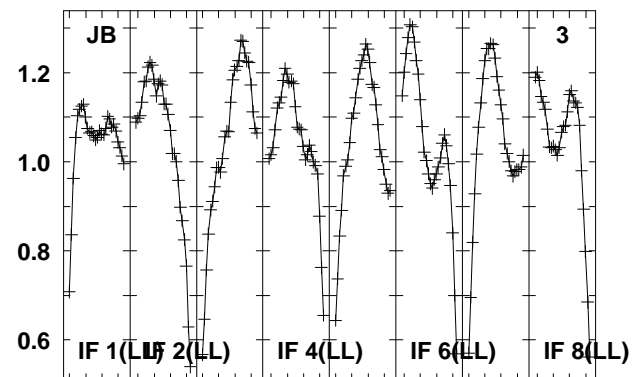
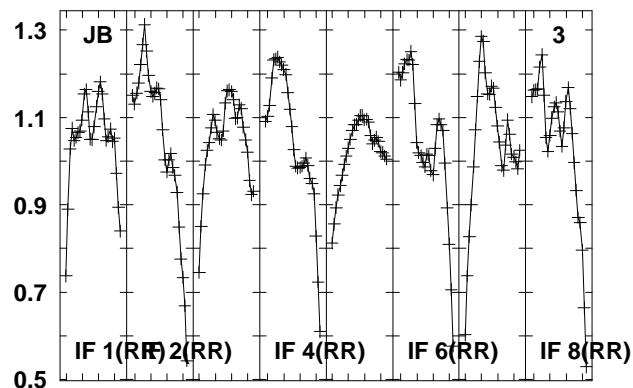
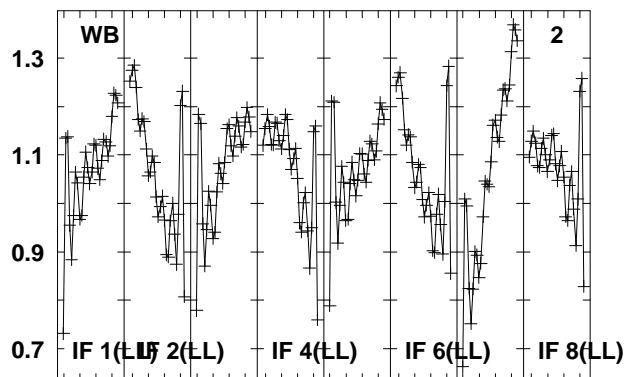
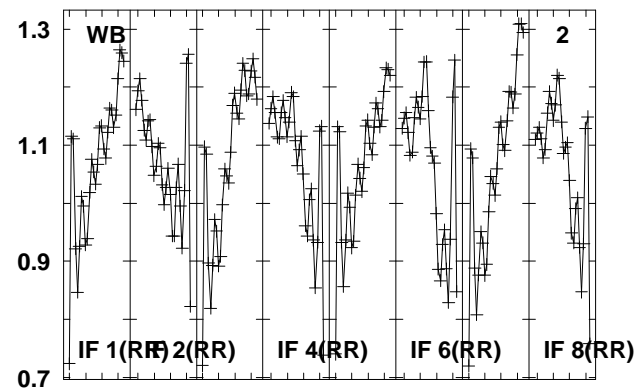
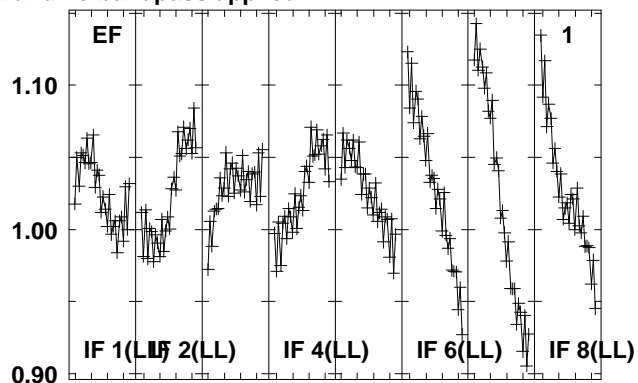
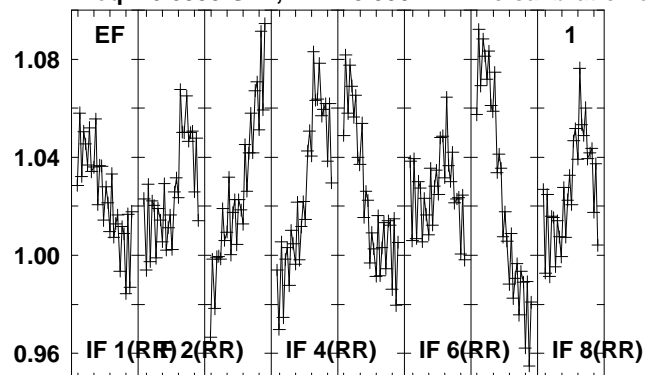

Lower frame: Real Jy
 Total-power spectrum Antenna: *
 Timerange: 00/14:44:41 to 00/14:46:09

Plot file version 192 created 15-MAR-2012 17:32:42

2102-G85 EZ020E 2.UVDATA.1

Freq = 6.6335 GHz, Bw = 8.000 MH No calibration applied and no bandpass applied

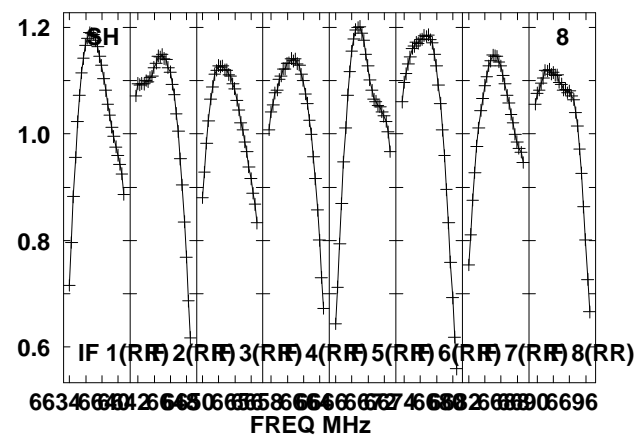
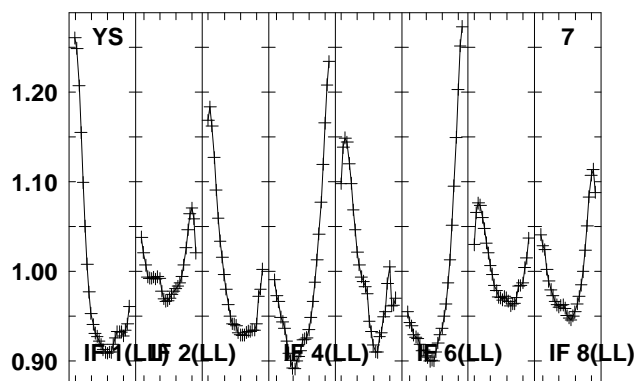
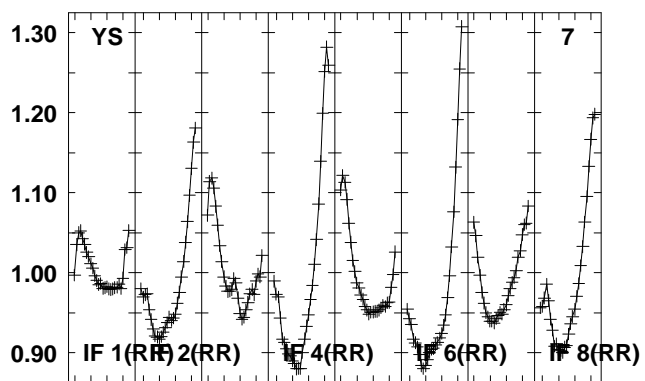
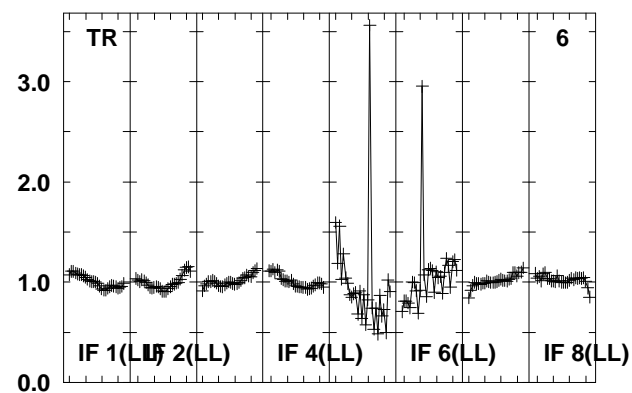
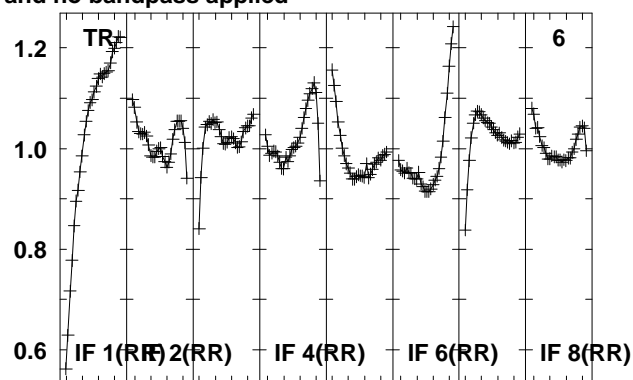
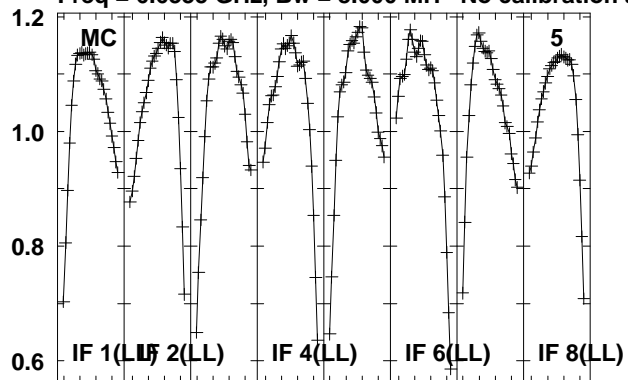

Plot file version 194 created 15-MAR-2012 17:32:43

G85.40 EZ020E 2.UVDATA.1

Freq = 6.6335 GHz, Bw = 8.000 MH No calibration applied and no bandpass applied

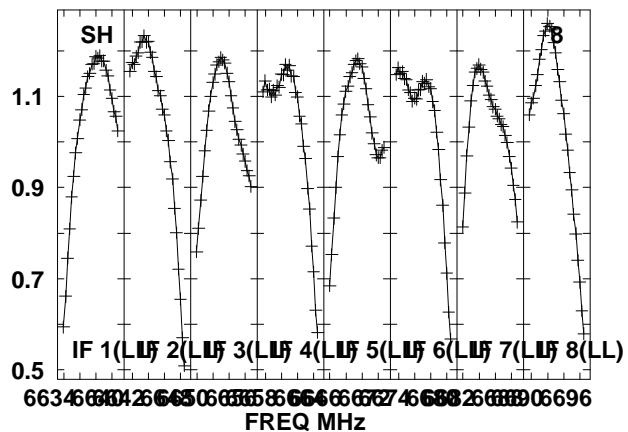
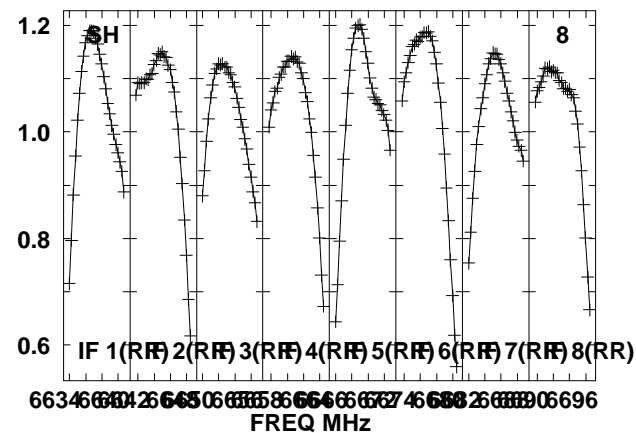
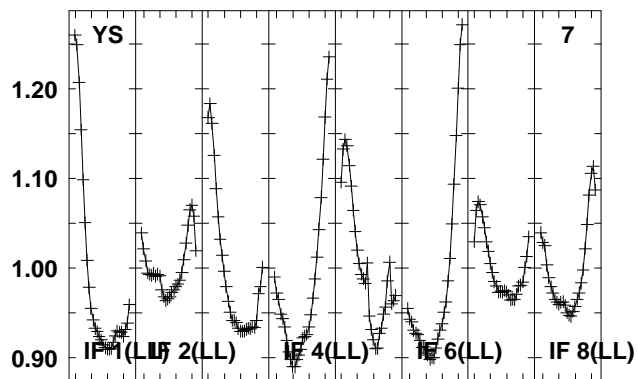
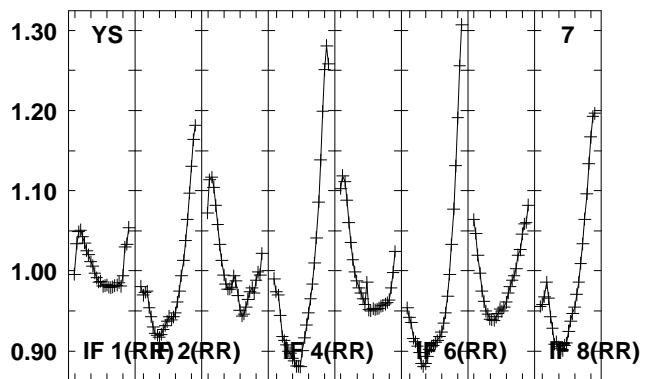
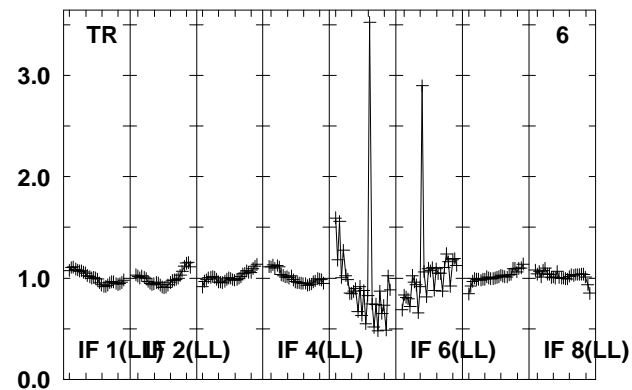
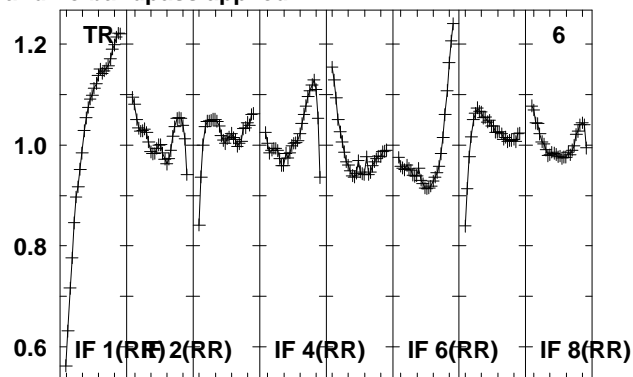
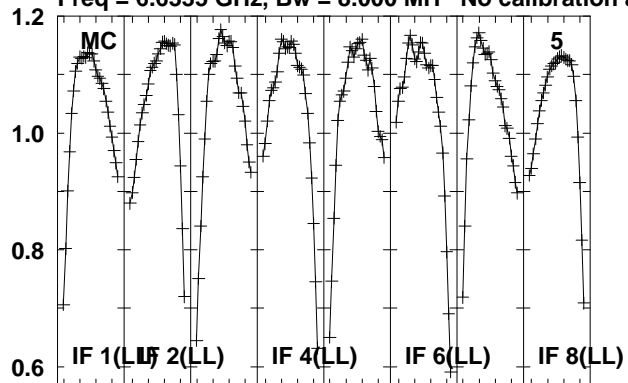

Lower frame: Real Jy

Total-power spectrum Antenna: *

Timerange: 00/14:46:51 to 00/14:47:50

Plot file version 195 created 15-MAR-2012 17:32:43

2114-G85 EZ020E 2.UVDATA.1

Freq = 6.6335 GHz, Bw = 8.000 MH No calibration applied and no bandpass applied

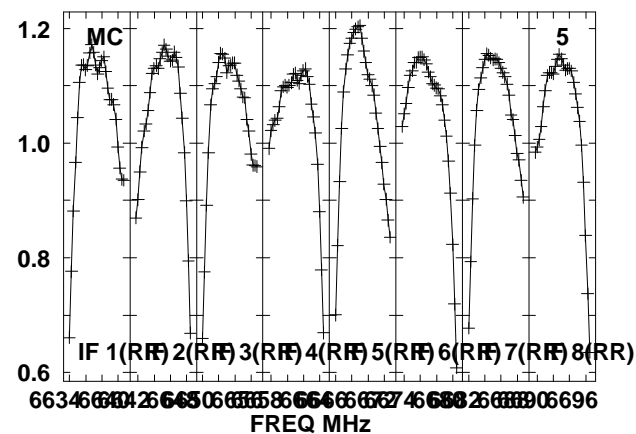
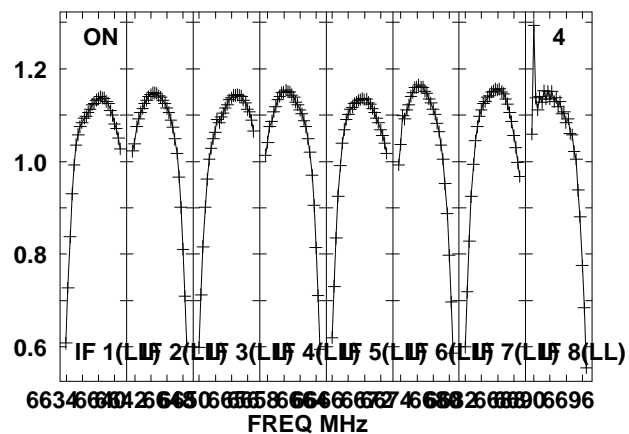
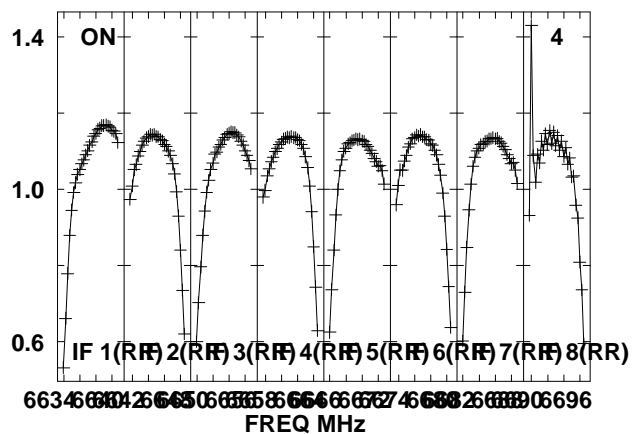
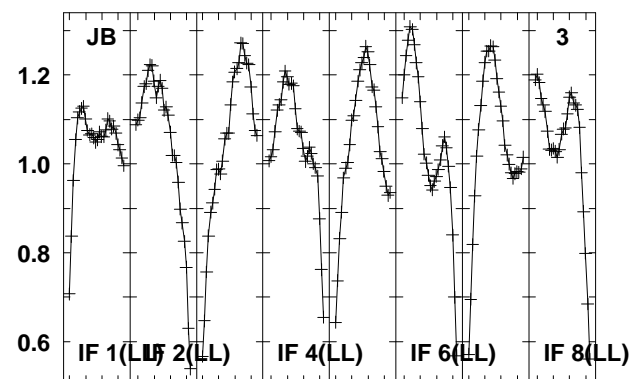
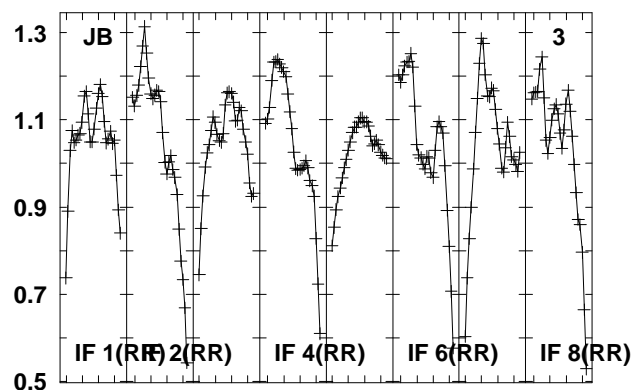
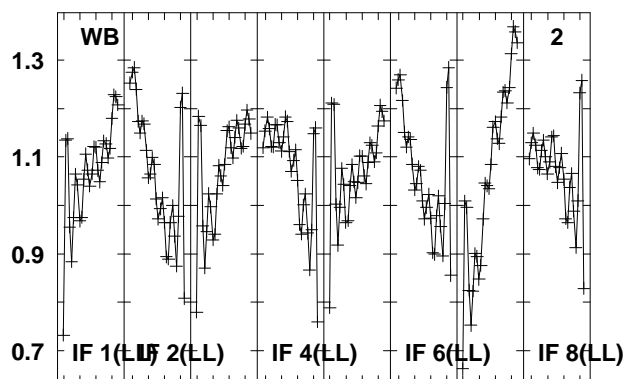
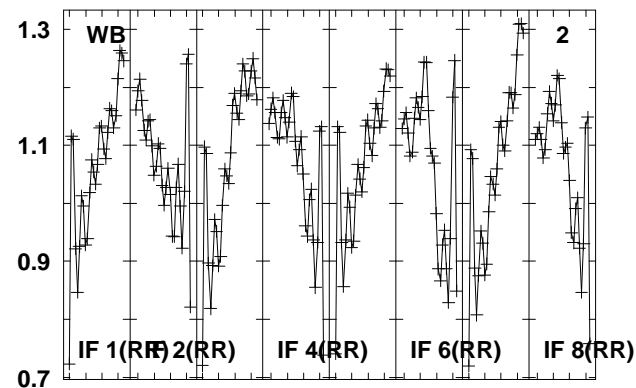
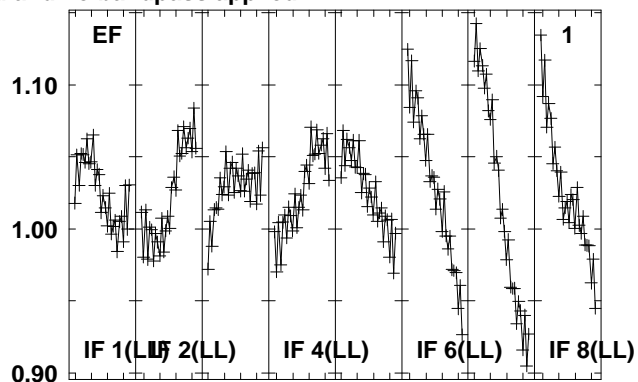
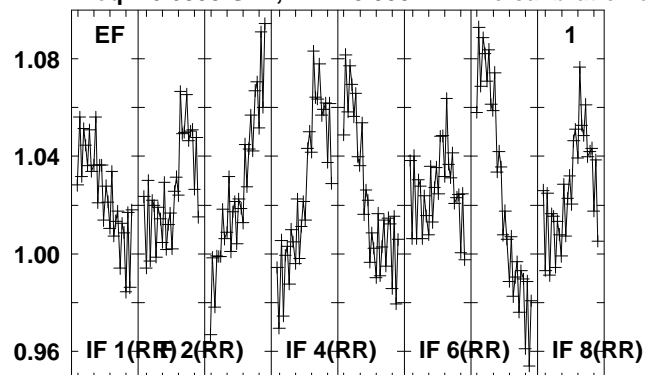

Lower frame: Real Jy
Total-power spectrum Antenna: *
Timerange: 00/14:47:51 to 00/14:49:19

Plot file version 196 created 15-MAR-2012 17:32:44

2114-G85 EZ020E 2.UVDATA.1

Freq = 6.6335 GHz, Bw = 8.000 MH No calibration applied and no bandpass applied

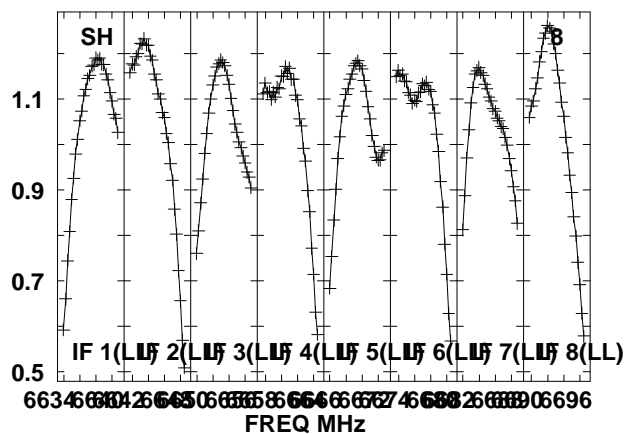
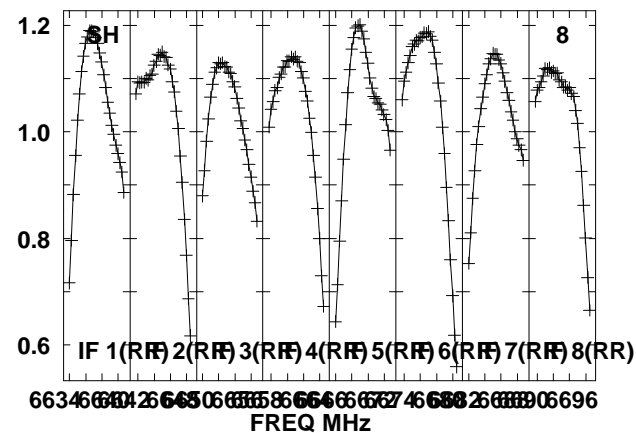
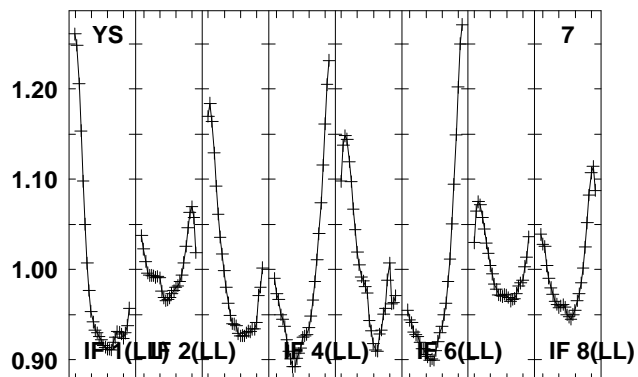
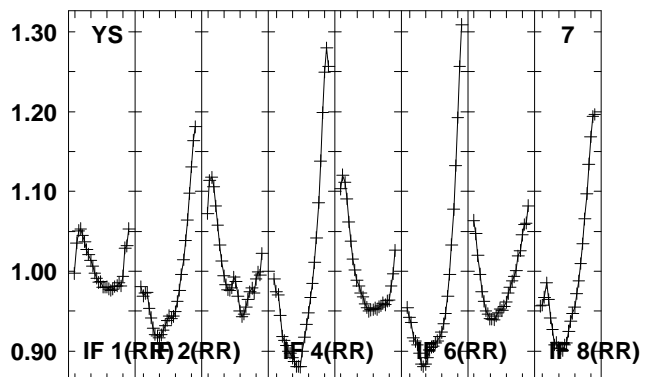
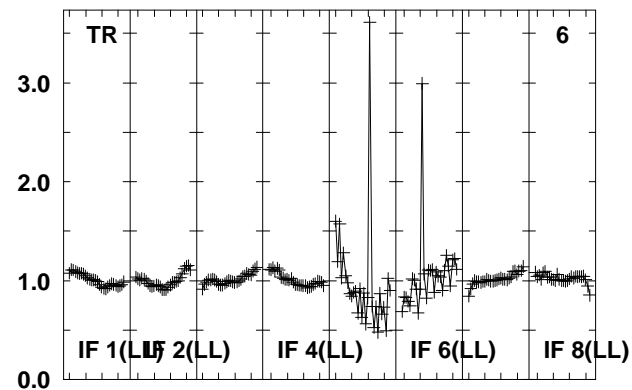
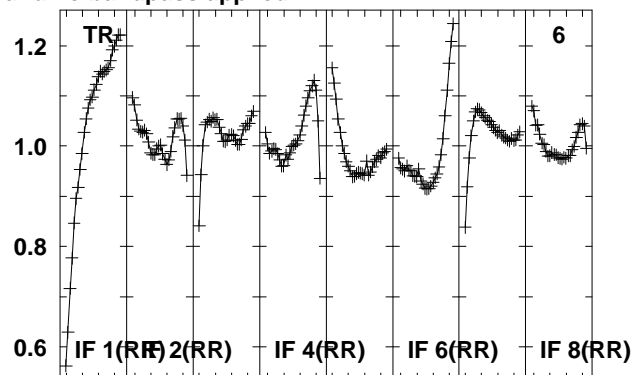
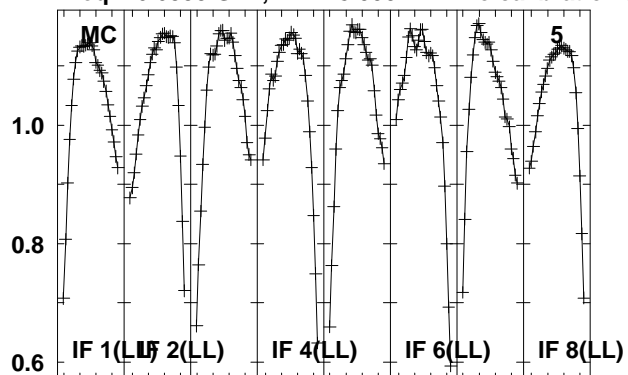

Lower frame: Real Jy

Total-power spectrum Antenna: *

Timerange: 00/14:47:51 to 00/14:49:19

Plot file version 197 created 15-MAR-2012 17:32:45

G85.40 EZ020E 2.UVDATA.1

Freq = 6.6335 GHz, Bw = 8.000 MH No calibration applied and no bandpass applied

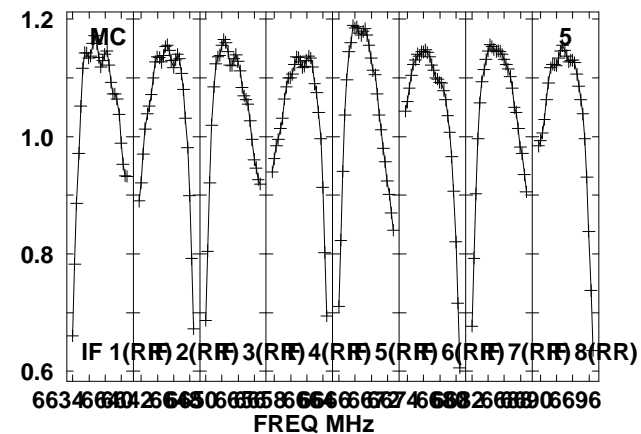
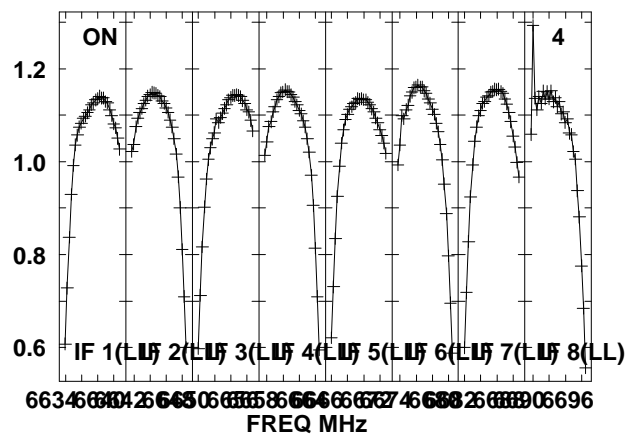
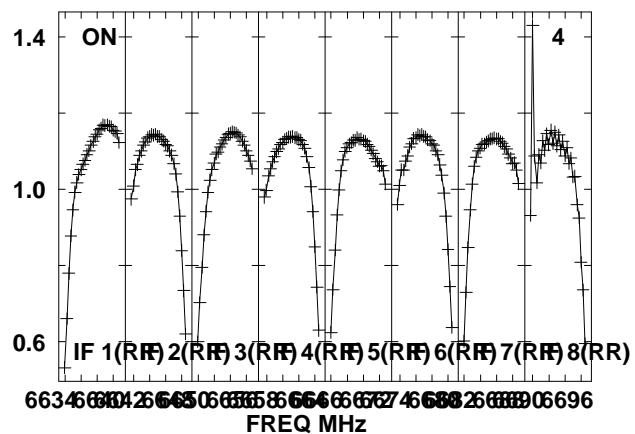
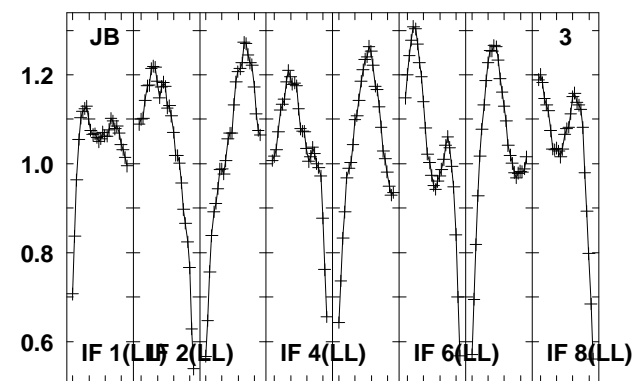
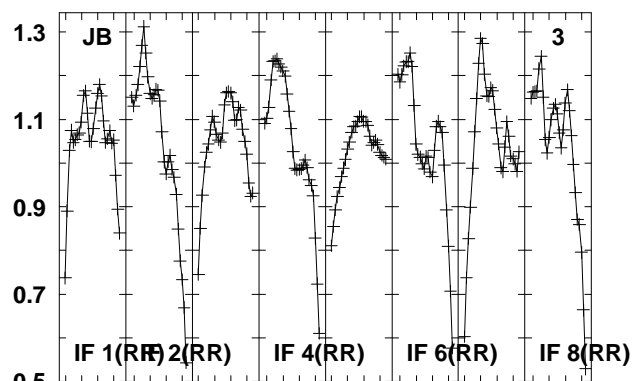
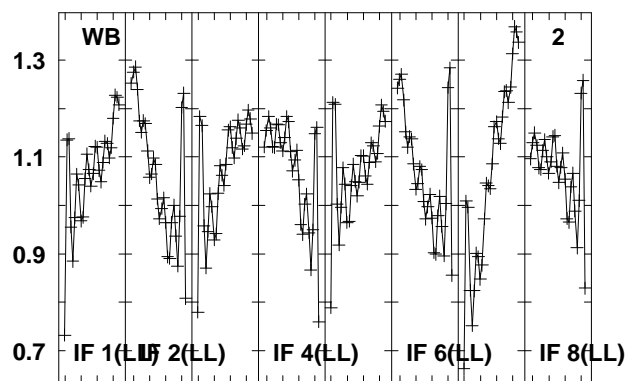
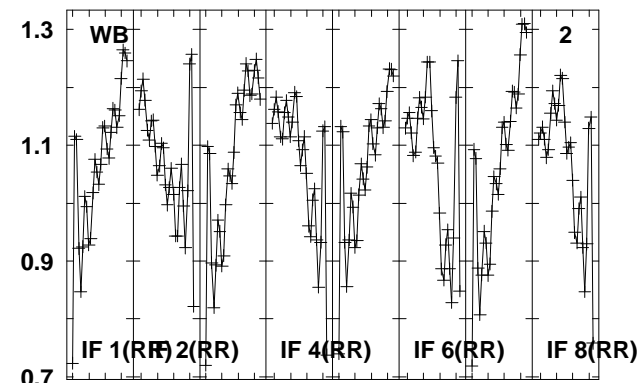
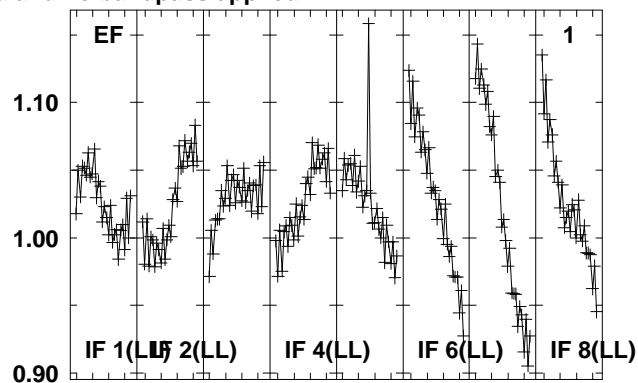
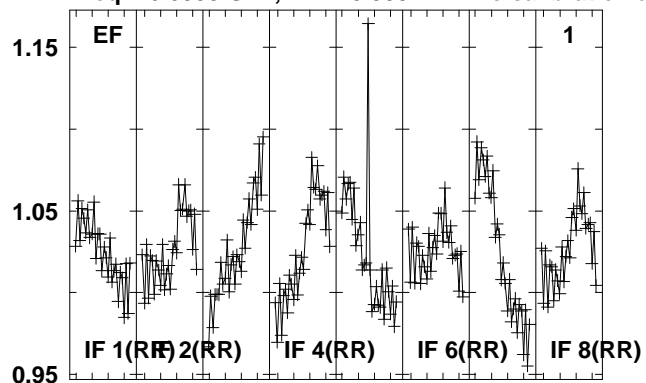

Lower frame: Real Jy
Total-power spectrum Antenna: *
Timerange: 00/14:49:22 to 00/14:50:50

Plot file version 198 created 15-MAR-2012 17:32:46

G85.40 EZ020E 2.UVDATA.1

Freq = 6.6335 GHz, Bw = 8.000 MH No calibration applied and no bandpass applied

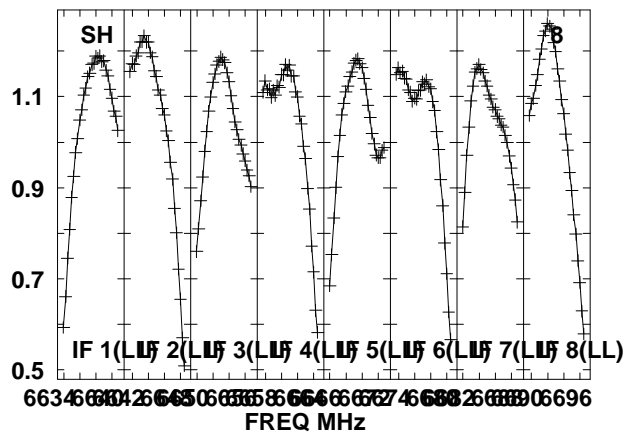
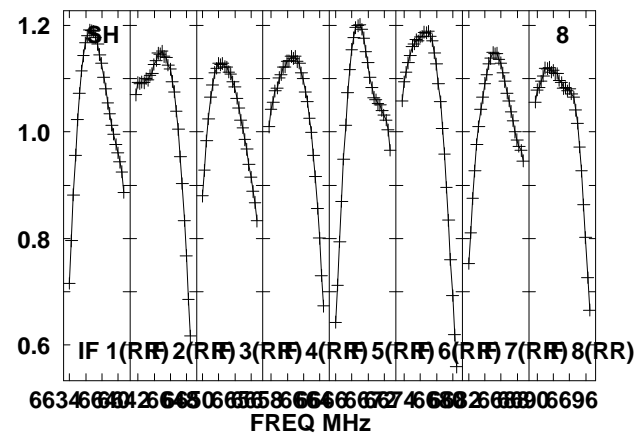
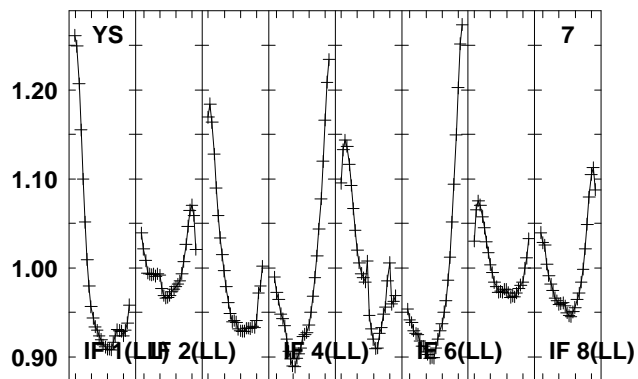
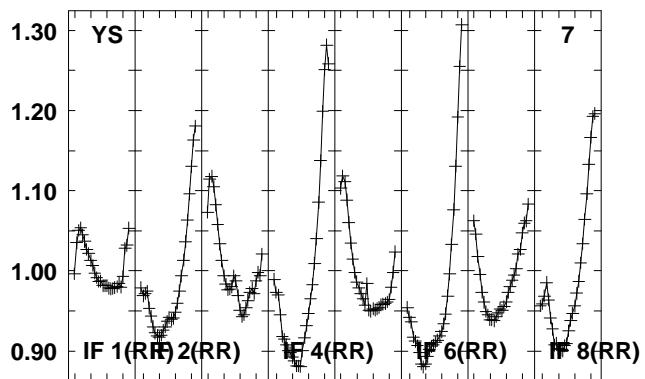
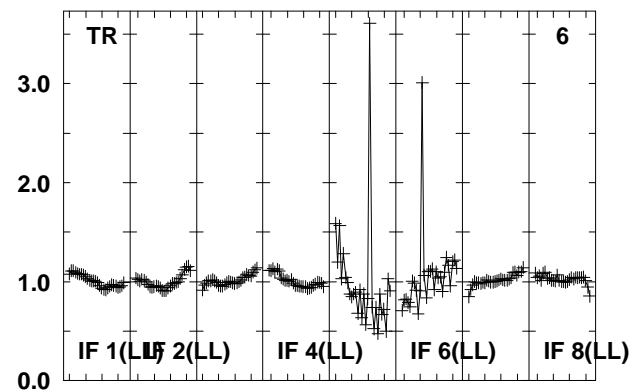
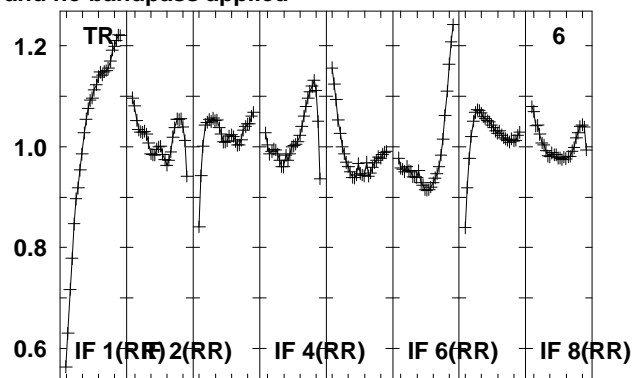
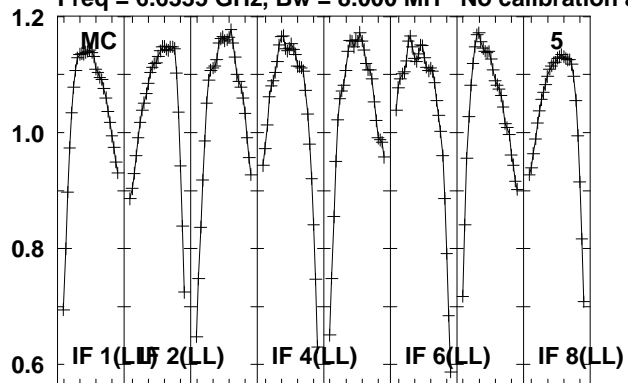

Lower frame: Real Jy

Total-power spectrum Antenna: *

Timerange: 00/14:49:22 to 00/14:50:50

Plot file version 199 created 15-MAR-2012 17:32:47

2102-G85 EZ020E 2.UVDATA.1

Freq = 6.6335 GHz, Bw = 8.000 MH No calibration applied and no bandpass applied

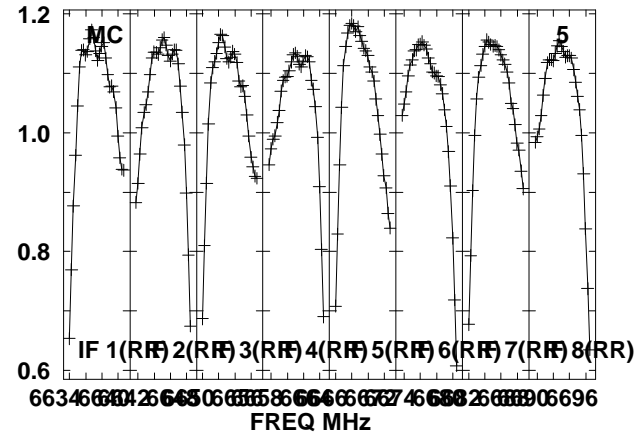
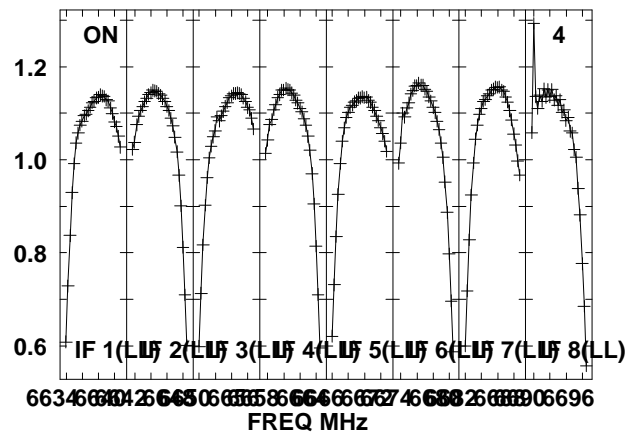
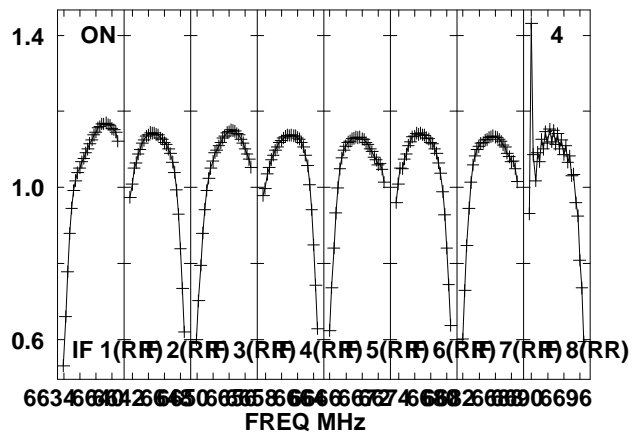
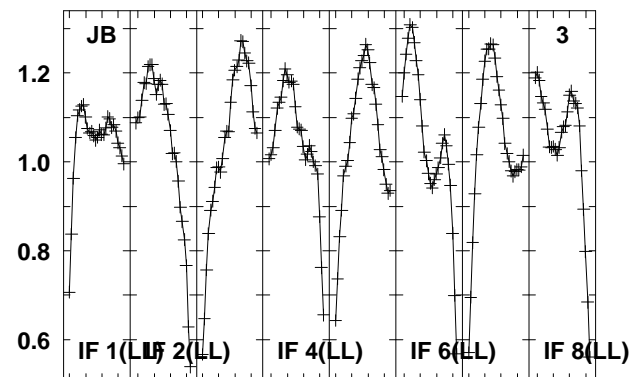
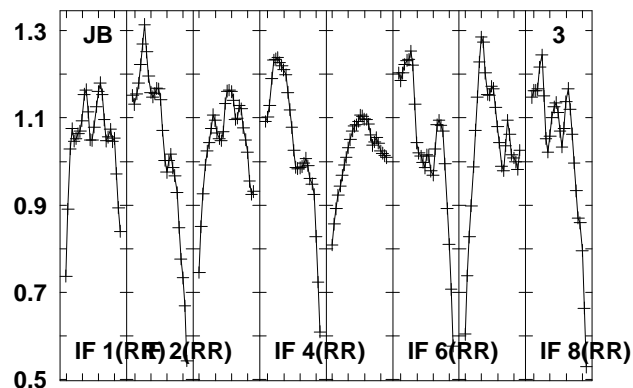
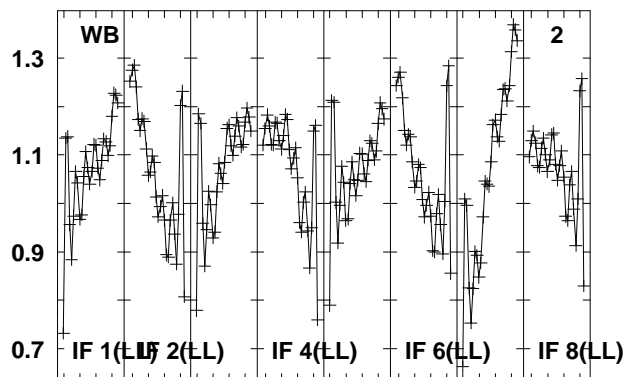
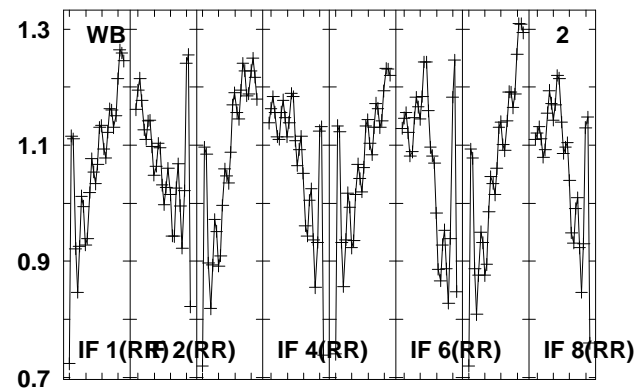
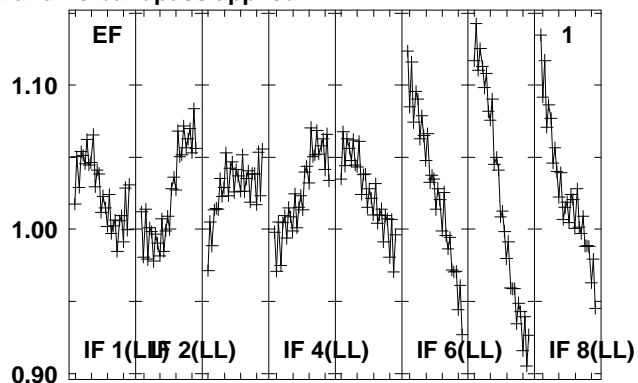
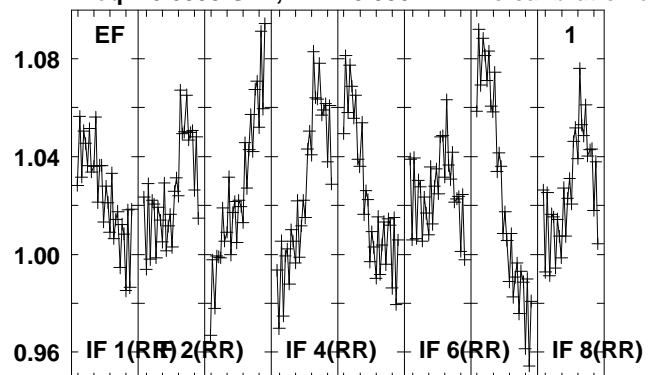

Lower frame: Real Jy
Total-power spectrum Antenna: *
Timerange: 00/14:50:52 to 00/14:52:20

Plot file version 200 created 15-MAR-2012 17:32:47

2102-G85 EZ020E 2.UVDATA.1

Freq = 6.6335 GHz, Bw = 8.000 MH No calibration applied and no bandpass applied

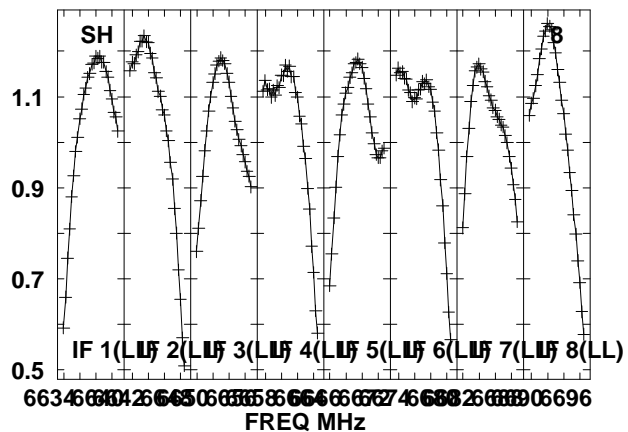
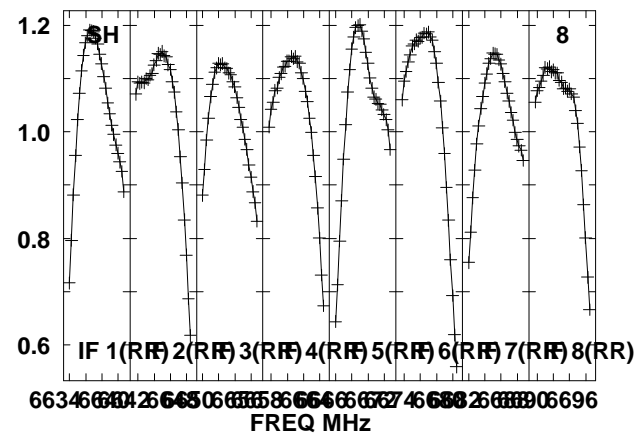
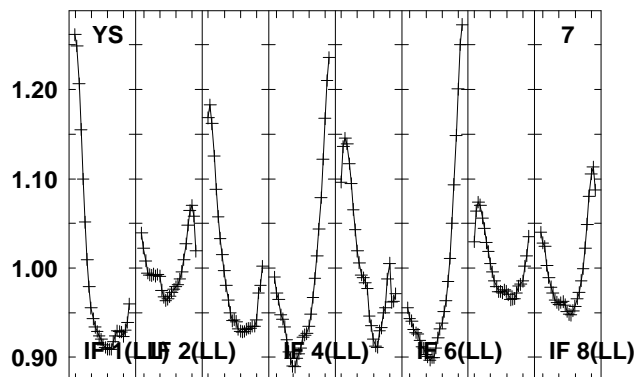
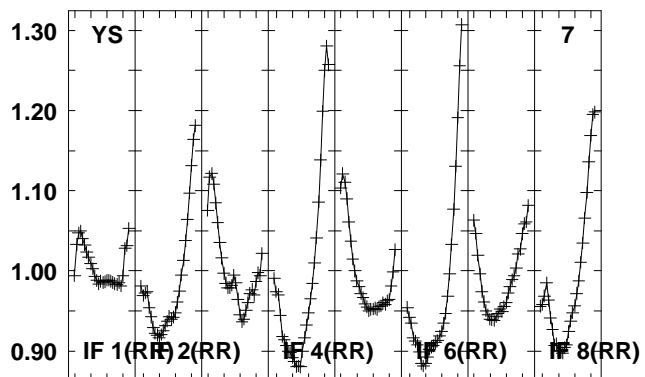
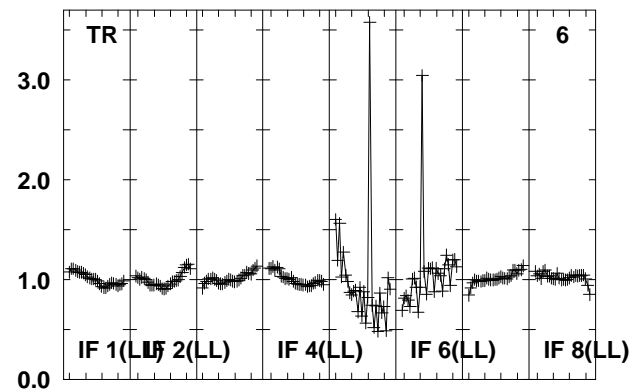
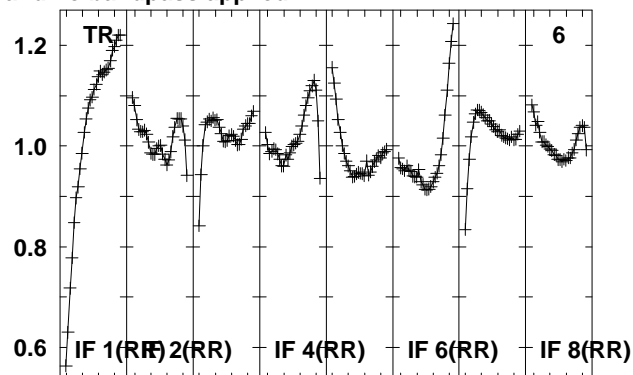
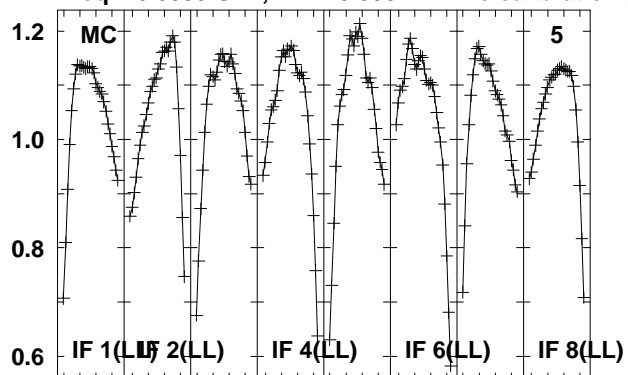

Lower frame: Real Jy

Total-power spectrum Antenna: *

Timerange: 00/14:50:52 to 00/14:52:20

Plot file version 202 created 15-MAR-2012 17:32:49

G85.40 EZ020E 2.UVDATA.1

Freq = 6.6335 GHz, Bw = 8.000 MH No calibration applied and no bandpass applied

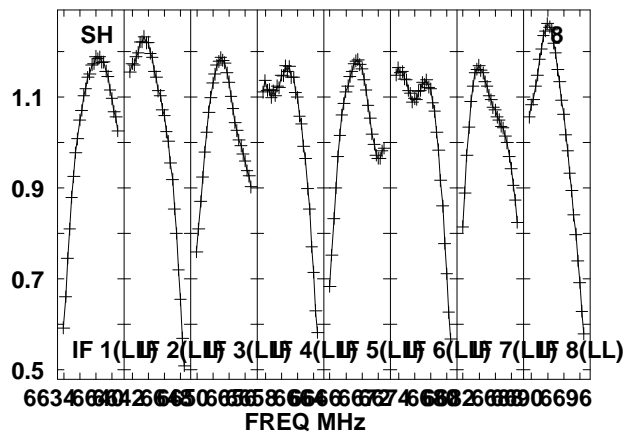
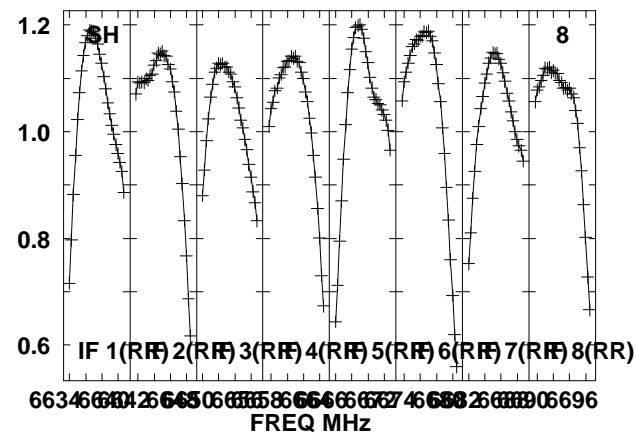
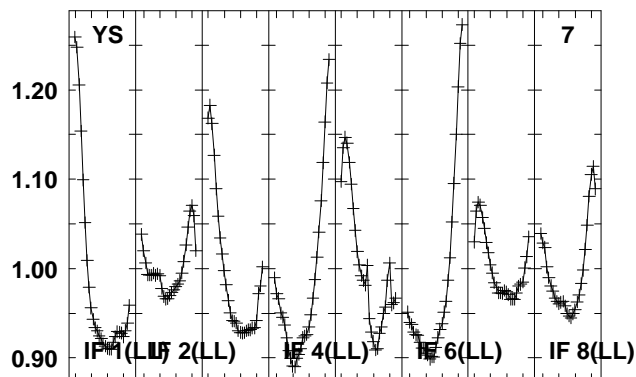
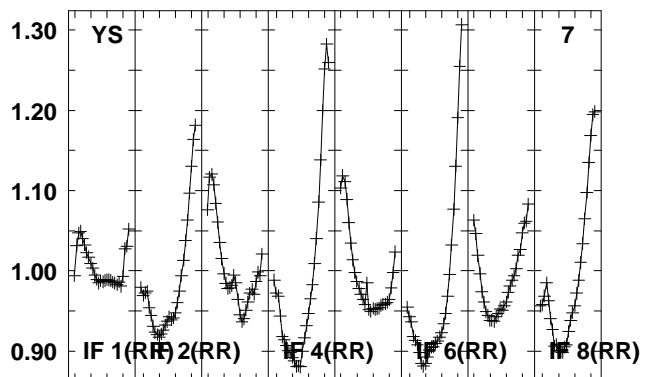
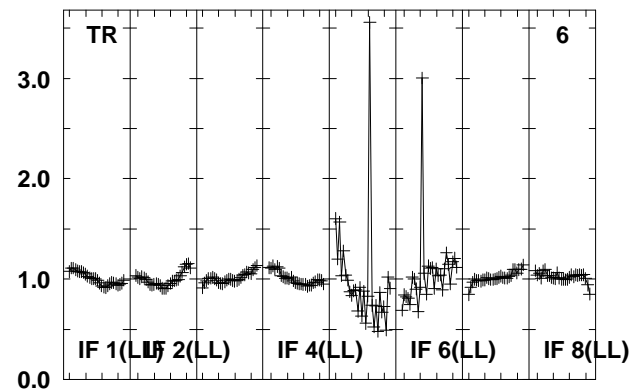
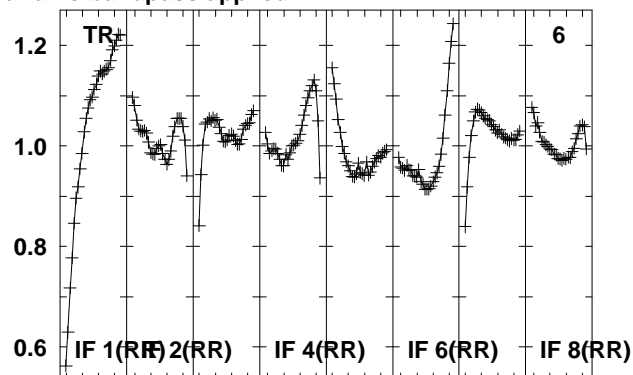
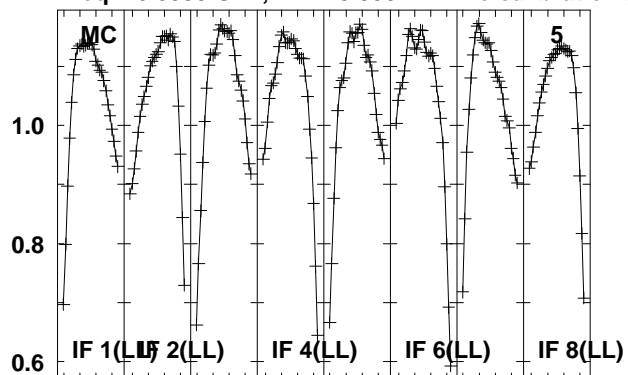

Lower frame: Real Jy
Total-power spectrum Antenna: *
Timerange: 00/14:52:21 to 00/14:53:49

Plot file version 203 created 15-MAR-2012 17:32:50

2114-G85 EZ020E 2.UVDATA.1

Freq = 6.6335 GHz, Bw = 8.000 MH No calibration applied and no bandpass applied

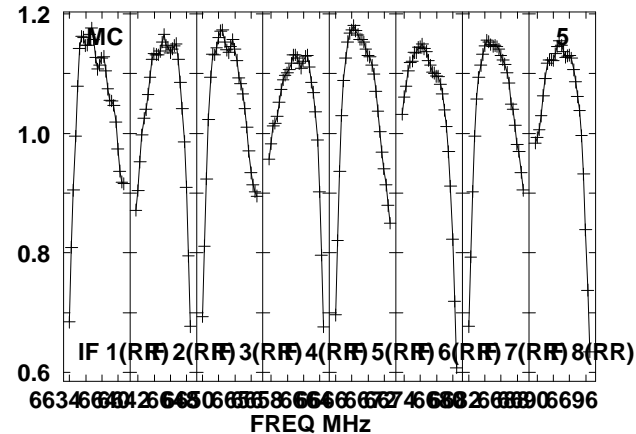
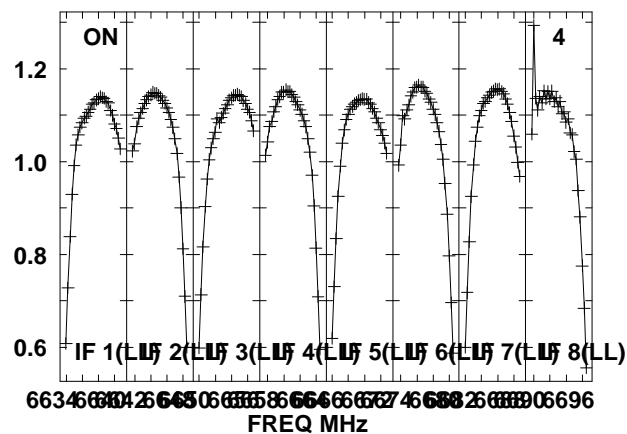
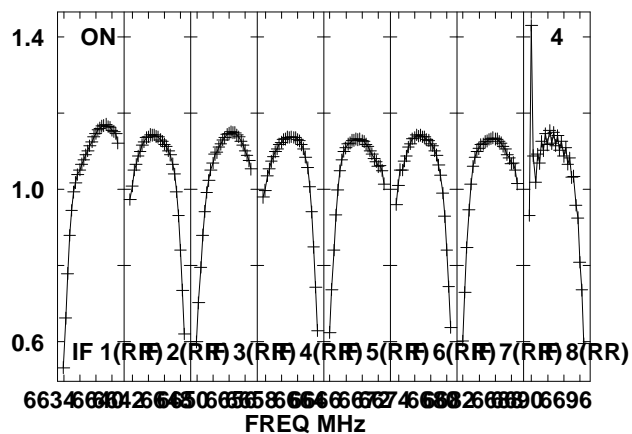
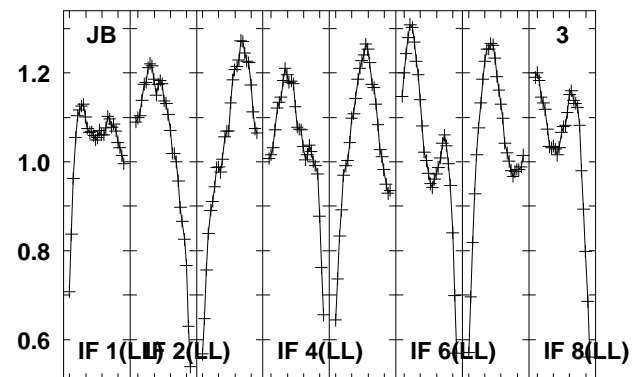
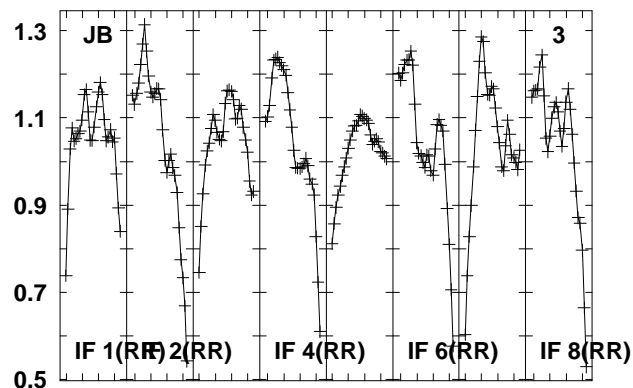
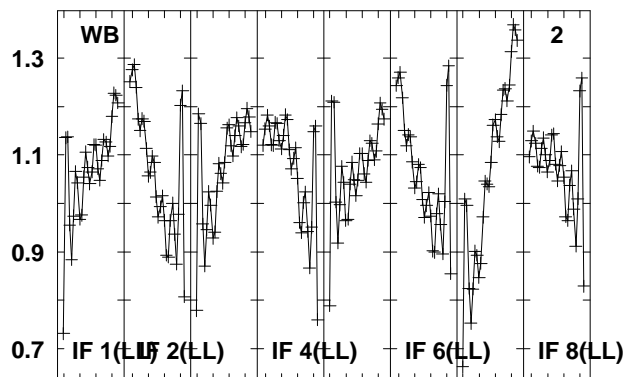
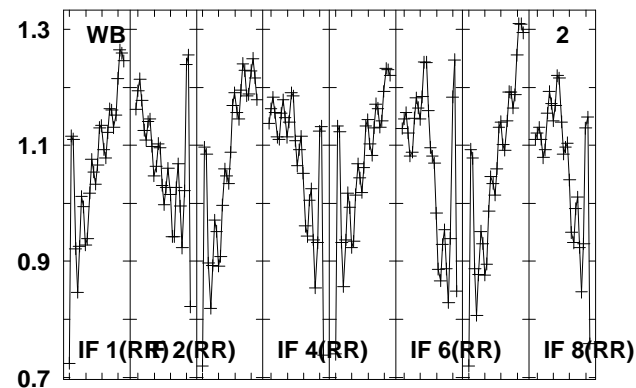
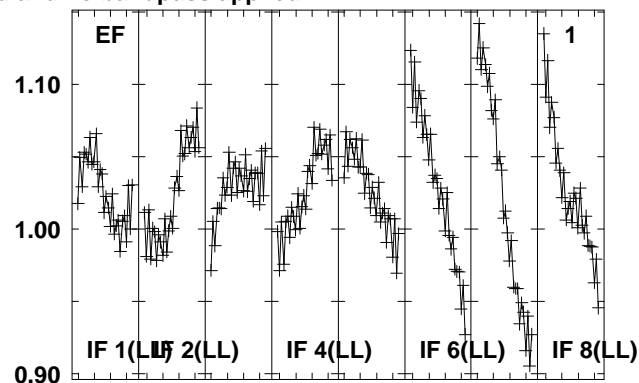
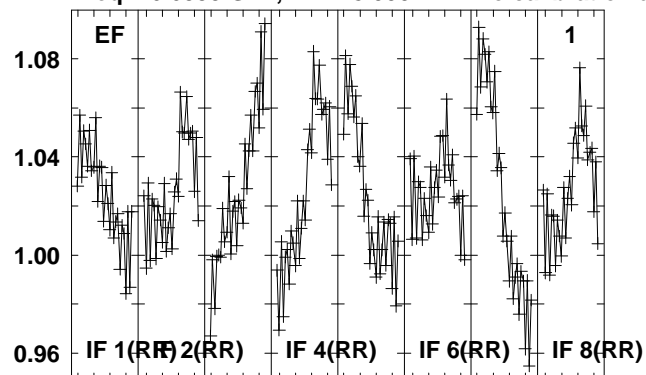

Lower frame: Real Jy
Total-power spectrum Antenna: *
Timerange: 00/14:53:51 to 00/14:55:19

Plot file version 204 created 15-MAR-2012 17:32:50

2114-G85 EZ020E 2.UVDATA.1

Freq = 6.6335 GHz, Bw = 8.000 MH No calibration applied and no bandpass applied

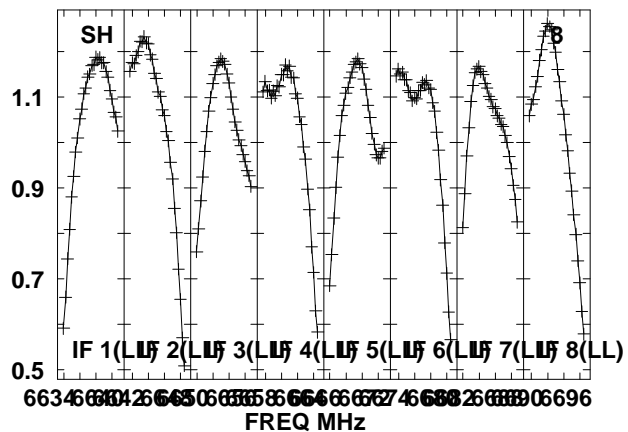
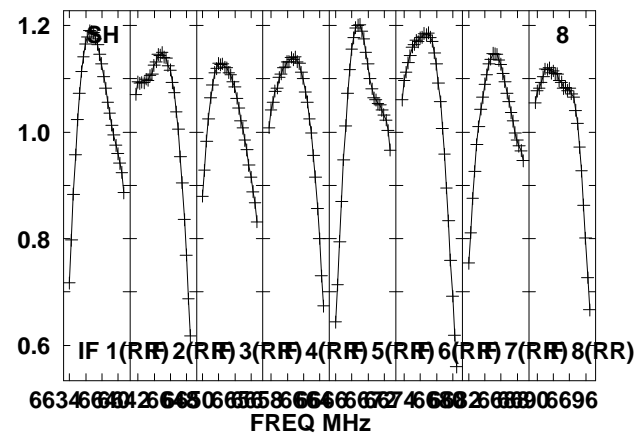
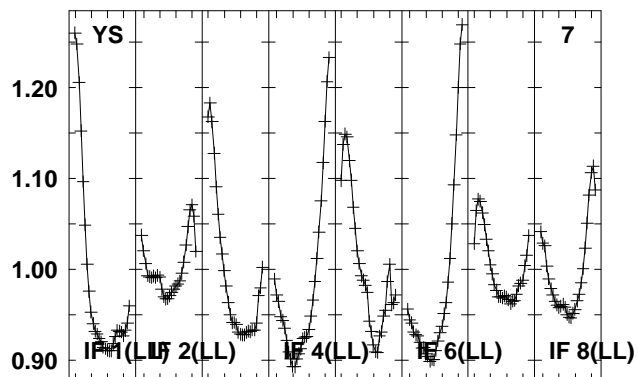
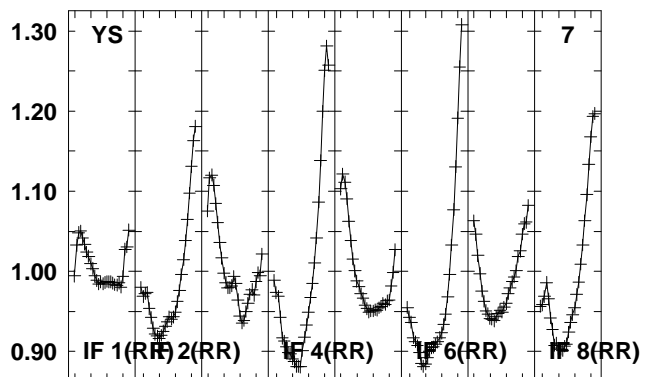
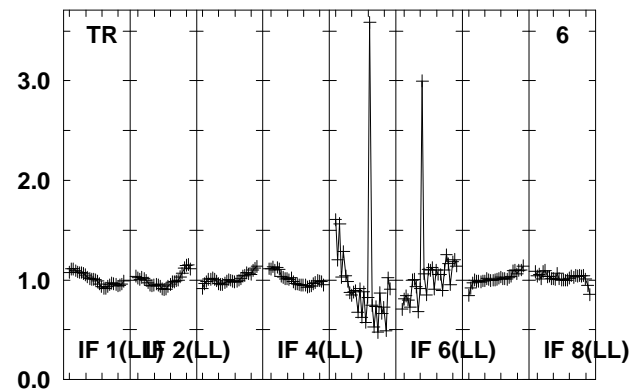
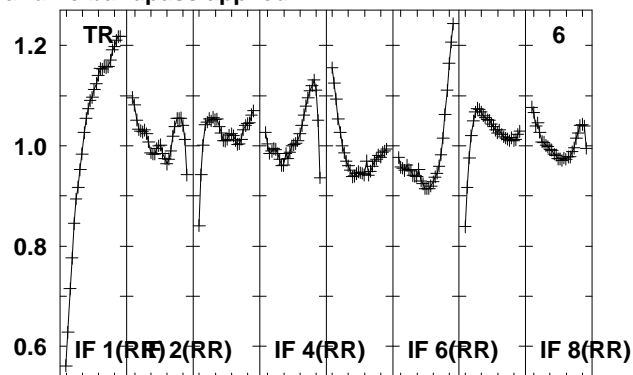
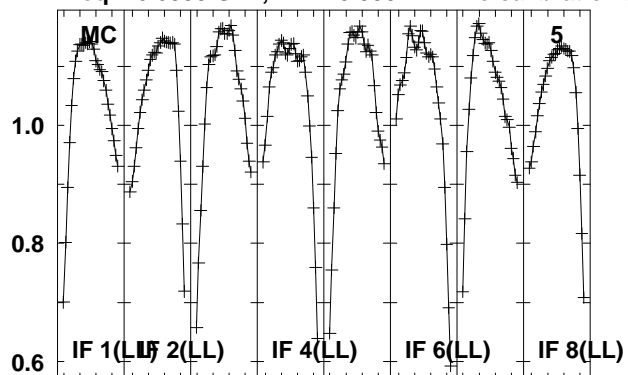

Lower frame: Real Jy

Total-power spectrum Antenna: *

Timerange: 00/14:53:51 to 00/14:55:19

Plot file version 205 created 15-MAR-2012 17:32:51

G85.40 EZ020E 2.UVDATA.1

Freq = 6.6335 GHz, Bw = 8.000 MH No calibration applied and no bandpass applied

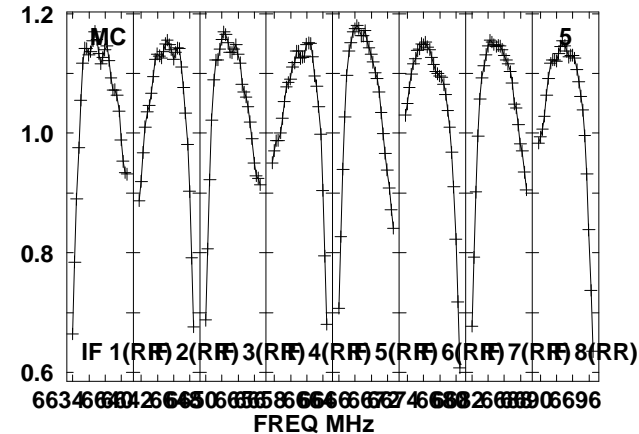
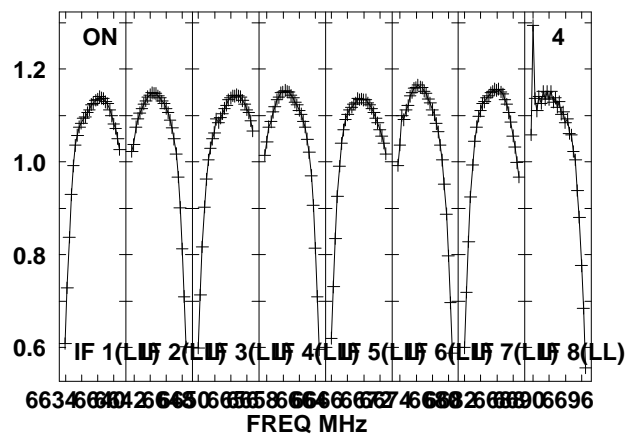
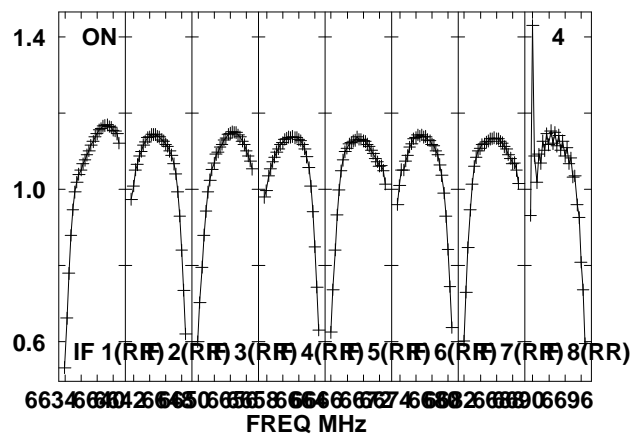
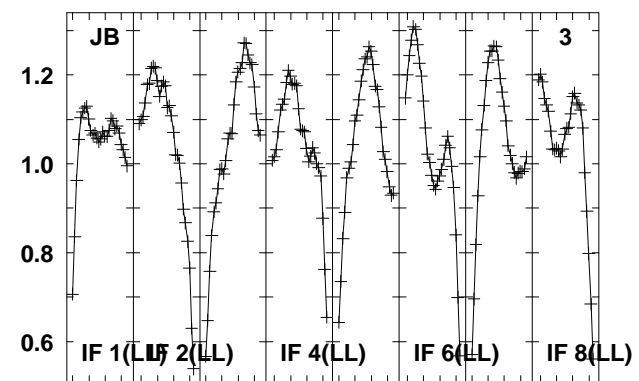
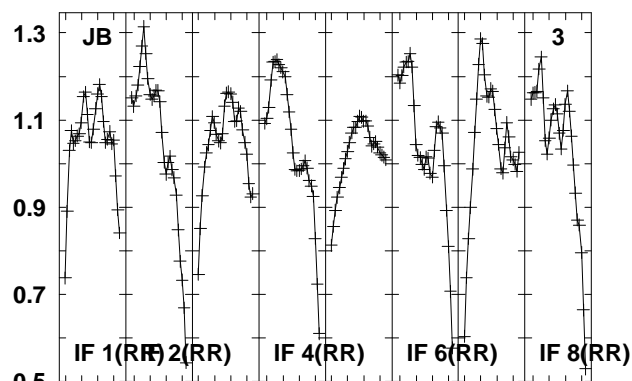
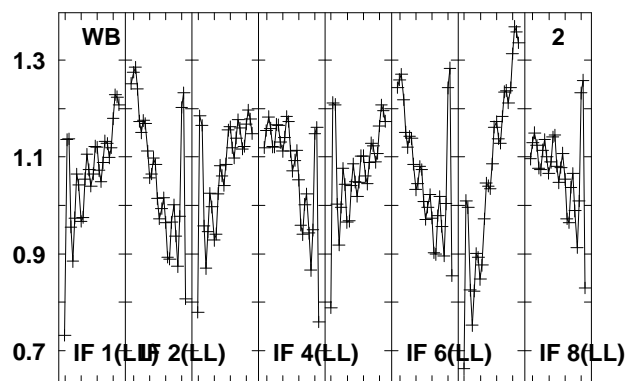
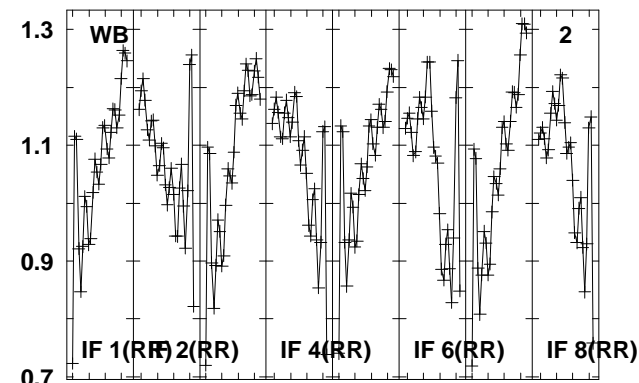
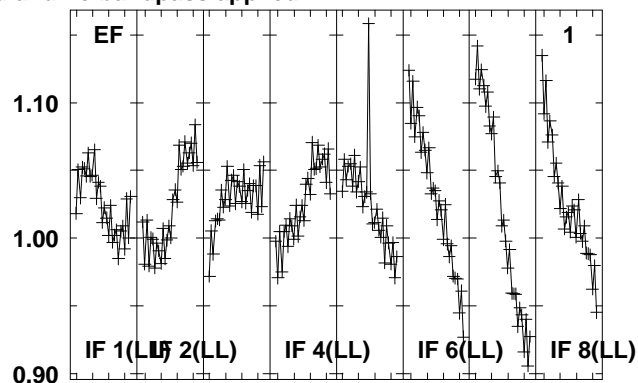
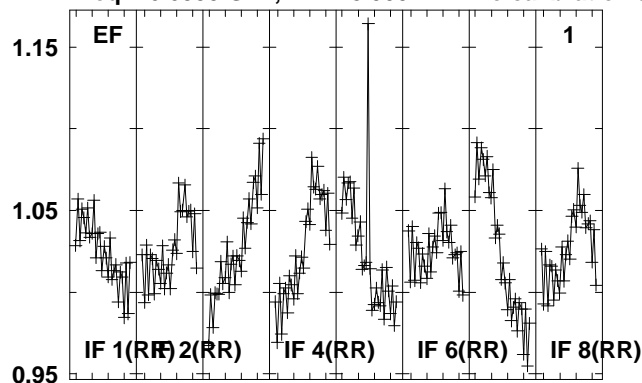

Lower frame: Real Jy

Total-power spectrum Antenna: *

Timerange: 00/14:55:22 to 00/14:56:50

Plot file version 206 created 15-MAR-2012 17:32:52

G85.40 EZ020E 2.UVDATA.1

Freq = 6.6335 GHz, Bw = 8.000 MH No calibration applied and no bandpass applied

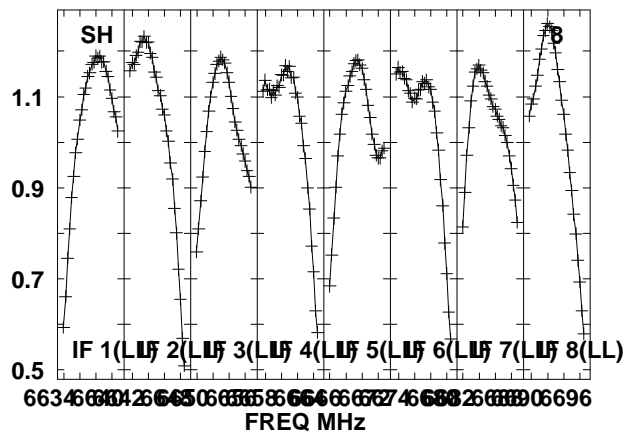
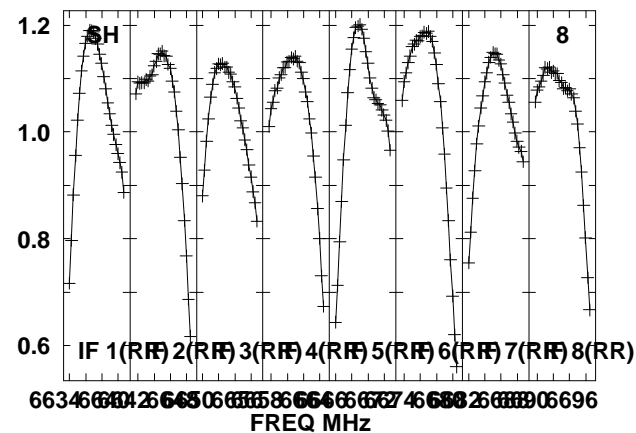
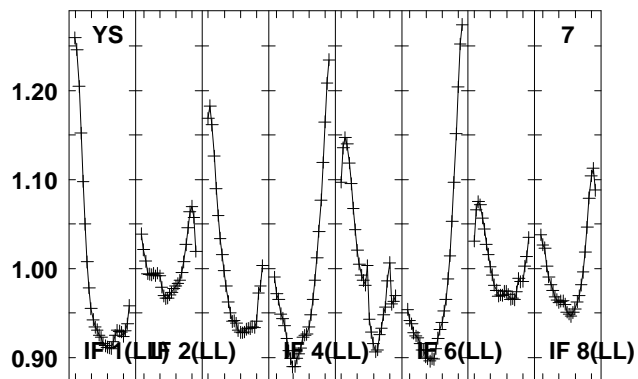
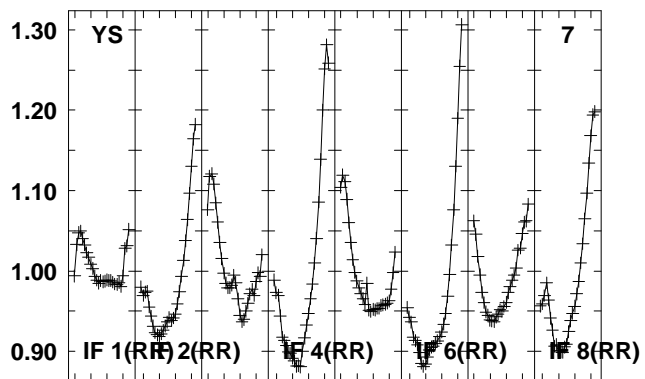
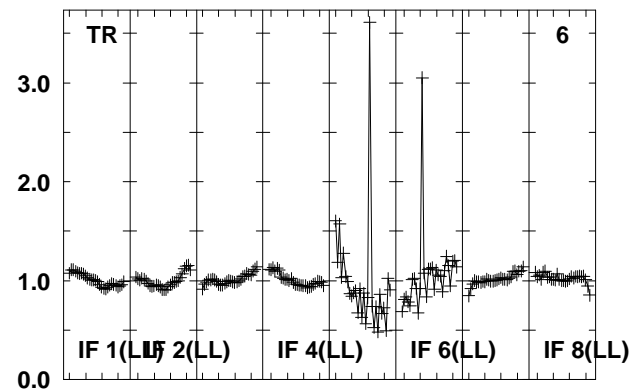
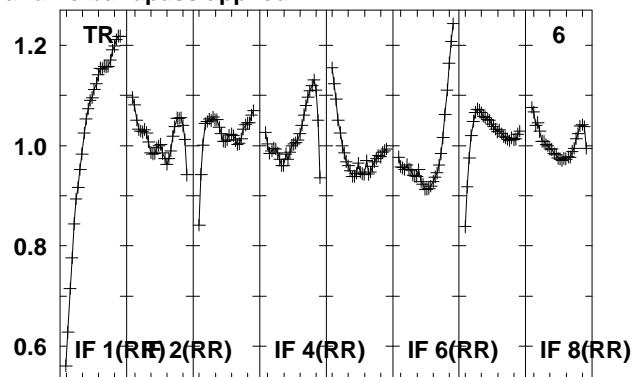
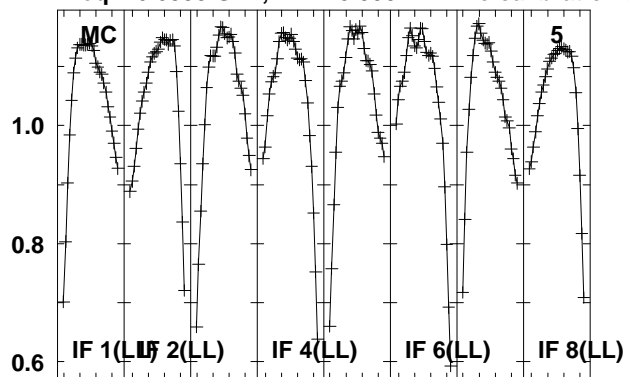

Lower frame: Real Jy
Total-power spectrum Antenna: *
Timerange: 00/14:55:22 to 00/14:56:50

Plot file version 207 created 15-MAR-2012 17:32:53
 2102-G85 EZ020E 2.UVDATA.1
 Freq = 6.6335 GHz, Bw = 8.000 MH No calibration applied and no bandpass applied

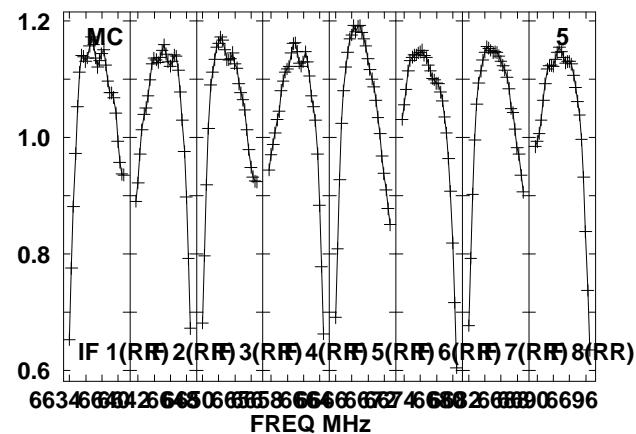
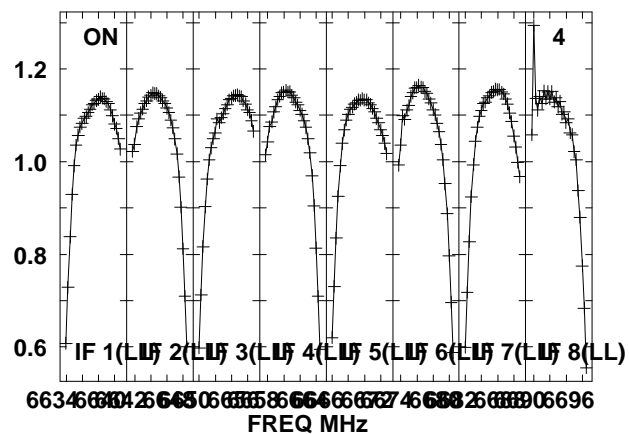
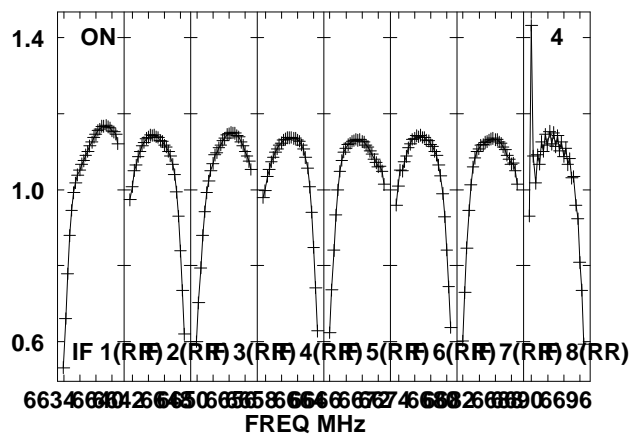
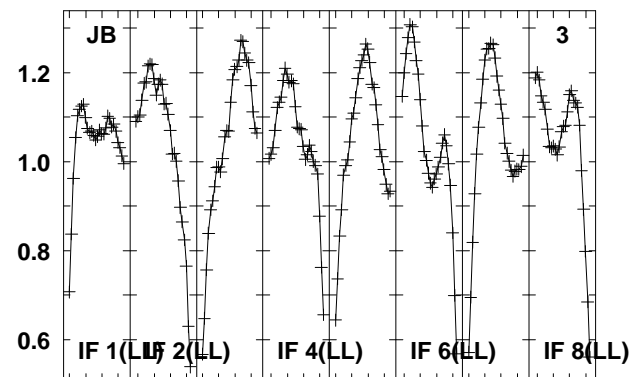
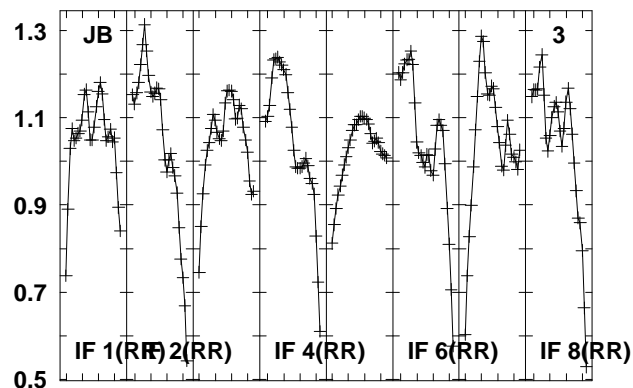
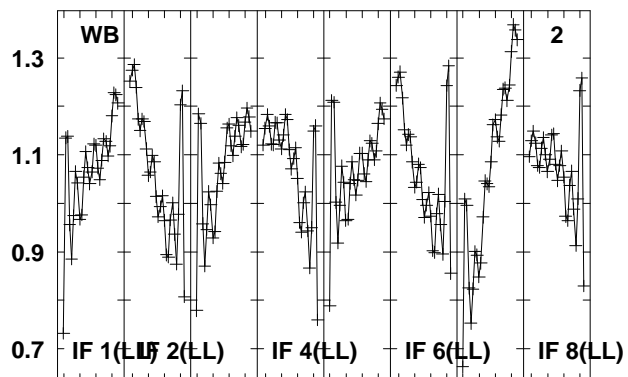
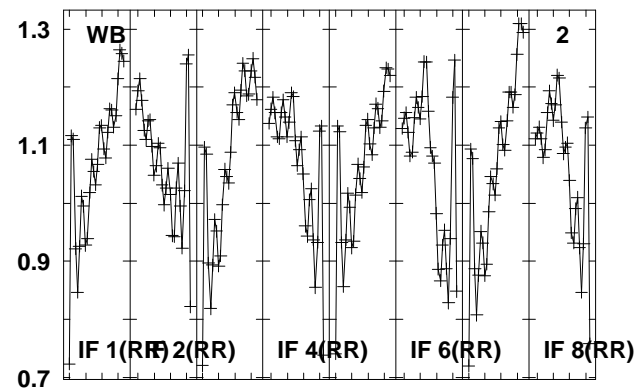
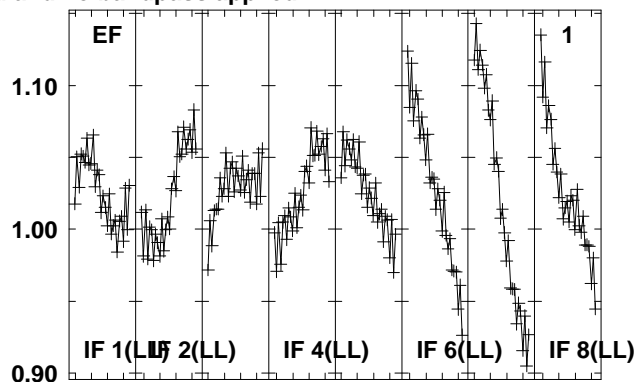
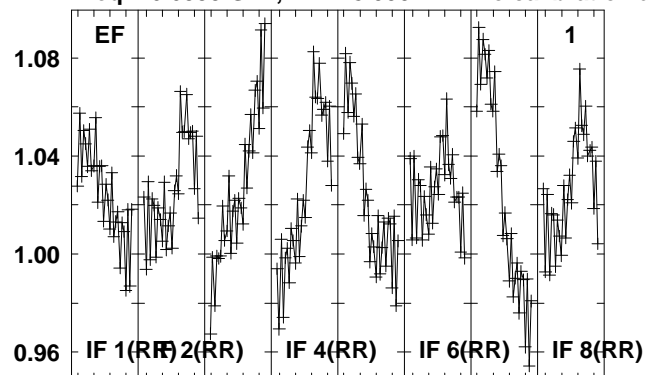

Lower frame: Real Jy
 Total-power spectrum Antenna: *
 Timerange: 00/14:56:52 to 00/14:58:20

Plot file version 208 created 15-MAR-2012 17:32:53

2102-G85 EZ020E 2.UVDATA.1

Freq = 6.6335 GHz, Bw = 8.000 MH No calibration applied and no bandpass applied

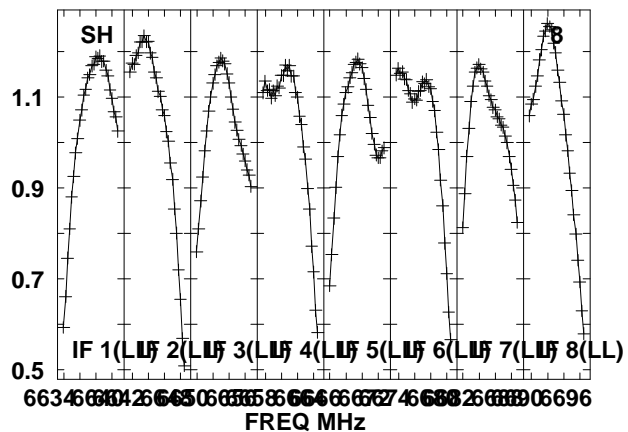
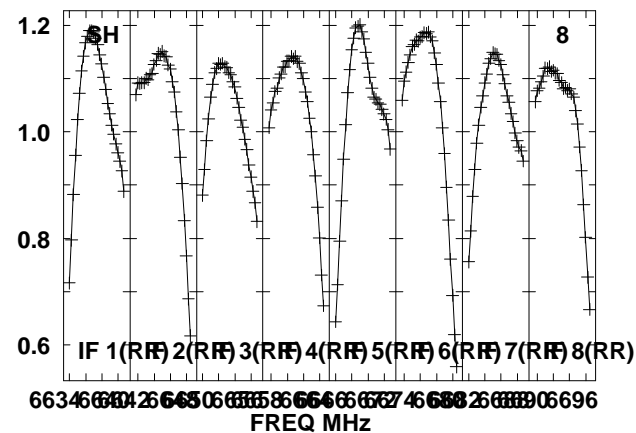
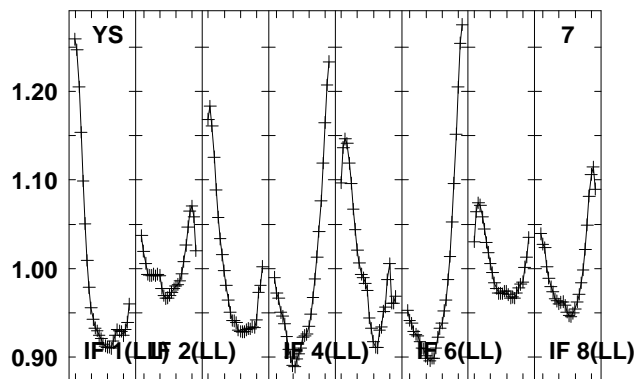
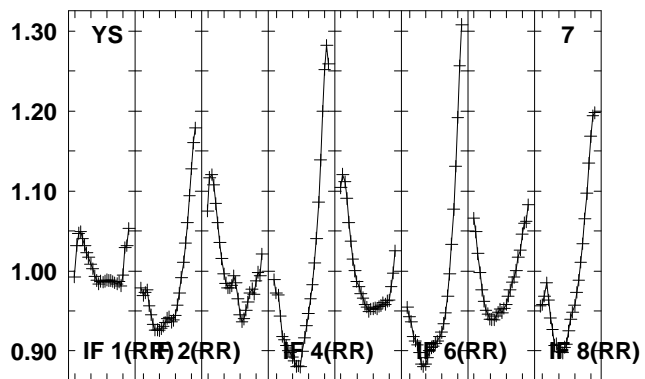
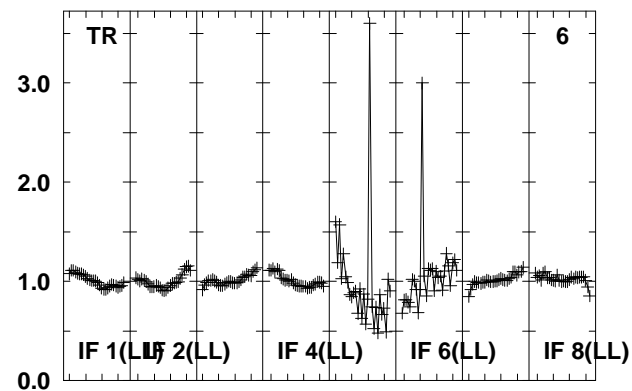
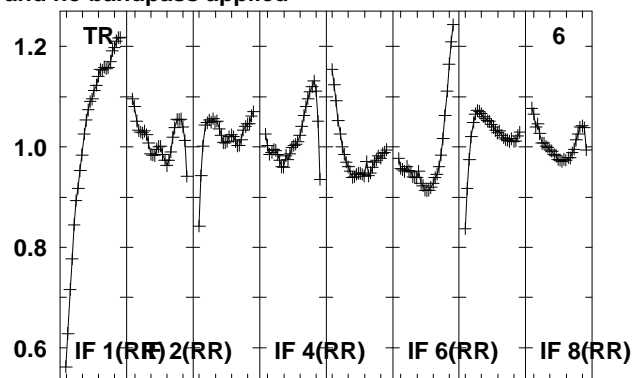
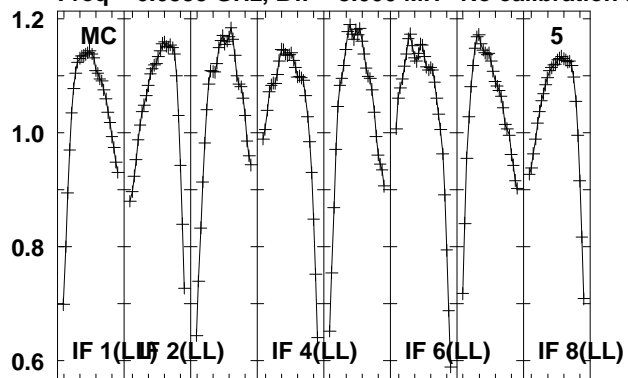

Lower frame: Real Jy
Total-power spectrum Antenna: *
Timerange: 00/14:56:52 to 00/14:58:20

Plot file version 209 created 15-MAR-2012 17:32:54

G85.40 EZ020E 2.UVDATA.1

Freq = 6.6335 GHz, Bw = 8.000 MH No calibration applied and no bandpass applied

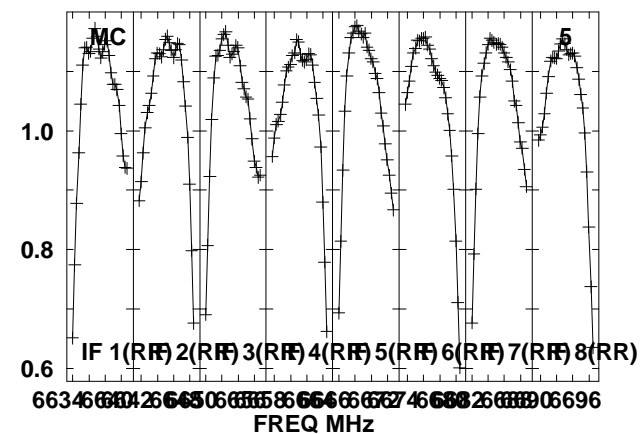
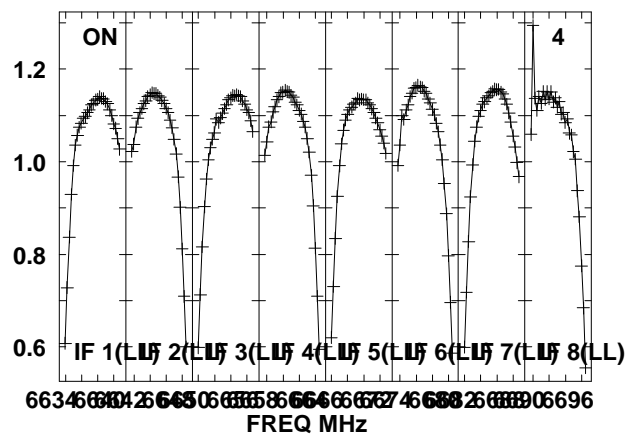
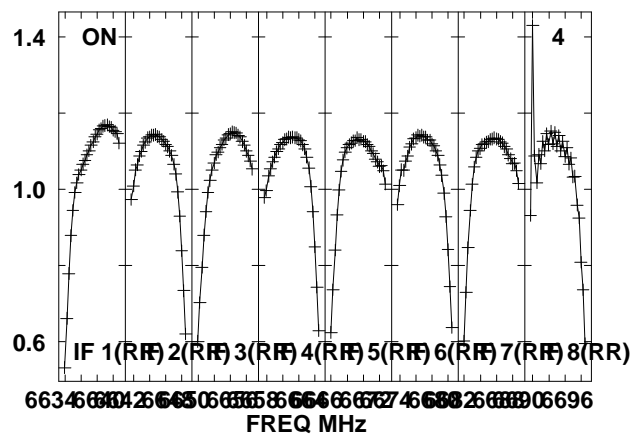
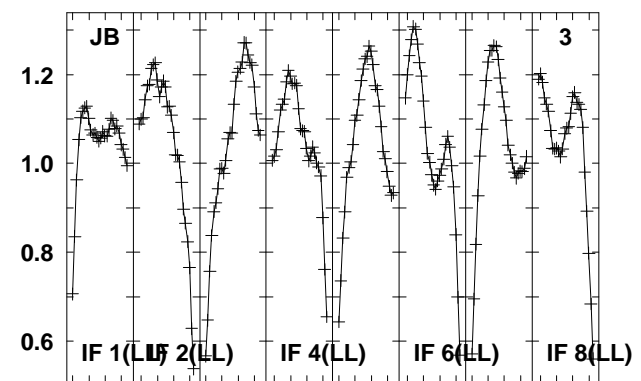
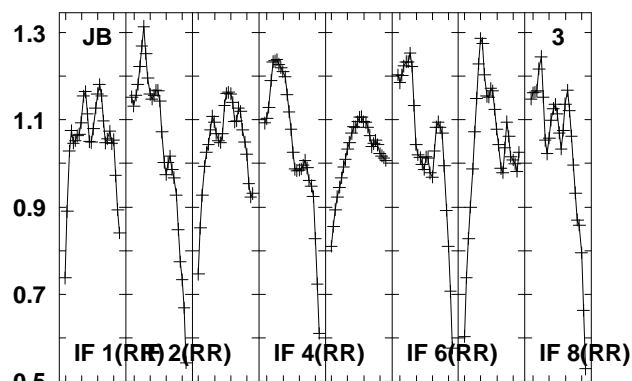
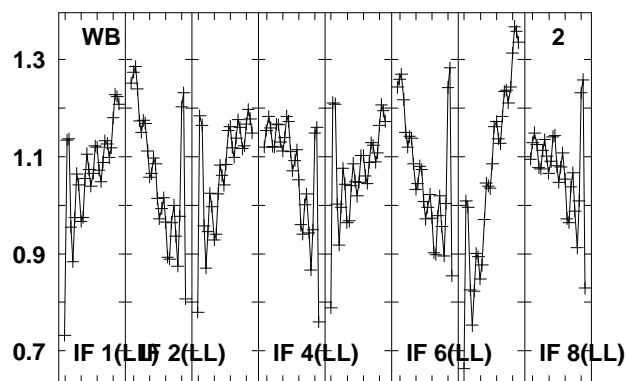
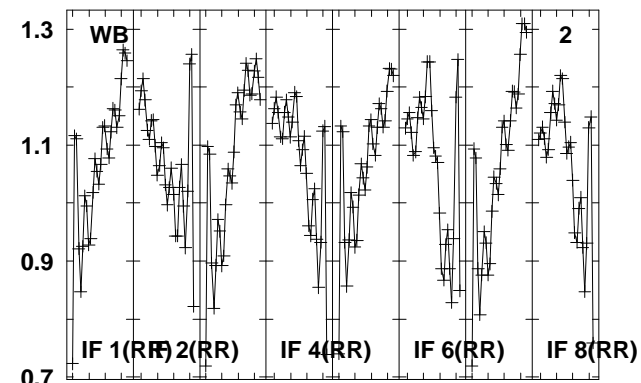
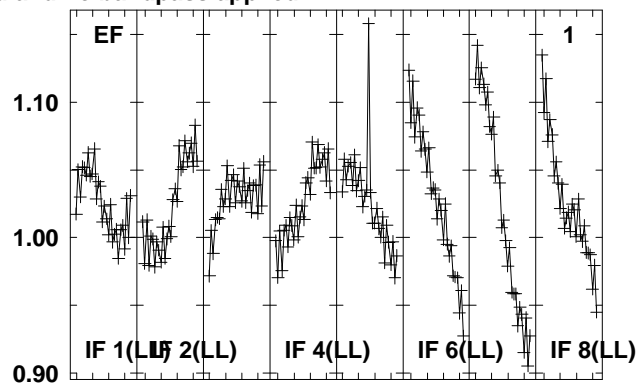
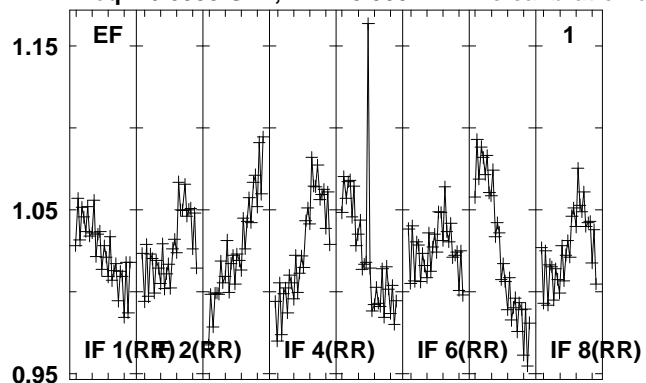

Lower frame: Real Jy
Total-power spectrum Antenna: *
Timerange: 00/14:58:21 to 00/14:59:49

Plot file version 210 created 15-MAR-2012 17:32:55

G85.40 EZ020E 2.UVDATA.1

Freq = 6.6335 GHz, Bw = 8.000 MH No calibration applied and no bandpass applied

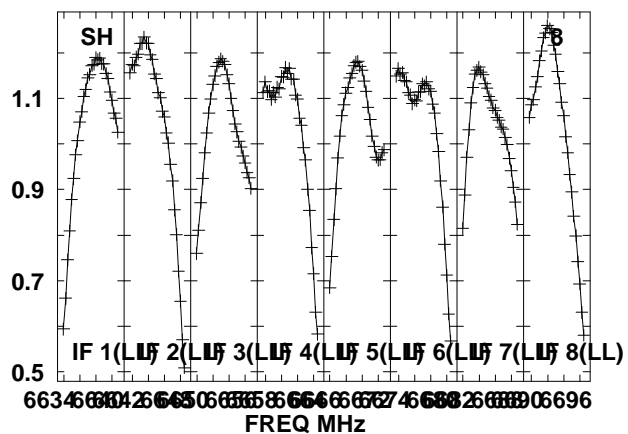
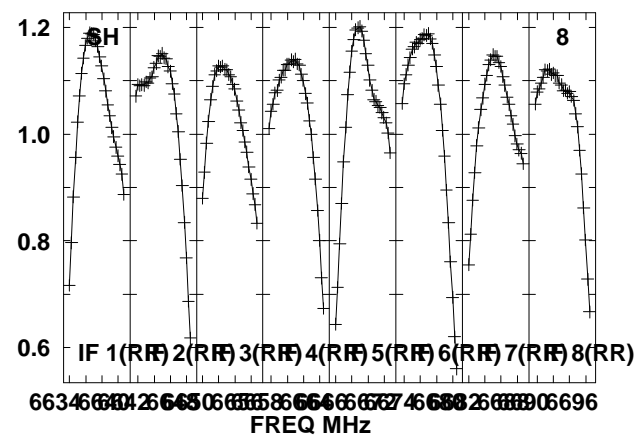
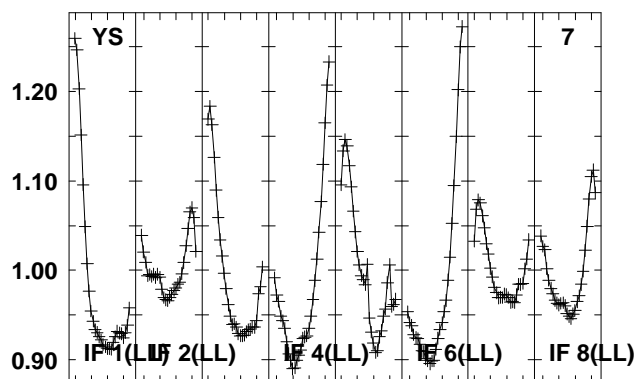
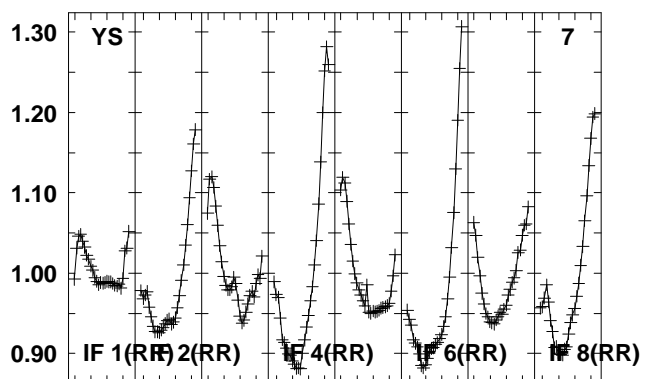
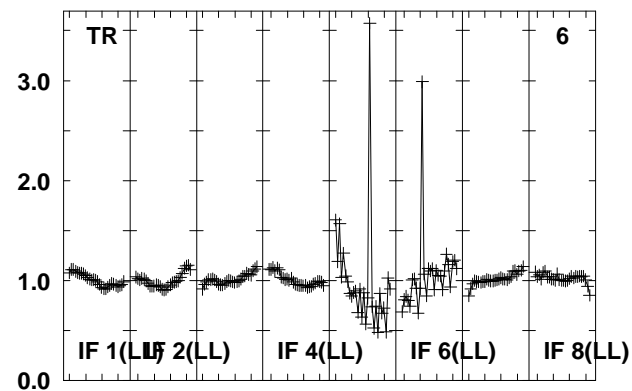
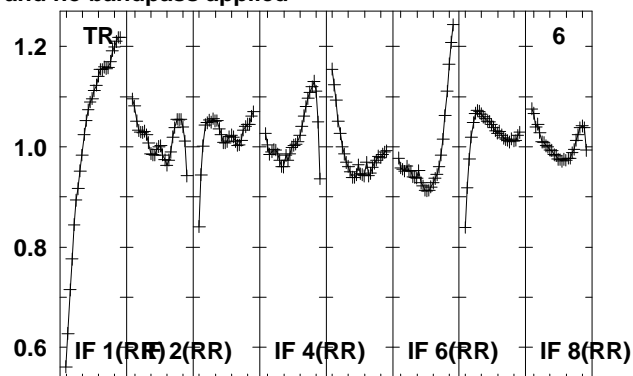
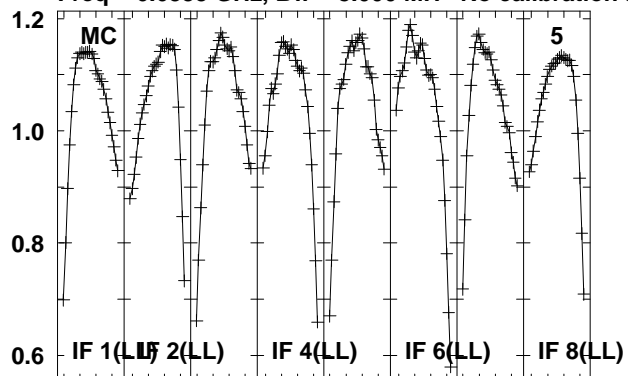

Lower frame: Real Jy

Total-power spectrum Antenna: *

Timerange: 00/14:58:21 to 00/14:59:49

Plot file version 211 created 15-MAR-2012 17:32:56

2114-G85 EZ020E 2.UVDATA.1

Freq = 6.6335 GHz, Bw = 8.000 MH No calibration applied and no bandpass applied

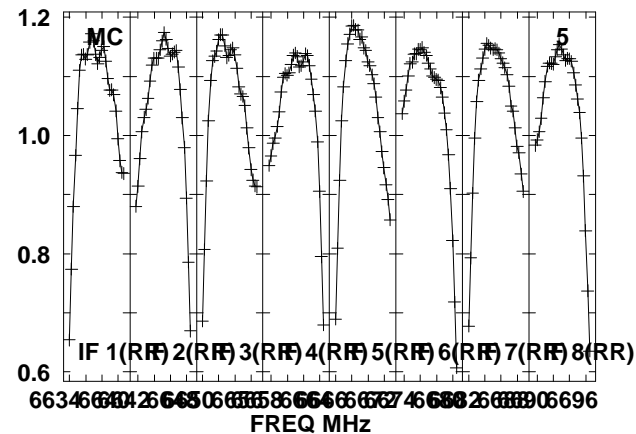
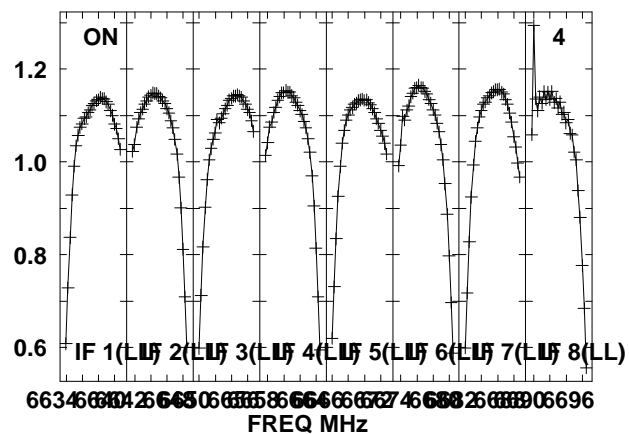
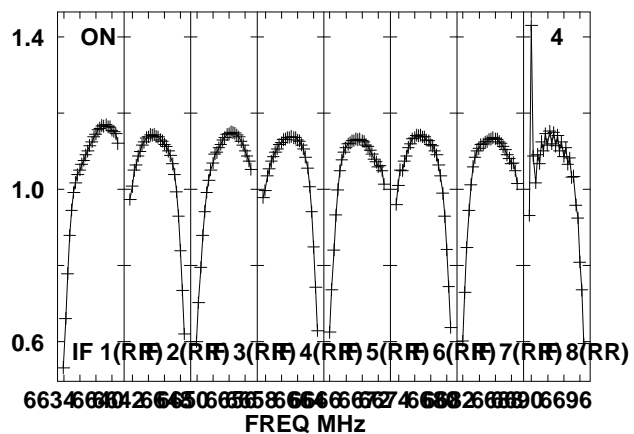
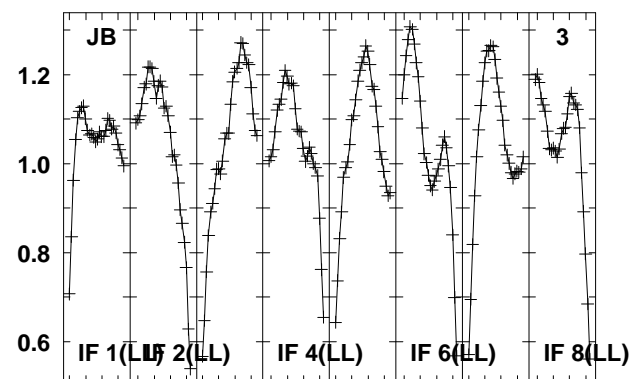
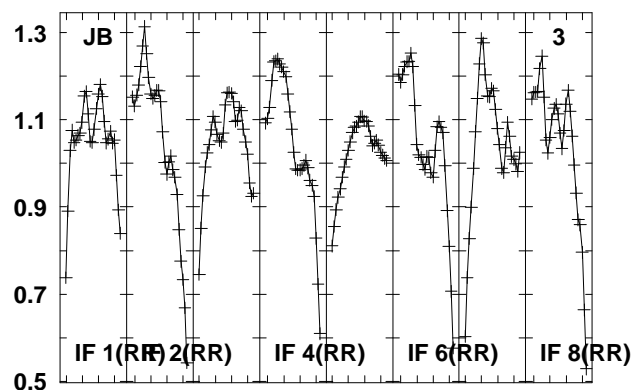
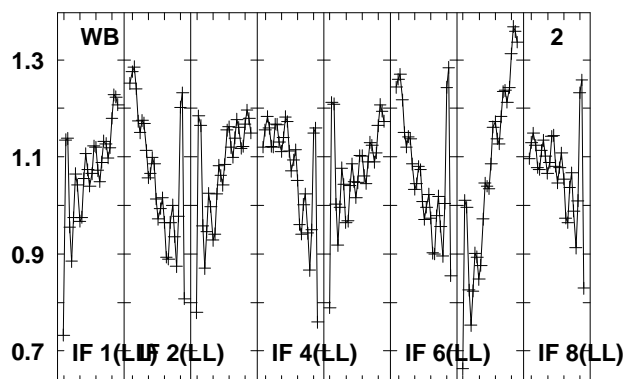
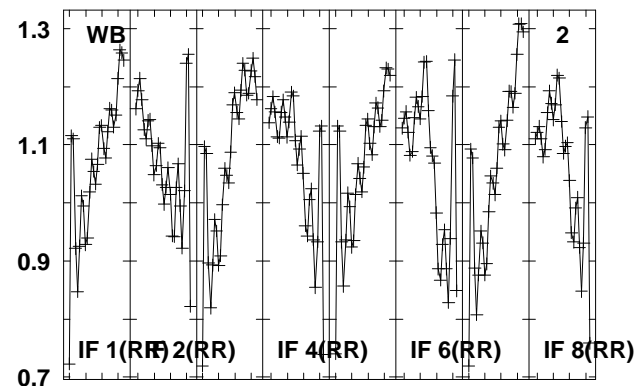
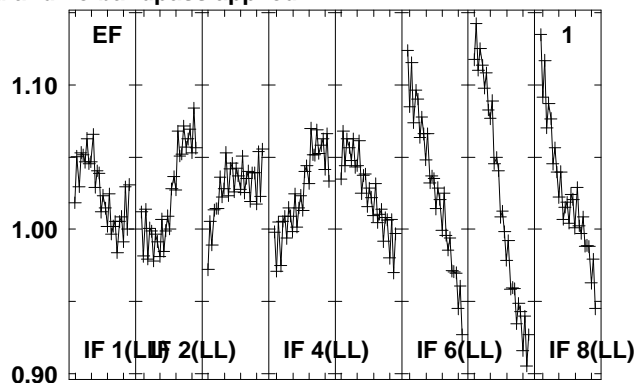
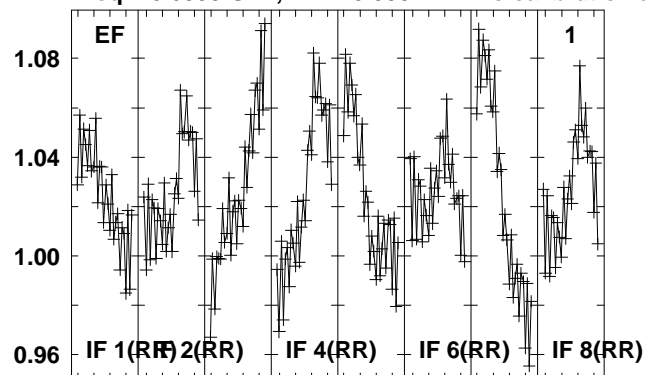

Lower frame: Real Jy
Total-power spectrum Antenna: *
Timerange: 00/14:59:51 to 00/15:01:19

Plot file version 212 created 15-MAR-2012 17:32:56

2114-G85 EZ020E 2.UVDATA.1

Freq = 6.6335 GHz, Bw = 8.000 MH No calibration applied and no bandpass applied

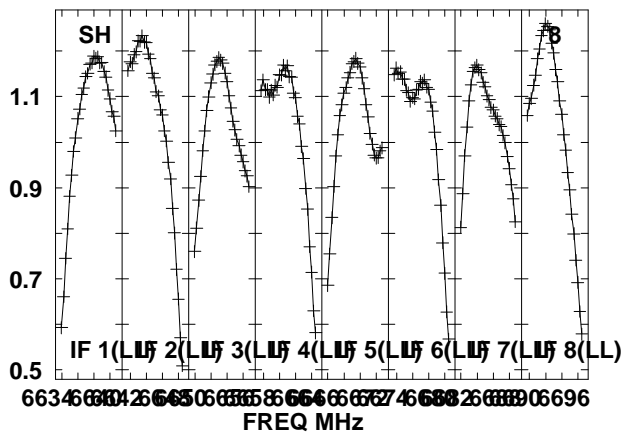
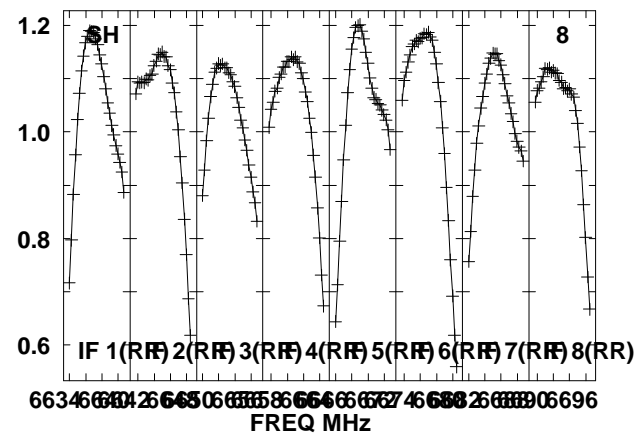
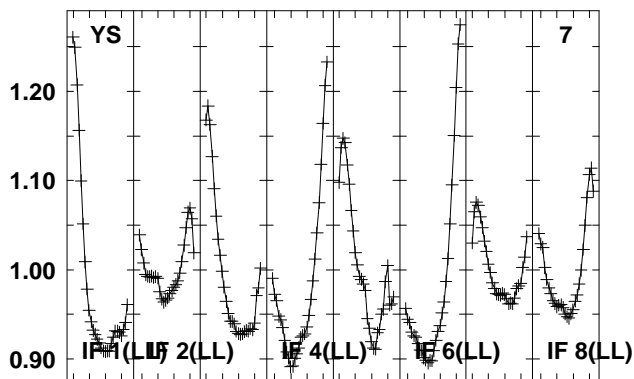
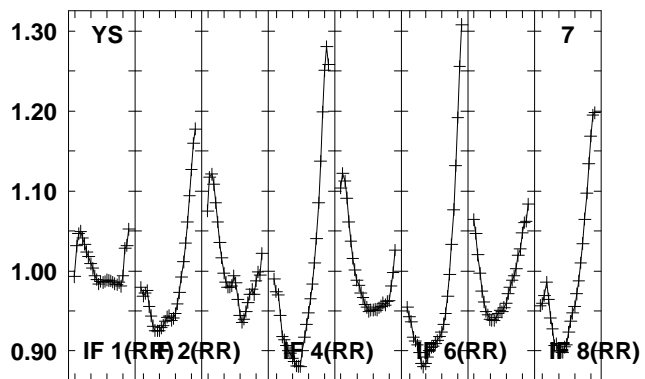
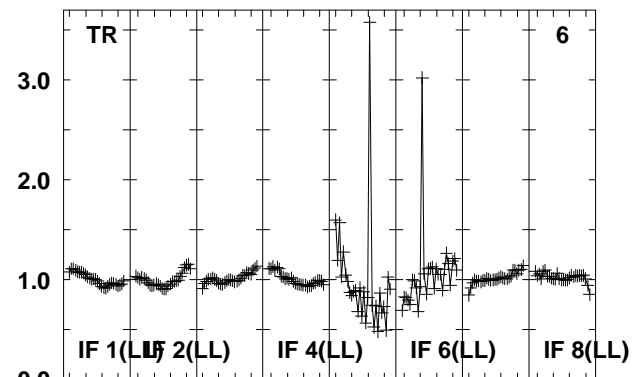
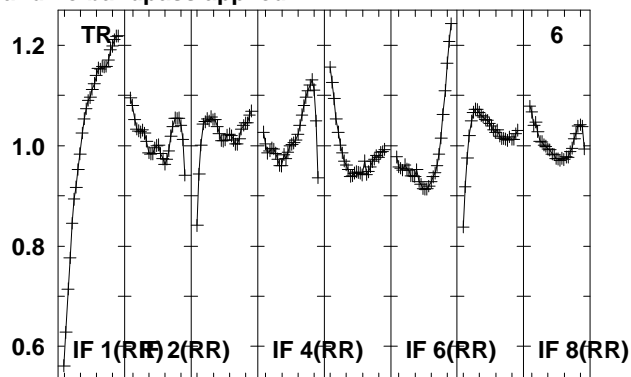
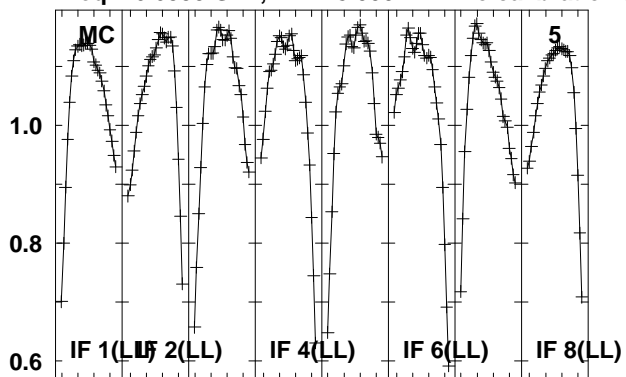

Lower frame: Real Jy

Total-power spectrum Antenna: *

Timerange: 00/14:59:51 to 00/15:01:19

Plot file version 213 created 15-MAR-2012 17:32:57

G85.40 EZ020E 2.UVDATA.1

Freq = 6.6335 GHz, Bw = 8.000 MH No calibration applied and no bandpass applied

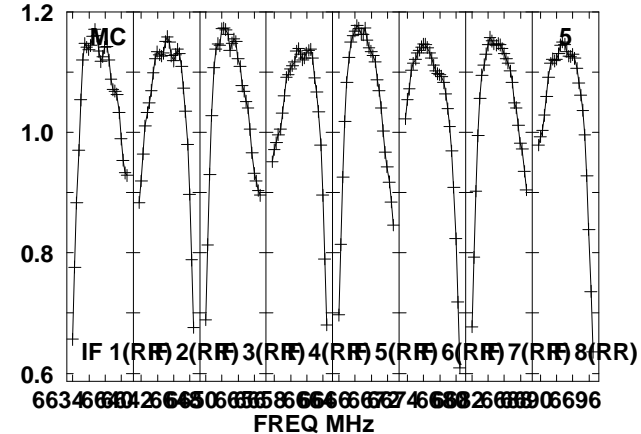
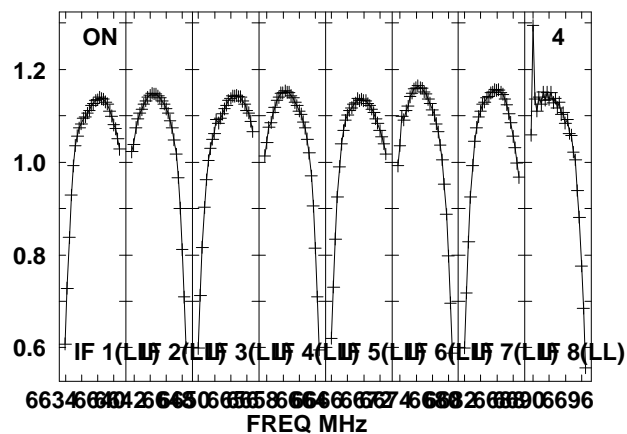
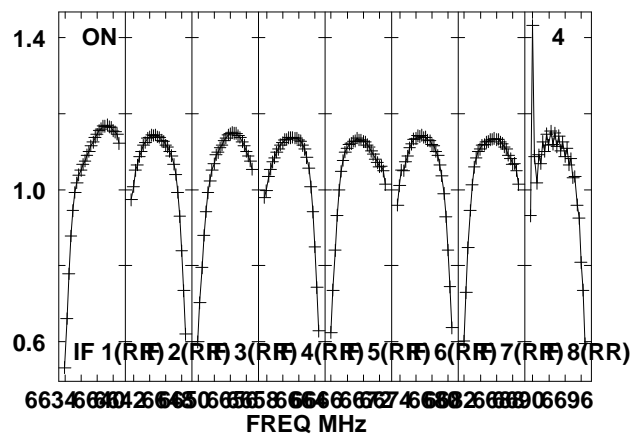
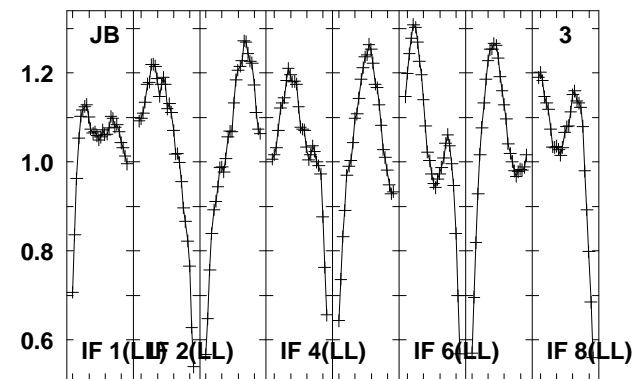
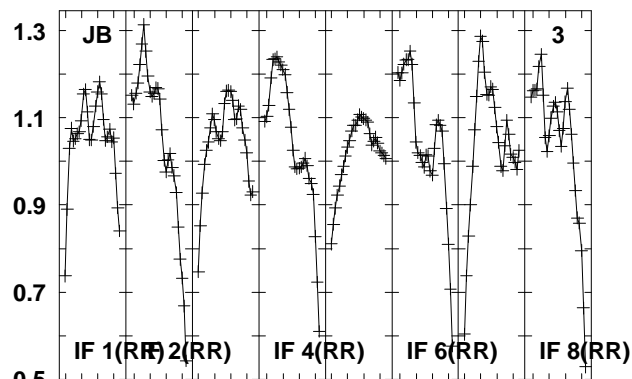
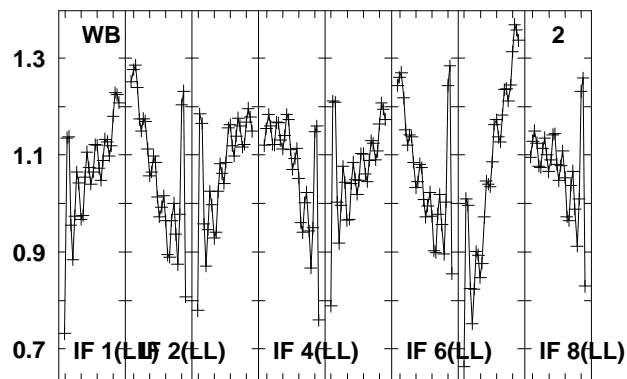
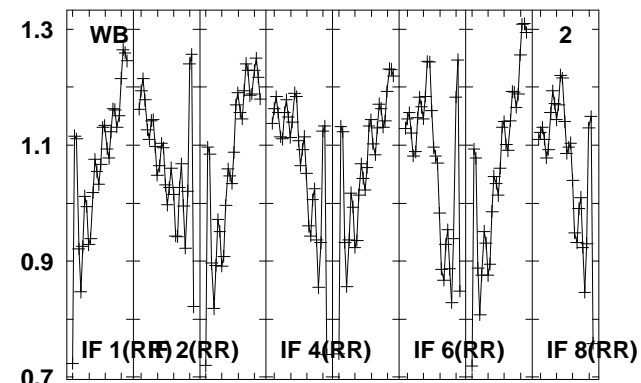
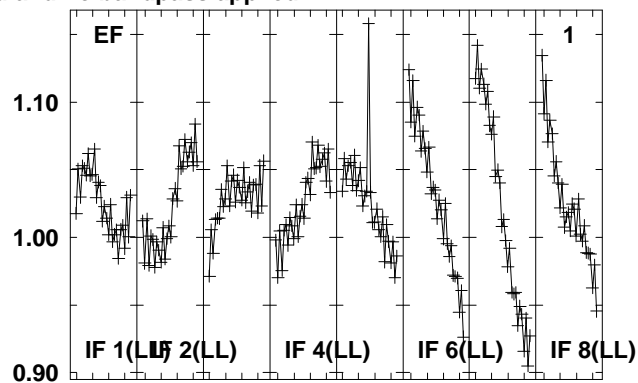
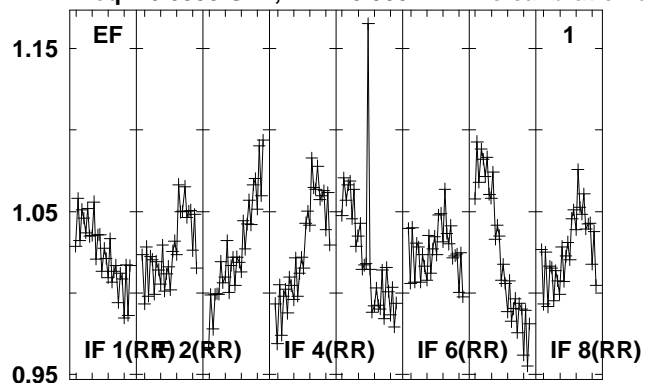

Lower frame: Real Jy
Total-power spectrum Antenna: *
Timerange: 00/15:02:06 to 00/15:03:03

Plot file version 214 created 15-MAR-2012 17:32:57

G85.40 EZ020E 2.UVDATA.1

Freq = 6.6335 GHz, Bw = 8.000 MH No calibration applied and no bandpass applied

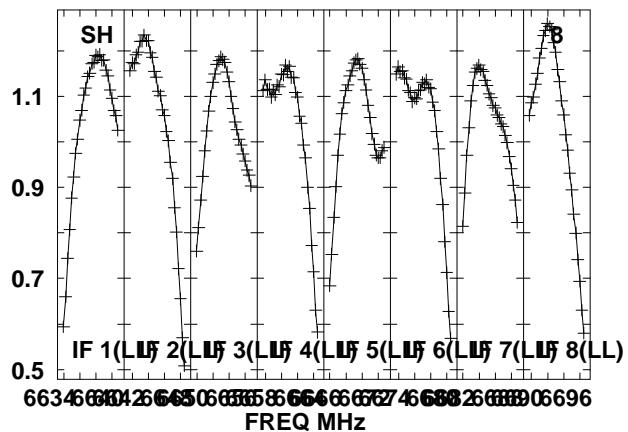
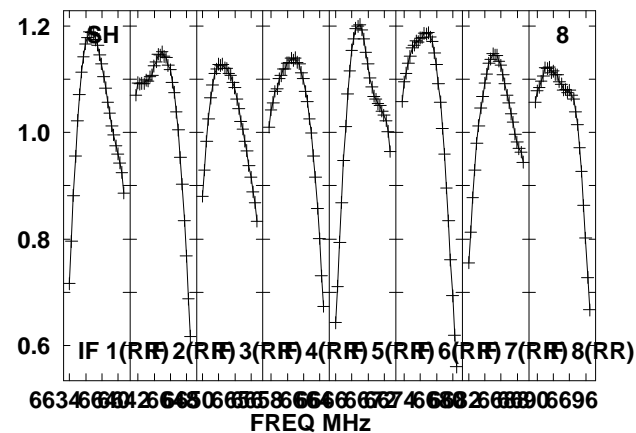
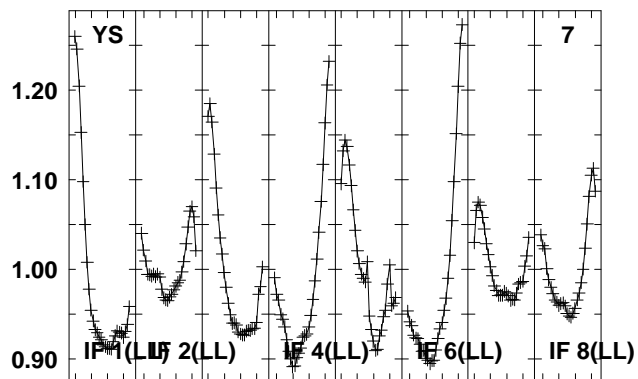
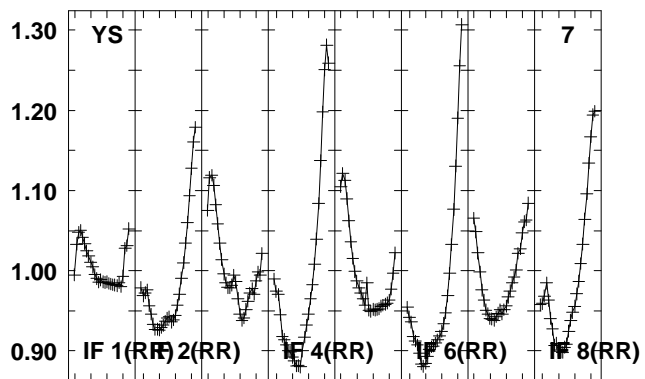
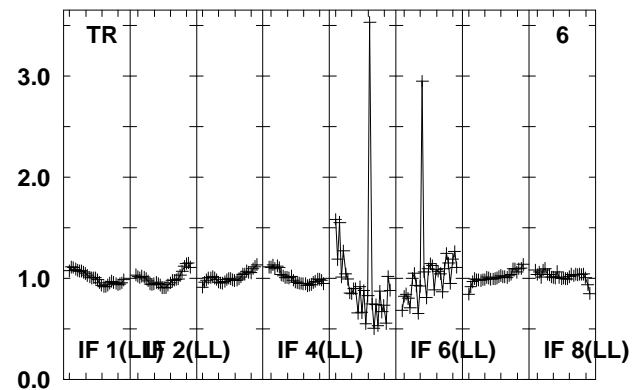
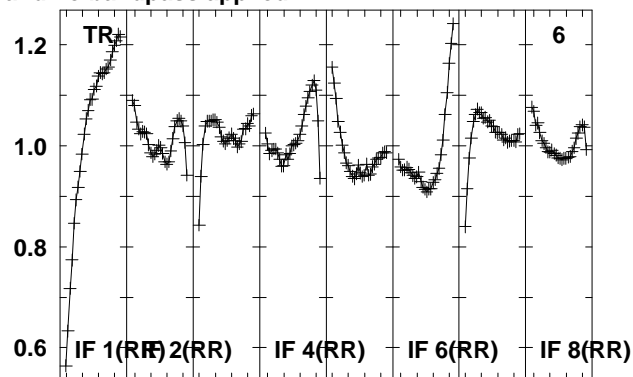
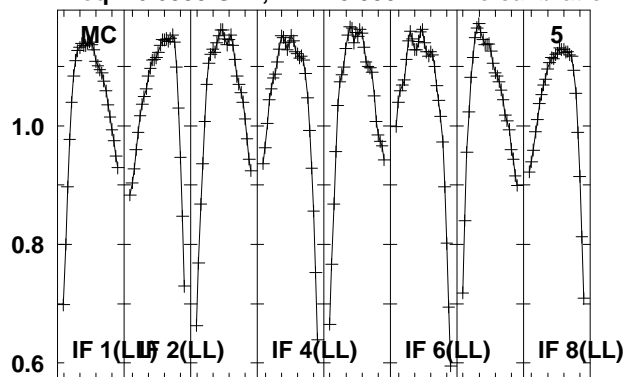

Lower frame: Real Jy
Total-power spectrum Antenna: *
Timerange: 00/15:02:06 to 00/15:03:03

Plot file version 215 created 15-MAR-2012 17:32:59

G85.40 EZ020E 2.UVDATA.1

Freq = 6.6335 GHz, Bw = 8.000 MH No calibration applied and no bandpass applied

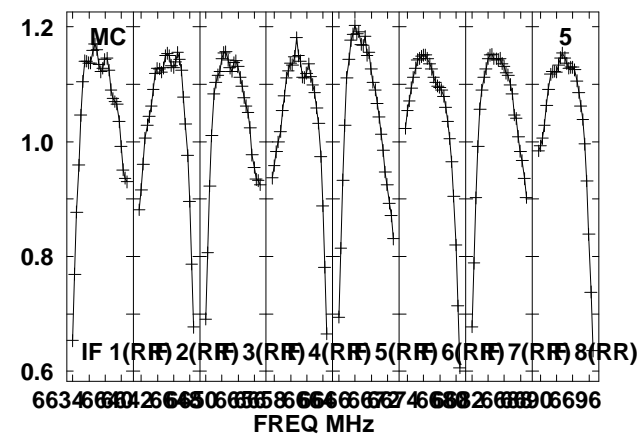
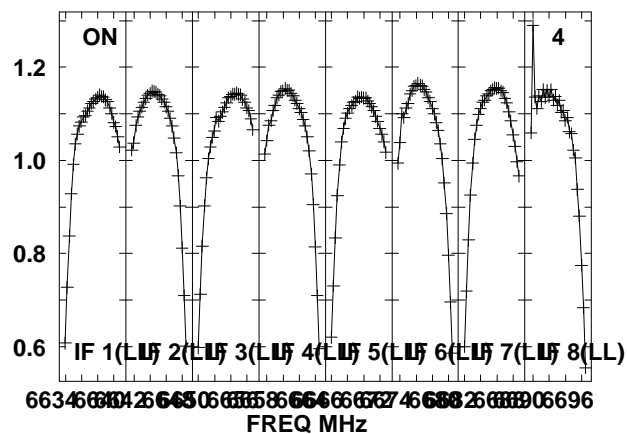
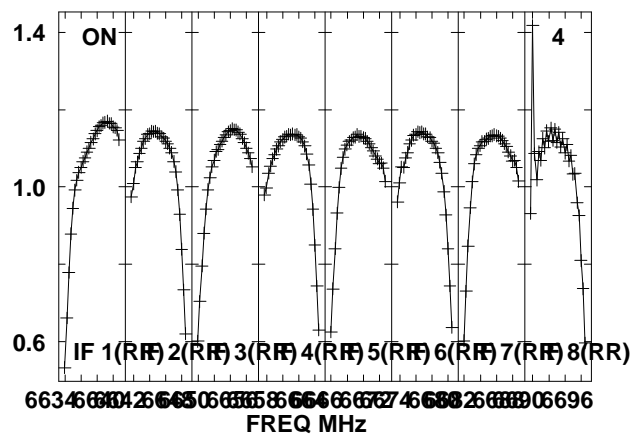
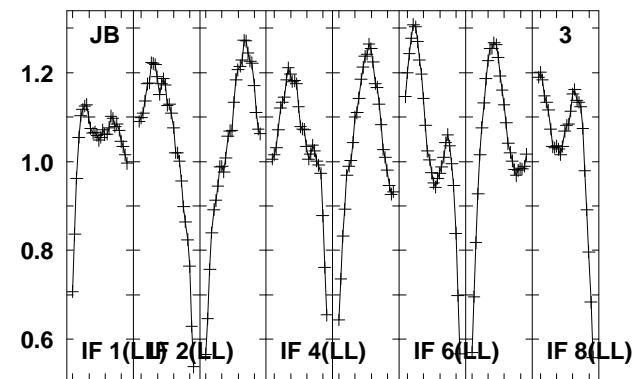
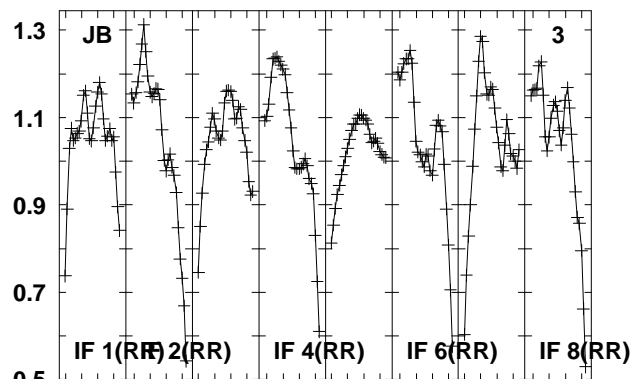
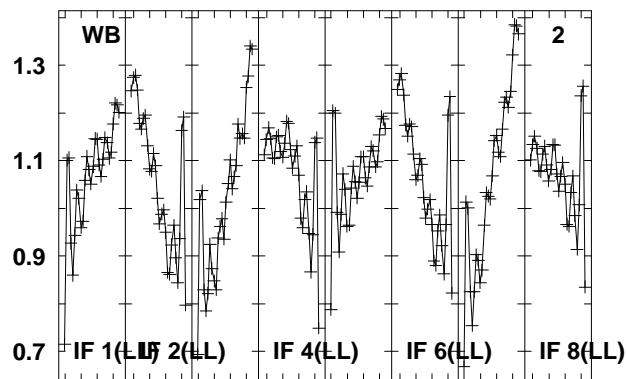
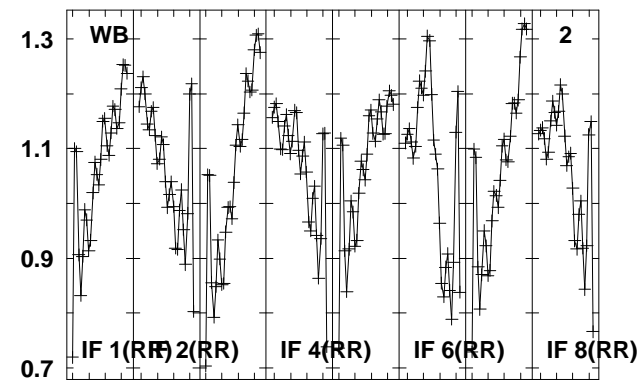
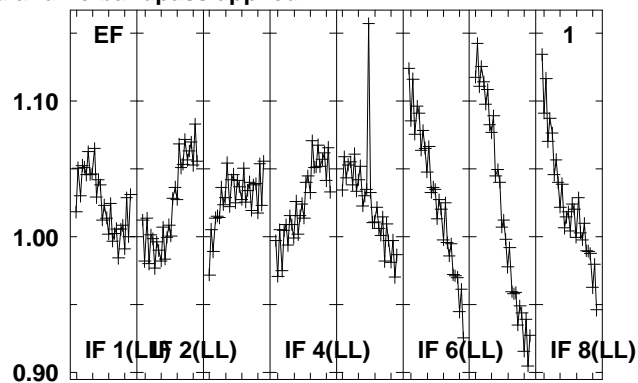
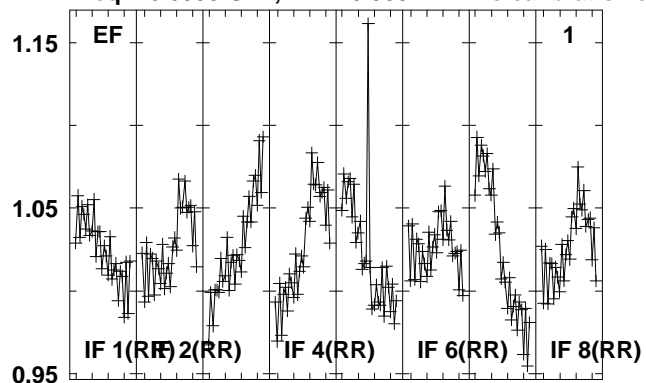

Lower frame: Real Jy
Total-power spectrum Antenna: *
Timerange: 00/15:36:25 to 00/15:37:22

Plot file version 216 created 15-MAR-2012 17:32:59

G85.40 EZ020E 2.UVDATA.1

Freq = 6.6335 GHz, Bw = 8.000 MH No calibration applied and no bandpass applied

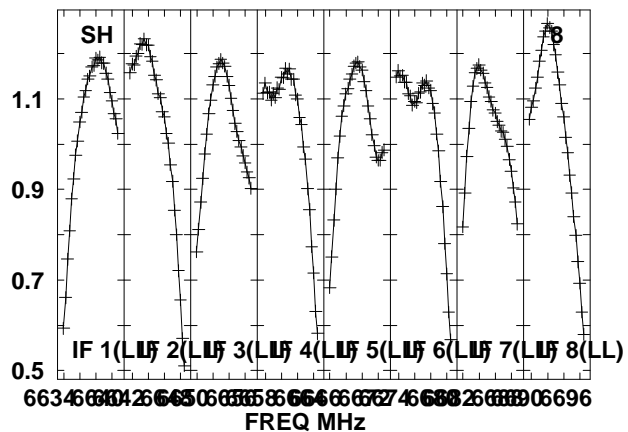
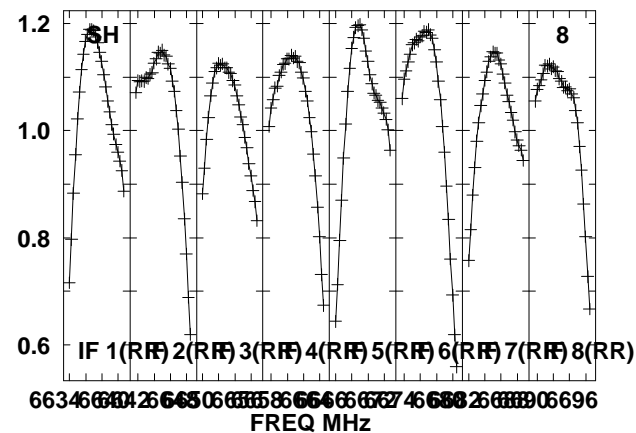
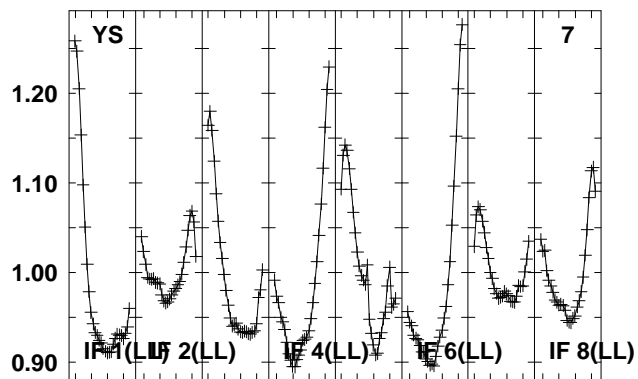
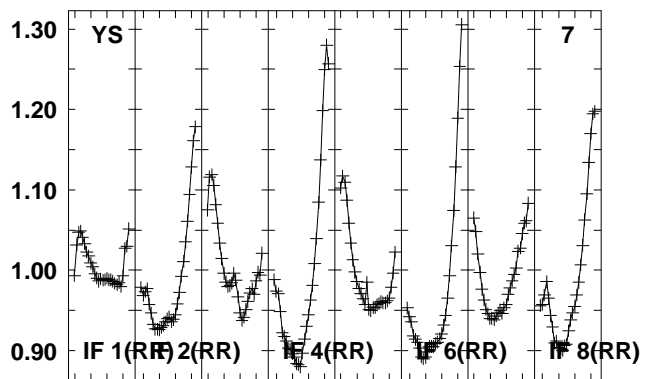
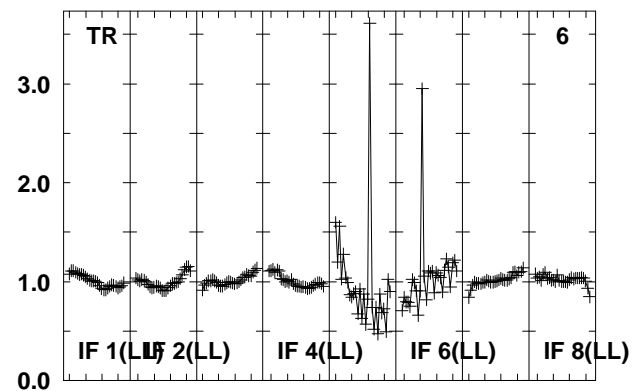
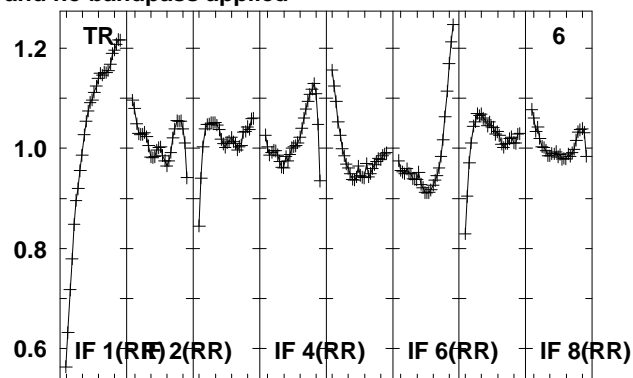
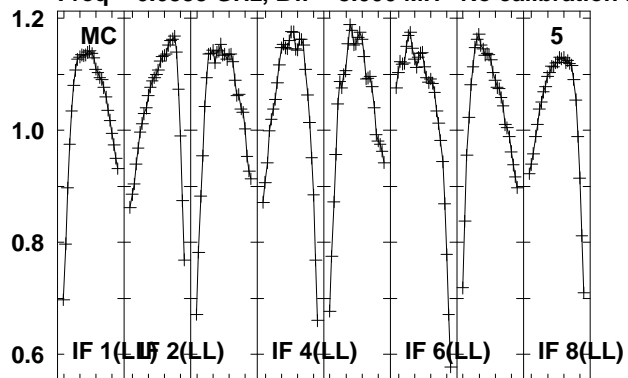

Lower frame: Real Jy

Total-power spectrum Antenna: *

Timerange: 00/15:36:25 to 00/15:37:22

Plot file version 217 created 15-MAR-2012 17:33:00

2102-G85 EZ020E 2.UVDATA.1

Freq = 6.6335 GHz, Bw = 8.000 MH No calibration applied and no bandpass applied

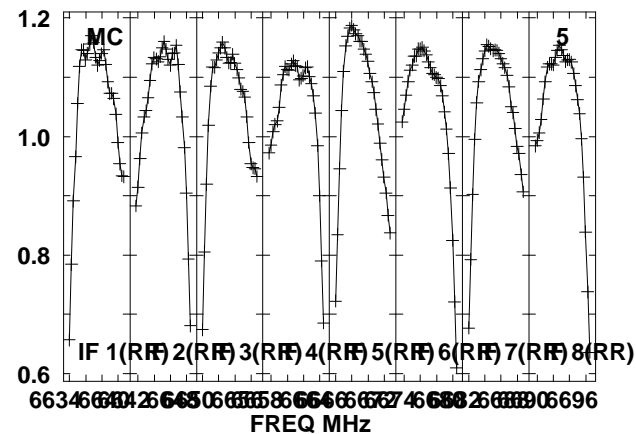
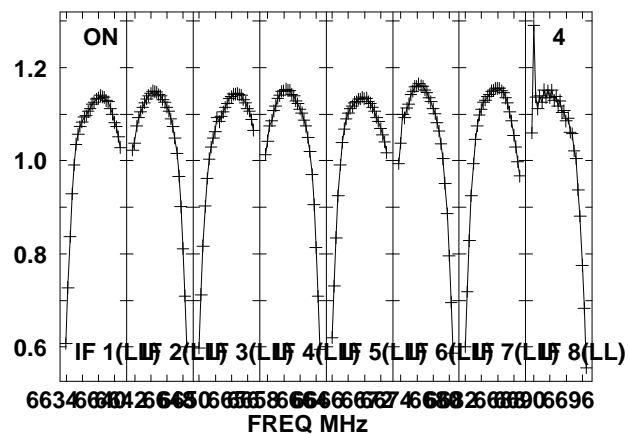
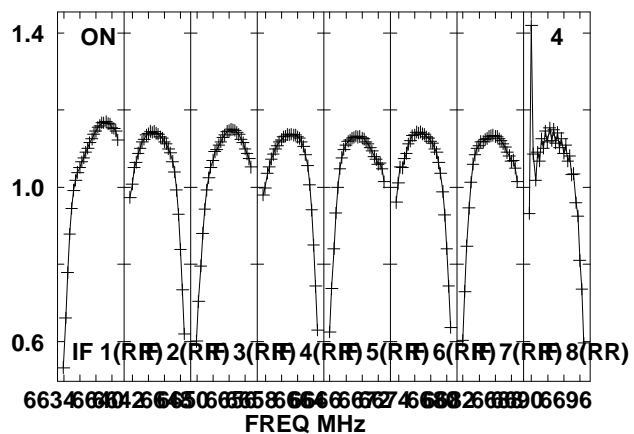
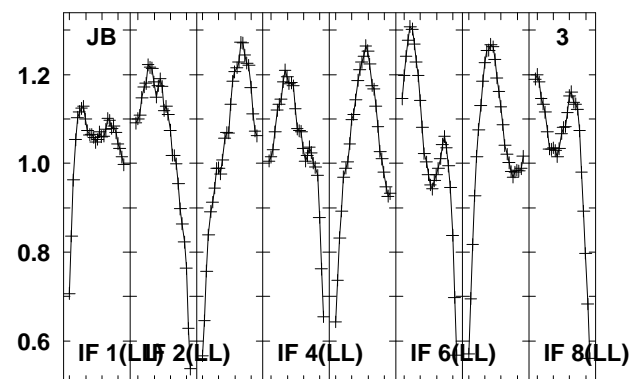
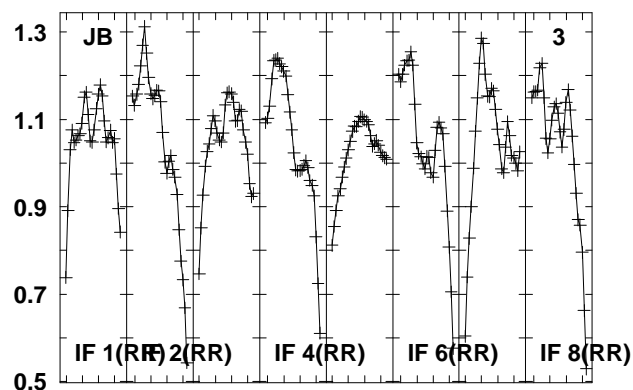
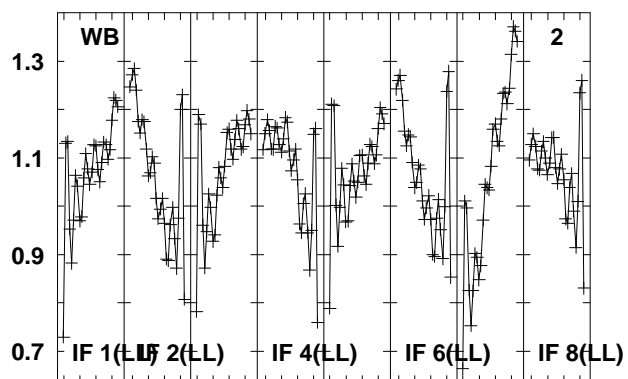
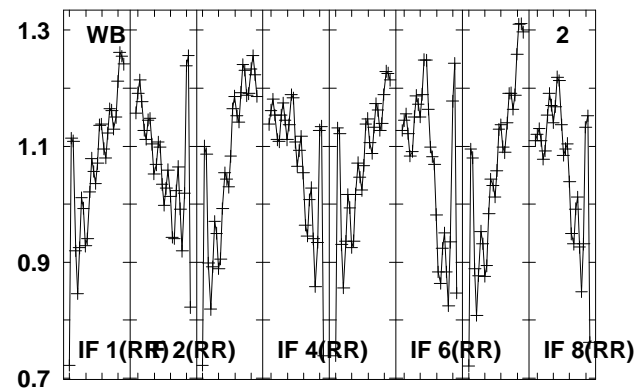
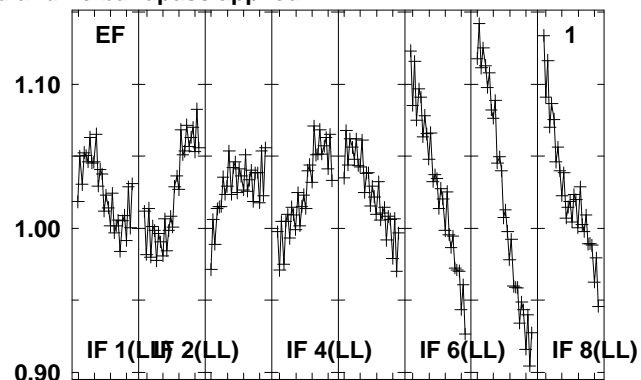
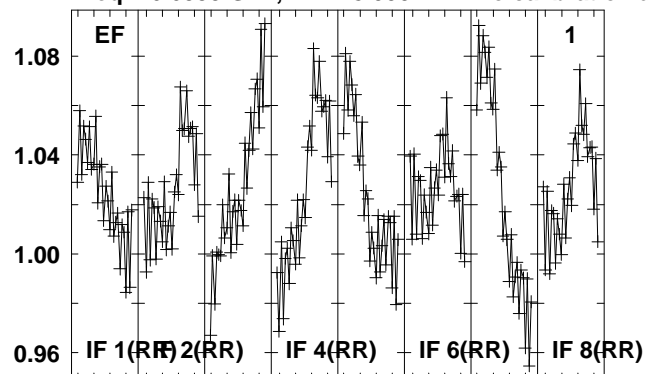

Lower frame: Real Jy

Total-power spectrum Antenna: *

Timerange: 00/15:37:25 to 00/15:38:53

Plot file version 218 created 15-MAR-2012 17:33:01

2102-G85 EZ020E 2.UVDATA.1

Freq = 6.6335 GHz, Bw = 8.000 MH No calibration applied and no bandpass applied

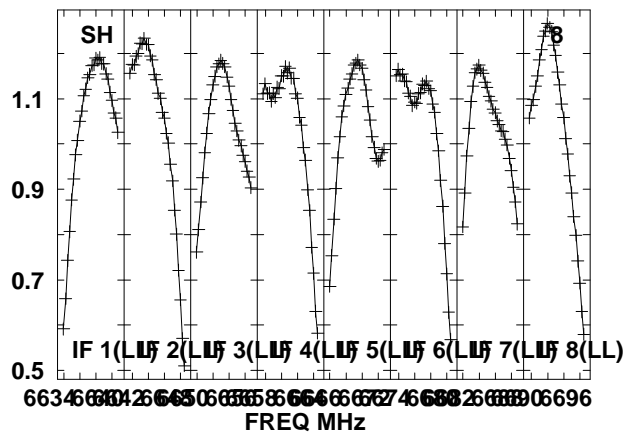
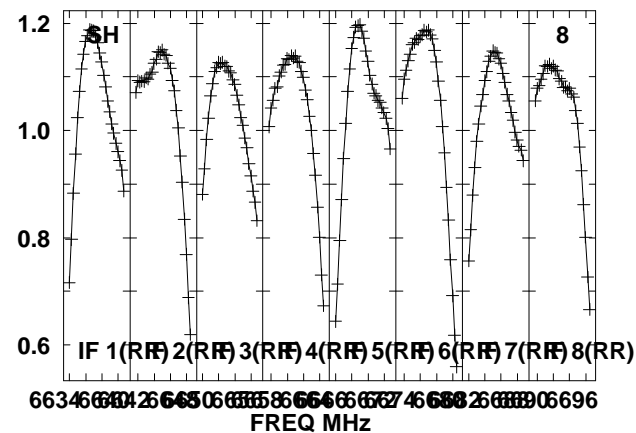
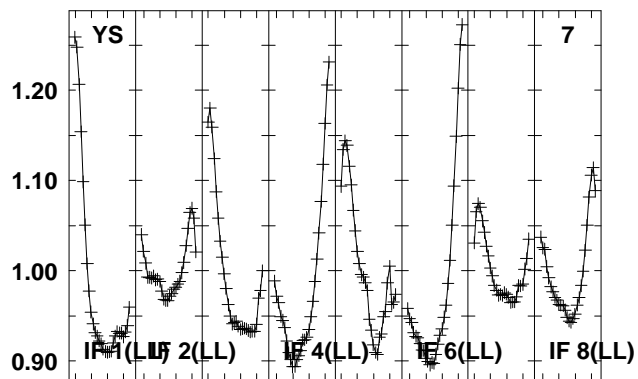
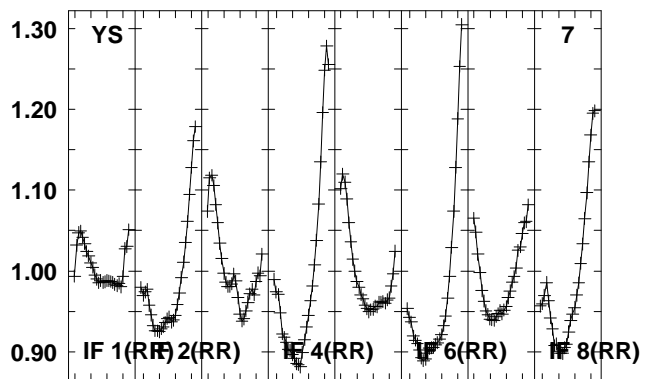
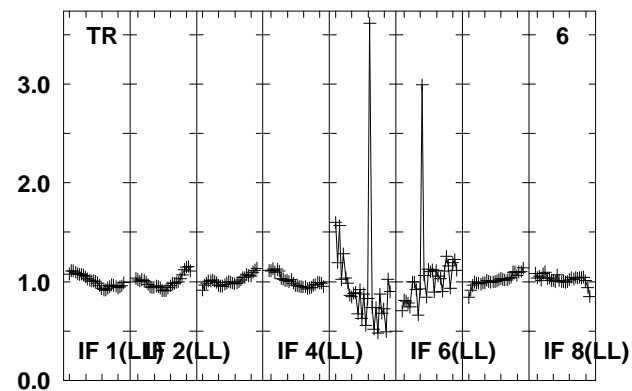
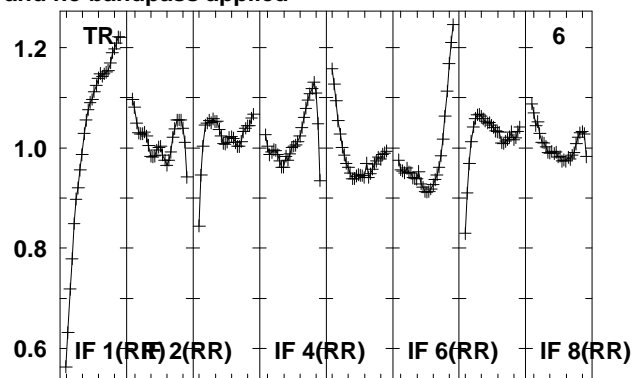
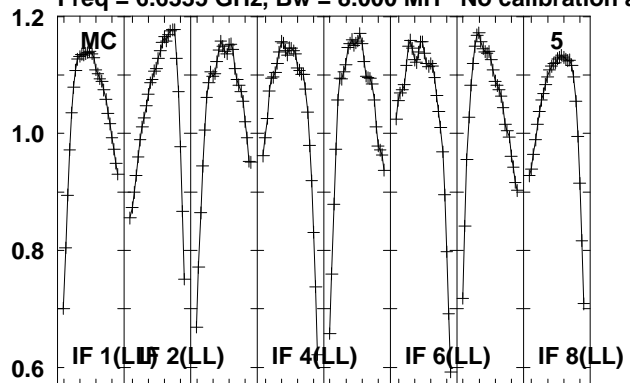

Lower frame: Real Jy

Total-power spectrum Antenna: *

Timerange: 00/15:37:25 to 00/15:38:53

Plot file version 219 created 15-MAR-2012 17:33:02

G85.40 EZ020E 2.UVDATA.1

Freq = 6.6335 GHz, Bw = 8.000 MH No calibration applied and no bandpass applied

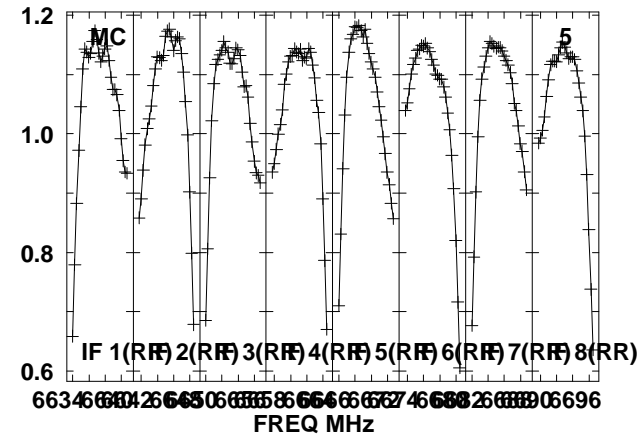
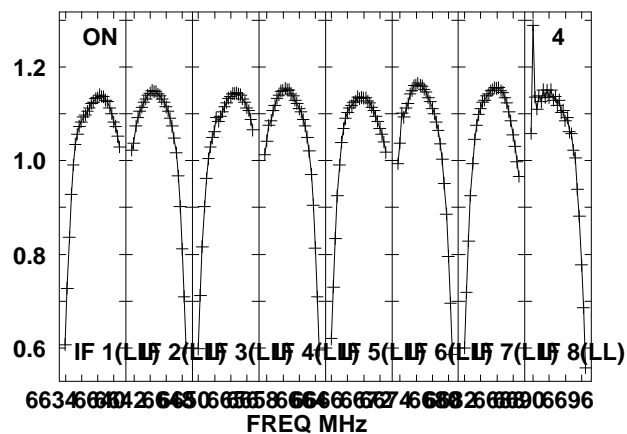
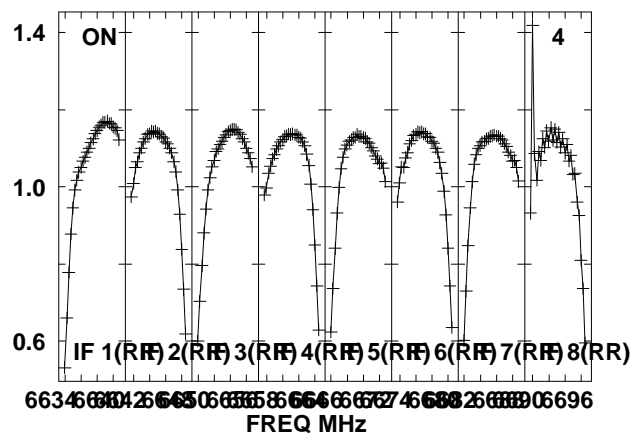
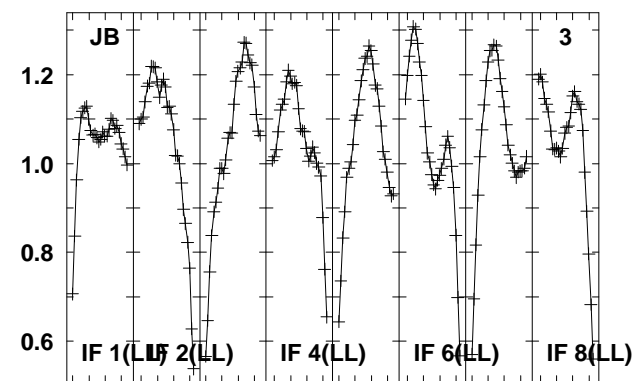
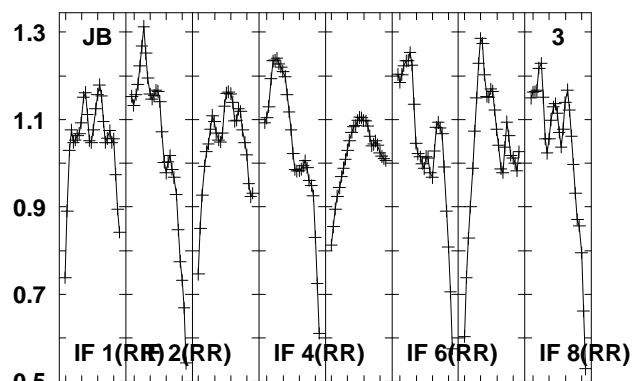
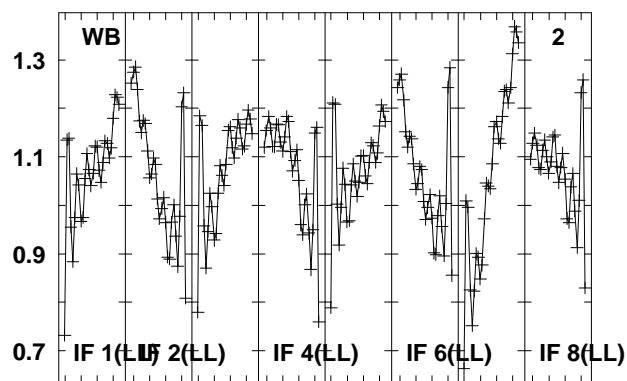
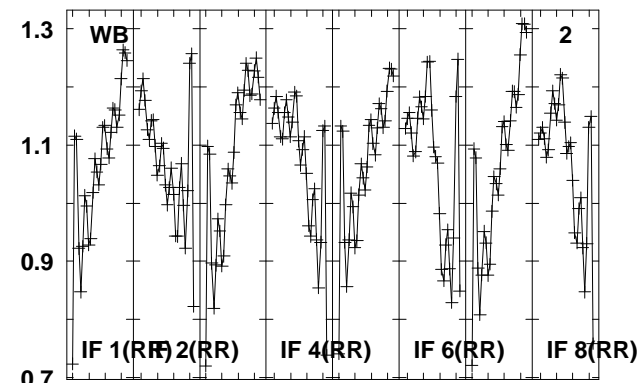
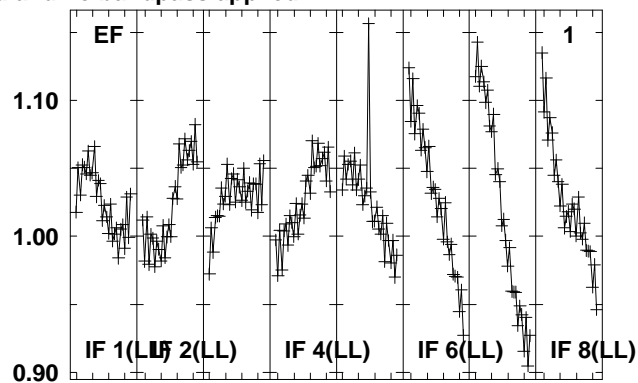
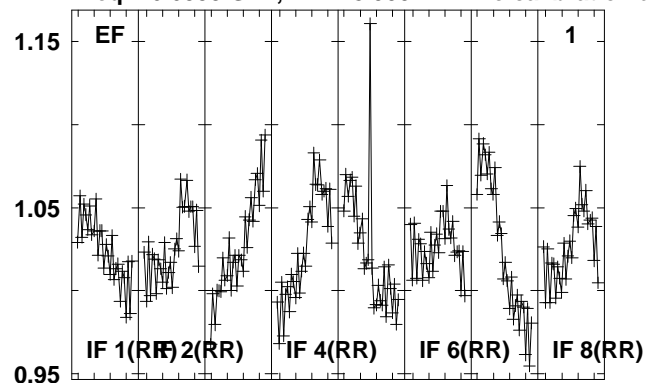

Lower frame: Real Jy
Total-power spectrum Antenna: *
Timerange: 00/15:38:55 to 00/15:40:23

Plot file version 220 created 15-MAR-2012 17:33:03

G85.40 EZ020E 2.UVDATA.1

Freq = 6.6335 GHz, Bw = 8.000 MH No calibration applied and no bandpass applied

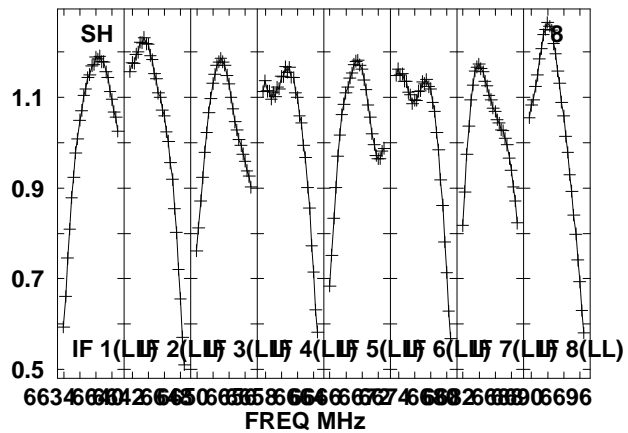
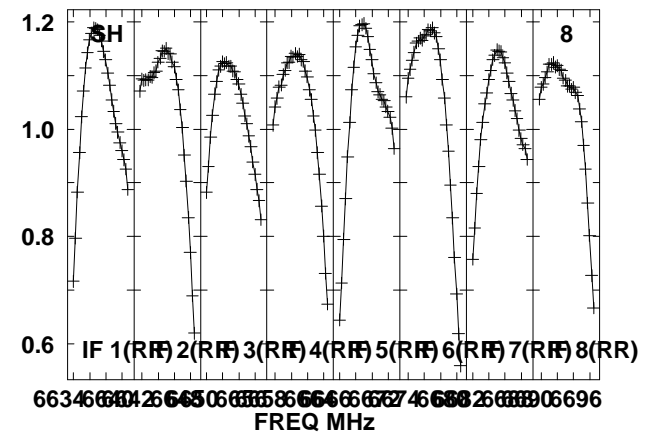
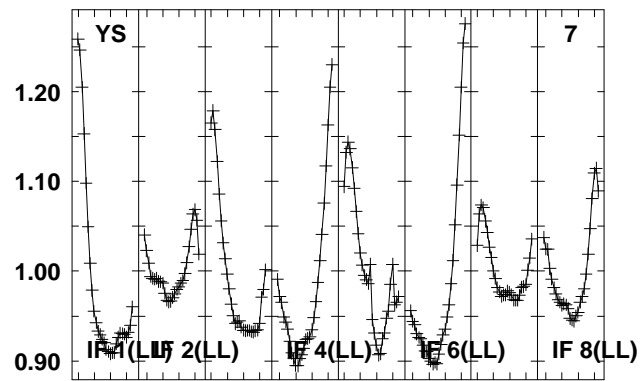
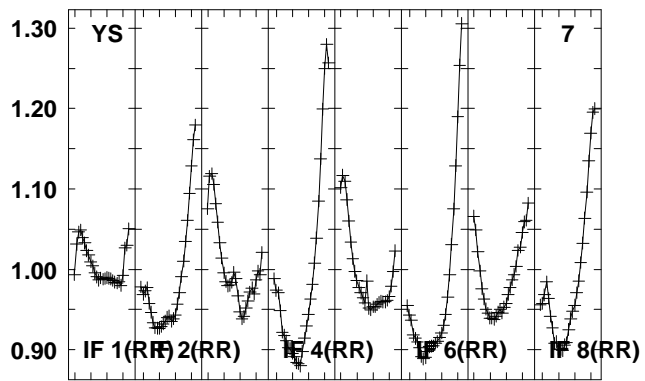
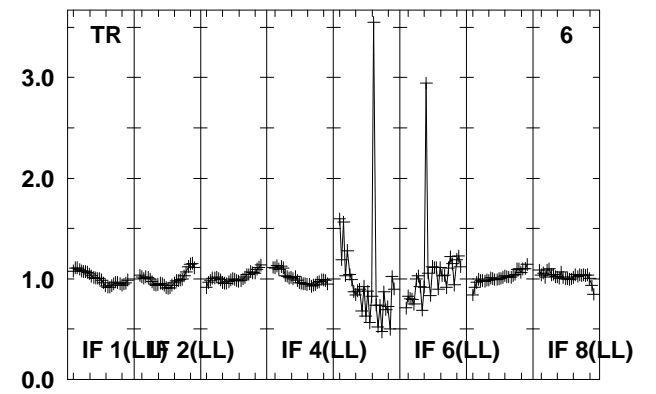
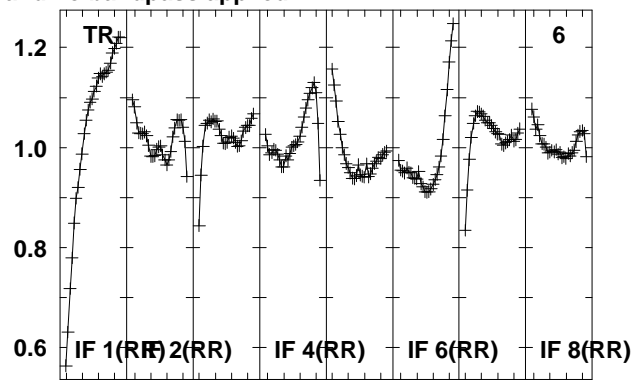
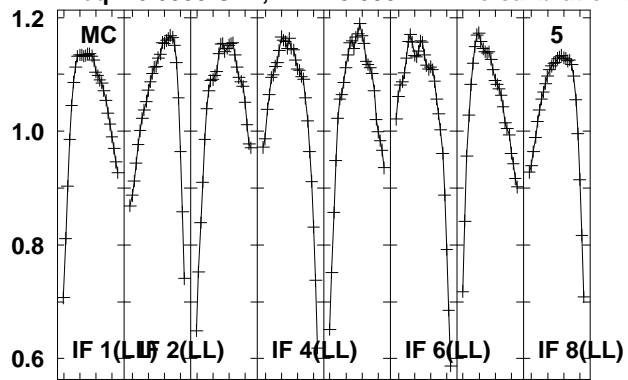

Lower frame: Real Jy
 Total-power spectrum Antenna: *
 Timerange: 00/15:38:55 to 00/15:40:23

Plot file version 221 created 15-MAR-2012 17:33:04

2114-G85 EZ020E 2.UVDATA.1

Freq = 6.6335 GHz, Bw = 8.000 MH No calibration applied and no bandpass applied

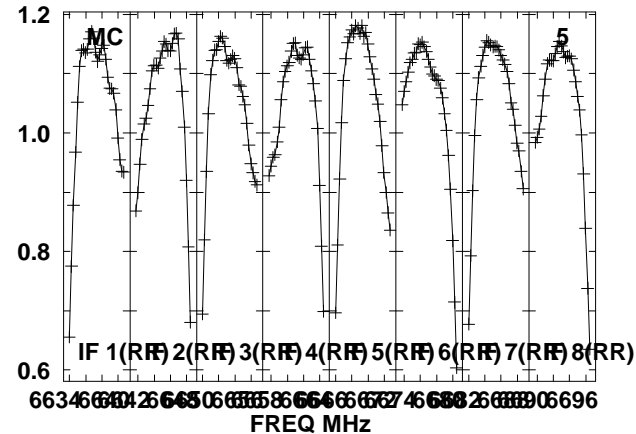
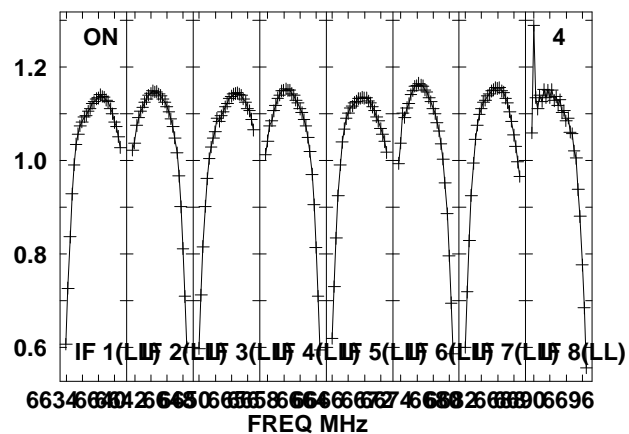
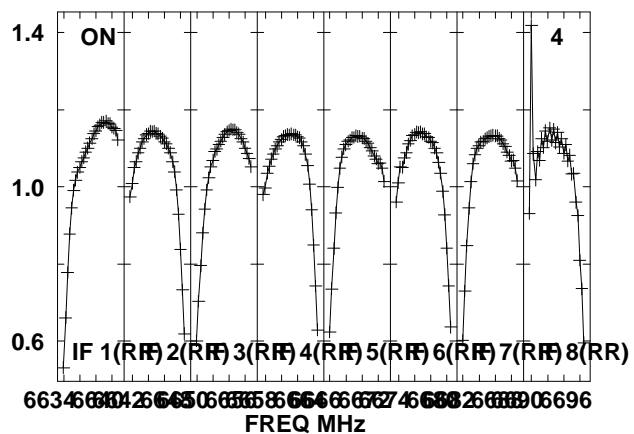
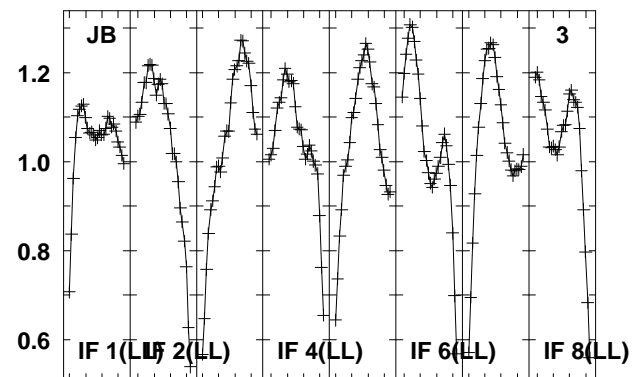
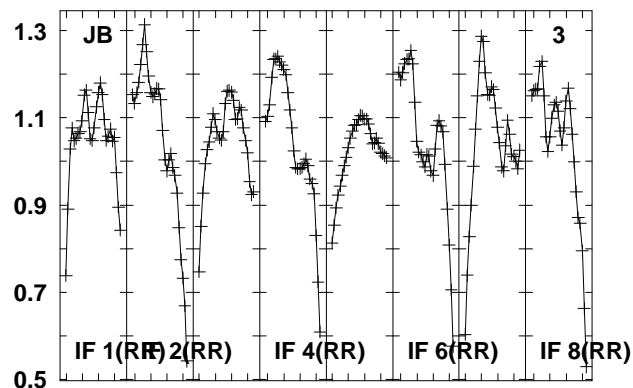
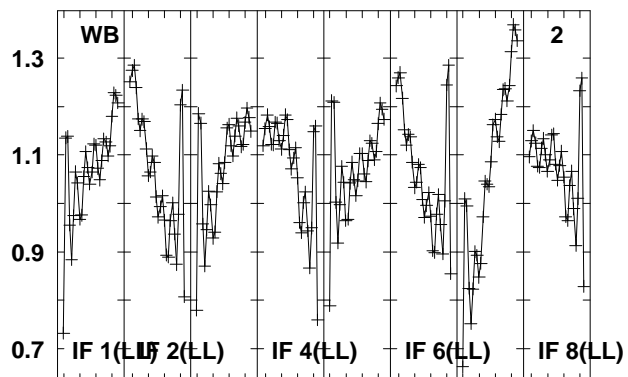
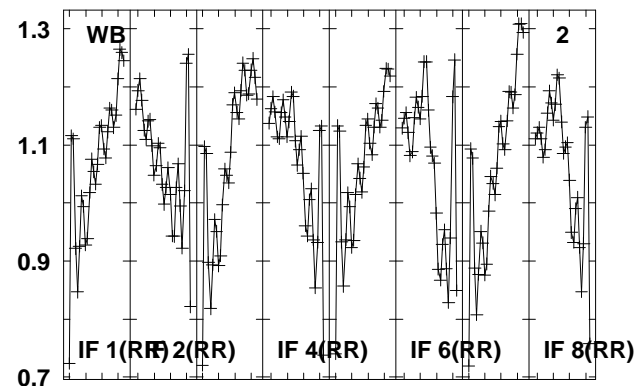
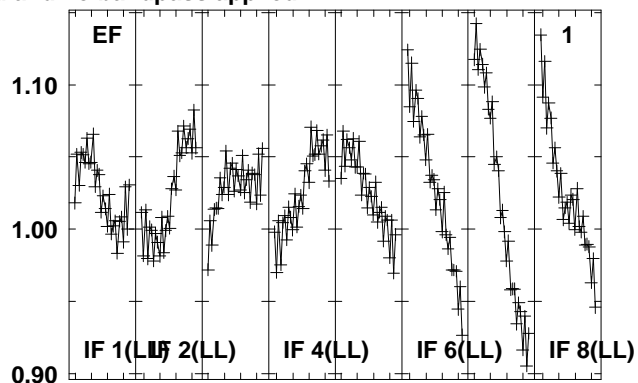
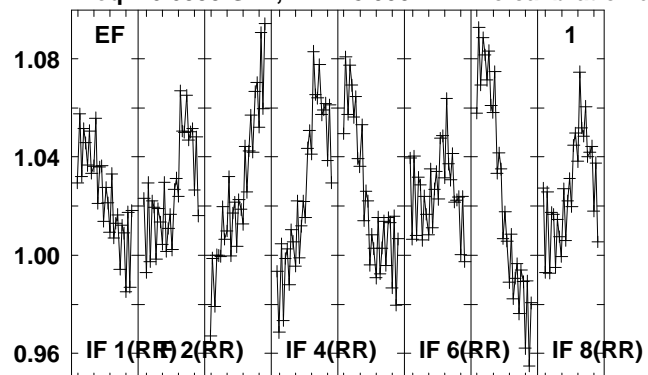

Lower frame: Real Jy
Total-power spectrum Antenna: *
Timerange: 00/15:40:24 to 00/15:41:52

Plot file version 222 created 15-MAR-2012 17:33:04

2114-G85 EZ020E 2.UVDATA.1

Freq = 6.6335 GHz, Bw = 8.000 MH No calibration applied and no bandpass applied

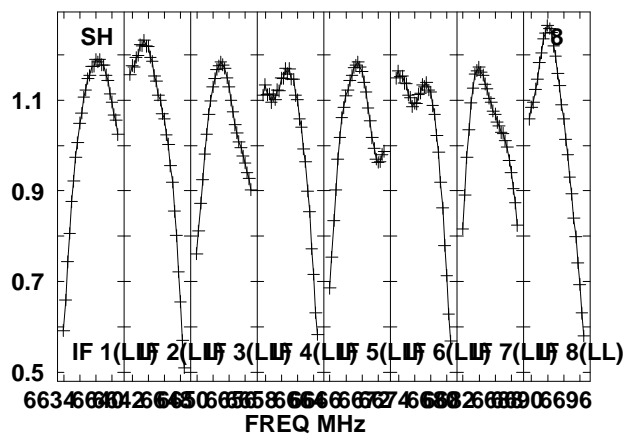
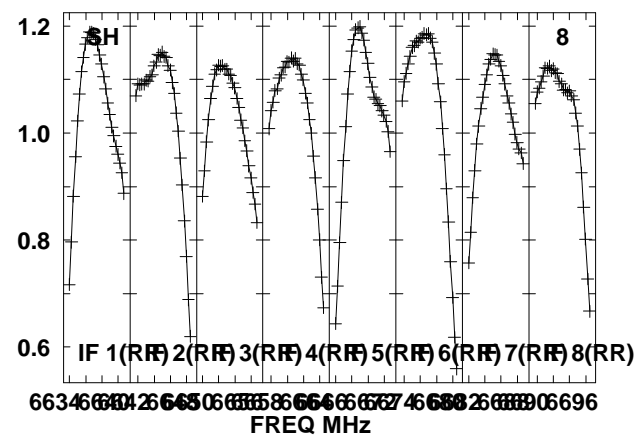
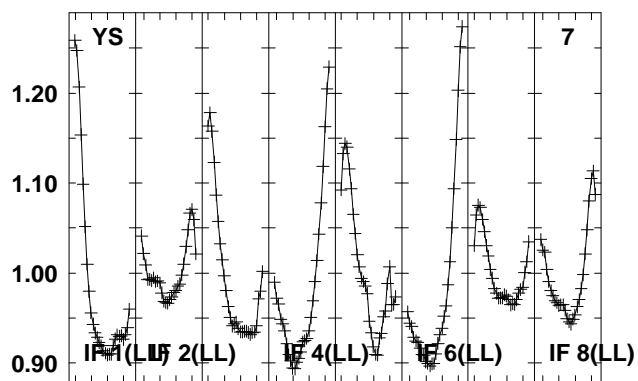
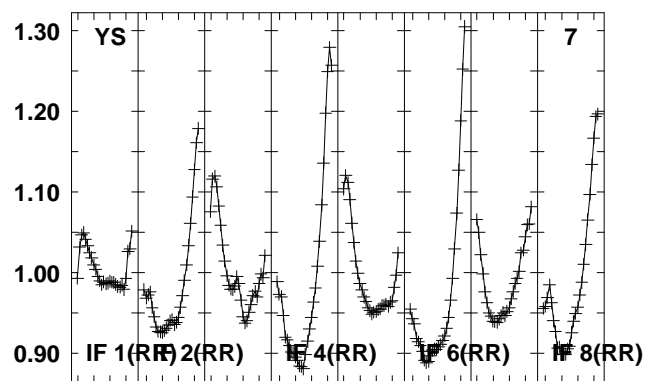
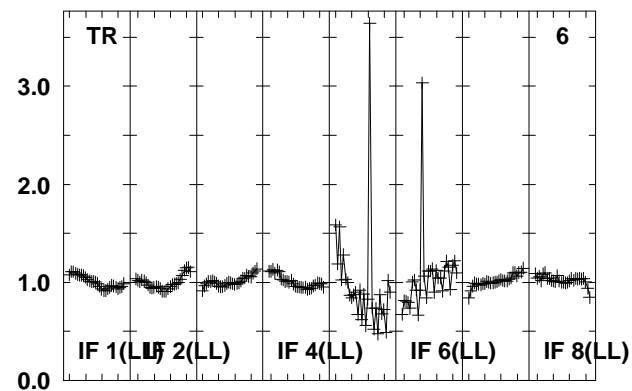
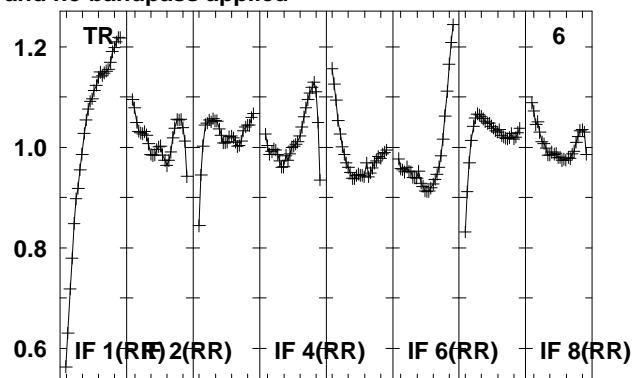
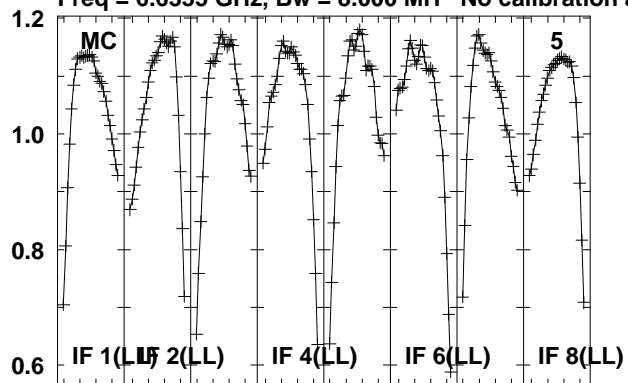

Lower frame: Real Jy

Total-power spectrum Antenna: *

Timerange: 00/15:40:24 to 00/15:41:52

Plot file version 223 created 15-MAR-2012 17:33:05

G85.40 EZ020E 2.UVDATA.1

Freq = 6.6335 GHz, Bw = 8.000 MH No calibration applied and no bandpass applied

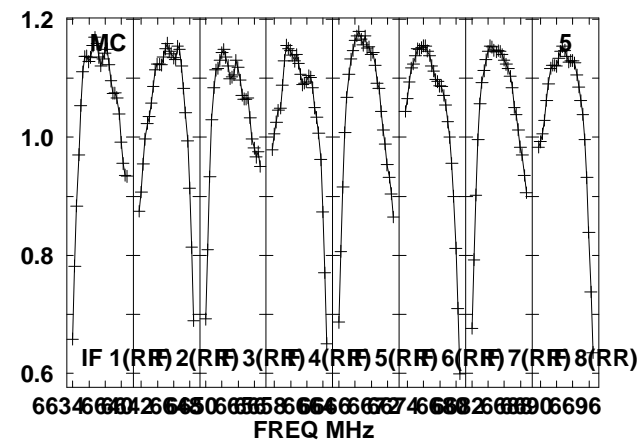
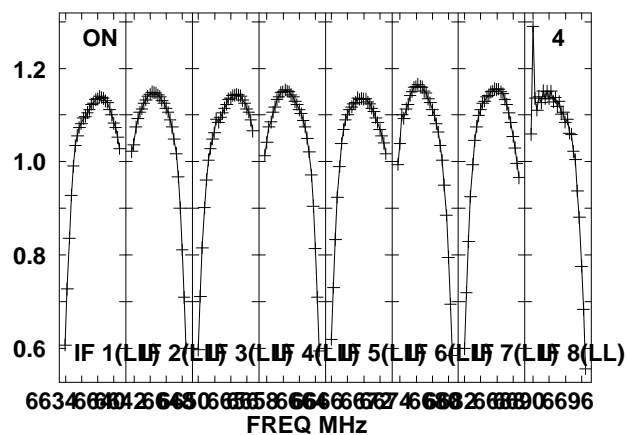
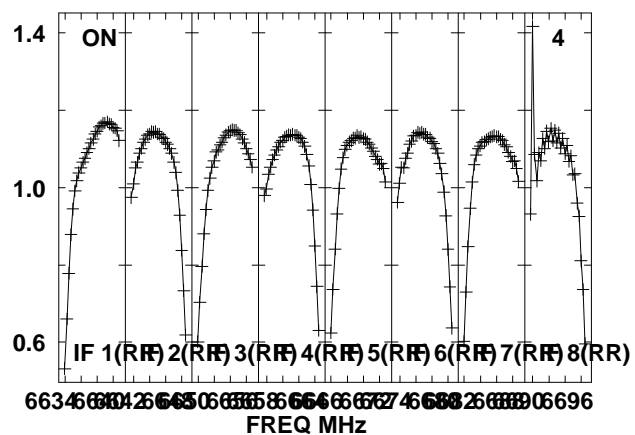
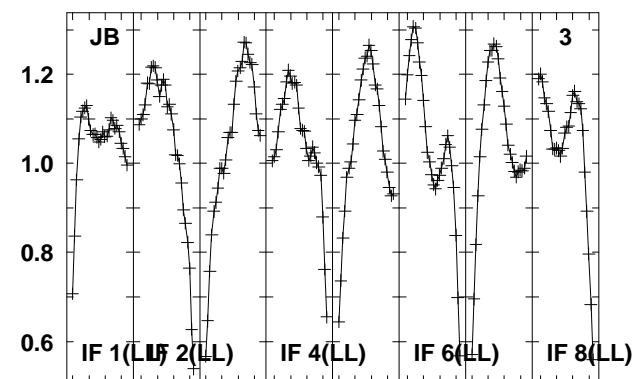
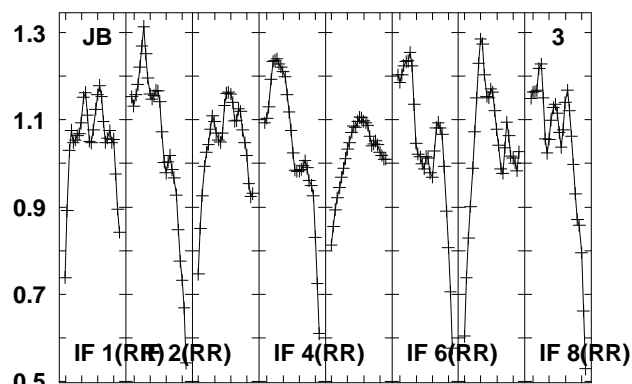
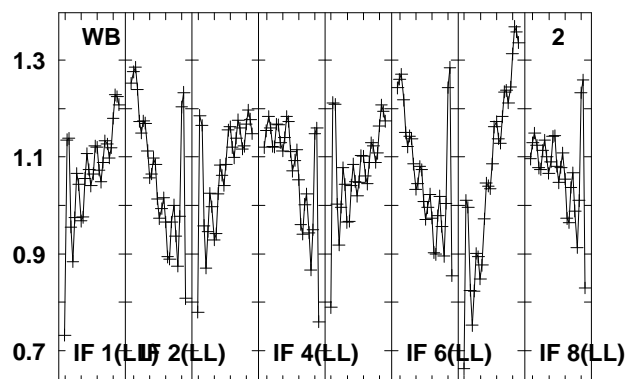
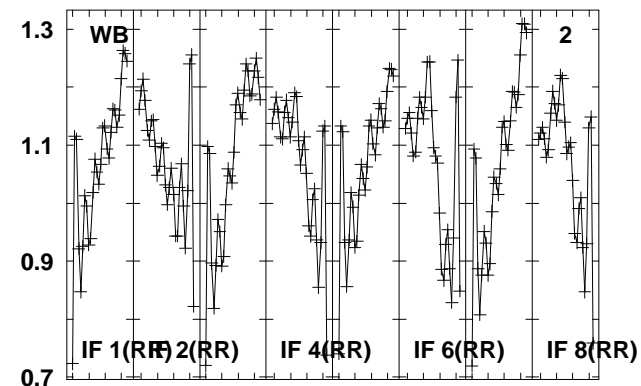
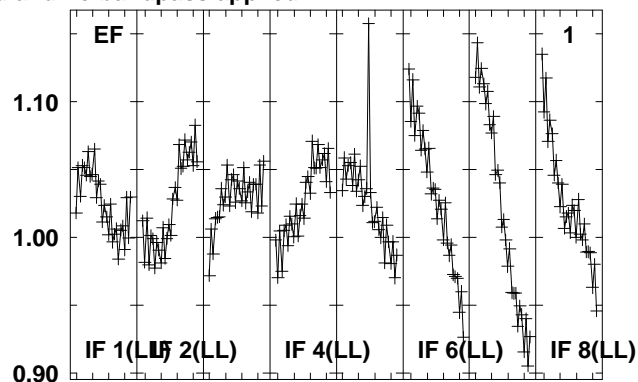
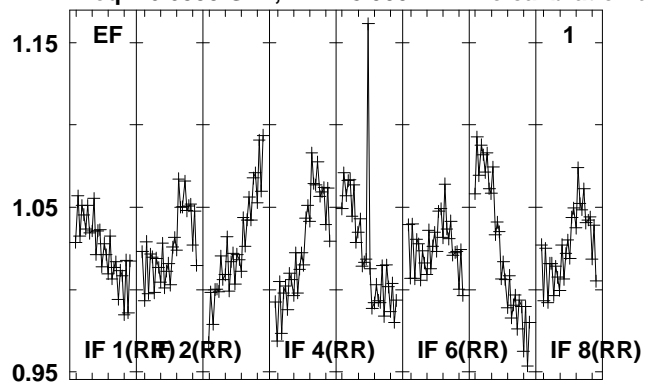

Lower frame: Real Jy

Total-power spectrum Antenna: *

Timerange: 00/15:41:54 to 00/15:43:22

Plot file version 224 created 15-MAR-2012 17:33:05

G85.40 EZ020E 2.UVDATA.1

Freq = 6.6335 GHz, Bw = 8.000 MH No calibration applied and no bandpass applied

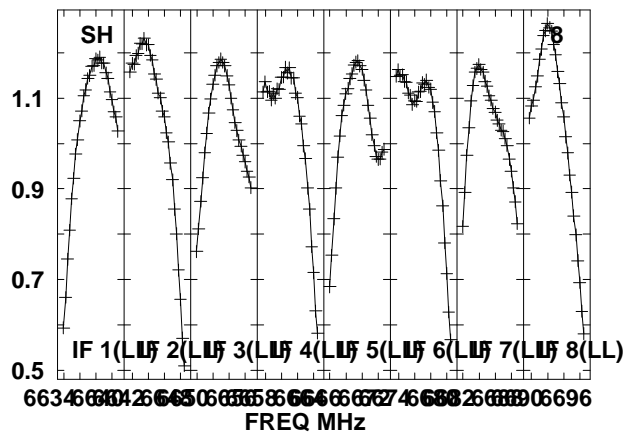
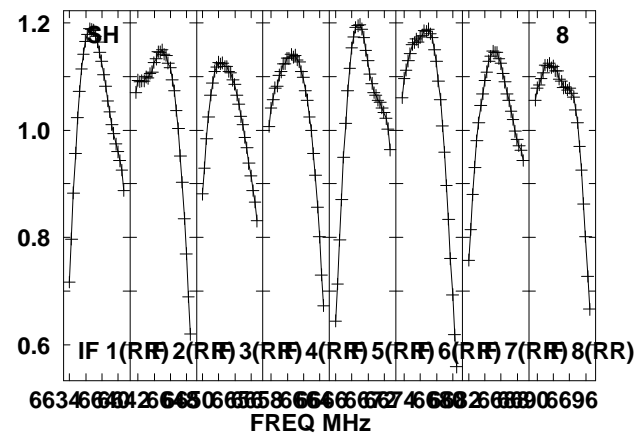
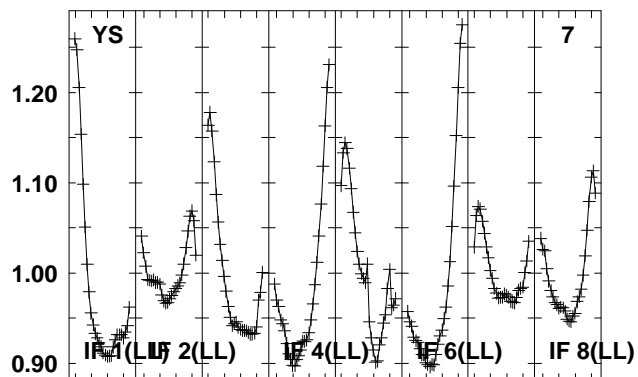
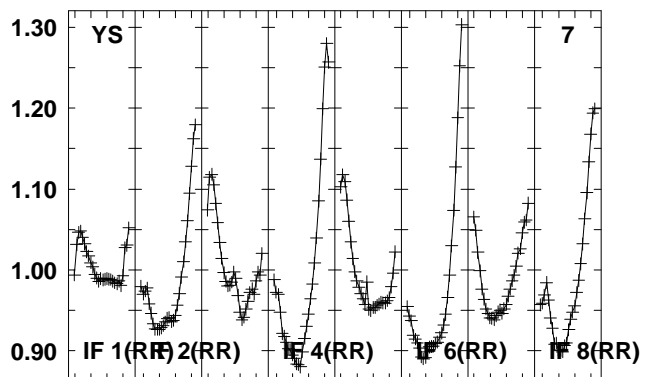
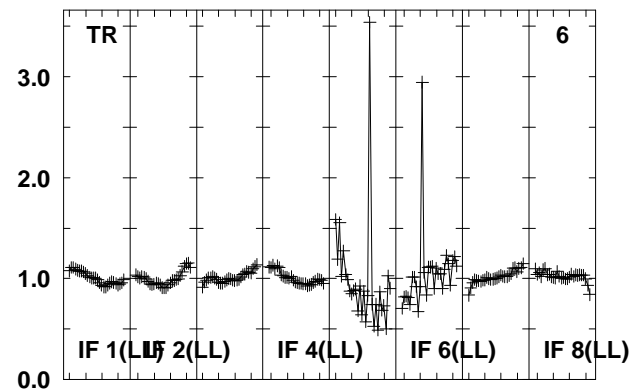
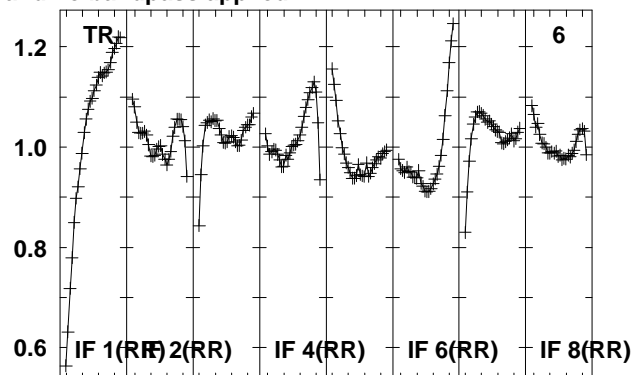
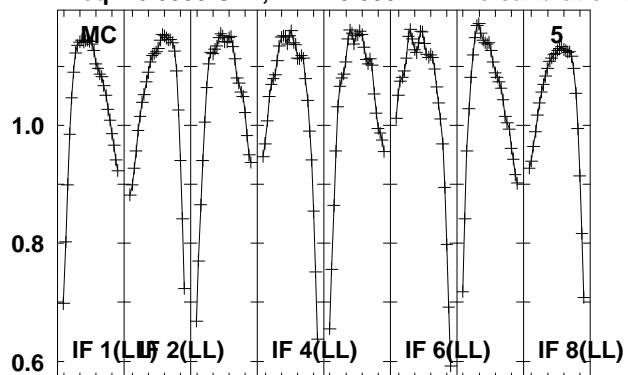

Lower frame: Real Jy

Total-power spectrum Antenna: *

Timerange: 00/15:41:54 to 00/15:43:22

Plot file version 225 created 15-MAR-2012 17:33:06

2102-G85 EZ020E 2.UVDATA.1

Freq = 6.6335 GHz, Bw = 8.000 MH No calibration applied and no bandpass applied

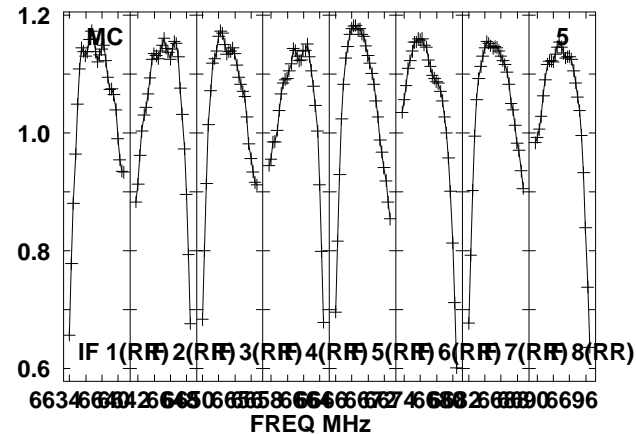
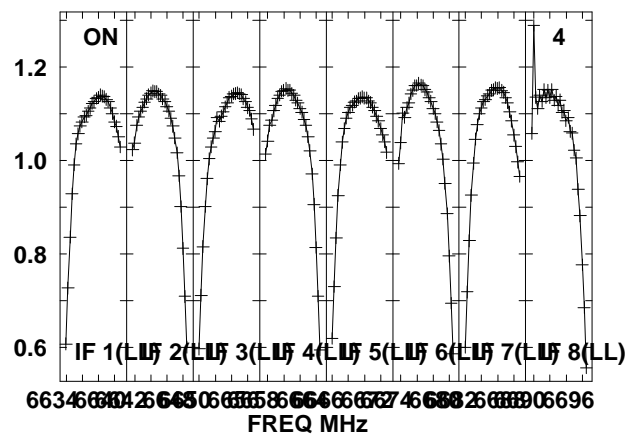
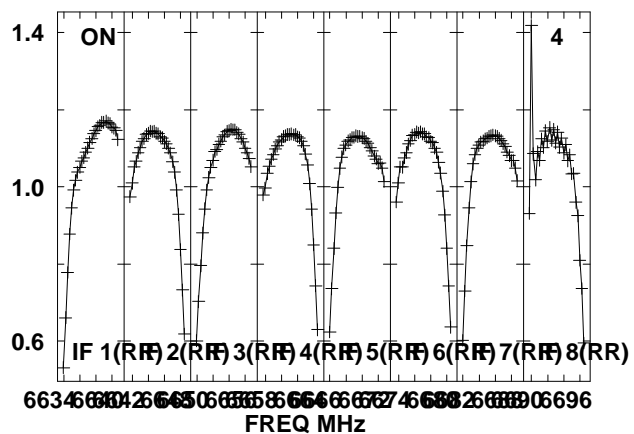
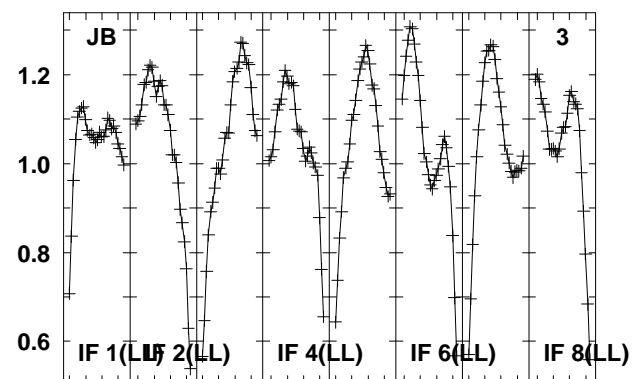
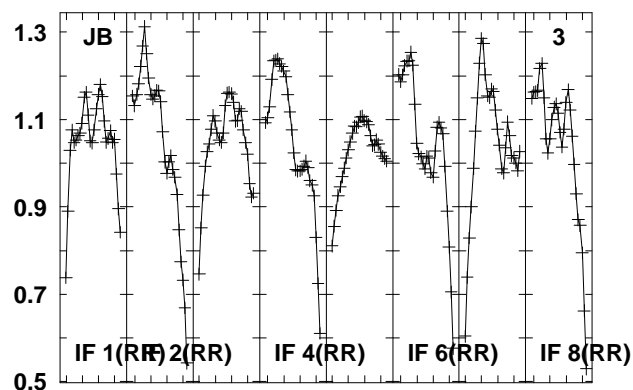
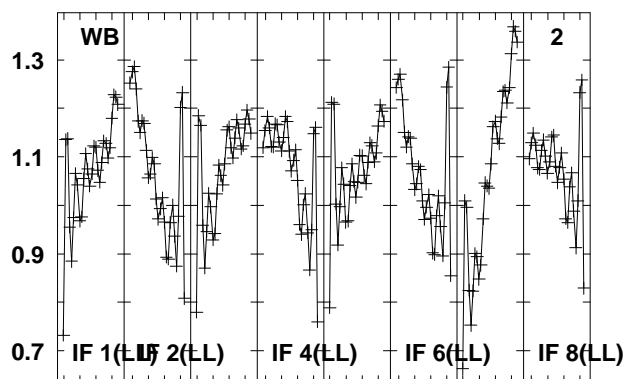
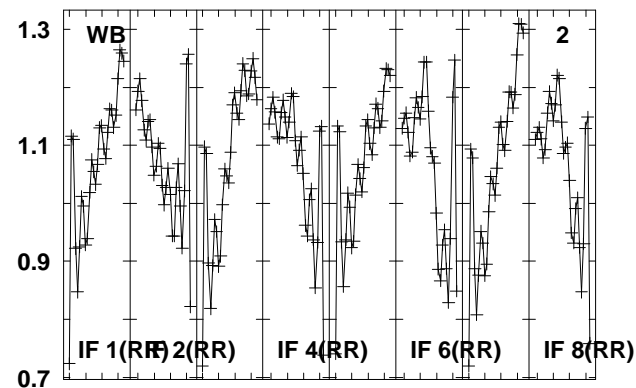
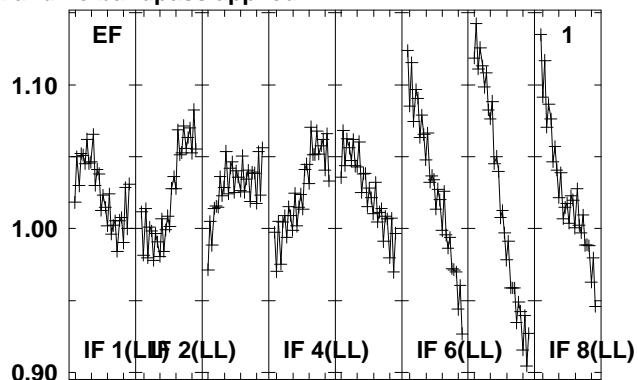
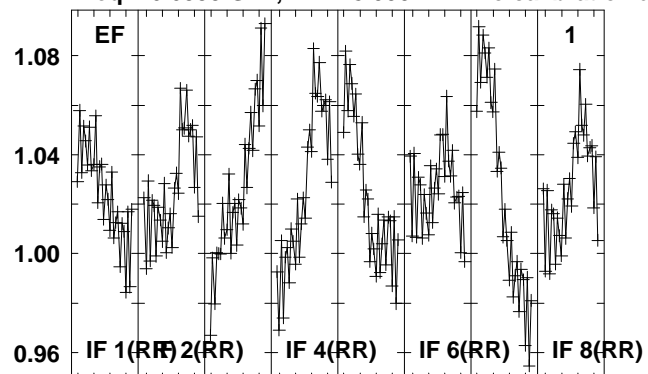

Lower frame: Real Jy
Total-power spectrum Antenna: *
Timerange: 00/15:43:25 to 00/15:44:53

Plot file version 226 created 15-MAR-2012 17:33:07

2102-G85 EZ020E 2.UVDATA.1

Freq = 6.6335 GHz, Bw = 8.000 MH No calibration applied and no bandpass applied

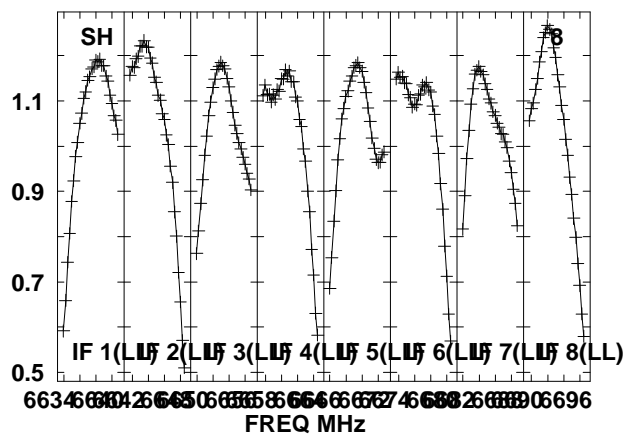
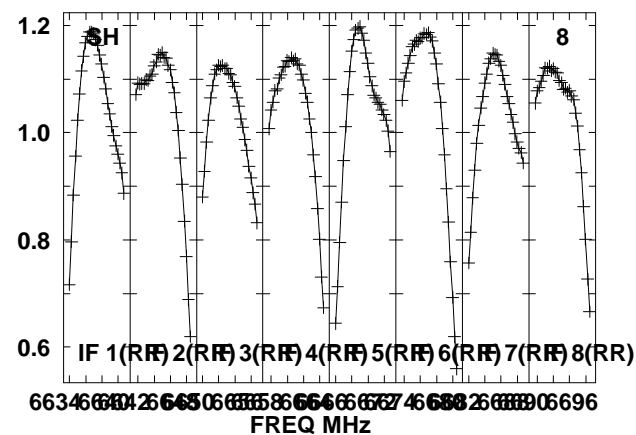
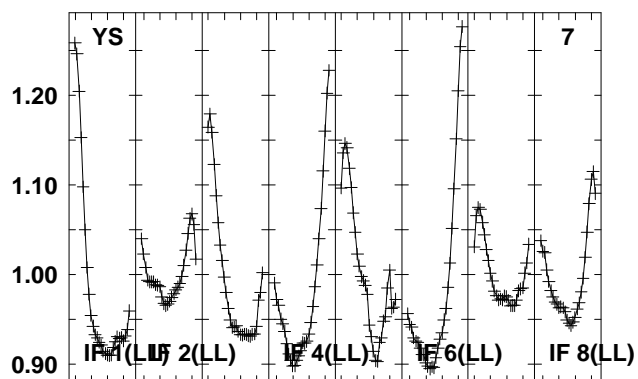
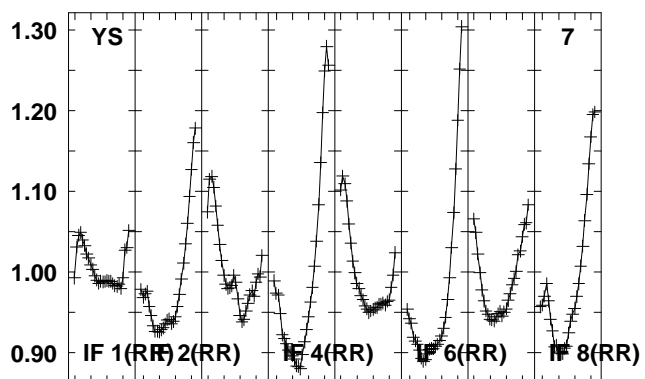
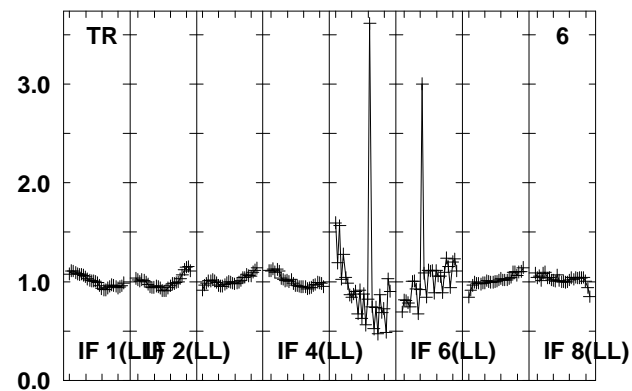
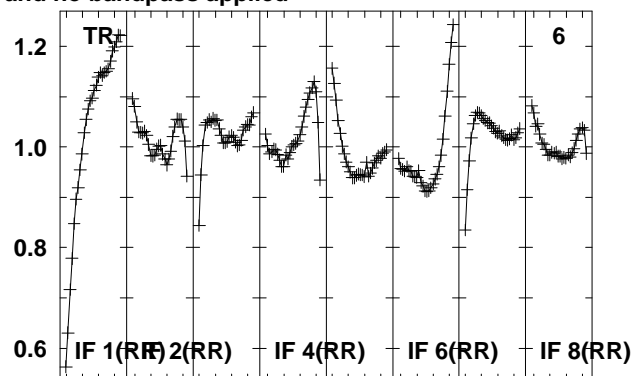
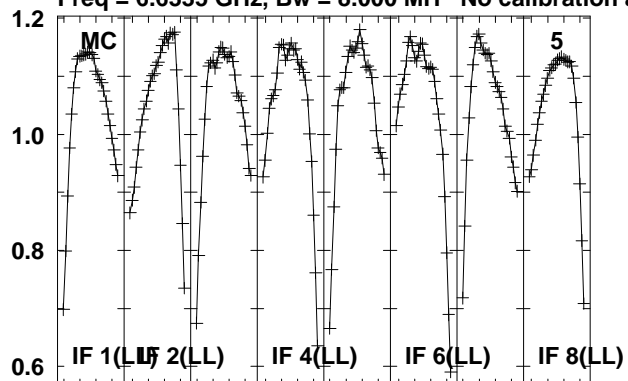

Lower frame: Real Jy

Total-power spectrum Antenna: *

Timerange: 00/15:43:25 to 00/15:44:53

Plot file version 227 created 15-MAR-2012 17:33:08

G85.40 EZ020E 2.UVDATA.1

Freq = 6.6335 GHz, Bw = 8.000 MH No calibration applied and no bandpass applied

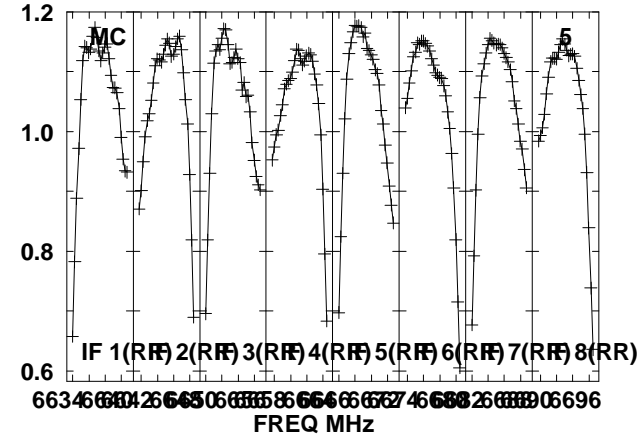
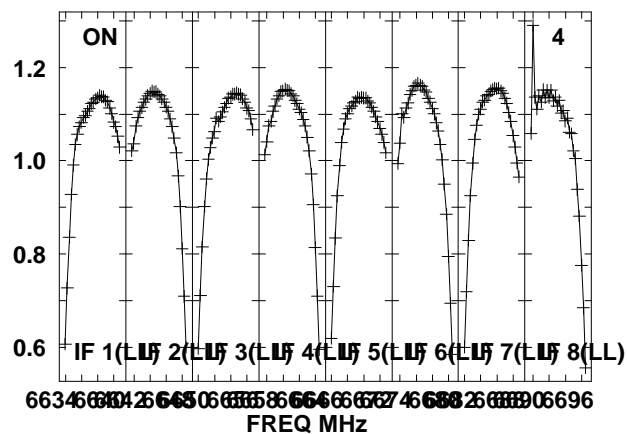
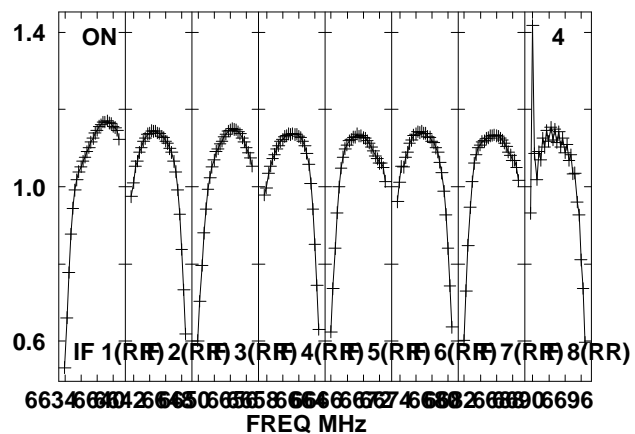
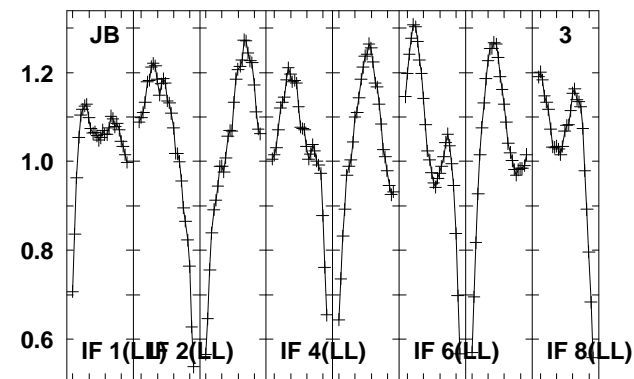
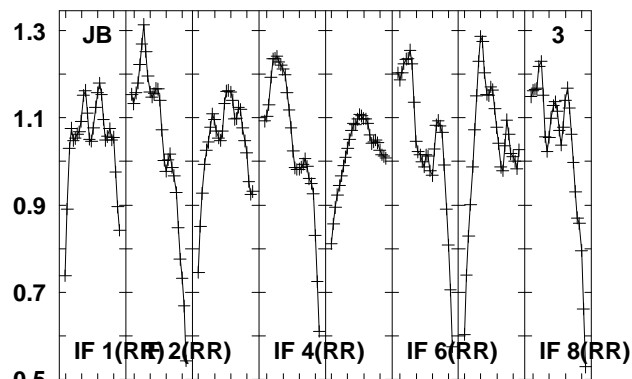
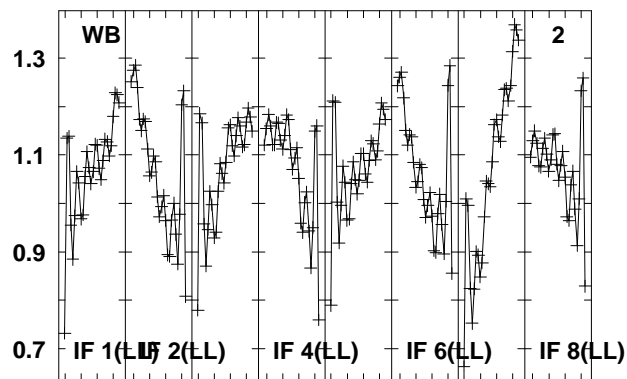
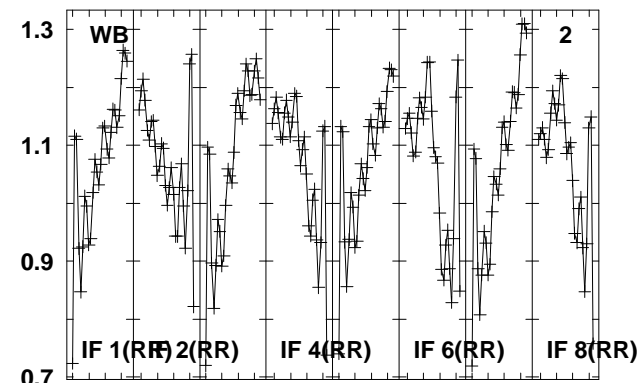
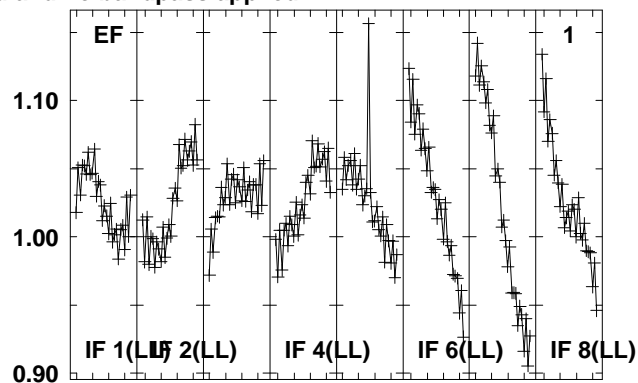
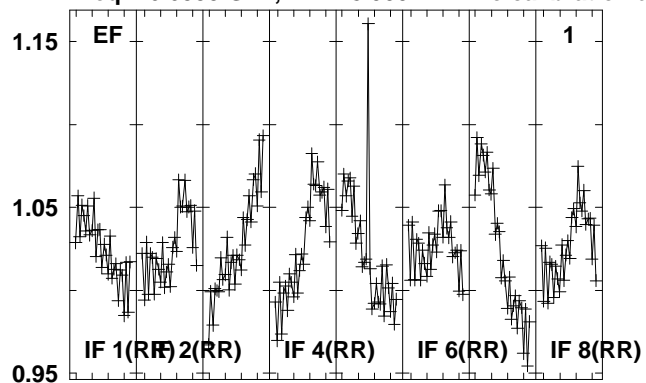

Lower frame: Real Jy
Total-power spectrum Antenna: *
Timerange: 00/15:44:54 to 00/15:46:23

Plot file version 228 created 15-MAR-2012 17:33:08

G85.40 EZ020E 2.UVDATA.1

Freq = 6.6335 GHz, Bw = 8.000 MH No calibration applied and no bandpass applied

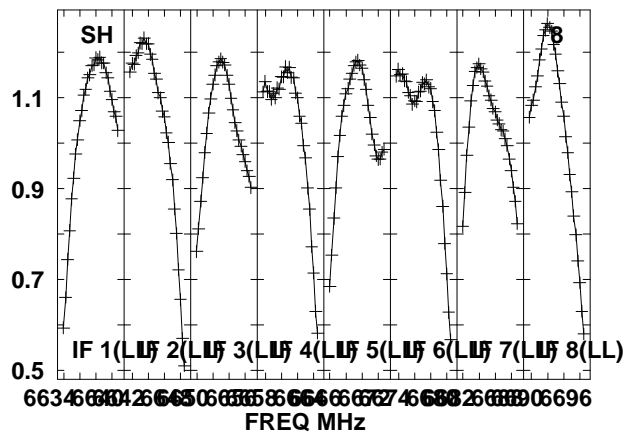
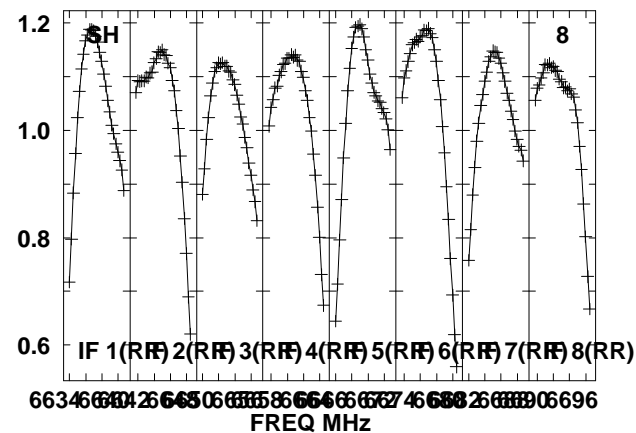
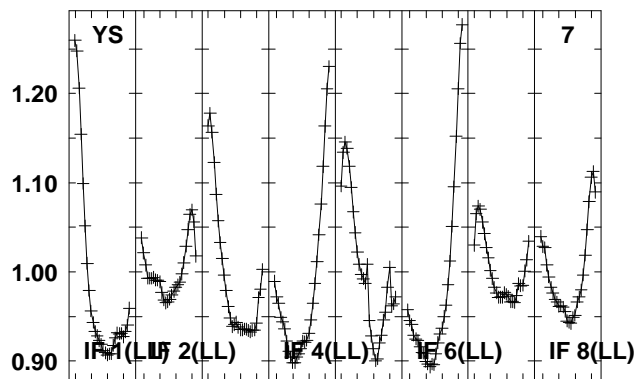
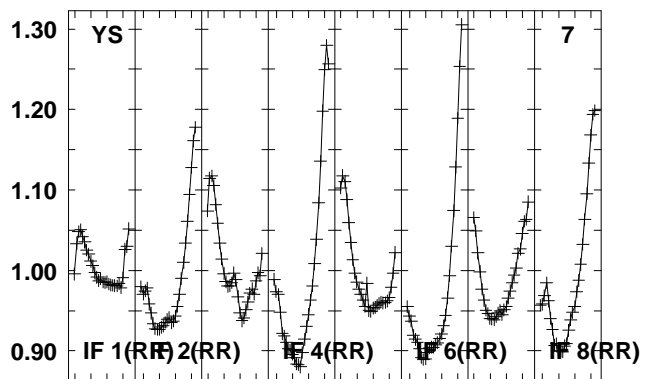
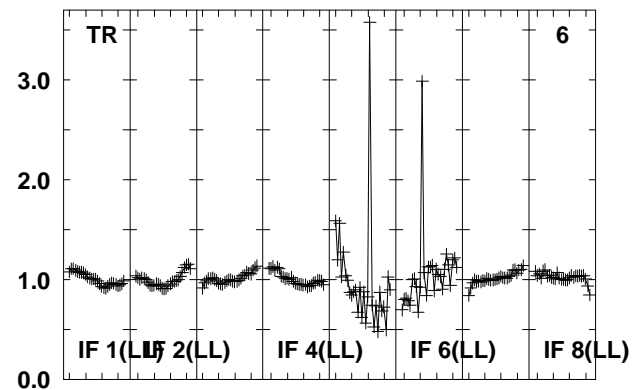
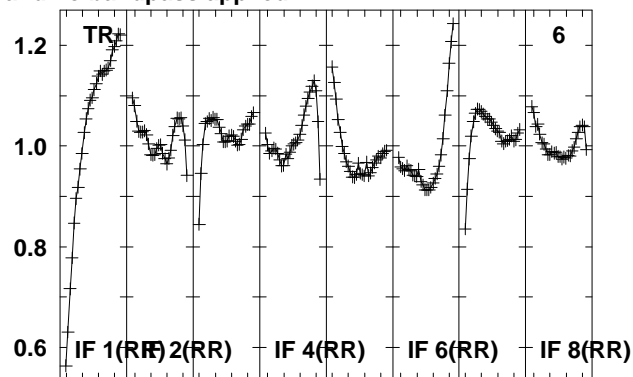
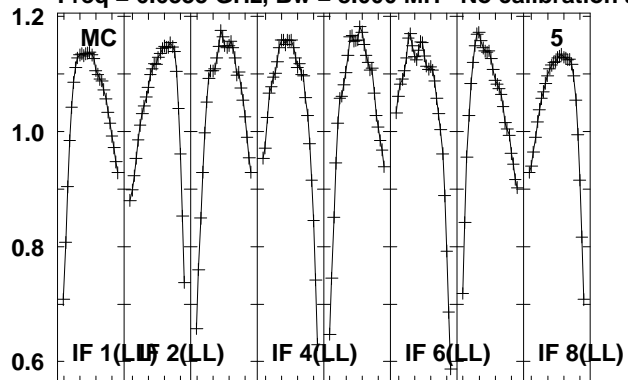

Lower frame: Real Jy
Total-power spectrum Antenna: *
Timerange: 00/15:44:54 to 00/15:46:23

Plot file version 229 created 15-MAR-2012 17:33:09

2114-G85 EZ020E 2.UVDATA.1

Freq = 6.6335 GHz, Bw = 8.000 MH No calibration applied and no bandpass applied

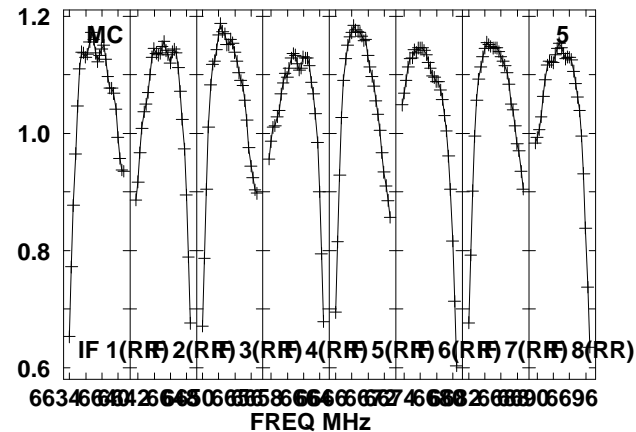
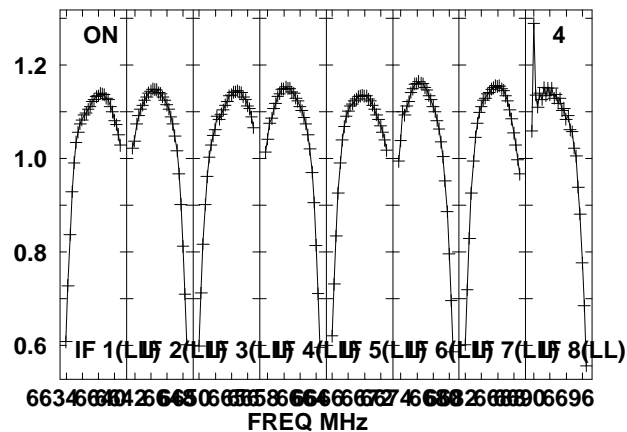
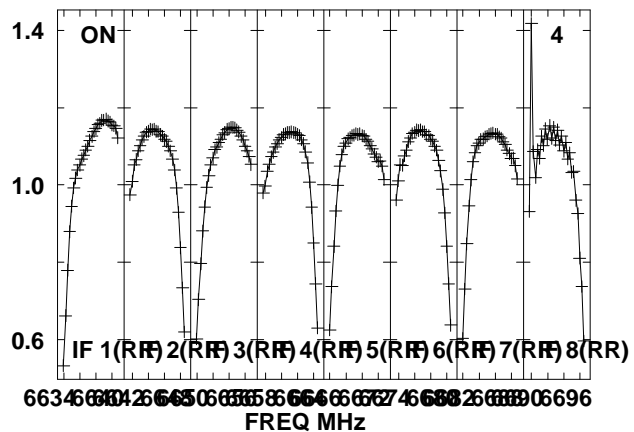
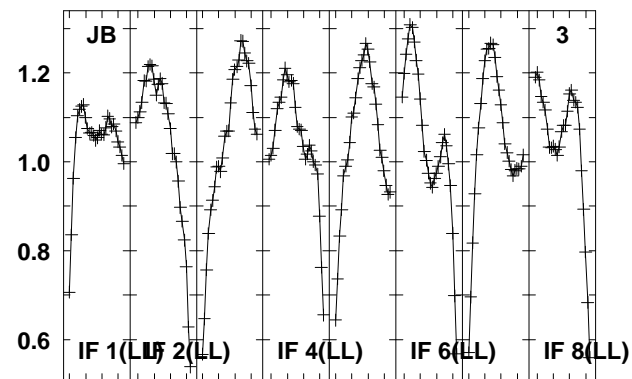
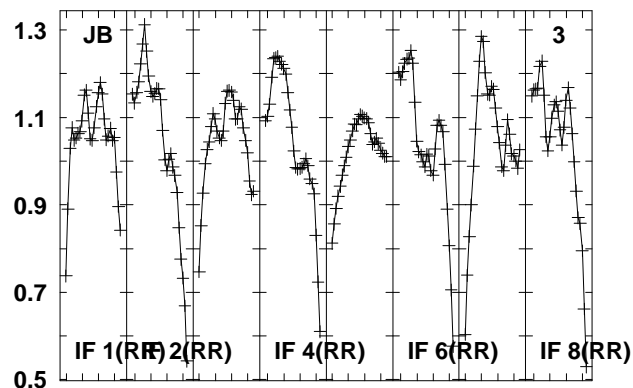
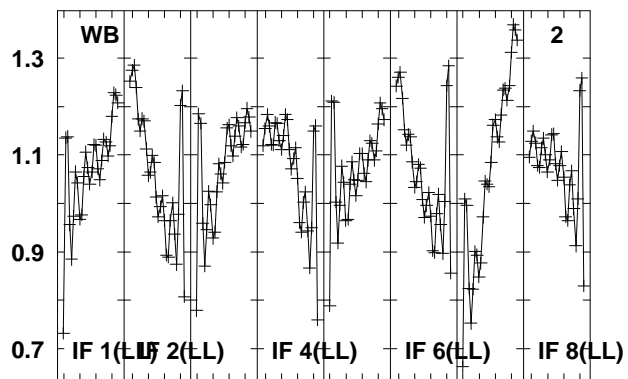
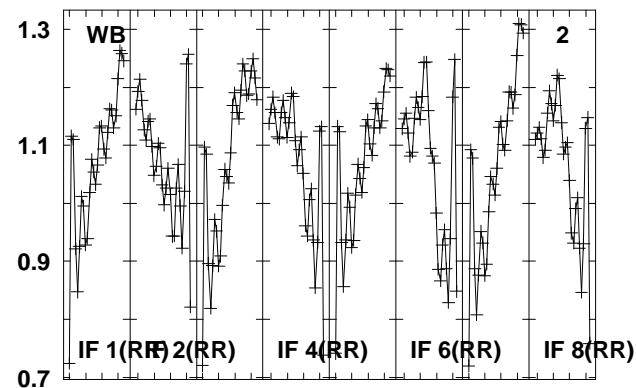
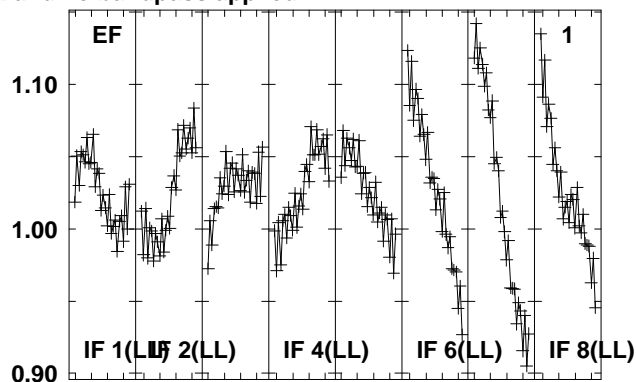
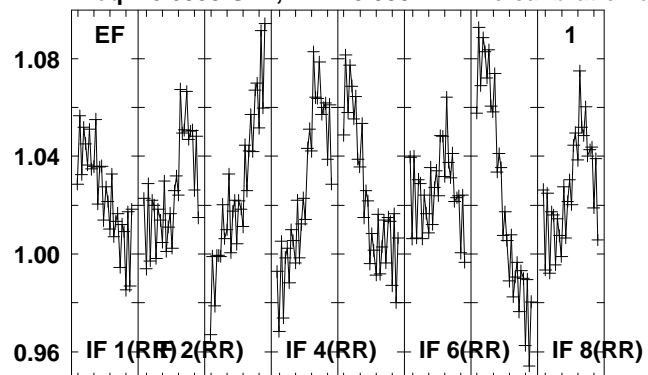

Lower frame: Real Jy

Total-power spectrum Antenna: *

Timerange: 00/15:46:24 to 00/15:47:52

Plot file version 230 created 15-MAR-2012 17:33:10

2114-G85 EZ020E 2.UVDATA.1

Freq = 6.6335 GHz, Bw = 8.000 MH No calibration applied and no bandpass applied

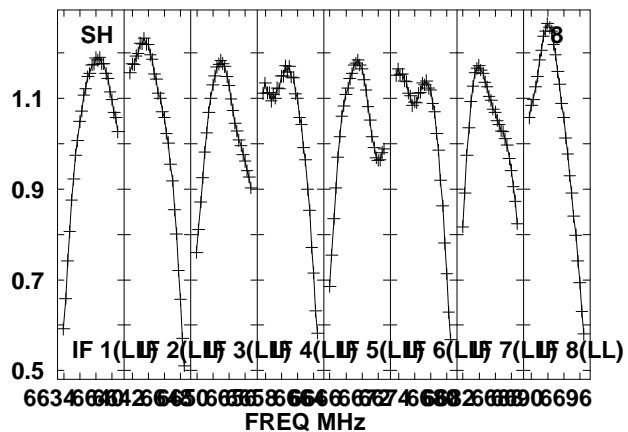
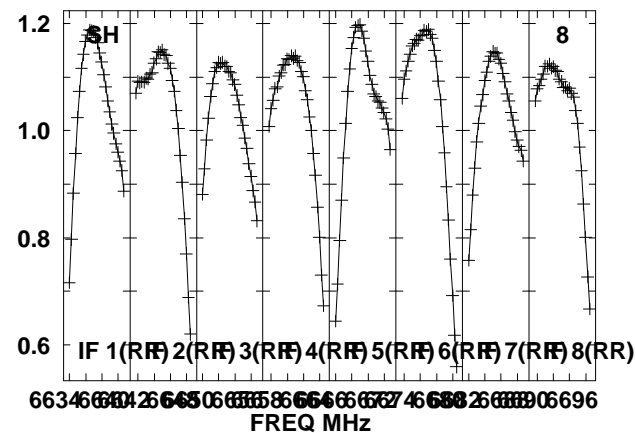
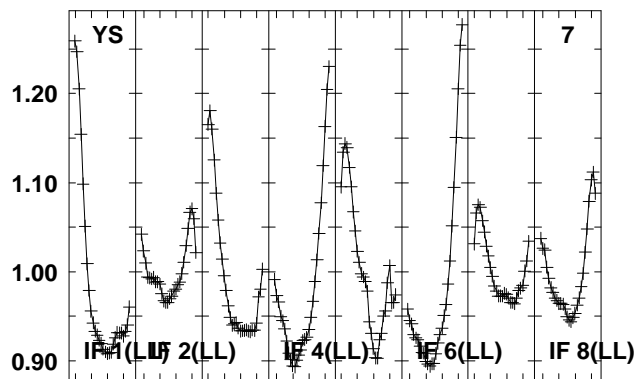
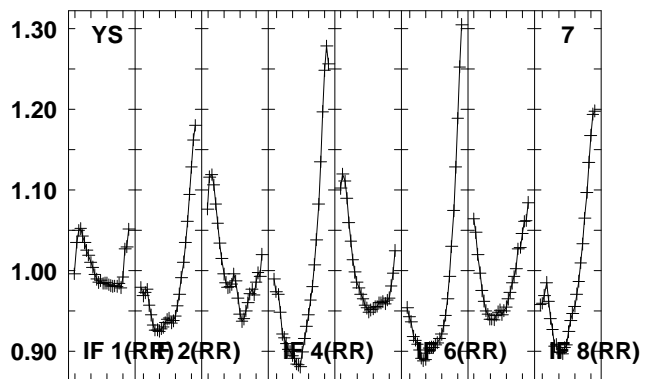
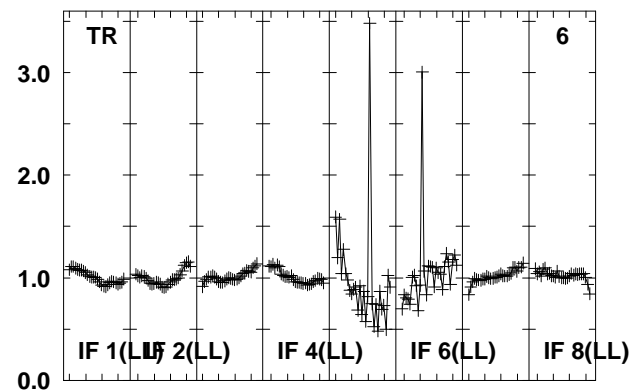
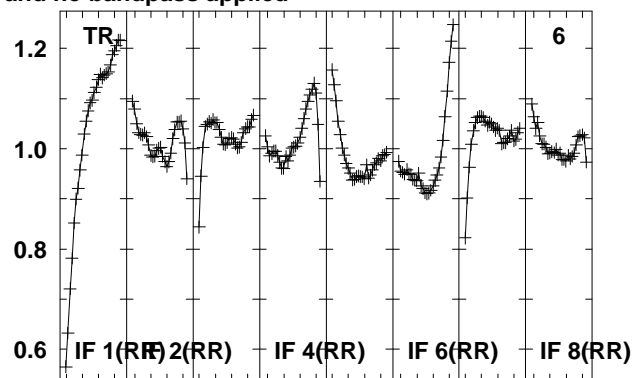
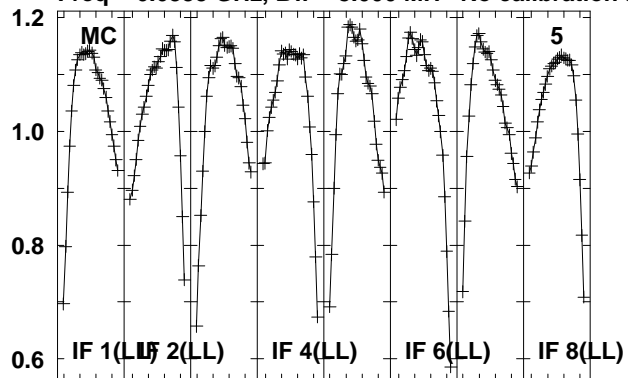

Lower frame: Real Jy

Total-power spectrum Antenna: *

Timerange: 00/15:46:24 to 00/15:47:52

Plot file version 231 created 15-MAR-2012 17:33:11

G85.40 EZ020E 2.UVDATA.1

Freq = 6.6335 GHz, Bw = 8.000 MH No calibration applied and no bandpass applied

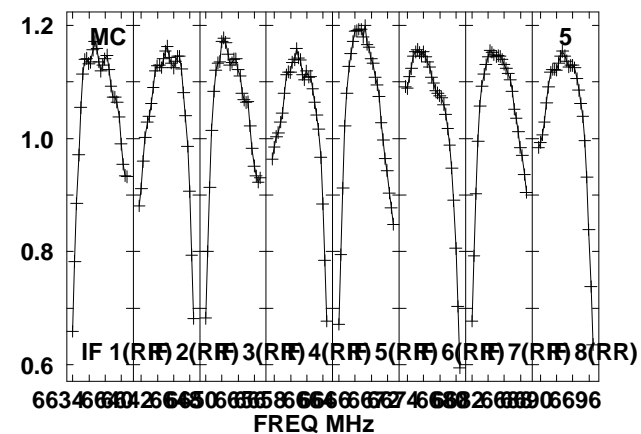
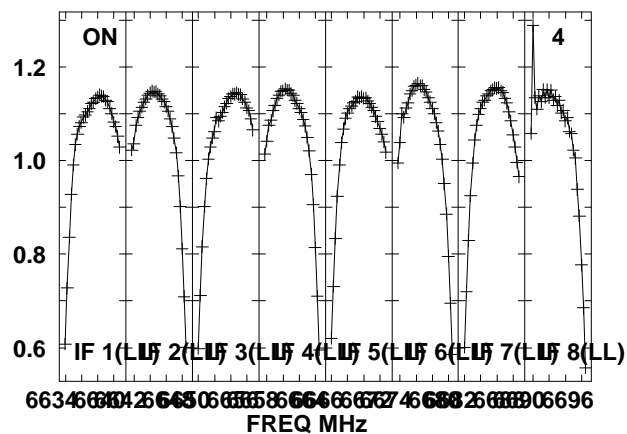
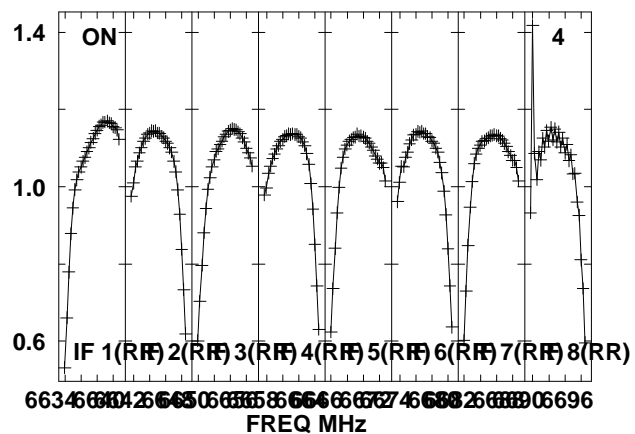
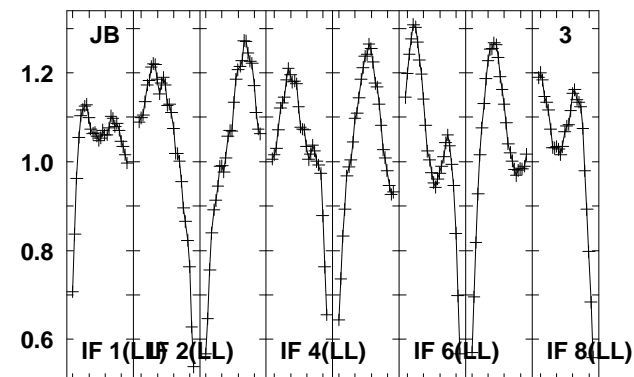
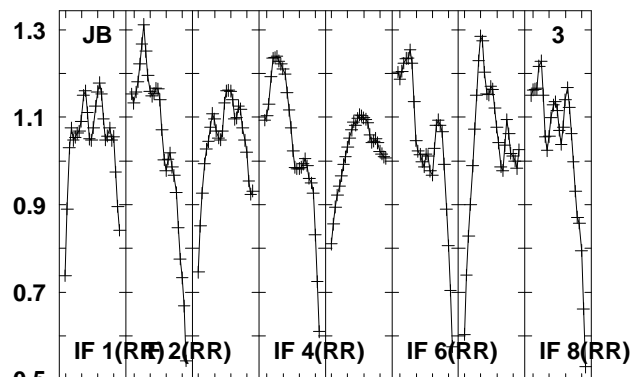
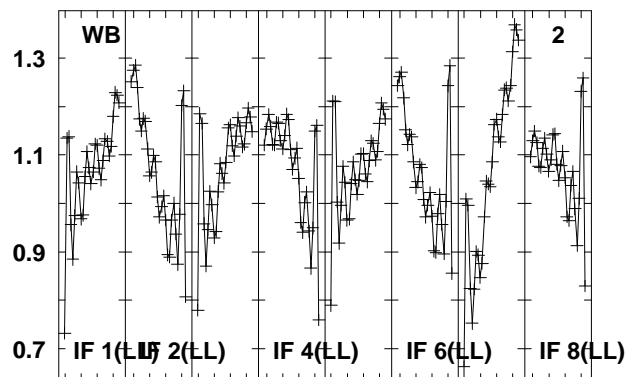
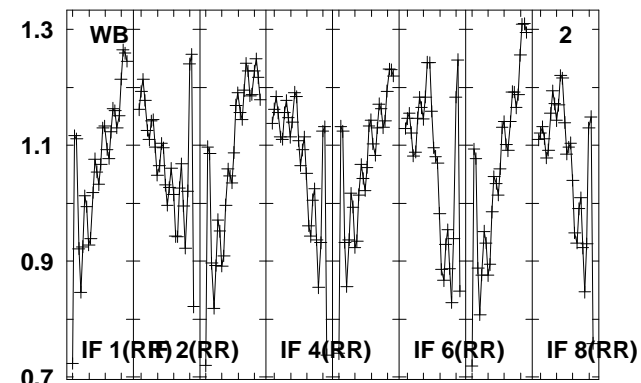
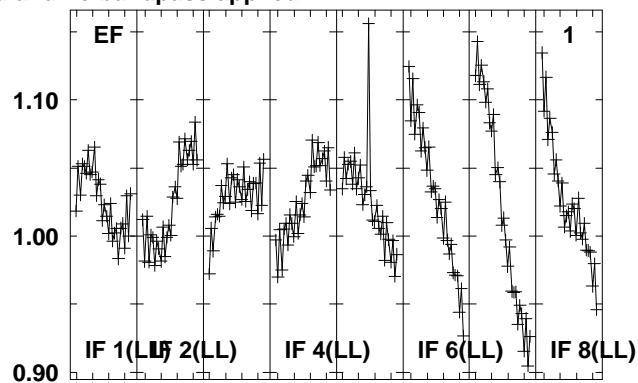
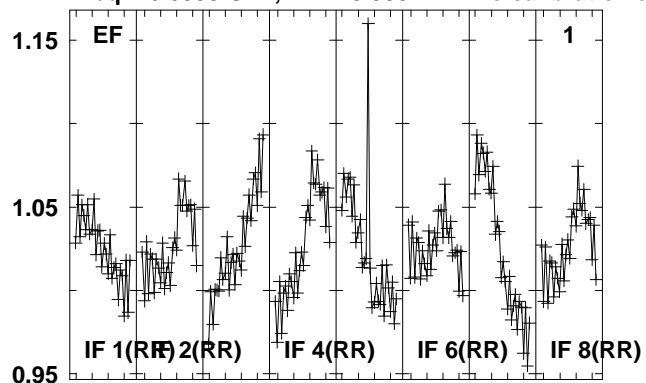

Lower frame: Real Jy
Total-power spectrum Antenna: *
Timerange: 00/15:47:54 to 00/15:49:22

Plot file version 232 created 15-MAR-2012 17:33:12

G85.40 EZ020E 2.UVDATA.1

Freq = 6.6335 GHz, Bw = 8.000 MH No calibration applied and no bandpass applied

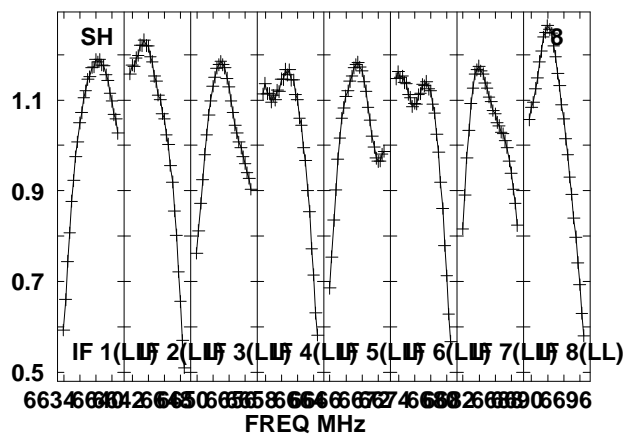
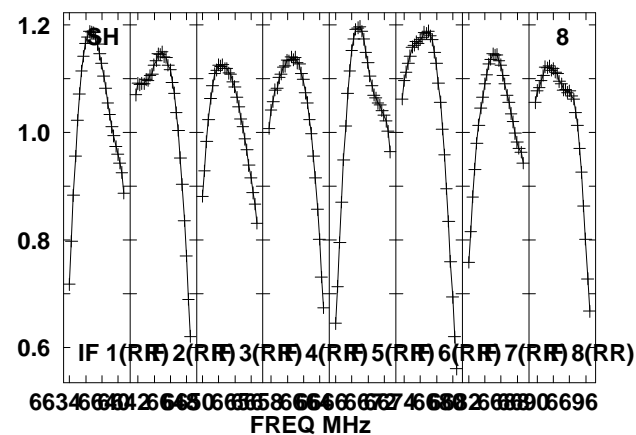
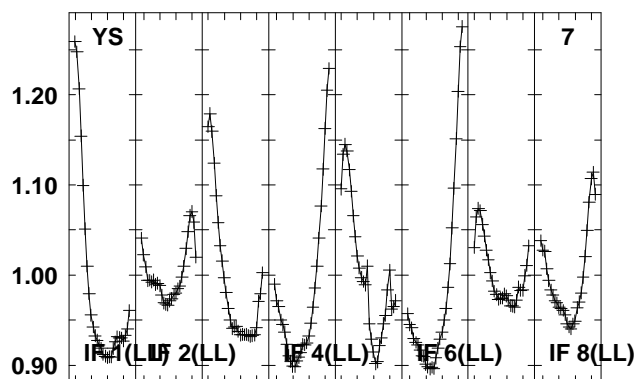
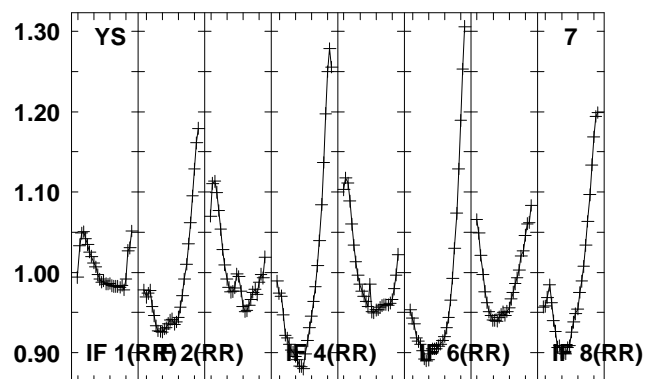
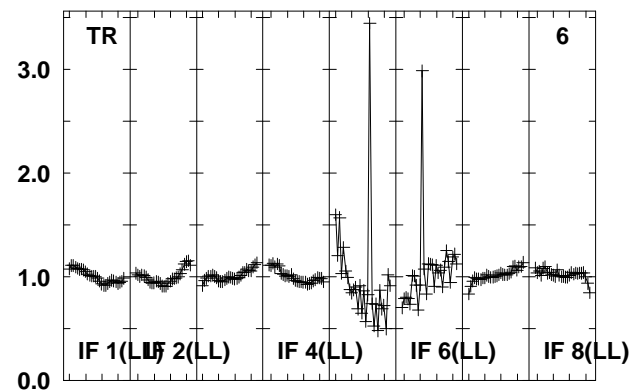
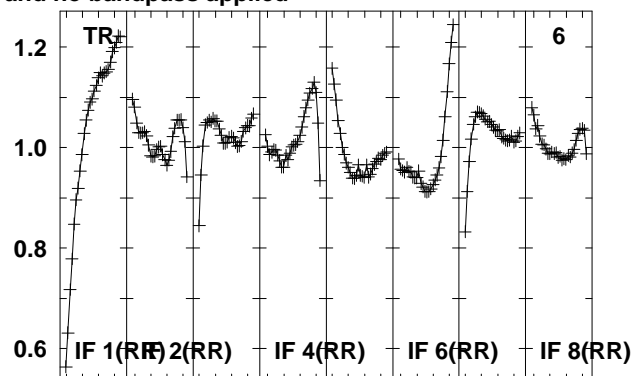
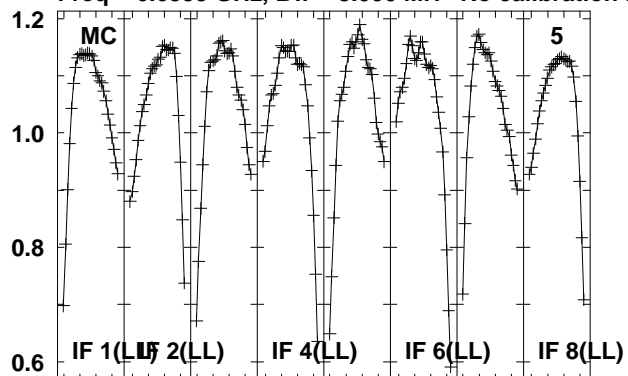

Lower frame: Real Jy

Total-power spectrum Antenna: *

Timerange: 00/15:47:54 to 00/15:49:22

Plot file version 233 created 15-MAR-2012 17:33:13

2102-G85 EZ020E 2.UVDATA.1

Freq = 6.6335 GHz, Bw = 8.000 MH No calibration applied and no bandpass applied

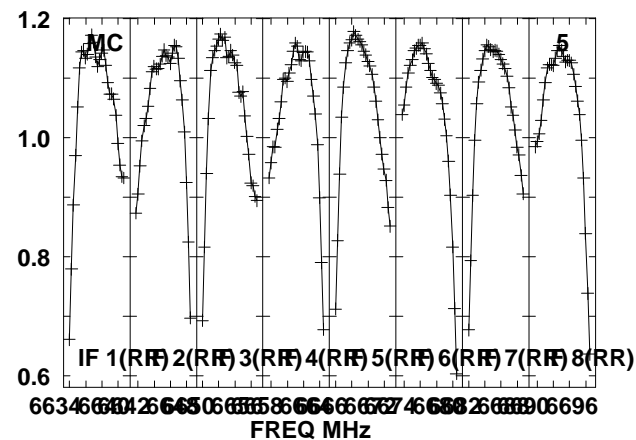
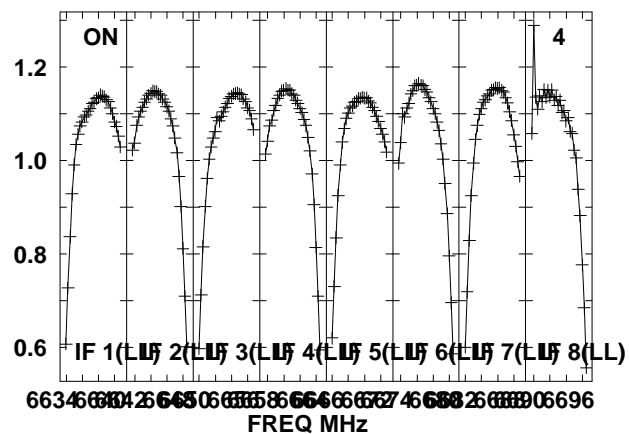
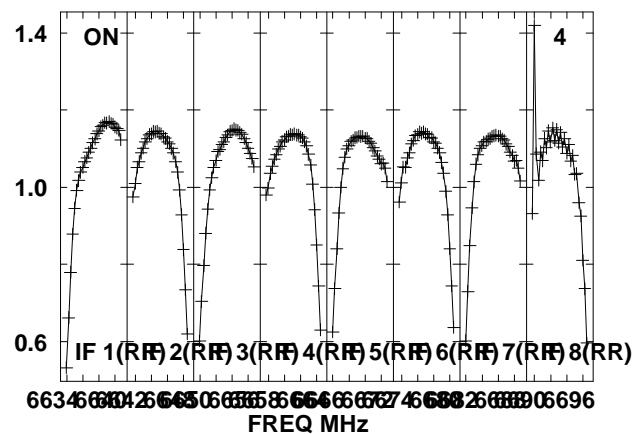
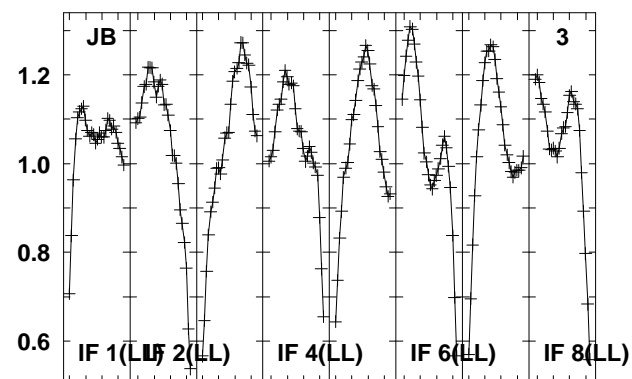
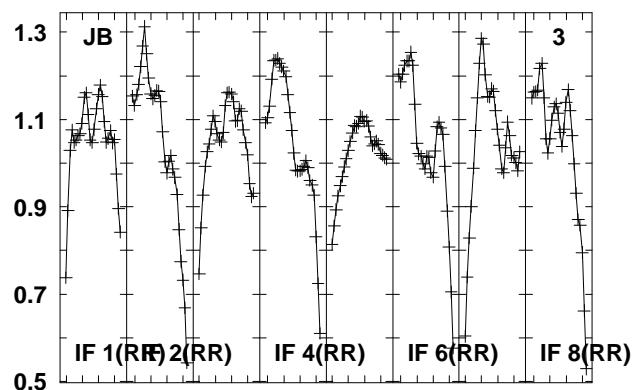
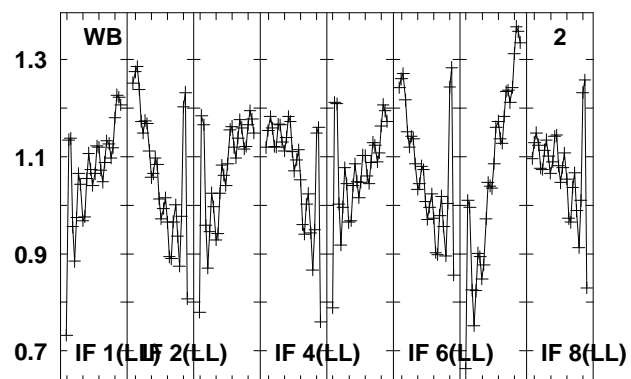
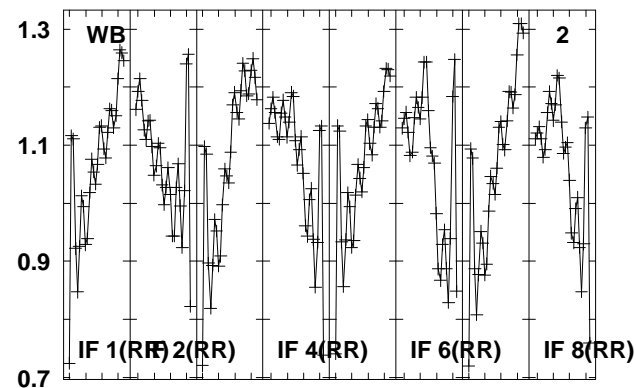
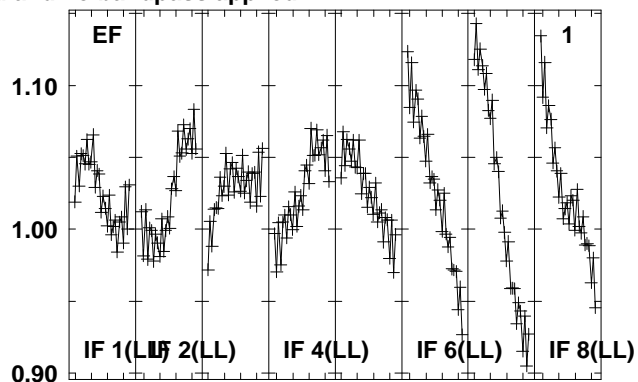
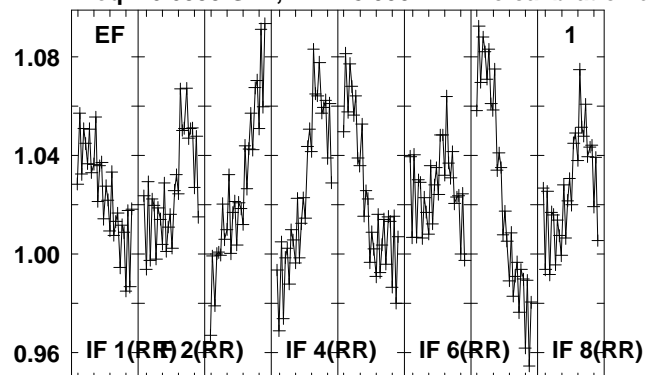

Lower frame: Real Jy

Total-power spectrum Antenna: *

Timerange: 00/15:49:25 to 00/15:50:53

Plot file version 234 created 15-MAR-2012 17:33:13

2102-G85 EZ020E 2.UVDATA.1

Freq = 6.6335 GHz, Bw = 8.000 MH No calibration applied and no bandpass applied

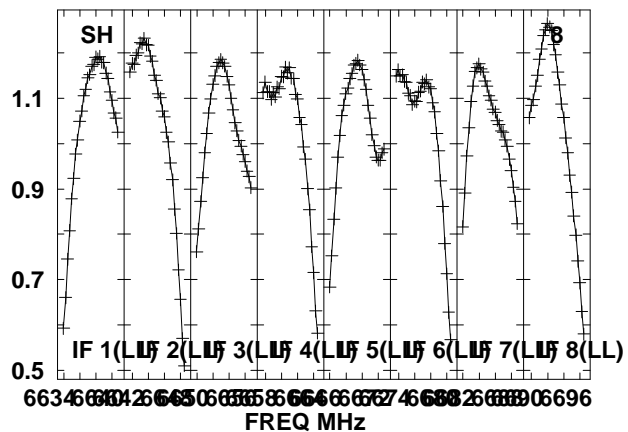
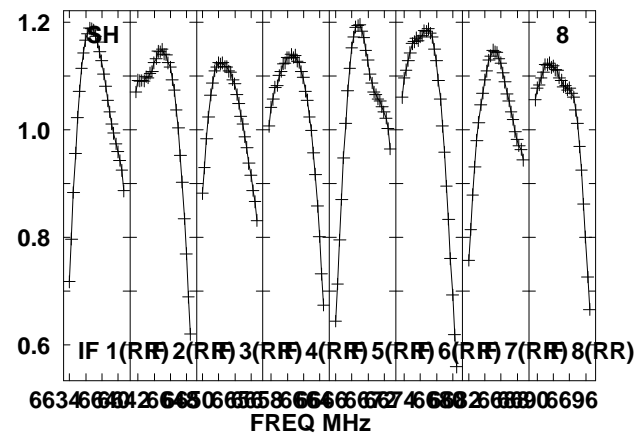
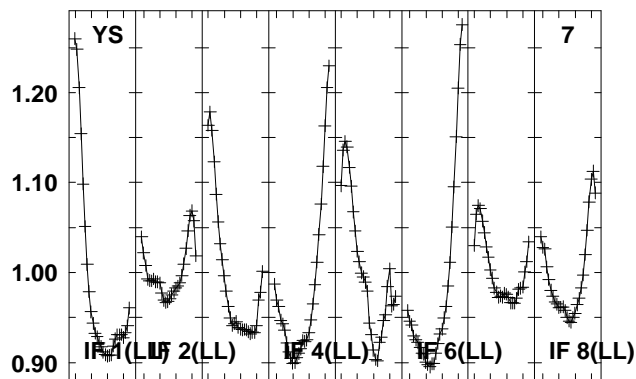
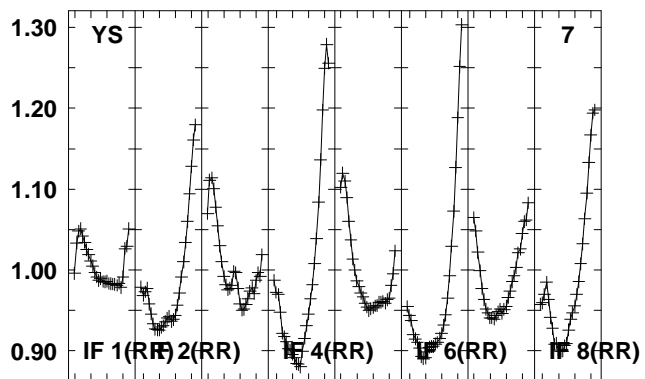
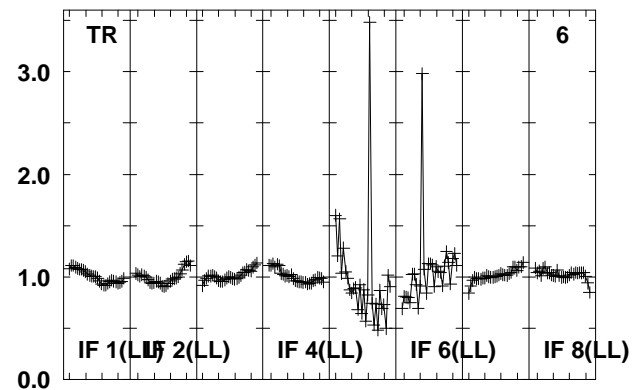
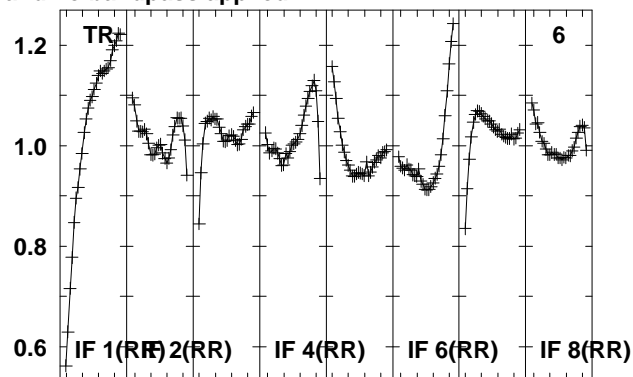
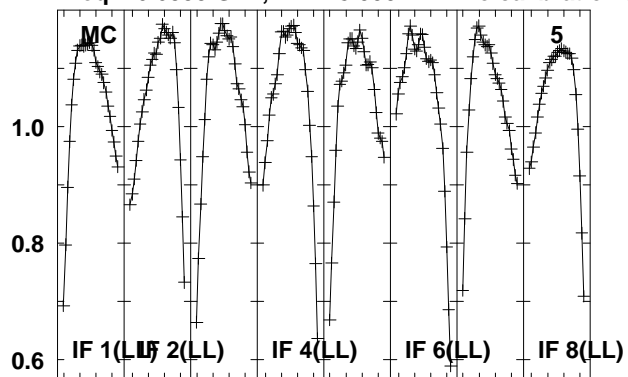

Lower frame: Real Jy

Total-power spectrum Antenna: *

Timerange: 00/15:49:25 to 00/15:50:53

Plot file version 235 created 15-MAR-2012 17:33:15

G85.40 EZ020E 2.UVDATA.1

Freq = 6.6335 GHz, Bw = 8.000 MH No calibration applied and no bandpass applied

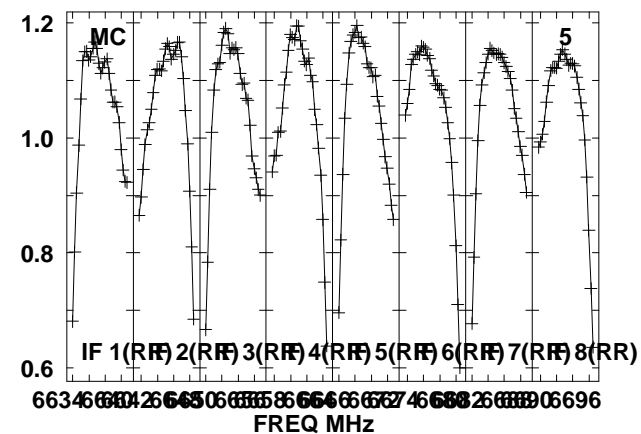
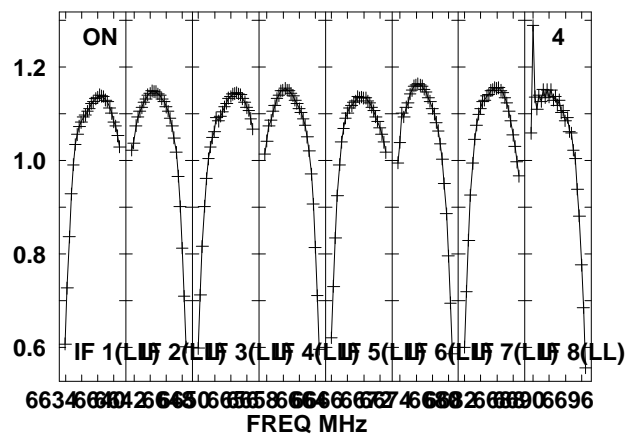
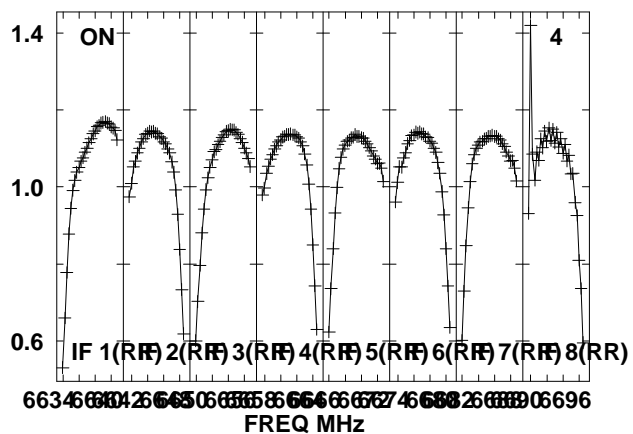
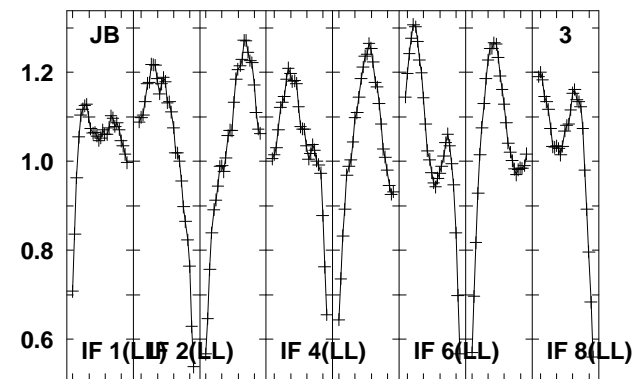
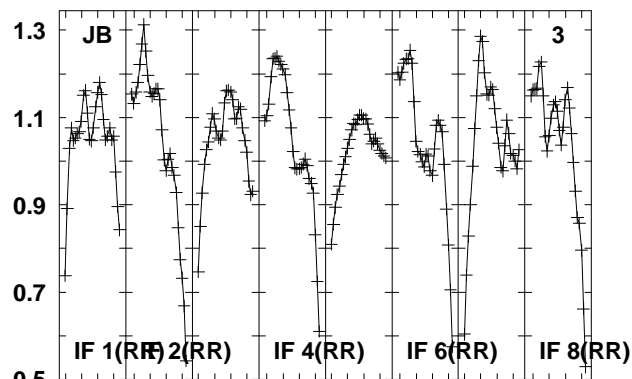
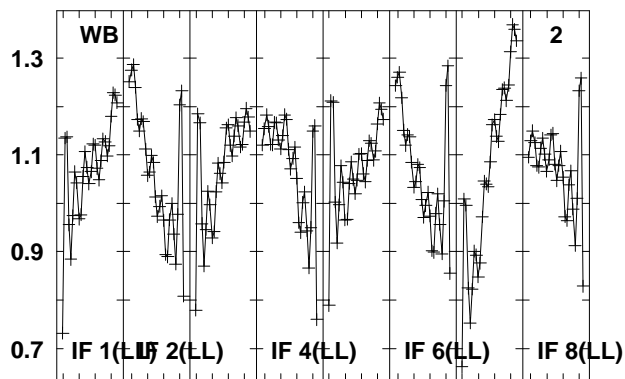
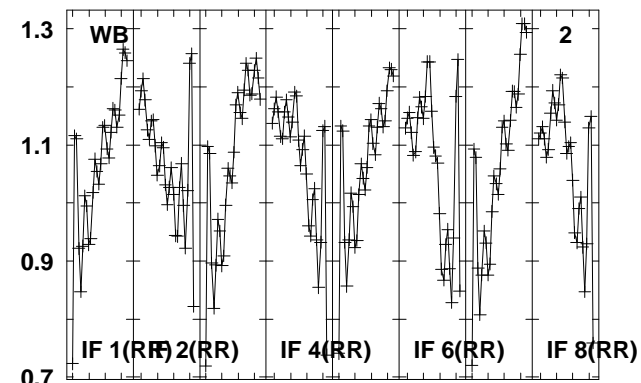
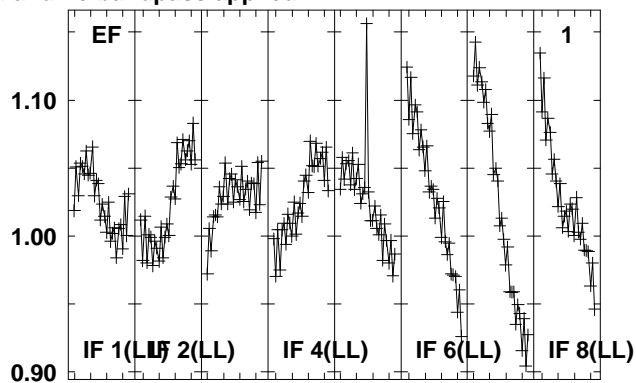
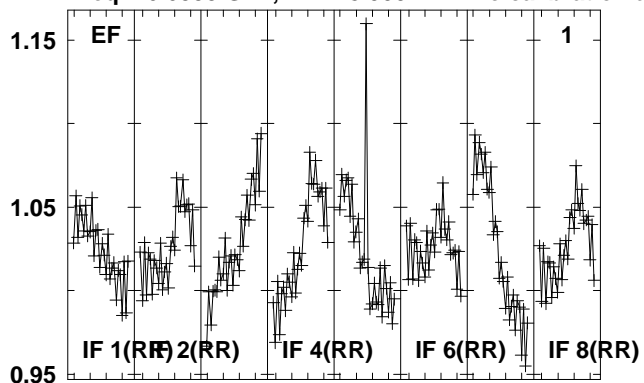

Lower frame: Real Jy
Total-power spectrum Antenna: *
Timerange: 00/15:51:42 to 00/15:52:39

Plot file version 236 created 15-MAR-2012 17:33:15

G85.40 EZ020E 2.UVDATA.1

Freq = 6.6335 GHz, Bw = 8.000 MH No calibration applied and no bandpass applied

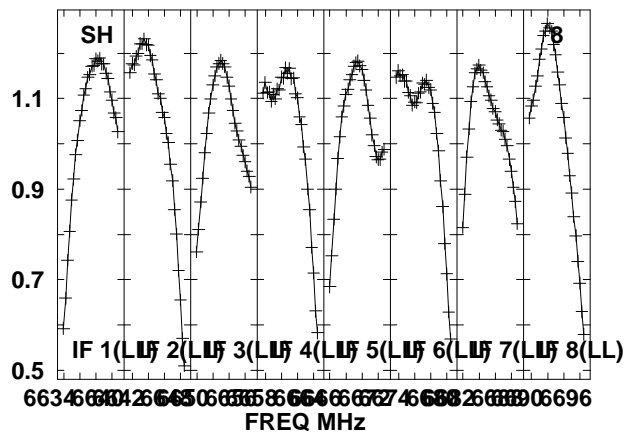
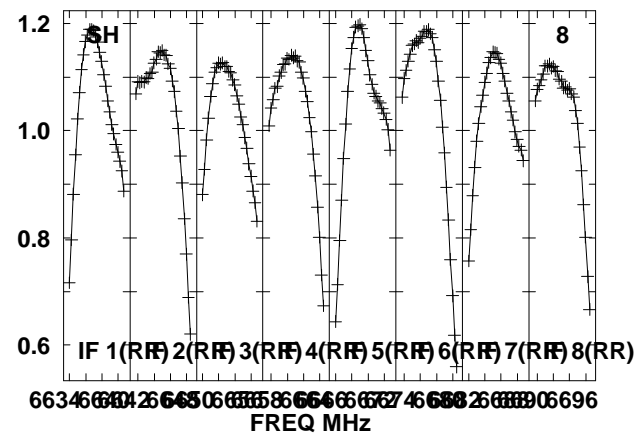
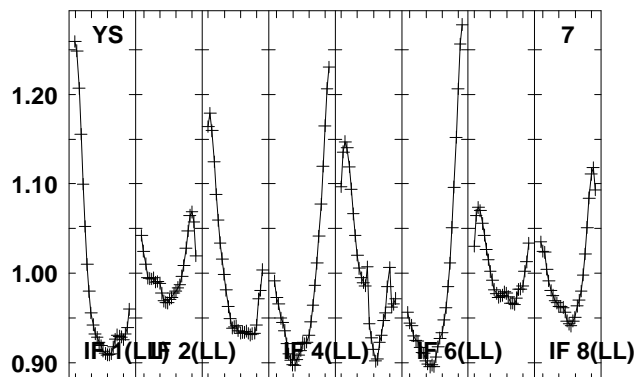
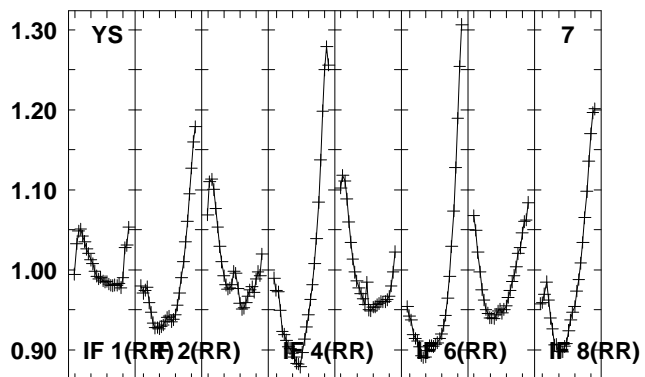
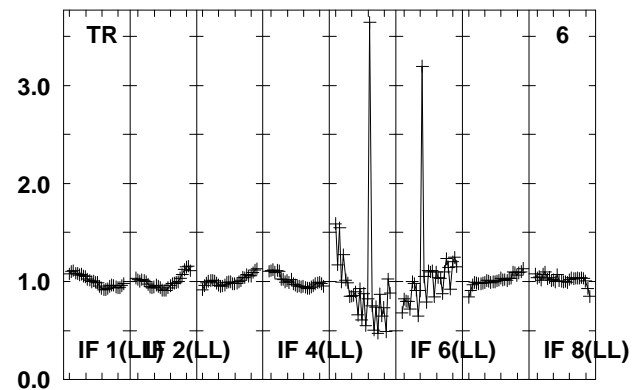
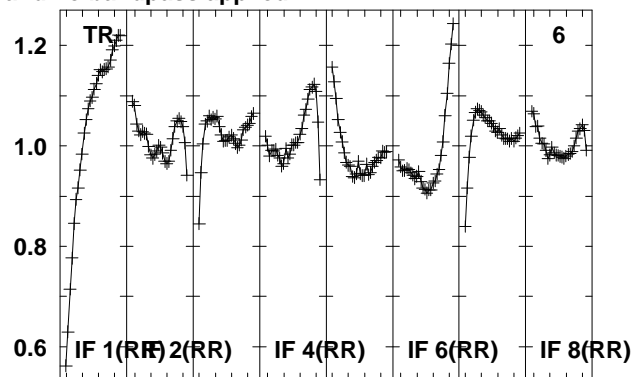
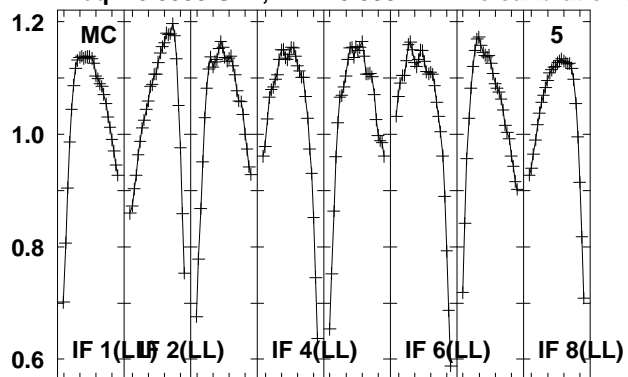

Lower frame: Real Jy
Total-power spectrum Antenna: *
Timerange: 00/15:51:42 to 00/15:52:39

Plot file version 237 created 15-MAR-2012 17:33:17

2114-G85 EZ020E 2.UVDATA.1

Freq = 6.6335 GHz, Bw = 8.000 MH No calibration applied and no bandpass applied

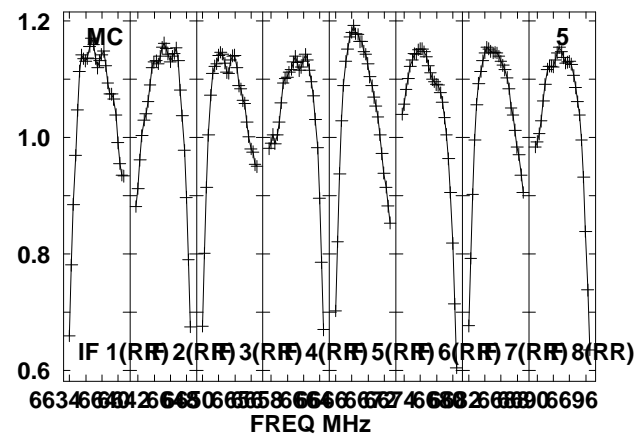
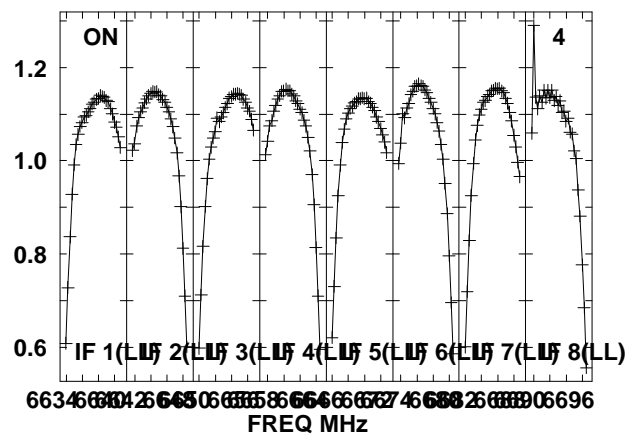
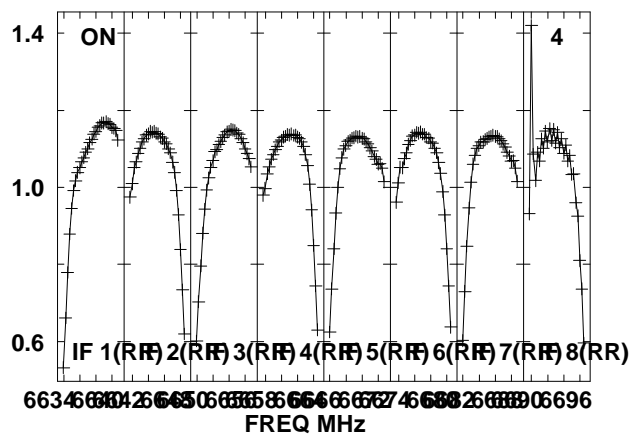
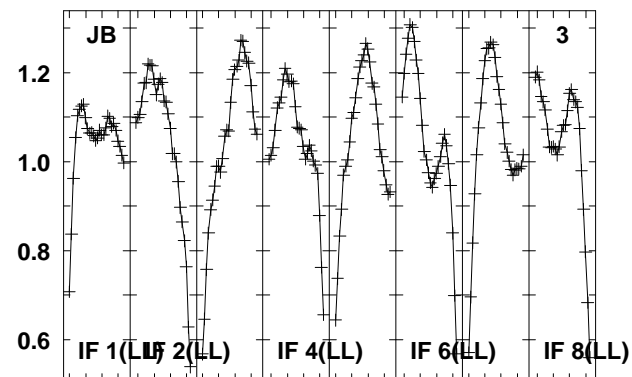
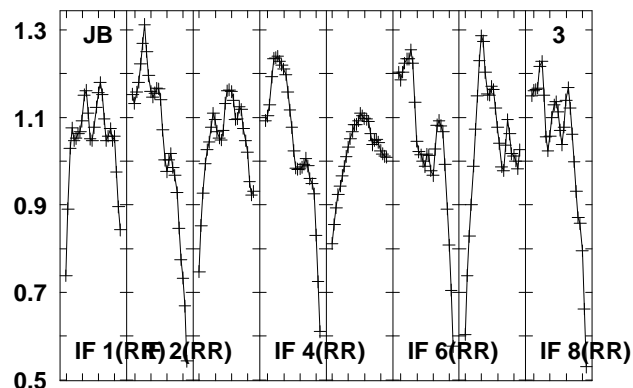
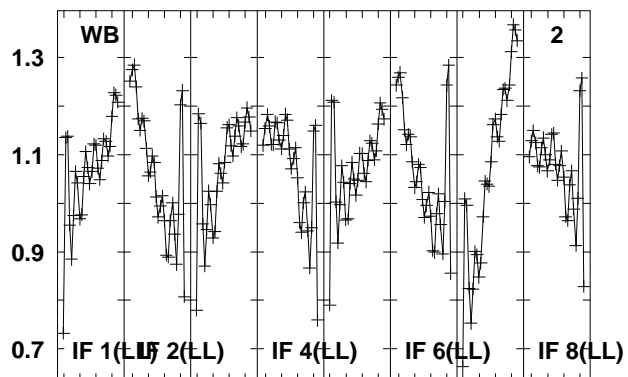
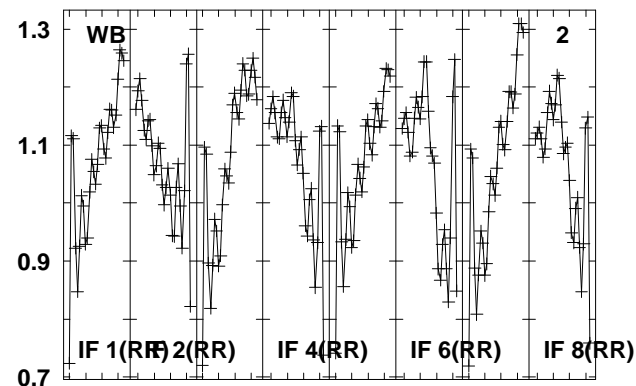
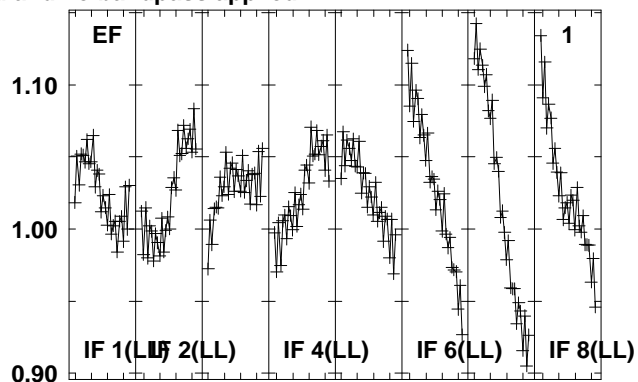
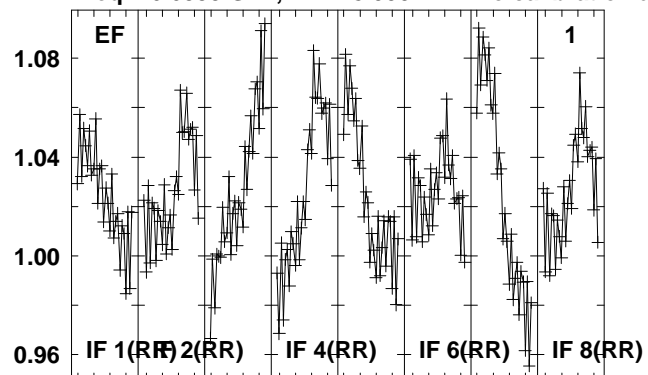

Lower frame: Real Jy
Total-power spectrum Antenna: *
Timerange: 00/15:52:41 to 00/15:54:09

Plot file version 238 created 15-MAR-2012 17:33:17

2114-G85 EZ020E 2.UVDATA.1

Freq = 6.6335 GHz, Bw = 8.000 MH No calibration applied and no bandpass applied

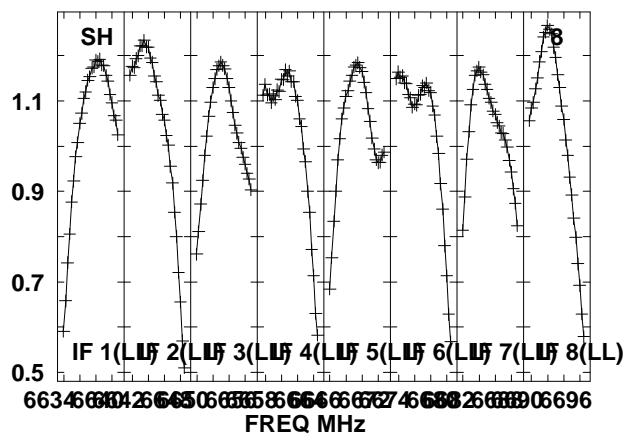
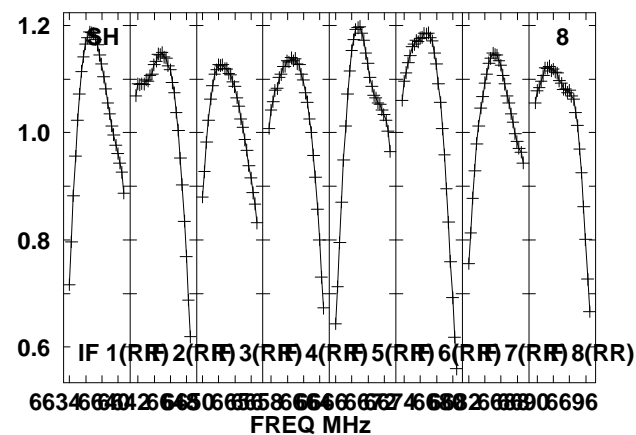
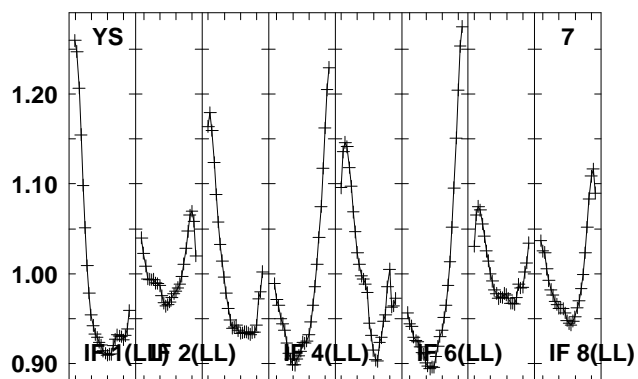
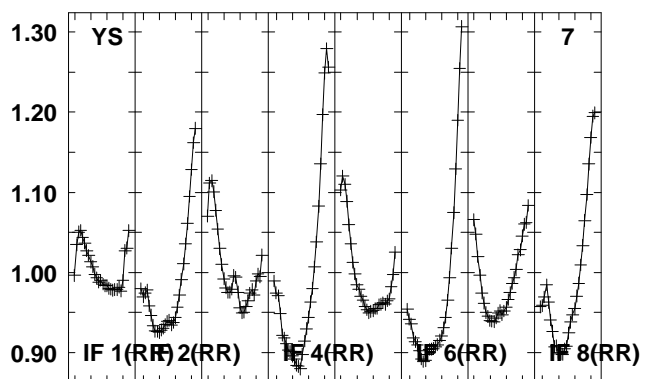
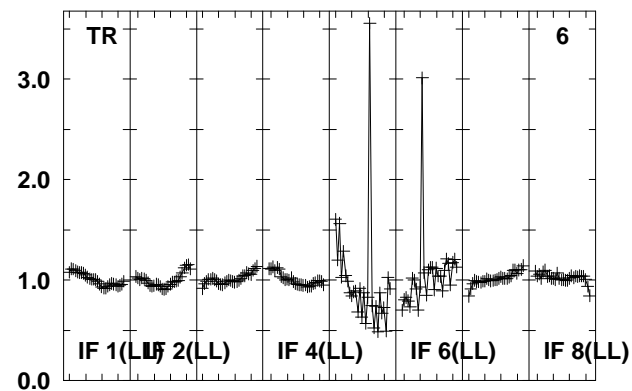
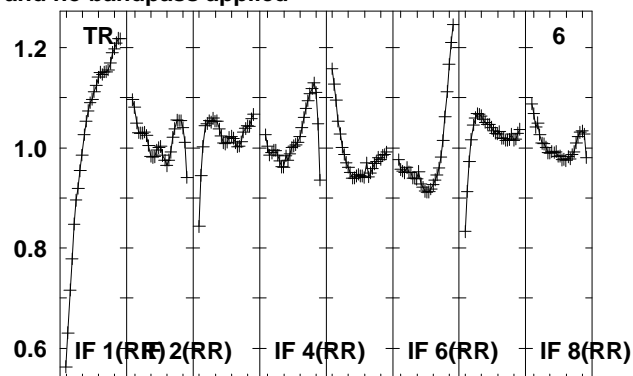
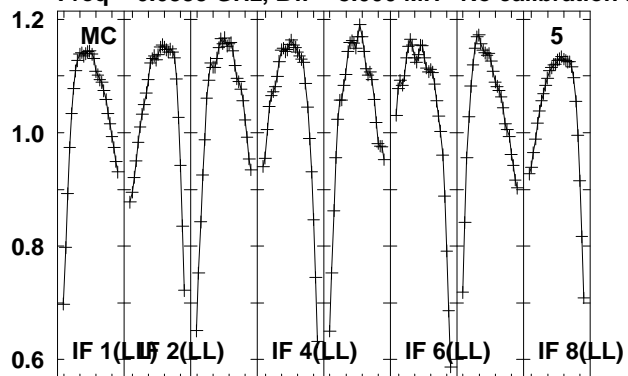

Lower frame: Real Jy

Total-power spectrum Antenna: *

Timerange: 00/15:52:41 to 00/15:54:09

Plot file version 239 created 15-MAR-2012 17:33:18

G85.40 EZ020E 2.UVDATA.1

Freq = 6.6335 GHz, Bw = 8.000 MH No calibration applied and no bandpass applied

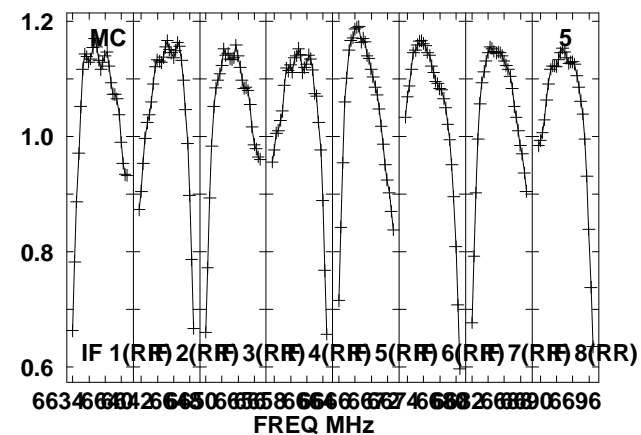
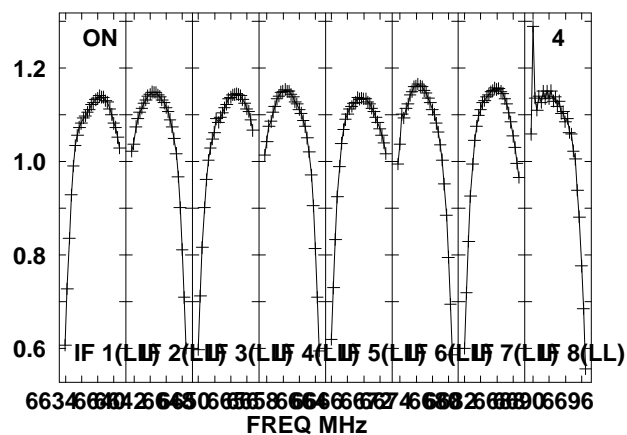
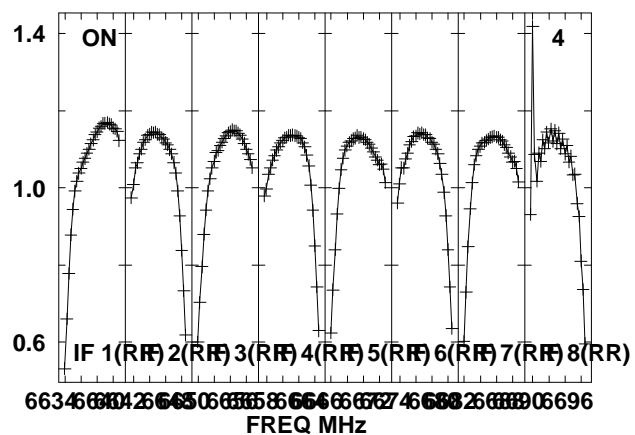
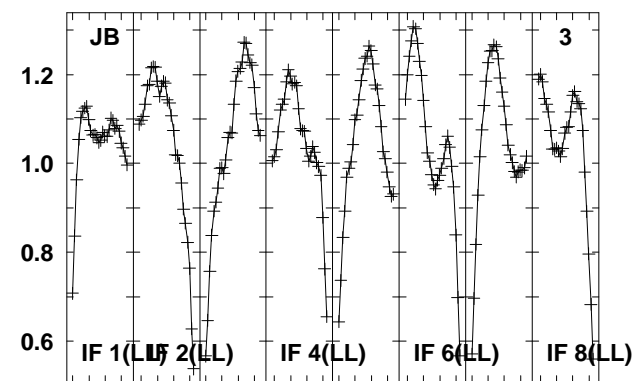
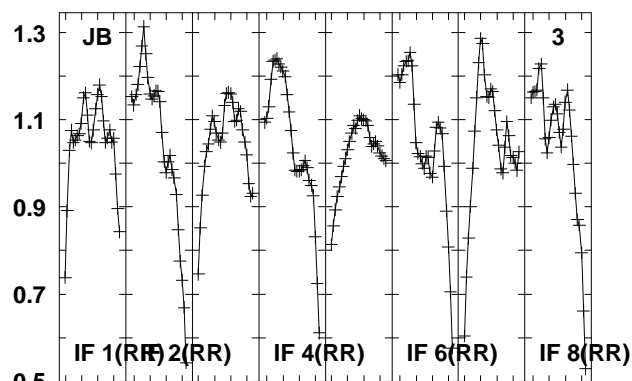
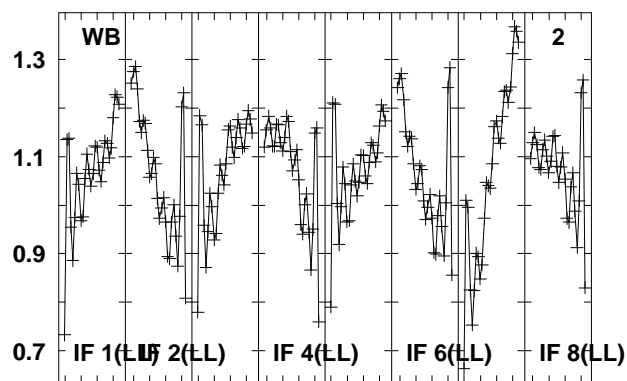
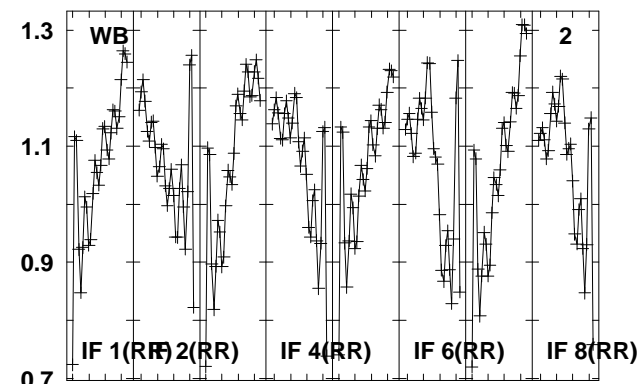
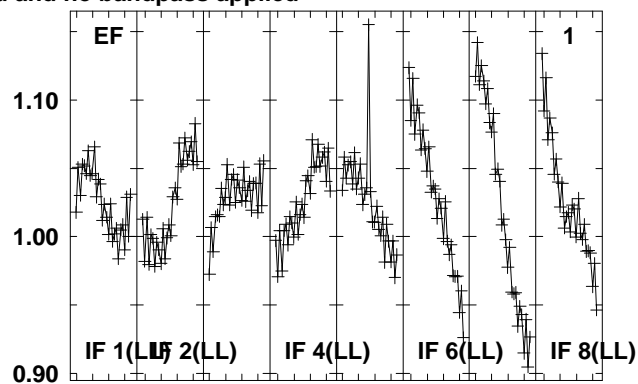
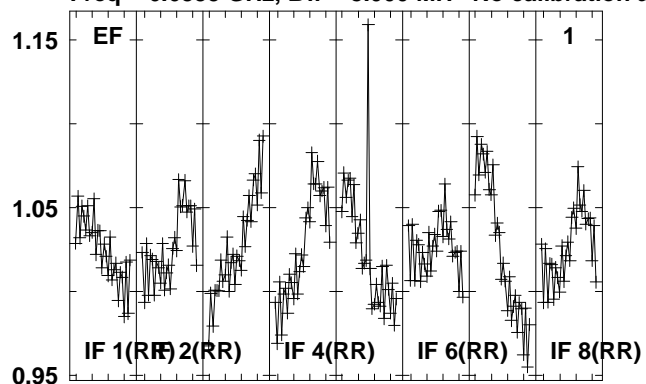

Lower frame: Real Jy
Total-power spectrum Antenna: *
Timerange: 00/15:54:12 to 00/15:55:40

Plot file version 240 created 15-MAR-2012 17:33:18
G85.40 EZ020E 2.UVDATA.1
Freq = 6.6335 GHz, Bw = 8.000 MH No calibration applied and no bandpass applied

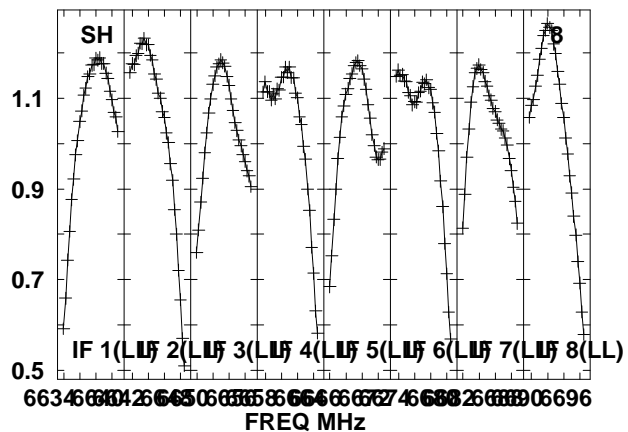
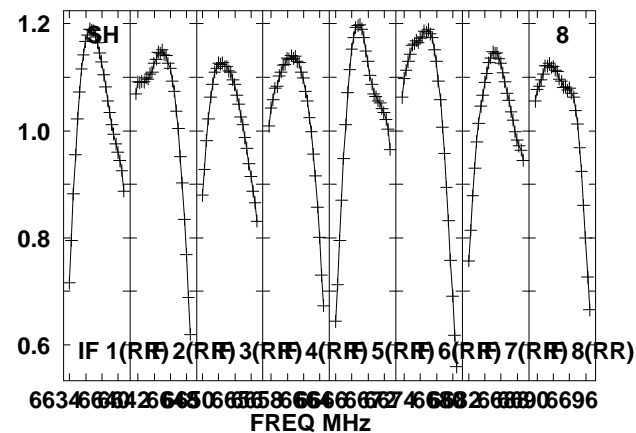
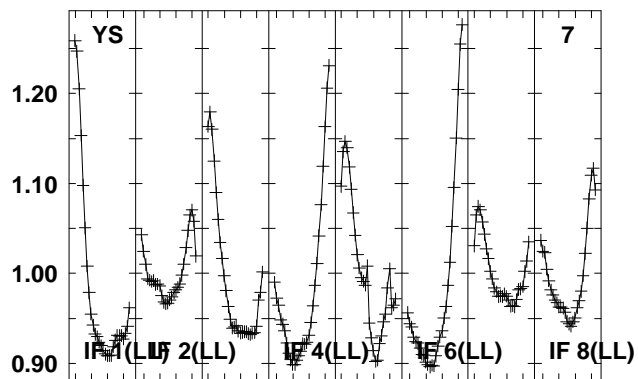
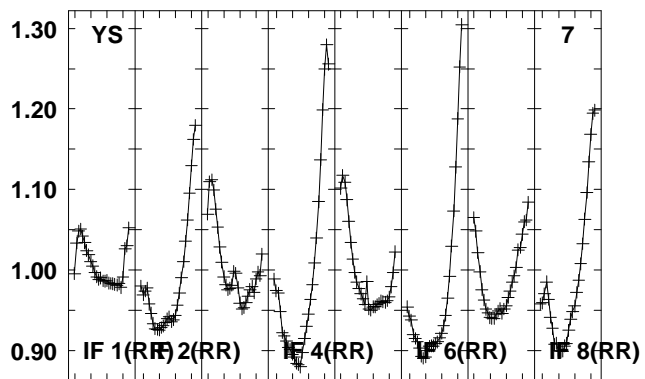
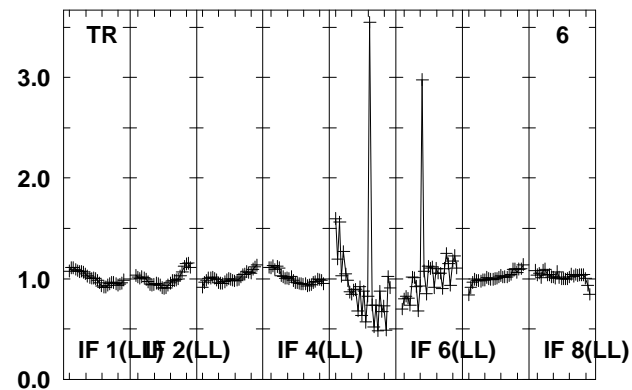
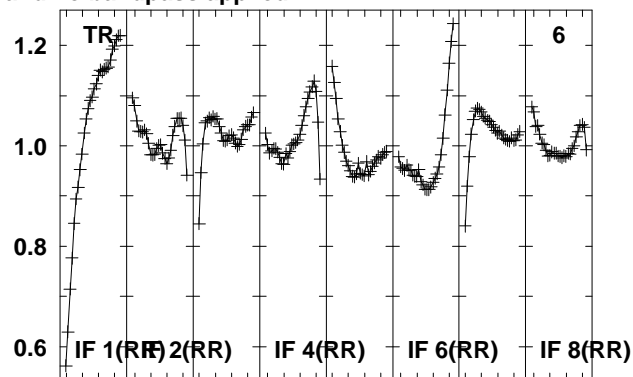
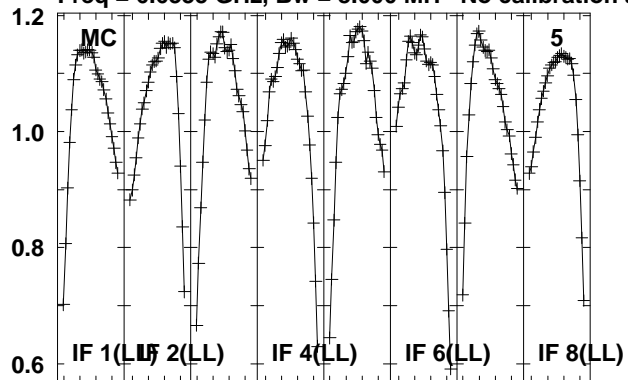

Lower frame: Real Jy
Total-power spectrum Antenna: *
Timerange: 00/15:54:12 to 00/15:55:40

Plot file version 241 created 15-MAR-2012 17:33:19

2102-G85 EZ020E 2.UVDATA.1

Freq = 6.6335 GHz, Bw = 8.000 MH No calibration applied and no bandpass applied

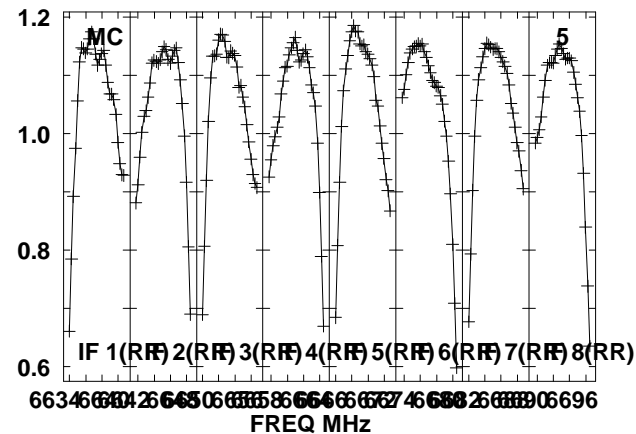
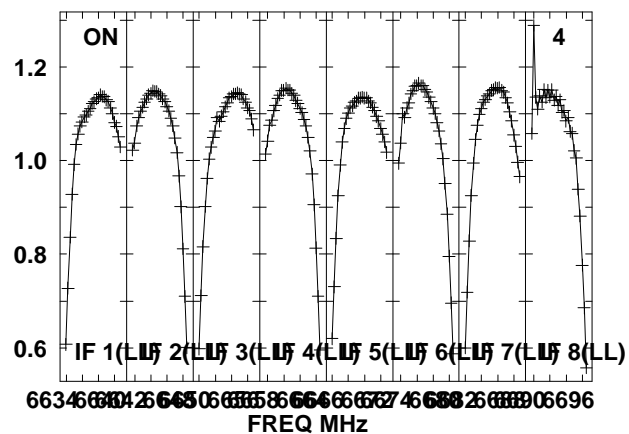
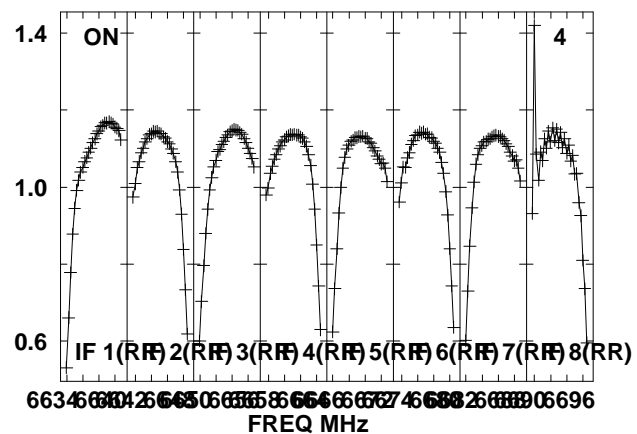
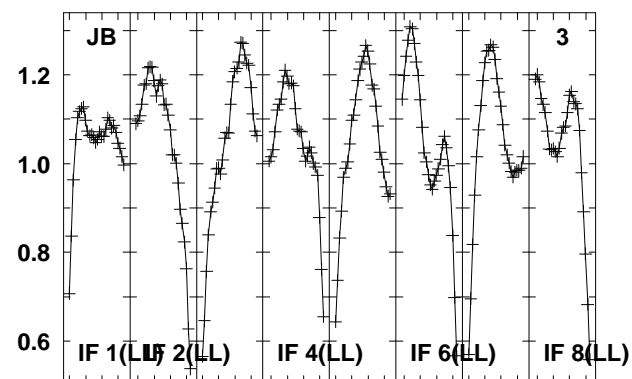
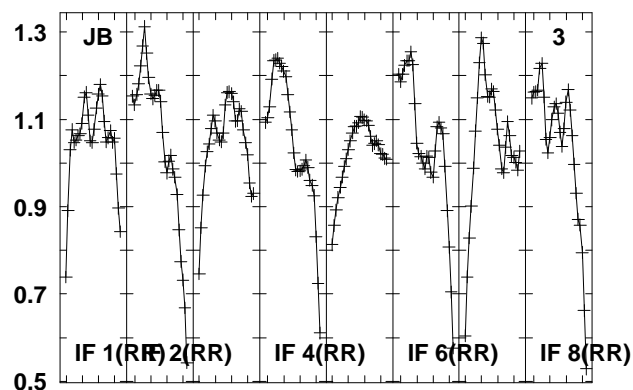
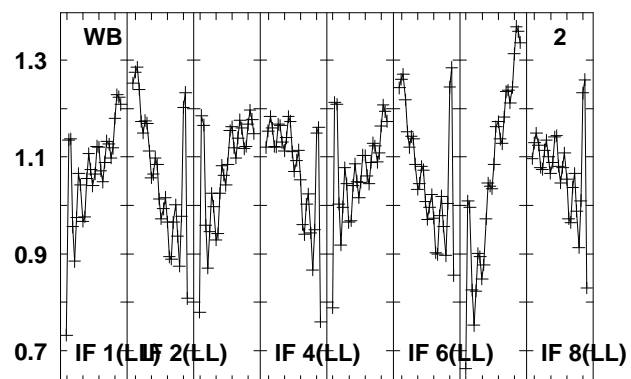
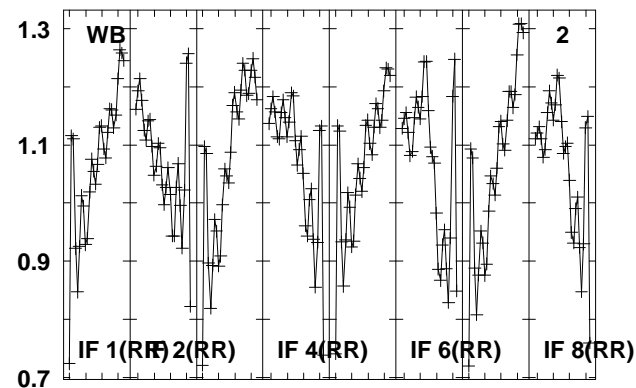
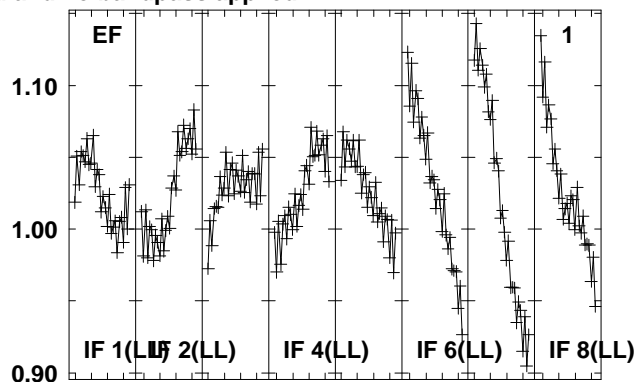
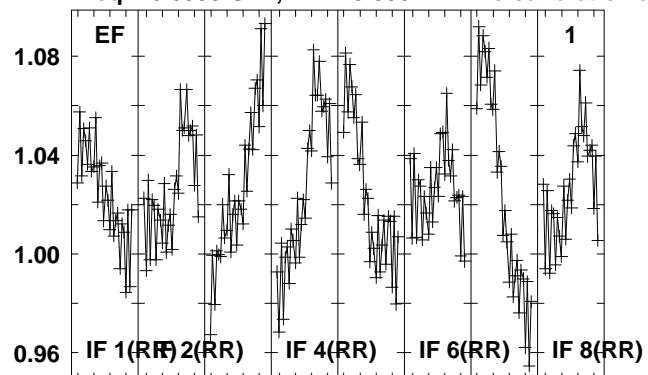

Lower frame: Real Jy

Total-power spectrum Antenna: *

Timerange: 00/15:55:42 to 00/15:57:10

Plot file version 242 created 15-MAR-2012 17:33:20

2102-G85 EZ20E 2.UVDATA.1

Freq = 6.6335 GHz, Bw = 8.000 MH No calibration applied and no bandpass applied

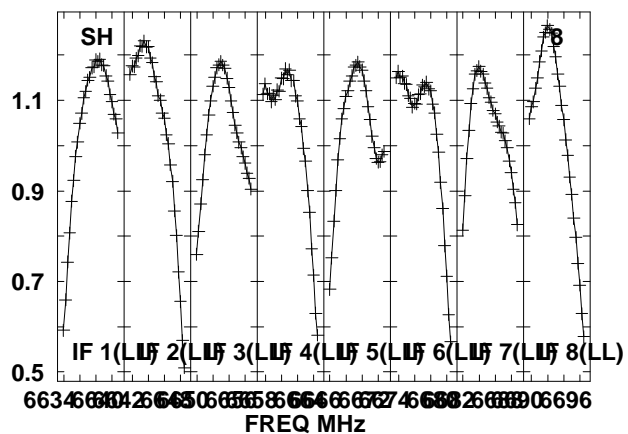
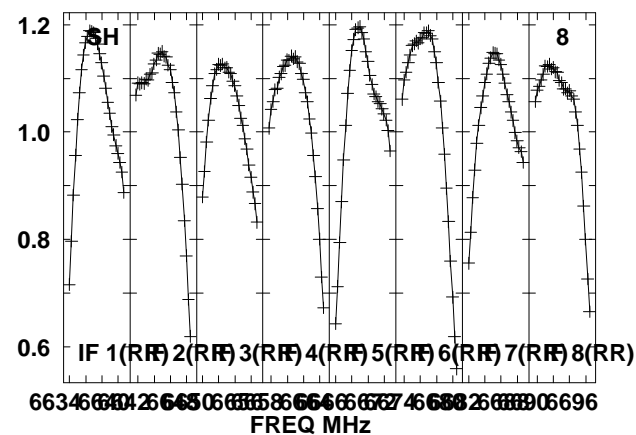
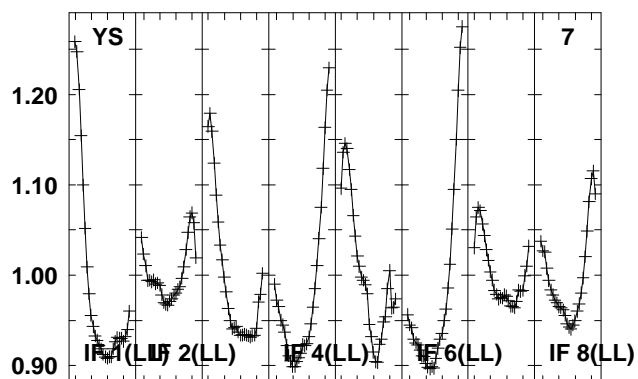
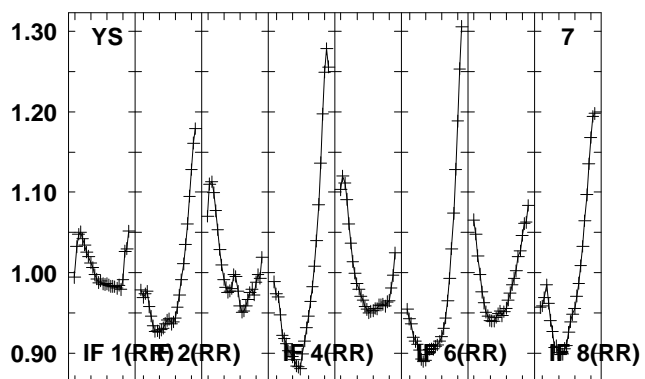
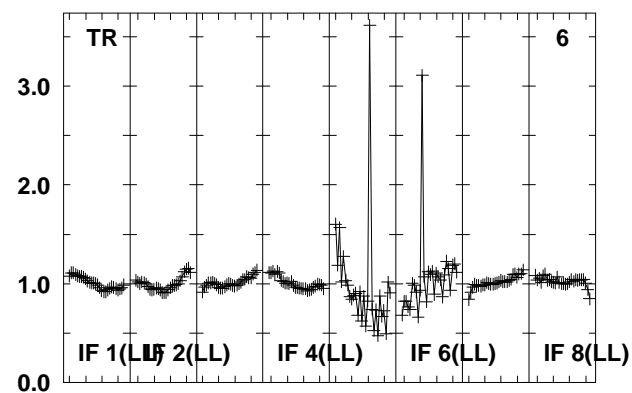
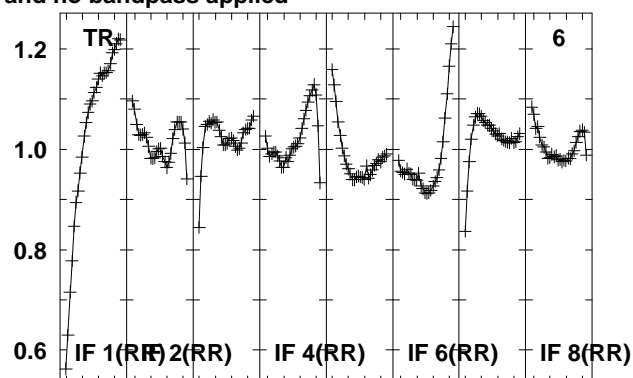
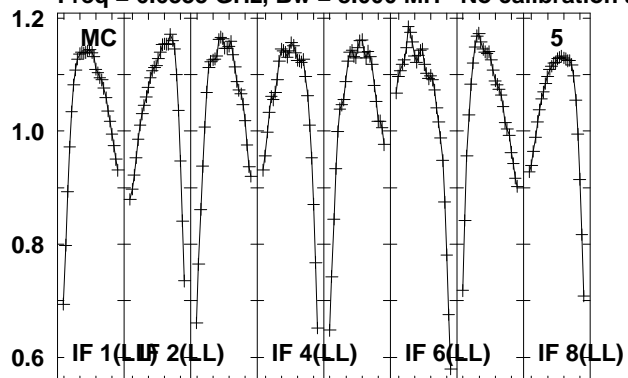

Lower frame: Real Jy

Total-power spectrum Antenna: *

Timerange: 00/15:55:42 to 00/15:57:10

Plot file version 243 created 15-MAR-2012 17:33:21

G85.40 EZ020E 2.UVDATA.1

Freq = 6.6335 GHz, Bw = 8.000 MH No calibration applied and no bandpass applied

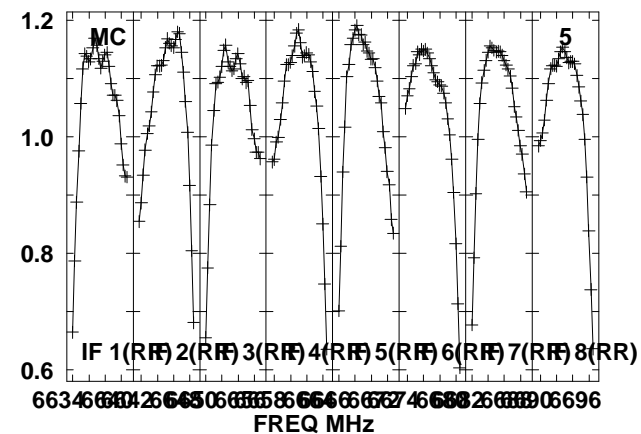
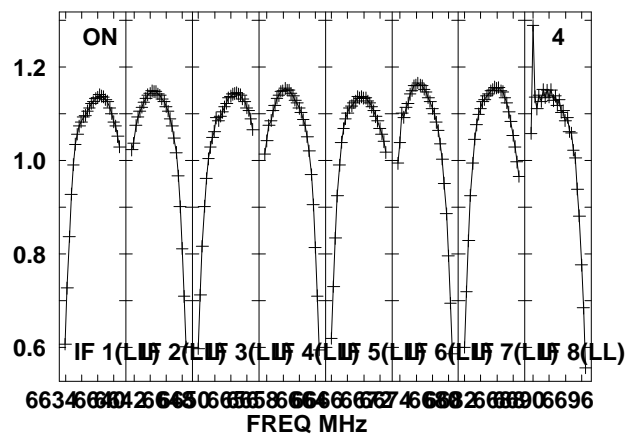
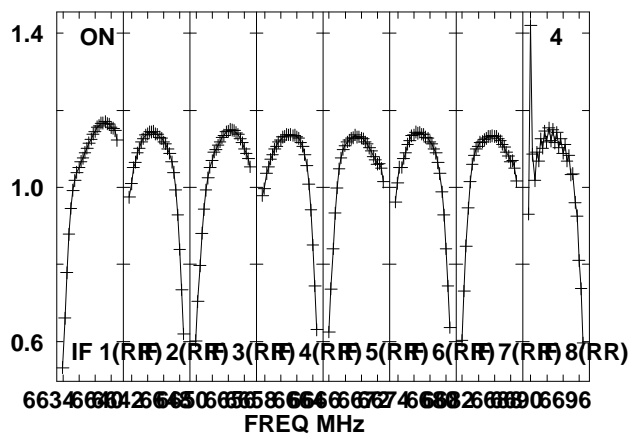
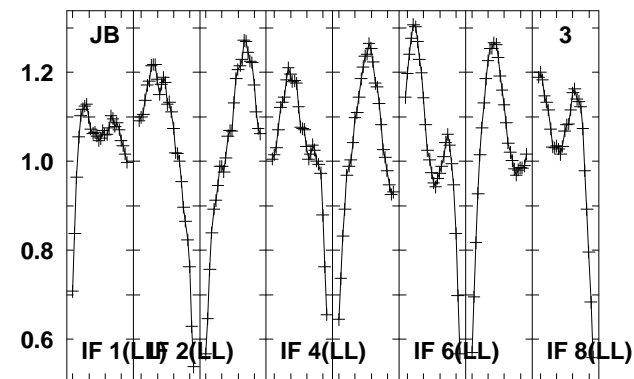
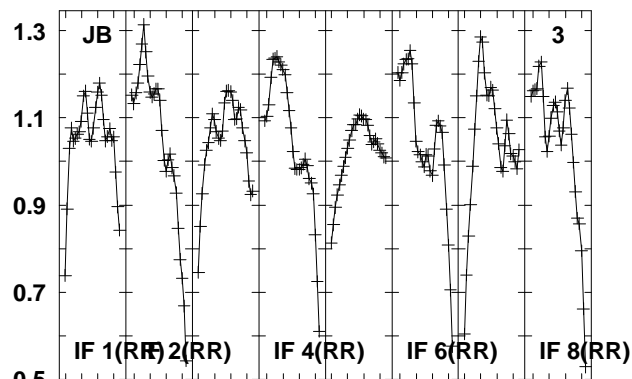
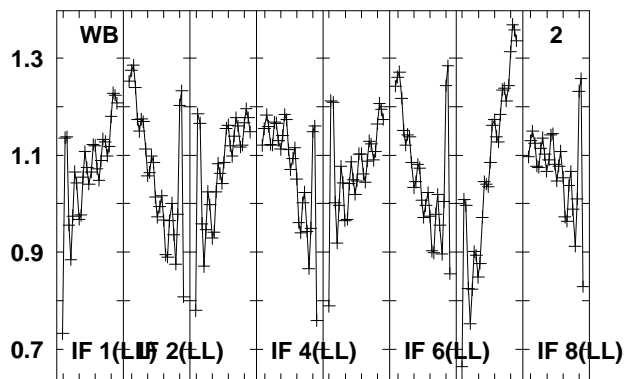
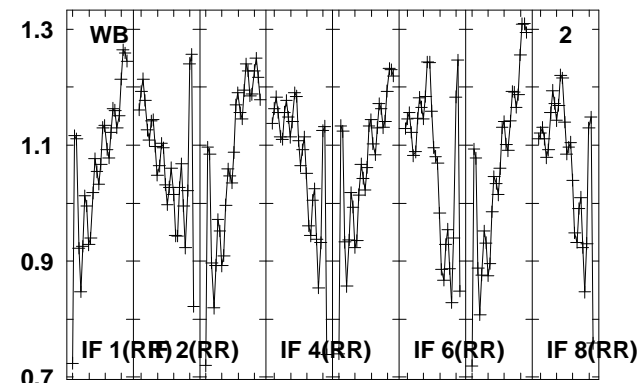
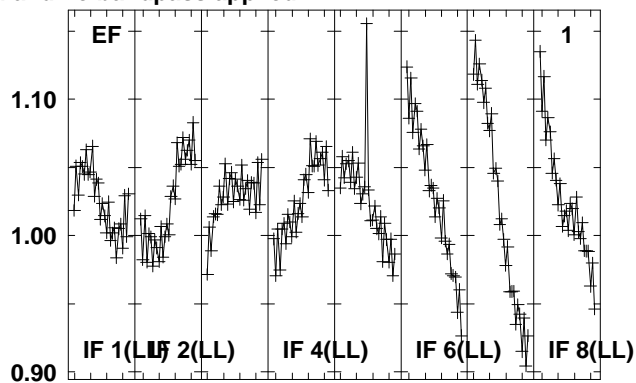
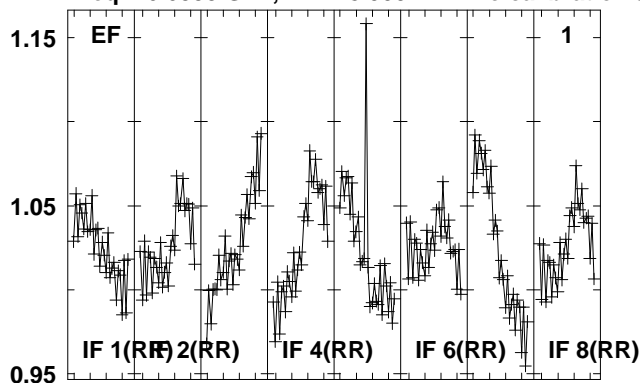

Lower frame: Real Jy
Total-power spectrum Antenna: *
Timerange: 00:15:57:11 to 00:15:58:39

Plot file version 244 created 15-MAR-2012 17:33:21

G85.40 EZ020E 2.UVDATA.1

Freq = 6.6335 GHz, Bw = 8.000 MH No calibration applied and no bandpass applied

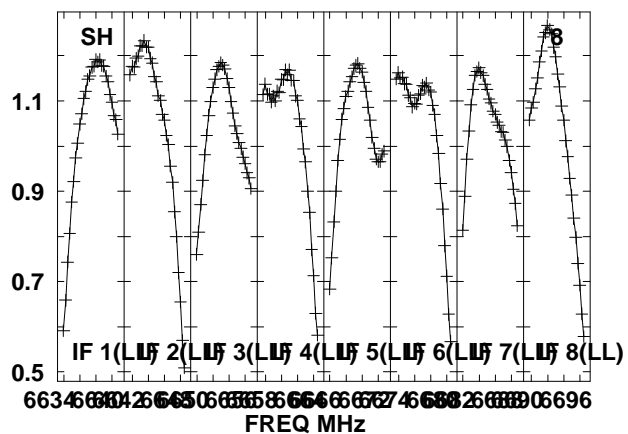
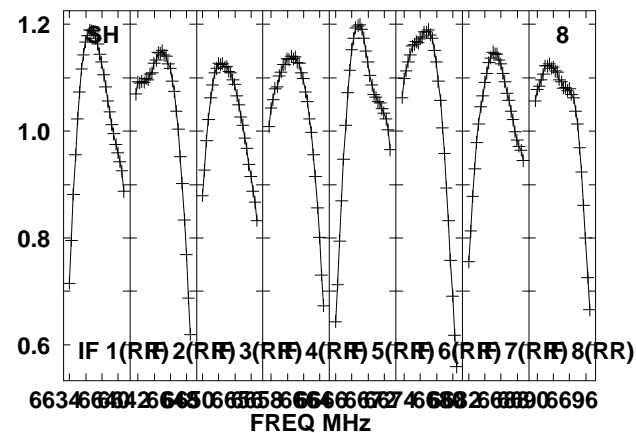
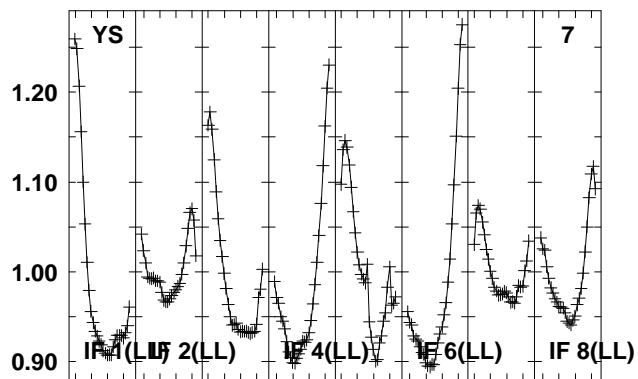
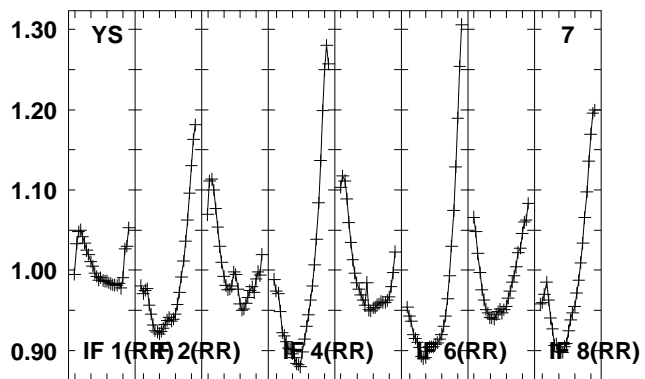
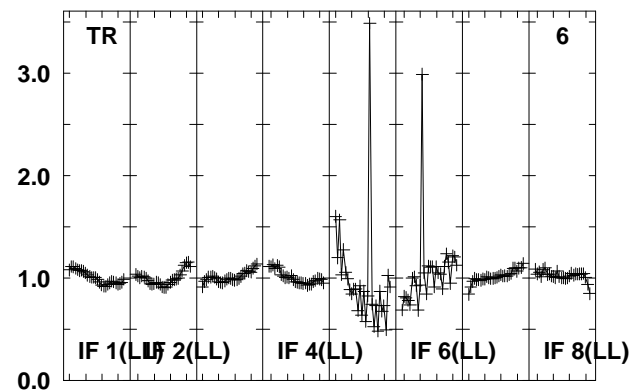
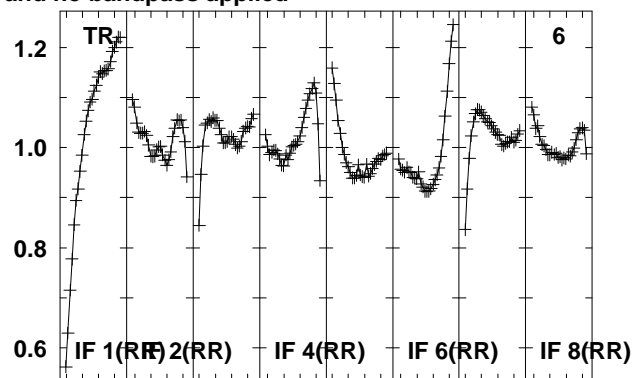
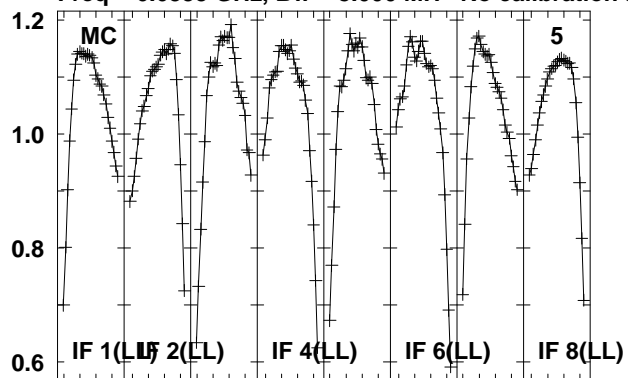

Lower frame: Real Jy

Total-power spectrum Antenna: *

Timerange: 00/15:57:11 to 00/15:58:39

Plot file version 245 created 15-MAR-2012 17:33:23

2114-G85 EZ020E 2.UVDATA.1

Freq = 6.6335 GHz, Bw = 8.000 MH No calibration applied and no bandpass applied

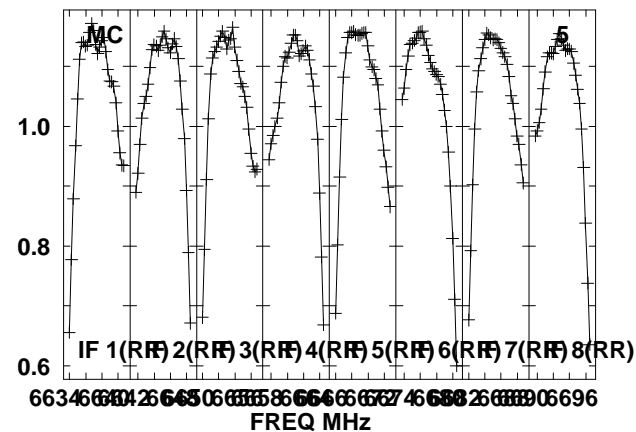
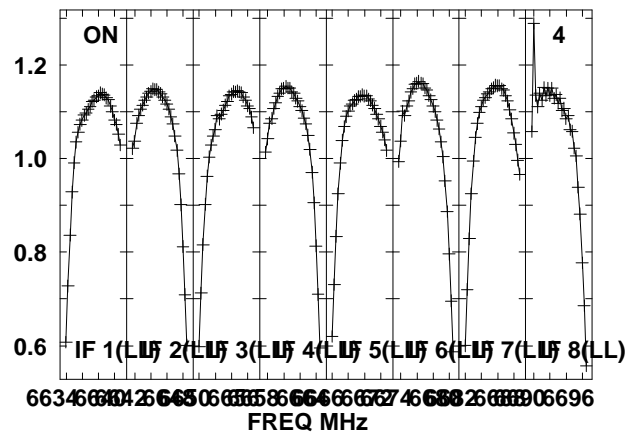
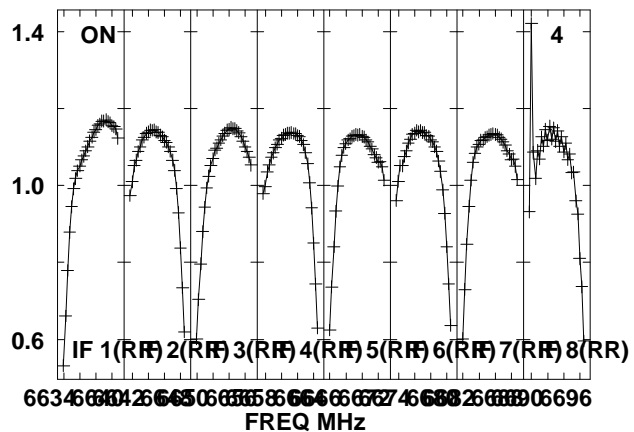
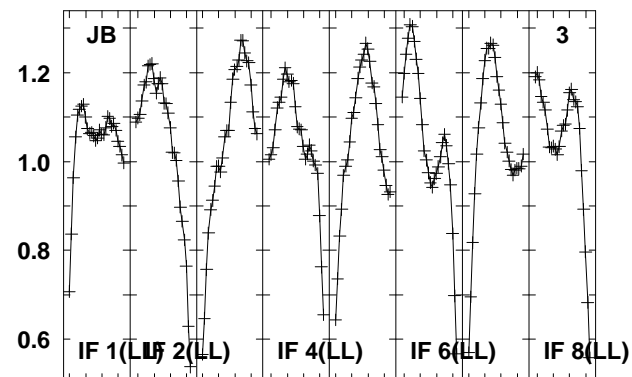
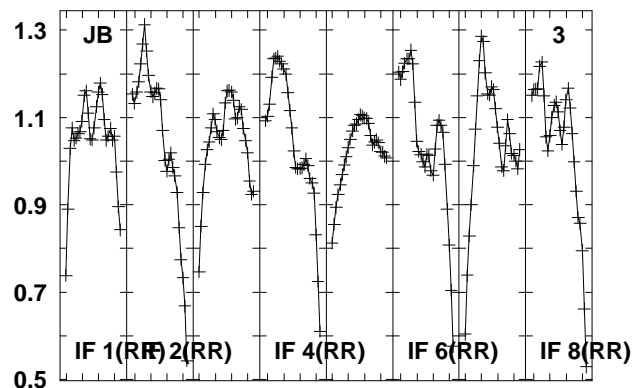
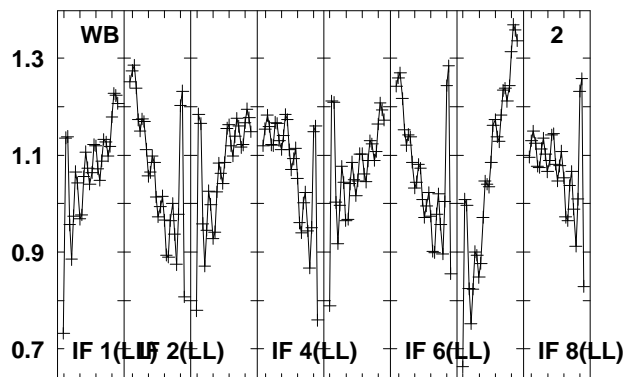
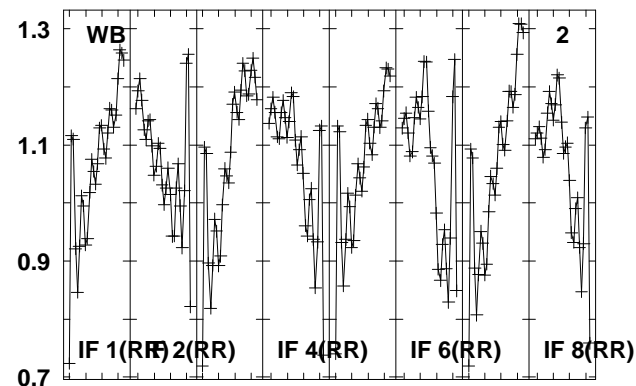
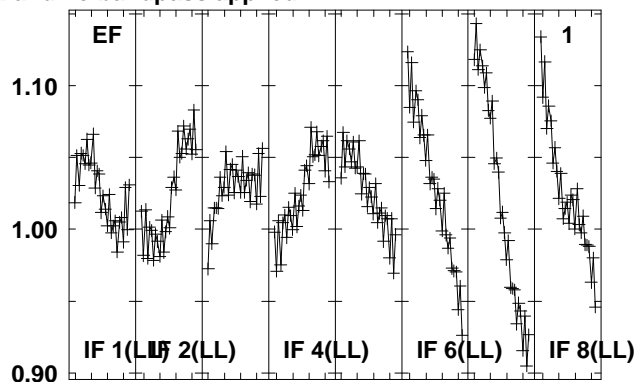
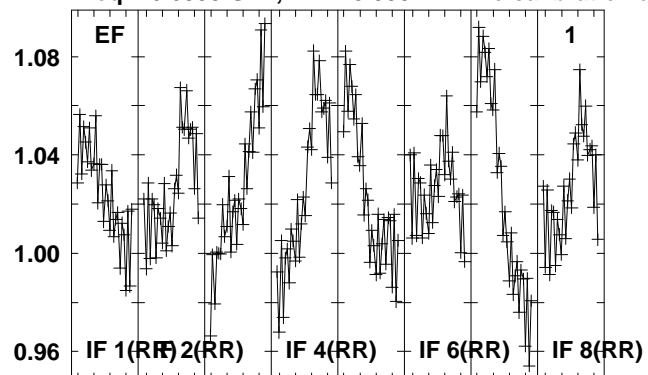

Lower frame: Real Jy
Total-power spectrum Antenna: *
Timerange: 00/15:58:41 to 00/16:00:09

Plot file version 246 created 15-MAR-2012 17:33:24

2114-G85 EZ020E 2.UVDATA.1

Freq = 6.6335 GHz, Bw = 8.000 MH No calibration applied and no bandpass applied

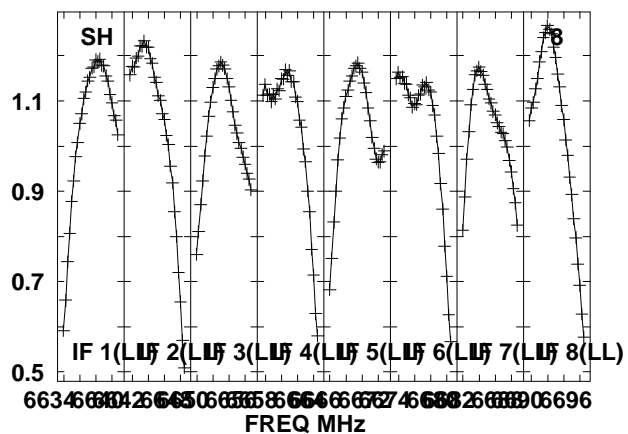
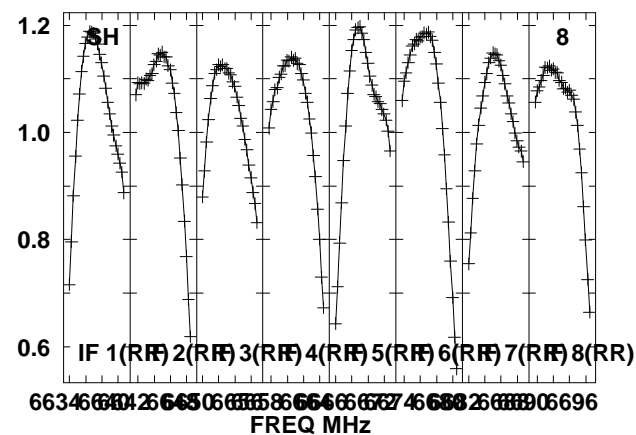
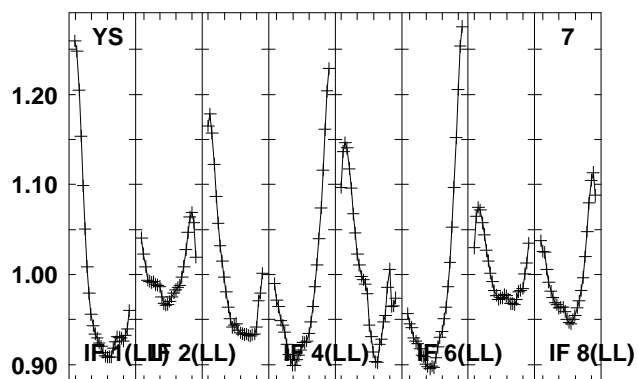
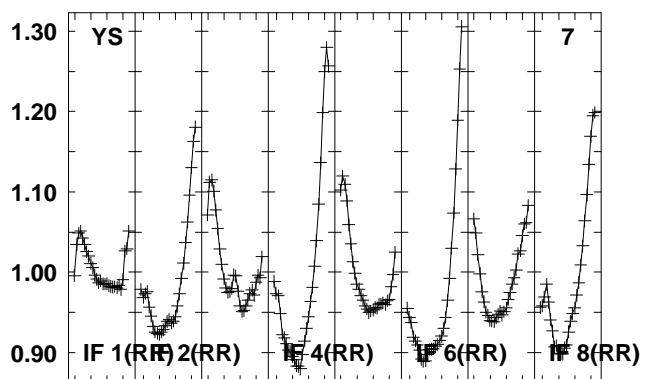
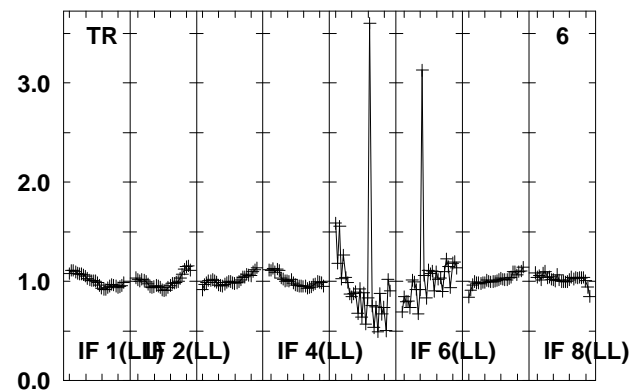
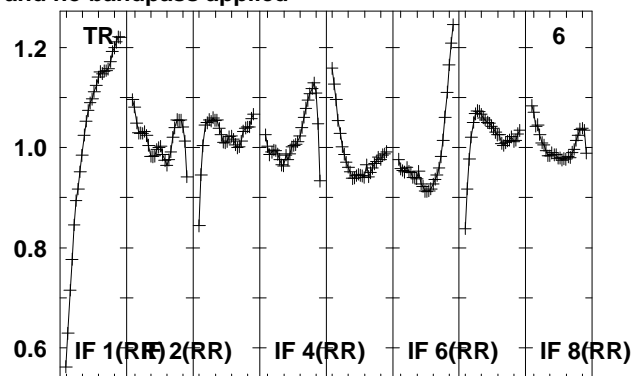
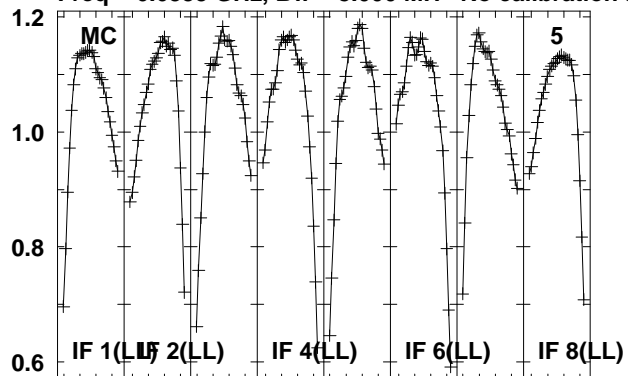

Lower frame: Real Jy
Total-power spectrum Antenna: *
Timerange: 00/15:58:41 to 00/16:00:09

Plot file version 247 created 15-MAR-2012 17:33:25

G85.40 EZ020E 2.UVDATA.1

Freq = 6.6335 GHz, Bw = 8.000 MH No calibration applied and no bandpass applied

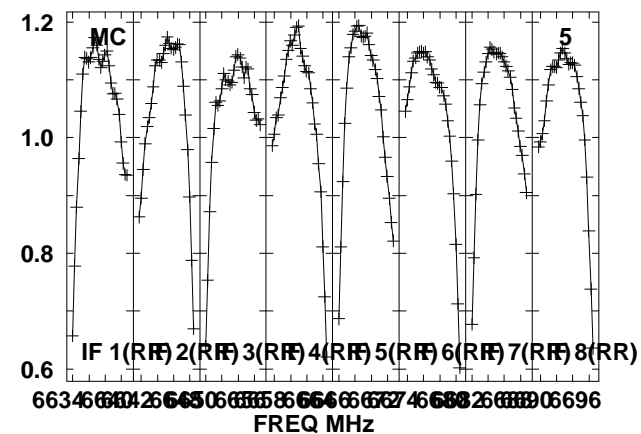
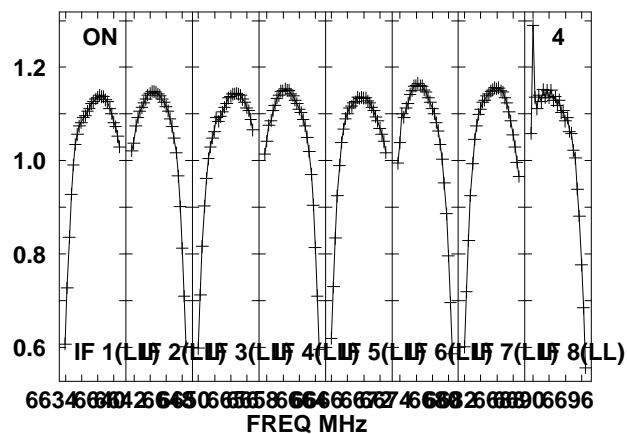
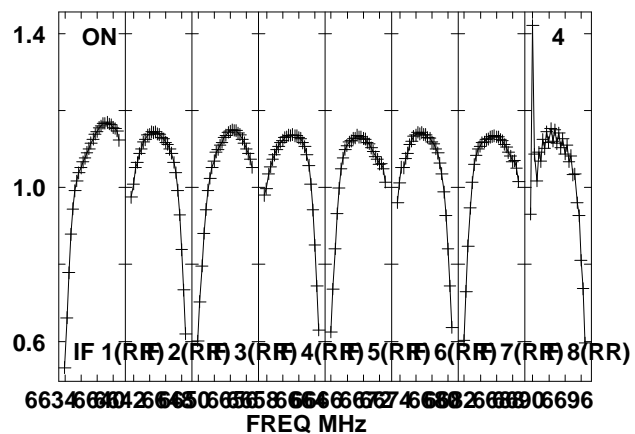
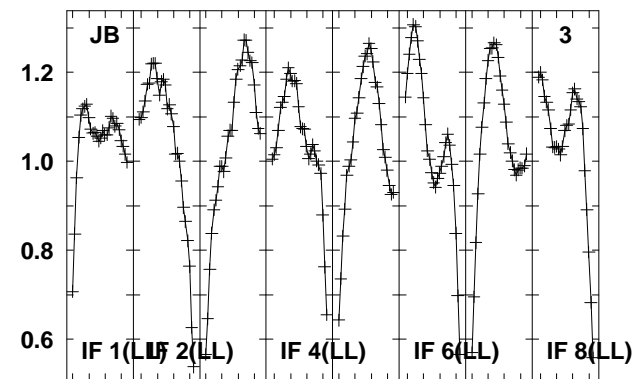
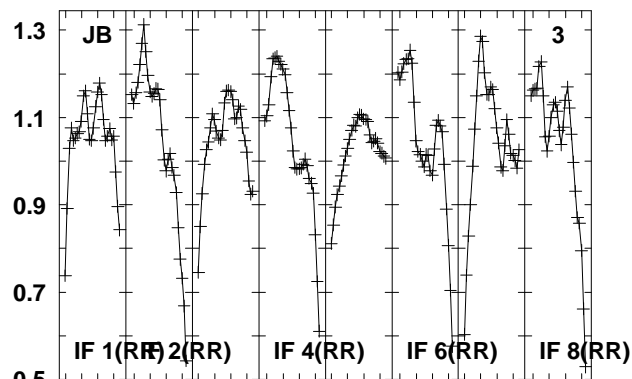
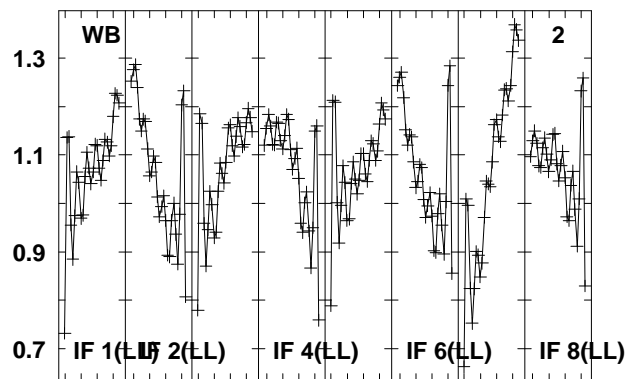
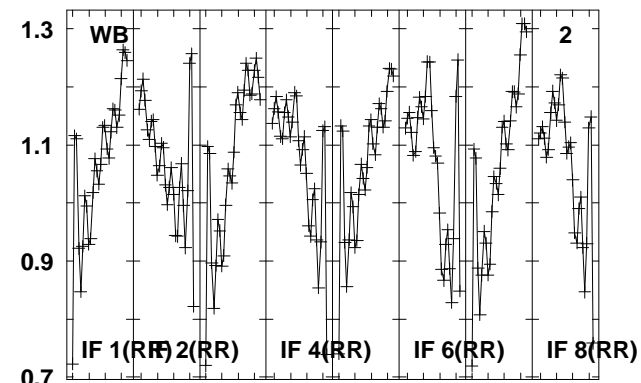
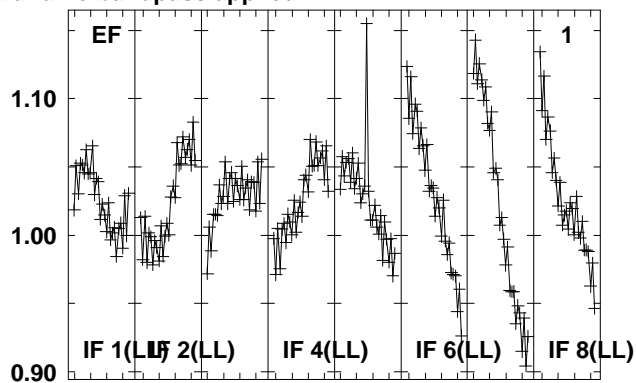
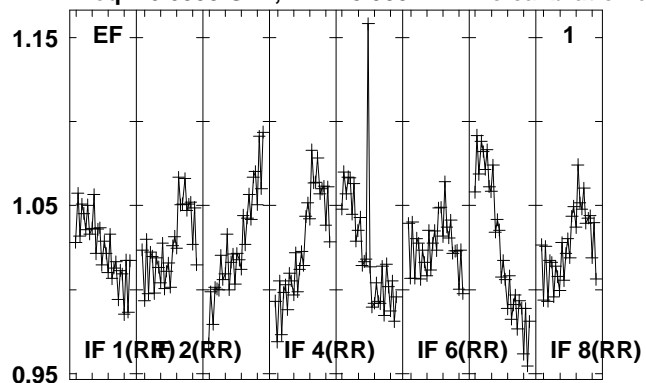

Lower frame: Real Jy
Total-power spectrum Antenna: *
Timerange: 00/16:00:12 to 00/16:01:40

Plot file version 248 created 15-MAR-2012 17:33:25

G85.40 EZ020E 2.UVDATA.1

Freq = 6.6335 GHz, Bw = 8.000 MH No calibration applied and no bandpass applied

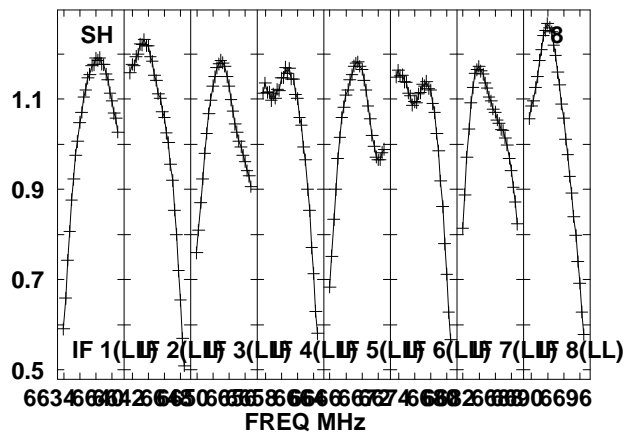
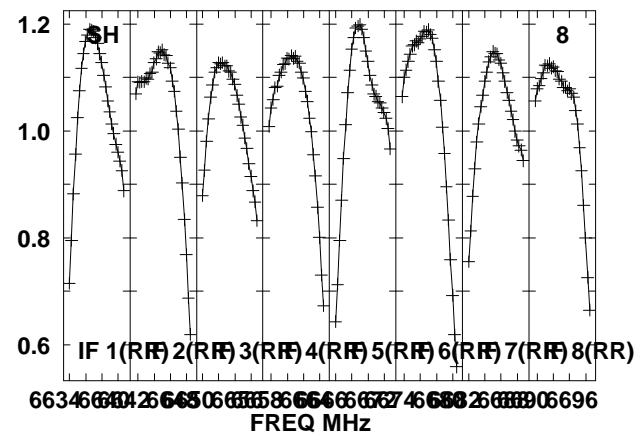
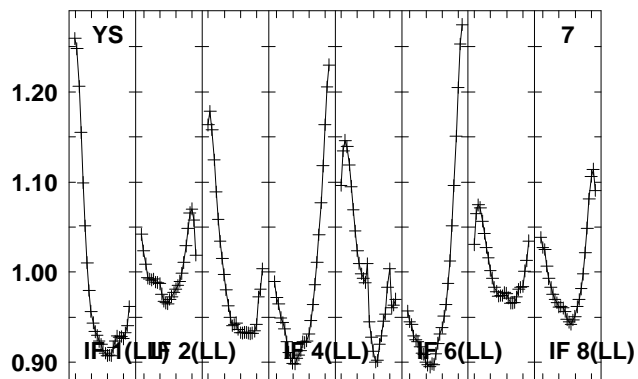
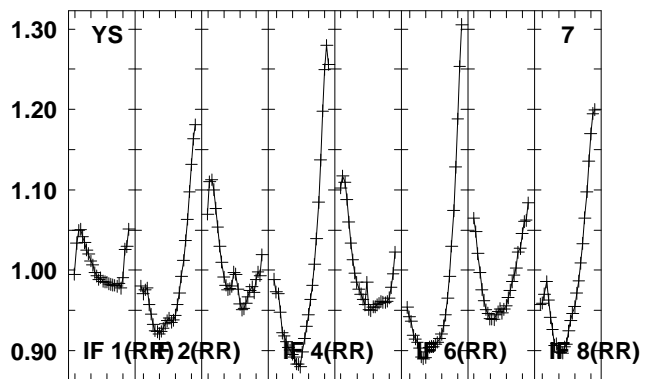
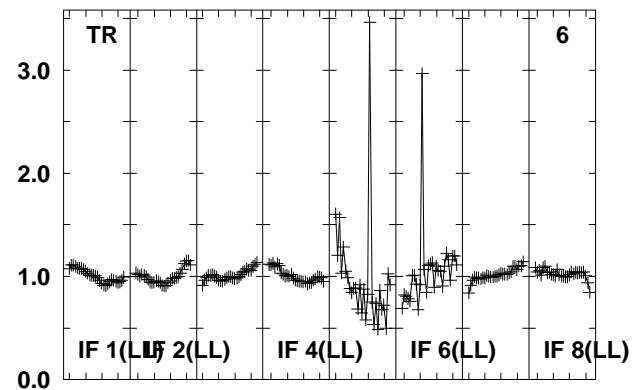
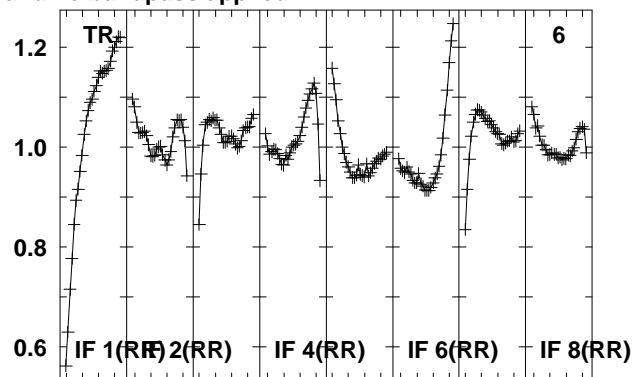
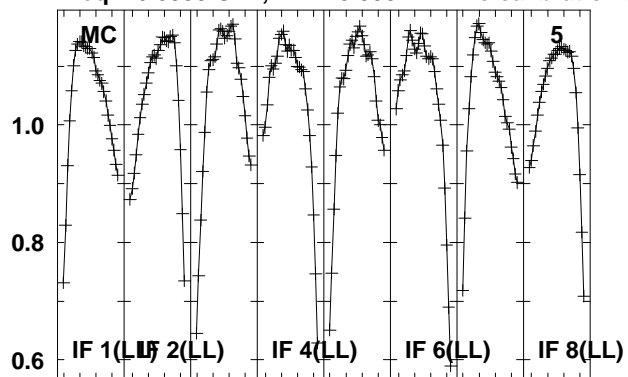

Lower frame: Real Jy
Total-power spectrum Antenna: *
Timerange: 00/16:00:12 to 00/16:01:40

Plot file version 249 created 15-MAR-2012 17:33:26

2102-G85 EZ020E 2.UVDATA.1

Freq = 6.6335 GHz, Bw = 8.000 MH No calibration applied and no bandpass applied

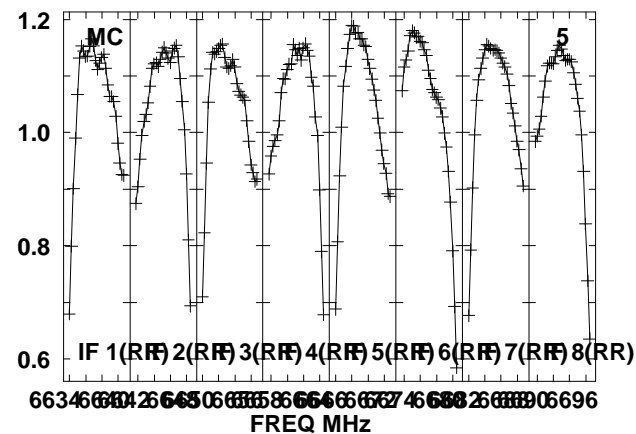
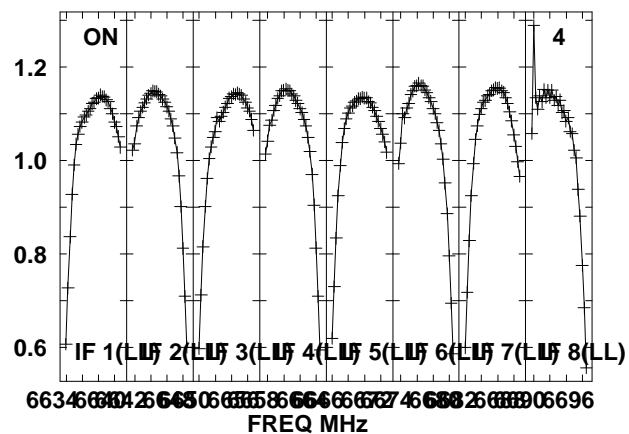
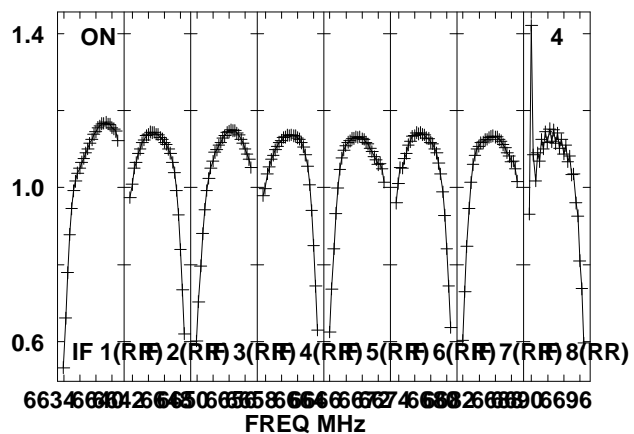
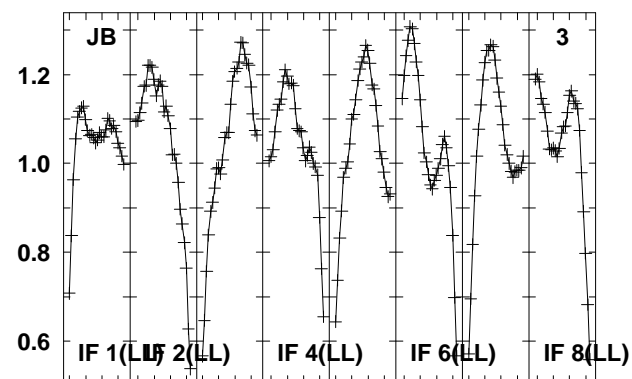
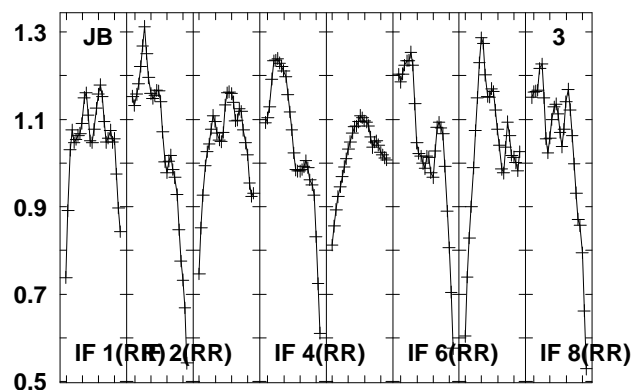
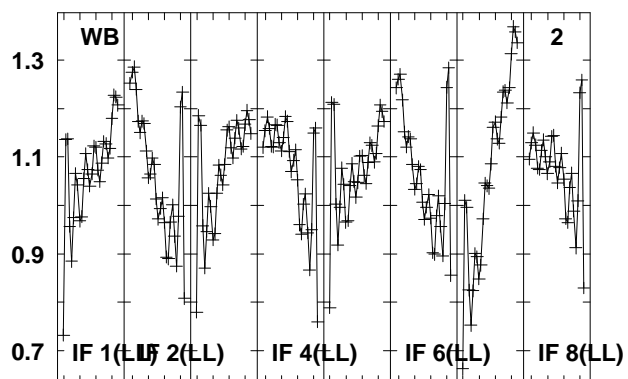
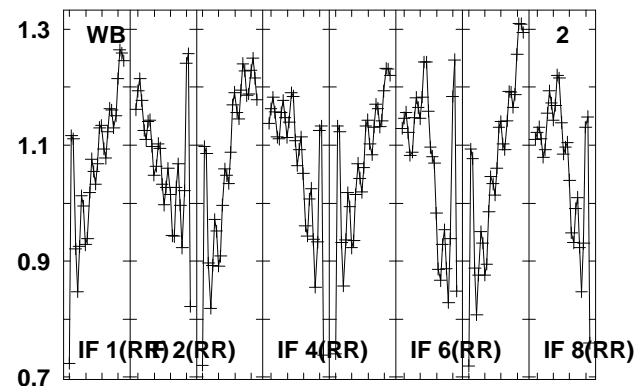
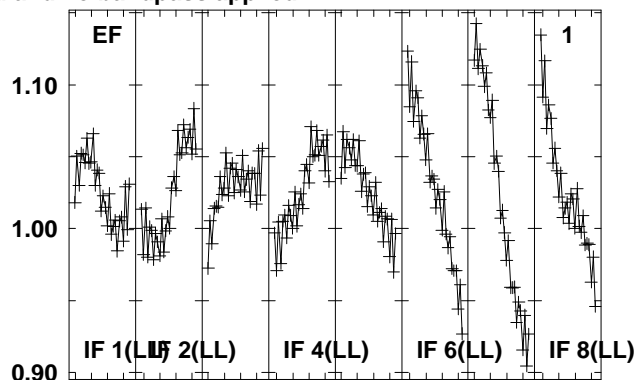
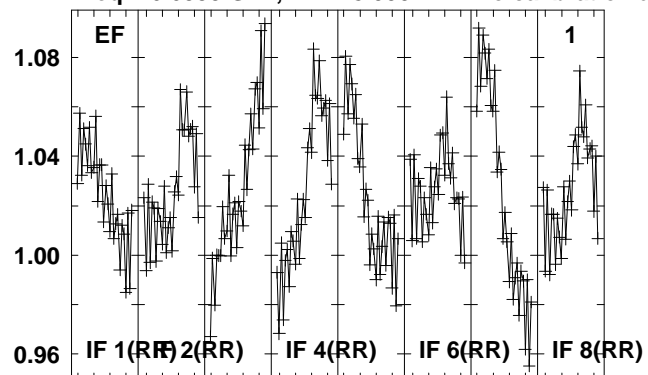

Lower frame: Real Jy

Total-power spectrum Antenna: *

Timerange: 00/16:01:41 to 00/16:03:10

Plot file version 250 created 15-MAR-2012 17:33:26

2102-G85 EZ020E 2.UVDATA.1

Freq = 6.6335 GHz, Bw = 8.000 MH No calibration applied and no bandpass applied

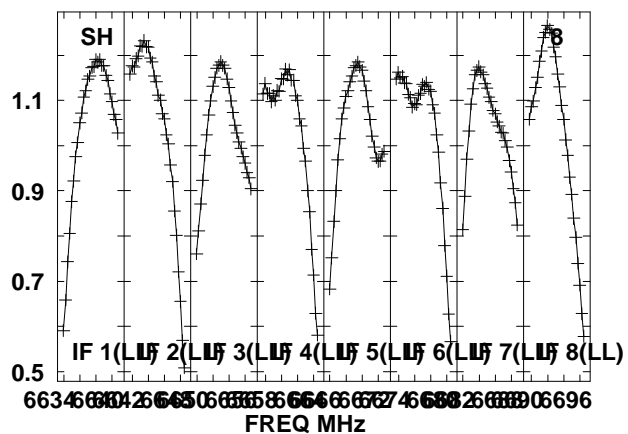
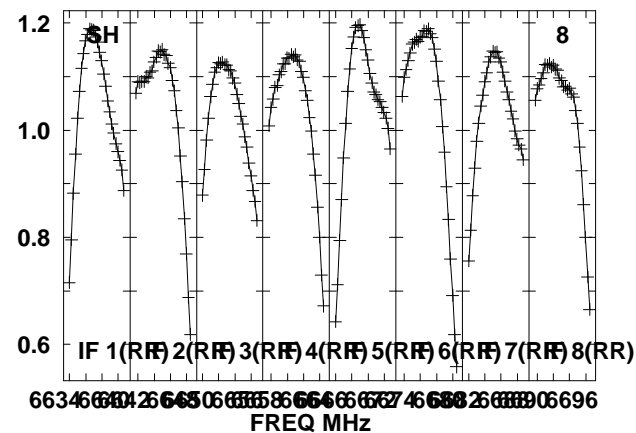
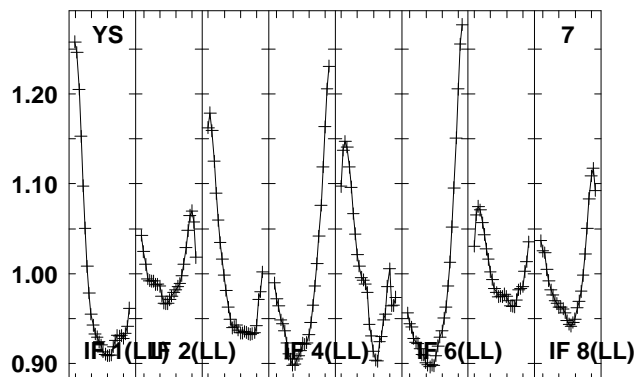
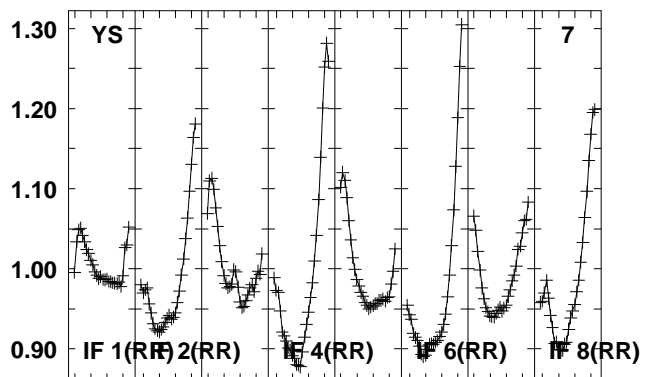
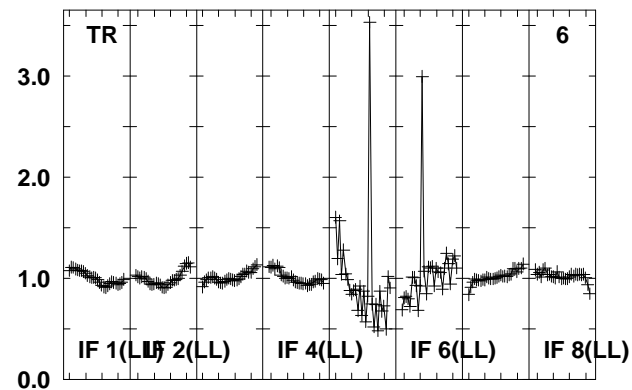
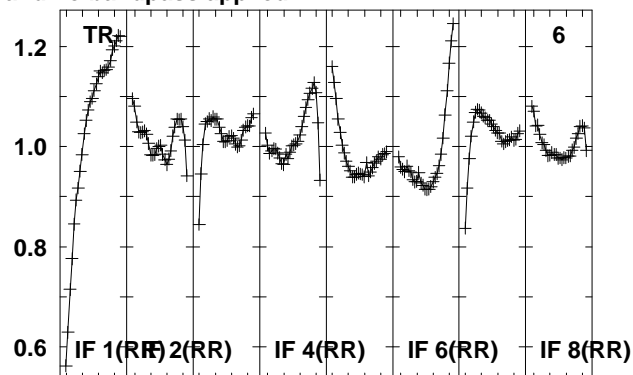
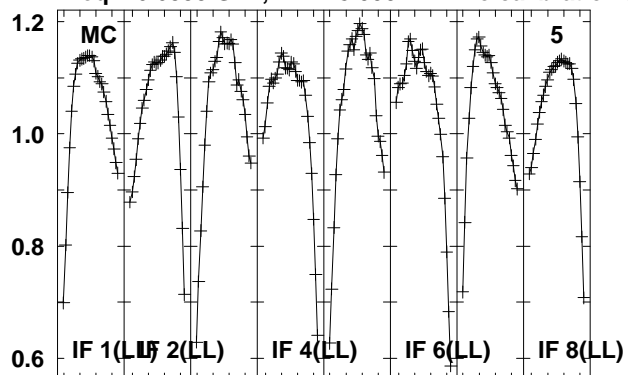

Lower frame: Real Jy

Total-power spectrum Antenna: *

Timerange: 00/16:01:41 to 00/16:03:10

Plot file version 251 created 15-MAR-2012 17:33:28

G85.40 EZ020E 2.UVDATA.1

Freq = 6.6335 GHz, Bw = 8.000 MH No calibration applied and no bandpass applied

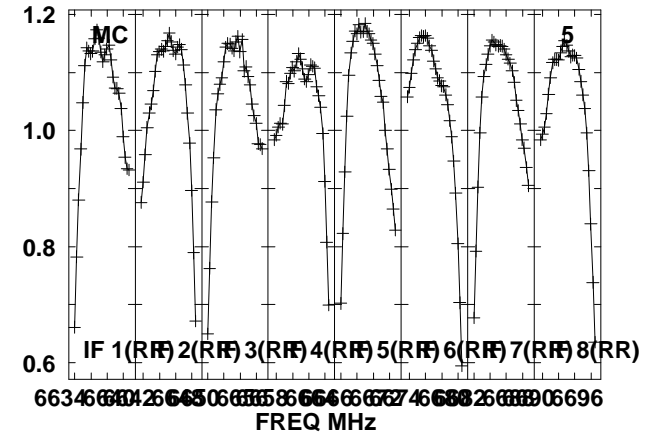
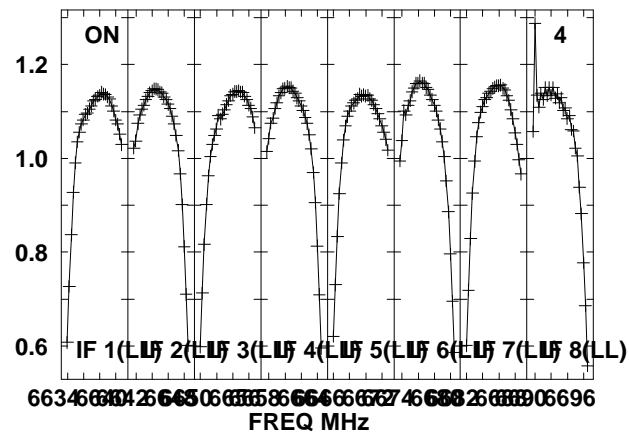
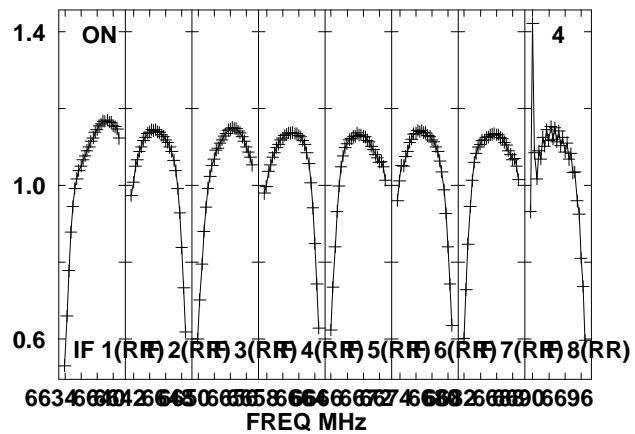
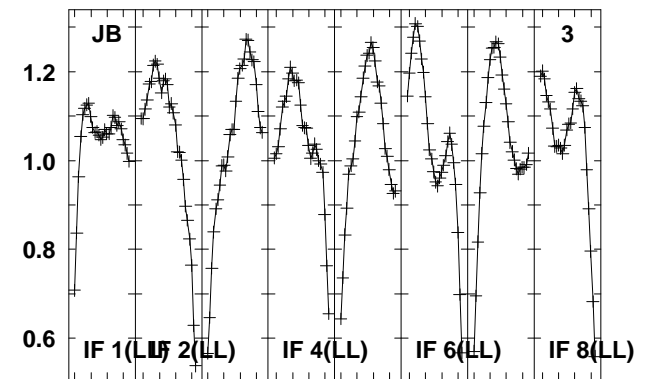
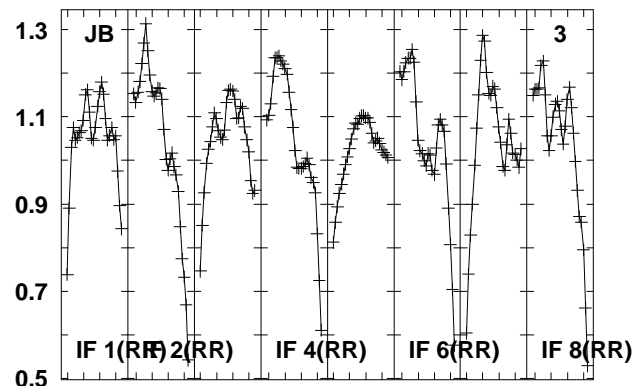
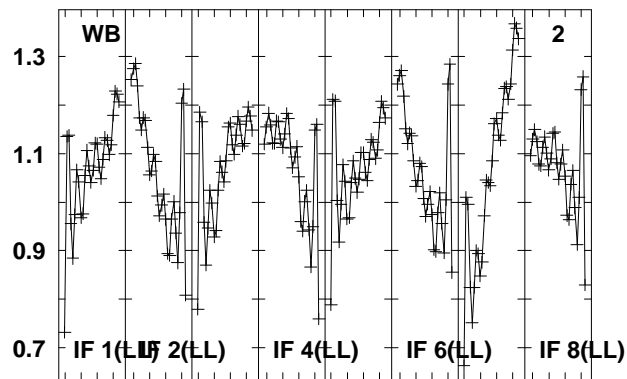
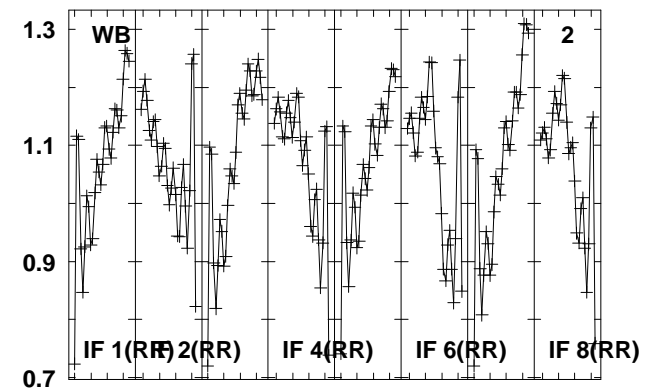
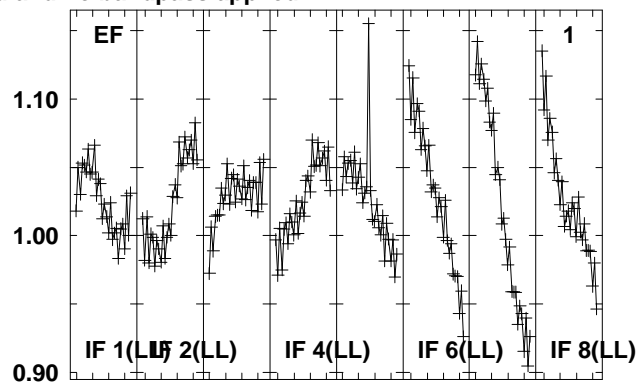
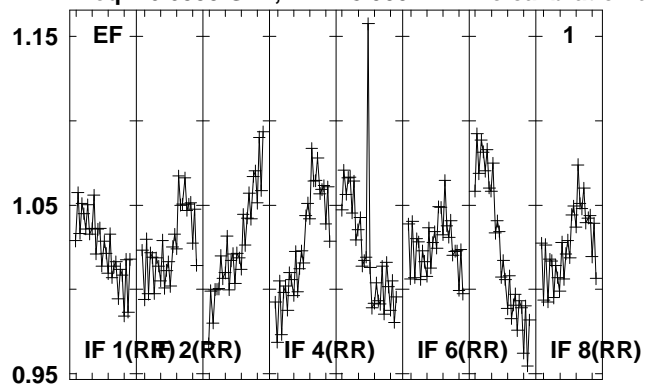

Lower frame: Real Jy
Total-power spectrum Antenna: *
Timerange: 00:16:03:11 to 00:16:04:39

Plot file version 252 created 15-MAR-2012 17:33:28

G85.40 EZ020E 2.UVDATA.1

Freq = 6.6335 GHz, Bw = 8.000 MH No calibration applied and no bandpass applied

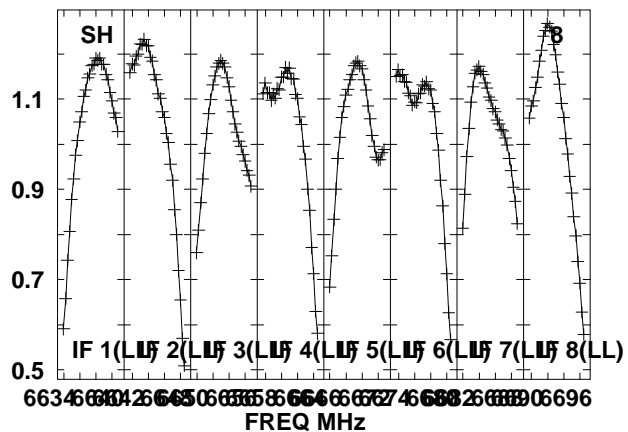
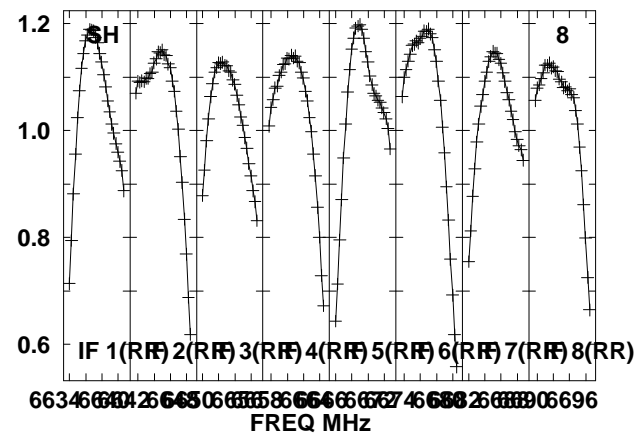
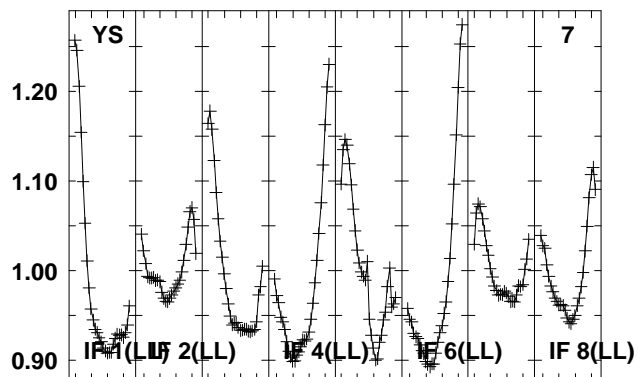
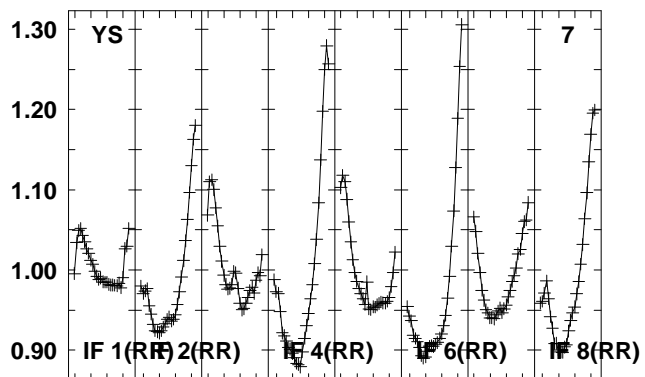
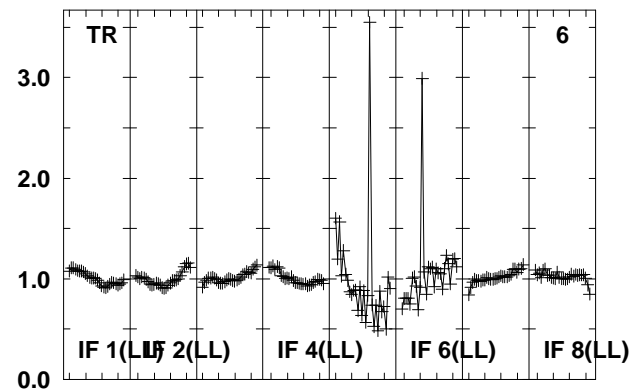
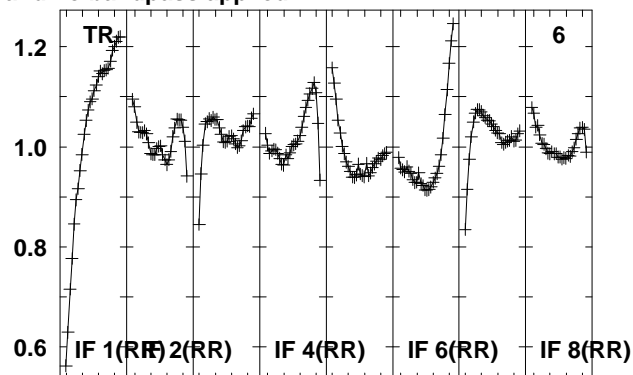
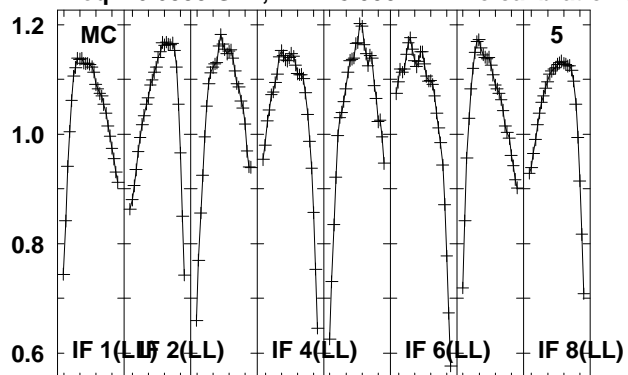

Lower frame: Real Jy

Total-power spectrum Antenna: *

Timerange: 00/16:03:11 to 00/16:04:39

Plot file version 253 created 15-MAR-2012 17:33:29

2114-G85 EZ020E 2.UVDATA.1

Freq = 6.6335 GHz, Bw = 8.000 MH No calibration applied and no bandpass applied

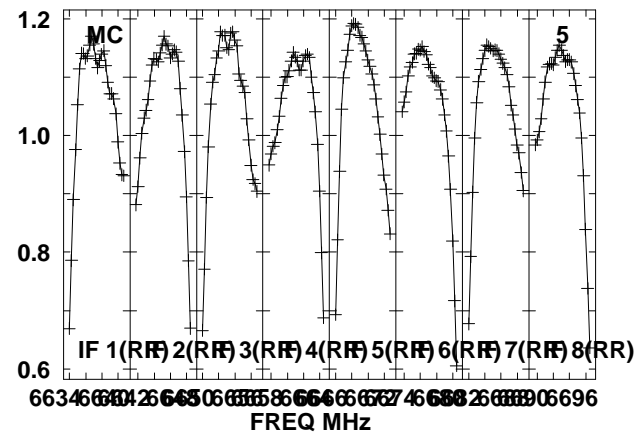
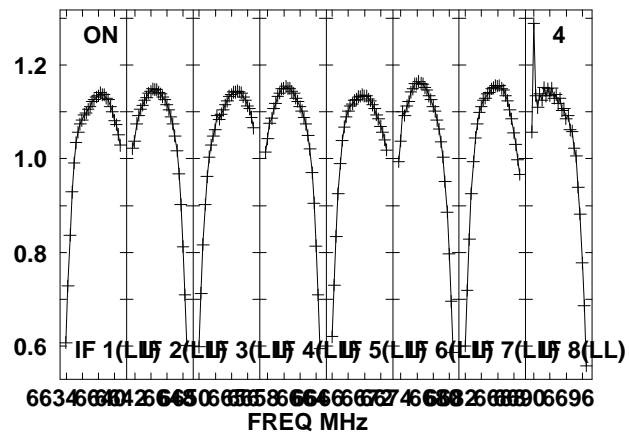
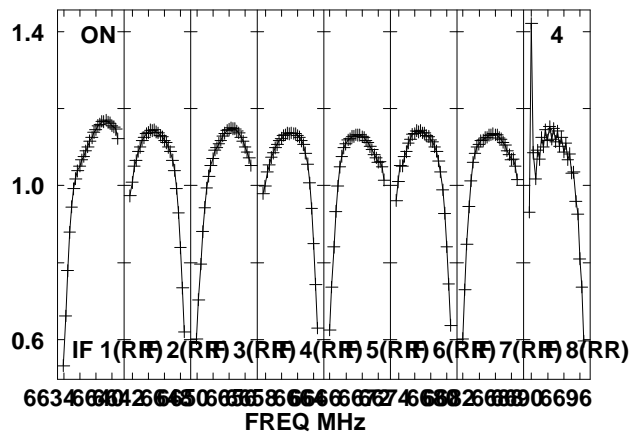
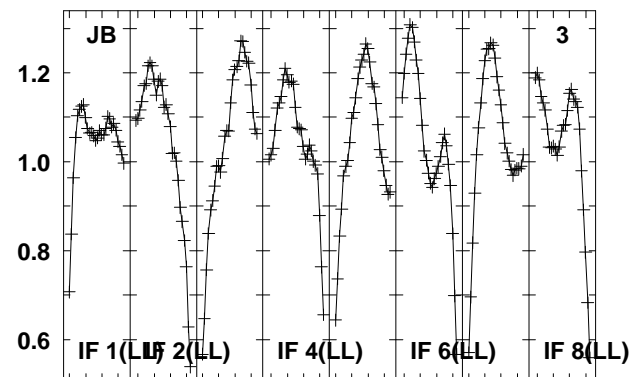
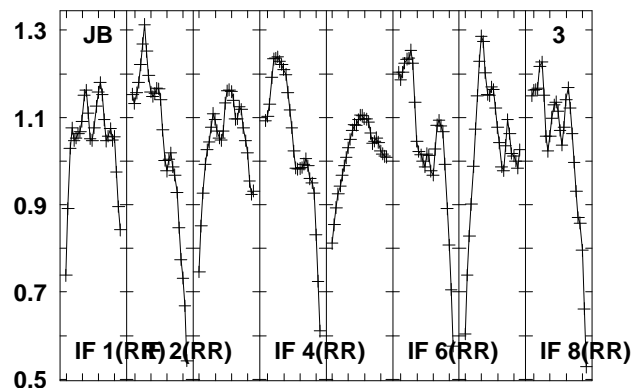
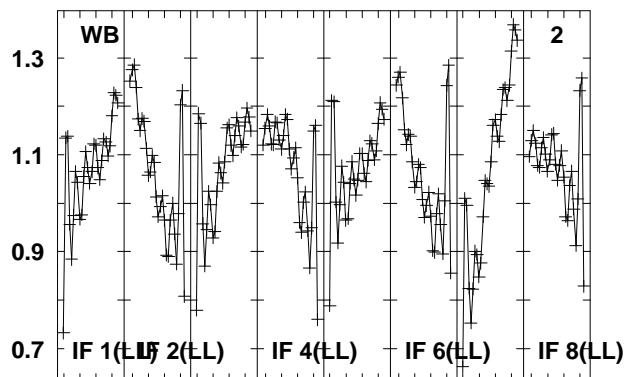
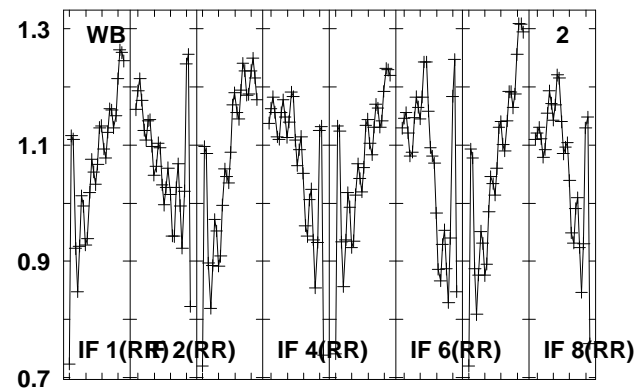
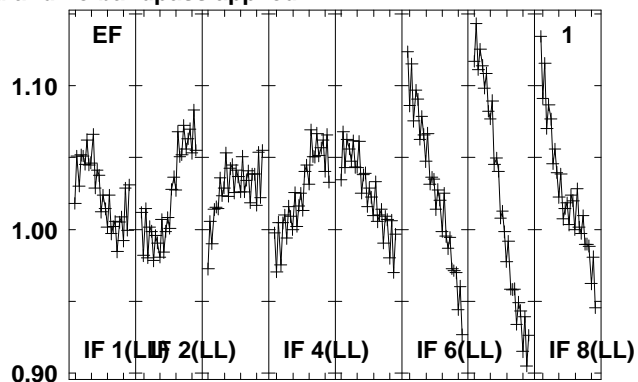
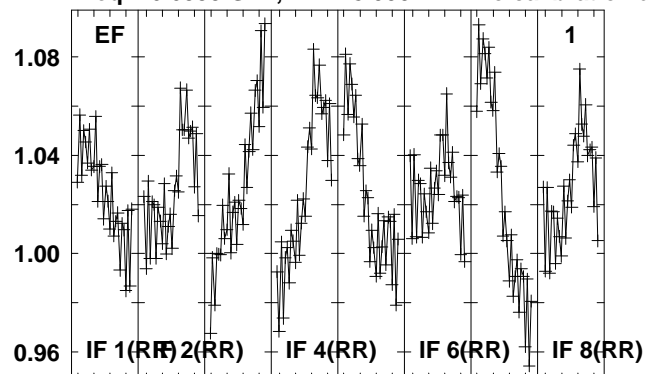

Lower frame: Real Jy

Total-power spectrum Antenna: *

Timerange: 00/16:04:41 to 00/16:06:09

Plot file version 254 created 15-MAR-2012 17:33:30

2114-G85 EZ020E 2.UVDATA.1

Freq = 6.6335 GHz, Bw = 8.000 MH No calibration applied and no bandpass applied

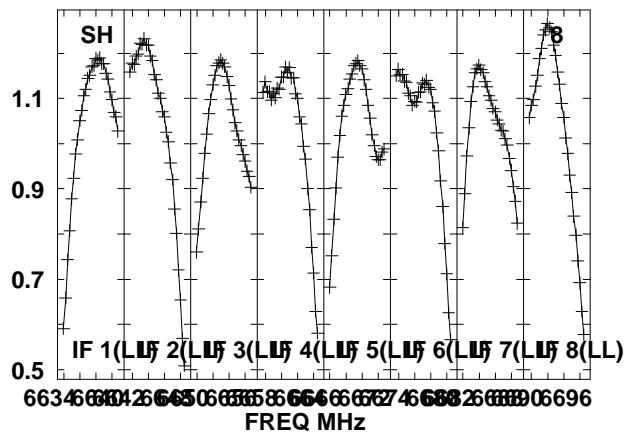
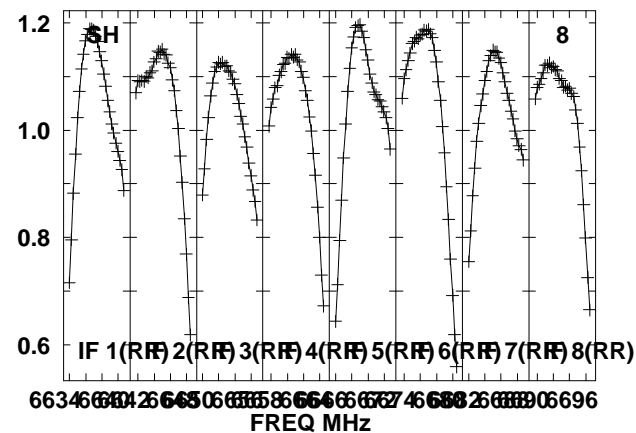
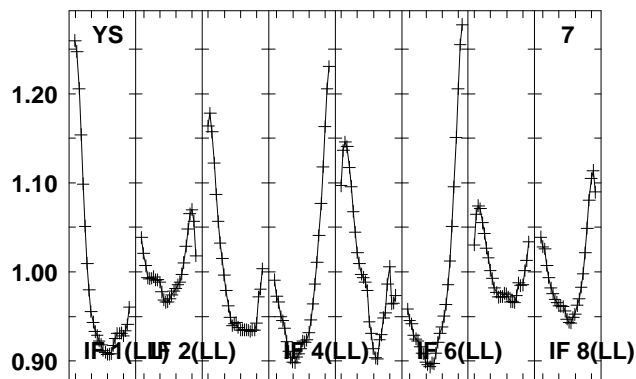
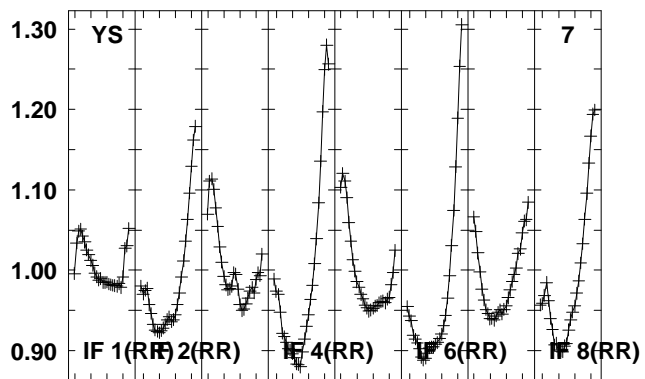
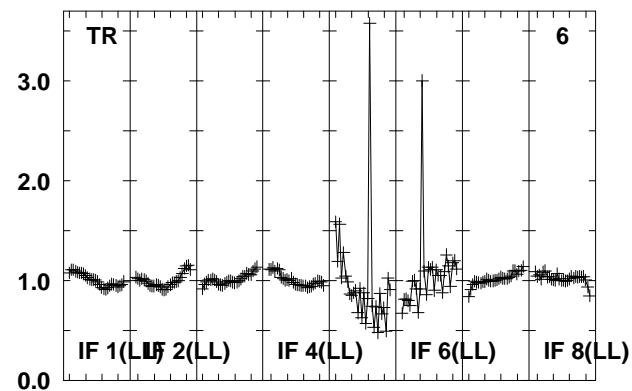
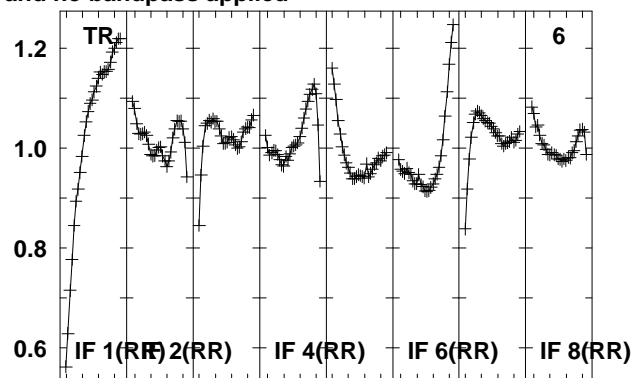
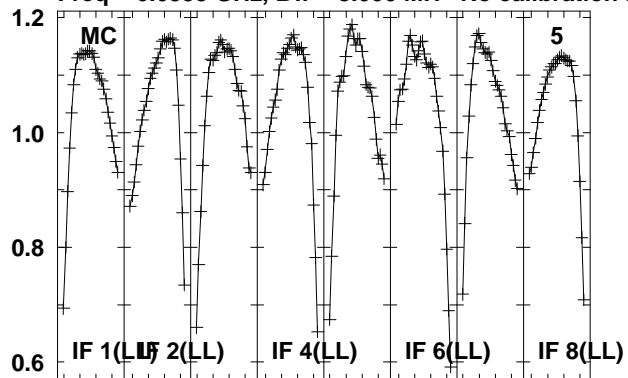

Lower frame: Real Jy

Total-power spectrum Antenna: *

Timerange: 00/16:04:41 to 00/16:06:09

Plot file version 255 created 15-MAR-2012 17:33:31

G85.40 EZ020E 2.UVDATA.1

Freq = 6.6335 GHz, Bw = 8.000 MH No calibration applied and no bandpass applied

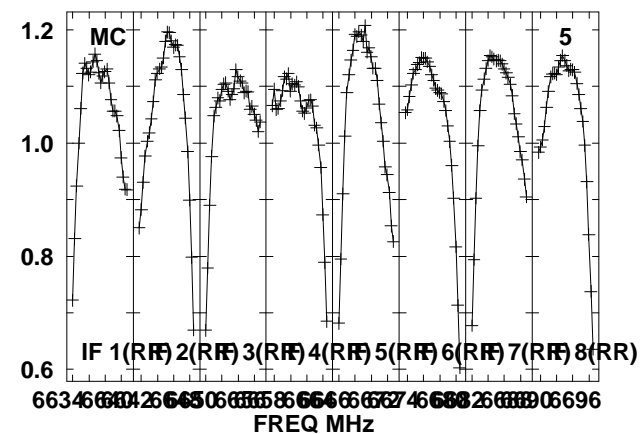
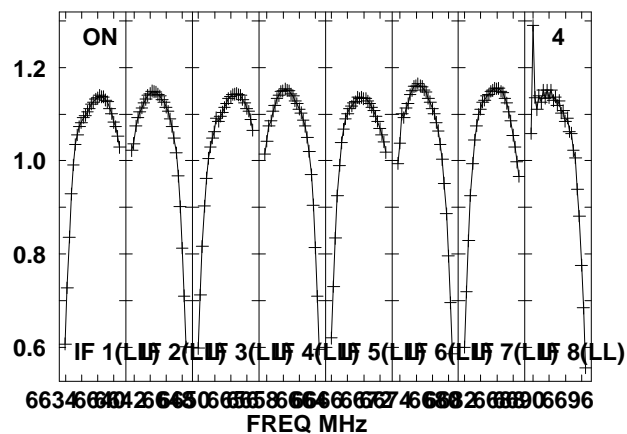
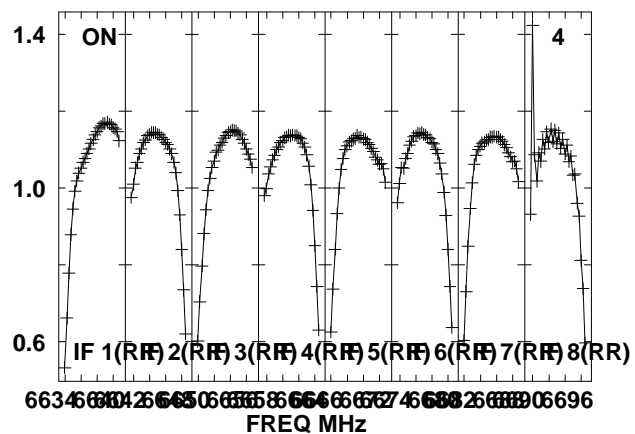
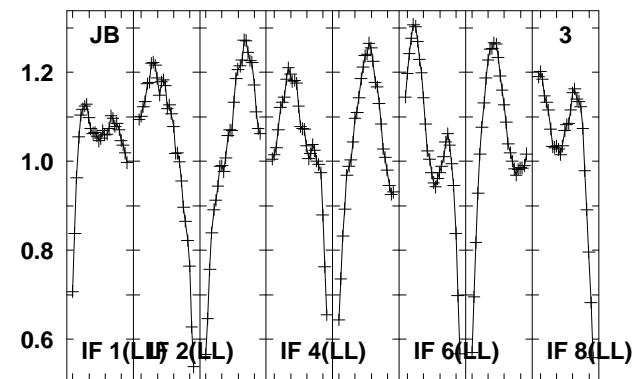
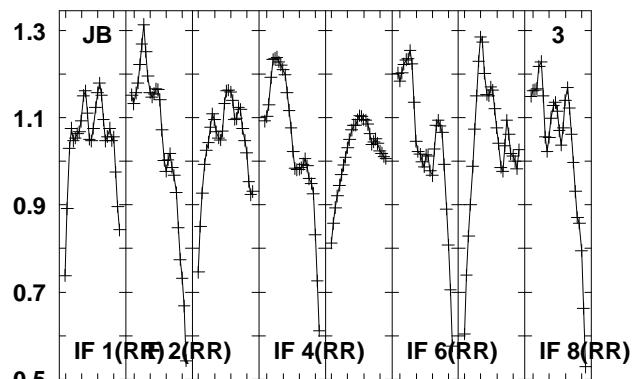
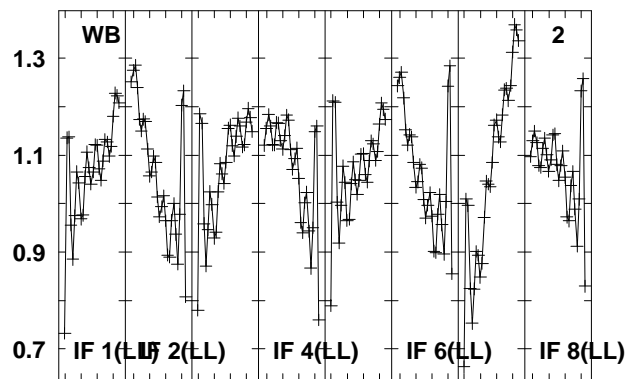
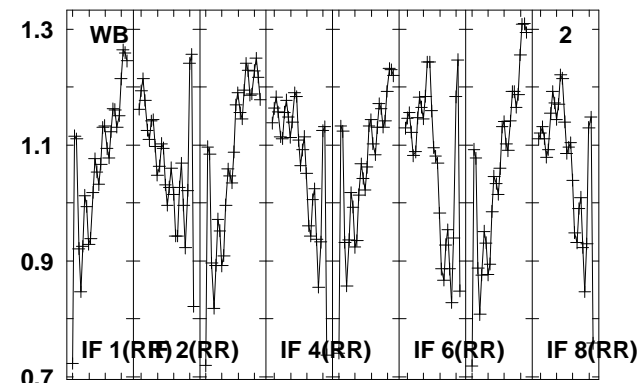
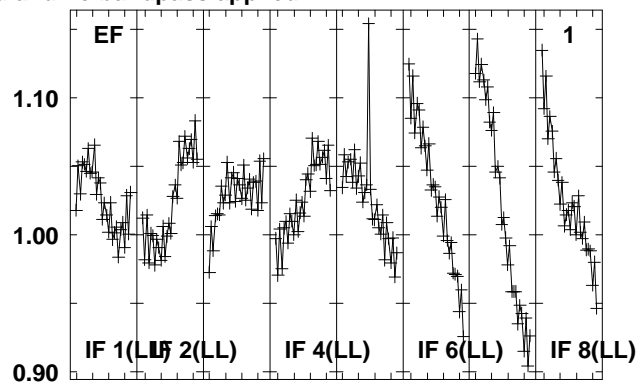
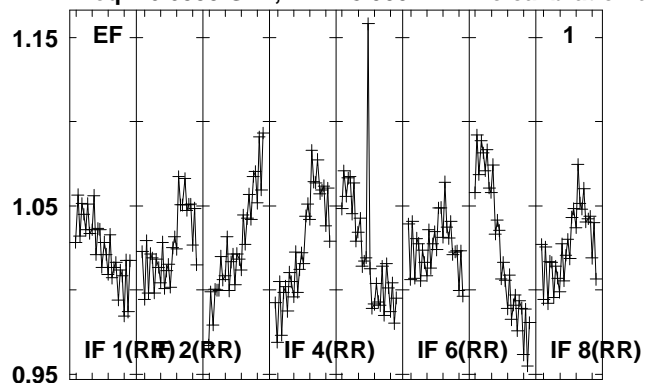

Lower frame: Real Jy
Total-power spectrum Antenna: *
Timerange: 00/16:07:02 to 00/16:08:01

Plot file version 256 created 15-MAR-2012 17:33:31

G85.40 EZ020E 2.UVDATA.1

Freq = 6.6335 GHz, Bw = 8.000 MH No calibration applied and no bandpass applied

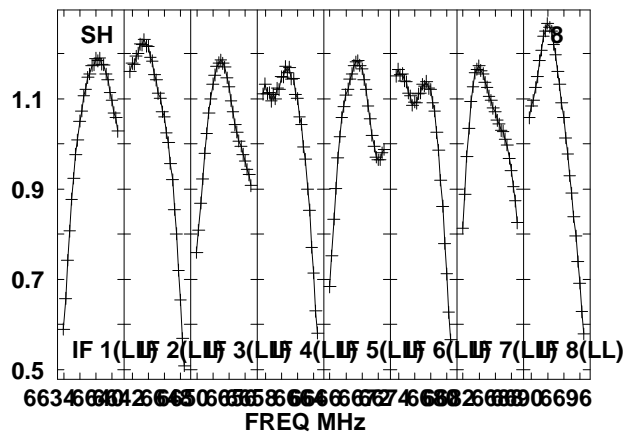
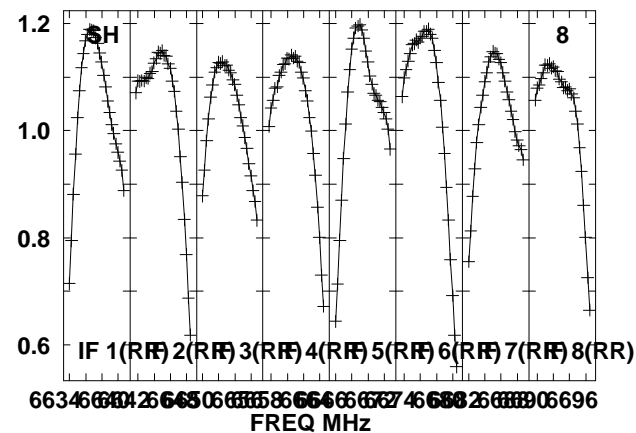
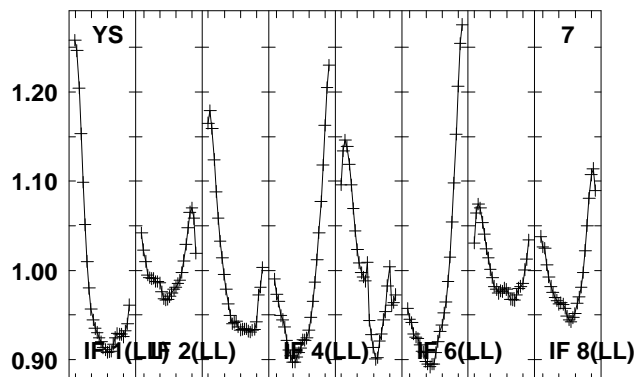
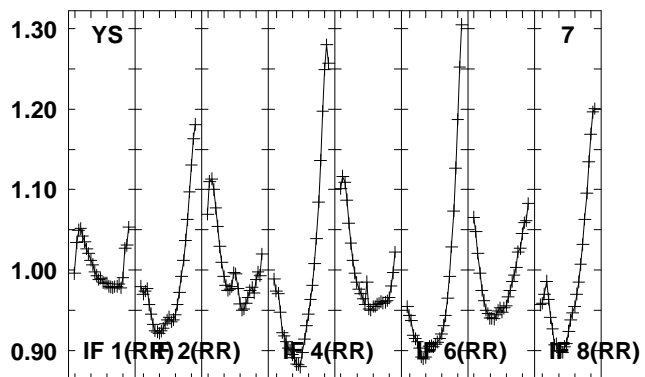
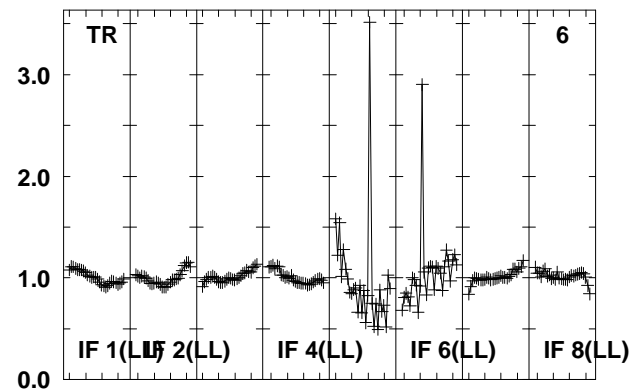
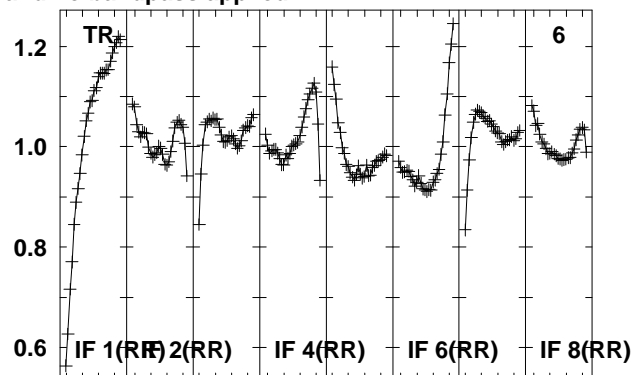
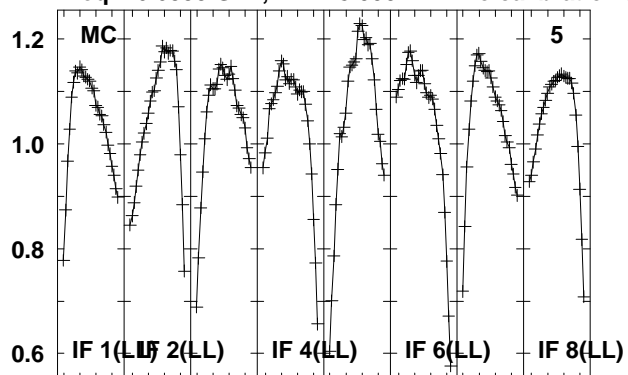

Lower frame: Real Jy

Total-power spectrum Antenna: *

Timerange: 00/16:07:02 to 00/16:08:01

Plot file version 257 created 15-MAR-2012 17:33:32

J1800G85 EZ020E 2.UVDATA.1

Freq = 6.6335 GHz, Bw = 8.000 MH No calibration applied and no bandpass applied

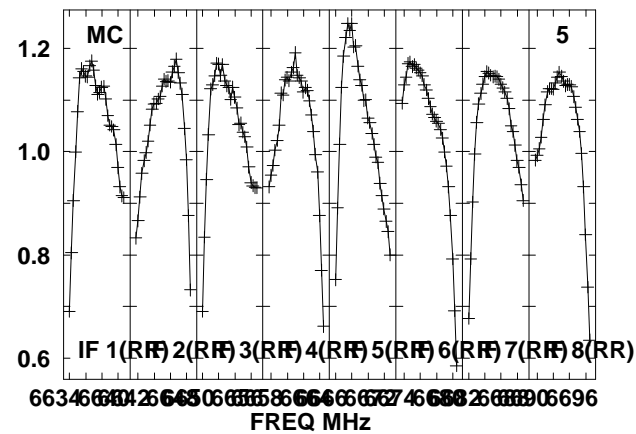
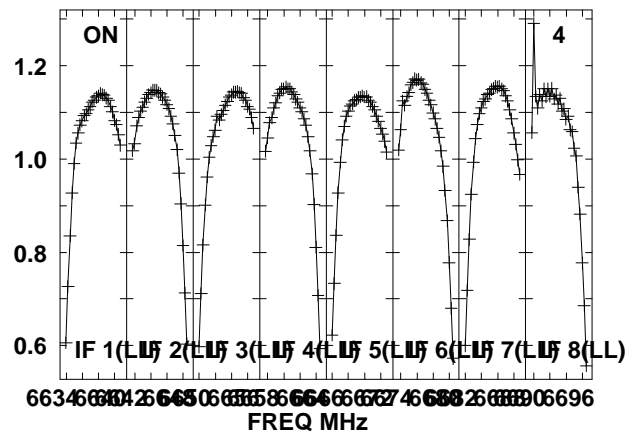
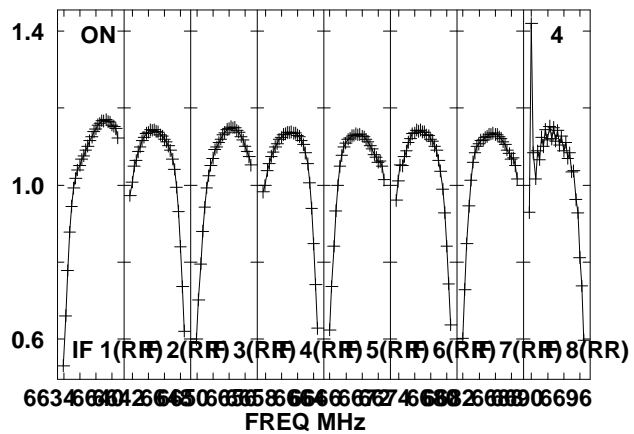
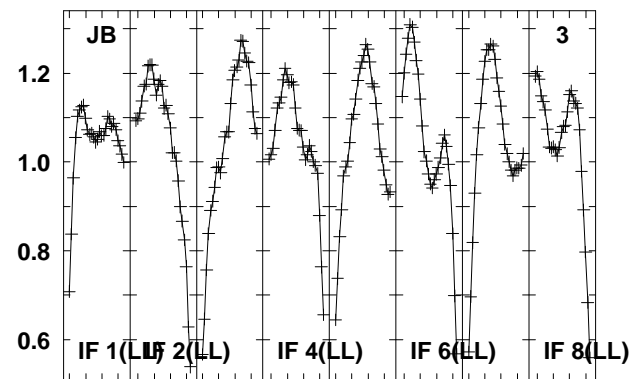
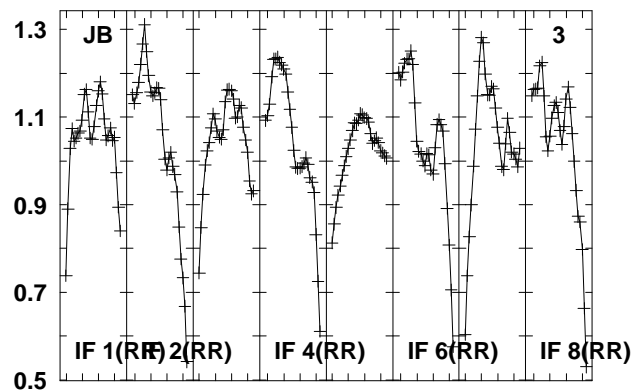
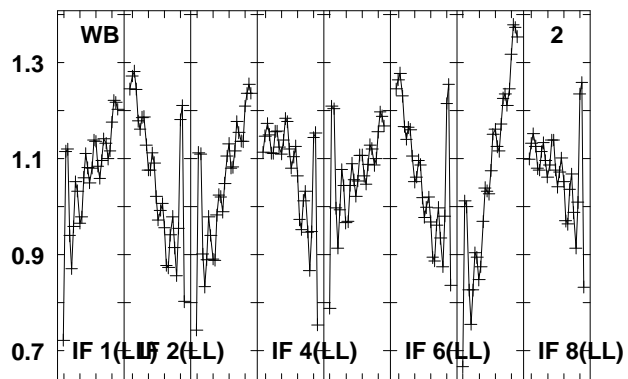
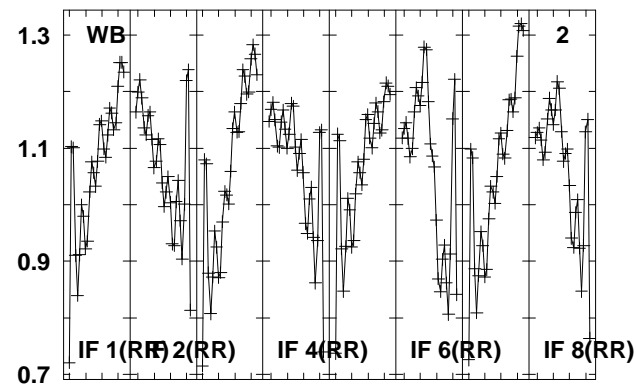
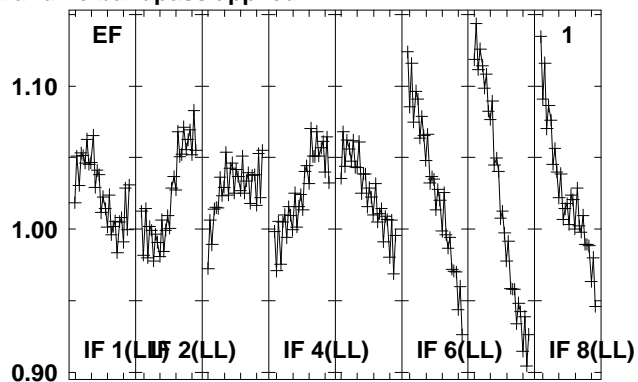
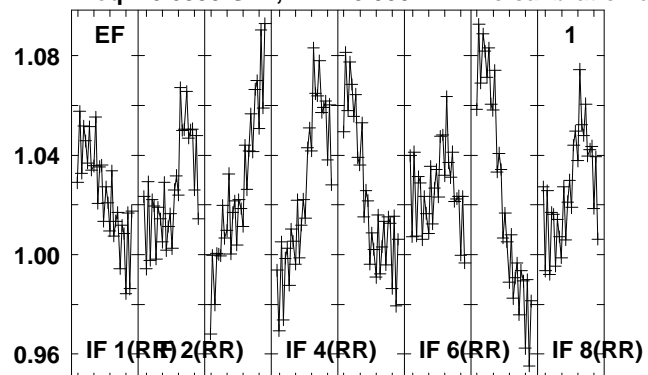

Lower frame: Real Jy
Total-power spectrum Antenna: *
Timerange: 00/16:58:35 to 00/17:01:33

Plot file version 258 created 15-MAR-2012 17:33:33

J1800G85 EZ020E 2.UVDATA.1

Freq = 6.6335 GHz, Bw = 8.000 MH No calibration applied and no bandpass applied

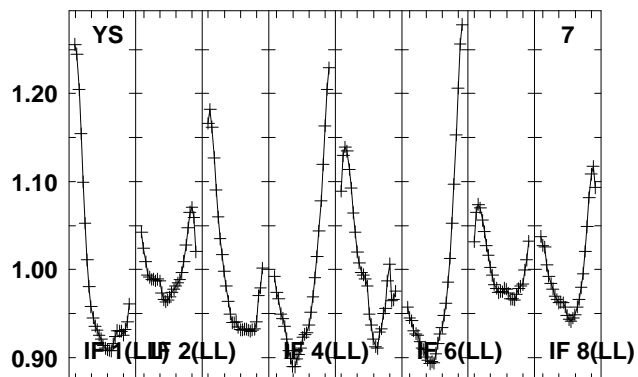
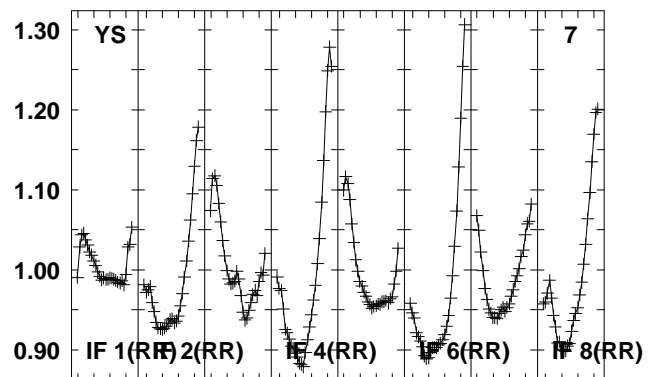
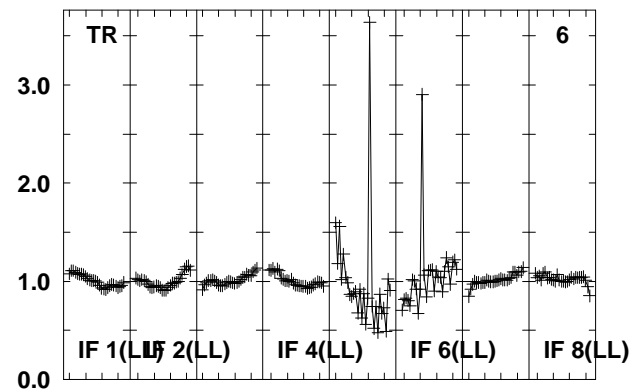
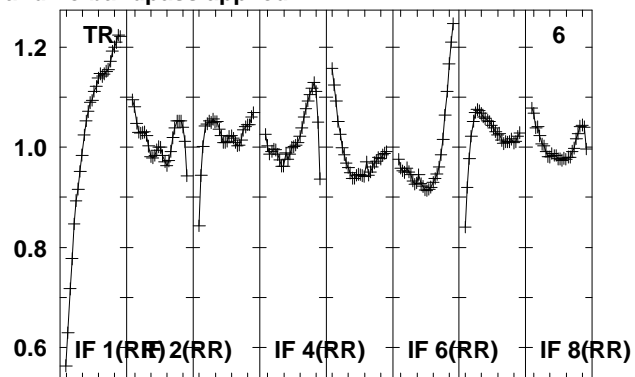
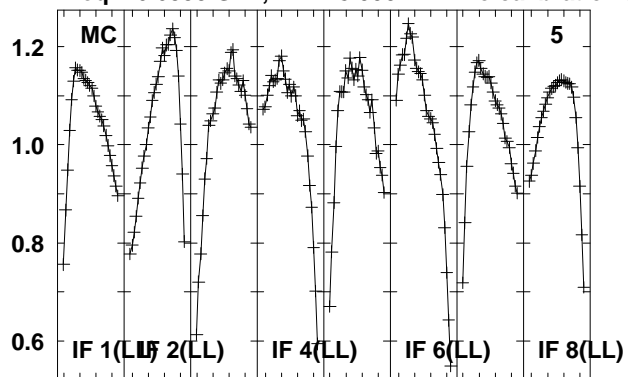

Lower frame: Real Jy
Total-power spectrum Antenna: *
Timerange: 00/16:58:35 to 00/17:01:33